

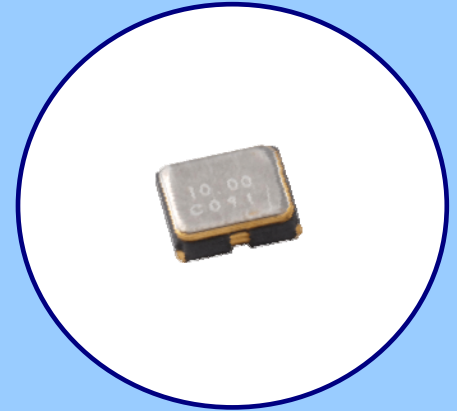

**FEATURES**

- Standard 2.5mm x 2.0mm 4-Pad Surface Mount Package
- HCMOS Output
- Fundamental and 3<sup>rd</sup> Overtone Crystal Designs
- Frequency Range 1 – 110 MHz
- Frequency Stability  $\pm 50$  ppm Standard,  $\pm 25$  ppm and  $\pm 20$  ppm Available
- Operating Voltages +1.8Vdc, +2.5Vdc or +3.3Vdc
- Operating Temperature to -40°C to +85°C
- Output Enable Standard
- Tape & Reel Packaging Standard, EIA-418
- **RoHS/Green Compliant [6/6]**



**APPLICATIONS**

Model 625 is ideal for applications; such as broadband access, Ethernet/Gigabit Ethernet, microprocessors/DSP/FPGA, networking equipment computers and peripherals, digital video, cameras and other portable devices.

**ORDERING INFORMATION**

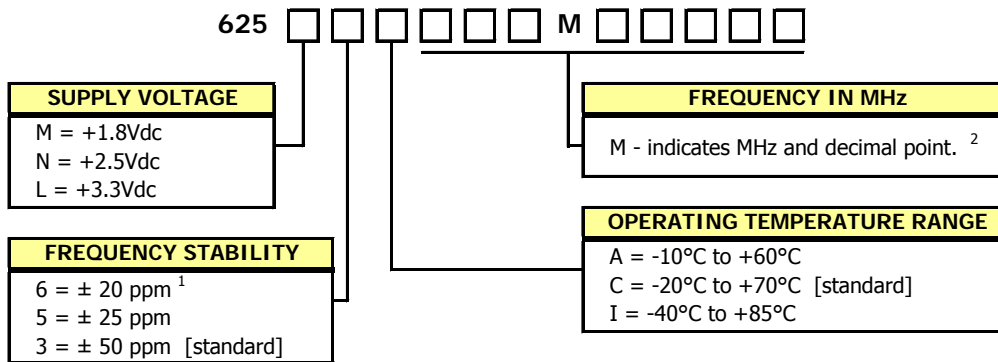

1] Consult factory for 6I Stability/Temperature availability.  
 2] Frequency is recorded with three leading significant digits before the 'M' and 5 significant digits after the 'M' (including zeros).  
 [Ex. 3.579545 MHz, code as 003M57954; 14.31818 MHz, code as 014M31818; 125 MHz, code as 125M00000]

**Not all performance combinations and frequencies may be available.  
 Contact your local CTS Representative or CTS Customer Service for availability.**

**PACKAGING INFORMATION [reference]**

Device quantity is 1k pcs. minimum and 3k pcs. maximum per 180mm reel. **8mm tape width.**

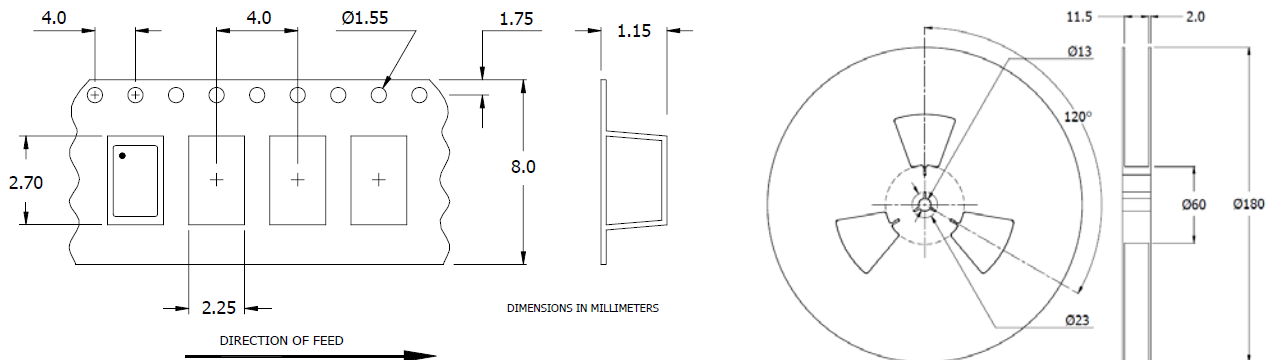

**ELECTRICAL CHARACTERISTICS**

PARAMETER	SYMBOL	CONDITIONS	MIN	TYP	MAX	UNIT
Maximum Supply Voltage	$V_{CC}$	-	-0.5	-	4.0	V
Storage Temperature	$T_{STG}$	-	-40	-	+100	°C
Frequency Range	$f_o$	-	1.0	-	110	MHz
Frequency Stability [See Note 1 and Ordering Information]	$\Delta f/f_o$	-	-	-	20, 25, 50	± ppm
Aging	$\Delta f/f_o$	@+25°C, 1st year	-	-	3	± ppm
Operating Temperature						
Commercial	$T_A$	-	-10	+25	+60	°C
Industrial			-20		+70	
Supply Voltage	$V_{CC}$	±10%	1.62	1.8	1.98	V
Model 625M			2.25		2.75	
Model 625L			2.97		3.63	
Supply Current	$I_{CC}$	$C_L = 15pF$				mA
Model 625M		1.0 MHz to 50 MHz	-	-	7	
[+1.8V]		50.1 MHz to 110 MHz	-	-	15	
Model 625N		1.0 MHz to 50 MHz	-	-	10	
[+2.5V]	50.1 MHz to 110 MHz	-	-	15		
Model 625L	1.0 MHz to 50 MHz	-	-	15		
[+3.3V]	50.1 MHz to 110 MHz	-	-	20		
Output Load	$C_L$		-	-	15	pF
Output Voltage Levels						
Logic '1' Level	$V_{OH}$	CMOS Load	90% $V_{CC}$	-	-	V
Logic '0' Level	$V_{OL}$	CMOS Load	-	-	10% $V_{CC}$	
Output Current						
Logic '1' Level [M,N,L]	$I_{OH}$	$V_{OH} = 90\%V_{CC}$ (1.8V, 2.5, 3.3V)	-	-	-2, -4, -8	mA
Logic '0' Level [M,N,L]	$I_{OL}$	$V_{OL} = 10\%V_{CC}$ (1.8V, 2.5, 3.3V)	-	-	+2, +4, +8	
Output Duty Cycle	SYM	@ 50% Level	45	-	55	%
Rise and Fall Time		@ 10% - 90% Levels, $C_L = 15pF$				
Model 625M	$T_R, T_F$	1.0 MHz to 20 MHz	-	-	5	ns
[+1.8V]		20.1 MHz to 110 MHz	-	-	4	
Model 625N		1.0 MHz to 20 MHz	-	-	4	
[+2.5V]		20.1 MHz to 110 MHz	-	-	3	
Model 625L	1.0 MHz to 20 MHz	-	-	3		
[+3.3V]	20.1 MHz to 110 MHz	-	-	2		
Start Up Time	$T_S$	Application of $V_{CC}$	-	2	5	ms
Enable Function						
Enable Input Voltage	$V_{IH}$	Pin 1 Logic '1', Output Enabled	0.7* $V_{CC}$	-	-	V
Disable Input Voltage	$V_{IL}$	Pin 1 Logic '0', Output Disabled	-	-	0.3* $V_{CC}$	
Enable Time [M,N,L]	$T_{PLZ}$	Pin 1 Logic '1'	-	-	5	ms
Standby Current	$I_{ST}$	Pin 1 Logic '0', Output Disabled	-	-	15	µA
Period Jitter, pk-pk	pjpk-pk	-	-	-	40	ps
Period Jitter, RMS	pjrms	-	-	-	25	
Phase Jitter, RMS	tjrms	Bandwidth 12 kHz - 20 MHz	-	-	1	

Notes:

- Inclusive of initial tolerance at time of shipment, changes in supply voltage, load, temperature and aging.

**LVC MOS OUTPUT WAVEFORM**

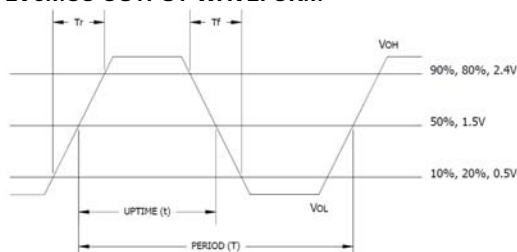

**TEST CIRCUIT, CMOS LOAD**

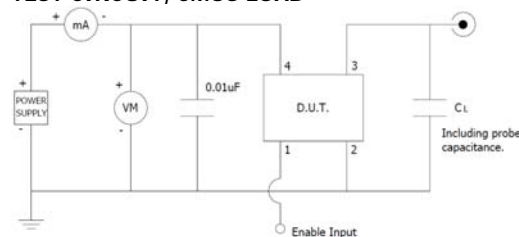

**ENABLE TRUTH TABLE**

PIN 1	PIN 3
Logic '1'	Output
Open	Output
Logic '0'	High Imp.

**MECHANICAL SPECIFICATIONS**

**PACKAGE DRAWING**

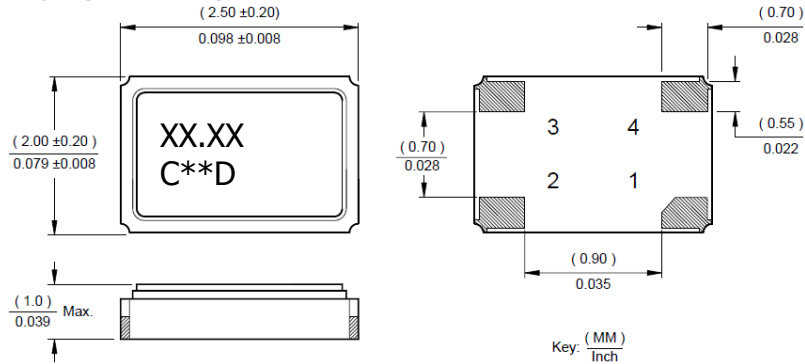

**MARKING INFORMATION**

1. XX.XX – Frequency in MHz.
2. C – CTS and Pin 1 identifier.
3. \*\* - Manufacturing Site Code.
4. D – Manufacturing Date Code.  
[See Table 1 for codes.]
5. Complete CTS part number, frequency value and date code information must appear on reel and carton labels.

**NOTES**

1. Termination pads [e4]. Barrier-plating is nickel [Ni] with gold [Au] flash plate.
2. Reflow conditions per JEDEC J-STD-020; 260°C maximum, 20 seconds.
3. MSL = 1.

**TABLE I**

YEAR \ MONTH					JAN	FEB	MAR	APR	MAY	JUN	JUL	AUG	SEP	OCT	NOV	DEC
					A	B	C	D	E	F	G	H	J	K	L	M
2001	2005	2009	2013	2017	A	B	C	D	E	F	G	H	J	K	L	M
2002	2006	2010	2014	2018	N	P	Q	R	S	T	U	V	W	X	Y	Z
2003	2007	2011	2015	2019	a	b	c	d	e	f	g	h	j	k	l	m
2004	2008	2012	2016	2020	n	p	q	r	s	t	u	v	w	x	y	z

**SUGGESTED SOLDER PAD GEOMETRY**

C<sub>BYPASS</sub> should be ≥ 0.01 uF.

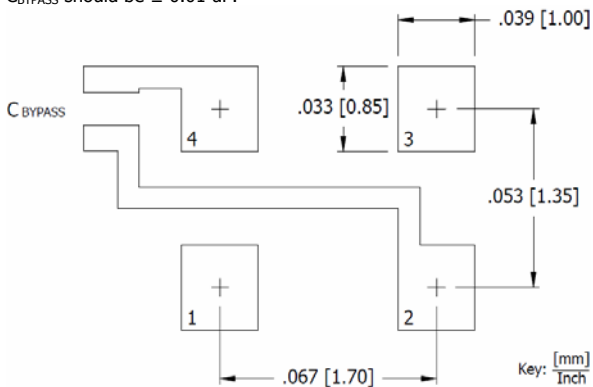

**D.U.T. PIN ASSIGNMENTS**

PIN	SYMBOL	DESCRIPTION
1	EOH	Enable
2	GND	Circuit & Package Ground
3	Output	RF Output
4	V <sub>CC</sub>	Supply Voltage

## X-ON Electronics

Largest Supplier of Electrical and Electronic Components

*Click to view similar products for [Standard Clock Oscillators](#) category:*

*Click to view products by [CTS](#) manufacturer:*

Other Similar products are found below :

[601252](#) [F335-25](#) [F535L-33.333](#) [F535L-50](#) [NBXHBA019LN1TAG](#) [SiT1602BI-22-33E-50.000000E](#) [SIT8918AA-11-33S-50.000000G](#)  
[SM4420TEV-40.0M-T1K](#) [F335-24](#) [F335-40](#) [F535L-10](#) [F535L-12](#) [F535L-24](#) [F535L-27](#) [PE7744DW-100.0M](#) [ASF1-3.686MHZ-N-K-S](#) [ASV-](#)  
[4.000MHZ-LCS-T](#) [XLH735025.000JU4I8](#) [XLP725125.000JU6I8](#) [XO57CTECNA3M6864](#) [601251](#) [SiT8503AI-18-33E-0.200000X](#)  
[SIT8918AA-11-33S-16.000000G](#) [SIT9122AI2C233E300.000000X](#) [9120AC-2D2-33E212.500000](#) [9102AI-243N25E100.000000](#) [8208AC-82-](#)  
[18E-25.000000](#) [8008AI-72-XXE-24.545454E](#) [8004AC-13-33E-133.330000X](#) [AS-4.9152-16-SMD-TR](#) [ASFL1-48.000MHZ-LC-T](#)  
[632L3I004M000000](#) [SIT8920AM-31-33E-25.0000](#) [DSC1028DI2-019.2000](#) [9121AC-2C3-25E100.000000](#) [9102AI-233N33E100.000000X](#)  
[9102AI-233N25E200.000000](#) [9102AI-232H25S125.000000](#) [9102AI-133N25E200.000000](#) [9102AC-283N25E200.000000](#) [9001AC-33-33E1-30.000](#)  
[8103AC-13-33E-12.000000X](#) [3921AI-2CF-33NZ125.000000](#) [5730-1SF](#) [XUN736000.032768I](#) [ASV-25.000MHZ-ECS-50-T](#) [EC3925ETTTS-](#)  
[100.000M TR](#) [SIT1602BC-83-33E-10.000000Y](#) [8003AI-12-33S-40.000000Y](#) [1602BI-13-33S-19.200000E](#)