

Model CA32

AUTOMOTIVE GRADE HCMOS CLOCK

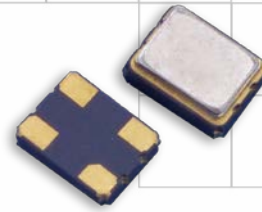

Part Dimensions:
3.2 x 2.5 x 1.2mm • 30.803mg

Features

- AEC-Q200 Compliant
- Ceramic Surface Mount Package
- Operating Temperature Range to -55°C to +105°C
- Fundamental and 3rd Overtone Crystal Designs
- Frequency Range 1.25 – 156.25MHz
- +1.8V, +2.5V and +3.3V Operation
- Output Enable Standard
- Tape and Reel Packaging, EIA-418

Standard Frequencies

* See Page 6 for common frequencies.
Check with factory for availability of frequencies not listed.

Applications

- Automotive Electronics
- Mobile Multimedia/Infotainment
- Audio/Video Systems
- Wireless Communication
- Medical Electronics
- Commercial Military & Aerospace

Description

CTS Model CA32 is a low cost, small size, Clock Oscillator [XO] developed for use in automotive electronics operating over extended temperature ranges. CA32 has an HCMOS/TTL compatible output, offers excellent stability and low jitter/phase noise performance.

Ordering Information

Model	Output Type	Frequency Code [MHz]	Frequency Stability	Temperature Range	Supply Voltage	Packaging
CA 32	C	XXX or XXXX	3	G	3	T
Code Package Size		Code Frequency		Code Temp. Range		Code Packing
32 3.2x2.5mm		Product Frequency Code ¹		I -40°C to +85°C ²		T 1k pcs./reel
				G -40°C to +105°C ³		
				H -40°C to +125°C ⁴		
				N -40°C to +150°C ⁵		
				P -55°C to +105°C ⁵		
	Code Output		Code Stability		Code Voltage	
	C HCMOS		5 ±25ppm		M +1.8Vdc	
			4 ±30ppm		N +2.5Vdc	
			3 ±50ppm		L +3.3Vdc	
			2 ±100ppm			
			7 ±150ppm			

Notes:

- 1] Refer to document 016-1454-0, Frequency Code Tables. 3-digits for frequencies <100MHz, 4-digits for frequencies 100MHz or greater.
- 2] Available with all stability codes.
- 3] Available with stability codes 4, 3, 2 and 7.
- 4] Available with stability codes 3, 2 and 7.
- 5] Stability codes 2 and 7. Contact factory for availability.

**Not all performance combinations and frequencies may be available.
Contact your local CTS Representative or CTS Customer Service for availability.**

This product is specified for use only in standard commercial applications. Supplier disclaims all express and implied warranties and liability in connection with any use of this product in any non-commercial applications or in any application that may expose the product to conditions that are outside of the tolerances provided in its specification.



Electrical Specifications

Operating Conditions

PARAMETER	SYMBOL	CONDITIONS	MIN	TYP	MAX	UNIT
Maximum Supply Voltage	V_{CC}	-	-0.5	-	4.0	V
Supply Voltage	V_{CC}	±5%	1.710	1.8	1.890	V
			2.375	2.5	2.665	
			3.135	3.3	3.465	
Typical @ Nominal V_{CC} , $C_L = 15$ pF, $T_A = +25^\circ\text{C}$						
Supply Current	I_{CC}	@ +1.8V	-	15	40	mA
		@ +2.5V	-	20	40	
		@ +3.3V	-	20	40	
Output Load	C_L	-	-	-	15	pF
Operating Temperature	T_A	-	-40	-	+85	°C
			-40	-	+105	
			-40	+25	+125	
			-40	-	+150	
			-55	-	+105	
Storage Temperature	T_{STG}	-	-55	-	+125	°C

Frequency Stability

PARAMETER	SYMBOL	CONDITIONS	MIN	TYP	MAX	UNIT
Frequency Range	f_O	-		1.25 - 156.25		MHz
Frequency Stability [Note 1]	$\Delta f/f_O$	-		25, 30, 50, 100 or 150		±ppm
Aging	$\Delta f/f_{25}$	First Year @ +25°C, nominal V_{CC}	-5	-	5	ppm

1.] Inclusive of initial tolerance at time of shipment, changes in supply voltage, load, temperature and 1st year aging.

Output Parameters

PARAMETER	SYMBOL	CONDITIONS	MIN	TYP	MAX	UNIT
Output Type	-	-		HCMOS		-
Output Voltage Levels	V_{OH}	Logic '1' Level, CMOS Load	$0.9V_{CC}$	-	-	V
	V_{OL}	Logic '0' Level, CMOS Load	-	-	$0.1V_{CC}$	
Output Current Levels	I_{OH}	$V_{OH} = 90\%V_{CC}$ [1.8V, 2.5V, 3.3V]	-	-	-4, -4, -8	mA
	I_{OL}	$V_{OL} = 10\%V_{CC}$ [1.8V, 2.5V, 3.3V]	-	-	+4, +4, +8	
Output Duty Cycle	SYM	@ 50% Level	45	-	55	%
@ 10%/90% Levels, Nominal V_{CC} , $C_L = 15$ pF						
Rise and Fall Time [Note 2]	T_R, T_F	@ +1.8V	-	5	7	ns
		@ +2.5V	-	5	7	
		@ +3.3V	-	5	7	
Start Up Time	T_S	Application of V_{CC}	-	2	5	ms

2.] Parameters are worst case and account for comprehensive range of product specification. Performance may vary by application and must be validated by end user.

Electrical Specifications

Output Parameters

PARAMETER	SYMBOL	CONDITIONS	MIN	TYP	MAX	UNIT
Enable Function		Standby				
Enable Input Voltage	V_{IH}	Pin 1 Logic '1', Output Enabled	$0.7V_{CC}$	-	-	V
Disable Input Voltage	V_{IL}	Pin 1 Logic '0', Output Standby	-	-	$0.3V_{CC}$	V
Enable Current	I_{STB}	Pin 1 Logic '0', Output Standby	-	-	10	μA
Enable Time	T_{PLZ}	Pin 1 Logic '1'	-	-	5	ms
Phase Jitter, RMS	t_{jrms}	Bandwidth 12 kHz - 20 MHz	-	0.5	<1	ps

Enable Truth Table

Pin 1	Pin 3
Logic '1'	Output
Open	Output
Logic '0'	High Imp.

Test Circuit

HCMOS

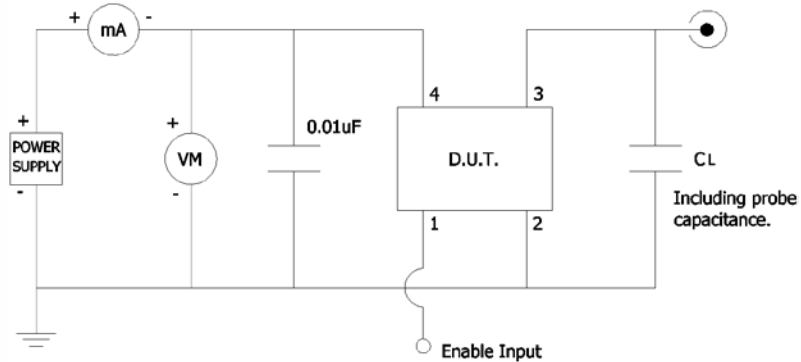

Output Waveform

HCMOS

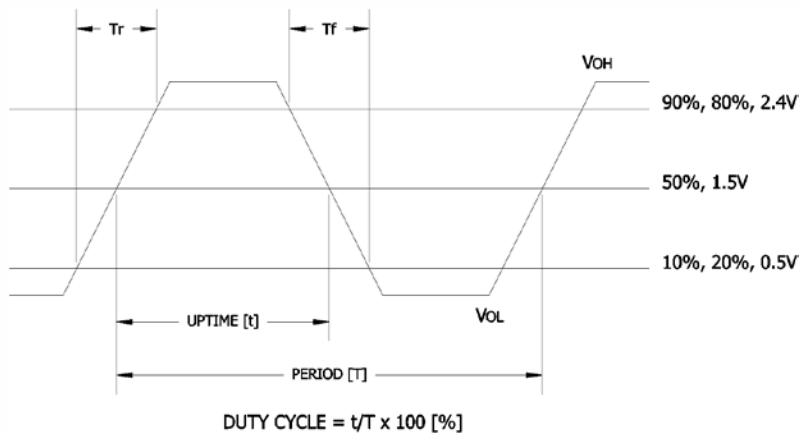

Mechanical Specifications

Package Drawing

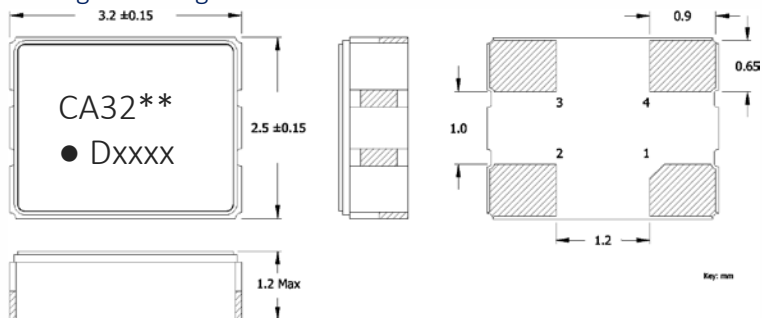

Marking Information

1. CA32 – CTS model.
 2. ** – Manufacturing Site Code.
 3. ● – Pin 1 identifier.
 4. D – Date Code. See Table I for codes.
 5. xxxx – Frequency Code.
3-digits for frequencies <100MHz
4-digits for frequencies 100MHz or greater
- [See document 016-1454-0, Frequency Code Tables.]

Recommended Pad Layout

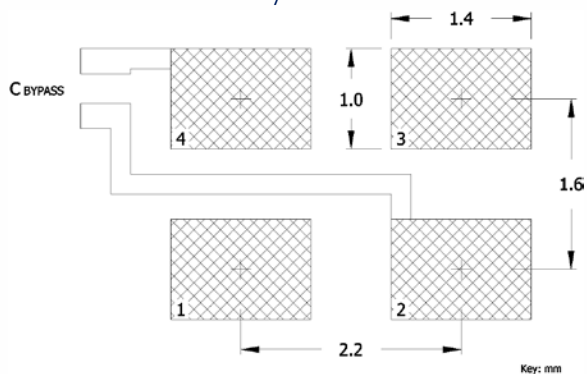

Notes

1. Termination pads (e4). Barrier-plating is nickel [Ni] with gold [Au] flash plate.
2. Reflow conditions per JEDEC J-STD-020; +260°C maximum, 20 seconds.
3. MSL = 1.

Pin Assignments

Pin	Symbol	Function
1	EOH	Enable
2	GND	Circuit & Package
3	Output	RF Output
4	V _{CC}	Supply Voltage

Table I - Date Code

		MONTH					YEAR														
		JAN	FEB	MAR	APR	MAY	JUN	JUL	AUG	SEP	OCT	NOV	DEC								
2001	2005	2009	2013	2017	A	B	C	D	E	F	G	H	J	K	L	M					
2002	2006	2010	2014	2018	N	P	Q	R	S	T	U	V	W	X	Y	Z					
2003	2007	2011	2015	2019	a	b	c	d	e	f	g	h	j	k	l	m					
2004	2008	2012	2016	2020	n	p	q	r	s	t	u	v	w	x	y	z					



Addendum

Common Frequencies Available – MHz

FREQUENCY	FREQUENCY CODE	FREQUENCY	FREQUENCY CODE	FREQUENCY	FREQUENCY CODE	FREQUENCY	FREQUENCY CODE
4.000000	040	24.000000	240	40.000000	400		
8.000000	080	24.576000	24C	48.000000	480		
10.000000	100	25.000000	250	50.000000	500		
12.000000	120	26.000000	260	100.000000	1000		
12.288000	122	27.000000	270	125.000000	1250		
14.318180	143	30.000000	300	156.250000	1562		
14.745600	147	32.000000	320				
16.000000	160	33.333000	33E				
20.000000	200	37.400000	374				
22.118400	221	38.400000	384				

X-ON Electronics

Largest Supplier of Electrical and Electronic Components

Click to view similar products for [Standard Clock Oscillators](#) category:

Click to view products by [CTS](#) manufacturer:

Other Similar products are found below :

[EP1400SJTSC-125.000M](#) [601137](#) [601252](#) [CSX750FBC-24.000M-UT](#) [CSX750FBC-33.333M-UT](#) [CSX750FCC-3.6864M-UT](#) [F335-12](#) [F335-25](#) [DSC506-03FM2](#) [ASA-20.000MHZ-L-T](#) [ASA-25.000MHZ-L-T](#) [ASA-27.000MHZ-L-T](#) [ASV-20.000MHZ-LR-T](#) [ECS-2018-160-BN-TR](#) [EL13C7-H2F-125.00M](#) [MXO45HS-2C-66.6666MHZ](#) [SiT1602BI-22-33E-50.000000E](#) [SIT8003AC-11-33S-2.04800X](#) [SiT8256AC-23-33E-156.250000X](#) [SIT8918AA-11-33S-50.000000G](#) [SM4420TEV-40.0M-T1K](#) [SMA4306-TL-H](#) [F335-24](#) [F335-40](#) [F335-50](#) [F535L-10](#) [F535L-12](#) [F535L-16](#) [F535L-27](#) [F535L-48](#) [PE7744DW-100.0M](#) [CSX750FBC-20.000M-UT](#) [CSX-750FBC33333000T](#) [CSX750FBC-4.000M-UT](#) [CSX750FBC-7.3728M-UT](#) [CSX750FBC-8.000M-UT](#) [CSX-750FCC14745600T](#) [CSX750FCC-16.000M-UT](#) [CSX-750FCC40000000T](#) [CSX750FCC-4.000M-UT](#) [ASA-22.000MHZ-L-T](#) [ASA2-26.000MHZ-L-T](#) [ASA-40.000MHZ-L-T](#) [ASA-48.000MHZ-L-T](#) [ASA-60.000MHZ-L-T](#) [ASF1-3.686MHZ-N-K-S](#) [XLH735025.000JU4I8](#) [XLP725125.000JU6I8](#) [XO37CTECNA10M](#) [XO57CRECNA16M](#)