

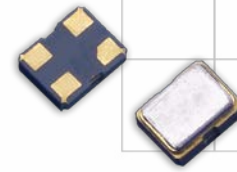

# Model CA20

## AUTOMOTIVE GRADE HCMOS CLOCK



Part Dimensions:  
2.0 × 1.6 × 0.8mm • 8.29998mg

### Features

- AEC-Q200 Compliant
- Ceramic Surface Mount Package
- Operating Temperature Range to -55°C to +105°C
- Fundamental and 3<sup>rd</sup> Overtone Crystal Designs
- Frequency Range 1.25 – 100MHz
- +1.8V, +2.5V and +3.3V Operation
- Output Enable Standard
- Tape and Reel Packaging, EIA-418

#### Standard Frequencies

\* See Page 6 for common frequencies.  
Check with factory for availability of frequencies not listed.

### Applications

- Automotive Electronics
- Audio/Video Systems
- Medical Electronics
- Mobile Multimedia/Infotainment
- Wireless Communication
- Commercial Military & Aerospace

### Description

CTS Model CA20 is a low cost, small size, Clock Oscillator [XO] developed for use in automotive electronics operating over extended temperature ranges. CA20 has an HCMOS/TTL compatible output, offers excellent stability and low jitter/phase noise performance.

### Ordering Information

Model		Output Type	Frequency Code [MHz]	Frequency Stability	Temperature Range	Supply Voltage	Packaging
CA	20	C	XXX or XXXX	3	G	3	T
Code Package Size		Code Frequency		Code Temp. Range		Code Packing	
20	2.0x1.6mm	Product Frequency Code <sup>1</sup>		I -40°C to +85°C <sup>2</sup> G -40°C to +105°C <sup>3</sup> H -40°C to +125°C <sup>4</sup> N -40°C to +150°C <sup>5</sup> P -55°C to +105°C <sup>5</sup>		T 1k pcs./reel	
Code Output		Code Stability		Code Voltage			
C HCMOS		5 ±25ppm 4 ±30ppm 3 ±50ppm 2 ±100ppm 7 ±150ppm		M +1.8Vdc N +2.5Vdc L +3.3Vdc			

Notes:

- 1] Refer to document 016-1454-0, Frequency Code Tables. 3-digits for frequencies <100MHz, 4-digits for frequencies 100MHz or greater.
- 2] Available with all stability codes.
- 3] Available with stability codes 4, 3, 2 and 7.
- 4] Available with stability codes 3, 2 and 7.
- 5] Stability codes 2 and 7. Contact factory for availability.

**Not all performance combinations and frequencies may be available.  
Contact your local CTS Representative or CTS Customer Service for availability.**

This product is specified for use only in standard commercial applications. Supplier disclaims all express and implied warranties and liability in connection with any use of this product in any non-commercial applications or in any application that may expose the product to conditions that are outside of the tolerances provided in its specification.



## Electrical Specifications

### Operating Conditions

PARAMETER	SYMBOL	CONDITIONS	MIN	TYP	MAX	UNIT
Maximum Supply Voltage	$V_{CC}$	-	-0.5	-	4.0	V
Supply Voltage	$V_{CC}$	±5%	1.710	1.8	1.890	V
			2.375	2.5	2.665	
			3.135	3.3	3.465	
Typical @ Nominal $V_{CC}$ , $C_L = 15$ pF, $T_A = +25^\circ\text{C}$						
Supply Current	$I_{CC}$	@ +1.8V	-	6	15	mA
		@ +2.5V	-	7	15	
		@ +3.3V	-	8	20	
Output Load	$C_L$	-	-	-	15	pF
Operating Temperature	$T_A$	-	-40	-	+85	°C
			-40	-	+105	
			-40	+25	+125	
			-40	-	+150	
			-55	-	+105	
			-55	-	+125	
Storage Temperature	$T_{STG}$	-	-55	-	+125	°C

### Frequency Stability

PARAMETER	SYMBOL	CONDITIONS	MIN	TYP	MAX	UNIT
Frequency Range	$f_O$	-		1.25 - 100		MHz
Frequency Stability [Note 1]	$\Delta f/f_O$	-		25, 30, 50, 100 or 150		±ppm
Aging	$\Delta f/f_{25}$	First Year @ +25°C, nominal $V_{CC}$	-5	-	5	ppm

1.] Inclusive of initial tolerance at time of shipment, changes in supply voltage, load, temperature and 1st year aging.

### Output Parameters

PARAMETER	SYMBOL	CONDITIONS	MIN	TYP	MAX	UNIT
Output Type	-	-		HCMOS		-
Output Voltage Levels	$V_{OH}$	Logic '1' Level, CMOS Load	$0.9V_{CC}$	-	-	V
	$V_{OL}$	Logic '0' Level, CMOS Load	-	-	$0.1V_{CC}$	
Output Current Levels	$I_{OH}$	$V_{OH} = 90\%V_{CC}$ [1.8V, 2.5V, 3.3V]	-	-	-4, -4, -8	mA
	$I_{OL}$	$V_{OL} = 10\%V_{CC}$ [1.8V, 2.5V, 3.3V]	-	-	+4, +4, +8	
Output Duty Cycle	SYM	@ 50% Level	45	-	55	%
@ 10%/90% Levels, Nominal $V_{CC}$ , $C_L = 15$ pF						
Rise and Fall Time [Note 2]	$T_R, T_F$	@ +1.8V	-	6	7	ns
		@ +2.5V	-	5	7	
		@ +3.3V	-	5	7	
Start Up Time	$T_S$	Application of $V_{CC}$	-	2	5	ms

2.] Parameters are worst case and account for comprehensive range of product specification. Performance may vary by application and must be validated by end user.

## Electrical Specifications

### Output Parameters

PARAMETER	SYMBOL	CONDITIONS	MIN	TYP	MAX	UNIT
Enable Function		Standby				
Enable Input Voltage	$V_{IH}$	Pin 1 Logic '1', Output Enabled	$0.7V_{CC}$	-	-	V
Disable Input Voltage	$V_{IL}$	Pin 1 Logic '0', Output Standby	-	-	$0.3V_{CC}$	V
Enable Current	$I_{STB}$	Pin 1 Logic '0', Output Standby	-	-	10	$\mu A$
Enable Time	$T_{PLZ}$	Pin 1 Logic '1'	-	-	5	ms
Phase Jitter, RMS	$t_{jrms}$	Bandwidth 12 kHz - 20 MHz	-	0.5	<1	ps

### Enable Truth Table

Pin 1	Pin 3
Logic '1'	Output
Open	Output
Logic '0'	High Imp.

### Test Circuit

HCMOS

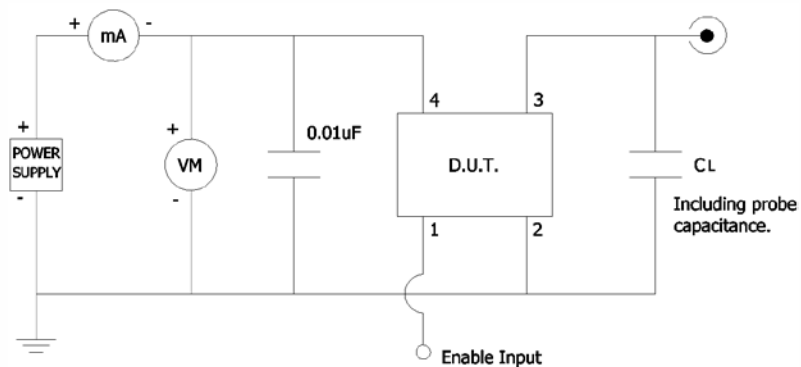

### Output Waveform

HCMOS

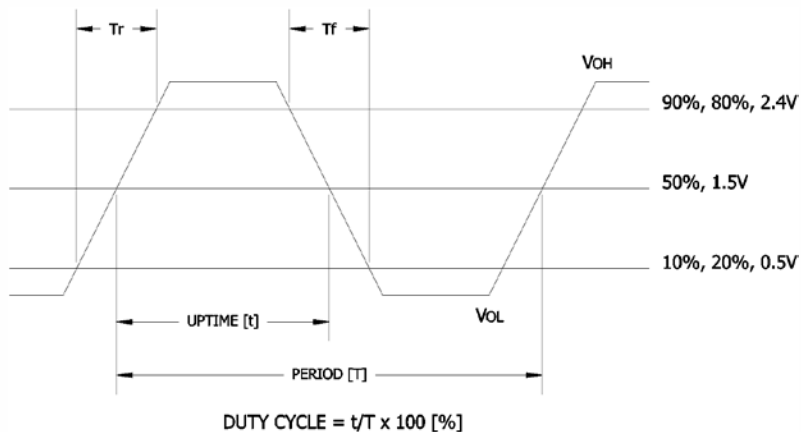

## Mechanical Specifications

### Package Drawing

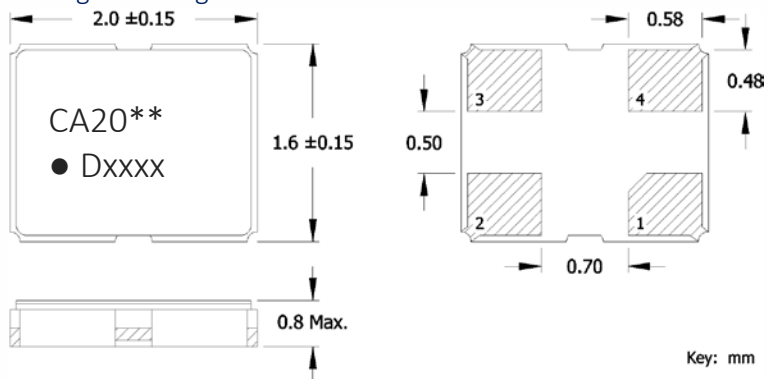

### Marking Information

1. CA20 – CTS model.
2. \*\* – Manufacturing Site Code.
3. ● – Pin 1 identifier.
4. D – Date Code. See Table I for codes.
5. xxxx – Frequency Code.  
3-digits for frequencies <100MHz  
4-digits for frequencies 100MHz or greater  
[See document 016-1454-0, Frequency Code Tables.]

### Recommended Pad Layout

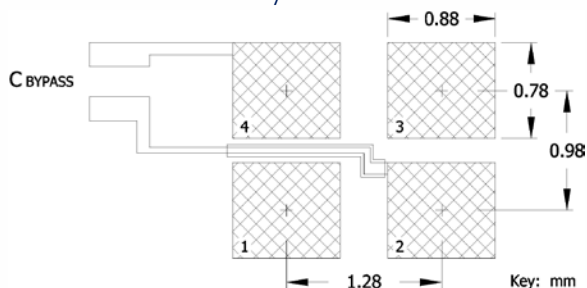

### Notes

1. Termination pads (e4). Barrier-plating is nickel [Ni] with gold [Au] flash plate.
2. Reflow conditions per JEDEC J-STD-020; +260°C maximum, 20 seconds.
3. MSL = 1.

### Pin Assignments

Pin	Symbol	Function
1	EOH	Enable
2	GND	Circuit & Package
3	Output	RF Output
4	V <sub>CC</sub>	Supply Voltage

Table I - Date Code

YEAR		MONTH														
		JAN	FEB	MAR	APR	MAY	JUN	JUL	AUG	SEP	OCT	NOV	DEC			
2001	2005	2009	2013	2017	A	B	C	D	E	F	G	H	J	K	L	M
2002	2006	2010	2014	2018	N	P	Q	R	S	T	U	V	W	X	Y	Z
2003	2007	2011	2015	2019	a	b	c	d	e	f	g	h	j	k	l	m
2004	2008	2012	2016	2020	n	p	q	r	s	t	u	v	w	x	y	z

### Packaging - Tape and Reel

#### Tape Drawing

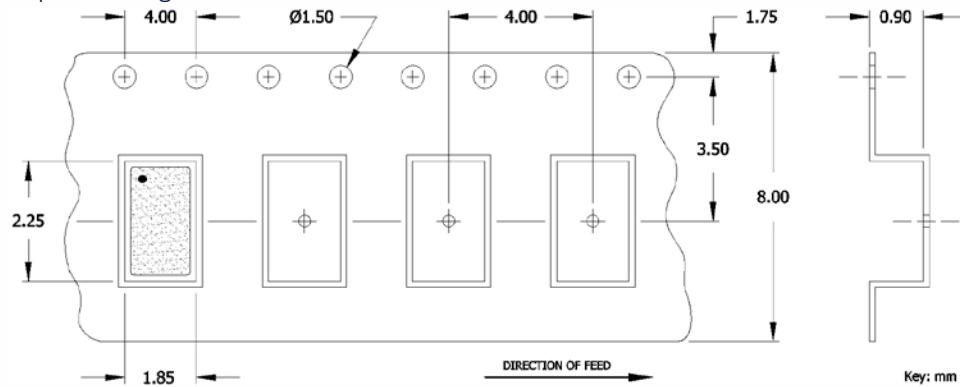

#### Reel Drawing

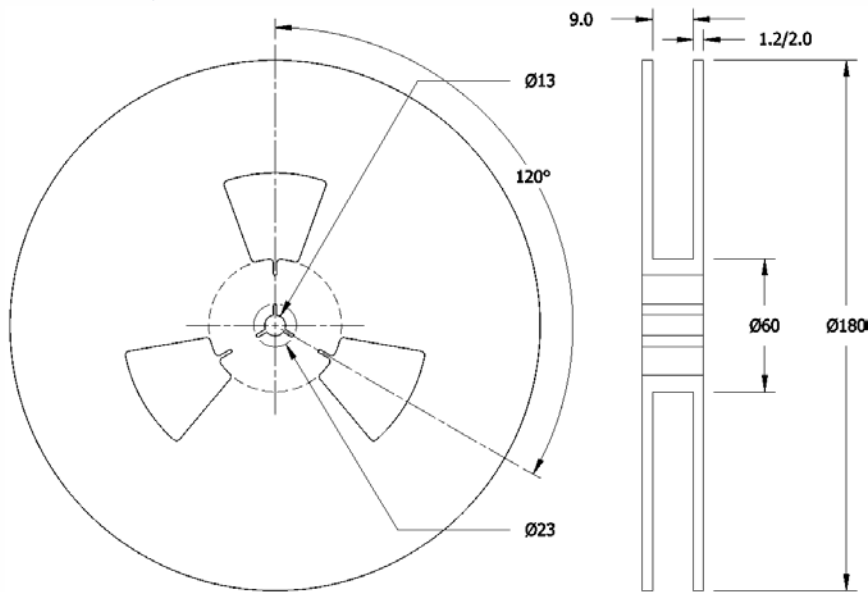

#### Notes

1. Device quantity is 1k pieces minimum and 3k pieces maximum per 180mm reel.
2. Complete CTS part number, frequency value and date code information must appear on reel and carton labels.



## Addendum

### Common Frequencies Available – MHz

FREQUENCY	FREQUENCY CODE	FREQUENCY	FREQUENCY CODE	FREQUENCY	FREQUENCY CODE	FREQUENCY	FREQUENCY CODE
4.000000	040	24.000000	240	40.000000	400		
8.000000	080	24.576000	24C	48.000000	480		
10.000000	100	25.000000	250	50.000000	500		
12.000000	120	26.000000	260				
12.288000	122	27.000000	270				
14.318180	143	30.000000	300				
14.745600	147	32.000000	320				
16.000000	160	33.333000	33E				
20.000000	200	37.400000	374				
22.118400	221	38.400000	384				

## X-ON Electronics

Largest Supplier of Electrical and Electronic Components

*Click to view similar products for [Standard Clock Oscillators](#) category:*

*Click to view products by [CTS](#) manufacturer:*

Other Similar products are found below :

[601252](#) [F335-25](#) [F535L-33.333](#) [F535L-50](#) [ECS-2018-160-BN-TR](#) [MXO45HS-2C-66.6666MHZ](#) [SiT1602BI-22-33E-50.000000E](#) [SiT8209AI-32-33E-125.000000](#) [SIT8918AA-11-33S-50.000000G](#) [SM4420TEV-40.0M-T1K](#) [F335-24](#) [F335-40](#) [F535L-10](#) [F535L-12](#) [F535L-16](#) [F535L-24](#) [F535L-27](#) [F535L-48](#) [PE7744DW-100.0M](#) [CSX-750FCC14745600T](#) [ASF1-3.686MHZ-N-K-S](#) [XO57CTECNA3M6864](#) [ECS-2100A-147.4](#) [601251](#) [EP16E7E2H26.000MTR](#) [SIT8918AA-11-33S-16.000000G](#) [XO3003](#) [9120AC-2D2-33E212.500000](#) [9102AI-243N25E100.00000](#) [8208AC-82-18E-25.00000](#) [ASDK2-32.768KHZ-LR-T3](#) [8008AI-72-XXE-24.545454E](#) [8004AC-13-33E-133.33000X](#) [AS-4.9152-16-SMD-TR](#) [ASFL1-48.000MHZ-LC-T](#) [SIT8920AM-31-33E-25.0000](#) [DSC1028DI2-019.2000](#) [9121AC-2C3-25E100.00000](#) [9102AI-233N33E100.00000X](#) [9102AI-233N25E200.00000](#) [9102AI-232H25S125.00000](#) [9102AI-133N25E200.00000](#) [9102AC-283N25E200.00000](#) [9001AC-33-33E1-30.000](#) [3921AI-2CF-33NZ125.000000](#) [5730-1SF](#) [PXA000010](#) [8003AI-12-33S-40.00000Y](#) [1602BI-13-33S-19.200000E](#) [8208AI-2F-18E-25.000000X](#)