

FEATURES

- Standard 7x5mm Surface Mount Footprint
- HCMOS/TTL Compatible
- Fundamental and 3rd Overtone Crystals
- Frequency Range 1 – 125 MHz
- Frequency Stability, ± 50 ppm Standard (± 25 ppm and ± 20 ppm available)
- +2.5Vdc Operation
- Operating Temperature to -40°C to $+85^{\circ}\text{C}$
- Output Enable Standard
- Tape & Reel Packaging
- **RoHS/Green Compliant**

DESCRIPTION

The CB2V5 is a ceramic packaged Clock oscillator offering reduced size and enhanced stability. The small size means it is perfect for any application. The enhanced stability means it is the perfect choice for today's communications applications that require tight frequency control.

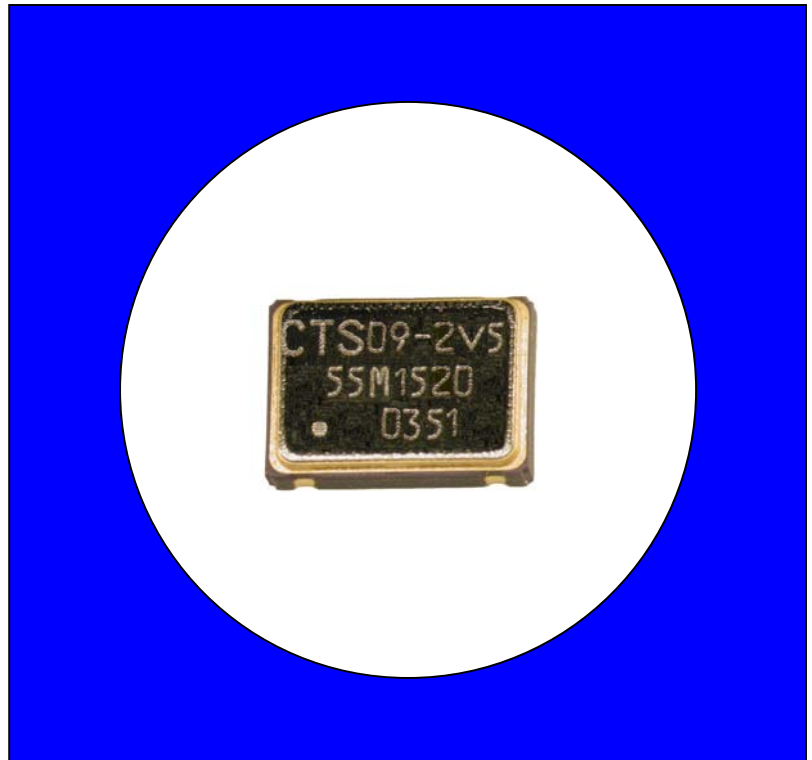

ORDERING INFORMATION

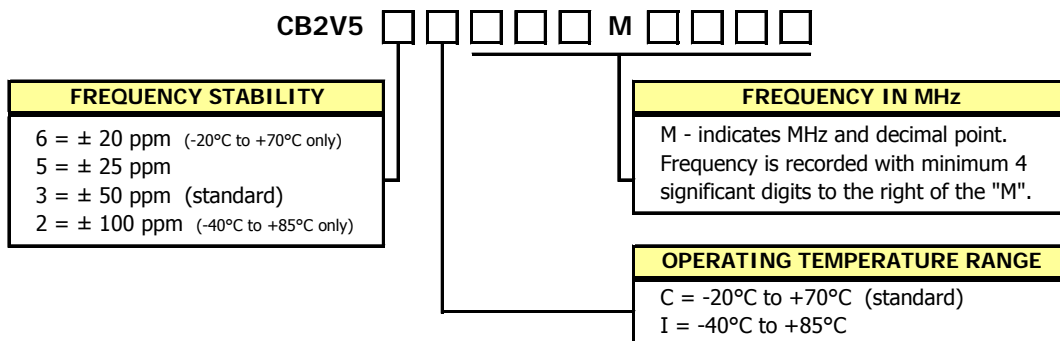

Example Part Number: CB2V53C032M7680

ELECTRICAL CHARACTERISTICS

	PARAMETER	SYMBOL	CONDITIONS	MIN	TYP	MAX	UNIT	
Absolute Maximums	Maximum Supply Voltage	V_{CC}	-	-0.5	-	7.0	V	
	Storage Temperature	T_{STG}	-	-55	-	125	°C	
	Frequency Range	f_0	-	1.0	-	125	MHz	
	Frequency Stability (See Note 1 and Ordering Information)	$\Delta f/f_0$	-	-	-	20,25,50 or 100	± ppm	
	Operating Temperature Commercial Industrial	T_A	-	-20 -40	25	70 85	°C	
Electrical and Waveform Parameters	Supply Voltage	V_{CC}	± 10 %	2.25	2.50	2.75	V	
	Supply Current	I_{CC}	1.0 MHz to 20 MHz 20.1 MHz to 50 MHz 50.1 MHz to 125 MHz	$C_L=15pF$ $C_L=15pF$ $C_L=15pF$	- - -	- - -	7 15 20	mA
	Output Load	C_L	1.0 MHz to 50 MHz 50.1 MHz to 125 MHz	- -	- -	30 15	pF	
	Output Voltage Levels Logic '1' Level Logic '0' Level	V_{OH} V_{OL}	- -	90% V_{CC} -	- -	- 10% V_{CC}	V	
	Output Current Logic '1' Level Logic '0' Level	I_{OH} I_{OL}	$V_{OH} = 90\%V_{CC}$ $V_{OL} = 10\%V_{CC}$	- -	- -	-4 +4	mA	
	Output Duty Cycle	SYM	@ 50% Level	45	-	55	%	
	Rise and Fall Time	T_{Rv} T_F	@ 10% - 90% Levels 1.0 MHz to 20 MHz 20.1 MHz to 50 MHz 50.1 MHz to 125 MHz	$C_L=15pF$ $C_L=15pF$ $C_L=15pF$	- - -	6 3 1.5	8 4 3	ns
	Start Up Time	T_S	Application of V_{CC}	-	-	10	ms	
	Enable Function Enable Input Voltage Disable Input Voltage	V_{IH} V_{IL}	Pin 1 Logic '1', Output Enabled Pin 1 Logic '0', Output Disabled	1.75 -	- -	- 0.5	V	
	Standby Current Output Enable Time	I_{ST} T_{PLZ}	$V_{IL} = 0.58V$, Oscillator Stops $V_{IH} = 1.58V$	- -	- -	10 8	µA ms	
	Phase Jitter	tjms	Bandwidth 12 kHz - 20 MHz	-	< 1	-	ps RMS	

Notes:

- Inclusive of initial tolerance at time of shipment, changes in supply voltage, load, temperature and first year aging at an average operating temperature of +40 °C.

CMOS/TTL OUTPUT WAVEFORM

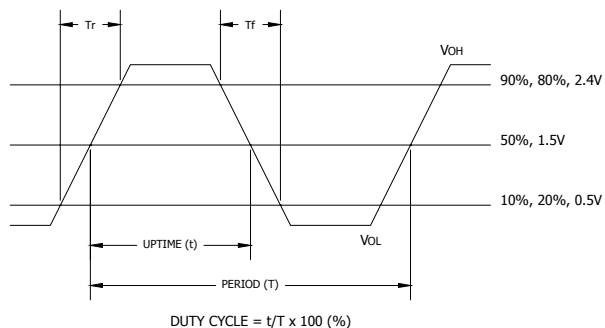

ENABLE TRUTH TABLE

PIN 1	PIN 3
Logic '1'	Output
Open	Output
Logic '0'	High Imp.

TEST CIRCUIT, CMOS LOAD

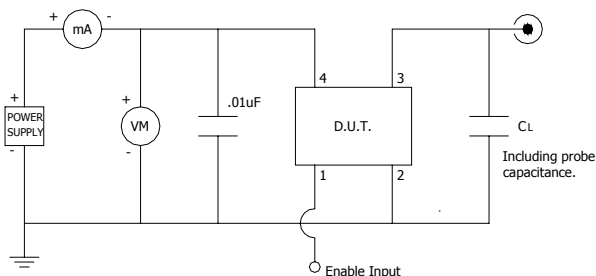

D.U.T. PIN ASSIGNMENTS

PIN	SYMBOL	DESCRIPTION
1	EOH	Enable Input
2	GND	Circuit & Package Ground
3	Output	RF Output
4	V _{CC}	Supply Voltage

MECHANICAL SPECIFICATIONS

PACKAGE DRAWING

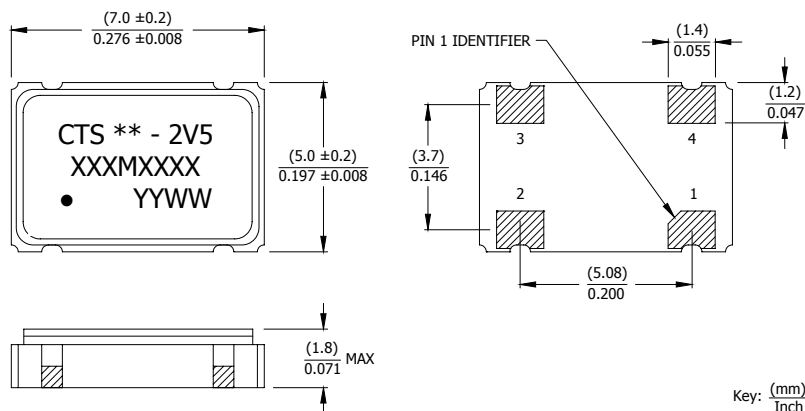

MARKING INFORMATION

- ** - Manufacturing Site Code.
- XXXMXXXX - Frequency marked with 4 significant digits after the 'M'.
- YYWW - Date code, YY - year, WW - week.

NOTES

- Termination pads (e4), barrier-plating is nickel (Ni) with gold (Au) flash plate.
- Reflow conditions per JEDEC J-STD-020.

SUGGESTED SOLDER PAD GEOMETRY

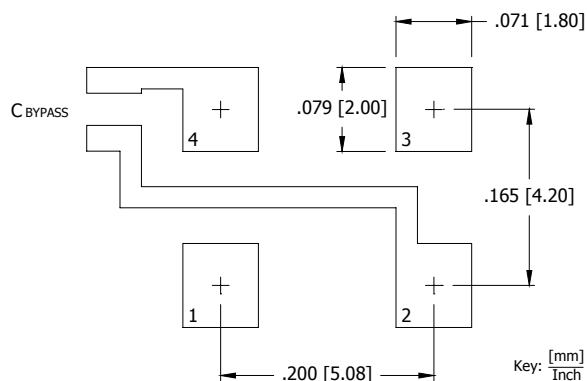

C_{BYPASS} should be ≥ 0.01 uF.

SUGGESTED REFLOW PROFILE

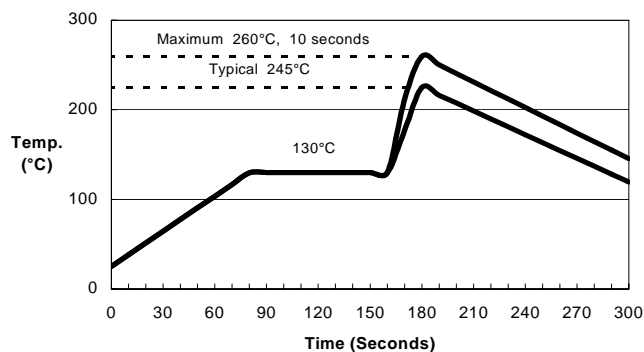

TAPE AND REEL INFORMATION

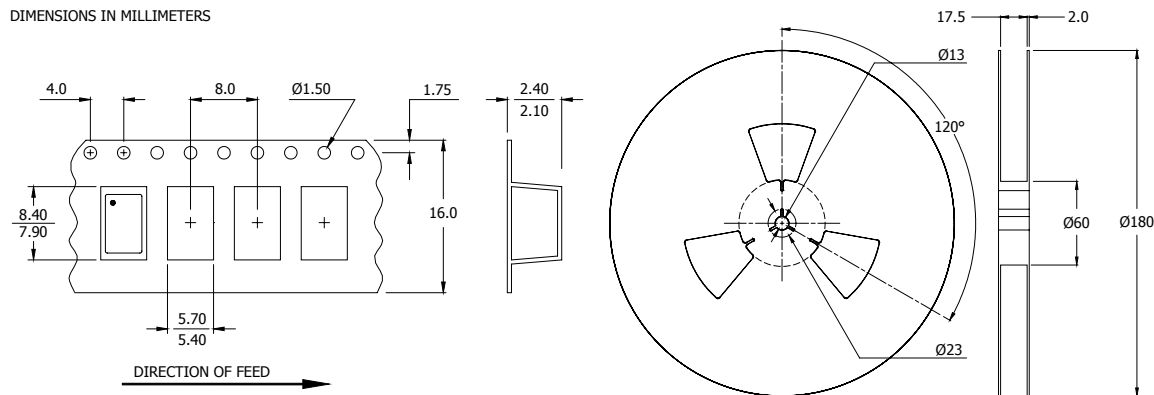

Device quantity is 1,000 pieces per 180mm reel.

ENVIRONMENTAL SPECIFICATIONS

Temperature Cycle:	400 cycles from -55°C to $+125^{\circ}\text{C}$, 10 minute dwell at each temperature, 1 minute transfer time between temperatures.
Mechanical Shock:	1,500g's, 0.5mS duration, $\frac{1}{2}$ sinewave, 3 shocks each direction along 3 mutually perpendicular planes (18 total shocks).
Sinusoidal Vibration:	0.06 inches double amplitude, 10 to 55 Hz and 20g's, 55 to 2,000 Hz, 3 cycles each in 3 mutually perpendicular planes (9 times total).
Gross Leak:	No leak shall appear while immersed in an FC40 or equivalent liquid at $+125^{\circ}\text{C}$ for 20 seconds.
Fine Leak:	Mass spectrometer leak rates less than 2×10^{-8} ATM cc/sec air equivalent.
Resistance to Solder Heat:	Product must survive 3 reflows of $+260^{\circ}\text{C}$ peak, 10 seconds maximum.
High Temperature Operating Bias:	2,000 hours at $+125^{\circ}\text{C}$, maximum bias, disregarding frequency shift.
Frequency Aging:	1,000 hours at $+85^{\circ}\text{C}$, full bias, less than ± 5 ppm shift.
Moisture Sensitivity Level:	Level 1 per JEDEC J-STD-020.

QUALITY AND RELIABILITY

Quality systems meet or exceed the requirements of ISO 9000:2000 standards.

X-ON Electronics

Largest Supplier of Electrical and Electronic Components

Click to view similar products for [Standard Clock Oscillators](#) category:

Click to view products by [CTS](#) manufacturer:

Other Similar products are found below :

[601252](#) [F335-25](#) [F535L-33.333](#) [F535L-50](#) [NBXHBA019LN1TAG](#) [SiT1602BI-22-33E-50.000000E](#) [SIT8918AA-11-33S-50.000000G](#)
[SM4420TEV-40.0M-T1K](#) [F335-24](#) [F335-40](#) [F535L-10](#) [F535L-12](#) [F535L-24](#) [F535L-27](#) [PE7744DW-100.0M](#) [ASF1-3.686MHZ-N-K-S](#) [ASV-](#)
[4.000MHZ-LCS-T](#) [XLH735025.000JU4I8](#) [XLP725125.000JU6I8](#) [XO57CTECNA3M6864](#) [601251](#) [SiT8503AI-18-33E-0.200000X](#)
[SIT8918AA-11-33S-16.000000G](#) [SIT9122AI2C233E300.000000X](#) [9120AC-2D2-33E212.500000](#) [9102AI-243N25E100.00000](#) [8208AC-82-](#)
[18E-25.00000](#) [8008AI-72-XXE-24.545454E](#) [8004AC-13-33E-133.33000X](#) [AS-4.9152-16-SMD-TR](#) [ASFL1-48.000MHZ-LC-T](#)
[632L3I004M00000](#) [SIT8920AM-31-33E-25.0000](#) [DSC1028DI2-019.2000](#) [9121AC-2C3-25E100.00000](#) [9102AI-233N33E100.00000X](#)
[9102AI-233N25E200.00000](#) [9102AI-232H25S125.00000](#) [9102AI-133N25E200.00000](#) [9102AC-283N25E200.00000](#) [9001AC-33-33E1-30.000](#)
[8103AC-13-33E-12.00000X](#) [3921AI-2CF-33NZ125.000000](#) [5730-1SF](#) [XUN736000.032768I](#) [ASV-25.000MHZ-ECS-50-T](#) [EC3925ETTTS-](#)
[100.000M TR](#) [SIT1602BC-83-33E-10.000000Y](#) [8003AI-12-33S-40.00000Y](#) [1602BI-13-33S-19.200000E](#)