

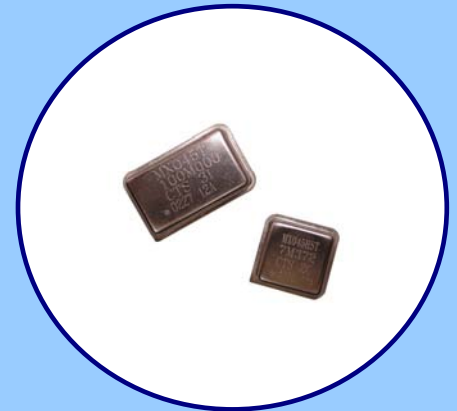

FEATURES

- Standard 14 Pin or 8 Pin DIP Packages
- HCMOS/TTL Compatible Output
- Fundamental and 3rd Overtone Crystal Designs
- Frequency Range 1 – 200 MHz
- Frequency Stability ± 50 ppm Standard
- Operating Voltage +5.0Vdc
- Operating Temperature to -40°C to +85°C
- Output Enable Standard
- Plastic Tray Packaging
- **RoHS/Green Compliant (6/6)**



APPLICATIONS

Applications for MXO45 and MXO45HS include microprocessors/DSP/FPGA, networking equipment, broadband access, storage area networks, computers and peripherals, test and measurement, Ethernet/Gigabit Ethernet.

ORDERING INFORMATION

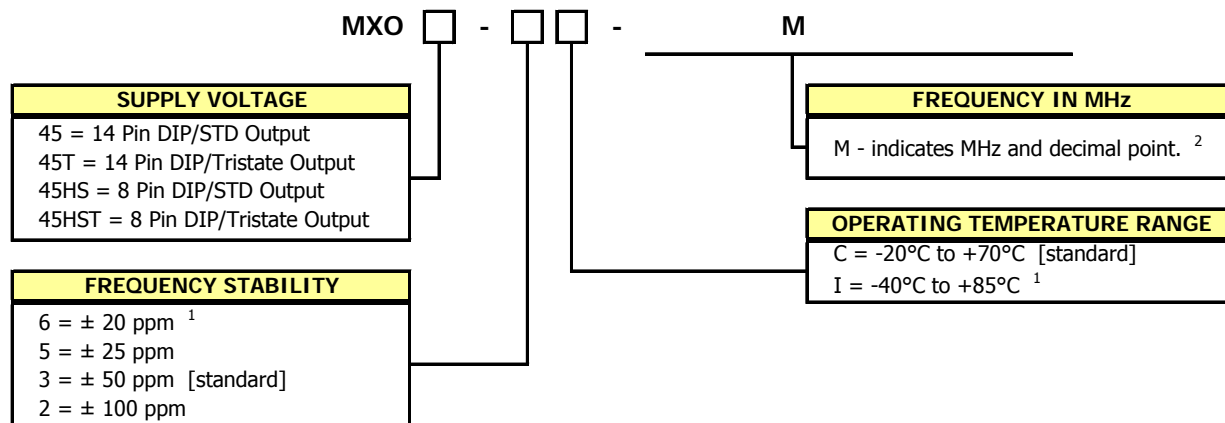

1] 6I Stability/Temperature combination is not available. Check availability for 6C combination.

2] Frequency is recorded with only leading significant digits before the 'M' and 4 - 6 significant digits after the 'M' (including zeros).

[Ex. XMXXXXXX (3M579545), XXMXXXXX (14M31818), XXXMXXXX (125M0000)]

Not all performance combinations and frequencies may be available.
Contact your local CTS Representative or CTS Customer Service for availability.

PACKAGING INFORMATION [reference]

Product is packaged in plastic trays. Typical packaging format is as follows:

- 50 pcs./Plastic Tray.
Tray size is approximately 180 x 136 x 18mm [LxWxH].
- 2 Trays per Anti-Static Bag [100 pcs.] or 10 Trays per Anti-Static Bag [500 pcs.].
Bag height for 10 Trays is approximately 175mm.
- 1 anti-static bag per cardboard carton.
- Master-pack multiple cardboard cartons in a larger carton.
8 cardboard cartons [10 trays per carton] is approximately 460 x 380 x 400mm [LxWxH].

ELECTRICAL CHARACTERISTICS

PARAMETER	SYMBOL	CONDITIONS	MIN	TYP	MAX	UNIT
Maximum Supply Voltage	V_{CC}	-	-0.5	-	+7.0	V
Storage Temperature	T_{STG}	-	-40	-	+100	°C
Frequency Range	f_0	-	1.0	-	200	MHz
Frequency Stability	$\Delta f/f_0$	See Note 1 and Ordering Information	-	-	20,25,50 or 100	± ppm
Aging	Δf	First year	-	3	5	± ppm
Operating Temperature Commercial Industrial	T_A	-	-20 -40	+25	+70 +85	°C
Supply Voltage	V_{CC}	±10%	4.5	5.0	5.5	V
Supply Current	I_{CC}	Frequency Range Tested load condition noted for typical values.				
		1.0MHz to 20MHz $C_L=50pF$	-	10	26	mA
		20.001MHz to 40MHz $C_L=30pF$	-	20	40	
		40.001MHz to 80MHz $C_L=30pF$	-	30	60	
		80.001MHz to 125MHz $C_L=15pF$	-	40	70	
		125.001MHz to 200MHz $C_L=15pF$	-	55	80	
Output Load						
CMOS	C_L	1.0MHz to 50MHz	-	-	50	pF
		50.001MHz to 80MHz	-	-	30	
		80.001MHz to 200MHz	-	-	15	
TTL		1.0MHz to 200MHz	-	-	10	TTL
Output Voltage Levels Logic '1' Level	V_{OH}	CMOS Load 10 TTL LOAD	90% V_{CC} 2.4	-	-	V
Logic '0' Level	V_{OL}	CMOS TTL Load	-	-	10% V_{CC} 0.4	
Output Current Logic '1' Level	I_{OH}	$V_{OH} = 3.9V$ $V_{CC} = 4.5V$	-	-	-16	mA
Logic '0' Level	I_{OL}	$V_{OL} = 0.4V$ $V_{CC} = 4.5V$	-	-	16	
Output Duty Cycle	SYM	@ 50% Level	45	-	55	%
Rise and Fall Time	T_{Rv} T_F	@ 10% - 90% Levels Tested load condition noted for typical values.				
		1.0MHz to 20MHz $C_L=50pF$	-	8	10	ns
		20.001MHz to 80MHz $C_L=30pF$	-	5	8	
		80.001MHz to 125MHz $C_L=15pF$	-	2.5	5	
		125.001MHz to 200MHz $C_L=15pF$	-	-	2	
Start Up Time	T_S	Application of V_{CC}	-	-	10	ms
Enable Function						
Enable Input Voltage	V_{IH}	Pin 1 Logic '1', Output Enabled	2.0	-	-	V
Disable Input Voltage	V_{IL}	Pin 1 Logic '0', Output Disabled	-	-	0.8	
Enable Time	T_{PLZ}	Pin 1 Logic '1'	-	-	200	ns
Standby Current	I_{ST}	Pin 1 Logic '0', Output Disabled	-	-	10	µA
Period Jitter, Pk-Pk	-	-	-	-	50	ps
Period Jitter, RMS	-	-	-	-	5	
Phase Jitter, RMS	-	Bandwidth 12kHz - 20MHz	-	-	1	

Notes:

- Inclusive of initial tolerance at time of shipment, changes in supply voltage, load, temperature and 1st year aging.

ELECTRICAL CHARACTERISTICS

LVC MOS OUTPUT WAVEFORM



TEST CIRCUIT, CMOS LOAD

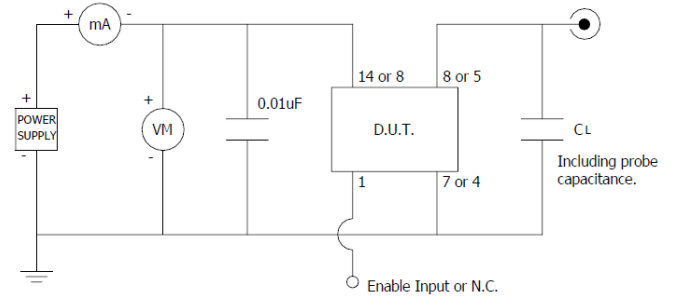

ENABLE TRUTH TABLE

PIN 1	PIN 5 or PIN 8
Logic '1'	Output
Open	Output
Logic '0'	High Imp.

D.U.T. PIN ASSIGNMENTS

PIN	SYMBOL	DESCRIPTION
1	EOH	Enable Input or No Connect
7 or 4	GND	Circuit & Package Ground
8 or 5	Output	RF Output
14 or 8	V _{CC}	Supply Voltage

MECHANICAL SPECIFICATIONS

**PACKAGE DRAWING
DIP-14**

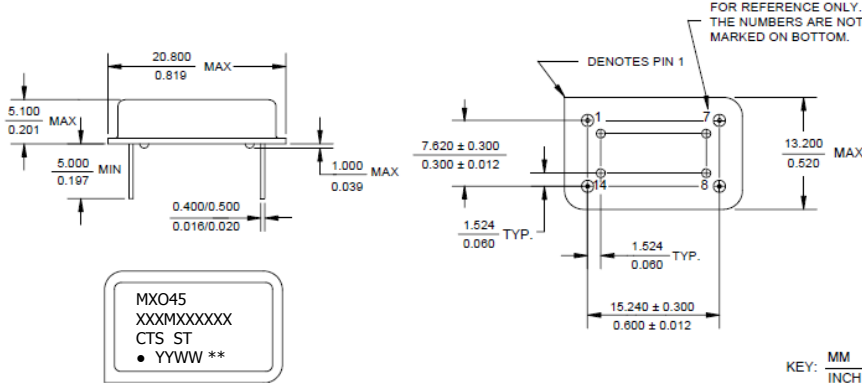

MARKING INFORMATION

- Model Name:
DIP-14 – MX045 or MX045T.
DIP-8 – MX045HS or MX045HST.
- XXXXXXXX – Frequency is marked with only leading significant digits before the 'M' and 4 – 6 digits after the 'M' (including zeros).
Ex. XMXXXXXX [3M579545]
XXMXXXXX [14M31818]
XXXMXXXX [125M0000]
- ST – Frequency stability/temperature code. [Refer to Ordering Information.]
- YYWW – Date code, YY – year, WW – week.
- ** – Manufacturing Site Code.

NOTES

- Lead finish [e1], SnAgCu.
- Reflow conditions per JEDEC J-STD-020, 260°C maximum.
- Moisture Sensitivity Level 1, per JEDEC J-STD-020.

DIP-8

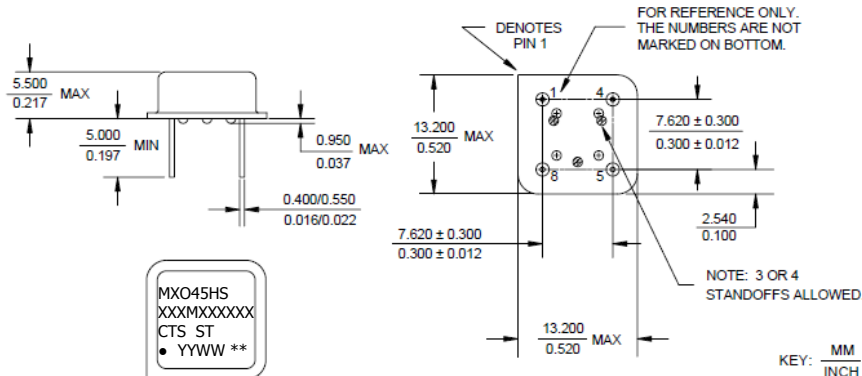

X-ON Electronics

Largest Supplier of Electrical and Electronic Components

Click to view similar products for [Standard Clock Oscillators](#) category:

Click to view products by [CTS](#) manufacturer:

Other Similar products are found below :

[EP1400SJTSC-125.000M](#) [601137](#) [601252](#) [CSX750FBC-24.000M-UT](#) [CSX750FBC-33.333M-UT](#) [CSX750FCC-3.6864M-UT](#) [F335-12](#) [F335-25](#) [DSC506-03FM2](#) [ASA-20.000MHZ-L-T](#) [ASV-20.000MHZ-LR-T](#) [ECS-2018-160-BN-TR](#) [EL13C7-H2F-125.00M](#) [MXO45HS-2C-66.6666MHZ](#) [SiT1602BI-22-33E-50.000000E](#) [SIT8003AC-11-33S-2.04800X](#) [SiT8256AC-23-33E-156.250000X](#) [SIT8918AA-11-33S-50.000000G](#) [SM4420TEV-40.0M-T1K](#) [F335-24](#) [F335-50](#) [F535L-10](#) [F535L-12](#) [F535L-16](#) [F535L-27](#) [F535L-48](#) [PE7744DW-100.0M](#) [CSX750FBC-20.000M-UT](#) [CSX-750FBC33333000T](#) [CSX750FBC-4.000M-UT](#) [CSX750FBC-7.3728M-UT](#) [CSX750FBC-8.000M-UT](#) [CSX-750FCC14745600T](#) [CSX750FCC-16.000M-UT](#) [CSX-750FCC40000000T](#) [CSX750FCC-4.000M-UT](#) [ASA-22.000MHZ-L-T](#) [ASA2-26.000MHZ-L-T](#) [ASA-3.6864MHZ-L-T](#) [ASA-40.000MHZ-L-T](#) [ASA-48.000MHZ-L-T](#) [ASA-60.000MHZ-L-T](#) [ASF1-3.686MHZ-N-K-S](#) [XO37CTECNA10M](#) [XO57CRECNA16M](#) [XO57CTECNA3M6864](#) [XO57CTECNA4M9152](#) [DSC400-0333Q0032KE1-EVB](#) [ECS-2100A-147.4](#) [EMK11H2H-26.000M](#)