

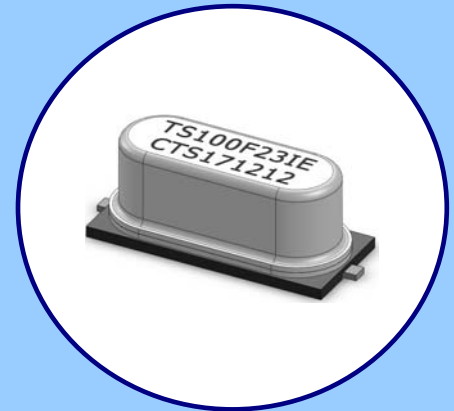

**FEATURES**

- Standard HC-49/US-SM (surface mount) Package
- Fundamental and 3<sup>rd</sup> Overtone Crystals
- Stable Frequency Over Temperature and Drive Level
- Frequency Range 3.2 – 64 MHz
- Frequency Tolerance, Options from ±10 ppm to ±30 ppm
- Frequency Stability, Options from ± 10 ppm to ±50 ppm
- Operating Temperature, -20°C to +70°C & -40°C to +85°C Standard
- Tape & Reel Packaging Standard
- **RoHS/Green Compliant (6/6)**



**APPLICATIONS**

The ATSSMTS [Tight Stability] crystal series offers excellent long-term stability and reliability in a proven resistance-weld metal package. The excellent shock performance makes it suitable for microprocessor, telecommunication, industrial, consumer electronics and networking applications.

**ORDERING INFORMATION**

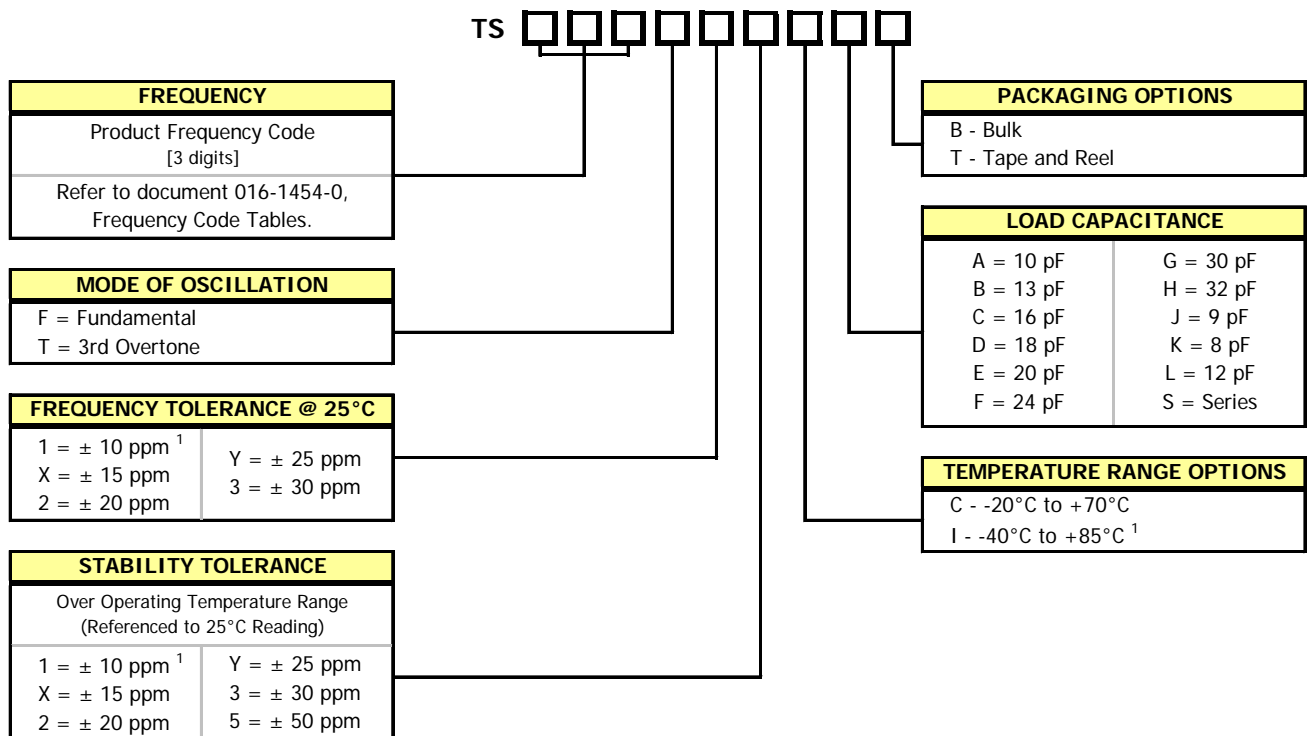

1] Check factory availability for "111" Tolerance/Stability/Temperature combination.

**Not all performance combinations and frequencies may be available.**  
Contact your local CTS Representative or CTS Inside Sales Representative for availability.

**ELECTRICAL CHARACTERISTICS**

	PARAMETER	VALUE
<b>ELECTRICAL PARAMETERS</b>	Frequency Range	3.2 MHz to 64.0 MHz
	Operating Mode	Fundamental or 3rd Overtone
	Crystal Cut	AT-Cut
	Frequency Tolerance @ +25°C *	±10, ±15, ±20, ±25, ±30 ppm
	Frequency Stability Tolerance * (Over Operating Temperature Range, Referenced to +25°C Reading)	±10, ±15, ±20, ±25, ±30, ± 50 ppm
	Operating Temperature Range *	-20°C to +70°C and -40°C to +85°C
	Equivalent Series Resistance	See ESR Table
	Load Capacitance	See Ordering Information
	Shunt Capacitance (C <sub>0</sub> )	7.0 pF Maximum
	Drive Level	100 μW Typical, 1,000 μW Maximum
	Aging @ +25°C	±3 ppm/yr Typical, ±5 ppm/yr Maximum
	Storage Temperature Range	-40°C to +85°C

\* See Ordering Information

**EQUIVALENT SERIES RESISTANCE TABLE**

FREQUENCY RANGE	OSCILLATION MODE	ESR MAXIMUM
3.20 MHz - < 4.00 MHz	Fundamental	150 Ohms
4.00 MHz - < 5.00 MHz	Fundamental	120 Ohms
5.00 MHz - < 8.00 MHz	Fundamental	80 Ohms
8.00 MHz - < 12.00 MHz	Fundamental	60 Ohms
12.00 MHz - < 20.00 MHz	Fundamental	40 Ohms
20.00 MHz - < 30.00 MHz	Fundamental	30 Ohms
27.00 MHz - 64.00 MHz	3rd Overtone	80 Ohms

**SCHEMATIC**



**MECHANICAL SPECIFICATIONS**

**PACKAGE DRAWING**

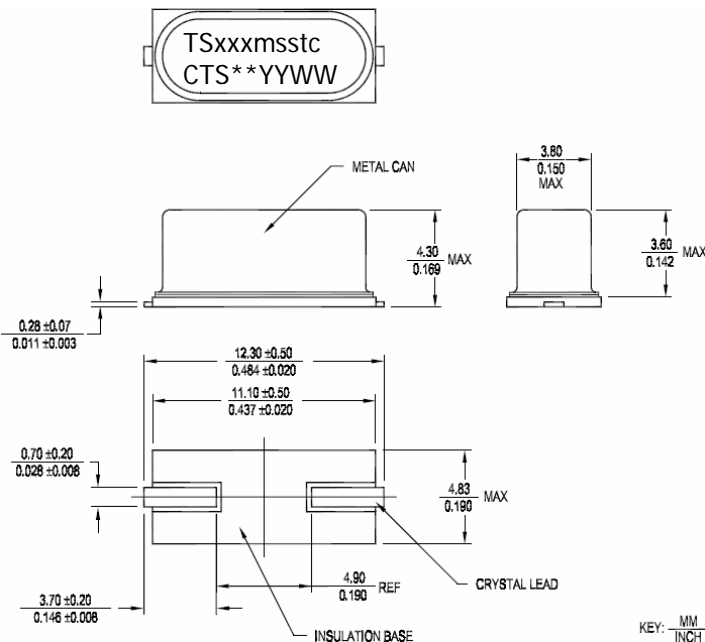

**MARKING INFORMATION**

- TSxxxmsstc – Truncated CTS Part Number. [Packaging code is not required in the marking.]
  - TS – ATSSMTS platform.
  - xxx – 3-digit Frequency Code. [Reference document 016-1454-01]
- m – Operating Mode; F = fundamental, T = 3<sup>rd</sup> Overtone.
- sstc – Tolerance, Stability, Temperature and Load Capacitance codes. Reference Ordering Information.
- \*\* - Manufacturing Site Code.
- YYWW – Date Code, YY – year, WW – week.
- Complete CTS part number, frequency value and date code information must appear on bag and box labels.

**NOTES**

- Lead finish (e1), SnAgCu.
- Reflow conditions per JEDEC J-STD-020; 260°C maximum, 10 sec.
- MSL = 1.

**SUGGESTED SOLDER PAD GEOMETRY**

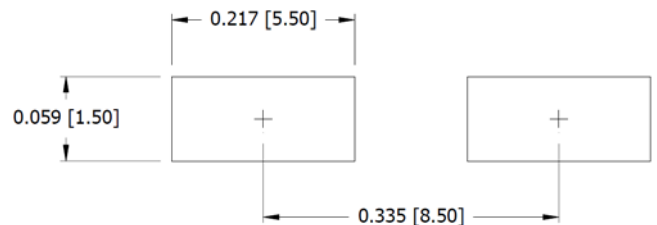

Key: Inch [mm]

**PACKAGING INFORMATION**

ATS-SM Tape and Reel [For Reference]

DIMENSIONS IN MILLIMETERS

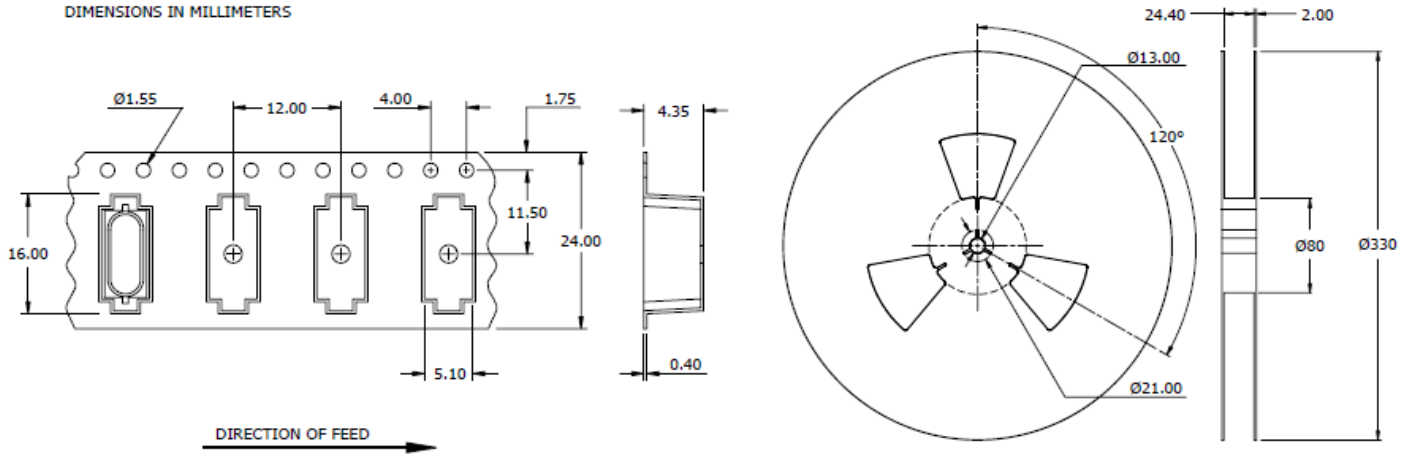

## X-ON Electronics

Largest Supplier of Electrical and Electronic Components

*Click to view similar products for [Crystals](#) category:*

*Click to view products by [CTS](#) manufacturer:*

Other Similar products are found below :

[MC405 32.0000K-R3:PURE SN](#) [7A-40.000MAAE-T](#) [MP1-8.0 99-BU](#) [9B-15.360MBBK-B](#) [PTX-A2JM-10.000M](#) [9C-7.680MBBK-T](#) [H10S-12.000-18-EXT-TR](#) [R38-32.768-12.5-5PPM-NPB](#) [BTD1062E05A-513](#) [21U15A-21.4MHZ](#) [RTX-781DF1-S-20.950](#) [LFXTAL066198Cutt](#) [9C-14.31818MBBK-T](#) [A-11.000MHZ-27](#) [SPT2A-.032768B](#) [SPT2A.032768G](#) [SSPT7F-9PF20-R](#) [FX325BS-38.88EEM1201](#) [MP-1-25.000MHZ-3L](#) [MP-1-6.000MHZ](#) [LFXTAL065253Cutt](#) [LFXTAL066431Cutt](#) [XT9S20ANA14M7456](#) [XT9SNLANA16M](#) [646G-24-2](#) [7A-24.576MBBK-T](#) [7B-30.000MBBK-T](#) [7A-14.31818MBBK-T](#) [6526-202-1501](#) [BTJ120E02C](#) [SG636PCE-20.000MC](#) [3404](#) [CM315D32768EZFT](#) [C1E-24.000-7-2020-R](#) [C1E-19.200-12-1530-X-R](#) [C1E-16.000-12-1530-X-R](#) [ABM11-16.000MHZ-9-B1U-T](#) [FL5000014](#) [EUCA18-3.1872M](#) [425F35E027M0000](#) [17196](#) [ABM3-13.52313MHZ-10-B4Y-T](#) [MS3V-T1R-32.768kHz-7pF-20PPM-TA-QC-Au](#) [VXM7-1C1-16M000](#) [MS1V-T1K-32.768kHz-10pF-20PPM-TA-QC-Au](#) [MS3V-T1R-32.768kHz-9pF-20PPM-TA-QC-Au](#) [ECS-80-18-30-JGN-TR](#) [17000](#) [17301](#)