

**SERIES:** AMT11A | **DESCRIPTION:** MODULAR INCREMENTAL ENCODER

**FEATURES**

- patented capacitive ASIC technology
- low power consumption
- incremental resolutions up to 4096 PPR
- differential line driver versions
- compact modular package with locking hub for ease of installation
- radial and axial cable connections
- 7 different mounting hole options
- -40~125°C operating temperature

**ELECTRICAL**

parameter	conditions/description	min	typ	max	units
power supply	VDD	4.5	5	5.5	V
start-up time <sup>1</sup>			200		ms
current consumption	with unloaded output		16		mA
single ended channels	output high level	VDD-0.1			V
	output low level			0.1	V
	output current (per channel)			15	mA
	rise/fall time		8		ns
differential RS-422 channels	output high level	3			V
	output low level			0.1	V
	output current (per channel)			25	mA
	rise/fall time	7	11	20	ns

Note: 1. Encoder must be stationary during start-up.

**INCREMENTAL CHARACTERISTICS**

parameter	conditions/description	min	typ	max	units
channels	CMOS Voltage (S)                      A, B Quadrature Line Driver (Q)            A, $\bar{A}$ , B, $\bar{B}$				
waveform	CMOS voltage square wave				
phase difference	A leads B for CCW rotation (viewed from front)				
quadrature resolutions <sup>2</sup>	96, 192, 200, 250, 384, 400, 500, 512 768, 800, 1000, 1024, 1600, 2000, 2048, 4096				PPR
accuracy			0.2		degrees
quadrature duty cycle (at each resolution)	96, 192, 384	49	50	51	%
	200, 250, 400, 768, 800	48	50	52	%
	500, 1000, 1600	46	50	54	%
	512, 1024, 2048, 4096	50	50	50	%
	2000	44	50	56	%

Notes: 2. Default resolution set to 4096 PPR. All resolutions are listed as pre-quadrature, meaning the final number of counts is PPR x 4.

## MECHANICAL

parameter	conditions/description	min	typ	max	units
motor shaft length		9			mm
motor shaft tolerance			NOM +0/-0.015		mm
weight	weight varies by configuration		15.7		g
axial play				±0.3	mm
rotational speed (at each resolution)	96, 192, 200, 250, 384, 400, 500, 512, 800, 1000, 1024, 2048			8000	RPM
	768, 1600, 2000, 4096			4000	RPM

## ENVIRONMENTAL

parameter	conditions/description	min	typ	max	units
operating temperature		-40		125	°C
humidity	non-condensing			85	%
vibration	10-500 Hz, 5 minute sweep, 2 hours on each XYZ			5	G
shock	3 pulses, 6 ms, 3 on each XYZ			200	G
RoHS	yes				

## WAVEFORMS

**Figure 1**

Quadrature signals with index showing counter-clockwise rotation

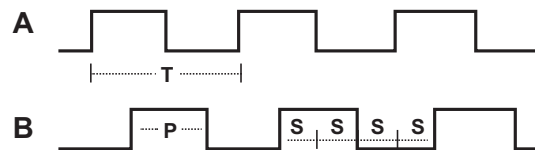

The following parameters are defined by the resolution selected for each encoder. The encoders resolution is listed as Pulses Per Revolution (PPR), which is the number of periods (or high pulses) over the encoders revolution.

Parameter	Description	Expression	Units	Notes
PPR	resolution		Pulses Per Revolution	This is the user selected value and the format all resolutions are listed in
CPR	counts	PPR x 4	Counts Per Revolution	This is the number of quadrature counts the encoder has
T	period	360/R	mechanical degrees	
P	pulse width	T/2	mechanical degrees	
S	A/B state width	T/4	mechanical degrees	This is the width of a quadrature state

Note: For more information regarding PPR, CPR, or LPR (Lines Per Revolution) view <https://www.cuidevices.com/blog/what-is-encoder-ppr-cpr-and-lpr>

## PART NUMBER KEY

For customers that prefer a specific AMT11A configuration, please reference the custom configuration key below.

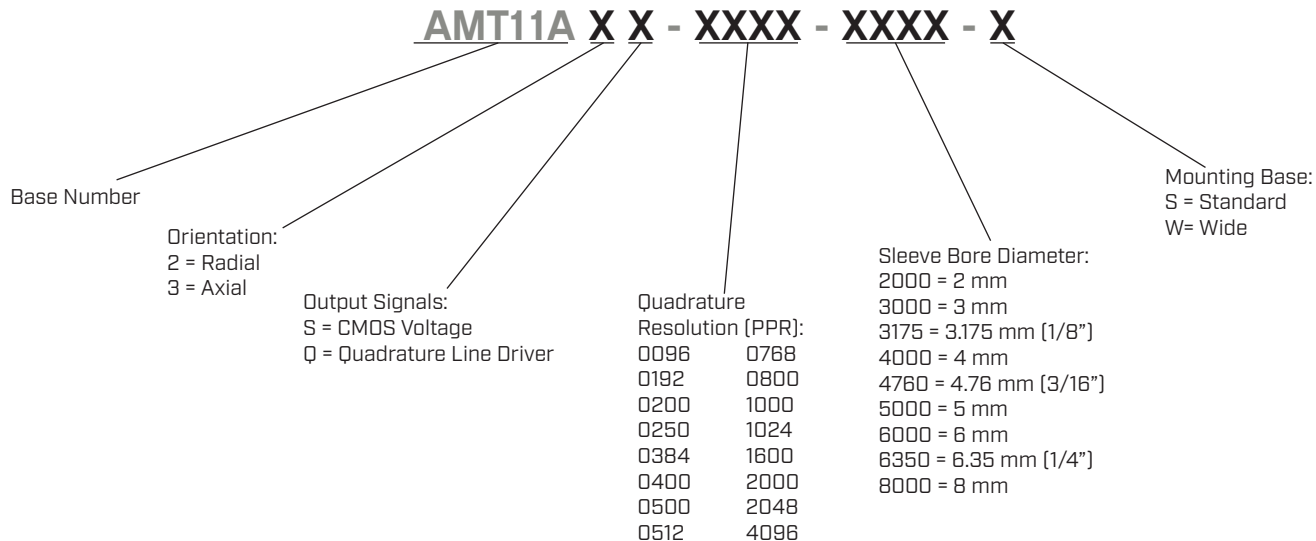

## AMT11A-V KITS

In order to provide maximum flexibility for our customers, the AMT11A series is provided in kit form standard. This allows the user to implement the encoder into a range of applications using one sku#, reducing engineering and inventory costs.

### ORDERING GUIDE

**AMT11AXX-V**

**Orientation:**  
2 = Radial  
3 = Axial

**Output Signals:**  
S = CMOS Voltage  
Q = Quadrature Line Driver

SLEEVES								
2mm	3mm	1/8 inch (3.175mm)	4mm	3/16 inch (4.76mm)	5mm	6mm	1/4 inch (6.35mm)	8mm
Light Sky Blue	Orange	Purple	Gray	Yellow	Green	Red	Snow	Blue

BASE	WIDE BASE	TOP COVER	SHAFT ADAPTER	TOOL A	TOOL C

## RESOLUTION SETTINGS

1 = On, 0 = Off

Resolution (PPR)	Maximum RPM	1	2	3	4
4096	4000	0	0	0	0
2048	8000	0	0	1	0
2000	4000	1	0	0	0
1600	4000	0	1	0	0
1024	8000	0	0	0	1
1000	8000	1	0	1	0
800	8000	0	1	1	0
768	4000	1	1	0	0
512	8000	0	0	1	1
500	8000	1	0	0	1
400	8000	0	1	0	1
384	8000	1	1	1	0
250	8000	1	0	1	1
200	8000	0	1	1	1
192	8000	1	1	0	1
96	8000	1	1	1	1

### DIP switch:

Example setting: 1000 PPR

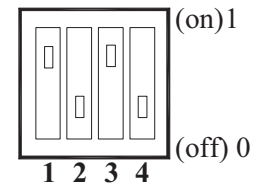

## ENCODER INTERFACE

PINOUT CONNECTOR				
Function				
#	AMT11A2S	AMT11A2Q	AMT11A3S	AMT11A3Q
1	N/A	N/A	N/A	N/A
2	N/A	N/A	N/A	N/A
3	N/A	N/A	N/A	N/A
4	GND <sup>1</sup>	GND <sup>1</sup>	GND <sup>1</sup>	GND <sup>1</sup>
5	N/A	N/A	N/A	N/A
6	+5 V	+5 V	+5 V	+5 V
7	N/A	N/A	N/A	N/A
8	B+	B+	B+	B+
9	N/A	B-	N/A	B-
10	A+	A+	A+	A+
11	N/A	A-	N/A	A-
12	N/A	N/A	N/A	N/A
13	N/A	N/A	N/A	N/A
14	N/A	N/A	N/A	N/A
15	N/A	N/A	N/A	N/A
16	N/A	N/A	N/A	N/A
17	N/A	N/A	N/A	N/A

Note: 1. Connect encoder GND to motor chassis as closely as possible. For additional grounding techniques contact CUI Devices Application Support.

### AMT11A2S & AMT11A2Q AMT11A3S & AMT11A3Q

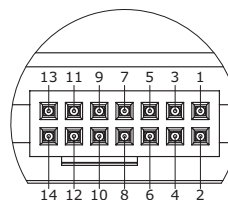
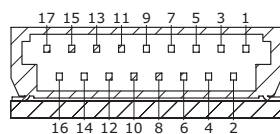
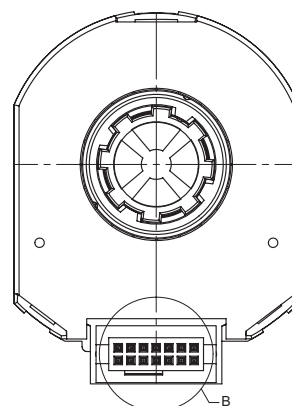
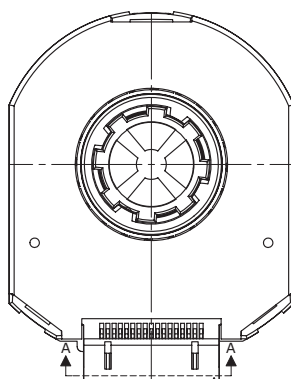

SECTION A-A  
SCALE 4 : 1

DETAIL B  
SCALE 4 : 1

Mating Connector:  
JAE FI-W17S

Mating Connector:  
Samtec ISDF-07-D-L

## MECHANICAL DRAWING

### AMT11A2S & AMT11A2Q

units: mm[inch]

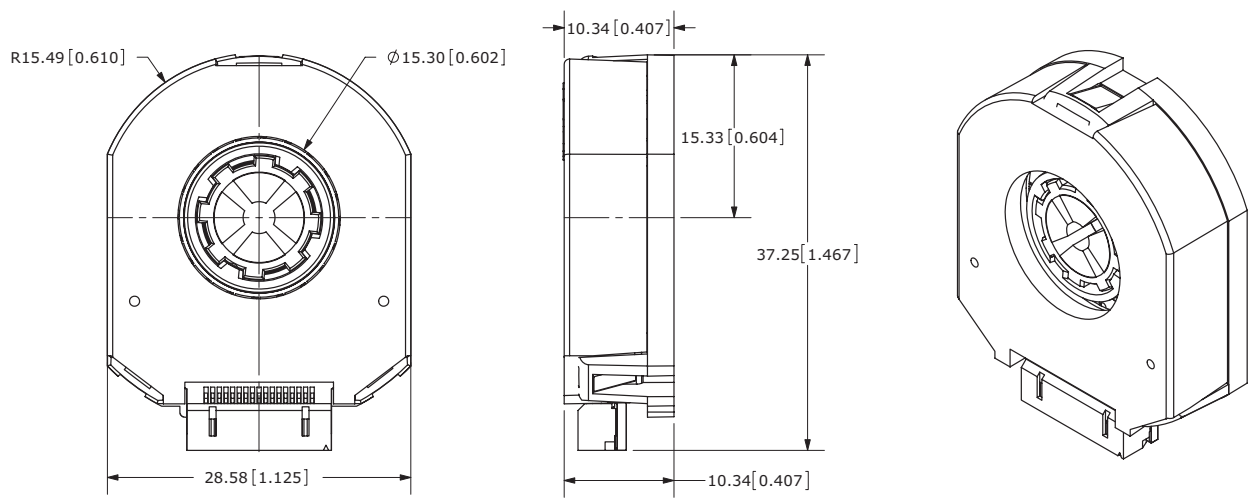
tolerance:  $\pm 0.1$ 

### AMT11A3S & AMT11A3Q

units: mm[inch]

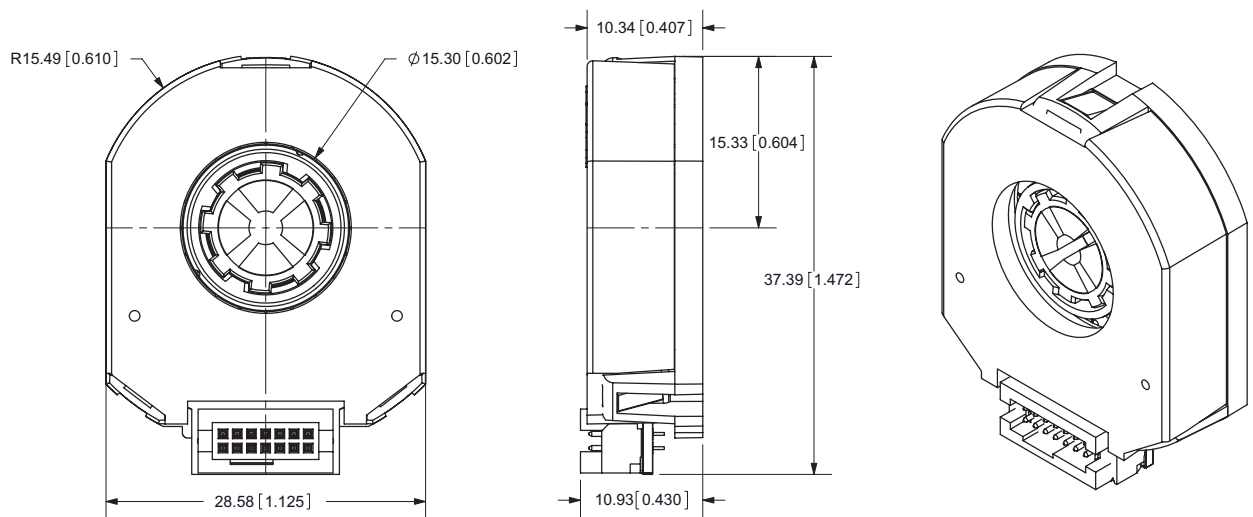
tolerance:  $\pm 0.1$ 

## MECHANICAL DRAWING (CONTINUED)

### MOUNTING HOLE PATTERNS

#### STANDARD BASE

units: mm[inch]  
tolerance: ±0.1

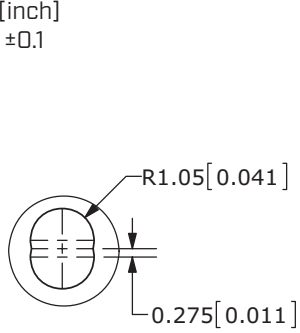

DETAIL A  
SCALE 4 : 1

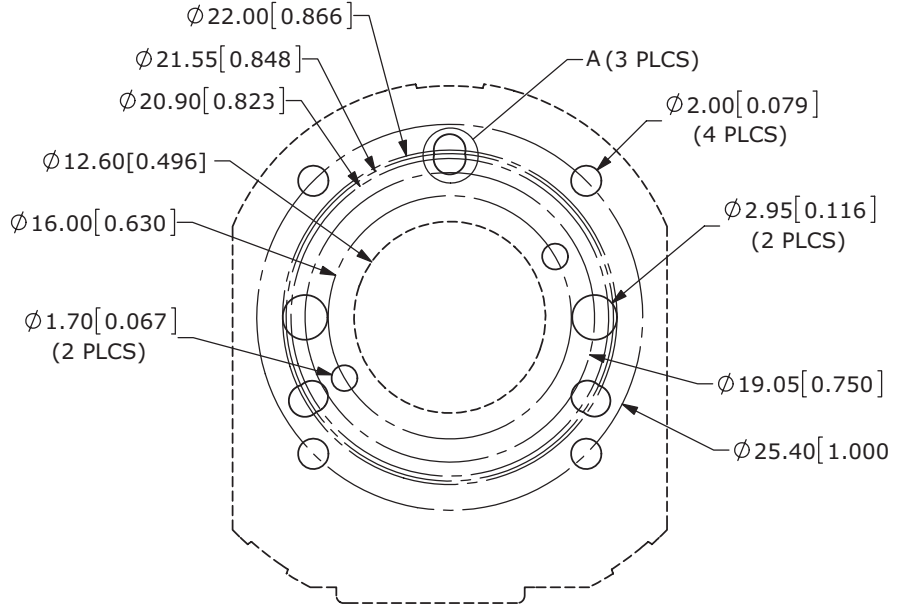

#### WIDE BASE

units: mm[inch]  
tolerance: ±0.1

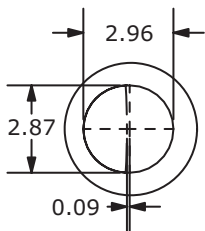

DETAIL A  
SCALE 4 : 1

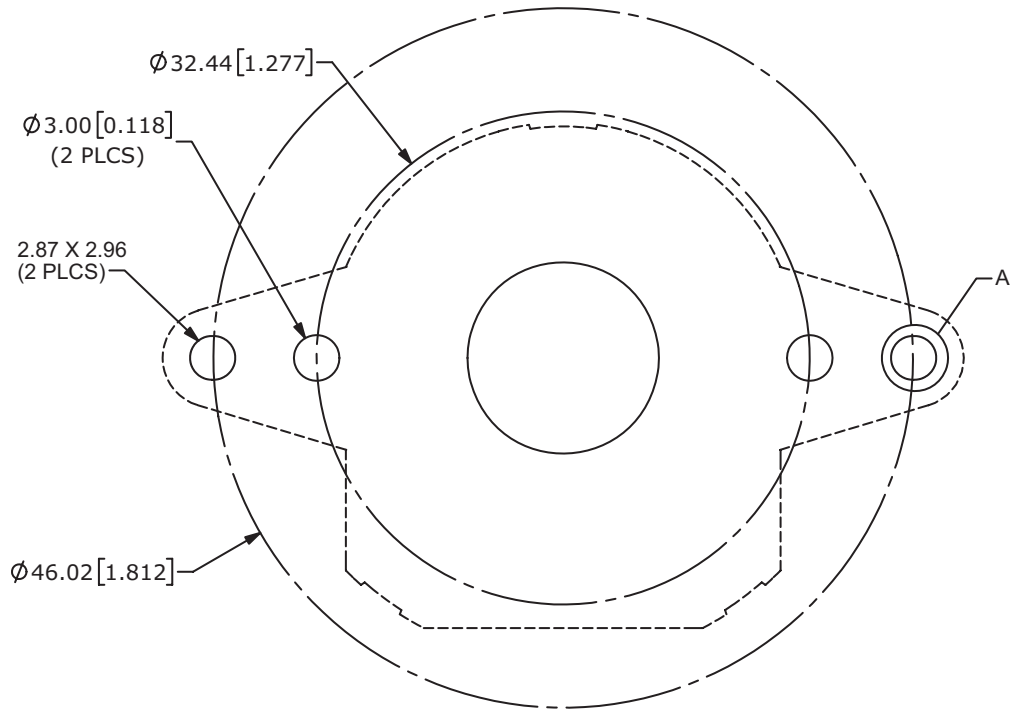

## ASSEMBLY PROCEDURE

### STEP 1

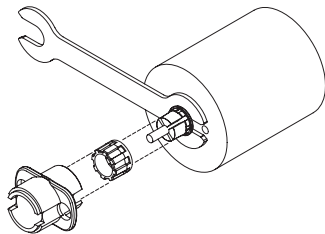

1. Insert Tool A as a spacer that defines the distance to the mounting surface.
2. Slide appropriate sized Sleeve over shaft all the way down to Tool A.
3. Slide Shaft Adaptor over Sleeve.
4. Use Tool C to press Shaft Adaptor over Sleeve [ensure Shaft Adaptor and Tool C spline alignment] until flush with Tool A.

### STEP 2

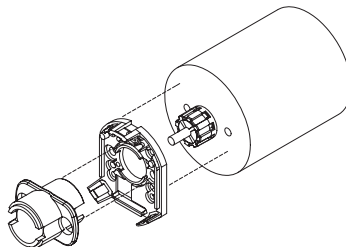

1. Remove Tools A and C.
2. Place Base on motor, with Tool C used as a centering tool.

### STEP 3

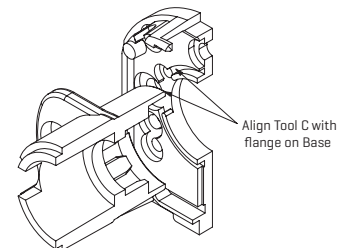

1. Align Tool C with flange on Base.
2. Slide Base and Tool C onto motor, centering onto the Shaft Adaptor.

### STEP 4



1. Fasten the Base on the motor (Tool C may need to be rotated to allow for some mounting configurations).
2. Remove Tool C.

### STEP 5

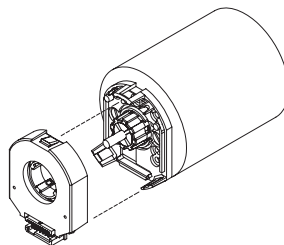

1. Snap the Top Cover onto the Base, carefully observing that the teeth of the Shaft Adaptor align with the grooves in the hub. \*

\* We recommend no more than three cycles of mounting and removal of the AMT top cover base. Multiple cycles of mounting and removing the top cover can cause base fatigue over time and affect encoder performance.

### STEP 6

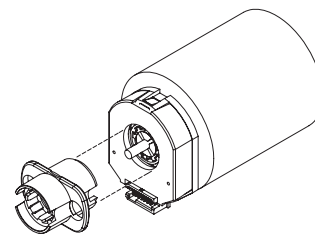

1. Make sure the snaps are fully engaged by pressing on the Hub with the reverse side of Tool C.
2. When assembly is finished, the Shaft Adaptor, Sleeve and Rotor Hub should all be flush with the Motor Shaft rotating freely.



## REVISION HISTORY

rev.	description	date
1.0	initial release	11/18/2021
1.01	logo, datasheet style update	08/05/2022

The revision history provided is for informational purposes only and is believed to be accurate.



CUI Devices offers a one (1) year limited warranty. Complete warranty information is listed on our website.

CUI Devices reserves the right to make changes to the product at any time without notice. Information provided by CUI Devices is believed to be accurate and reliable. However, no responsibility is assumed by CUI Devices for its use, nor for any infringements of patents or other rights of third parties which may result from its use.

CUI Devices products are not authorized or warranted for use as critical components in equipment that requires an extremely high level of reliability. A critical component is any component of a life support device or system whose failure to perform can be reasonably expected to cause the failure of the life support device or system, or to affect its safety or effectiveness.

[cuidevices.com](http://cuidevices.com)

## X-ON Electronics

Largest Supplier of Electrical and Electronic Components

*Click to view similar products for [Encoders](#) category:*

*Click to view products by [CUI Devices](#) manufacturer:*

Other Similar products are found below :

[01002-10603](#) [01002-10620](#) [01002-10699](#) [01002-10869](#) [01002-2133](#) [01002-289](#) [01002-4396](#) [01002-4774](#) [01002-5171](#) [01002-5462](#) [01002-6518](#) [01002-7009](#) [01002-7027](#) [01002-7157](#) [01002-7192](#) [01002-7481](#) [01002-7573](#) [01002-7683](#) [01002-7726](#) [01002-7762](#) [01002-7768](#) [01002-8053](#) [01002-8122](#) [01002-8254](#) [01002-8291](#) [01002-8366](#) [01002-8458](#) [01002-8460](#) [01002-8491](#) [01002-8500](#) [01002-8569](#) [01002-8639](#) [01002-8691](#) [01002-8715](#) [01002-8720](#) [01002-9001](#) [01002-9157](#) [01002-9191](#) [01002-9217](#) [01002-9233](#) [01002-9248](#) [01002-9255](#) [01002-9293](#) [01002-9375](#) [01002-9572](#) [01002-9621](#) [01002-9657](#) [01002-9694](#) [01002-9753](#) [01002-9959](#)