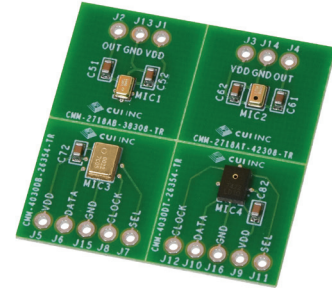

**MODEL:** DEVKIT-MEMS-001 | **DESCRIPTION:** MICROPHONE DEVELOPMENT KIT**FEATURES**

- 4 detachable evaluation boards
- 2 digital MEMS, one top port & one bottom port
- 2 analog MEMS, one top port & one bottom port
- plated through hole I/O terminals for multiple testing options

**EVAL BOARD**

	circuit	technology	output	acoustic port	size (mm)	sensitivity typ (dB)	current typ (μA)
CMM-2718AB-38308-TR	MIC1	MEMS	analog	bottom	2.75 x 1.85	-38	80
CMM-2718AT-42308-TR	MIC2	MEMS	analog	top	2.75 x 1.85	-42	80
CMM-4030DB-26354-TR	MIC3	MEMS	digital	bottom	4.0 x 3.0	-26	540
CMM-4030DT-26354-TR	MIC4	MEMS	digital	top	4.0 x 3.0	-26	540

**OPERATIONAL INSTRUCTIONS**

The CUI Devices MEMS microphone evaluation board consists of four independent microphone evaluation circuits. Two of the microphones provide analog output signals and two of the microphones provide digital output signals. Top and bottom sound port options are provided for both the analog and the digital output microphones. External bypass capacitors are included on the power supply rails of the evaluation boards and DC blocking capacitors are placed in the analog output signal paths.

A DC power supply of 1.6~3.6 Volts should be connected between the VDD and GND pins of the board to be evaluated. Please refer to the respective data sheets for proper connections to the remaining signal pins.

## CIRCUIT DIAGRAMS & BOARD LAYOUTS

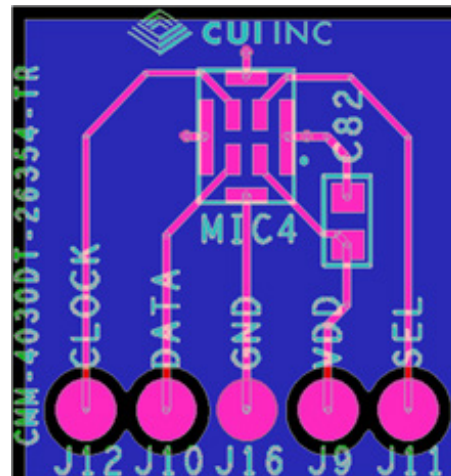
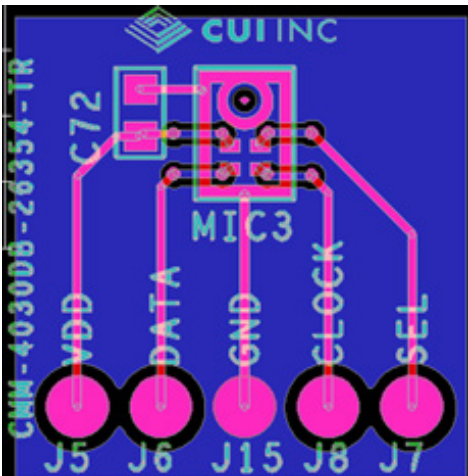
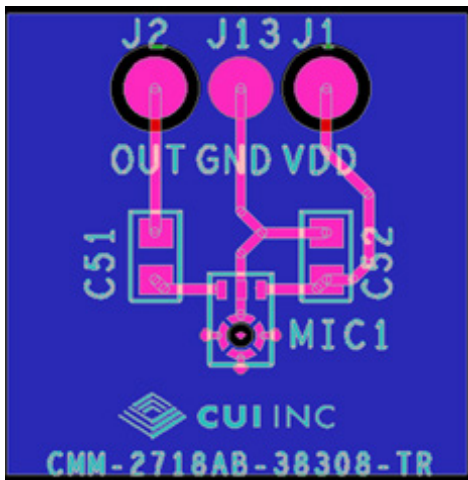
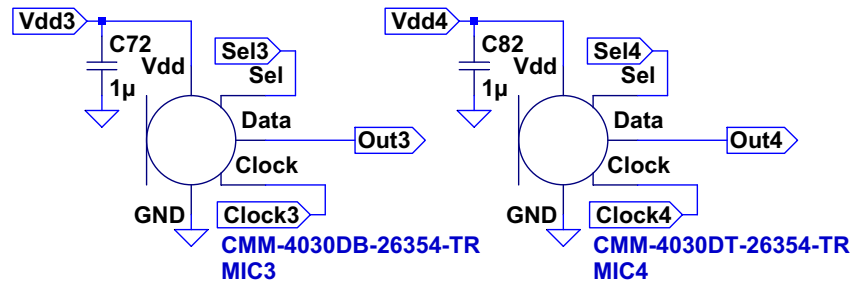
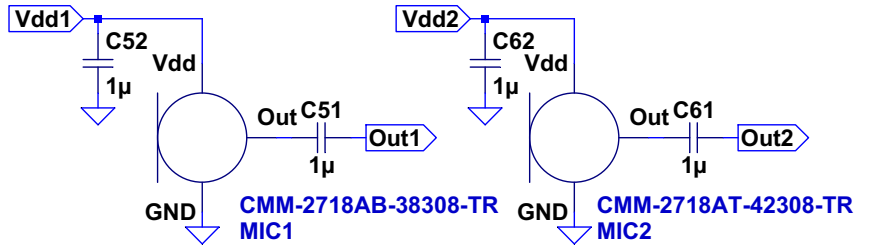
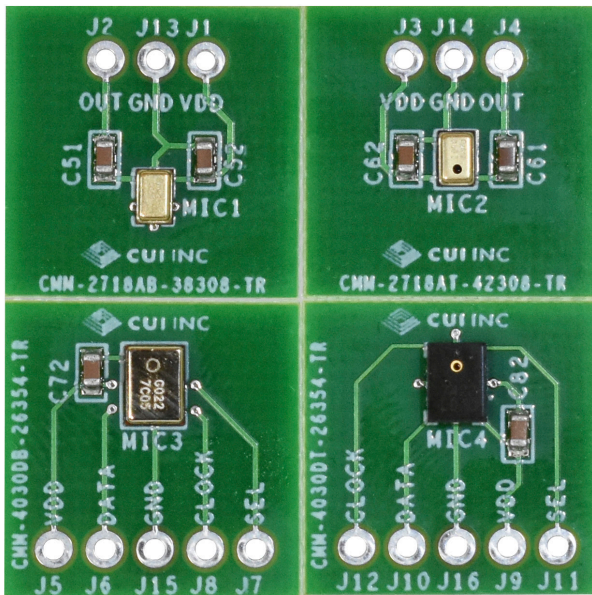

## CMM-2718AB-38308-TR

[WWW.CUIDEVICES.COM/PRODUCT/AUDIO/MICROPHONES/MEMS-MICROPHONES/CMM-2718AB-38308-TR](http://WWW.CUIDEVICES.COM/PRODUCT/AUDIO/MICROPHONES/MEMS-MICROPHONES/CMM-2718AB-38308-TR)

### ELECTRICAL

parameter	conditions/description	min	typ	max	units
directivity	omnidirectional				
sensitivity (S)	at 94 dB SPL, 1 kHz	-41	-38	-35	dB
supply voltage (V <sub>DD</sub> )		1.6	2.0	3.6	V
current consumption (I <sub>DSS</sub> )	V <sub>DD</sub> = 2.0 V		80		μA
sensitivity reduction	V <sub>DD</sub> = 3.6 ~ 1.6 V		-0.5		dB
frequency (f)		100		10,000	Hz
signal to noise ratio (S/N)	at 94 dB SPL, 1 kHz (A-weighted)		65		dB
total harmonic distortion (THD)	at 94 dB SPL, 1 kHz		0.2		%
acoustic overload point (AOP)	at 10% THD, 1 kHz		130		dB SPL
output impedance (Z <sub>out</sub> )	at 1 kHz			300	Ω

Notes: 1. All specifications measured at 23±2°C, humidity at 55±20%, unless otherwise noted.

### FREQUENCY RESPONSE CURVE

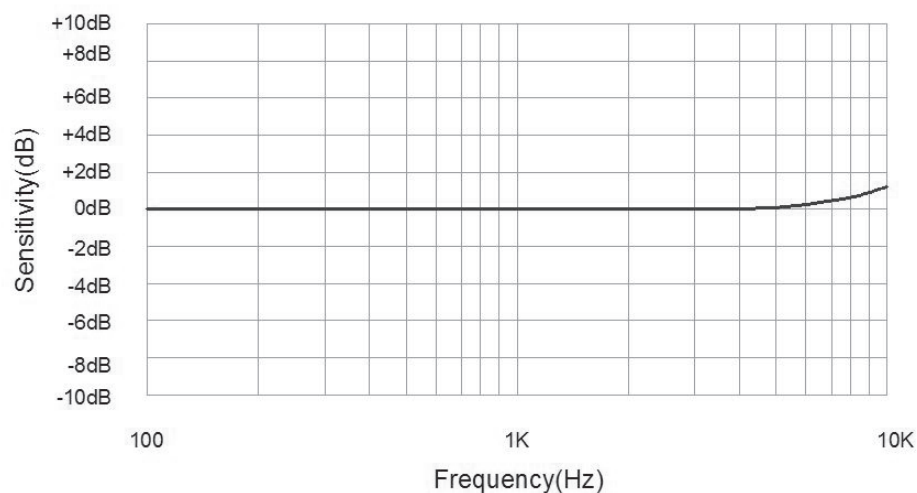

## CMM-2718AT-42308-TR

[WWW.CUIDEVICES.COM/PRODUCT/AUDIO/MICROPHONES/MEMS-MICROPHONES/CMM-2718AT-42308-TR](http://WWW.CUIDEVICES.COM/PRODUCT/AUDIO/MICROPHONES/MEMS-MICROPHONES/CMM-2718AT-42308-TR)

### ELECTRICAL

parameter	conditions/description	min	typ	max	units
directivity	omnidirectional				
sensitivity (S)	at 94 dB SPL, 1 kHz	-45	-42	-39	dB
supply voltage (V <sub>DD</sub> )		1.6	2.0	3.6	V
current consumption (I <sub>DSS</sub> )	V <sub>DD</sub> = 2.0 V		80		μA
sensitivity reduction	V <sub>DD</sub> = 3.6 ~ 1.6 V		-0.5		dB
frequency (f)		100		10,000	Hz
signal to noise ratio (S/N)	at 94 dB SPL, 1 kHz (A-weighted)		60		dBA
total harmonic distortion (THD)	at 94 dB SPL, 1 kHz		0.2		%
acoustic overload point (AOP)	at 10% THD, 1 kHz		130		dB SPL
output impedance (Z <sub>out</sub> )	at 1 kHz			300	Ω

Notes: 1. All specifications measured at 23±2°C, humidity at 55±20%, unless otherwise noted.

### FREQUENCY RESPONSE CURVE

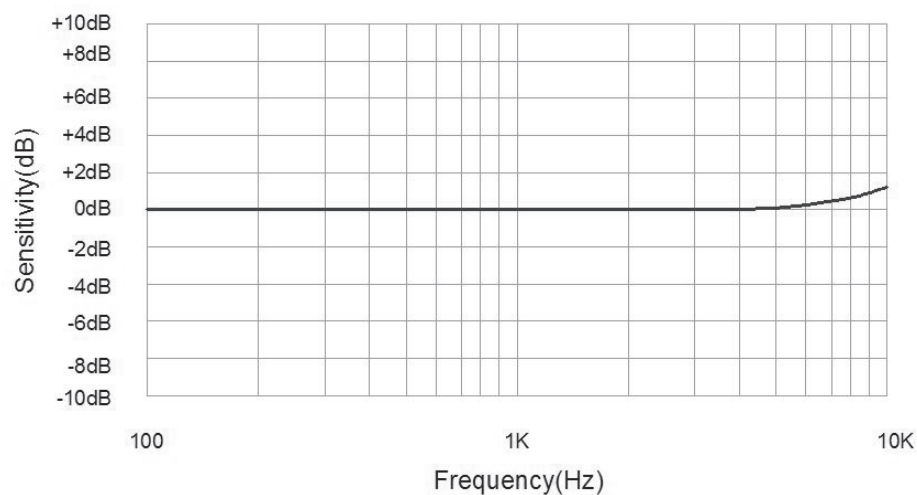

## CMM-4030DB-26354-TR

WWW.CUIDEVICES.COM/PRODUCT/AUDIO/MICROPHONES/MEMS-MICROPHONES/CMM-4030DB-26354-TR

### ELECTRICAL

parameter	conditions/description	min	typ	max	units
directivity	omnidirectional				
sensitivity (S)	at 94 dB SPL, 1 kHz	-29	-26	-23	dB FS
supply voltage (V <sub>DD</sub> )		1.6	2.0	3.6	V
current consumption (I <sub>DD</sub> )			0.54		mA
sensitivity reduction	V <sub>DD</sub> = 3.6 ~ 1.6 V		-0.5		dB FS
frequency (f)		100		10,000	Hz
signal to noise ratio (S/N)	at 94 dB SPL, 1 kHz (A-weighted)		64		dBA
total harmonic distortion (THD)	at 94 dB SPL, 1 kHz		0.2		%
acoustic overload point (AOP)	at 10% THD, 1 kHz		120		dB SPL
output impedance (Z <sub>out</sub> )	at 1 kHz			300	Ω
power supply rejection (PSR)	100 mVp-p square wave at 217 Hz (A-weighted)		-90		dB FS

### DIGITAL INTERFACE

parameter	conditions/description	min	typ	max	units
sleep current (I <sub>SLEEP</sub> )	F <sub>CLOCK</sub> < 1 kHz		3	4	μA
fall-asleep time	F <sub>CLOCK</sub> < 1 kHz			50	μs
wake-up time	F <sub>CLOCK</sub> ≥ 1 MHz			52	ms
short circuit current (I <sub>sc</sub> )	grounded data pin		1	10	mA
output load (C <sub>LOAD</sub> )				100	pF
data format	1-Bit PDM				
clock frequency (F <sub>CLOCK</sub> )		1.0	2.4	3.2	MHz
clock duty cycle (F <sub>DC</sub> )		40		60	%
clock rise time (t <sub>CR</sub> )				10	ns
clock fall time (t <sub>CF</sub> )				10	ns
logic input/output low (V <sub>IOL</sub> )	I <sub>OUT</sub> = 1 mA	-0.30		0.35xV <sub>DD</sub>	V
logic input/output high (V <sub>IOH</sub> )	I <sub>OUT</sub> = 1 mA	0.65xV <sub>DD</sub>		V <sub>DD</sub> +0.3	V
delay time for valid data (t <sub>DV</sub> )		18		60	ns
delay time for high z (t <sub>DH</sub> )		0		16	ns

Notes: 1. All specifications measured at 23±2°C, humidity at 55±20%, V<sub>DD</sub> = 2.0 V, F<sub>CLOCK</sub> = 2.4 MHz, unless otherwise noted.

### FREQUENCY RESPONSE CURVE

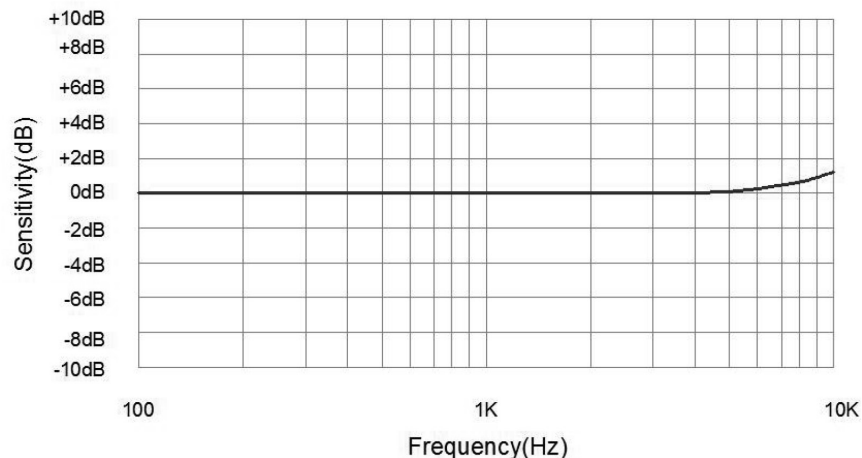

## CMM-4030DT-26354-TR

WWW.CUIDEVICES.COM/PRODUCT/AUDIO/MICROPHONES/MEMS-MICROPHONES/CMM-4030DT-26354-TR

### ELECTRICAL

parameter	conditions/description	min	typ	max	units
directivity	omnidirectional				
sensitivity (S)	at 94 dB SPL, 1 kHz	-29	-26	-23	dB FS
supply voltage (V <sub>DD</sub> )		1.6	2.0	3.6	V
current consumption (I <sub>DD</sub> )			0.54		mA
sensitivity reduction	V <sub>DD</sub> = 3.6 ~ 1.6 V		-0.5		dB FS
frequency (f)		100		10,000	Hz
signal to noise ratio (S/N)	at 94 dB SPL, 1 kHz (A-weighted)		65		dB
total harmonic distortion (THD)	at 94 dB SPL, 1 kHz		0.2		%
acoustic overload point (AOP)	at 10% THD, 1 kHz		120		dB SPL
output impedance (Z <sub>out</sub> )	at 1 kHz			300	Ω
power supply rejection (PSR)	100 mVp-p square wave at 217 Hz (A-weighted)		-90		dB FS

### DIGITAL INTERFACE

parameter	conditions/description	min	typ	max	units
sleep current (I <sub>SLEEP</sub> )	F <sub>CLOCK</sub> < 1 kHz		3	4	μA
fall-asleep time	F <sub>CLOCK</sub> < 1 kHz			50	μs
wake-up time	F <sub>CLOCK</sub> ≥ 1 MHz			52	ms
short circuit current (I <sub>sc</sub> )	grounded data pin		1	10	mA
output load (C <sub>LOAD</sub> )				100	pF
data format	1-Bit PDM				
clock frequency (F <sub>CLOCK</sub> )		1.0	2.4	3.2	MHz
clock duty cycle (F <sub>DC</sub> )		40		60	%
clock rise time (t <sub>CR</sub> )				10	ns
clock fall time (t <sub>CF</sub> )				10	ns
logic input/output low (V <sub>IOL</sub> )	I <sub>OUT</sub> = 1 mA	-0.30		0.35xV <sub>DD</sub>	V
logic input/output high (V <sub>IOH</sub> )	I <sub>OUT</sub> = 1 mA	0.65xV <sub>DD</sub>		V <sub>DD</sub> +0.3	V
delay time for valid data (t <sub>DV</sub> )		18		60	ns
delay time for high z (t <sub>DH</sub> )		0		16	ns

Notes: 1. All specifications measured at 23±2°C, humidity at 55±20%, V<sub>DD</sub> = 2.0 V, F<sub>CLOCK</sub> = 2.4 MHz, unless otherwise noted.

### FREQUENCY RESPONSE CURVE

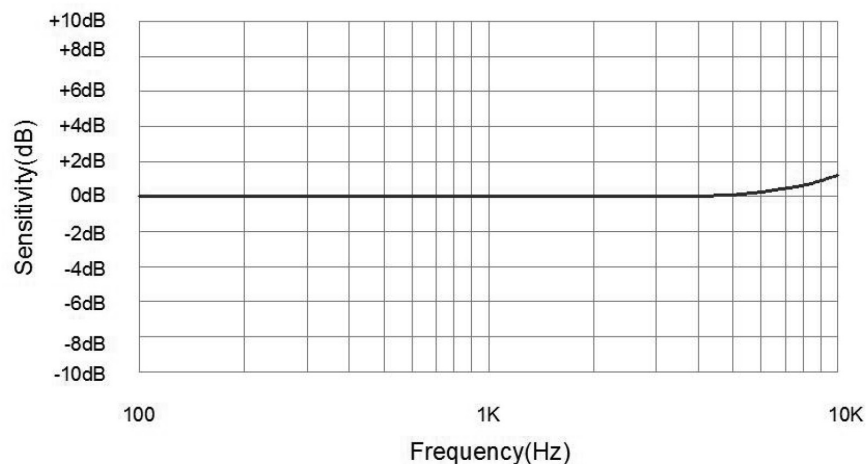

## REVISION HISTORY

---

rev.	description	date
1.0	initial release	05/14/2019
1.01	brand update	04/06/2020

The revision history provided is for informational purposes only and is believed to be accurate.

---

# CUI DEVICES

CUI Devices offers a one (1) year limited warranty. Complete warranty information is listed on our website.

CUI Devices reserves the right to make changes to the product at any time without notice. Information provided by CUI Devices is believed to be accurate and reliable. However, no responsibility is assumed by CUI Devices for its use, nor for any infringements of patents or other rights of third parties which may result from its use.

CUI Devices products are not authorized or warranted for use as critical components in equipment that requires an extremely high level of reliability. A critical component is any component of a life support device or system whose failure to perform can be reasonably expected to cause the failure of the life support device or system, or to affect its safety or effectiveness.

## X-ON Electronics

Largest Supplier of Electrical and Electronic Components

*Click to view similar products for [Audio IC Development Tools](#) category:*

*Click to view products by [CUI Devices](#) manufacturer:*

Other Similar products are found below :

[LM4906MMBD](#) [LM4935RLEVAL](#) [LME49710NABD](#) [LME49740MABD](#) [LME49740NABD](#) [LME49860MABD](#) [LME49870MABD](#) [EVAL-AD1940AZ](#) [EVAL-ADAU1401AEBZ](#) [SRC4382EVM-PDK](#) [TLV320AIC36EVM-K](#) [TPA5052EVM](#) [TPA6136A2YFFEVM](#) [LM4562HABD](#) [LM4906LDBD](#) [LM4923LQBD](#) [LM4992SDBD](#) [LME49710MABD](#) [LME49713MABD](#) [LME49860NABD](#) [MAX98300EVKIT+WLP](#) [MAX9738EVKIT+](#) [MAX98358EVSYS#WLP](#) [MAX9723DEVKIT+](#) [EVAL-ADAV803EBZ](#) [LM4809MBD](#) [LM4674TLBD](#) [CDBWM8725-M-1](#) [CDBWM8533-M-1](#) [EV\\_IC5-40740-FX](#) [SDCK3](#) [PIM524](#) [MAX9723DEVCMODU+](#) [DEV-17737](#) [MAX9850EVCMOD2#](#) [EVALAHNBIM69D130V01TOBO1](#) [1063](#) [TAS5756MDCAEVM](#) [TLV320ADC3101EVM-K](#) [TLV320AIC3007EVM-K](#) [TLV320AIC3105EVM-K](#) [TLV320AIC3253EVM-K](#) [TPA2016D2EVM](#) [TPA2035D1EVM](#) [TPA2051D3YFFEVM](#) [TPA3107D2EVM](#) [TPA6120A2EVM](#) [TPA6132A2EVM2](#) [MIKROE-2454](#) [1381](#)