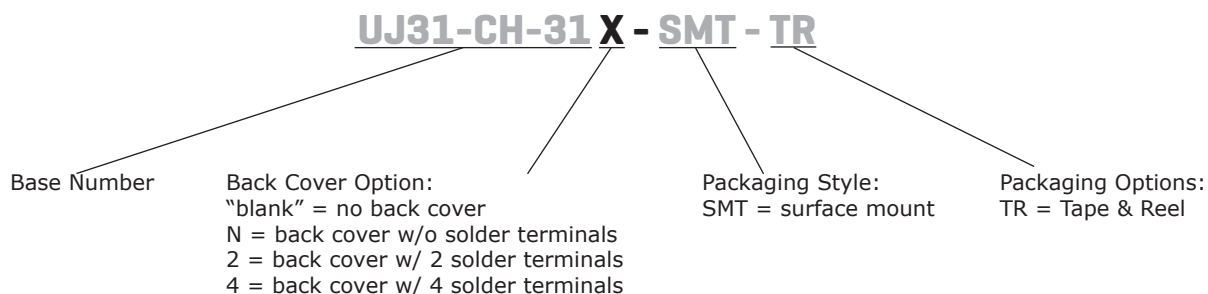

**SERIES:** UJ31-CH-SMT | **DESCRIPTION:** USB RECEPTACLE**FEATURES**

- USB Type C receptacle
- USB 3.1
- 10 Gbit/s data transfer speed
- reflow solder compatible
- tape & reel packaging

**PART NUMBER KEY****SPECIFICATIONS**

parameter	conditions/description	min	typ	max	units
rated input voltage				20	Vdc
rated input current	as per EIA-364-70, Method B				
	power pins collectively (A4, A9, B4, B9)			5.0	A
	GND pins collectively (A1, A12, B1, B12)			6.25	A
	VCONN pins individually (A5, B5)			1.25	A
	all other signal pins individually			0.25	A
contact resistance <sup>1</sup>	between terminals and mating plug			40	mΩ
insulation resistance	at 100 Vdc for 1 minute between adjacent contacts	100			MΩ
voltage withstand	at 60 Hz for 1 minute between adjacent contacts			100	Vac
insertion force	at a rate of 12.5 mm/min	5		20	N
withdrawal force	at a rate of 12.5 mm/min	8		20	N
life	at a rate of 200 max cycles per hour		10,000		cycles
operating temperature		-30		85	°C
storage temperature		-40		85	°C
flammability rating	UL94V-0				
RoHS	yes				

Note: 1. When measured at 20 mV max / 100 mA.

## MECHANICAL DRAWING

units: mm  
 tolerance:  
 X.X ±0.20 mm  
 X.XX ±0.15 mm

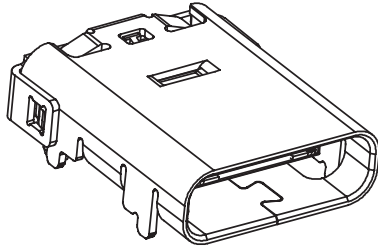

	MATERIAL	PLATING
contact terminals	copper alloy	contact: 2 μ" gold solder: tin
shell	stainless steel	nickel
EMI shell	stainless steel	
mid plate	stainless steel	tin
insulator	PA9T	

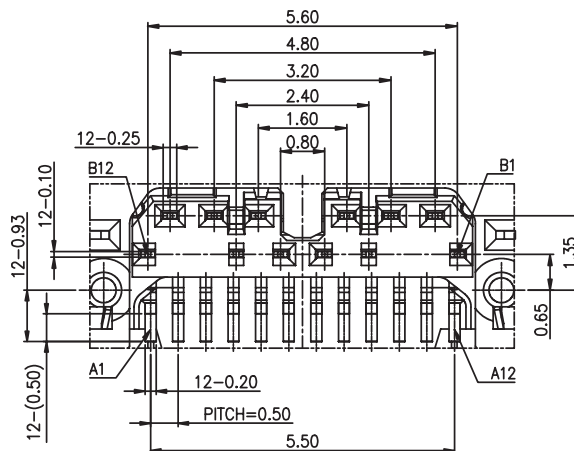
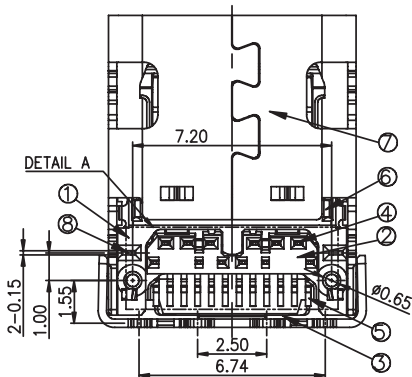
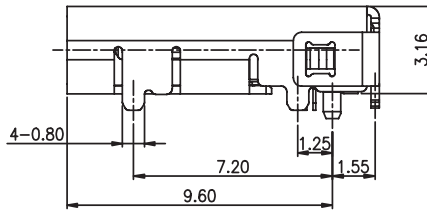
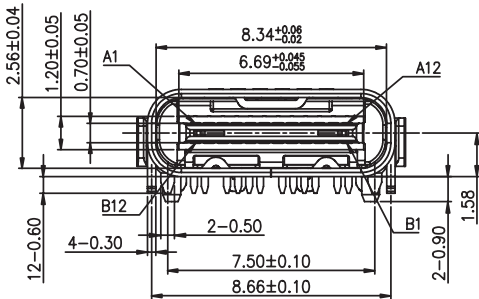
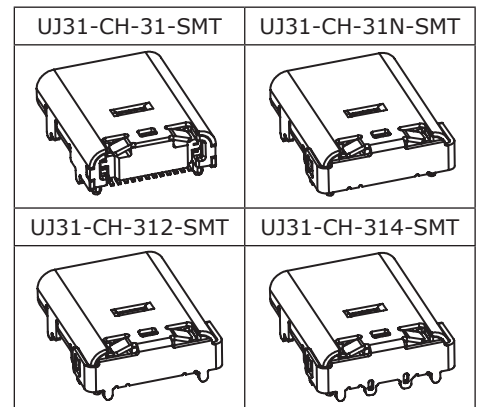
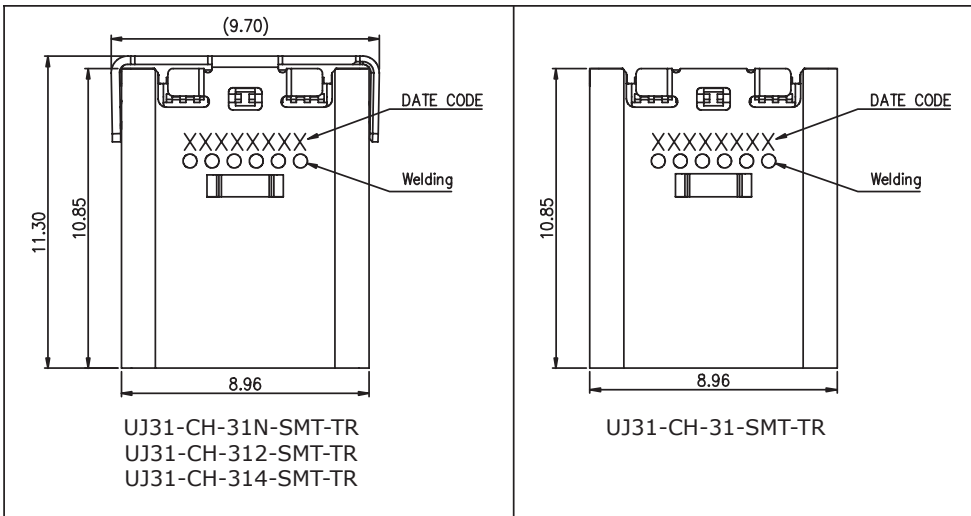

DETAIL A  
 SCALE: 8/1



## SOLDERABILITY

parameter	conditions/description	min	typ	max	units
reel storage	at relative humidity <60%			30	°C
reflow soldering <sup>1</sup>	see reflow profile	255	260	265	°C

Note: 1. It is recommended to reflow solder within 168 hours from opening vacuum packaging at a temperature <30°C & relative humidity <60%.

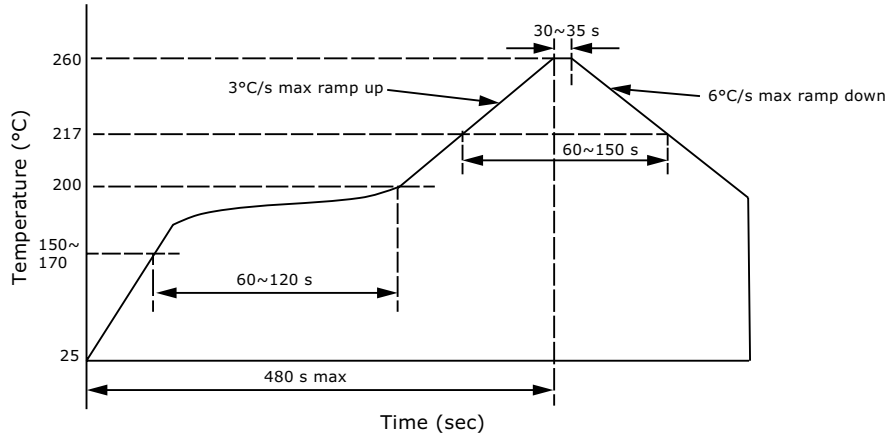

## PACKAGING

units: mm

Reel Size: Ø380 mm

Reel QTY: 1,200 pcs per reel

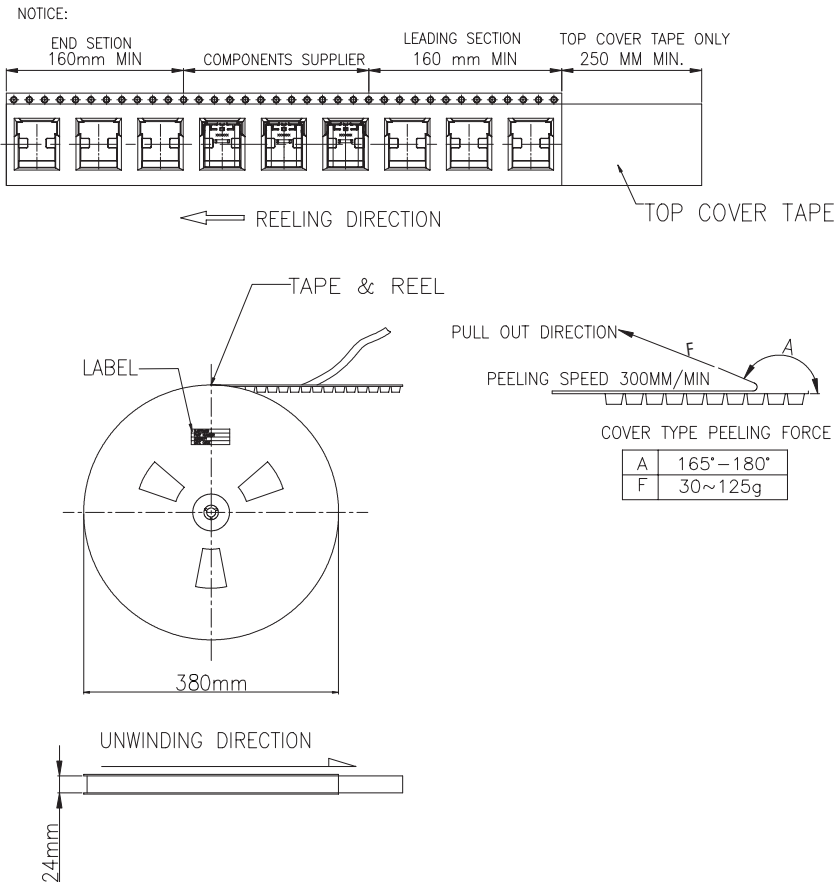
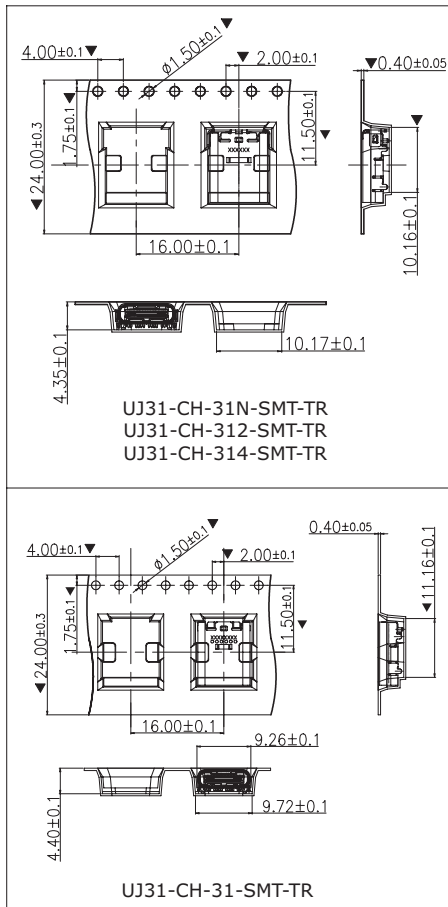

## REVISION HISTORY

---

rev.	description	date
1.0	initial release	12/19/2017
1.01	updated reel details	01/19/2018
1.02	updated datasheet	01/30/2018
1.03	brand update	01/28/2020

The revision history provided is for informational purposes only and is believed to be accurate.

---

# CUI DEVICES

CUI Devices offers a one (1) year limited warranty. Complete warranty information is listed on our website.

CUI Devices reserves the right to make changes to the product at any time without notice. Information provided by CUI Devices is believed to be accurate and reliable. However, no responsibility is assumed by CUI Devices for its use, nor for any infringements of patents or other rights of third parties which may result from its use.

CUI Devices products are not authorized or warranted for use as critical components in equipment that requires an extremely high level of reliability. A critical component is any component of a life support device or system whose failure to perform can be reasonably expected to cause the failure of the life support device or system, or to affect its safety or effectiveness.

## X-ON Electronics

Largest Supplier of Electrical and Electronic Components

*Click to view similar products for [USB Connectors](#) category:*

*Click to view products by [CUI Devices](#) manufacturer:*

Other Similar products are found below :

[65-647-8-BK-BU](#) [950](#) [952](#) [E8144-B01021-L](#) [A-USB B-TOP-C](#) [MUSBA511N5](#) [MUSBD11135](#) [217450-1](#) [KMBVX-TH-5S-B30](#) [896-30-004-00-000000](#) [KUSBVX-BS1N-W30](#) [KUSBX-AP-KIT-SCBLK](#) [KUSBX-AS2N-W](#) [KUSBX-SMT2AP1S-W](#) [KUSBX-SMT2AP1S-W30](#) [935](#) [957](#) [30-498-6](#) [SK-60A-2](#) [17-210051](#) [1734082-1](#) [30-1574](#) [30-470](#) [30-489](#) [30-541](#) [30-572-3](#) [A-USB A-2P-C](#) [MIKROE-1451](#) [USBFTV2PEM2G](#) [USBFTVC6ZN](#) [KUSBX-AS2N-W30](#) [KUSBX-SLAS1N-W](#) [KUSBX-SMT-AS1N-W30](#) [4689-1](#) [1-1734084-2](#) [E8110-001-01](#) [33UBARS1-04SW11](#) [33UBAR-04SW11](#) [USBF21ZNSCC](#) [USBBFTV6ZC](#) [10135326-001LF](#) [M9177/3-1](#) [USB-A-S-F-B-VT](#) [925](#) [4198](#) [690-024-633-031](#) [KUSBEX-BSFS1N-W](#) [USBFTVC6MRG](#) [UA-20BMFA-SL8001](#) [17-250101](#)