

MODEL: UJC-VP-3-SMT-TR | **DESCRIPTION:** USB RECEPTACLE**FEATURES**

- USB Type C receptacle
- mates with standard USB Type C plugs
- designed for power only applications
- vertical mount
- 6-pin
- reflow solder compatible
- tape & reel packaging

**SPECIFICATIONS**

parameter	conditions/description	min	typ	max	units
rated input voltage				20	Vdc
rated input current	Vbus/GND pins (A9, A12, B9, B12) CC pins (A5, B5)			3 1.25	A A
contact resistance ¹				40	mΩ
insulation resistance	at 100 Vdc for 1 minute between adjacent contacts	100			MΩ
voltage withstand	for 1 minute between adjacent contacts			100	Vac
insertion force	at a rate of 12.5 mm/min	5		20	N
withdrawal force	at a rate of 12.5 mm/min	8		20	N
life	at a rate of 180 cycles/hour		10,000		cycles
operating temperature		-25		85	°C
storage temperature		-20		60	°C
flammability rating	UL94V-0				
RoHS	yes				

Note: 1. When measured at 20 mV / 100 mA max.

SOLDERABILITY

parameter	conditions/description	min	typ	max	units
reel storage	at relative humidity <60%			30	°C
reflow soldering ²	see reflow profile			260	°C

Note: 2. It is recommended to reflow solder within 168 hours from opening vacuum packaging at a temperature <30°C & relative humidity <60%.

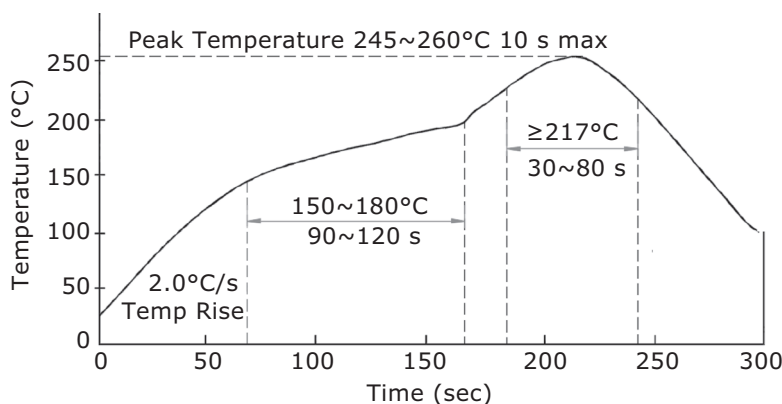

MECHANICAL DRAWING

units: mm
 tolerance:
 X.±0.50 mm
 X.X ±0.30 mm
 X.XX ±0.20 mm
 X.XXX ±0.10 mm
 PCB: ±0.05 mm
 PCB thickness: 1~1.2 mm

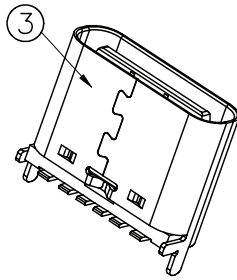

	MATERIAL	PLATING
1 insulator	LCP (UL94V-0)	black
2 contact	copper alloy	gold over nickel
3 shell	stainless steel	nickel
4 shielding plate	stainless steel	contact area: gold flash over nickel solder area: matte tin over nickel
5 cover	LCP (UL94V-0)	black

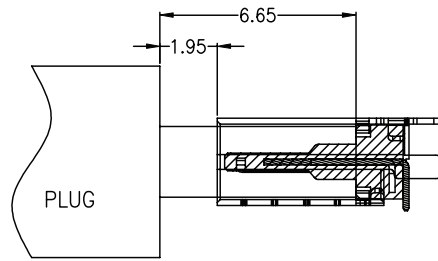
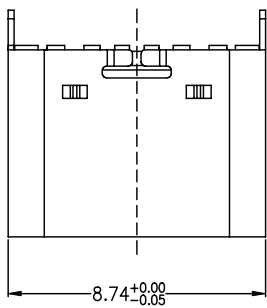

Plug and Receptacle Mating View

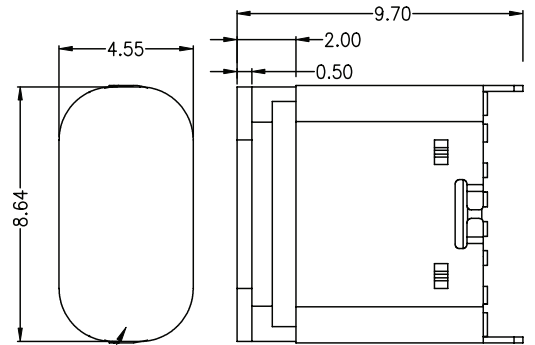

Cap information

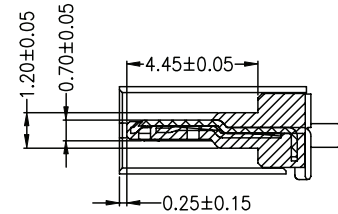
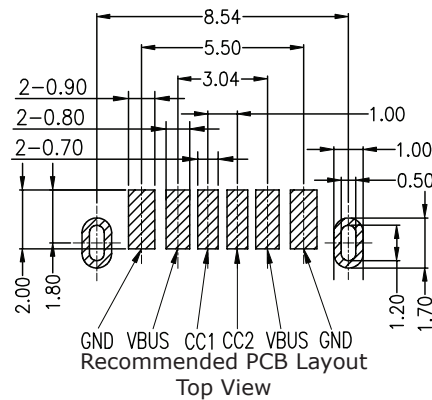
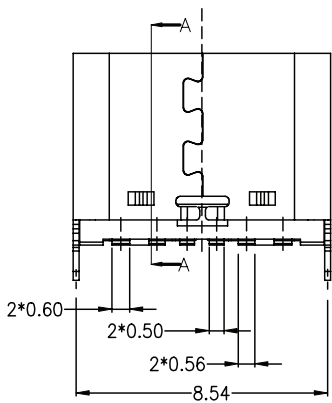
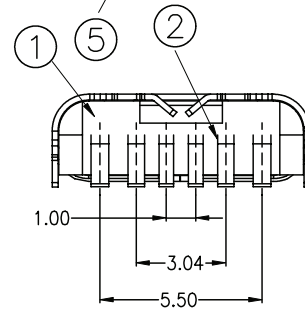
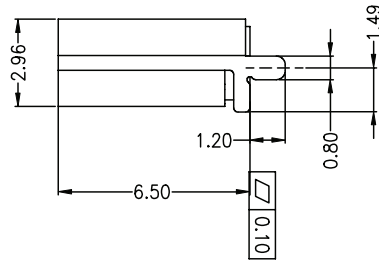
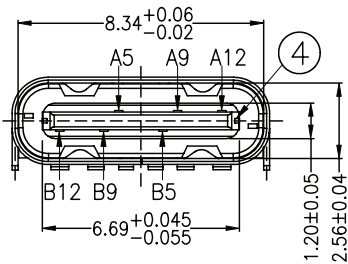

PIN CONNECTIONS			
PIN	SIGNAL NAME	PIN	SIGNAL NAME
A5	CC1	B12	GND
A9	VBUS	B9	VBUS
A12	GND	B5	CC2

PACKAGING

units: mm

Reel Size: Ø330 mm

Reel QTY: 600 pcs per reel

Carton QTY: 6,000 pcs per carton

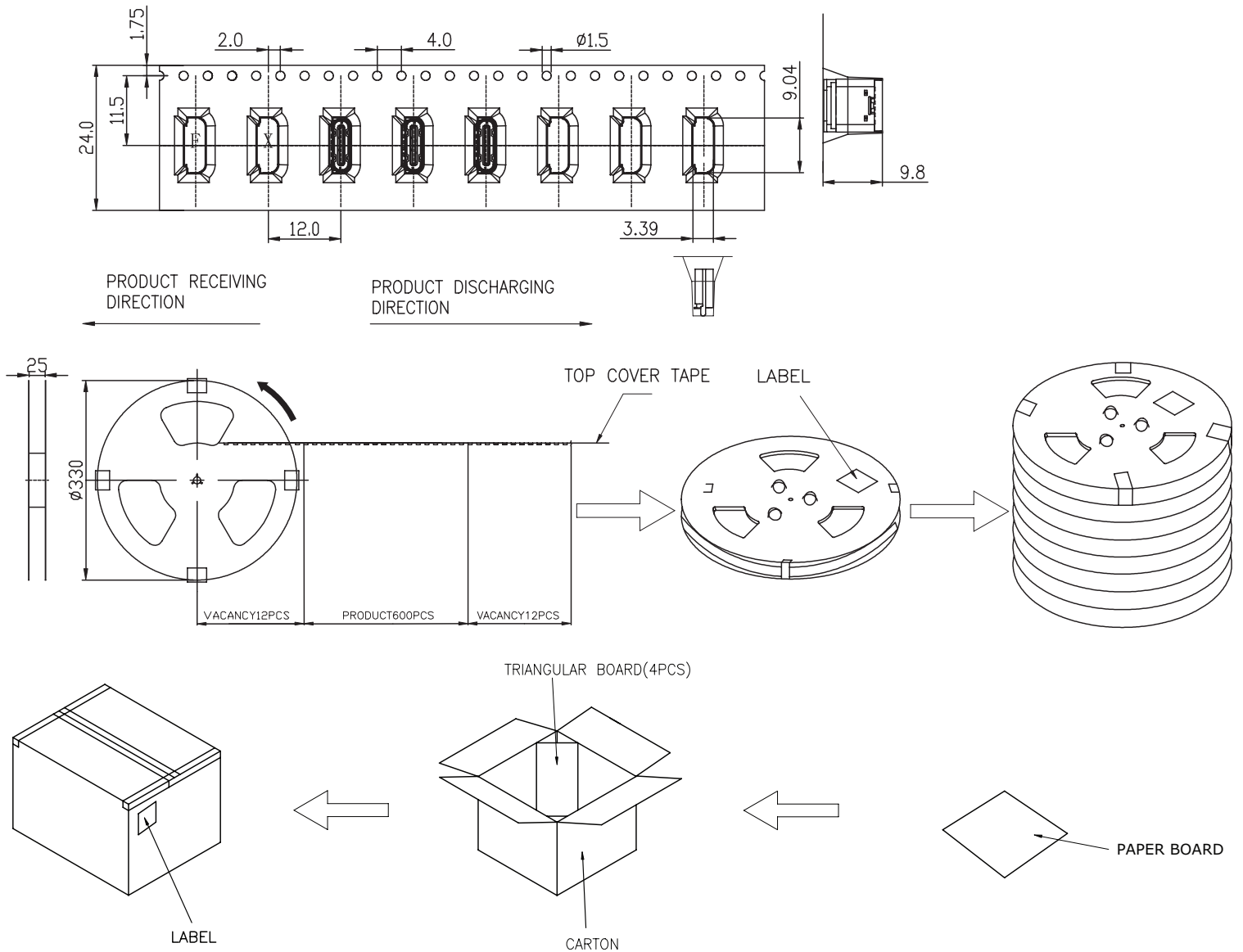

REVISION HISTORY

rev.	description	date
1.0	initial release	05/11/2021

The revision history provided is for informational purposes only and is believed to be accurate.

CUI DEVICES

CUI Devices offers a one (1) year limited warranty. Complete warranty information is listed on our website.

CUI Devices reserves the right to make changes to the product at any time without notice. Information provided by CUI Devices is believed to be accurate and reliable. However, no responsibility is assumed by CUI Devices for its use, nor for any infringements of patents or other rights of third parties which may result from its use.

CUI Devices products are not authorized or warranted for use as critical components in equipment that requires an extremely high level of reliability. A critical component is any component of a life support device or system whose failure to perform can be reasonably expected to cause the failure of the life support device or system, or to affect its safety or effectiveness.

X-ON Electronics

Largest Supplier of Electrical and Electronic Components

Click to view similar products for [USB Connectors](#) category:

Click to view products by [CUI Devices](#) manufacturer:

Other Similar products are found below :

[950](#) [A-USB A-LP-SMT-C](#) [A-USB B-TOP-C](#) [MUSBA511N5](#) [MUSBC111M5](#) [MUSBD11135](#) [17-200721](#) [217450-1](#) [KMBVX-TH-5S-B30](#)
[896-30-004-00-000000](#) [KUSBX-AS2N-W](#) [KUSBX-SMT2AP1S-W30](#) [935](#) [957](#) [30-498-6](#) [SK-60A-2](#) [1734082-1](#) [CIR08F-20](#) [30-1574](#) [30-470](#)
[30-489](#) [30-541](#) [MAB 5 S](#) [A-USB A-2P-C](#) [MIKROE-1451](#) [USBFTV2PEM2G](#) [USBFTVSCCG](#) [4689-1](#) [1-1734084-2](#) [MUSBA81130](#)
[MUSBC11135](#) [CIR08F-20-27P-F80-VO](#) [USBF21ZNSCC](#) [USBBFTV6ZC](#) [MUSBB151341](#) [10135326-001LF](#) [M9177/3-1](#) [USB-A-S-F-B-VT](#)
[4198](#) [1310-1018-05](#) [690-024-633-031](#) [UB-20PMFP-LC7001](#) [USBFTVC6MRG](#) [UA-20BMFA-SL8001](#) [17-200011](#) [USBFTVC7ZC](#) [UB-](#)
[20AFMM-LL7A01](#) [USBFTVC2MN](#) [CAP-WCCMLPB1](#) [CAP-WCCMLPC1](#)