



**SERIES: VHK100W | DESCRIPTION: DC-DC CONVERTER**
**FEATURES**

- up to 100 W isolated output
- rugged metal enclosure with integrated heat sink
- 4:1 input range (9~36 Vdc, 18~75 Vdc)
- single output from 3.3~48 Vdc
- 1,500 Vdc isolation
- over current, over temperature, over voltage, and short circuit protections
- remote on/off
- efficiency up to 87%

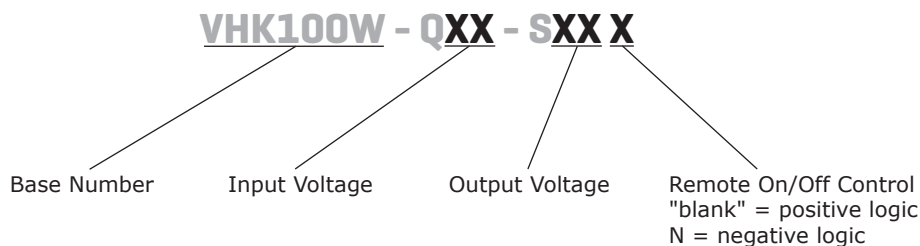

MODEL	input voltage	output voltage	output current	output power	ripple and noise <sup>1</sup>	efficiency
	range (Vdc)	(Vdc)	max (A)	max (W)	max (mVp-p)	typ (%)
VHK100W-Q24-S3R3	9 ~ 36	3.3	20	66	100	80
VHK100W-Q24-S5	9 ~ 36	5	20	100	100	82
VHK100W-Q24-S12	9 ~ 36	12	8.3	100	150	84
VHK100W-Q24-S15	9 ~ 36	15	6.7	100	150	85.5
VHK100W-Q24-S24	9 ~ 36	24	4.17	100	240	85
VHK100W-Q24-S28	9 ~ 36	28	3.57	100	280	86
VHK100W-Q24-S48	9 ~ 36	48	2.08	100	480	84
VHK100W-Q48-S3R3	18 ~ 75	3.3	20	66	100	79
VHK100W-Q48-S5	18 ~ 75	5	20	100	100	84.5
VHK100W-Q48-S12	18 ~ 75	12	8.3	100	150	85.5
VHK100W-Q48-S15	18 ~ 75	15	6.7	100	150	86.5
VHK100W-Q48-S24	18 ~ 75	24	4.17	100	240	87
VHK100W-Q48-S28	18 ~ 75	28	3.57	100	280	86
VHK100W-Q48-S48	18 ~ 75	48	2.08	100	480	85

Note: 1. Ripple and noise are measured at full load, 20 MHz BW with 10µF tantalum capacitor and 1µF ceramic capacitor across output. The 48 Vdc output models only require the 1µF ceramic capacitor across the output.

**PART NUMBER KEY**

## INPUT

parameter	conditions/description	min	typ	max	units
operating input voltage	24 Vdc input models	9	24	36	Vdc
	48 Vdc input models	18	48	75	Vdc
under voltage shutdown	24 Vdc input		8.8		Vdc
	power up power down		8		Vdc
	48 Vdc input		17		Vdc
	power up power down		16		Vdc
CTRL <sup>1</sup>	positive logic	models ON (>3.5 Vdc or open circuit)			
		models OFF (0~1.8 Vdc)			
	negative logic	models ON (0~1.8 Vdc)			
		models OFF (>3.5 Vdc or open circuit)			
filter	pi filter				
input fuse	20A time delay fuse for 24 Vin models, 10A time delay fuse for 48 Vin models				

Note: 1. Open collector refer to -Vin

## OUTPUT

parameter	conditions/description	min	typ	max	units
maximum capacitive load	3.3 and 5 V output models			20,000	μF
	12 V output models			8,300	μF
	15 V output models			6,700	μF
	24 & 28 V output models			2,200	μF
	48 V output models	47		470	μF
line regulation <sup>2</sup>	measured from high line to low line			±0.2	%
load regulation <sup>2</sup>	measured from full load to zero load			±0.2	%
voltage accuracy <sup>2</sup>				±1.5	%
adjustability				±10	%
switching frequency				250	kHz
transient response	25% step load change			500	μs
temperature coefficient				±0.03	%/°C

Note: 2. A 47 μF aluminum capacitor is required on the output for 48 Vdc output models.

## PROTECTIONS

parameter	conditions/description	min	typ	max	units
short circuit protection	continuous				
over current protection	% nominal output current	110		140	%
over voltage protection		115		140	%
over temperature protection	shutdown		105		°C

## SAFETY AND COMPLIANCE

parameter	conditions/description	min	typ	max	units
isolation voltage	for 1 minute: input to output; input to case; output to case	1,500			Vdc
isolation resistance		10			MΩ
RoHS	2011/65/EU (CE)				

## ENVIRONMENTAL

parameter	conditions/description	min	typ	max	units
operating temperature	see derating curve	-40		85	°C
storage temperature		-55		105	°C

## MECHANICAL

parameter	conditions/description	min	typ	max	units
dimensions	4.23 x 4.01 x 1.50 (107.5 x 101.76 x 38.0 mm)				inch
case material	steel and aluminum extrusion				
weight			502		g

## MECHANICAL DRAWING

units: inch[mm]

tolerance: X.XX = ±0.02[±0.5]  
 X.XXX = ±0.010[±0.25]

wire range: 22~12 AWG

screw size: #6-32

PIN CONNECTIONS	
PIN	FUNCTION
1	-Vo
2	-S
3	trim
4	+S
5	+Vo
6	case
7	on/off
8	-Vin
9	+Vin

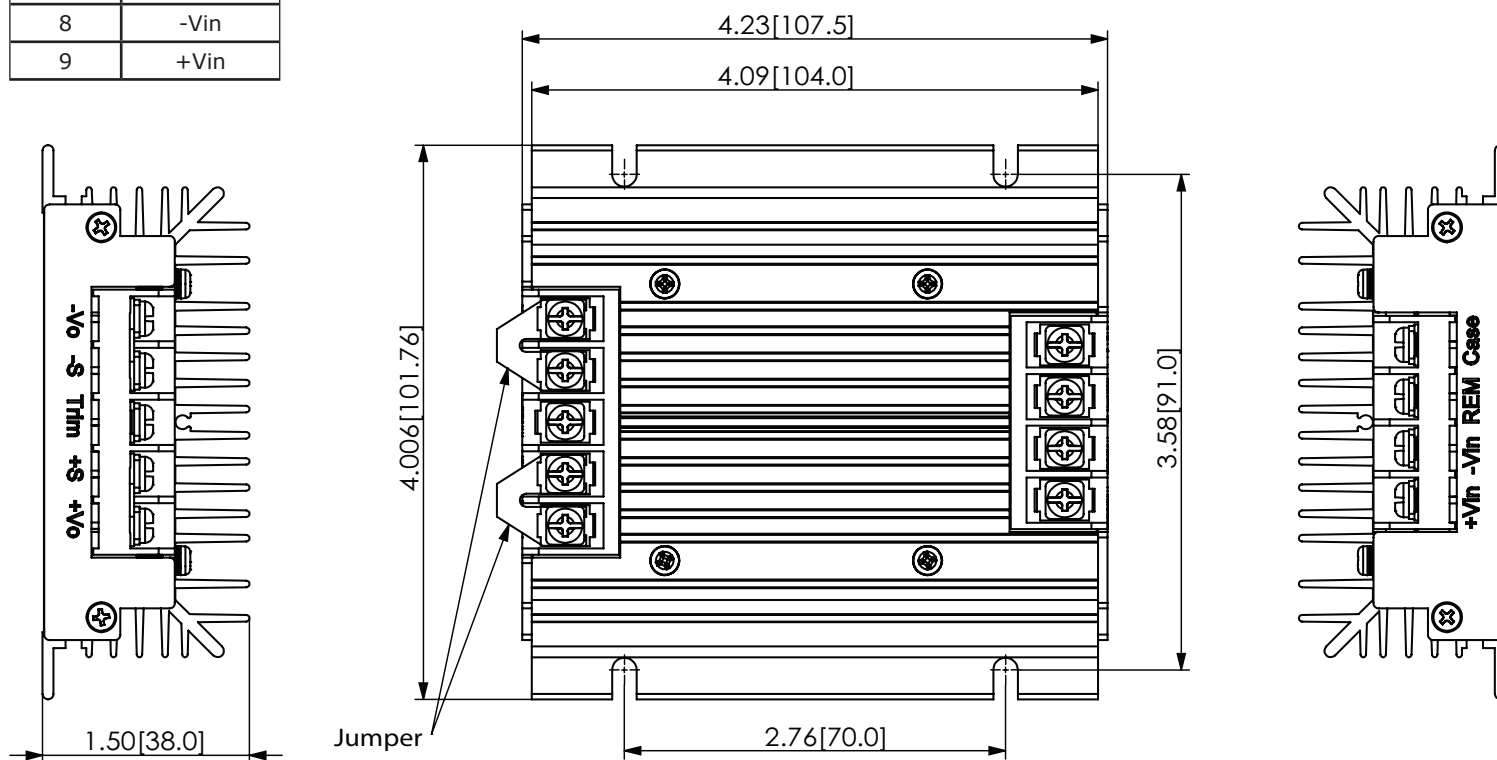
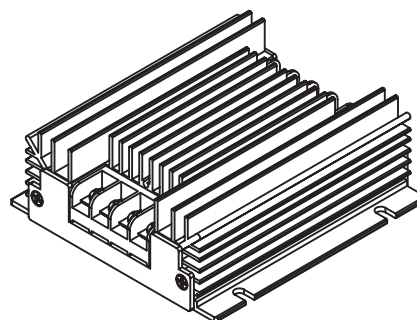

## DERATING CURVES

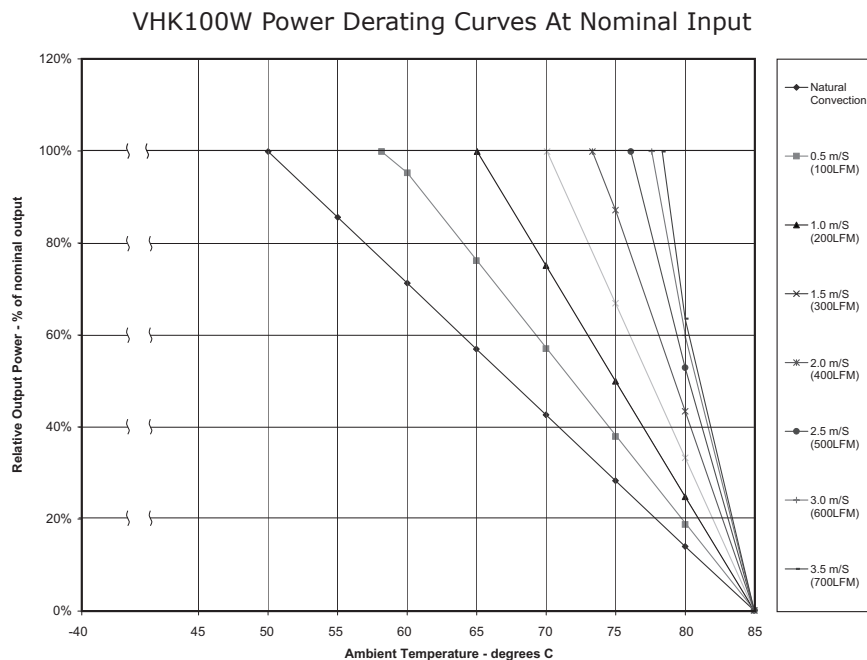

## TEST CONFIGURATION

**Figure 1**

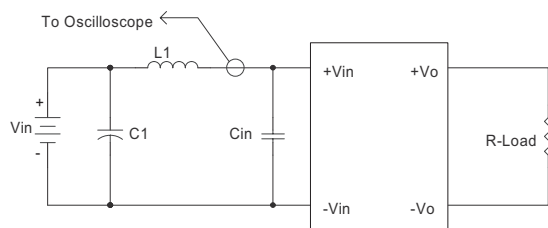

**Table 1**

External components	
L1	12μH
C1	220μF, ESR < 0.1Ω at 100 KHz
Cin	33μF, ESR < 0.7Ω at 100 KHz

Note: Input reflected-ripple current is measured with an inductor L1 and Capacitor C1 to simulate source impedance.

## EMC RECOMMENDED CIRCUITS

### EN55022 CLASS A

**Figure 2**  
Recommended Circuit for EN55022 Class A  
(for all models)

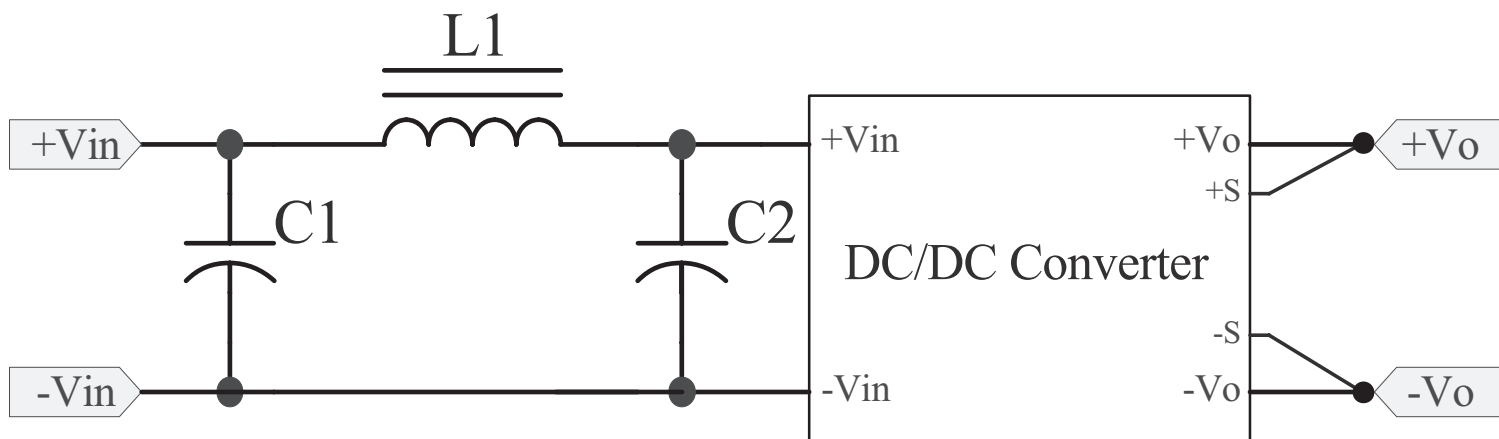

## EMC RECOMMENDED CIRCUITS (CONTINUED)

### EN55022 CLASS A

**Table 2**  
Class A Recommended Components

Model	C1 <sup>1</sup>	C2 <sup>1</sup>	L1
VHK100W-Q24-S3R3	47 μF/50 V	47 μF/50 V	3.4 μH
VHK100W-Q24-S5	47 μF/50 V	47 μF/50 V	3.4 μH
VHK100W-Q24-S12	47 μF/50 V	47 μF/50 V	3.4 μH
VHK100W-Q24-S15	47 μF/50 V	47 μF/50 V	3.4 μH
VHK100W-Q24-S24	47 μF/50 V	47 μF/50 V	3.4 μH
VHK100W-Q24-S28	47 μF/50 V	47 μF/50 V	3.4 μH
VHK100W-Q24-S48	47 μF/50 V	47 μF/50 V	3.4 μH
VHK100W-Q48-S3R3	47 μF/100 V	47 μF/100 V	3.4 μH
VHK100W-Q48-S5	47 μF/100 V	47 μF/100 V	3.4 μH
VHK100W-Q48-S12	47 μF/100 V	47 μF/100 V	3.4 μH
VHK100W-Q48-S15	47 μF/100 V	47 μF/100 V	3.4 μH
VHK100W-Q48-S24	47 μF/100 V	47 μF/100 V	3.4 μH
VHK100W-Q48-S28	47 μF/100 V	47 μF/100 V	3.4 μH
VHK100W-Q48-S48	47 μF/100 V	47 μF/100 V	3.4 μH

Note: 1. Aluminum capacitors

### EN55022 CLASS B

**Figure 3**  
Recommended Circuit for EN55022 Class B  
(for all 3.3, 5, 12, 15, 24, & 28 Vdc output models)

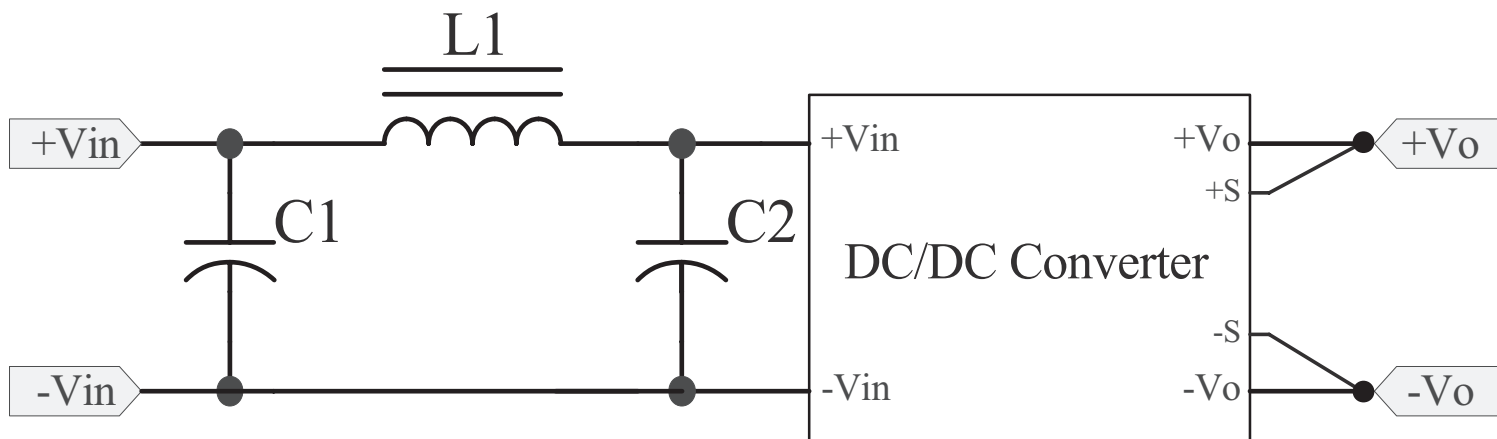

## EMC RECOMMENDED CIRCUITS (CONTINUED)

### EN55022 CLASS B

**Figure 4**  
**Recommended Circuit for EN55022 Class B**  
 (for all 48 Vdc output models)

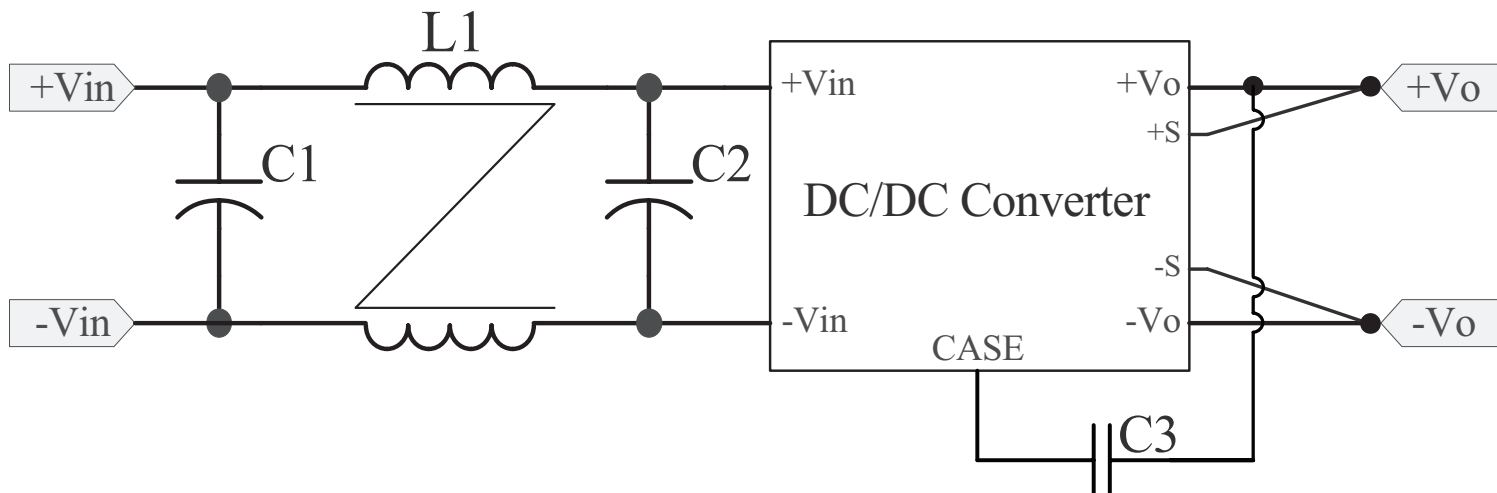

**Table 3**  
**Class B Recommended Components**

Model	C1 <sup>1</sup>	C2 <sup>1</sup>	C3 <sup>2</sup>	L1
VHK100W-Q24-S3R3	220 µF/50 V	220 µF/50 V	NC	3.4 µH
VHK100W-Q24-S5	220 µF/50 V	220 µF/50 V	NC	3.4 µH
VHK100W-Q24-S12	220 µF/50 V	220 µF/50 V	NC	3.4 µH
VHK100W-Q24-S15	220 µF/50 V	220 µF/50 V	NC	3.4 µH
VHK100W-Q24-S24	220 µF/50 V	220 µF/50 V	NC	3.4 µH
VHK100W-Q24-S28	220 µF/50 V	220 µF/50 V	NC	3.4 µH
VHK100W-Q24-S48	100 µF/50 V	100 µF/50 V	2200 pF/2 KV	0.53 mH
VHK100W-Q48-S3R3	47 µF/100 V	47 µF/100 V	NC	3.4 µH
VHK100W-Q48-S5	47 µF/100 V	47 µF/100 V	NC	3.4 µH
VHK100W-Q48-S12	47 µF/100 V	47 µF/100 V	NC	3.4 µH
VHK100W-Q48-S15	47 µF/100 V	47 µF/100 V	NC	3.4 µH
VHK100W-Q48-S24	47 µF/100 V	47 µF/100 V	NC	3.4 µH
VHK100W-Q48-S28	47 µF/100 V	47 µF/100 V	NC	3.4 µH
VHK100W-Q48-S48	47 µF/100 V	47 µF/100 V	2200 pF/2 KV	0.53 mH

Note: 1. Aluminum capacitors  
 2. Ceramic capacitors

## APPLICATION NOTES

### 1. Output Voltage Trimming

Leave open if not used.

**Figure 5**

Application Circuit for Trim pin

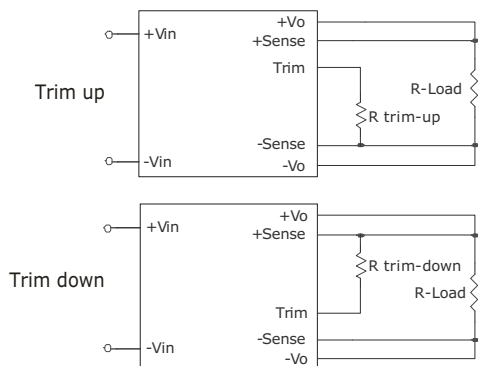

### Formula for Trim Resistor

$$R_{trim - up} = \left( \frac{R_1(V_r - V_f \left( \frac{R_2}{R_2 + R_3} \right))}{V_o - V_{o, nom}} \right) - \frac{R_2 R_3}{R_2 + R_3} (K\Omega)$$

$$R_{trim - down} = \frac{R_1(V_o - V_r)}{V_{o, nom} - V_o} - R_2 (K\Omega)$$

Note:  $R_{trim-up}$  is the external resistor in  $K\Omega$   
 $R_{trim-down}$  is the external resistor in  $K\Omega$   
 $V_{o, nom}$  is the nominal output voltage  
 $V_o$  is the desired output voltage  
 $R_1, R_2, R_3,$  and  $V_r$  are internal (see Table 4).

**Table 4**

Vout (Vdc)	R1 (KΩ)	R2 (KΩ)	R3 (KΩ)	Vr (V)	Vf (V)
3.3	3	12	4.3	1.24	0.46
5	2.32	3.3	0	2.5	0
12	9.1	51	5.1	2.5	0.46
15	12	56	8.25	2.5	0.46
24	20	100	7.5	2.5	0.46
28	23.7	150	6.2	2.5	0.53
48	36	270	5.1	2.5	0.46

Note: 1. All specifications are measured at  $T_a=25^\circ C$ , nominal input voltage and full output load unless otherwise specified.

## REVISION HISTORY

---

rev.	description	date
1.0	initial release	10/11/2006
1.01	new template applied	12/21/2011
1.02	misc. updates and corrections	03/13/2012
1.03	updated mechanical drawing	03/27/2012
1.04	V-Infinity branding removed	06/27/2012
1.05	updated spec	03/14/2013
1.06	added trimming and EMI information	12/16/2013

The revision history provided is for informational purposes only and is believed to be accurate.

**CUI INC**<sup>®</sup>

**Headquarters**  
20050 SW 112th Ave.  
Tualatin, OR 97062  
**800.275.4899**

Fax 503.612.2383  
**cui.com**  
techsupport@cui.com

CUI offers a two (2) year limited warranty. Complete warranty information is listed on our website.

CUI reserves the right to make changes to the product at any time without notice. Information provided by CUI is believed to be accurate and reliable. However, no responsibility is assumed by CUI for its use, nor for any infringements of patents or other rights of third parties which may result from its use.

CUI products are not authorized or warranted for use as critical components in equipment that requires an extremely high level of reliability. A critical component is any component of a life support device or system whose failure to perform can be reasonably expected to cause the failure of the life support device or system, or to affect its safety or effectiveness.



## X-ON Electronics

Largest Supplier of Electrical and Electronic Components

*Click to view similar products for [Isolated DC/DC Converters](#) category:*

*Click to view products by [CUI Inc](#) manufacturer:*

Other Similar products are found below :

[ESM6D044440C05AAQ](#) [FMD15.24G](#) [PSL486-7LR](#) [PSR152.5-7IR](#) [Q48T30020-NBB0](#) [AVO240-48S12B-6L](#) [AVO250-48S28B-6L](#) [NAN-0505](#) [HW-L16D](#) [JAHW100Y1](#) [217-1617-001](#) [22827](#) [SPB05C-12](#) [SQ24S15033-PS0S](#) [18952](#) [19-130041](#) [CE-1003](#) [CE-1004](#) [GQ2541-7R](#) [PSE1000DCDC-12V](#) [RDS180245](#) [MAU228](#) [419-2065-201](#) [449-2075-101](#) [TME 0303S](#) [TME 0505S](#) [TME 1205S](#) [TME 1212S](#) [TME 2405S](#) [TME 2412S](#) [J80-0041NL](#) [V300C24C150BG](#) [419-2062-200](#) [419-2063-401](#) [419-2067-101](#) [419-2067-501](#) [419-2068-001](#) [DCG40-5G](#) [DFC15U48D15](#) [449-2067-000](#) [XGS-0512](#) [XGS-1205](#) [XGS-1212](#) [XGS-2412](#) [XGS-2415](#) [XKS-1215](#) [033456](#) [NCT1000N040R050B](#) [SPB05B-15](#) [SPB05C-15](#)