



承认书

SPECIFICATION FOR APPROVAL

| | | | |
|---------------|-----------------|--------------|---|
| CUSTOMER: | | | |
| CUSTOMER P/N: | | | |
| Cybermax P/N: | CMCW1608F4R7KTT | | |
| DRAWN NO. : | CM18102703 | | |
| DATE: | 18.10.27 | REVISION NO. | A |

Signature:

| APPROVED BY | CHECKED BY | DRAWN BY |
|---|---|---|
|  |  |  |



| | | | |
|---------------|-----------------|-----------|----------|
| CUSTOMER: | | PAGE: | 1/10 |
| CUSTOMER P/N: | | REVISION: | |
| Cybermax P/N: | CMCW1608F4R7KTT | DATE: | 18.10.27 |
| DRAWN NO.: | CM18102703 | | |

| | |
|--|--|
| SHAPE & DIMENSION (UNIT:mm) | |
| | |
| Marking Code: | Size: Color: typeface: |
| PAD LAYOUT(MM): | ELECREICAL SCHEMATIC: |
| | |

| ELECREICAL SPECIFICATION | | | | | | |
|-----------------------------|-------|---------------|------------|-----|-------------|--------------------------------|
| MEAS. ITEM | SPEC. | | | | TEST FREQ. | CONDITIONS |
| L | 4.7 | μH | \pm | 10% | 7.9MHz/0.1V | Ta=25°C, Idc=0A |
| DCR | 970 | m Ω | 30%. | | | Ta=25°C |
| Isat | 0.40 | A | TYP | | 100KHz/1V | $\Delta L/L \leq 30\%$ |
| Irms | 0.42 | A | TYP | | 100KHz/1V | $\Delta \leq 40^\circ\text{C}$ |
| GENERAL SPECIFICATION | | | | | | |
| Electrical specifications : | | | at 25°C | | | |
| Operation Temperature: | | | -40~+125°C | | | |
| Storage Temperature: | | | -40~+125°C | | | |
| (1)WIRE TYPE: ϕ 0.05mm | | | | | | |
| (2)WINDING: 32.5Ts(Ref.) | | | | | | |

| | | | |
|---------------|-----------------|-----------|-----------------|
| CUSTOMER: | | PAGE: | 2/10 |
| CUSTOMER P/N: | | REVISION: | |
| Cybermax P/N: | CMCW1608F4R7KTT | DATE: | 18.10.27 |
| DRAWN NO.: | CM18102703 | | |

产品试验项目列表

| 测试项目 | 测试条件 | 标准 |
|-----------------|--|---|
| 1. 过IR ReFlow试验 | 峰值温度: 260°C, 时间: 10秒 过热风炉2次 | 验证产品过IR炉后外观状况及特性变化; 试验前后感值变化率均在10%范围内, OK。 |
| 2. 恒温恒湿试验 | 温度: 40°C ± 2°C 湿度: 95% ± 2%RH 时间: 100小时, 取出后在常温下放置1小时至不超过2小时再检查外观及特性 | 1. 试验前后感值变化率均在10%范围内, OK; 2. 制品试验后外观均无发现破裂不良, 上锡面无氧化现象。 |
| 3. 冷热冲击试验 | 冷冲击-40°C ± 2°C、热冲击125°C ± 2°C 100个循环 (冷冲击30分钟, 热冲击30分钟为一个循环) | 验证产品受冷热变化的能力; 试验前后感值变化率均在10%范围内, OK |
| 4. 低温保存试验 | 温度: -40°C ± 2°C 时间: 100小时, 取出后在常温下放置1小时至不超过2小时再检查外观及特性 | 试验前后感值变化率均在10%范围内, OK |
| 5. 高温保存试验 | 温度: 125°C ± 2°C 时间: 100小时, 取出后在常温下放置1小时至不超过2小时再检查外观及特性 | 试验前后感值变化率均在10%范围内, OK |
| 6. 板弯试验 | 产品焊接在PCB上, 压力从PCB底部 (即产品底部的中点) 持续施加到2mm的弯曲深度, 保持到30s | 测试后无外观缺陷 |
| 7. 推拉力强度测试 | 将产品焊在PCB板上, 用数显式推拉力计从侧面推 | 产品上基板后强度是否达到客户要求 |
| 8. 可焊性试验 | 端子涂布助焊剂, 然后浸入锡银铜245 ± 5°C锡炉中5 ± 0.5秒, 端子必须有95%以上着锡为良品 | 端子必须有95%以上着锡为良品 |
| 9. 跌落试验 | 样品离地1M自由落下, 连续10次跌落包装箱不同的点、线、面 (6个面3条边1个点)。 | 感值变化率在9%以内且无明显的外观缺陷为良品, 包材无明显破损 |
| 10. 振动试验 | 1、将制品包装放入振动试验机来回振动1个时/每个面 (3个面), 振动周波数10~55~10HZ全振幅1.5mm。 | 感值变化率在10%以内且无明显的外观缺陷为良品, 包材无明显破损 |
| 11. 加压强度试验 | 1. 将产品固定在铁板上, 用数显式推拉力计从产品边角上压, 以测试产品的强度 | 产品强度是否达到客户要求 |
| | | |

第 1 页

| | | | |
|---------------|-----------------|-----------|----------|
| CUSTOMER: | | PAGE: | 4/10 |
| CUSTOMER P/N: | | REVISION: | |
| Cybermax P/N: | CMCW1608F4R7KTT | DATE: | 18.10.27 |
| DRAWN NO.: | CM18102703 | | |

REFLOW -PROFILE

Lead-free the recommended reflow condition(temperature chart)

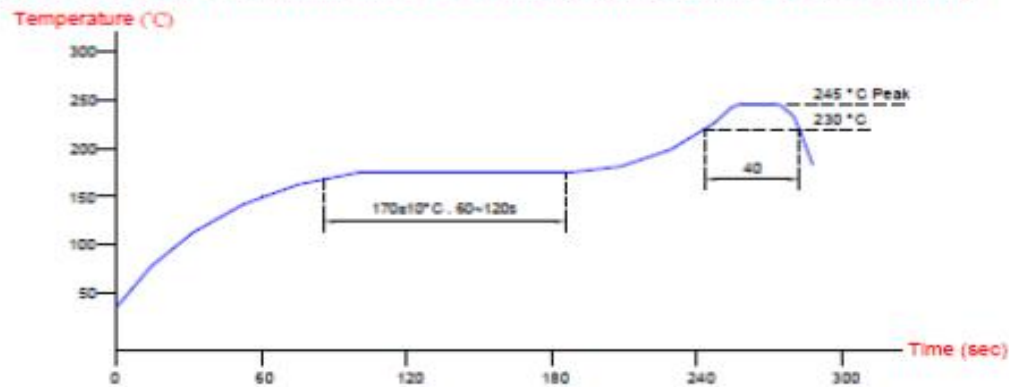

The reflow condition recommended above is according to the machine used by our company. Big differences will arise as a result of the type of machine, reflow conditions, method, etc used. Hence, before setting up your reflow conditions, please confirm with the above.

Lead-free heat endurance test

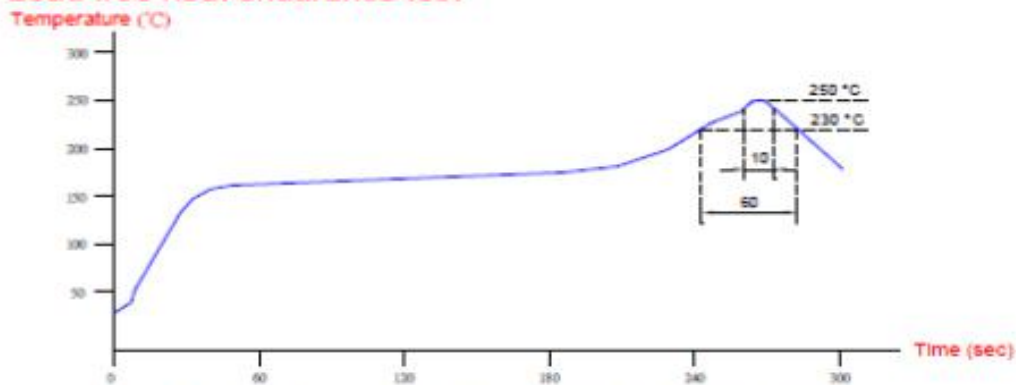

The test should be made under the conditions according to the chart, after the test it is kept for 2 hours under the normal temperature and humidity. The reflow test can be done twice, but the interval should be more than one hour under the normal conditions. The reflow test conditions are based on the testing instruments available in Aritech.

| | | | |
|---------------|-----------------|-----------|-----------------|
| CUSTOMER: | | PAGE: | 5/10 |
| CUSTOMER P/N: | | REVISION: | |
| Cybermax P/N: | CMCW1608F4R7KTT | DATE: | 18.10.27 |
| DRAWN NO.: | CM18102703 | | |

B.O.M

| 项目名称 | 型号及规格 | 制造商 | 环保要求 |
|---------------|----------------------|------|--------|
| Project name | | | EN. QU |
| 磁芯(DRUM CORE) | MF801SWI1608C050A-LS | 佳叶 | RoHS |
| 线材(WIRE) | P180G1-0.05mm | 益利素勒 | RoHS |
| 胶水(GLUE) | UV-523 | 贺盛 | RoHS |

| | | | |
|---------------|-----------------|-----------|-----------------|
| CUSTOMER: | | PAGE: | 6/10 |
| CUSTOMER P/N: | | REVISION: | |
| Cybermax P/N: | CMCW1608F4R7KTT | DATE: | 18.10.27 |
| DRAWN NO.: | CM18102703 | | |

Isat(飽和電流):電感瞬間的突波電流

CMCW1608F4R7KTT

| TME(秒) | Lsat(A) | L(UH) | $\Delta L/L(\%)$ |
|--------|---------|-------|------------------|
| 1 | 0.000 | 4.66 | 0.00% |
| 1 | 0.0495 | 4.66 | 0.00% |
| 1 | 0.0990 | 4.66 | 0.00% |
| 1 | 0.1485 | 4.66 | 0.00% |
| 1 | 0.1980 | 4.65 | -0.21% |
| 1 | 0.2475 | 4.64 | -0.43% |
| 1 | 0.2970 | 4.62 | -0.86% |
| 1 | 0.3465 | 4.57 | -1.93% |
| 1 | 0.3960 | 4.46 | -4.29% |
| 1 | 0.4455 | 4.12 | -11.59% |
| 1 | 0.4950 | 2.68 | -42.49% |

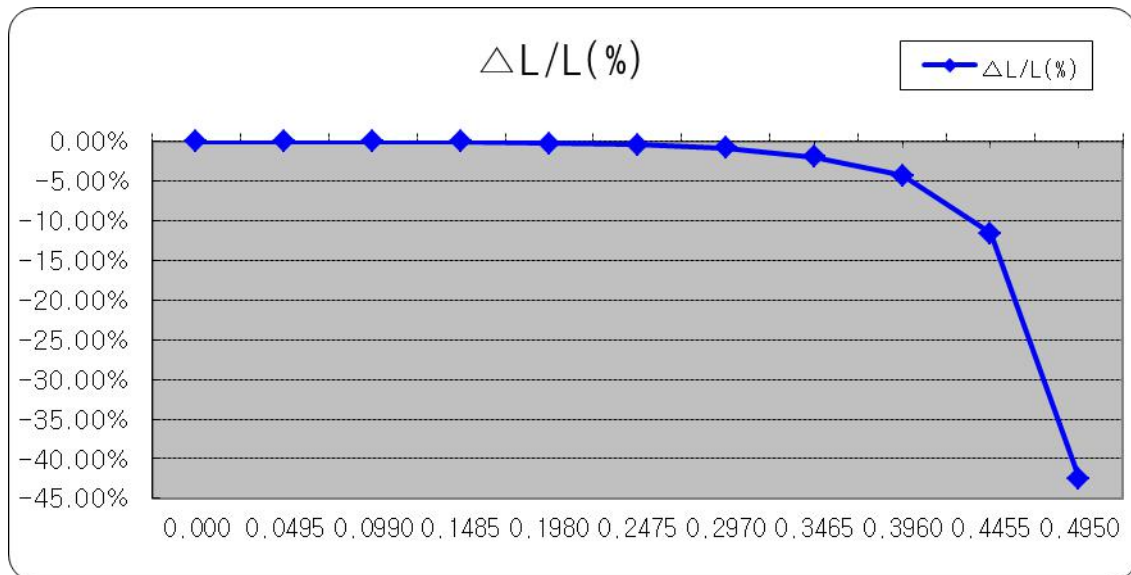

| | | | |
|---------------|-----------------|-----------|-----------------|
| CUSTOMER: | | PAGE: | 7/10 |
| CUSTOMER P/N: | | REVISION: | |
| Cybermax P/N: | CMCW1608F4R7KTT | DATE: | 18.10.27 |
| DRAWN NO.: | CM18102703 | | |

單點溫昇

CMCW1608F4R7KTT

| TIME(S) | Irms(A) | L(uH) | $\Delta L/L(\%)$ | Temp($^{\circ}C$) | $\Delta T(^{\circ}C)$ |
|---------|---------|-------|------------------|---------------------|-----------------------|
| 30 | 0.000 | 4.66 | 0.00% | 30.0 | 0.0 |
| 30 | 0.0495 | 4.65 | -0.21% | 30.0 | 0.0 |
| 30 | 0.0990 | 4.64 | -0.43% | 30.0 | 0.0 |
| 30 | 0.1485 | 4.63 | -0.64% | 31.0 | 1.0 |
| 30 | 0.1980 | 4.62 | -0.86% | 32.0 | 2.0 |
| 30 | 0.2475 | 4.60 | -1.29% | 33.0 | 3.0 |
| 30 | 0.2970 | 4.53 | -2.79% | 35.0 | 5.0 |
| 30 | 0.3465 | 4.48 | -3.86% | 37.0 | 7.0 |
| 30 | 0.3960 | 4.25 | -8.80% | 40.0 | 10.0 |
| 30 | 0.4455 | 3.52 | -24.46% | 43.0 | 13.0 |
| 30 | 0.4950 | 1.73 | -62.88% | 48.0 | 18.0 |

※DC bias current characteristics in the ambient temperature 25 $^{\circ}C$ Frequency 7.9MHz/0.2V

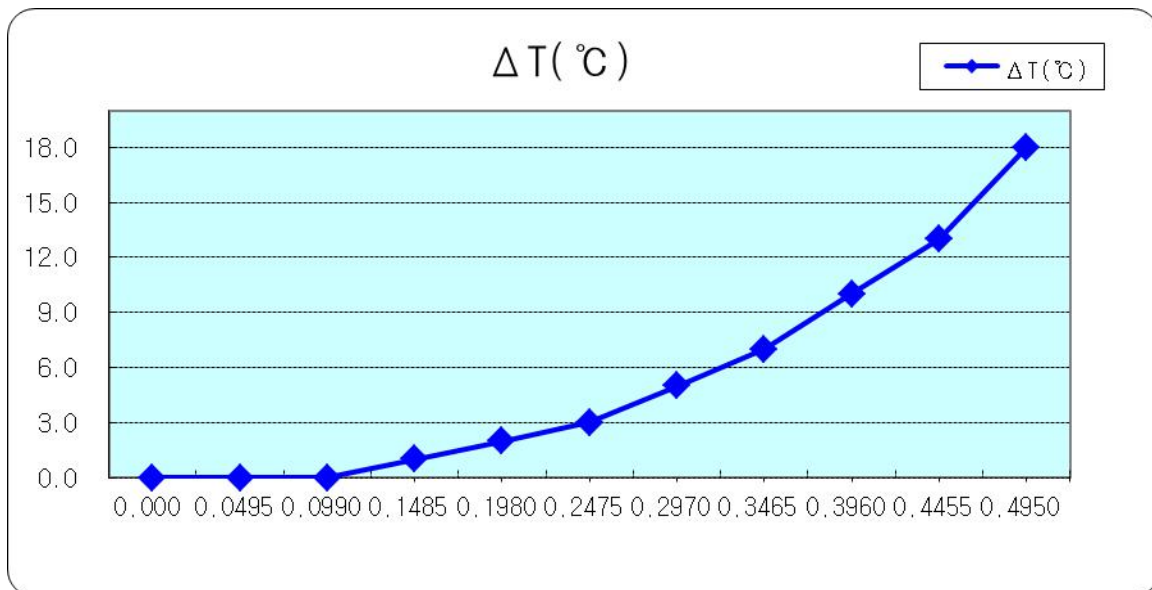

| | | | |
|---------------|-----------------|-----------|-----------------|
| CUSTOMER: | | PAGE: | 8/10 |
| CUSTOMER P/N: | | REVISION: | |
| Cybermax P/N: | CMCW1608F4R7KTT | DATE: | 18.10.27 |
| DRAWN NO.: | CM18102703 | | |

TEST DATA FOR PREPRODUCTION SAMPLE

| TEST RESOLUTION | | | | | DIMENSION (Unit: mm) | | |
|-----------------|--------------|--------------|--------------|---------------|----------------------|---------|---------|
| MEAS. | L | D.C.R | | | 长 | 宽 | 高 |
| ITEM | μH | mΩ | | | mm | mm | mm |
| SPEC. | 4.7 | 970 | | | Max.1.8 | Max.1.2 | Max.1.0 |
| | ± | ± | | | | | |
| | 10% | 30% | | | | | |
| TEST | 7.9MHz/0.1 | | "Isat | ΔL/L ≤ 30% | | | |
| FREQ. | V | | 0.4A | | | | |
| 1 | 4.66 | 793 | 4.40 | -5.6% | 1.67 | 1.05 | 0.99 |
| 2 | 4.63 | 792 | 4.38 | -5.4% | 1.65 | 1.06 | 0.98 |
| 3 | 4.64 | 802 | 4.37 | -5.8% | 1.66 | 1.04 | 0.97 |
| 4 | 4.66 | 799 | 4.39 | -5.8% | 1.68 | 1.13 | 0.96 |
| 5 | 4.66 | 797 | 4.40 | -5.6% | | | |
| 6 | 4.62 | 794 | 4.35 | -5.8% | | | |
| 7 | 4.66 | 803 | 4.39 | -5.8% | | | |
| 8 | 4.65 | 803 | 4.37 | -6.0% | | | |
| 9 | 4.65 | 804 | 4.38 | -5.8% | | | |
| 10 | 4.64 | 805 | 4.36 | -6.0% | | | |
| AVG. | 4.647 | 799.2 | 4.379 | -5.77% | | | |
| R | 0.04 | 13 | 1.60 | -4.20% | | | |

| APPROVED BY | CHECKED BY | DRAWN BY |
|---|---|---|
|  |  |  |

| | | | |
|---------------|-----------------|-----------|-----------------|
| CUSTOMER: | | PAGE: | 9/10 |
| CUSTOMER P/N: | | REVISION: | |
| Cybermax P/N: | CMCW1608F4R7KTT | DATE: | 18.10.27 |
| DRAWN NO.: | CM18102703 | | |

PACKAGING

热封包装

Reel dimensions

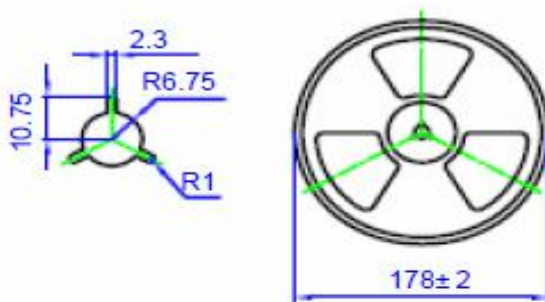

UNIT:mm

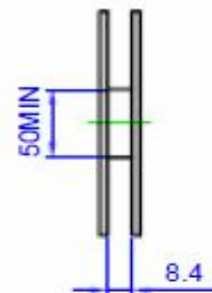

Tape dimensions

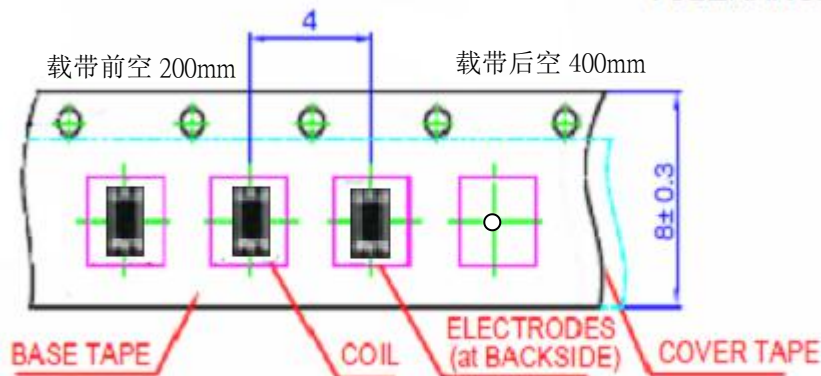

UNIT:mm
TOLERANCE:±0.1

Packaging

Quantity: **4000** pcs/reel

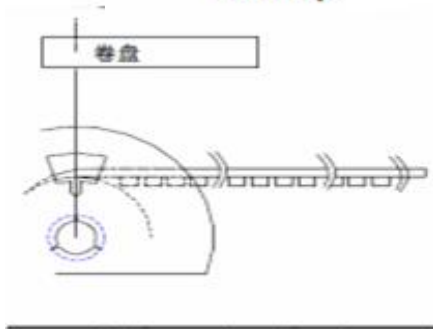

| | | | |
|---------------|-----------------|-----------|-----------------|
| CUSTOMER: | | PAGE: | 10/10 |
| CUSTOMER P/N: | | REVISION: | |
| Cybermax P/N: | CMCW1608F4R7KTT | DATE: | 18.10.27 |
| DRAWN NO.: | CM18102703 | | |

PACKAGING

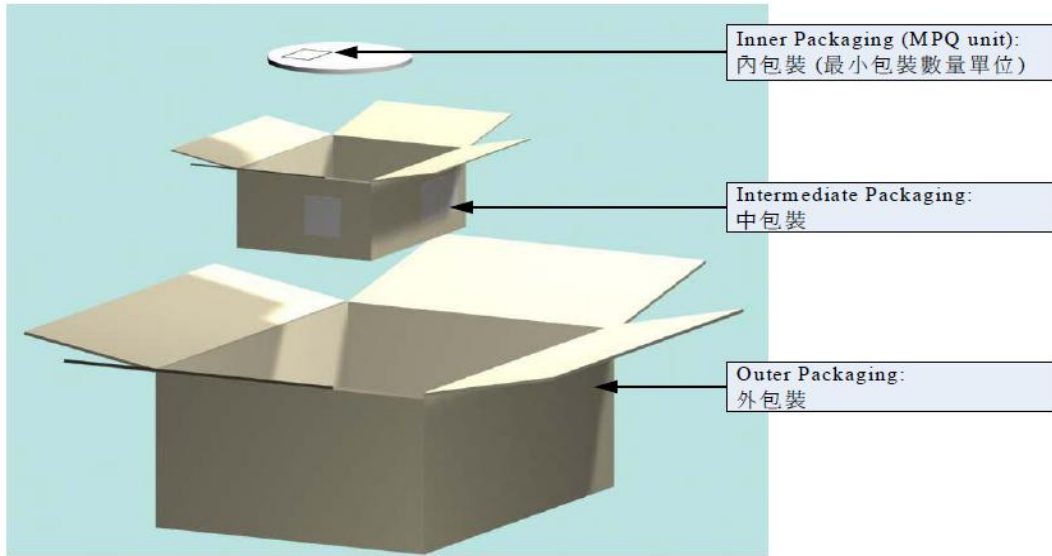

- 1.1 外箱: 39*38*18.5 cm 一箱裝 8 內箱
- 1.2 內箱: 18.7*18.4*8.3 cm 一箱裝 5 卷制品
- 1.3 外箱材質: A 三 A
- 1.4 內箱材質: A=A
- 1.5 每 5 卷制品用一只静电袋包裝
- 1.6 每一静电袋內放一只袋干燥剂
- 1.7 每一卷上面依标签樣式的要求貼上标签明細
- 1.8 出貨內外箱貼上該箱內实际內容明細
- 1.9 出貨标签規格如下: 尺寸=長度:39mm 寬度:29mm

(如: 客戶有特殊要求時, 則依客戶要求實施.)

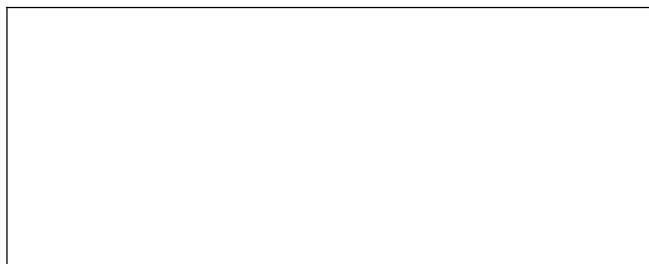

备注: 如果捆包数量小于內箱捆包数量時就用內箱包裝

X-ON Electronics

Largest Supplier of Electrical and Electronic Components

Click to view similar products for [Fixed Inductors](#) category:

Click to view products by [Cybermax](#) manufacturer:

Other Similar products are found below :

[CR32NP-151KC](#) [CR32NP-180KC](#) [CR32NP-181KC](#) [CR32NP-1R5MC](#) [CR32NP-390KC](#) [CR32NP-3R9MC](#) [CR32NP-680KC](#) [CR32NP-820KC](#) [CR32NP-8R2MC](#) [CR43NP-390KC](#) [CR43NP-560KC](#) [CR43NP-680KC](#) [CR54NP-181KC](#) [CR54NP-470LC](#) [CR54NP-820KC](#) [CR54NP-8R5MC](#) [70F224AI](#) [MGDQ4-00004-P](#) [MHL1ECTTP18NJ](#) [MHQ1005P10NJ](#) [MHQ1005P1N0S](#) [MHQ1005P2N4S](#) [MHQ1005P3N6S](#) [MHQ1005P5N1S](#) [MHQ1005P8N2J](#) [PE-51506NL](#) [PE-53601NL](#) [PE-53602NL](#) [PE-53630NL](#) [PE-53824SNLT](#) [PE-92100NL](#) [PG0434.801NLT](#) [PG0936.113NLT](#) [9220-20](#) [9310-16](#) [PM06-2N7](#) [PM06-39NJ](#) [A01TK](#) [1206CS-471XJ](#) [HC2LP-R47-R](#) [HC2-R47-R](#) [HC3-2R2-R](#) [HCF1305-3R3-R](#) [1206CS-151XG](#) [RCH664NP-140L](#) [RCH664NP-4R7M](#) [RCH8011NP-221L](#) [RCP1317NP-332L](#) [RCP1317NP-391L](#) [RCR1010NP-470M](#)