

0201 Series Thin Film Chip Inductor (Lead / Halogen Free)

1. Scope

This specification applies to 0.6mm x 0.3mm (0201) size, fixed thin film chip inductor rectangular type.

2. Type Designation

CML 0306 - *** - * NH

(1) (2) (3) (4) (5)

Where (1) Product Type

CML : fixed thin film chip inductor

(2) Size

0306 : 0.30 × 0.60mm

(3) Nominal inductance value : three digits of number, refer to Table 1.

The nominal inductance value shell is represented by two significant figures and a code "N" representing the unit.

(4) Tolerance

B : ±0.1nH ; C : ± 0.2nH ; S : ± 0.3nH

H : ± 3% ; J : ± 5%

(5) NH = Sn plating (Lead free / Halogen free)

3. Construction and Physical Dimensions

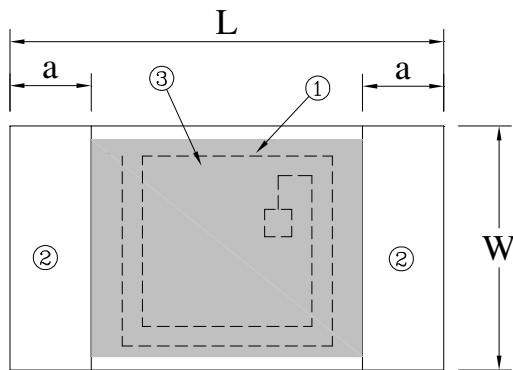

Code Letter	Dimensions
L	0.61 ± 0.05
W	0.31 ± 0.05
t	0.28 ± 0.05
a	0.08 ± 0.05
b	0.15 ± 0.05

Unit : mm

Note :

- ① Coil : Cu
- ② Electrode : plating
Sn plating (Lead free)
- ③ Protective Coat : Epoxy Resin coating
- ④ Substrate : Alumina ceramic

4. Specifications

Table 1 Electric Specification Characteristics

Inductance	Tolerance	Q	LQ Meas. Freq.	Self Resonance Freq.	DC Resistance	Rated Current
(nH)		min.	(MHz)	(MHz)min.	(Ω)max.	(mA)
CML0306-0N6	± 0.1nH	---	100	6000	0.10	500
CML0306-0N7		---		6000	0.10	490
CML0306-0N8	± 0.2nH	---		6000	0.10	490
CML0306-0N9		---		6000	0.10	480
CML0306-1N0	± 0.3nH	---		6000	0.10	470
CML0306-1N1		---		6000	0.10	460
CML0306-1N2		---		6000	0.10	450
CML0306-1N3		4		6000	0.12	440
CML0306-1N4		4		6000	0.13	440
CML0306-1N5		4		6000	0.16	430
CML0306-1N6		4		6000	0.16	420
CML0306-1N7		4		6000	0.20	410
CML0306-1N8		4		6000	0.20	390
CML0306-1N9		4		6000	0.20	390
CML0306-2N0		4		6000	0.20	380
CML0306-2N1		4		6000	0.20	370
CML0306-2N2		4		6000	0.20	360
CML0306-2N3		4		6000	0.20	360
CML0306-2N4		4		6000	0.20	350
CML0306-2N5		4		6000	0.20	340
CML0306-2N6		4		6000	0.20	340
CML0306-2N7		5		6000	0.23	340
CML0306-2N8		5		6000	0.25	330
CML0306-2N9		5		6000	0.25	330
CML0306-3N0		5		6000	0.25	330
CML0306-3N1		5		6000	0.25	330
CML0306-3N2		5		6000	0.25	330
CML0306-3N3		5		6000	0.30	320
CML0306-3N4		5		6000	0.32	310
CML0306-3N5		5		6000	0.32	310
CML0306-3N6		5		6000	0.32	310
CML0306-3N7	5	6000		0.40	300	

CML0306-3N8	± 3%	5	100	6000	0.40	300	
CML0306-3N9		5		6000	0.40	300	
CML0306-4N3		5		6000	0.40	280	
CML0306-4N7		5		6000	0.45	280	
CML0306-5N1		5		6000	0.45	270	
CML0306-5N6		5		6000	0.50	270	
CML0306-6N2		5		6000	0.55	250	
CML0306-6N8		5		5500	0.70	250	
CML0306-7N5		5		5000	1.10	240	
CML0306-8N2		± 5%		5	5000	1.20	230
CML0306-9N1				5	4500	1.20	220
CML0306-10N				5	4500	1.30	220
CML0306-12N				5	3700	1.30	190
CML0306-15N				5	3700	1.50	180
CML0306-18N				5	3100	1.60	170
CML0306-22N	5		2800	1.80	150		

● L, Q vs Frequency Typical Characteristics Chart

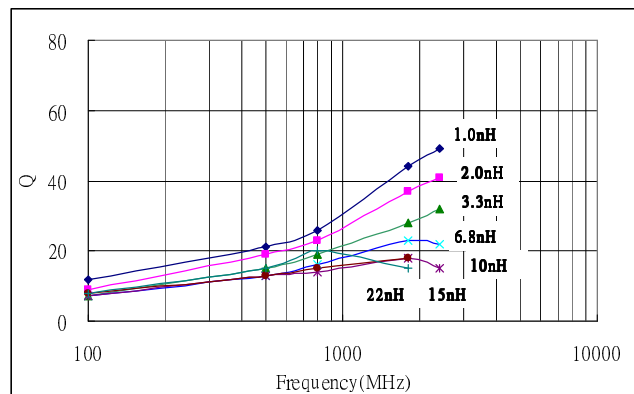
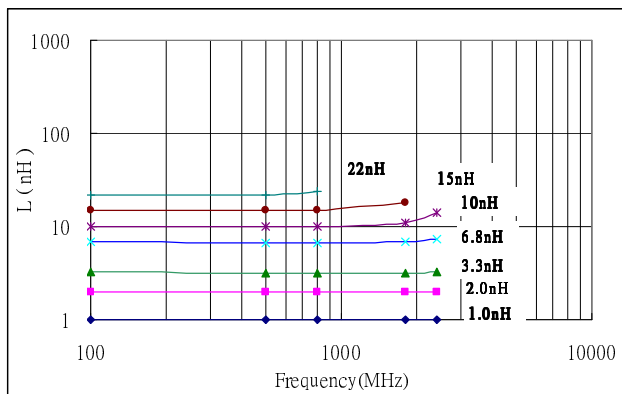

● L, Q vs Frequency Reference Characteristics Table

Part Number	Inductance (nH)				Q			
	500MHz	800MHz	1.8GHz	2.4GHz	500MHz	800MHz	1.8GHz	2.4GHz
CML0306-0N6	0.6	0.6	0.6	0.6	25min	30min	45min	50min
CML0306-0N7	0.7	0.7	0.7	0.7	25min	30min	45min	50min
CML0306-0N8	0.8	0.8	0.8	0.8	25min	30min	45min	50min
CML0306-0N9	0.9	0.9	0.9	0.9	24min	30min	45min	50min
CML0306-1N0	1	1	1	1	25	31	45	51
CML0306-1N1	1.1	1.1	1.1	1.1	25	31	45	52
CML0306-1N2	1.2	1.2	1.2	1.2	25	31	45	52
CML0306-1N3	1.3	1.3	1.3	1.3	24	30	45	52
CML0306-1N4	1.3	1.3	1.3	1.3	22	28	41	48
CML0306-1N5	1.5	1.4	1.4	1.4	21	26	39	45
CML0306-1N6	1.6	1.6	1.6	1.6	19	23	38	43
CML0306-1N7	1.7	1.7	1.7	1.7	19	24	37	43
CML0306-1N8	1.8	1.8	1.8	1.8	19	25	38	43
CML0306-1N9	1.9	1.9	1.9	1.9	20	25	38	43
CML0306-2N0	2	2	2	2	20	25	38	42
CML0306-2N1	2.1	2.1	2.1	2.1	20	25	38	43
CML0306-2N2	2.2	2.2	2.2	2.2	21	26	38	44
CML0306-2N3	2.3	2.3	2.3	2.3	21	26	37	43
CML0306-2N4	2.4	2.4	2.4	2.4	20	25	37	43
CML0306-2N5	2.5	2.5	2.5	2.5	20	25	37	42
CML0306-2N6	2.6	2.6	2.6	2.6	19	24	35	40
CML0306-2N7	2.7	2.6	2.6	2.7	19	24	35	40
CML0306-2N8	2.8	2.8	2.8	2.8	18	23	33	38
CML0306-2N9	2.9	2.9	2.9	2.9	18	22	33	37
CML0306-3N0	3	3	3	3	17	21	32	37
CML0306-3N1	3.1	3.1	3.1	3.1	17	21	30	33
CML0306-3N2	3.2	3.2	3.2	3.3	17	21	31	35
CML0306-3N3	3.3	3.3	3.3	3.3	17	21	31	35
CML0306-3N4	3.4	3.4	3.4	3.4	17	21	31	35
CML0306-3N6	3.5	3.5	3.6	3.7	15	19	28	30
CML0306-3N9	3.7	3.7	3.8	4	17	21	31	34
CML0306-4N3	4.1	4.1	4.3	4.5	17	22	31	34
CML0306-4N7	4.5	4.5	4.7	5	16	19	28	30
CML0306-5N1	5	5	5.2	5.6	17	19	28	29

CYNTEC CO., LTD.

乾坤科技股份有限公司

DOCUMENT : CYNP-8Z-031

REVISION : A5

PAGE : 5 OF 15

CML0306-5N6	5.6	5.6	5.8	6.1	16	19	28	29
CML0306-6N2	6.2	6.2	6.4	6.7	16	19	27	27
CML0306-6N8	6.6	6.6	6.9	7.3	16	19	27	27
CML0306-7N5	7.3	7.3	7.8	8.4	16	19	27	27
CML0306-8N2	8	8	8.3	9.1	15	19	23	22
CML0306-9N1	8.9	8.9	9.4	10.5	12	15	20	20
CML0306-10N	10	10	11	12.5	15	17	20	18
CML0306-12N	12	12	14	18	13	15	18	15
CML0306-15N	15	15	18	---	13	15	18	---
CML0306-18N	18	18	24	---	13	15	17	---
CML0306-22N	22	24	---	---	15	20	15	---

5. Characteristics

Unless otherwise specified, the standard range of atmospheric conditions for marking measurements tests is as follows;

Temperature	24 ± 5°C
Relative humidity	45 to 85%RH
Air pressure	86 to 106kPa

If there is any doubt about results, measurements shall be made within the following limits;

Temperature	20 ± 2°C
Relative humidity	60 to 70%RH
Air pressure	86 to 106kPa

5-1 Electrical

Item	Conditions	Specifications
Inductance	Measurement shall be performed by Impedance Analyzer 4287A with the frequency specified in Table 1.	Refer to Table 1.
Q value	Measurement shall be performed by Impedance Analyzer 4287A with the frequency specified in Table 1.	Refer to Table 1.
DC Resistance	Refer to IEC 60115-1, Sub-clause 4.5.	DC Resistance shall be within the specified tolerance.
Self Resonance Frequency	Measurement shall be performed by Network Analyzer Agilent N5230A.	Self resistance frequency shall be within the specified frequency. (Table 1.)
Temperature Coefficient	Measurement shall be performed at RT and RT+100°C , and the calculation shall be performed with the measured values.	TCL : 0 ~ +125 ppm/°C. TCQ : -0.25% ~ 0%/°C TCR : 0 ~ +0.45% /°C
Overload	Test current : 2 times of the maximum current. Duration : 5 minutes	No smoke, Fire nor significant damage shall be observed.

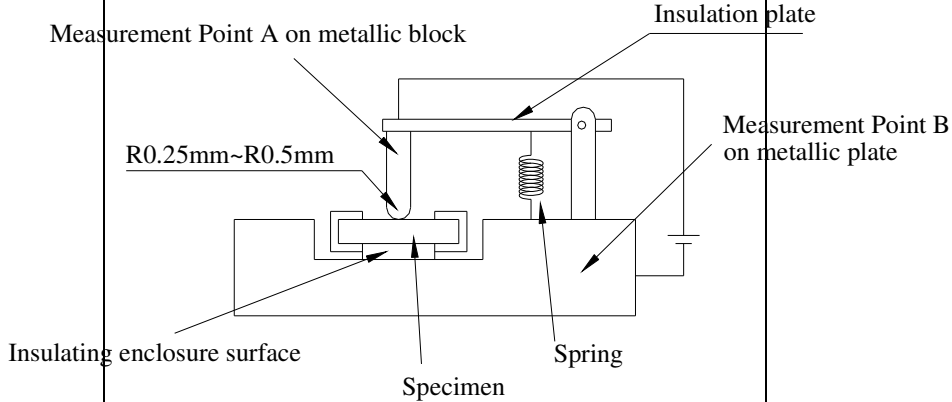
Item	Conditions	Specifications
Rated Current	Rated current shall be the current with which the temperature raise of the inductor becomes 20°C.	Refer to Table 1.
Insulation Resistance	<p>Place the specimen on the groove of metal plate so that the edge of metal block positions almost center of both electrodes, with the surface of insulation enclosure located downward or upward and pressurize the block by a force or $1.0 \pm 0.2N$. The test voltage shall be $100 \pm 15V_{dc}$, and maintain this voltage for about 1 minute. The insulation resistance shall then be measured while applying the voltage.</p>  <p style="text-align: center;">Figure 2 : Measurement Setup</p> <p>Refer to IEC 60115-1, Sub-clause 4.6</p>	<p>(1) Between Electrode and insulating enclosure. $100M\Omega$ or more</p> <p>(2) Between Electrode and base material $1,000M\Omega$ or more</p>
Voltage Proof	<p>The inductor shall be tested as shown in Figure 2. Test Voltage : 100VAC (rms.) for 60 ± 5 seconds</p> <p>Refer to IEC 60115-1, Sub-clause 4.7.</p>	<p>No mechanical damage shall be observed. Electrical characteristics shall be within specification.</p>

5-2 Mechanical

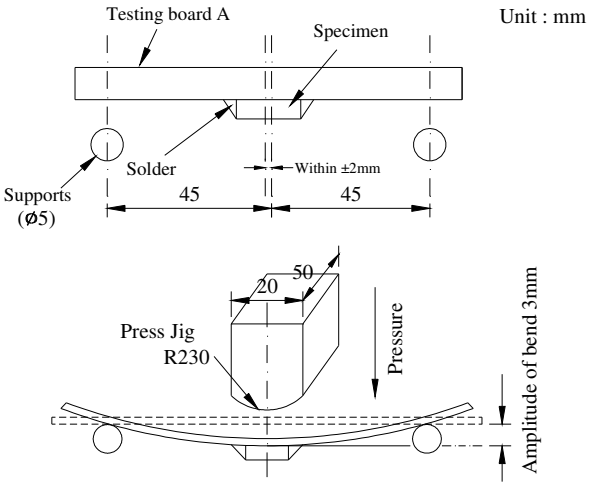
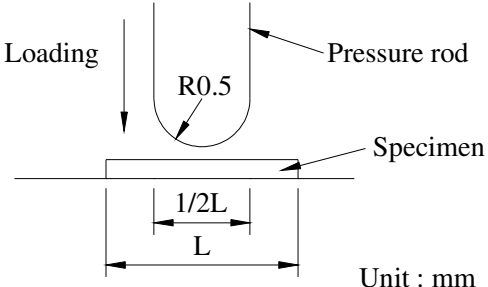
Item	Conditions	Specifications
Substrate bending test (Bond strength of the face plating)	<p>Apply pressure in the direction of the arrow at a rate of about 1mm/s. until bent width reaches 3 mm and hold for 30 seconds.</p>  <p>Unit : mm</p> <p>Refer to IEC 60115-1, Sub-clause 4.33</p>	<p>No mechanical damage shall be observed.</p> <p>DC Resistance Characteristics shall be within specification.</p>
Body Strength	<p>A load of 10N (1.02kgf) using a R0.5 pressure rod shall be applied to the center in the direction of arrow and held for 10 ± 1 seconds.</p>  <p>Unit : mm</p>	<p>No mechanical damage shall be observed.</p> <p>Electric characteristics shall be within specification.</p>

Item	Conditions	Specifications
Resistance to Soldering Heat	<p>(1) Solder bath method Pre-heat : 100 to 110°C 30 seconds Temperature : 270 ± 5°C 10 ± 1seconds</p> <p>(2) Reflow Soldering method Peak temperature : 260 ± 5°C 10seconds or less Temperature : 220 ± 5°C 60 seconds max. 2cycles or less The temperature shall be board surface temperature</p> <p>(3) Soldering iron method Bit temperature : 350 ± 5°C Time : 3 +1/-0 seconds</p> <p>The specimen shall be stored at standard atmospheric conditions for 1hour after which the measurement shall be made.</p> <p>Refer to IEC 60115-1, Sub-clause 4.18</p>	<p>No mechanical damage shall be observed. Electrical characteristics shall be within specification.</p>
Solderability	<p>Solder temperature : 245 ± 5°C Duration of immersion : 2 ± 0.5 seconds</p> <p>Refer to IEC 60115-1, Sub-clause 4.17</p>	<p>A new uniform coating of 95% of the surface being immersed.</p>
Solvent Resistance	<p>Immersion cleaning At normal temperature 5 minutes Isopropyl alcohol.</p> <p>Refer to IEC 60115-1, Sub-clause 4.29</p>	<p>Without distinct damage in appearance.</p>

5-3 Endurance

Item	Conditions	Specifications															
Rapid change of temperature	The specimen shall be subjected to 5 continuous cycles, each as shown in the figure below.																
		<table border="1"> <thead> <tr> <th></th> <th>Temperature</th> <th>Time</th> </tr> </thead> <tbody> <tr> <td>1</td> <td>-40 ± 3°C</td> <td>30 minutes</td> </tr> <tr> <td>2</td> <td>Room temperature</td> <td>2 ~ 3minutes</td> </tr> <tr> <td>3</td> <td>+125 ± 2°C</td> <td>30 minutes</td> </tr> <tr> <td>4</td> <td>Room temperature</td> <td>2 ~ 3minutes</td> </tr> </tbody> </table>		Temperature	Time	1	-40 ± 3°C	30 minutes	2	Room temperature	2 ~ 3minutes	3	+125 ± 2°C	30 minutes	4	Room temperature	2 ~ 3minutes
		Temperature	Time														
	1	-40 ± 3°C	30 minutes														
	2	Room temperature	2 ~ 3minutes														
3	+125 ± 2°C	30 minutes															
4	Room temperature	2 ~ 3minutes															
Use for Testing board B		<p>No mechanical damage shall be observed. Electrical characteristics shall be within specification.</p>															
Refer to IEC 60115-1, Sub-clause 4.19																	

Mounting of the test sample onto the test board shall be either of following methods.

(1) Mounting by solder dipping

Epoxy based glue shall be applied in the middle of two lands of the test board. The resistor shall be mounted in such a way that the electrodes of resistors will be evenly placed in the land area and then adhesive resin shall be cured. After applying the Resin Flux with 25 weight % Methyl Alcohol, the board shall be soldered by dipping into a molten solder bath with $260 \pm 5^\circ\text{C}$ for 3 to 5 seconds

(2) Mounting by Reflow soldering

Solder paste with approximate $100 \mu\text{m}$ thickness shall be applied to the land of test board. The resistor shall be mounted in such way that the electrodes of resistors will be evenly placed in the land area and then shall be soldered under the circumstance that the surface temperature of the board shall be raised $245 \pm 5^\circ\text{C}$ (peak) for 5 to 10 seconds in an upper-heater oven.

Test board

Material : Glass Fabric Epoxy Resin (Refer to JIS C 6484)

Board thickness : 1.6mm

Copper foil thickness : 0.035mm

Solder Resist Coating

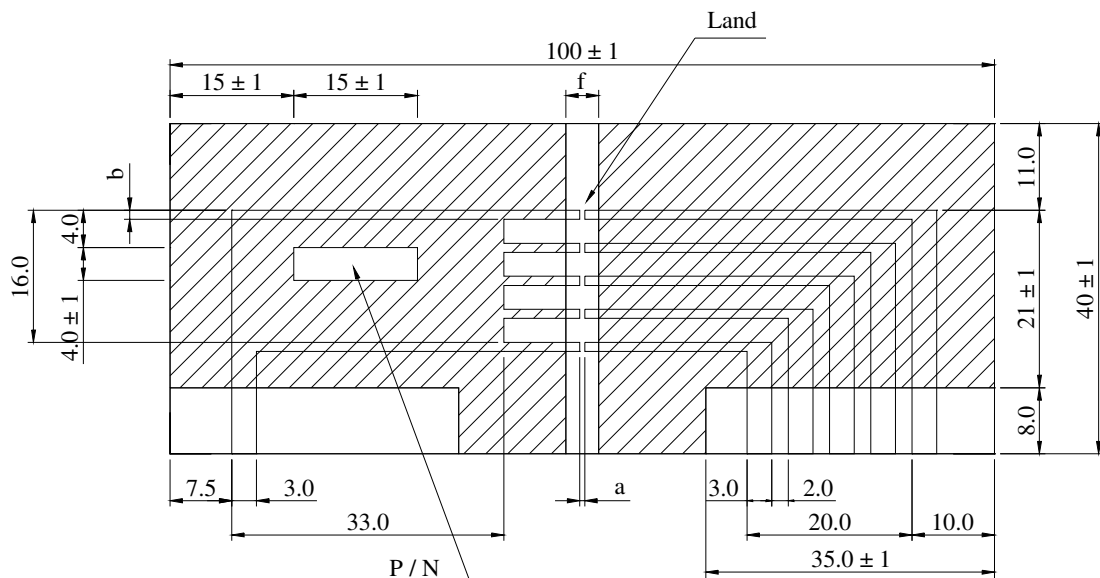

a	b	c
0.28 ± 0.02	0.34 ± 0.02	0.76 ± 0.04

Unit : mm

6. Packaging

6-1 Dimensions

6-1-1 Tape Packaging Dimensions

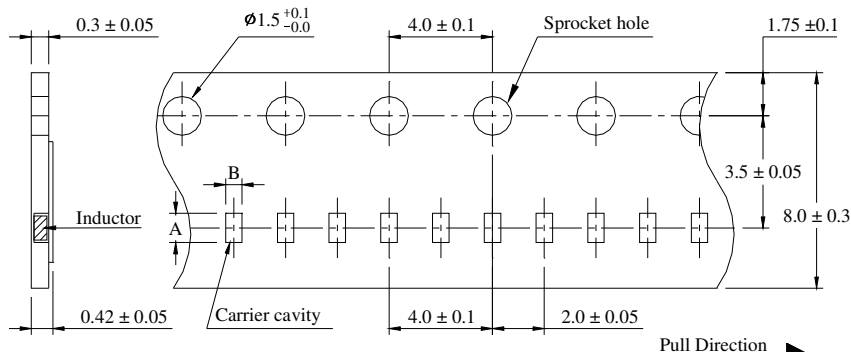

※ “Bottom less type” of tape is used.

※ Pre-empted holes : 150 holes (or 30cm) or more

Code Letter	A	B
Dimension	0.70 ± 0.03	0.43 ± 0.03

Unit : mm

6-1-2 Reel Dimensions

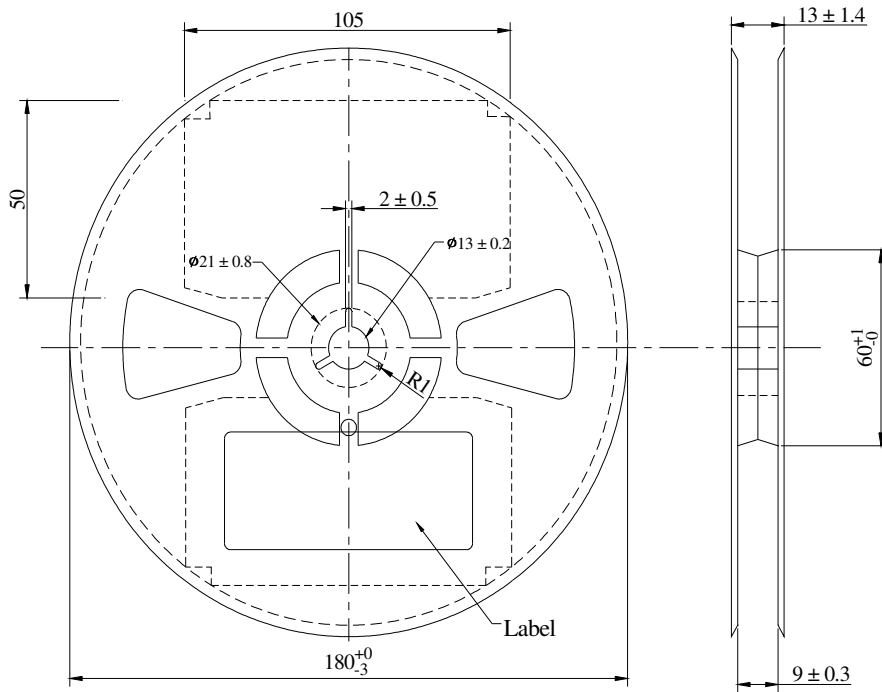

Unit : mm

Plastic Reel Thickness : 0.5mm

Plastic Reel : Correspond with EIAJ RRV08B

6-2 Peel Strength of Top Cover Tape

The peel speed shall be about 300 mm/minute

The peel strength of top cover tape shall be between 0.1 to 0.7N.

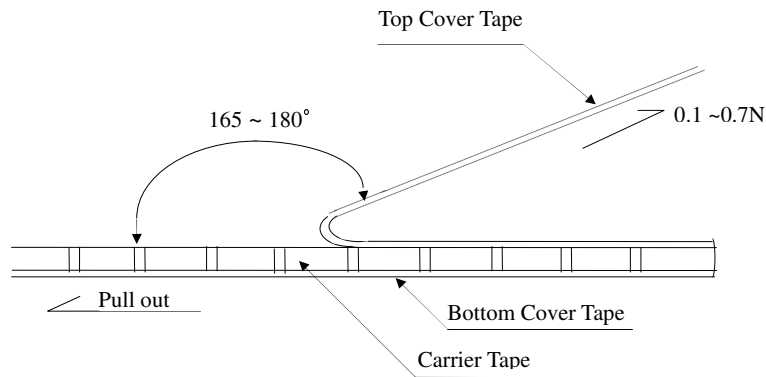

6-3 Quantity per Reel

10,000 pieces / reel

6-4 Label Marking

The following items shall be marked on the reel.

- (1) Manufactures parts number
- (2) Quantity
- (3) Manufacturing date code
- (4) Manufacturer's name
- (5) The country of origin
- (6) Shipping number
- (7) Identification showing lead-free products.

7. Precautions

7-1 Storage

- (1) The product shall be stored in a room where temperature and humidity must be controlled. (temperature: 5-35°C, humidity : 45-85% RH).
However, humidity keeps it low, as it is possible.
- (2) The product shall be stored as direct sunshine doesn't hit on it.
- (3) The product shall be stored with on moisture, dust, a material that will make solderability inferior, and a harmful gas (hydrogen chloride, sulfurous acid gas, and hydrogen sulfide).
- (4) The product shall be stored as tape packaging condition.

7-2 Term for use

- (1) The term for use is within one year from the shipping day of the product.
- (2) If the product has been left unused for more than one year after delivered, check solderability before use.

7-3 Chip mounting

- (1) When chip are mounted on PC board, protective coat of the product must not be scratched. If it will be scratched, it will make characteristic inferior.
- (2) In case that product will be soldered by soldering iron, heating shall be done on the land, and soldering iron must not hit on the product itself.
- (3) In case that resin coating or resin seal will be made for a PC board after chip mounting, do washing and drying it enough before coating or sealing. If ion bear or moisture will be sealed in resin coating, it will make characteristic inferior.
- (4) For resinous use, it is necessary to set up enough the curing conditions. As it gets improper for the condition, changes of a resistance value are large and are a case.
- (5) According to shape, material, and pressure of clamping in chip mounting machine, there is the case that crack will be appeared on the product.

Control a shock energy for clamping the product under 7×10^{-4} J .

With a shock energy around clamping that says here, it is suited to a potential energy, in case that iron block of 25 g is dropped naturally to the product placed on iron plate for the height of 2.8mm.

- (6) The glue to fix the product on the PC board around chip mounting, it is needed high insulation resistance and great performance or moisture. And it is needed that these characteristics are not inferno in using temperature range and a hot spot temperature to be acting.

7-4 Using and Handling

- (1) It is necessary to investigate the performance and reliability enough when using under harsh environment.
- (2) It is necessary to protect the and protective coat of the product from mechanical stress.
- (3) Handle with care when PC board is divided or fixed on support body, because bending of PC board after chip mounting will make mechanical stress for the product.
- (4) The product shall be used within rated range shown in specification.
Especially, if current more than specified value will be loaded to the product, there is a case it will make damage for machine because of temperature rise depending on generation of heat, and characteristic inferior.
- (5) In case that product is loaded a rated current, it is necessary to confirm temperature of the product and to reduce a load current according to load reduction curve, because a temperature rise of the product depends on influence of heat from mounting density and neighboring element.
- (6) If there is a possibility that a large voltage (pulse voltage, shock voltage) charge to the product, It is necessary that operating condition shall be set up before use, because performance of the product is affected by a large shock voltage.
- (7) The items listed listed in the specifications assure the product quality as the product alone. Evaluation and confirmation of the product quality after mounting, in accordance with the operation condition, is required for actual use.

X-ON Electronics

Largest Supplier of Electrical and Electronic Components

Click to view similar products for [Fixed Inductors](#) category:

Click to view products by [Cyntech](#) manufacturer:

Other Similar products are found below :

[CR32NP-100KC](#) [CR32NP-151KC](#) [CR32NP-180KC](#) [CR32NP-181KC](#) [CR32NP-1R5MC](#) [CR32NP-390KC](#) [CR32NP-3R9MC](#) [CR32NP-680KC](#) [CR32NP-820KC](#) [CR32NP-8R2MC](#) [CR43NP-390KC](#) [CR43NP-560KC](#) [CR43NP-680KC](#) [CR54NP-181KC](#) [CR54NP-470LC](#) [CR54NP-820KC](#) [CR54NP-8R5MC](#) [70F224AI](#) [MGDQ4-00004-P](#) [MHL1ECTTP18NJ](#) [MHQ1005P10NJ](#) [MHQ1005P1N0S](#) [MHQ1005P2N4S](#) [MHQ1005P3N6S](#) [MHQ1005P5N1S](#) [MHQ1005P8N2J](#) [PE-51506NL](#) [PE-53601NL](#) [PE-53602NL](#) [PE-53630NL](#) [PE-53824SNLT](#) [PE-92100NL](#) [PG0434.801NLT](#) [PG0936.113NLT](#) [9220-20](#) [9310-16](#) [PM06-2N7](#) [PM06-39NJ](#) [A01TK](#) [1206CS-471XJ](#) [HC2LP-R47-R](#) [HC2-R47-R](#) [HC3-2R2-R](#) [HCF1305-3R3-R](#) [1206CS-151XG](#) [RCH664NP-140L](#) [RCH664NP-4R7M](#) [RCH8011NP-221L](#) [RCP1317NP-332L](#) [RCP1317NP-391L](#)