



# *AMD Geode™ LX Processors Data Book*

---

*February 2009*

Publication ID: 33234H

---

© 2009 Advanced Micro Devices, Inc. All rights reserved.

The contents of this document are provided in connection with Advanced Micro Devices, Inc. (“AMD”) products. AMD makes no representations or warranties with respect to the accuracy or completeness of the contents of this publication and reserves the right to make changes to specifications and product descriptions at any time without notice. No license, whether express, implied, arising by estoppel or otherwise, to any intellectual property rights is granted by this publication. Except as set forth in AMD’s Standard Terms and Conditions of Sale, AMD assumes no liability whatsoever, and disclaims any express or implied warranty, relating to its products including, but not limited to, the implied warranty of merchantability, fitness for a particular purpose, or infringement of any intellectual property right.

AMD’s products are not designed, intended, authorized or warranted for use as components in systems intended for surgical implant into the body, or in other applications intended to support or sustain life, or in any other application in which the failure of AMD’s product could create a situation where personal injury, death, or severe property or environmental damage may occur. AMD reserves the right to discontinue or make changes to its products at any time without notice.

## **Contacts**

[www.amd.com](http://www.amd.com)

## **Trademarks**

AMD, the AMD Arrow logo, AMD Athlon, Geode, GeodeLink, 3DNow!, and combinations thereof, are trademarks of Advanced Micro Devices, Inc.

Linux is a registered trademark of Linus Torvalds.

WinBench is a registered trademark of Ziff Davis, Inc.

Windows is a registered trademark of Microsoft Corporation in the United States and/or other jurisdictions.

Pentium is a registered trademark and MMX is a trademark of Intel Corporation in the United States and/or other jurisdictions.

Other product names used in this publication are for identification purposes only and may be trademarks of their respective companies.

# Contents

<b>List of Figures</b> .....	<b>5</b>
<b>List of Tables</b> .....	<b>7</b>
<b>1.0 Overview</b> .....	<b>11</b>
1.1 General Description .....	11
1.2 Features .....	12
<b>2.0 Architecture Overview</b> .....	<b>15</b>
2.1 CPU Core .....	15
2.2 GeodeLink™ Control Processor .....	16
2.3 GeodeLink™ Interface Units .....	16
2.4 GeodeLink™ Memory Controller .....	16
2.5 Graphics Processor .....	17
2.6 Display Controller .....	18
2.7 Video Processor .....	18
2.8 Video Input Port .....	18
2.9 GeodeLink™ PCI Bridge .....	18
2.10 Security Block .....	19
<b>3.0 Signal Definitions</b> .....	<b>21</b>
3.1 Buffer Types .....	23
3.2 Bootstrap Options .....	24
3.3 Ball Assignments .....	24
3.4 Signal Descriptions .....	33
<b>4.0 GeodeLink™ Interface Unit</b> .....	<b>45</b>
4.1 MSR Set .....	45
4.2 GLIU Register Descriptions .....	50
<b>5.0 CPU Core</b> .....	<b>89</b>
5.1 Core Processor Initialization .....	89
5.2 Instruction Set Overview .....	90
5.3 Application Register Set .....	91
5.4 System Register Set .....	94
5.5 CPU Core Register Descriptions .....	99

<b>6.0</b>	<b>Integrated Functions</b>	<b>209</b>
6.1	GeodeLink™ Memory Controller	210
6.2	GeodeLink™ Memory Controller Register Descriptions	219
6.3	Graphics Processor	237
6.4	Graphics Processor Register Definitions	254
6.5	Display Controller	278
6.6	Display Controller Register Descriptions	300
6.7	Video Processor	388
6.8	Video Processor Register Descriptions	412
6.9	Video Input Port	462
6.10	Video Input Port Register Descriptions	482
6.11	Security Block	510
6.12	Security Block Register Descriptions	513
6.13	GeodeLink™ Control Processor	533
6.14	GeodeLink™ Control Processor Register Descriptions	539
6.15	GeodeLink™ PCI Bridge	566
6.16	GeodeLink™ PCI Bridge Register Descriptions	572
<b>7.0</b>	<b>Electrical Specifications</b>	<b>597</b>
7.1	Electrical Connections	597
7.2	Absolute Maximum Ratings	597
7.3	Operating Conditions	598
7.4	DC Current	599
7.5	DC Characteristics	604
7.6	AC Characteristics	607
<b>8.0</b>	<b>Instruction Set</b>	<b>619</b>
8.1	General Instruction Set Format	619
8.2	CPUID Instruction Set	627
8.3	Processor Core Instruction Set	633
8.4	MMX™, FPU, and AMD 3DNow!™ Technology Instructions Sets	658
<b>9.0</b>	<b>Package Specifications</b>	<b>675</b>
9.1	Physical Dimensions	675
<b>Appendix A</b>	<b>Support Documentation</b>	<b>677</b>
A.1	Order Information	677
A.2	Data Book Revision History	679

# List of Figures

Figure 1-1.	Internal Block Diagram . . . . .	11
Figure 3-1.	Signal Groups . . . . .	21
Figure 3-2.	BGU481 Ball Assignment Diagram . . . . .	25
Figure 4-1.	GeodeLink™ Architecture . . . . .	46
Figure 6-1.	Integrated Functions Block Diagram . . . . .	209
Figure 6-2.	GLMC Block Diagram . . . . .	210
Figure 6-3.	HOI Addressing Example . . . . .	211
Figure 6-4.	HOI Example . . . . .	211
Figure 6-5.	LOI Addressing Example . . . . .	212
Figure 6-6.	LOI Example . . . . .	212
Figure 6-7.	Request Pipeline . . . . .	215
Figure 6-8.	DDR Reads . . . . .	216
Figure 6-9.	DDR Writes . . . . .	217
Figure 6-10.	Graphics Processor Block Diagram . . . . .	237
Figure 6-11.	14-Bit Repeated Pattern . . . . .	244
Figure 6-12.	Display Controller High-Level Block Diagram . . . . .	278
Figure 6-13.	GUI Block Diagram . . . . .	279
Figure 6-14.	VGA Block Diagram . . . . .	280
Figure 6-15.	VGA Frame Buffer Organization . . . . .	288
Figure 6-16.	Graphics Controller High-level Diagram . . . . .	289
Figure 6-17.	Write Mode Data Flow . . . . .	290
Figure 6-18.	Read Mode Data Flow . . . . .	291
Figure 6-19.	Color Compare Operation . . . . .	292
Figure 6-20.	Graphics Filter Block Diagram . . . . .	293
Figure 6-21.	Flicker Filter and Line Buffer Path . . . . .	295
Figure 6-22.	Interlaced Timing Settings . . . . .	298
Figure 6-23.	Video Processor Block Diagram . . . . .	389
Figure 6-24.	Video Processor Block Diagram . . . . .	390
Figure 6-25.	Downscaler Block Diagram . . . . .	392
Figure 6-26.	Linear Interpolation Calculation . . . . .	393
Figure 6-27.	Mixer Block Diagram . . . . .	395
Figure 6-28.	Color Key and Alpha-Blending Logic . . . . .	396
Figure 6-29.	VOP Internal Block Diagram . . . . .	398
Figure 6-30.	525-Line NTSC Video Window . . . . .	399
Figure 6-31.	HBLANK and VBLANK for Lines 20-262, 283-524 . . . . .	399
Figure 6-32.	HBLANK and VBLANK for Lines 263, 525 . . . . .	400
Figure 6-33.	HBLANK and VBLANK for Lines 1-18, 264-281 . . . . .	400
Figure 6-34.	HBLANK and VBLANK for Lines 19, 282 . . . . .	400
Figure 6-35.	BT.656 8/16 Bit Line Data . . . . .	403
Figure 6-36.	Flat Panel Display Controller Block Diagram . . . . .	405
Figure 6-37.	Dithered 8x8 Pixel Pattern . . . . .	408
Figure 6-38.	N-Bit Dithering Pattern Schemes . . . . .	409
Figure 6-39.	VIP Block Diagram . . . . .	463
Figure 6-40.	BT.656, 8/16-Bit Line Data . . . . .	467
Figure 6-41.	525 line, 60 Hz Digital Vertical Timing . . . . .	468

Figure 6-42.	Ancillary Data Packets . . . . .	469
Figure 6-43.	Message Passing Data Packet . . . . .	470
Figure 6-44.	Data Streaming Data Packet . . . . .	470
Figure 6-45.	BT.601 Mode Default Field Detection . . . . .	471
Figure 6-46.	BT.601 Mode Programmable Field Detection . . . . .	472
Figure 6-47.	BT.601 Mode Horizontal Timing . . . . .	472
Figure 6-48.	BT.601 Mode Vertical Timing . . . . .	473
Figure 6-49.	YUV 4:2:2 to YUV 4:2:0 Translation . . . . .	474
Figure 6-50.	Dual Buffer for Message Passing and Data Streaming Modes . . . . .	476
Figure 6-51.	Example VIP YUV 4:2:2 SAV/EAV Packets Stored in System Memory in a Linear Buffer . . . . .	477
Figure 6-52.	Example VIP YUV 4:2:0 Planar Buffer . . . . .	478
Figure 6-53.	Example VIP 8/16- and 10-bit Ancillary Packets Stored in System Memory . . . . .	479
Figure 6-54.	Security Block Diagram . . . . .	510
Figure 6-55.	GLCP Block Diagram . . . . .	533
Figure 6-56.	Processor Clock Generation . . . . .	536
Figure 6-57.	GIO Interface Block Diagram . . . . .	537
Figure 6-58.	GLPCI Block Diagram . . . . .	566
Figure 6-59.	Atomic MSR Accesses Across the PCI Bus . . . . .	568
Figure 6-60.	Simple Round-Robin . . . . .	570
Figure 6-61.	Weighted Round-Robin . . . . .	570
Figure 7-1.	VMEMLX Power Split . . . . .	600
Figure 7-2.	Drive Level and Measurement Points for Switching Characteristics . . . . .	607
Figure 7-3.	Drive Level and Measurement Points for Switching Characteristics . . . . .	608
Figure 7-4.	Power Up Sequencing . . . . .	609
Figure 7-5.	Drive Level and Measurement Points for Switching Characteristics . . . . .	609
Figure 7-6.	Drive Level and Measurement Points for Switching Characteristics . . . . .	610
Figure 7-7.	Drive Level and Measurement Points for Switching Characteristics . . . . .	611
Figure 7-8.	DDR Write Timing Measurement Points . . . . .	615
Figure 7-9.	DDR Read Timing Measurement Points . . . . .	616
Figure 9-1.	BGU481 Top/Side View/Dimensions . . . . .	675
Figure 9-2.	BGU481 Bottom View/Dimensions . . . . .	676
Figure A-1.	AMD Geode™ LX Processors OPN Example . . . . .	677

# List of Tables

Table 2-1.	Graphics Processor Feature Comparison	17
Table 3-1.	Video Signal Definitions Per Mode	22
Table 3-2.	Buffer Type Characteristics	23
Table 3-3.	Bootstrap Options	24
Table 3-4.	Ball Type Definitions	24
Table 3-5.	Ball Assignments - Sorted by Ball Number	26
Table 3-6.	Ball Assignments - Sorted Alphabetically by Signal Name	30
Table 3-7.	Signal Behavior During and After Reset	43
Table 4-1.	MSR Addressing	45
Table 4-2.	MSR Mapping	47
Table 4-3.	GLIU Memory Descriptor Address Hit and Routing Description	48
Table 4-4.	GLIU I/O Descriptor Address Hit and Routing Description	49
Table 4-5.	GeodeLink™ Device Standard MSRs Summary	50
Table 4-6.	GLIU Specific MSRs Summary	50
Table 4-7.	GLIU Statistic and Comparator MSRs Summary	51
Table 4-8.	GLIU P2D Descriptor MSRs Summary	53
Table 4-9.	GLIU Reserved MSRs Summary	53
Table 4-10.	GLIU IOD Descriptor MSRs Summary	54
Table 5-1.	Initialized Core Register Controls	89
Table 5-2.	Application Register Set	91
Table 5-3.	Segment Register Selection Rules	92
Table 5-4.	EFLAGS Register	93
Table 5-5.	System Register Set	94
Table 5-6.	Control Registers Map	95
Table 5-7.	CR4 Bit Descriptions	96
Table 5-8.	CR3 Bit Descriptions	96
Table 5-9.	CR2 Bit Descriptions	96
Table 5-10.	CR0 Bit Descriptions	96
Table 5-11.	Effects of Various Combinations of EM, TS, and MP Bits	98
Table 5-12.	Standard GeodeLink™ Device MSRs Summary	99
Table 5-13.	CPU Core Specific MSRs Summary	99
Table 5-14.	XC_HIST_MSR Exception Types	126
Table 5-15.	Region Properties Register Map	170
Table 5-16.	Read Operations vs. Region Properties	170
Table 5-17.	Write Operations vs. Region Properties	170
Table 6-1.	LOI - 2 DIMMs, Same Size, 1 DIMM Bank	213
Table 6-2.	LOI - 2 DIMMs, Same Size, 2 DIMM Banks	213
Table 6-3.	Non-Auto LOI - 1 or 2 DIMMs, Different Sizes, 1 DIMM Bank	214
Table 6-4.	Non-Auto LOI - 1 or 2 DIMMs, Different Sizes, 2 DIMM Banks	214
Table 6-5.	Standard GeodeLink™ Device MSRs Summary	219
Table 6-6.	GLMC Specific MSR Summary	219
Table 6-7.	Graphics Processor Feature Comparison	238
Table 6-8.	BLT Command Buffer Structure	239
Table 6-9.	Vector Command Buffer Structure	240
Table 6-10.	LUT (Lookup Table) Load Command Buffer Structure	240

Table 6-11.	Data Only Command Buffer Structure . . . . .	240
Table 6-12.	Bit Descriptions . . . . .	241
Table 6-13.	Pixel Ordering for 4-Bit Pixels . . . . .	243
Table 6-14.	Example Vector Pattern . . . . .	244
Table 6-15.	Example Vector Length . . . . .	244
Table 6-16.	Example of Monochrome Pattern . . . . .	247
Table 6-17.	Example of 8-Bit Color Pattern (3:3:2 Format) . . . . .	248
Table 6-18.	Example of 16-Bit Color Pattern (5:6:5 Format) . . . . .	248
Table 6-19.	32-bpp 8:8:8:8 Color Data Format . . . . .	249
Table 6-20.	16-bpp Color Data Format . . . . .	249
Table 6-21.	8-bpp 3:3:2 Color Data Format . . . . .	249
Table 6-22.	Monochrome Data Format . . . . .	249
Table 6-23.	Example of Byte-Packed Monochrome Source Data . . . . .	250
Table 6-24.	Example of Unpacked Monochrome Source Data . . . . .	250
Table 6-25.	GP_RASTER_MODE Bit Patterns . . . . .	251
Table 6-26.	Common Raster Operations . . . . .	251
Table 6-27.	Alpha Blending Modes . . . . .	252
Table 6-28.	Standard GeodeLink™ Device MSRs Summary . . . . .	254
Table 6-29.	Graphics Processor Configuration Register Summary . . . . .	254
Table 6-30.	PAT_COLOR Usage for Color Patterns . . . . .	264
Table 6-31.	PAT_DATA Usage for Color Patterns . . . . .	265
Table 6-32.	Display Modes . . . . .	281
Table 6-33.	Cursor Display Encodings . . . . .	283
Table 6-34.	Icon Display Encodings . . . . .	283
Table 6-35.	Cursor/Color Key/Alpha Interaction . . . . .	284
Table 6-36.	Video Bandwidth . . . . .	286
Table 6-37.	YUV 4:2:0 Video Data Ordering . . . . .	287
Table 6-38.	YUV 4:2:2 Video Data Ordering . . . . .	287
Table 6-39.	VGA Text Modes . . . . .	288
Table 6-40.	Text Mode Attribute Byte Format . . . . .	288
Table 6-41.	VGA Graphics Modes . . . . .	288
Table 6-42.	Programming Image Sizes . . . . .	297
Table 6-43.	Vertical Timing in Number of Lines . . . . .	298
Table 6-44.	Timing Register Settings for Interlaced Modes . . . . .	299
Table 6-45.	Standard GeodeLink™ Device MSRs Summary . . . . .	300
Table 6-46.	DC Specific MSRs Summary . . . . .	300
Table 6-47.	DC Configuration Control Register Summary . . . . .	300
Table 6-48.	VGA Block Configuration Register Summary . . . . .	303
Table 6-49.	VGA Block Standard Register Summary . . . . .	303
Table 6-50.	VGA Block Extended Register Summary . . . . .	304
Table 6-51.	VGA Sequencer Registers Summary . . . . .	358
Table 6-52.	Font Table . . . . .	360
Table 6-53.	CRTC Register Settings . . . . .	361
Table 6-54.	CRTC Registers Summary . . . . .	362
Table 6-55.	CRTC Memory Addressing Modes . . . . .	371
Table 6-56.	Graphics Controller Registers Summary . . . . .	373
Table 6-57.	Attribute Controller Registers Summary . . . . .	378
Table 6-58.	Video DAC Registers Summary . . . . .	382
Table 6-59.	Extended Registers Summary . . . . .	384
Table 6-60.	Truth Table for Alpha-Blending . . . . .	397
Table 6-61.	VOP Mode . . . . .	401
Table 6-62.	SAV/EAV Sequence . . . . .	402
Table 6-63.	Protection Bit Values . . . . .	402
Table 6-64.	SAV VIP Flags . . . . .	404
Table 6-65.	VOP Clock Rate . . . . .	404



Table 6-66.	Panel Output Signal Mapping . . . . .	406
Table 6-67.	Register Settings for Dither Enable/Disable Feature . . . . .	410
Table 6-68.	Display RGB Modes . . . . .	411
Table 6-69.	Standard GeodeLink™ Device MSRs Summary . . . . .	412
Table 6-70.	Video Processor Module Specific MSRs Summary . . . . .	412
Table 6-71.	Video Processor Module Configuration Control Registers Summary . . . . .	412
Table 6-72.	VIP Capabilities . . . . .	462
Table 6-73.	SAV/EAV Sequence . . . . .	466
Table 6-74.	VIP Data Types / Memory Registers . . . . .	475
Table 6-75.	Standard GeodeLink™ Device MSRs Summary . . . . .	482
Table 6-76.	VIP Configuration/Control Registers Summary . . . . .	482
Table 6-77.	EEPROM Address Map . . . . .	512
Table 6-78.	Standard GeodeLink™ Device MSRs Summary . . . . .	513
Table 6-79.	Security Block Specific MSRs . . . . .	513
Table 6-80.	Security Block Configuration/Control Registers Summary . . . . .	513
Table 6-81.	TAP Control Instructions (25-Bit IR) . . . . .	534
Table 6-82.	TAP Instruction Bits . . . . .	534
Table 6-83.	GIO_PCI Outputs . . . . .	537
Table 6-84.	CIS Signaling Protocol . . . . .	538
Table 6-85.	Standard GeodeLink™ Device MSRs Summary . . . . .	539
Table 6-86.	GLCP Specific MSRs Summary . . . . .	539
Table 6-87.	Bootstrap Bit Settings and Reset State of GLCP_SYS_RSTPLL (PW1 and IRQ13 = 0) . . . . .	556
Table 6-88.	Bootstrap Bit Settings and Reset State of GLCP_SYS_RSTPLL (PW1 and IRQ13 vary) . . . . .	557
Table 6-89.	Format for Accessing the Internal PCI Configuration Registers . . . . .	569
Table 6-90.	PCI Device to AD Bus Mapping . . . . .	570
Table 6-91.	Standard GeodeLink™ Device MSRs Summary . . . . .	572
Table 6-92.	GLPCI Specific Registers Summary . . . . .	572
Table 6-93.	Region Properties . . . . .	586
Table 7-1.	Absolute Maximum Ratings . . . . .	597
Table 7-2.	Operating Conditions . . . . .	598
Table 7-3.	AMD Geode LX 900@1.5W Processor DC Currents . . . . .	600
Table 7-4.	AMD Geode LX 800@0.9W Processor DC Currents . . . . .	601
Table 7-5.	AMD Geode LX 700@0.8W Processor DC Currents . . . . .	602
Table 7-6.	AMD Geode LX 600@0.7W Processor DC Currents . . . . .	603
Table 7-7.	DC Characteristics . . . . .	604
Table 7-8.	System Interface Signals . . . . .	608
Table 7-9.	PCI Interface Signals . . . . .	609
Table 7-10.	VIP Interface Signals . . . . .	610
Table 7-11.	Flat Panel Interface Signals . . . . .	611
Table 7-12.	CRT Interface Signals . . . . .	612
Table 7-13.	CRT Display Recommended Operating Conditions . . . . .	612
Table 7-14.	CRT Display Analog (DAC) Characteristics . . . . .	613
Table 7-15.	Memory (DDR) Interface Signals . . . . .	614
Table 7-16.	JTAG Interface Signals . . . . .	617
Table 8-1.	General Instruction Set Format . . . . .	619
Table 8-2.	Instruction Fields . . . . .	620
Table 8-3.	Instruction Prefix Summary . . . . .	620
Table 8-4.	w Field Encoding . . . . .	621
Table 8-5.	d Field Encoding . . . . .	621
Table 8-6.	s Field Encoding . . . . .	621
Table 8-7.	eee Field Encoding . . . . .	622
Table 8-8.	mod r/m Field Encoding . . . . .	622
Table 8-9.	General Registers Selected by mod r/m Fields and w Field . . . . .	623
Table 8-10.	reg Field . . . . .	624
Table 8-11.	sreg2 Field Encoding . . . . .	624

Table 8-12.	sreg3 Field (FS and GS Segment Register Selection) . . . . .	624
Table 8-13.	ss Field Encoding . . . . .	625
Table 8-14.	index Field Encoding . . . . .	625
Table 8-15.	mod base Field Encoding . . . . .	626
Table 8-16.	CPUID Instruction with EAX = 0000000h . . . . .	627
Table 8-17.	CPUID Instruction with EAX = 0000001h . . . . .	627
Table 8-18.	CPUID Instruction Codes with EAX = 0000000 . . . . .	628
Table 8-19.	CPUID Instruction with EAX = 8000000h . . . . .	629
Table 8-20.	CPUID Instruction with EAX = 8000001h . . . . .	629
Table 8-21.	CPUID Instruction Codes with EAX = 8000001h . . . . .	630
Table 8-22.	CPUID Instruction with EAX = 8000002h, 8000003h, or 8000004h . . . . .	631
Table 8-23.	CPUID Instruction with EAX = 8000005h . . . . .	632
Table 8-24.	CPUID Instruction with EAX = 8000006h . . . . .	632
Table 8-25.	Processor Core Instruction Set Table Legend . . . . .	633
Table 8-26.	Processor Core Instruction Set . . . . .	634
Table 8-27.	MMX™, FPU, and AMD 3DNow!™ Instruction Set Table Legend . . . . .	658
Table 8-28.	MMX™ Instruction Set . . . . .	660
Table 8-29.	FPU Instruction Set . . . . .	667
Table 8-30.	AMD 3DNow!™ Technology Instruction Set . . . . .	671
Table A-1.	Valid OPN Combinations . . . . .	678
Table A-2.	Revision History . . . . .	679
Table A-3.	Edits to Current Revision . . . . .	679

# 1 Overview

## 1.1 General Description

AMD Geode™ LX processors are integrated x86 processors specifically designed to power embedded devices for entertainment, education, and business. Serving the needs of consumers and business professionals alike, it's an excellent solution for embedded applications, such as thin clients, interactive set-top boxes, single board computers, and mobile computing devices.

Available with a core voltage of 1.2V, 1.25V, or 1.4V it offers extremely low typical power consumption leading to longer battery life and enabling small form-factor, fanless designs.

While the processor core provides maximum compatibility with the vast amount of Internet content available, the intelligent integration of several other functions, including graphics and video datapaths, offers a true system-level multimedia solution.

For implementation details and suggestions for this device, see the supporting documentation (i.e., application notes, schematics, etc.) on the AMD Embedded Developer Support Web site (<http://wwwd.amd.com/dev>, NDA required).

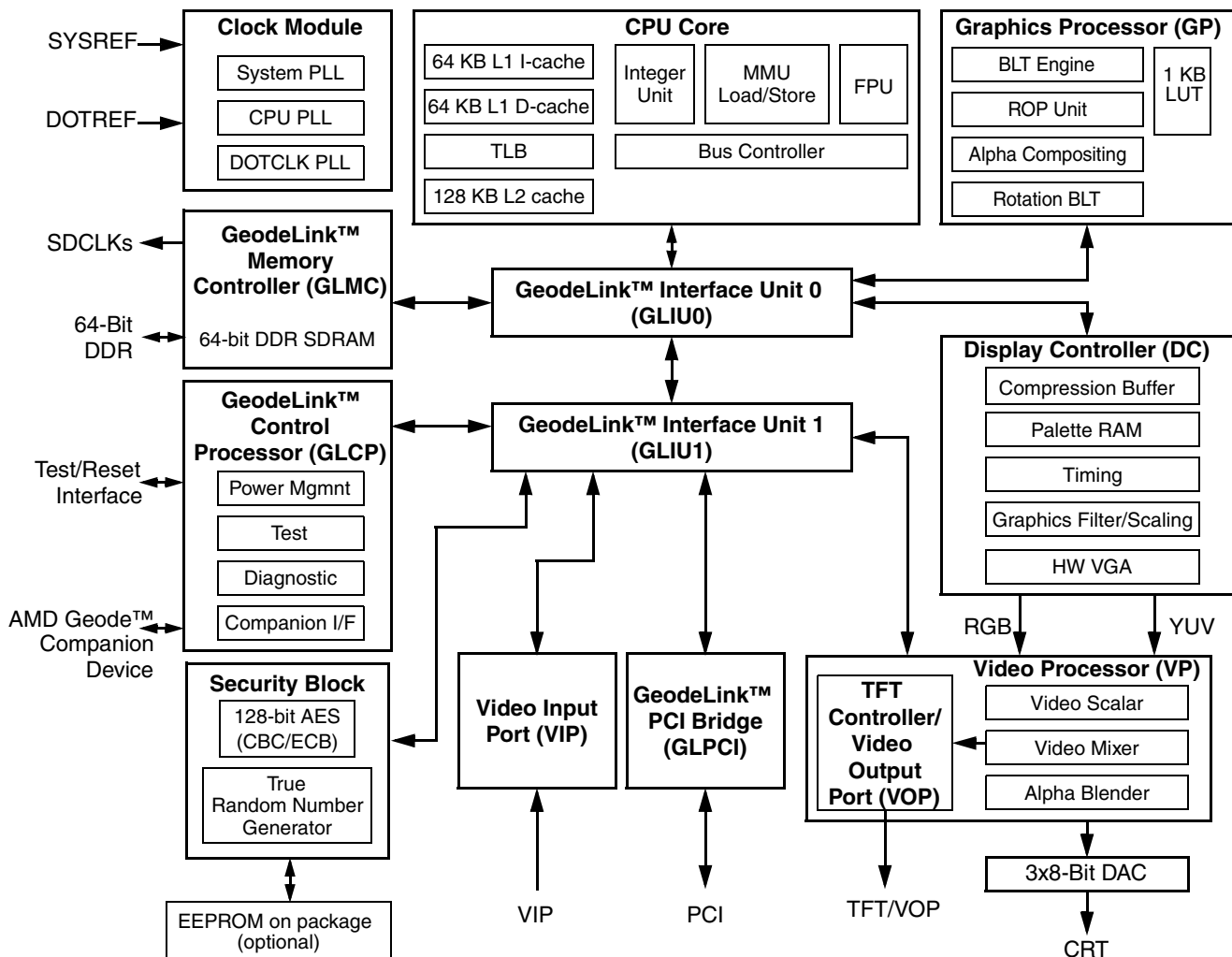


Figure 1-1. Internal Block Diagram

## 1.2 Features

### General Features

- Functional blocks include:
  - CPU Core
  - GeodeLink™ Control Processor
  - GeodeLink Interface Units
  - GeodeLink Memory Controller
  - Graphics Processor
  - Display Controller
  - Video Processor
    - TFT Controller/Video Output Port
  - Video Input Port
  - GeodeLink PCI Bridge
  - Security Block
- 0.13 micron process
- Packaging:
  - 481-Terminal BGA (Ball Grid Array Cavity Up) with internal heatspreader
- Single packaging option supports all features
- Industrial temperature range available for the LX 800@0.9W processor\*

### CPU Processor Features

- x86/x87-compatible CPU core
- Performance:
  - Processor frequency: up to 600 MHz
  - Dhrystone 2.1 MIPs: 150 to 450
  - Fully pipelined FPU
- Split I/D cache/TLB (Translation Look-aside Buffer):
  - 64 KB I-cache/64 KB D-cache
  - 128 KB L2 cache configurable as I-cache, D-cache, or both
- Efficient prefetch and branch prediction
- Integrated FPU that supports the MMX™ and AMD 3DNow!™ instruction sets
- Fully pipelined single precision FPU hardware with microcode support for higher precisions

### GeodeLink™ Control Processor

- JTAG interface:
  - ATPG, Full Scan, BIST on all arrays
  - 1149.1 Boundary Scan compliant
- ICE (in-circuit emulator) interface
- Reset and clock control
- Designed for improved software debug methods and performance analysis

- Power Management:
  - LX 900@1.5W processor\* (Unterminated):
    - Total Dissipated Power (TDP) 5.1W, 2.6W typical @ 600 MHz max power
  - LX 800@0.9W processor\* (Unterminated):
    - Total Dissipated Power (TDP) 3.6W, 1.8W typical @ 500 MHz max power
  - LX 700@0.8W processor\* (Unterminated):
    - Total Dissipated Power (TDP) 3.1W, 1.3W typical @ 433 MHz max power
  - LX 600@0.7W processor\* (Unterminated):
    - Total Dissipated Power (TDP) 2.8W, 1.2W typical @ 366 MHz max power
  - GeodeLink active hardware power management
  - Hardware support for standard ACPI software power management
  - I/O companion SUSP/SUSPA power controls
  - Lower power I/O
  - Wakeup on SMI/INTR
- Works in conjunction with the AMD Geode™ CS5536 (USB 2.0) or CS5535 (USB 1.1) companion device

### GeodeLink™ Architecture

- High bandwidth packetized uni-directional bus for internal peripherals
- Standardized protocol to allow variants of products to be developed by adding or removing modules
- GeodeLink Control Processor (GLCP) for diagnostics and scan control
- Dual GeodeLink Interface Units (GLIUs) for device interconnect

### GeodeLink™ Memory Controller

- Integrated memory controller for low latency to CPU and on-chip peripherals
- 64-bit wide DDR SDRAM bus operating frequency:
  - 200 MHz, 400 MT/S
- Supports unbuffered DDR DIMMS using up to 2 GB DRAM technology
- Supports up to 2 DIMMS (16 devices max)

### 2D Graphics Processor

- High performance 2D graphics controller
- Alpha BLT
- Windows® GDI GUI acceleration:
  - Hardware support for all Microsoft RDP codes
- Command buffer interface for asynchronous BLTs
- Second pattern channel support
- Hardware screen rotation

\*The AMD Geode LX 900@1.5W processor operates at 600 MHz, the AMD Geode LX 800@0.9W processor operates at 500 MHz, the AMD Geode LX 700@0.8W processor operates at 433 MHz and the AMD Geode LX 600@.07W processor operates at 366 MHz. Model numbers reflect performance as described here: <http://www.amd.com/connectivitysolutions/geodelxbenchmark>.

### Display Controller

- Hardware frame buffer compression improves Unified Memory Architecture (UMA) memory efficiency
- CRT resolutions supported:
  - Supports up to 1920x1440x32 bpp at 85 Hz
  - Supports up to 1600x1200x32 bpp at 100 Hz
- Supports up to 1600x1200x32 bpp at 60 Hz for TFT
- Standard Definition (SD) resolution for Video Output Port (VOP):
  - 720x482 at 59.94 Hz interlaced for NTSC
  - 768x576 at 50 Hz interlaced for PAL
- High Definition (HD) resolution for Video Output Port (VOP):
  - Up to 1920x1080 at 30 Hz interlaced (1080i HD) (74.25 MHz)
  - Up to 1280x720 at 60 Hz progressive (720p HD) (74.25 MHz)
- Supports down to 7.652 MHz Dot Clock (320x240 QVGA)
- Hardware VGA
- Hardware supported 48x64 32-bit cursor with alpha blending

### Video Processor

- Supports video scaling, mixing and VOP
- Hardware video up/down scalar
- Graphics/video alpha blending and color key muxing
- Digital VOP (SD and HD) or TFT outputs
- Legacy RGB mode
- VOP supports SD and HD 480p, 480i, 720p, and 1080i
- VESA 1.1, 2.0 and BT.601 24-bit (out only), BT.656 compliant

### Integrated Analog CRT DAC, System Clock PLLs and Dot Clock PLL

- Integrated Dot Clock PLL with up to 350 MHz clock
- Integrated 3x8-bit DAC with up to 350 MHz sampling
- Integrated x86 core PLL
- Memory PLL

### GeodeLink™ PCI Bridge

- PCI 2.2 compliant
- 3.3V signaling and 3.3V I/Os
- 33 to 66 MHz operation
- 32-bit interface
- Supports virtual PCI headers for GeodeLink devices

### Video Input Port (VIP)

- VESA 1.1 and 2.0 compliant, 8 or 16-bit
- Video Blanking Interval (VBI) support
- 8 or 16-bit 80 MHz SD or HD capable

### Security Block

- Serial EEPROM interface for 2K bit unique ID and AES (Advanced Encryption Standard) hidden key storage (EEPROM optional inside package)
- Electronic Code Book (ECB) or Cipher Block Chaining (CBC) 128-bit AES hardware support
- True random number generator (TRNG)



# Architecture Overview

# 2

The CPU Core provides maximum compatibility with the vast amount of Internet content available while the intelligent integration of several other functions, including graphics, makes the AMD Geode™ LX processor a true system-level multimedia solution.

The AMD Geode LX processor can be divided into major functional blocks (as shown in Figure 1-1 on page 11):

- CPU Core
- GeodeLink™ Control Processor
- GeodeLink Interface Units
- GeodeLink Memory Controller
- Graphics Processor
- Display Controller
- Video Processor
  - TFT Controller/Video Output Port
- Video Input Port
- GeodeLink PCI Bridge
- Security Block

## 2.1 CPU Core

The x86 core consists of an Integer Unit, cache memory subsystem, and an x87 compatible FPU (Floating Point Unit). The Integer Unit contains the instruction pipeline and associated logic. The memory subsystem contains the instruction and data caches, translation look-aside buffers (TLBs), and an interface to the GeodeLink Interface Units (GLIUs).

The instruction set supported by the core is a combination of Intel Pentium® processor, AMD Athlon™ processor, and AMD Geode LX processor specific instructions. Specifically, it supports the Pentium, Pentium Pro, AMD 3DNow!™ technology and MMX™ instructions for the AMD Athlon processor. It supports a subset of the specialized AMD Geode LX processor instructions including special SMM instructions. The CPU Core does not support the entire Katmai New Instruction (KNI) set as implemented in the Pentium 3. It does support the MMX instructions for the AMD Athlon processor, which are a subset of the Pentium 3 KNI instructions.

### 2.1.1 Integer Unit

The Integer Unit consists of a single issue 8-stage pipeline and all the necessary support hardware to keep the pipeline running efficiently.

The instruction pipeline in the integer unit consists of eight stages:

- 1) **Instruction Prefetch** - Raw instruction data is fetched from the instruction memory cache.
- 2) **Instruction Pre-decode** - Prefix bytes are extracted from raw instruction data. This decode looks-ahead to the next instruction and the bubble can be squashed if the pipeline stalls down stream.
- 3) **Instruction Decode** - Performs full decode of instruction data. Indicates instruction length back to the Prefetch Unit, allowing the Prefetch Unit to shift the appropriate number of bytes to the beginning of the next instruction.
- 4) **Instruction Queue** - FIFO containing decoded x86 instructions. Allows Instruction Decode to proceed even if the pipeline is stalled downstream. Register reads for data operand address calculations are performed during this stage.
- 5) **Address Calculation #1** - Computes linear address of operand data (if required) and issues request to the Data Memory Cache. Microcode can take over the pipeline and inject a micro-box here if multi-box instructions require additional data operands.
- 6) **Address Calculation #2** - Operand data (if required) is returned and set up to the Execution stage with no bubbles if there was a data cache hit. Segment limit checking is performed on the data operand address. The μROM is read for setup to Execution Unit.
- 7) **Execution Unit** - Register and/or data memory fetched through the Arithmetic Logic Unit (ALU) for arithmetic or logical operations. μROM always fires for the first instruction box down the pipeline. Microcode can take over the pipeline and insert additional boxes here if the instruction requires multiple Execution Unit stages to complete.
- 8) **Writeback** - Results of the Execution Unit stages are written to the register file or to data memory.

### 2.1.2 Memory Management Unit

The memory management unit (MMU) translates the linear address supplied by the integer unit into a physical address to be used by the cache unit and the internal bus interface unit. Memory management procedures are x86-compatible, adhering to standard paging mechanisms.

The MMU also contains a load/store unit that is responsible for scheduling cache and external memory accesses. The load/store unit incorporates two performance-enhancing features:

- **Load-store reordering** gives memory reads required by the integer unit a priority over writes to external memory.
- **Memory-read bypassing** eliminates unnecessary memory reads by using valid data from the execution unit.

### 2.1.3 Cache and TLB Subsystem

The cache and TLB subsystem of the CPU Core supplies the integer pipeline with instructions, data, and translated addresses (when necessary). To support the efficient delivery of instructions, the cache and TLB subsystem has a single clock access 64 KB 16-way set associative instruction cache and a 16-entry fully associative TLB. The TLB performs necessary address translations when in protected mode. For data, there is a 64 KB 16-way set associative writeback cache, and a 16-entry fully associative TLB. When there is a miss to the instruction or data TLBs, there is a second level unified (instruction and data) 64-entry 2-way set associative TLB that takes an additional clock to access. When there is a miss to the instruction or data caches or the TLB, the access must go to the GeodeLink Memory Controller (GLMC) for processing. Having both an instruction and a data cache and their associated TLBs improves overall efficiency of the integer unit by enabling simultaneous access to both caches.

The L1 caches are supported by a 128 KB unified L2 victim cache. The L2 cache can be configured to hold data, instructions, or both. The L2 cache is 4-way set associative.

### 2.1.4 Bus Controller Unit

The bus controller unit provides a bridge from the processor to the GLIUs. When external memory access is required, due to a cache miss, the physical address is passed to the bus controller unit, that translates the cycle to a GeodeLink cycle.

### 2.1.5 Floating Point Unit

The Floating Point Unit (FPU) is a pipelined arithmetic unit that performs floating point operations as per the IEEE 754 standard. The instruction sets supported are x87, MMX, and AMD 3DNow! technology. The FPU is a pipelined machine with dynamic scheduling of instructions to minimize stalls due to data dependencies. It performs out of order execution and register renaming. It is designed to support an instruction issue rate of one per clock from the

integer core. The datapath is optimized for single precision arithmetic. Extended precision instructions are handled in microcode and require multiple passes through the pipeline. There is an execution pipeline and a load/store pipeline. This allows load/store operations to execute in parallel with arithmetic instructions.

## 2.2 GeodeLink™ Control Processor

The GeodeLink Control Processor (GLCP) is responsible for reset control, macro clock management, and debug support provided in the Geode LX processor. It contains the JTAG interface and the scan chain control logic. It supports chip reset, including initial PLL control and programming and runtime power management macro clock control.

The JTAG support includes a TAP Controller that is IEEE 1149.1 compliant. CPU control can be obtained through the JTAG interface into the TAP Controller, and all internal registers, including CPU Core registers, can be accessed. In-circuit emulation (ICE) capabilities are supported through this JTAG and TAP Controller interface.

The GLCP also includes the companion device interface. The companion device has several unique signals connected to this module that support Geode LX processor reset, interrupts, and system power management.

## 2.3 GeodeLink™ Interface Units

Together, the two GeodeLink Interface Units (GLIU0 and GLIU1) make up the internal bus derived from the GeodeLink architecture. GLIU0 connects five high bandwidth modules together with a seventh link to GLIU1 that connects to the five low bandwidth modules.

## 2.4 GeodeLink™ Memory Controller

The GeodeLink Memory Controller (GLMC) is the source for all memory needs in a typical Geode LX processor system. The GLMC supports a memory data bus width of 64 bits and supports 200 MHz, 400 MT/S for DDR (Double Data Rate).

The modules that need memory are the CPU Core, Graphics Processor, Display Controller, Video Input Port, and Security Block. Because the GLMC supports memory needs for both the CPU Core and the display subsystem, the GLMC is classically called a UMA (Unified Memory Architecture) subsystem. PCI accesses to main memory are also supported.

Up to four banks, with eight devices maximum in each bank of SDRAM, are supported with up to 512 MB in each bank. Four banks means that one or two DIMM or SODIMM modules can be used in a AMD Geode LX processor system. Some memory configurations have additional restrictions on maximum device quantity.



## 2.5 Graphics Processor

The Graphics Processor is based on the graphics processor used in the AMD Geode GX processor with several features added to enhance performance and functionality. Like its predecessor, the AMD Geode LX processor's Graphics Processor is a BitBLT/vector engine that supports pattern generation, source expansion, pattern/source transparency, 256 ternary raster operations, alpha blenders to support alpha-BLTs, incorporated BLT FIFOs, a GeodeLink interface and the ability to throttle BLTs according to video timing. Features added to the Graphics Processor include:

- Command buffer interface

- Hardware accelerated rotation BLTs
- Color depth conversion
- Paletized color
- Full 8x8 color pattern buffer
- Channel 3 - third DMA channel
- Monochrome inversion

Table 2-1 presents a comparison between the Graphics Processor features of the AMD Geode GX and LX processors.

**Table 2-1. Graphics Processor Feature Comparison**

Feature	AMD Geode™ GX Processor	AMD Geode™ LX Processor
Color Depth	8, 16, 32 bpp	8, 16, 32 bpp (A) RGB 4 and 8-bit indexed
ROPs	256 (src, dest, pattern)	256 (2-src, dest and pattern)
BLT Buffers	FIFOs in Graphics Processor	FIFOs in Graphics Processor
BLT Splitting	Managed by hardware	Managed by hardware
Video Synchronized BLT/Vector	Throttle by VBLANK	Throttle by VBLANK
Bresenham Lines	Yes	Yes
Patterned (stippled) Lines	No	Yes
Screen to Screen BLT	Yes	Yes
Screen to Screen BLT with mono expansion	Yes	Yes
Memory to Screen BLT	Yes (through CPU writes)	Yes (throttled rep movs writes)
Accelerated Text	No	No
Pattern Size (Mono)	8x8 pixels	8x8 pixels
Pattern Size (Color)	8x1 (32 pixels) 8x2 (16 pixels) 8x4 (8 pixels)	8x8 pixels
Monochrome Pattern	Yes	Yes (with inversion)
Dithered Pattern (4 color)	No	No
Color Pattern	8, 16, 32 bpp	8, 16, 32 bpp
Transparent Pattern	Monochrome	Monochrome
Solid Fill	Yes	Yes
Pattern Fill	Yes	Yes
Transparent Source	Monochrome	Monochrome
Color Key Source Transparency	Y with mask	Y with mask
Variable Source Stride	Yes	Yes
Variable Destination Stride	Yes	Yes
Destination Write Bursting	Yes	Yes
Selectable BLT Direction	Vertical and Horizontal	Vertical and Horizontal
Alpha BLT	Yes (constant $\alpha$ or $\alpha/\text{pix}$ )	Yes (constant $\alpha$ , $\alpha/\text{pix}$ , or sep. $\alpha$ channel)
VGA Support	Decodes VGA Register	Decodes VGA Register
Pipeline Depth	2 ops	Unlimited
Accelerated Rotation BLT	No	8, 16, 32 bpp
Color Depth Conversion	No	5:6:5, 1:5:5:5, 4:4:4:4, 8:8:8:8

## 2.6 Display Controller

The Display Controller performs the following functions:

- 1) Retrieves graphics, video, and cursor data.
- 2) Serializes the streams.
- 3) Performs any necessary color lookups and output formatting.
- 4) Interfaces to the Video Processor for driving the display device(s).

The Display Controller consists of a memory retrieval system for rasterized graphics data, a VGA, and a back-end filter. The AMD Geode LX processor's Display Controller corresponds to the Display Controller function found in the AMD Geode GX processor with additional hardware for graphics filter functions. The VGA provides full hardware compatibility with the VGA graphics standard. The rasterized graphics and the VGA share a single display FIFO and display refresh memory interface to the GeodeLink Memory Controller (GLMC). The VGA uses 8 bpp and syncs, that are expanded to 24 bpp via the color lookup table, and passes the information to the graphics filter for scaling and interlaced display support. The stream is then passed to the Video Processor, which is used for video overlay. The Video Processor forwards this information to the DAC (Digital-to-Analog Converter), that generates the analog red, green, and blue signals, and buffers the sync signals that are then sent to the display. The Video Processor output can also be rendered as YUV data, and can be output on the Video Output Port (VOP).

## 2.7 Video Processor

The Video Processor mixes the graphics and video streams, and outputs either digital RGB data to the internal DACs or the flat panel interface, or digital YUV data via the VOP interface.

The Video Processor delivers high-resolution and true-color graphics. It can also overlay or blend a scaled true-color video image on the graphic background.

The Video Processor interfaces with the CPU Core via a GLIU master/slave interface. The Video Processor is a slave only, as it has no memory requirements.

### 2.7.1 CRT Interface

The internal high performance DACs support CRT resolutions up to:

- 1920x1440x32 bpp at 85 Hz
- 1600x1200x32 bpp at 100 Hz

### 2.7.2 TFT Controller

The TFT Controller converts the digital RGB output of a Video Mixer block to the digital output suitable for driving a TFT flat panel LCD.

The flat panel connects to the RGB port of the Video Mixer. It interfaces directly to industry standard 18-bit or 24-bit active matrix thin film transistor (TFT). The digital RGB or video data that is supplied by the video logic is converted into a suitable format to drive a wide range of panels with variable bits. The LCD interface includes dithering logic to increase the apparent number of colors displayed for use on panels with less than 6 bits per color. The LCD interface also supports automatic power sequencing of panel power supplies.

It supports panels up to a 24-bit interface and up to 1600x1200 resolution.

The TFT Controller interfaces with the CPU Core via a GLIU master/slave interface. The TFT Controller is both a GLIU master and slave.

### 2.7.3 Video Output Port

The VOP receives YUV 4:4:4 encoded data from the Video Processor and formats the data into a video stream that is BT.656 compliant. Output from the VOP goes to either a VIP or a TV encoder. The VOP is BT.656/601 compliant since its output may go directly (or indirectly) to a display.

## 2.8 Video Input Port

The Video Input Port (VIP) receives 8- or 16-bit video or ancillary data, 8-bit message data, or 8-bit raw video and passes it to data buffers located in system memory. The VIP is a DMA engine. The primary operational mode is as a compliant VESA 2.0 slave. The VESA 2.0 specification defines the protocol for receiving video, VBI, and ancillary data. The addition of the message passing and data streaming modes provides additional flexibility in receiving non-VESA 2.0 compliant data streams. Input data is packed into QWORDS, buffered into a FIFO, and sent to system memory over the GLIU. The VIP masters the internal GLIU and transfers the data from the FIFO to system memory. The maximum input data rate (8- or 16-bits) is 150 MHz.

## 2.9 GeodeLink™ PCI Bridge

The GeodeLink PCI Bridge (GLPCI) contains all the necessary logic to support an external PCI interface. The PCI interface is PCI v2.2 specification compliant. The logic includes the PCI and GLIU interface control, read and write FIFOs, and a PCI arbiter.

## 2.10 Security Block

The AMD Geode LX processor has an on-chip AES 128-bit crypto acceleration block capable of 44 Mbps throughput on either encryption or decryption at a processor speed of 500 MHz. The AES block runs asynchronously to the processor core and is DMA based. The AES block supports both EBC and CBC modes and has an interface for accessing the optional EEPROM memory for storing unique IDs and/or security keys. The AES and EEPROM sections have separate control registers but share a single

set of interrupt registers. The AES module has two key sources: one hidden 128-bit key stored in the “on-package” EEPROM, and a write only 128-bit key (reads as all zeros). The hidden key is loaded automatically by the hardware after reset and is not visible to the processor. The EEPROM can be locked. The initialization vector for the CBC mode can be generated by the True Random Number Generator (TRNG). The TRNG is addressable separately and generates a 32-bit random number.



# Signal Definitions

## 3

This chapter defines the signals and describes the external interface of the AMD Geode™ LX processor. Figure 3-1 shows the pins organized by their functional groupings. Where signals are multiplexed, the default signal name is listed first and is separated by a plus sign (+). Multi-function pins are described in Table 3-1 on page 22.

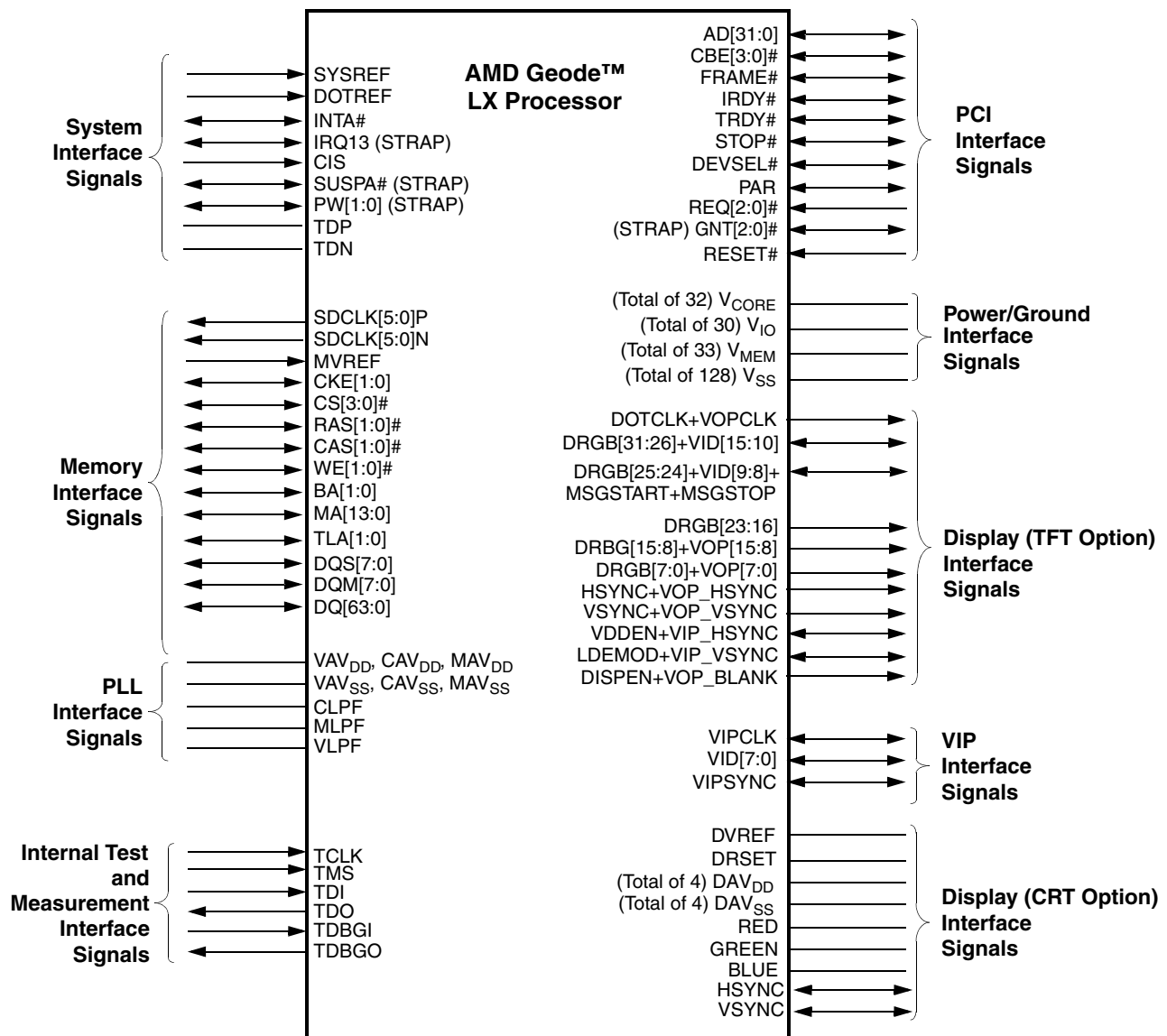


Figure 3-1. Signal Groups

Table 3-1. Video Signal Definitions Per Mode

Signal Name	CRT w/16-bit VIP	RGB w/16-bit VIP	ARGB (Note 1) w/8-bit VIP	TFT w/16-bit VIP (not 601)	8- or 16-bit VOP w/16-bit VIP
RED	RED				
GREEN	GREEN				
BLUE	BLUE				
DRGB[31:24] (I/O)	VID[15:8] (I)	VID[15:8] (I)	Alpha	VID[15:8] (I)	VID[15:8] (I)
DRGB[23:16] (O)	R[7:0]	R[7:0]	R[7:0]	R[7:0] (Note 2)	Driven low
DRGB[15:8] (O)	G[7:0]	G[7:0]	G[7:0]	G[7:0] (Note 2)	VOP[15:8] (O)
DRGB[7:0] (O)	B[7:0]	B[7:0]	B[7:0]	B[7:0] (Note 2)	VOP[7:0] (O)
DOTCLK (O)	DOTCLK (O)	DOTCLK (O)	DOTCLK (O)	DOTCLK (O)	VOPCLK (O)
HSYNC (O)	HSYNC (O)	HSYNC (O)	HSYNC (O)	VOP_HSYNC (O)	VOP_HSYNC (O)
VSYNC (O)	VSYNC (O)	VSYNC (O)	VSYNC (O)	VSYNC (O)	VOP_VSYNC (O)
DISPEN (O)				DISPEN (O)	VOP_BLANK (O)
VDDEN (I/O)	VIP_HSYNC (I)	VIP_HSYNC (I)	VIP_HSYNC (I)	VDDEN (O)	VIP_HSYNC (I)
LDEMOD (I/O)	VIP_VSYNC (I)	VIP_VSYNC (I)	VIP_VSYNC (I)	LDEMOD (O)	VIP_VSYNC (I)
VID[7:0] (I)	VID[7:0]	VID[7:0]	VID[7:0]	VID[7:0]	VID[7:0]
VIPCLK (I)	VIPCLK	VIPCLK	VIPCLK	VIPCLK	VIPCLK
VIPSYNC (I)	VIPSYNC	VIPSYNC	VIPSYNC	VIPSYNC	VIPSYNC

Note 1. Alpha RED/GREEN/BLUE: Useful for off-chip graphics digital interfaces.

Note 2. Pin usage depends on TFT mode. See Section 6.7.7 "Flat Panel Display Controller" on page 405 for details.

### 3.1 Buffer Types

The Ball Assignment tables starting on page 26 include a column labeled “Buffer Type”. The details of each buffer type listed in this column are given in Table 3-2. The column headings in Table 3-2 are identified as follows:

**TS:** Indicates whether the buffer may be put into the TRI-STATE mode. Note some pins that have buffer types that allow TRI-STATE may never actually enter the TRI-STATE mode in practice, since they may be inputs or provide other signals that are always driven. To determine if a particular signal can be put in the TRI-STATE mode, consult the individual signal descriptions in Section 3.4 “Signal Descriptions” on page 33.

**OD:** Indicates if the buffer is open-drain, or not. Open-drain outputs may be wire ORed together and require a discrete pull-up resistor to operate properly.

**5VT:** Indicates if the buffer is 5-volt tolerant, or not. If it is 5-volt tolerant, then 5 volt TTL signals may be safely applied to this pin.

**PU/PD:** Indicates if an internal, programmable pull-up or pull-down resistor may be present.

**Current High/Low (mA):** This column gives the current source/sink capacities when the voltage at the pin is high, and low. The high and low values are separated by a “/” and values given are in milli-amps (mA).

**Rise/Fall @ Load:** This column indicates the rise and fall times for the different buffer types at the load capacitance indicated. These measurements are given in two ways: rise/fall time between the 20%-80% voltage levels, or, the rate of change the buffer is capable of, in volts-per-nano-second (V/ns).

Note the presence of “Wire” type buffer in this table. Signals identified as a wire-type are not driven by a buffer, hence no rise/fall time or other measurements are given; these are marked “NA” in Table 3-2. The wire-type connection indicates a direct connection to internal circuits such as power, ground, and analog signals.

**Table 3-2. Buffer Type Characteristics**

Name	TS	OD	5VT	PU/PD	Current High/Low (mA)	Rise/Fall @ Load
24/Q3	X			X	24/24	3 ns @ 50 pF
24/Q5	X			X	24/24	5 ns @ 50 pF
24/Q7	X			X	24/24	7 ns @ 50 pF
5V	X		X		16/16	1.25V/ns @ 40 pF
PCI	X				0.5/1.5	1-4V/ns @ 10 pF
DDRCLK					10/10	8.5V/ns @ 15 pF
DDR						2.4V/ns @ 50 pF
Wire	NA	NA		NA	NA	NA

### 3.2 Bootstrap Options

The bootstrap options shown in Table 3-3 are supported in the AMD Geode LX processor for configuring the system.

**Table 3-3. Bootstrap Options**

Pins	Description
IRQ13	0: Normal boot operation, TAP reset active during PCI reset 1: Debug stall of CPU after CPU reset, TAP reset active until $V_{IO}$ valid
PW1	0: PCI (SYSREF) is 33 MHz 1: PCI (SYSREF) is 66 MHz
PW0, SUSPA#, GNT[2:0]#	Select CPU and GeodeLink system MHz options including a PLL bypass option. Refer to Table 6-87 on page 556 for programming.

### 3.3 Ball Assignments

The tables in this chapter use several common abbreviations. Table 3-4 lists the mnemonics and their meanings.

**Table 3-4. Ball Type Definitions**

Mnemonic	Definition
A	Analog
I	Input ball
I/O	Bidirectional ball
CAV <sub>SS</sub>	Core PLL Ground ball: Analog
CAV <sub>DD</sub>	Core PLL Power ball: Analog
DAV <sub>SS</sub>	DAC PLL Ground ball: Analog
DAV <sub>DD</sub>	DAC PLL Power ball: Analog
MAV <sub>SS</sub>	GLIU PLL Ground ball: Analog
MAV <sub>DD</sub>	GLIU PLL Power ball: Analog
O	Output ball
VAV <sub>SS</sub>	Video PLL Ground ball: Analog
VAV <sub>DD</sub>	Video PLL Power ball: Analog
V <sub>CORE</sub>	Power ball: 1.2V (Nominal)
V <sub>IO</sub>	I/O Power ball: 3.3V (Nominal)
V <sub>MEM</sub>	Power ball: 2.5V
V <sub>SS</sub>	Ground ball
#	The “#” symbol at the end of a signal name indicates that the active, or asserted state, occurs when the signal is at a low voltage level. When “#” is not present after the signal name, the signal is asserted when at a high voltage level.



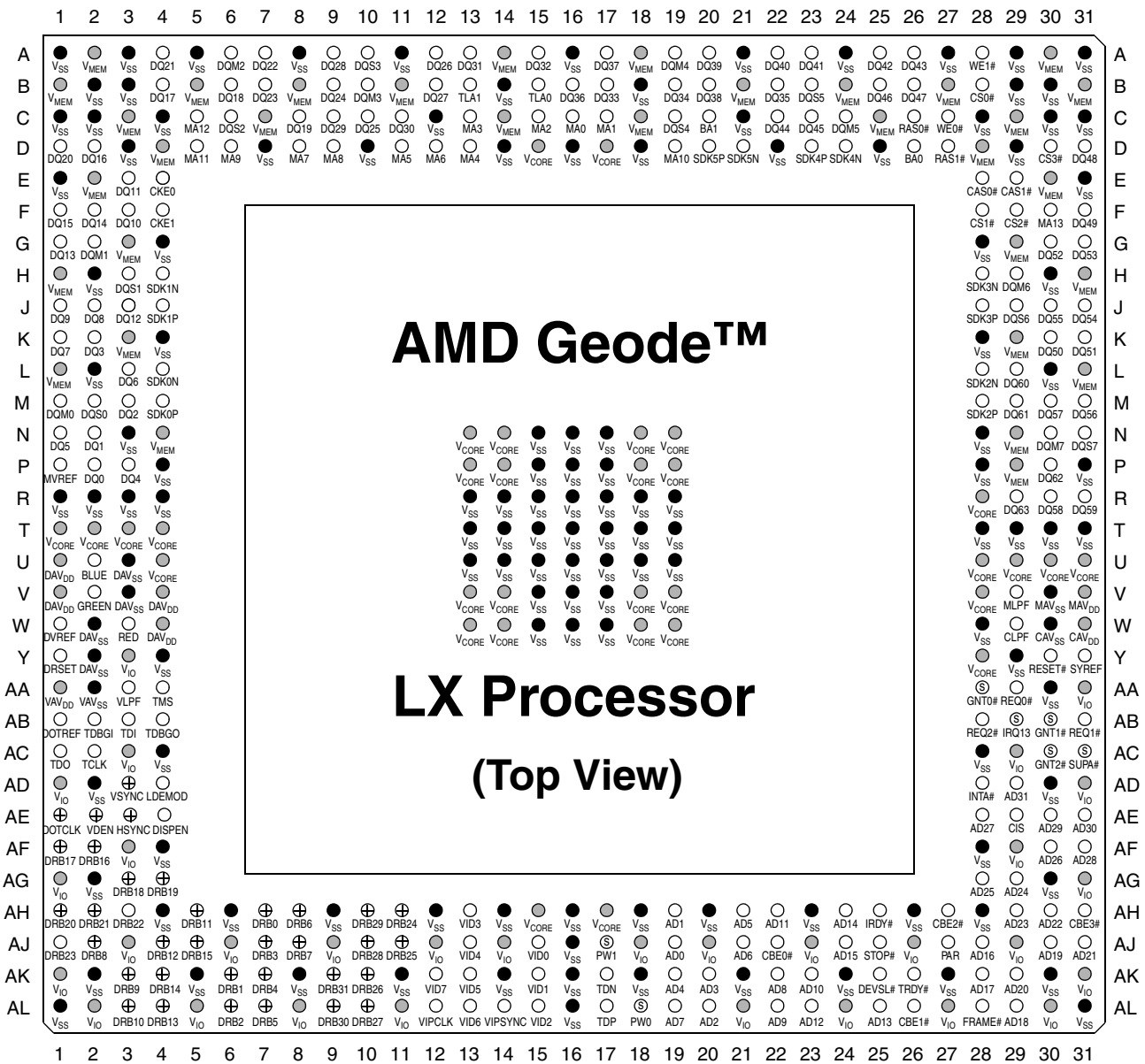


Figure 3-2. BGU481 Ball Assignment Diagram

Table 3-5. Ball Assignments - Sorted by Ball Number

Ball No.	Signal Name (Note 1)	Type (PD)	Buffer Type
A1	V <sub>SS</sub>	GND	---
A2	V <sub>MEM</sub>	PWR	---
A3	V <sub>SS</sub>	GND	---
A4	DQ21	I/O	DDR
A5	V <sub>SS</sub>	GND	---
A6	DQM2	I/O	DDR
A7	DQ22	I/O	DDR
A8	V <sub>SS</sub>	GND	---
A9	DQ28	I/O	DDR
A10	DQS3	I/O	DDR
A11	V <sub>SS</sub>	GND	---
A12	DQ26	I/O	DDR
A13	DQ31	I/O	DDR
A14	V <sub>MEM</sub>	PWR	---
A15	DQ32	I/O	DDR
A16	V <sub>SS</sub>	GND	---
A17	DQ37	I/O	DDR
A18	V <sub>MEM</sub>	PWR	---
A19	DQM4	I/O	DDR
A20	DQ39	I/O	DDR
A21	V <sub>SS</sub>	GND	---
A22	DQ40	I/O	DDR
A23	DQ41	I/O	DDR
A24	V <sub>SS</sub>	GND	---
A25	DQ42	I/O	DDR
A26	DQ43	I/O	DDR
A27	V <sub>SS</sub>	GND	---
A28	WE1#	I/O	DDR
A29	V <sub>SS</sub>	GND	---
A30	V <sub>MEM</sub>	PWR	---
A31	V <sub>SS</sub>	GND	---
B1	V <sub>MEM</sub>	PWR	---
B2	V <sub>SS</sub>	GND	---
B3	V <sub>SS</sub>	GND	---
B4	DQ17	I/O	DDR
B5	V <sub>MEM</sub>	PWR	---
B6	DQ18	I/O	DDR
B7	DQ23	I/O	DDR
B8	V <sub>MEM</sub>	PWR	---
B9	DQ24	I/O	DDR
B10	DQM3	I/O	DDR
B11	V <sub>MEM</sub>	PWR	---
B12	DQ27	I/O	DDR
B13	TLA1	I/O	DDR
B14	V <sub>SS</sub>	GND	---
B15	TLA0	I/O	DDR
B16	DQ36	I/O	DDR
B17	DQ33	I/O	DDR
B18	V <sub>SS</sub>	GND	---

Ball No.	Signal Name (Note 1)	Type (PD)	Buffer Type
B19	DQ34	I/O	DDR
B20	DQ38	I/O	DDR
B21	V <sub>MEM</sub>	PWR	---
B22	DQ35	I/O	DDR
B23	DQS5	I/O	DDR
B24	V <sub>MEM</sub>	PWR	---
B25	DQ46	I/O	DDR
B26	DQ47	I/O	DDR
B27	V <sub>MEM</sub>	PWR	---
B28	CS0#	I/O	DDR
B29	V <sub>SS</sub>	GND	---
B30	V <sub>SS</sub>	GND	---
B31	V <sub>MEM</sub>	PWR	---
C1	V <sub>SS</sub>	GND	---
C2	V <sub>SS</sub>	GND	---
C3	V <sub>MEM</sub>	PWR	---
C4	V <sub>SS</sub>	GND	---
C5	MA12	I/O	DDR
C6	DQS2	I/O	DDR
C7	V <sub>MEM</sub>	PWR	---
C8	DQ19	I/O	DDR
C9	DQ29	I/O	DDR
C10	DQ25	I/O	DDR
C11	DQ30	I/O	DDR
C12	V <sub>SS</sub>	GND	---
C13	MA3	I/O	DDR
C14	V <sub>MEM</sub>	PWR	---
C15	MA2	I/O	DDR
C16	MA0	I/O	DDR
C17	MA1	I/O	DDR
C18	V <sub>MEM</sub>	PWR	---
C19	DQS4	I/O	DDR
C20	BA1	I/O	DDR
C21	V <sub>SS</sub>	GND	---
C22	DQ44	I/O	DDR
C23	DQ45	I/O	DDR
C24	DQM5	I/O	DDR
C25	V <sub>MEM</sub>	PWR	---
C26	RAS0#	I/O	DDR
C27	WE0#	I/O	DDR
C28	V <sub>SS</sub>	GND	---
C29	V <sub>MEM</sub>	PWR	---
C30	V <sub>SS</sub>	GND	---
C31	V <sub>SS</sub>	GND	---
D1	DQ20	I/O	DDR
D2	DQ16	I/O	DDR
D3	V <sub>SS</sub>	GND	---
D4	V <sub>MEM</sub>	PWR	---
D5	MA11	I/O	DDR
D6	MA9	I/O	DDR

Ball No.	Signal Name (Note 1)	Type (PD)	Buffer Type
D7	V <sub>SS</sub>	GND	---
D8	MA7	I/O	DDR
D9	MA8	I/O	DDR
D10	V <sub>SS</sub>	GND	---
D11	MA5	I/O	DDR
D12	MA6	I/O	DDR
D13	MA4	I/O	DDR
D14	V <sub>SS</sub>	GND	---
D15	V <sub>CORE</sub>	PWR	---
D16	V <sub>SS</sub>	GND	---
D17	V <sub>CORE</sub>	PWR	---
D18	V <sub>SS</sub>	GND	---
D19	MA10	I/O	DDR
D20	SDCLK5P	O	DDRCLK
D21	SDCLK5N	O	DDRCLK
D22	V <sub>SS</sub>	GND	---
D23	SDCLK4P	O	DDRCLK
D24	SDCLK4N	O	DDRCLK
D25	V <sub>SS</sub>	GND	---
D26	BA0	I/O	DDR
D27	RAS1#	I/O	DDR
D28	V <sub>MEM</sub>	PWR	---
D29	V <sub>SS</sub>	GND	---
D30	CS3#	I/O	DDR
D31	DQ48	I/O	DDR
E1	V <sub>SS</sub>	GND	---
E2	V <sub>MEM</sub>	PWR	---
E3	DQ11	I/O	DDR
E4	CKE0	I/O	DDR
E28	CAS0#	I/O	DDR
E29	CAS1#	I/O	DDR
E30	V <sub>MEM</sub>	PWR	---
E31	V <sub>SS</sub>	GND	---
F1	DQ15	I/O	DDR
F2	DQ14	I/O	DDR
F3	DQ10	I/O	DDR
F4	CKE1	I/O	DDR
F28	CS1#	I/O	DDR
F29	CS2#	I/O	DDR
F30	MA13	I/O	DDR
F31	DQ49	I/O	DDR
G1	DQ13	I/O	DDR
G2	DQM1	I/O	DDR
G3	V <sub>MEM</sub>	PWR	---
G4	V <sub>SS</sub>	GND	---
G28	V <sub>SS</sub>	GND	---
G29	V <sub>MEM</sub>	PWR	---
G30	DQ52	I/O	DDR
G31	DQ53	I/O	DDR
H1	V <sub>MEM</sub>	PWR	---

Table 3-5. Ball Assignments - Sorted by Ball Number (Continued)

Ball No.	Signal Name (Note 1)	Type (PD)	Buffer Type
H2	V <sub>SS</sub>	GND	---
H3	DQS1	I/O	DDR
H4	SDCLK1N	O	DDRCLK
H28	SDCLK3N	O	DDRCLK
H29	DQM6	I/O	DDR
H30	V <sub>SS</sub>	GND	---
H31	V <sub>MEM</sub>	PWR	---
J1	DQ9	I/O	DDR
J2	DQ8	I/O	DDR
J3	DQ12	I/O	DDR
J4	SDCLK1P	O	DDRCLK
J28	SDCLK3P	O	DDRCLK
J29	DQS6	I/O	DDR
J30	DQ55	I/O	DDR
J31	DQ54	I/O	DDR
K1	DQ7	I/O	DDR
K2	DQ3	I/O	DDR
K3	V <sub>MEM</sub>	PWR	---
K4	V <sub>SS</sub>	GND	---
K28	V <sub>SS</sub>	GND	---
K29	V <sub>MEM</sub>	PWR	---
K30	DQ50	I/O	DDR
K31	DQ51	I/O	DDR
L1	V <sub>MEM</sub>	PWR	---
L2	V <sub>SS</sub>	GND	---
L3	DQ6	I/O	DDR
L4	SDCLK0N	O	DDRCLK
L28	SDCLK2N	O	DDRCLK
L29	DQ60	I/O	DDR
L30	V <sub>SS</sub>	GND	---
L31	V <sub>MEM</sub>	PWR	---
M1	DQM0	I/O	DDR
M2	DQS0	I/O	DDR
M3	DQ2	I/O	DDR
M4	SDCLK0P	O	DDRCLK
M28	SDCLK2P	O	DDRCLK
M29	DQ61	I/O	DDR
M30	DQ57	I/O	DDR
M31	DQ56	I/O	DDR
N1	DQ5	I/O	DDR
N2	DQ1	I/O	DDR
N3	V <sub>SS</sub>	GND	---
N4	V <sub>MEM</sub>	PWR	---
N13	V <sub>CORE</sub>	PWR	---
N14	V <sub>CORE</sub>	PWR	---
N15	V <sub>SS</sub>	GND	---
N16	V <sub>SS</sub>	GND	---
N17	V <sub>SS</sub>	GND	---
N18	V <sub>CORE</sub>	PWR	---
N19	V <sub>CORE</sub>	PWR	---

Ball No.	Signal Name (Note 1)	Type (PD)	Buffer Type
N28	V <sub>SS</sub>	GND	---
N29	V <sub>MEM</sub>	PWR	---
N30	DQM7	I/O	DDR
N31	DQS7	I/O	DDR
P1	MVREF	I	---
P2	DQ0	I/O	DDR
P3	DQ4	I/O	DDR
P4	V <sub>SS</sub>	GND	---
P13	V <sub>CORE</sub>	PWR	---
P14	V <sub>CORE</sub>	PWR	---
P15	V <sub>SS</sub>	GND	---
P16	V <sub>SS</sub>	GND	---
P17	V <sub>SS</sub>	GND	---
P18	V <sub>CORE</sub>	PWR	---
P19	V <sub>CORE</sub>	PWR	---
P28	V <sub>SS</sub>	GND	---
P29	V <sub>MEM</sub>	PWR	---
P30	DQ62	I/O	DDR
P31	V <sub>SS</sub>	GND	---
R1	V <sub>SS</sub>	GND	---
R2	V <sub>SS</sub>	GND	---
R3	V <sub>SS</sub>	GND	---
R4	V <sub>SS</sub>	GND	---
R13	V <sub>SS</sub>	GND	---
R14	V <sub>SS</sub>	GND	---
R15	V <sub>SS</sub>	GND	---
R16	V <sub>SS</sub>	GND	---
R17	V <sub>SS</sub>	GND	---
R18	V <sub>SS</sub>	GND	---
R19	V <sub>SS</sub>	GND	---
R28	V <sub>CORE</sub>	PWR	---
R29	DQ63	I/O	DDR
R30	DQ58	I/O	DDR
R31	DQ59	I/O	DDR
T1	V <sub>CORE</sub>	PWR	---
T2	V <sub>CORE</sub>	PWR	---
T3	V <sub>CORE</sub>	PWR	---
T4	V <sub>CORE</sub>	PWR	---
T13	V <sub>SS</sub>	GND	---
T14	V <sub>SS</sub>	GND	---
T15	V <sub>SS</sub>	GND	---
T16	V <sub>SS</sub>	GND	---
T17	V <sub>SS</sub>	GND	---
T18	V <sub>SS</sub>	GND	---
T19	V <sub>SS</sub>	GND	---
T28	V <sub>SS</sub>	GND	---
T29	V <sub>SS</sub>	GND	---
T30	V <sub>SS</sub>	GND	---

Ball No.	Signal Name (Note 1)	Type (PD)	Buffer Type
T31	V <sub>SS</sub>	GND	---
U1	DAV <sub>DD</sub>	APWR	---
U2	BLUE	A	---
U3	DAV <sub>SS</sub>	AGND	---
U4	V <sub>CORE</sub>	PWR	---
U13	V <sub>SS</sub>	GND	---
U14	V <sub>SS</sub>	GND	---
U15	V <sub>SS</sub>	GND	---
U16	V <sub>SS</sub>	GND	---
U17	V <sub>SS</sub>	GND	---
U18	V <sub>SS</sub>	GND	---
U19	V <sub>SS</sub>	GND	---
U28	V <sub>CORE</sub>	PWR	---
U29	V <sub>CORE</sub>	PWR	---
U30	V <sub>CORE</sub>	PWR	---
U31	V <sub>CORE</sub>	PWR	---
V1	DAV <sub>DD</sub>	APWR	---
V2	GREEN	A	---
V3	DAV <sub>SS</sub>	AGND	---
V4	DAV <sub>DD</sub>	APWR	---
V13	V <sub>CORE</sub>	PWR	---
V14	V <sub>CORE</sub>	PWR	---
V15	V <sub>SS</sub>	GND	---
V16	V <sub>SS</sub>	GND	---
V17	V <sub>SS</sub>	GND	---
V18	V <sub>CORE</sub>	PWR	---
V19	V <sub>CORE</sub>	PWR	---
V28	V <sub>CORE</sub>	PWR	---
V29	MLPF	A	---
V30	MAV <sub>SS</sub>	AGND	---
V31	MAV <sub>DD</sub>	APWR	---
W1	DVREF	A	---
W2	DAV <sub>SS</sub>	AGND	---
W3	RED	A	---
W4	DAV <sub>DD</sub>	APWR	---
W13	V <sub>CORE</sub>	PWR	---
W14	V <sub>CORE</sub>	PWR	---
W15	V <sub>SS</sub>	GND	---
W16	V <sub>SS</sub>	GND	---
W17	V <sub>SS</sub>	GND	---
W18	V <sub>CORE</sub>	PWR	---
W19	V <sub>CORE</sub>	PWR	DDR
W28	V <sub>SS</sub>	GND	---
W29	CLPF	A	---
W30	CAV <sub>SS</sub>	AGND	---
W31	CAV <sub>DD</sub>	APWR	---
Y1	DRSET	A	---

**Table 3-5. Ball Assignments - Sorted by Ball Number (Continued)**

Ball No.	Signal Name (Note 1)	Type (PD)	Buffer Type
Y2	DAV <sub>SS</sub>	AGND	---
Y3	V <sub>IO</sub>	PWR	---
Y4	V <sub>SS</sub>	GND	---
Y28	V <sub>CORE</sub>	PWR	---
Y29	V <sub>SS</sub>	GND	---
Y30	RESET#	I	PCI
Y31	SYSREF	I	PCI
AA1	VAV <sub>DD</sub>	APWR	---
AA2	VAV <sub>SS</sub>	AGND	---
AA3	VLPF	A	---
AA4	TMS	I	24/Q7
AA28	GNT0#	I/O	PCI
AA29	REQ0#	I	PCI
AA30	V <sub>SS</sub>	GND	---
AA31	V <sub>IO</sub>	PWR	---
AB1	DOTREF	I	PCI
AB2	TDBGI	I	24/Q7
AB3	TDI	I	24/Q7
AB4	TDBGO	O (PD)	24/Q3
AB28	REQ2#	I/O	PCI
AB29	IRQ13	I/O (PD)	24/Q5
AB30	GNT1#	I/O	PCI
AB31	REQ1#	I/O	PCI
AC1	TDO	O	24/Q5
AC2	TCLK	I	24/Q7
AC3	V <sub>IO</sub>	PWR	---
AC4	V <sub>SS</sub>	GND	---
AC28	V <sub>SS</sub>	GND	---
AC29	V <sub>IO</sub>	PWR	---
AC30	GNT2#	I/O	PCI
AC31	SUSPA#	I/O	24/Q5
AD1	V <sub>IO</sub>	PWR	---
AD2	V <sub>SS</sub>	GND	---
AD3	VSYNC	O (PD)	5V
	VOP_VSYNC	O	
AD4	LDEMOD	I/O (PD)	24/Q5
	VIP_VSYNC	I	
AD28	INTA#	I/O (PD)	24/Q5
AD29	AD31	I/O	PCI
AD30	V <sub>SS</sub>	GND	---
AD31	V <sub>IO</sub>	PWR	---
AE1	DOTCLK	O (PD)	24/Q3
	VOPCLK	O	
AE2	VDDEN	I/O (PD)	24/Q5
	VIP_HSYNC	I	
AE3	HSYNC	O (PD)	5V
	VOP_HSYNC	O	
AE4	DISPEN	O (PD)	24/Q5
	VOP_BLANK	O	
AE28	AD27	I/O	PCI

Ball No.	Signal Name (Note 1)	Type (PD)	Buffer Type
AE29	CIS	I/O	24/Q7
AE30	AD29	I/O	PCI
AE31	AD30	I/O	PCI
AF1	DRGB17	O (PD)	24/Q5
AF2	DRGB16	O (PD)	24/Q5
AF3	V <sub>IO</sub>	PWR	---
AF4	V <sub>SS</sub>	GND	---
AF28	V <sub>SS</sub>	GND	---
AF29	V <sub>IO</sub>	PWR	---
AF30	AD26	I/O	PCI
AF31	AD28	I/O	PCI
AG1	V <sub>IO</sub>	PWR	---
AG2	V <sub>SS</sub>	GND	---
AG3	DRGB18	O (PD)	24/Q5
AG4	DRGB19	O (PD)	24/Q5
AG28	AD25	I/O	PCI
AG29	AD24	I/O	PCI
AG30	V <sub>SS</sub>	GND	---
AG31	V <sub>IO</sub>	PWR	---
AH1	DRGB20	O (PD)	24/Q5
AH2	DRGB21	O (PD)	24/Q5
AH3	DRGB22	O (PD)	24/Q5
AH4	V <sub>SS</sub>	GND	---
AH5	DRGB11	O (PD)	24/Q5
	VOP12	O	
AH6	V <sub>SS</sub>	GND	---
AH7	DRGB0	O (PD)	24/Q5
	VOP7	O	
AH8	DRGB6	O (PD)	24/Q5
	VOP1	O	
AH9	V <sub>SS</sub>	GND	---
AH10	DRGB29	I/O (PD)	24/Q5
	VID13	I	
AH11	DRGB24	I/O (PD)	24/Q5
	MSGSTART	I	
	VID8	I	
AH12	V <sub>SS</sub>	GND	---
AH13	VID3	I/O (PD)	24/Q7
AH14	V <sub>SS</sub>	GND	---
AH15	V <sub>CORE</sub>	PWR	---
AH16	V <sub>SS</sub>	GND	---
AH17	V <sub>CORE</sub>	PWR	---
AH18	V <sub>SS</sub>	GND	---
AH19	AD1	I/O	PCI
AH20	V <sub>SS</sub>	GND	---
AH21	AD5	I/O	PCI
AH22	AD11	I/O	PCI
AH23	V <sub>SS</sub>	GND	---
AH24	AD14	I/O	PCI
AH25	IRDY#	I/O	PCI

Ball No.	Signal Name (Note 1)	Type (PD)	Buffer Type
AH26	V <sub>SS</sub>	GND	---
AH27	CBE2#	I/O	PCI
AH28	V <sub>SS</sub>	GND	---
AH29	AD23	I/O	PCI
AH30	AD22	I/O	PCI
AH31	CBE3#	I/O	PCI
AJ1	DRGB23	O (PD)	24/Q5
AJ2	DRGB8	O (PD)	24/Q5
	VOP15	O	
AJ3	V <sub>IO</sub>	PWR	---
AJ4	DRGB12	O (PD)	24/Q5
	VOP11	O	
AJ5	DRGB15	O (PD)	24/Q5
	VOP8	O	
AJ6	V <sub>IO</sub>	PWR	---
AJ7	DRGB3	O (PD)	24/Q5
	VOP4	O	
AJ8	DRGB7	O (PD)	24/Q5
	VOP0	O	
AJ9	V <sub>IO</sub>	PWR	---
AJ10	DRGB28	I/O (PD)	24/Q5
	VID12	O	
AJ11	DRGB25	I/O (PD)	24/Q5
	MSGSTOP	I	
	VID9	I	
AJ12	V <sub>IO</sub>	PWR	---
AJ13	VID4	I/O (PD)	24/Q7
AJ14	V <sub>IO</sub>	PWR	---
AJ15	VID0	I/O (PD)	24/Q7
AJ16	V <sub>SS</sub>	GND	---
AJ17	PW1	I/O	24/Q7
AJ18	V <sub>IO</sub>	PWR	---
AJ19	AD0	I/O	PCI
AJ20	V <sub>IO</sub>	PWR	---
AJ21	AD6	I/O	PCI
AJ22	CBE0#	I/O	PCI
AJ23	V <sub>IO</sub>	PWR	---
AJ24	AD15	I/O	PCI
AJ25	STOP#	I/O	PCI
AJ26	V <sub>IO</sub>	PWR	---
AJ27	PAR	I/O	PCI
AJ28	AD16	I/O	PCI
AJ29	V <sub>IO</sub>	PWR	---
AJ30	AD19	I/O	PCI
AJ31	AD21	I/O	PCI
AK1	V <sub>IO</sub>	PWR	---
AK2	V <sub>SS</sub>	GND	---
AK3	DRGB9	O (PD)	24/Q5
	VOP14	O	

Table 3-5. Ball Assignments - Sorted by Ball Number (Continued)

Ball No.	Signal Name (Note 1)	Type (PD)	Buffer Type
AK4	DRGB14	O (PD)	24/Q5
	VOP9	O	
AK5	V <sub>SS</sub>	GND	---
AK6	DRGB1	O (PD)	24/Q5
	VOP6	O	
AK7	DRGB4	O (PD)	24/Q5
	VOP3	O	
AK8	V <sub>SS</sub>	GND	---
AK9	DRGB31	I/O (PD)	24/Q5
	VID15	I	
AK10	DRGB26	I/O (PD)	24/Q5
	VID10	I	
AK11	V <sub>SS</sub>	GND	---
AK12	VID7	I/O (PD)	24/Q7
AK13	VID5	I/O (PD)	24/Q7
AK14	V <sub>SS</sub>	GND	---
AK15	VID1	I/O (PD)	24/Q7
AK16	V <sub>SS</sub>	GND	---
AK17	TDN	A	A
AK18	V <sub>SS</sub>	GND	---
AK19	AD4	I/O	PCI
AK20	AD3	I/O	PCI
AK21	V <sub>SS</sub>	GND	---
AK22	AD8	I/O	PCI
AK23	AD10	I/O	PCI

Ball No.	Signal Name (Note 1)	Type (PD)	Buffer Type
AK24	V <sub>SS</sub>	GND	---
AK25	DEVSEL#	I/O	PCI
AK26	TRDY#	I/O	PCI
AK27	V <sub>SS</sub>	GND	---
AK28	AD17	I/O	PCI
AK29	AD20	I/O	PCI
AK30	V <sub>SS</sub>	GND	---
AK31	V <sub>IO</sub>	PWR	---
AL1	V <sub>SS</sub>	GND	---
AL2	V <sub>IO</sub>	PWR	---
AL3	DRGB10	O (PD)	24/Q5
	VOP13	O	
AL4	DRGB13	O (PD)	24/Q5
	VOP10	O	
AL5	V <sub>IO</sub>	PWR	---
AL6	DRGB2	O (PD)	24/Q5
	VOP5	O	
AL7	DRGB5	O (PD)	24/Q5
	VOP2	O	
AL8	V <sub>IO</sub>	PWR	---
AL9	DRGB30	I/O (PD)	24/Q5
	VID14	I	
AL10	DRGB27	I/O (PD)	24/Q5
	VID11	I	

Ball No.	Signal Name (Note 1)	Type (PD)	Buffer Type
AL11	V <sub>IO</sub>	PWR	---
AL12	VIPCLK	I/O (PD)	5V
AL13	VID6	I/O (PD)	24/Q7
AL14	VIPSYNCR	I/O (PD)	5V
AL15	VID2	I/O (PD)	24/Q7
AL16	V <sub>SS</sub>	GND	---
AL17	TDP	A	---
AL18	PW0	I/O	24/Q7
AL19	AD7	I/O	PCI
AL20	AD2	I/O	PCI
AL21	V <sub>IO</sub>	PWR	---
AL22	AD9	I/O	PCI
AL23	AD12	I/O	PCI
AL24	V <sub>IO</sub>	PWR	---
AL25	AD13	I/O	PCI
AL26	CBE1#	I/O	PCI
AL27	V <sub>IO</sub>	PWR	---
AL28	FRAME#	I/O	PCI
AL29	AD18	I/O	PCI
AL30	V <sub>IO</sub>	PWR	---
AL31	V <sub>SS</sub>	GND	---

Note 1. The primary signal name is listed first.

Table 3-6. Ball Assignments - Sorted Alphabetically by Signal Name

Signal Name	Ball No.	Signal Name	Ball No.	Signal Name	Ball No.
AD0	AJ19	CS1#	F28	DQ39	A20
AD1	AH19	CS2#	F29	DQ40	A22
AD2	AL20	CS3#	D30	DQ41	A23
AD3	AK20	DAV <sub>DD</sub>	U1, V1, V4, W4	DQ42	A25
AD4	AK19	DAV <sub>SS</sub>	U3, V3, Y2, W2	DQ43	A26
AD5	AH21	DEVSEL#	AK25	DQ44	C22
AD6	AJ21	DISPEN	AE4	DQ45	C23
AD7	AL19	DOTCLK	AE1	DQ46	B25
AD8	AK22	DOTREF	AB1	DQ47	B26
AD9	AL22	DQ0	P2	DQ48	D31
AD10	AK23	DQ1	N2	DQ49	F31
AD11	AH22	DQ2	M3	DQ50	K30
AD12	AL23	DQ3	K2	DQ51	K31
AD13	AL25	DQ4	P3	DQ52	G30
AD14	AH24	DQ5	N1	DQ53	G31
AD15	AJ24	DQ6	L3	DQ54	J31
AD16	AJ28	DQ7	K1	DQ55	J30
AD17	AK28	DQ8	J2	DQ56	M31
AD18	AL29	DQ9	J1	DQ57	M30
AD19	AJ30	DQ10	F3	DQ58	R30
AD20	AK29	DQ11	E3	DQ59	R31
AD21	AJ31	DQ12	J3	DQ60	L29
AD22	AH30	DQ13	G1	DQ61	M29
AD23	AH29	DQ14	F2	DQ62	P30
AD24	AG29	DQ15	F1	DQ63	R29
AD25	AG28	DQ16	D2	DQM0	M1
AD26	AF30	DQ17	B4	DQM1	G2
AD27	AE28	DQ18	B6	DQM2	A6
AD28	AF31	DQ19	C8	DQM3	B10
AD29	AE30	DQ20	D1	DQM4	A19
AD30	AE31	DQ21	A4	DQM5	C24
AD31	AD29	DQ22	A7	DQM6	H29
BA0	D26	DQ23	B7	DQM7	N30
BA1	C20	DQ24	B9	DQS0	M2
BLUE	U2	DQ25	C10	DQS1	H3
CAS0#	E28	DQ26	A12	DQS2	C6
CAS1#	E29	DQ27	B12	DQS3	A10
CAV <sub>DD</sub>	W31	DQ28	A9	DQS4	C19
CAV <sub>SS</sub>	W30	DQ29	C9	DQS5	B23
CBE0#	AJ22	DQ30	C11	DQS6	J29
CBE1#	AL26	DQ31	A13	DQS7	N31
CBE2#	AH27	DQ32	A15	DRGB0	AH7
CBE3#	AH31	DQ33	B17	DRGB1	AK6
CIS	AE29	DQ34	B19	DRGB2	AL6
CKE0	E4	DQ35	B22	DRGB3	AJ7
CKE1	F4	DQ36	B16	DRGB4	AK7
CLPF	W29	DQ37	A17	DRGB5	AL7
CS0#	B28	DQ38	B20	DRGB6	AH8

Table 3-6. Ball Assignments - Sorted Alphabetically by Signal Name (Continued)

Signal Name	Ball No.	Signal Name	Ball No.	Signal Name	Ball No.
DRGB7	AJ8	MA11	D5	V <sub>CORE</sub> (Total of 32)	D15, D17, N13, N14, N18, N19, P13, P14, P18, P19, R28, T1, T2, T3, T4, U4, V13, V14, V18, V19, U28, U29, U30, U31, V28, W13, W14, W18, W19, Y28, AH15, AH17
DRGB8	AJ2	MA12	C5	VDDEN	AE2
DRGB9	AK3	MA13	F30	V <sub>IO</sub> (Total of 30)	Y3, AA31, AJ3, AJ6, AJ9, AJ12, AJ14, AJ18, AJ20, AJ23, AJ26, AJ29, AC3, AK1, AK31, AL2, AL5, AL8, AL11, AL21, AL24, AL27, AL30, AC29, AD1, AD31, AF3, AF29, AG1, AG31
DRGB10	AL3	MAV <sub>DD</sub>	V31	VID0	AJ15
DRGB11	AH5	MAV <sub>SS</sub>	V30	VID1	AK15
DRGB12	AJ4	MLPF	V29	VID2	AL15
DRGB13	AL4	MSGSTART	AH11	VID3	AH13
DRGB14	AK4	MSGSTOP	AJ11	VID4	AJ13
DRGB15	AJ5	MVREF	P1	VID5	AK13
DRGB16	AF2	PAR	AJ27	VID6	AL13
DRGB17	AF1	PW0	AL18	VID7	AK12
DRGB18	AG3	PW1	AJ17	VID8	AH11
DRGB19	AG4	RAS0#	C26	VID9	AJ11
DRGB20	AH1	RAS1#	D27	VID10	AK10
DRGB21	AH2	RED	W3	VID11	AL10
DRGB22	AH3	REQ0#	AA29	VID12	AJ10
DRGB23	AJ1	REQ1#	AB31	VID13	AH10
DRGB24	AH11	REQ2#	AB28	VID14	AL9
DRGB25	AJ11	RESET#	Y30	VID15	AK9
DRGB26	AK10	SDCLK0N	L4	VIPCLK	AL12
DRGB27	AL10	SDCLK0P	M4	VIP_HSYNC	AE2
DRGB28	AJ10	SDCLK1N	H4	VIPSYNC	AL14
DRGB29	AH10	SDCLK1P	J4	VIP_VSYNC	AD4
DRGB30	AL9	SDCLK2N	L28	VLPF	AA3
DRGB31	AK9	SDCLK2P	M28	VOP0	AJ8
DRSET	Y1	SDCLK3N	H28	VOP1	AH8
DVREF	W1	SDCLK3P	J28	VOP2	AL7
FRAME#	AL28	SDCLK4N	D24	VOP3	AK7
GNT0#	AA28	SDCLK4P	D23	VOP4	AJ7
GNT1#	AB30	SDCLK5N	D21	VOP5	AL6
GNT2#	AC30	SDCLK5P	D20	VOP6	AK6
GREEN	V2	STOP#	AJ25	VOP7	AH7
HSYNC	AE3	SUSPA#	AC31	VOP8	AJ5
INTA#	AD28	SYSREF	Y31	VOP9	AK4
IRDY#	AH25	TCLK	AC2	VOP10	AL4
IRQ13	AB29	TDBGI	AB2	VOP11	AJ4
LDEMOD	AD4	TDBGO	AB4	VOP12	AH5
MA0	C16	TDI	AB3		
MA1	C17	TDN	AK17		
MA2	C15	TDO	AC1		
MA3	C13	TDP	AL17		
MA4	D13	TLA0	B15		
MA5	D11	TLA1	B13		
MA6	D12	TMS	AA4		
MA7	D8	TRDY#	AK26		
MA8	D9	VAV <sub>DD</sub>	AA1		
MA9	D6	VAV <sub>SS</sub>	AA2		
MA10	D19				

**Table 3-6. Ball Assignments - Sorted Alphabetically by Signal Name (Continued)**

Signal Name	Ball No.
VOP13	AL3
VOP14	AK3
VOP15	AJ2
VOP_BLANK	AE4
VOPCLK	AE1
VOP_HSYNC	AE3
VOP_VSYNC	AD3
V <sub>MEM</sub> (Total of 33)	A2, A14, B1, B5, B8, B11, B21, B24, B27, B31, C3, C7, C14, C18, C25, C29, D4, D28, A18, E2, E30, G3, G29, H1, H31, K3, K29, L1, L31, A30, N4, N29, P29

Signal Name	Ball No.
V <sub>SS</sub> (Total of 128)	A1, A3, A29, A31, AA30, AC4, AC28, AD2, AD30, AF4, AF28, AG2, AG30, AH4, AH6, AH9, AH12, AH14, AH16, AH18, AH20, B2, AH23, AH26, AH28, AJ16, AK2, AK5, AK8, AK11, AK14, AK16, B3, AK18, AK21, AK24, AK27, AK30, AL1, AL16, AL31, B14, B18, B29, B30, C1, C2, C4, A5, C12, C21, C28, C30, C31, D3, D7, D10, D14, D16, A8, D18, D22, D25, D29, E1, E31, G4, G28, H2, H30, A11, K4, K28, L2, L30, N3, N15, N16, N17, N28, P4, A16, P15, P16, P17, P28, P31, R1, R2, R3, R4, R13, A21, R14, R15, R16, R17, R18, R19, T13, T14, T15, T16, A24, T17, T18, T19, T28, T29, T30, T31, U13, U14, U15, A27, U16, U17, U18, U19, V15, V16, V17, W15, W16, W17, W28, Y4, Y29

Signal Name	Ball No.
VSYNC	AD3
WE0#	C27
WE1#	A28



## 3.4 Signal Descriptions

### 3.4.1 System Interface Signals

Signal Name	Ball No.	Type	f	V	Description
SYSREF	Y31	I	33, 66 MHz	3.3	<b>System Reference.</b> PCI input clock; typically 33 or 66 MHz.
DOTREF	AB1	I	48 MHz	3.3	<b>Dot Clock Reference.</b> Input clock for DOTCLK PLL.
INTA#	AD28	I/O (PD)	0-66 Mb/s	3.3	<b>Interrupt.</b> Interrupt from the AMD Geode LX processor to the CS5536 companion device (open drain).
IRQ13	AB29 (Strap)	I/O (PD)	0-66 Mb/s	3.3	<b>Interrupt Request Level 13.</b> When a floating point error occurs, the AMD Geode LX processor asserts IRQ13. The floating point interrupt handler then performs an OUT instruction to I/O address F0h or F1h. The AMD Geode LX processor accepts either of these cycles and clears IRQ13.  IRQ13 is an output during normal operation. It is an input at reset and functions as a boot strap for tester features on a board. It must be pulled low for normal operation.
CIS	AE29	I/O	0-66 Mb/s	3.3	<b>CPU Interface Serial.</b> The GLCP I/O companion interface uses the CIS signal to create a serial bus. It contains INTR#, SUSP#, NMI#, INPUT_DIS#, OUTPUT_DIS#, and SMI#. For details see "GIO_PCI Serial Protocol" on page 538.
SUSPA#	AC31 (Strap)	I/O	0-66 Mb/s	3.3	<b>Suspend Acknowledge.</b> Suspend Acknowledge indicates that the AMD Geode LX processor has entered low-power Suspend mode as a result of SUSP# assertion (as part of the packet asserted on the CIS signal) or execution of a HLT instruction. (The AMD Geode LX processor enters Suspend mode following execution of a HLT instruction if the SUSPONHLT bit, MSR 00001210h[0], is set.)  The SYSREF input may be stopped after SUSPA# has been asserted to further reduce power consumption if the system is configured for 3 Volt Suspend mode.  SUSPA# is an output during normal operation. It is an input at reset and functions as a boot strap for frequency selection on a board. It must be pulled high or low to invoke the strap.
PW0, PW1	AL18, AJ17 (Strap)	I/O	0-300 Mb/s	3.3	<b>PowerWise Controls.</b> Used for debug.  PWx is an output during normal operation. It is an input at reset and functions as a boot strap for frequency selection on a board. It must be pulled high or low to invoke the strap.

### 3.4.1 System Interface Signals (Continued)

Signal Name	Ball No.	Type	f	V	Description
TDP	AL17	A	Analog	N/A	<p><b>Thermal Diode Positive (TDP).</b> TDP is the positive terminal of the thermal diode on the die. The diode is used to do thermal characterization of the device in a system. This signal works in conjunction with TDN.</p> <p>For accurate die temperature measurements, a dual current source remote sensor, such as the National Semiconductor LM82, should be used. Single current source sensors may not yield the desired level of accuracy.</p> <p>If reading the CPU temperature is required while the system is off, then a small bias (&lt;0.25V) on <math>V_{IO}</math> is required for the thermal diode to operate properly.</p>
TDN	AK17	A	Analog	N/A	<p><b>Thermal Diode Negative (TDN).</b> TDN is the negative terminal of the thermal diode on the die. The diode is used to do thermal characterization of the device in a system. This signal works in conjunction with TDP.</p> <p>For accurate die temperature measurements, a dual current source remote sensor, such as the National Semiconductor LM82, should be used. Single current source sensors may not yield the desired level of accuracy.</p> <p>If reading the CPU temperature is required while the system is off, then a small bias (&lt;0.25V) on <math>V_{IO}</math> is required for the thermal diode to operate properly.</p>

### 3.4.2 PLL Interface Signals

Signal Name	Ball No.	Type	f	V	Description
CAV <sub>DD</sub>	W31	APWR	Analog	3.3	<b>Core PLL Analog Power.</b> Connect to 3.3V.
CAV <sub>SS</sub>	W30	APWR	Analog	0	<b>Core PLL Analog Ground.</b> Connect to ground.
MAV <sub>DD</sub>	V31	APWR	Analog	3.3	<b>GLIU PLL Analog Power.</b> Connect to 3.3V.
MAV <sub>SS</sub>	V30	APWR	Analog	0	<b>GLIU PLL Analog Ground.</b> Connect to ground.
VAV <sub>DD</sub>	AA1	APWR	Analog	3.3	<b>Video PLL Analog Power.</b> Connect to 3.3V.
VAV <sub>SS</sub>	AA2	APWR	Analog	0	<b>Video PLL Analog Ground.</b> Connect to ground.
CLPF	W29	A	Analog	N/A	<b>Core PLL Low Pass Filter.</b> 220 pF to CAV <sub>SS</sub> .
MLPF	V29	A	Analog	N/A	<b>GLIU PLL Low Pass Filter.</b> 220 pF to MAV <sub>SS</sub> .
VLPF	AA3	A	Analog	N/A	<b>Video PLL Low Pass Filter.</b> 220 pF to VAV <sub>SS</sub> .

### 3.4.3 Memory Interface Signals (DDR)

Signal Name	Ball No.	Type	f	V	Description
SDCLK[5:0]P, SDCLK[5:0]N	D20, D21, D23, D24, J28, H28, M28, L28, J4, H4, M4, L4	O	up to 200 MHz	2.5	<b>SDRAM Clock Differential Pairs.</b> The SDRAM devices sample all the control, address, and data based on these clocks. All clocks are differential clock outputs.
MVREF	P1	I	Analog	V <sub>MEM</sub>	<b>Memory Voltage Reference.</b> This input operates at half the V <sub>MEM</sub> voltage.
CKE[1:0]	F4, E4	I/O	up to 200 Mb/s	2.5	<b>Clock Enable.</b> For normal operation, CKE is held high. CKE goes low during Suspend. CKE0 is used with CS0# and CS1#. CKE1 is used with CS2# and CS3#.
CS[3:0]#	D30, F29, F28, B28	I/O	up to 200 Mb/s	2.5	<b>Chip Selects.</b> The chip selects are used to select the module bank within the system memory. Each chip select corresponds to a specific module bank.  If CS# is high, the bank(s) do not respond to RAS#, CAS#, or WE# until the bank is selected again.
RAS[1:0]#	D27, C26	I/O	up to 200 Mb/s	2.5	<b>Row Address Strobe.</b> RAS#, CAS#, WE#, and CKE are encoded to support the different SDRAM commands. RAS0# is used with CS0# and CS1#. RAS1# is used with CS2# and CS3#.
CAS[1:0]#	E29, E28	I/O	up to 200 Mb/s	2.5	<b>Column Address Strobe.</b> RAS#, CAS#, WE#, and CKE are encoded to support the different SDRAM commands. CAS0# is used with CS0# and CS1#. CAS1# is used with CS2# and CS3#.
WE[1:0]#	A28, C27	I/O	up to 200 Mb/s	2.5	<b>Write Enable.</b> RAS#, CAS#, WE#, and CKE are encoded to support the different SDRAM commands. WE0# is used with CS0# and CS1#. WE1# is used with CS2# and CS3#.
BA[1:0]	C20, D26	I/O	up to 200 Mb/s	2.5	<b>Bank Address Bits.</b> These bits are used to select the component bank within the SDRAM.
MA[13:0]	See Table 3-6 on page 30	I/O	up to 200 Mb/s	2.5	<b>Memory Address Bus.</b> The multiplexed row/column address lines driven to the system memory.  Supports 256-Mbit SDRAM.
TLA[1:0]	B13, B15	I/O	up to 200 Mb/s	2.5	<b>Memory Debug Pins.</b> These pins provide useful memory interface debug timing signals. (Should be wired to DIMM slot.)  TLA[0] is wired to DQS[8] on the DIMM TLA[1] is wired to CB[0] on the DIMM
DQS[7:0]	N31, J29, B23, C19, A10, C6, H3, M2	I/O	up to 200 MHz	2.5	<b>DDR Data Strobe.</b>

### 3.4.3 Memory Interface Signals (DDR) (Continued)

Signal Name	Ball No.	Type	f	V	Description
DQM[7:0]	N30, H29, C24, A19, B10, A6, G2, M1	I/O	166-400 Mb/s	2.5	<p><b>Data Mask Control Bits.</b> During memory read cycles, these outputs control whether the SDRAM output buffers are driven on the Memory Data Bus or not. All DQM signals are asserted during read cycles.</p> <p>During memory write cycles, these outputs control whether or not memory data is written into the SDRAM.</p> <p>DQM[0] is associated with MD[7:0]. DQM[7] is associated with MD[63:56].</p>
DQ[63:0]	See Table 3-6 on page 30	I/O	166-400 Mb/s	2.5	<b>Memory Data Bus.</b>

### 3.4.4 Internal Test and Measurement Interface Signals

Signal Name	Ball No.	Type	f	V	Description
TCLK	AC2	I	0-66 MHz	3.3	<b>Test Clock.</b> JTAG test clock.
TMS	AA4	I	0-66 Mb/s	3.3	<b>Test Mode Select.</b> JTAG test mode select.
TDI	AB3	I	0-66 Mb/s	3.3	<b>Test Data Input.</b> JTAG serial test data input.
TDO	AC1	O	0-66 Mb/s	3.3	<b>Test Data Output.</b> JTAG serial test data output.
TDBGI	AB2	I	0-400 Mb/s	3.3	<b>Test Debug Input.</b> The Debug Management Interrupt (DMI) is input via TDBGI. The selects for TDBGI are MSR programmable via the GLCP module. When using TDBGI for DMI, it cannot be used for other debug purposes. DMI can be setup via the GLCP module to be edge sensitive or level sensitive
TDBGO	AB4	O (PD)	0-400 Mb/s	3.3	<b>Test Debug Output.</b> The AMD Geode LX processor can output internal clocks on TDBGO. The selects for TDBGO are MSR programmable via the GLCP module. The internal clock can be selected from any clock domain and may be divided down by 2 or 3 before output. This enables tester and board level visibility of the internal clock quality.

## 3.4.5 PCI Interface Signals

Signal Name	Ball No.	Type	f	V	Description
AD[31:0]	See Table 3-6 on page 30	I/O	33-66 Mb/s	3.3	<b>Multiplexed Address and Data.</b> Addresses and data are multiplexed together on the same pins. A bus transaction consists of an address phase in the cycle in which FRAME# is asserted followed by one or more data phases. During the address phase, AD[31:0] contain a physical 32-bit address. During data phases, AD[7:0] contain the least significant byte (LSB) and AD[31:24] contain the most significant byte (MSB). Write data is stable and valid when IRDY# is asserted and read data is stable and valid when TRDY# is asserted. Data is transferred during the SYSREF when both IRDY# and TRDY# are asserted.
CBE[3:0]#	AH31, AH27, AL26, AJ22	I/O	33-66 Mb/s	3.3	<b>Multiplexed Command and Byte Enables.</b> C/BE# are the bus commands and byte enables. During the address phase of a transaction when FRAME# is active, C/BE# define the bus command. During the data phase C/BE# are used as byte enables. The byte enables are valid for the entire data phase and determine which byte lanes carry meaningful data. C/BE0# applies to byte 0 (LSB) and C/BE3# applies to byte 3 (MSB). The command encoding and types are listed below:  0000: Interrupt Acknowledge 0001: Special Cycle 0010: I/O Read 0011: I/O Write 0100: Reserved 0101: Reserved 0110: Memory Read 0111: Memory Write 1000: Reserved 1001: Reserved 1010: Configuration Read 1011: Configuration Write 1100: Memory Read Multiple 1101: Dual Address Cycle (RSVD) 1110: Memory Read Line 1111: Memory Write and Invalidate
PAR	AJ27	I/O	33-66 Mb/s	3.3	<b>Parity.</b> PAR is used with AD[31:0] and C/BE# to generate even parity. Parity generation is required by all PCI agents: the master drives PAR for address and write-data phases and the target drives PAR for read-data phases.  For address phases, PAR is stable and valid one SYSREF after the address phase.  For data phases, PAR is stable and valid one SYSREF after either IRDY# is asserted on a write transaction or after TRDY# is asserted on a read transaction. Once PAR is valid, it remains valid until one SYSREF after the completion of the data phase.

## 3.4.5 PCI Interface Signals (Continued)

Signal Name	Ball No.	Type	f	V	Description
RESET#	Y30	I	0-1 Mb/s	3.3	<p><b>PCI Reset.</b> RESET# aborts all operations in progress and places the AMD Geode LX processor into a reset state. RESET# forces the CPU and peripheral functions to begin executing at a known state. All data in the on-chip cache is invalidated upon a reset.</p> <p>RESET# is an asynchronous input, but must meet specified setup and hold times to guarantee recognition at a particular clock edge. This input is typically generated during the power-on-reset (POR) sequence.</p>
STOP#	AJ25	I/O	33-66 Mb/s	3.3	<p><b>Target Stop.</b> STOP# is asserted to indicate that the current target is requesting the master to stop the current transaction. This signal is used with DEVSEL# to indicate retry, disconnect, or target abort. If STOP# is sampled active while a master, FRAME# is de-asserted and the cycle is stopped within three SYSREFs. STOP# can be asserted when the PCI write buffers are full or a previously buffered cycle has not completed.</p>
FRAME#	AL28	I/O	33-66 Mb/s	3.3	<p><b>Frame.</b> FRAME# is driven by the current master to indicate the beginning and duration of an access. FRAME# is asserted to indicate a bus transaction is beginning. While FRAME# is asserted, data transfers continue. When FRAME# is de-asserted, the transaction is in the final data phase.</p>
IRDY#	AH25	I/O	33-66 Mb/s	3.3	<p><b>Initiator Ready.</b> IRDY# is asserted to indicate that the bus master is able to complete the current data phase of the transaction. IRDY# is used in conjunction with TRDY#. A data phase is completed on any SYSREF in which both IRDY# and TRDY# are sampled asserted. During a write, IRDY# indicates valid data is present on AD[31:0]. During a read, it indicates the master is prepared to accept data. Wait cycles are inserted until both IRDY# and TRDY# are asserted together.</p>
TRDY#	AK26	I/O	33-66 Mb/s	3.3	<p><b>Target Ready.</b> TRDY# is asserted to indicate that the target agent is able to complete the current data phase of the transaction. TRDY# is used in conjunction with IRDY#. A data phase is complete on any SYSREF in which both TRDY# and IRDY# are sampled asserted. During a read, TRDY# indicates that valid data is present on AD[31:0]. During a write, it indicates the target is prepared to accept data. Wait cycles are inserted until both IRDY# and TRDY# are asserted together.</p>

## 3.4.5 PCI Interface Signals (Continued)

Signal Name	Ball No.	Type	f	V	Description
DEVSEL#	AK25	I/O	33-66 Mb/s	3.3	<b>Device Select.</b> DEVSEL# indicates that the driving device has decoded its address as the target of the current access. As an input, DEVSEL# indicates whether any device on the bus has been selected. DEVSEL# is also driven by any agent that has the ability to accept cycles on a subtractive decode basis. As a master, if no DEVSEL# is detected within and up to the subtractive decode clock, a master abort cycle results, except for special cycles that do not expect a DEVSEL# returned.
REQ[2:0]#	AB28, AB31, AA29	I	33-66 Mb/s	3.3	<b>Request Lines.</b> REQ# indicates to the arbiter that an agent desires use of the bus. Each master has its own REQ# line. REQ# priorities are based on the arbitration scheme chosen.  REQ2# is reserved for the interface with the AMD Geode CS5536 companion device.
GNT[2:0]#	AC30, AB30, AA28 (Strap)	I/O	33-66 Mb/s	3.3	<b>Grant Lines.</b> GNT# indicates to the requesting master that it has been granted access to the bus. Each master has its own GNT# line. GNT# can be pulled away any time a higher REQ# is received or if the master does not begin a cycle within a set period of time.  GNT# is an output during normal operation. It is an input at reset and functions as a boot strap for frequency selection on a board. It must be pulled high or low to invoke the strap.  GNT2# is reserved for the interface with the AMD Geode CS5536 companion device.

## 3.4.6 TFT Display Interface Signals

Signal Name	Ball No.	Type	f	V	Description
DRGB[31:24] DRGB[23:0]	See Table 3-6 on page 30	I/O O (PD)	0-162 Mb/s	3.3	<b>Display Data Bus.</b>
DOTCLK	AE1	O (PD)	0-162 MHz	3.3	<b>Dot Clock.</b> Output clock from DOTCLK PLL.
HSYNC	AE3	O (PD)	0-162 Mb/s	3.3 (5vt)	<b>Horizontal Sync.</b> Horizontal Sync establishes the line rate and horizontal retrace interval for an attached flat panel. The polarity is programmable (See Section 6.8.3.43 on page 451, VP Memory Offset 400h[29]).
VSYNC	AD3	O (PD)	0-162 Mb/s	3.3 (5vt)	<b>Vertical Sync.</b> Vertical Sync establishes the screen refresh rate and vertical retrace interval for an attached flat panel. The polarity is programmable (See Section 6.8.3.43 on page 451, VP Memory Offset 400h[30]).
DISPEN	AE4	O (PD)	0-162 Mb/s	3.3	<b>Flat Panel Backlight Enable.</b>
VDDEN	AE2	I/O (PD)	0-162 Mb/s	3.3	<b>LCD VDD FET Control.</b> When this output is asserted high, V <sub>DD</sub> voltage is applied to the panel. This signal is intended to control a power FET to the LCD panel. The FET may be internal to the panel or not, depending on the panel manufacturer.
LDEMOD	AD4	I/O (PD)	0-162 Mb/s	3.3	<b>Flat Panel Display Enable (TFT Panels).</b>
MSGSTART	AH11	I	0-75 Mb/s	3.3	<b>Message Start.</b> Used in VIP message passing mode to indicate start of message.
MSGSTOP	AJ11	I	0-75 Mb/s	3.3	<b>Message Stop.</b> Used in VIP message passing mode to indicate end of message.
VID[15:8]	See Table 3-6 on page 30	I (PD)	0-75 Mb/s	3.3	<b>Video Input Port Data.</b> When in 16 bit VIP mode, these are the eight MSBs of the VIP data.
VOP[15:0]	See Table 3-6 on page 30	O	0-75 Mb/s	3.3	<b>Video Output Port Data.</b> VOP output data.
VOPCLK	AE1	O	0-75 MHz	3.3	<b>Video Output Port Clock.</b>
VOP_BLANK	AE4	O	0-75 Mb/s	3.3	<b>Video Output Port Blank.</b>
VOP_HSYNC	AE3	O	0-75 Mb/s	3.3	<b>Video Output Port Horizontal Sync.</b>
VOP_VSYNC	AD3	O	0-75 Mb/s	3.3	<b>Video Output Port Vertical Sync.</b>



### 3.4.7 CRT Display Interface Signals

Signal Name	Ball No.	Type	f	V	Description
HSYNC	AE3	I/O	0-350 Mb/s	3.3 (5vt)	<b>Horizontal Sync.</b> Horizontal Sync establishes the line rate and horizontal retrace interval for an attached CRT. The polarity is programmable (See Section 6.8.3.2 on page 422, VP Memory Offset 008h[8]).
VSYNC	AD3	I/O	0-350 Mb/s	3.3 (5vt)	<b>Vertical Sync.</b> Vertical Sync establishes the screen refresh rate and vertical retrace interval for an attached CRT. The polarity is programmable (See Section 6.8.3.2 on page 422, VP Memory Offset 008h[9]).
DVREF	W1	A	Analog	1.235	<b>Video DAC Voltage Reference.</b> Connect this pin to a 1.235V voltage reference.
DRSET	Y1	A	Analog	N/A	<b>DAC Current Setting Resistor.</b> 1.21K, 1% to DAV <sub>SS</sub> .
DAV <sub>DD</sub> [3:0]	W4, V4, V1, U1	APWR	Analog	3.3	<b>DAC Analog Power Connection.</b>
DAV <sub>SS</sub> [3:0]	W2, Y2, V3, U3	AGND	Analog	0	<b>DAC Analog Ground Connection.</b>
RED	W3	A	Analog	N/A	<b>Red DAC Output.</b> Red analog output.
GREEN	V2	A	Analog	N/A	<b>Green DAC Output.</b> Green analog output.
BLUE	U2	A	Analog	N/A	<b>Blue DAC Output.</b> Blue analog output.

### 3.4.8 VIP Interface Signals

Signal Name	Ball No.	Type	f	V	Description
VIPCLK	AL12	I/O (PD)	0-75 MHz	3.3	<b>Video Input Port Clock.</b>
VID[7:0]	AK12, AL13, AK13, AJ13, AH13, AL15, AK15, AJ15	I/O (PD)	0-150 Mb/s	3.3	<b>Video Input Port Data.</b>
VIPSYNC	AL14	I/O (PD)	0-150 Mb/s	3.3	<b>Video Input Port Sync Signal.</b>
VIP_HSYNC	AE2	I	0-150 Mb/s	3.3	<b>Video Input Port Horizontal Sync.</b>
VIP_VSYNC	AD4	I	0-150 Mb/s	3.3	<b>Video Input Port Vertical Sync.</b>

### 3.4.9 Power and Ground Interface Signals

Signal Name (Note 1)	Ball No.	Type	f	V	Description
V <sub>CORE</sub>	See Table 3-6 on page 30	PWR	N/A	1.2	<b>Core Power Connection (Total of 32).</b>
V <sub>IO</sub>	See Table 3-6 on page 30	PWR	N/A	3.3	<b>I/O Power Connection (Total of 30)</b>
V <sub>MEM</sub>	See Table 3-6 on page 30	PWR	N/A	2.5	<b>Memory Power Connection (Total of 33).</b>
V <sub>SS</sub>	See Table 3-6 on page 30	GND	N/A	0	<b>Ground Connection (Total of 128).</b>

Note 1. For module specific power and ground signals see:  
 Section 3.4.2 "PLL Interface Signals" on page 34  
 Section 3.4.7 "CRT Display Interface Signals" on page 41

For additional electrical details on pins, refer to Section 7.0 "Electrical Specifications" on page 597.

Table 3-7. Signal Behavior During and After Reset

Signal Name	Type	Behavior
AD[31:0]	PCI	TRI-STATE during RESET# low
INTA#		
PAR		
REQ#		
IRDY#		
FRAME#		
GNT#		
DEVSEL#		
TRDY#		
STOP#		
BA[1:0]		
CAS[1:0]#		
CBE[3:0]#		
CS[3:0]#		
DQ[63:0]		
DQM[7:0]		
DQS[7:0]		
MA[13:0]		
RAS[1:0]#		
SDCLK[5:0]P		
SDCLK[5:0]N		
TLA[1:0]		
WE[1:0]#		
TDO	Debug	
TDBGO		
VIPSYNC (PD)	VIP	
IRQ13	System	
SUSPA#		
DRGB[31:24]	Video	PD during reset.
VSYNC	Video	Driven low during RESET# low
HSYNC		
DISPEN		
DOTCLK		
DRGB[23:0]		
LDEMOD		
VDDEN		
CKE[1:0]#		

Signal Name	Type	Behavior	
VID[7:0] (PD)	Video	Inputs during RESET# low	
VIPCLK			
CIS	System		
TDBGI	Debug		
TMS			
TDI			
TCLK			
SYREF	System		
DOTREF			
Power-up states after RESET#			
DRGB[31:24]	Video	TRI-STATE with pin PD: — Display filter can enable outputs to drive alpha (disables PDs). — VIP can enable as inputs (disables PDs).	
DRGB[23:0]		Driven	
DOTCLK			
HSYNC			
VSYNC			
DISPEN			
VDDEN		Input with PD	
LDEMOD			
VID[7:0]			
VIPCLK			
VIPSYNC		Input with PD: — PD remains if pin is used as input. — PD disables if VIP drives pin.	
PW[1:0]		System	TRI-STATE



# GeodeLink™ Interface Unit

# 4

Many traditional architectures use buses to connect modules together, which usually requires unique addressing for each register in every module. This requires that some kind of house-keeping be done as new modules are designed and new devices are created from the module set. Using module select signals to create the unique addresses can get cumbersome and requires that the module selects be sourced from some centralized location.

To alleviate this issue, AMD developed an internal bus architecture based on GeodeLink™ technology. The GeodeLink architecture connects the internal modules of a device using the data ports provided by GeodeLink Interface Units (GLIUs). Using GLIUs, all internal module port addresses are derived from the distinct port that the module is connected to. In this way, a module's Model Specific Registers (MSRs) do not have unique addresses until a device is defined. Also, as defined by the GeodeLink architecture, a module's port address depends on the location of the module sourcing the cycle, or source module (e.g., source module can be CPU Core, GLCP, and GLPCI; however, under normal operating conditions, accessing MSRs is from the CPU Core).

## 4.1 MSR Set

The AMD Geode™ LX processor incorporates two GLIUs into its device architecture. Except for the configuration registers that are required for x86 compatibility, all internal registers are accessed through a Model Specific Register (MSR) set. MSRs have a 32-bit address space and a 64-bit data space. The full 64-bit data space is always read or written when accessed.

An MSR can be read using the RDMSR instruction, opcode 0F32h. During an MSR read, the contents of the particular MSR, specified by the ECX register, are loaded into the EDX:EAX registers. An MSR can be written using the WRMSR instruction, opcode 0F30h. During an MSR write, the contents of EDX:EAX are loaded into the MSR specified in the ECX register. The RDMSR and WRMSR instructions are privileged instructions.

Table 4-1 shows the MSR port address to access the modules within the AMD Geode LX processor with the CPU Core as the source module.

**Table 4-1. MSR Addressing**

Module Name	GLIU	Port	MSR Address (Relative to CPU Core)
GeodeLink™ Interface Unit 0 (GLIU0)	0	0	1000xxxxh
GeodeLink Memory Controller (GLMC)	0	1	2000xxxxh
CPU Core (CPU Core)	0	3	0000xxxxh
Display Controller (DC)	0	4	8000xxxxh
Graphics Processor (GP)	0	5	A000xxxxh
GeodeLink Interface Unit 1 (GLIU1)	1	0	4000xxxxh
Video Processor (VP)	1	2	4800xxxxh
GeodeLink Control Processor (GLCP)	1	3	4C00xxxxh
GeodeLink PCI Bridge (GLPCI)	1	4	5000xxxxh
Video Input Port (VIP)	1	5	5400xxxxh
Security Block (SB)	1	6	5800xxxxh

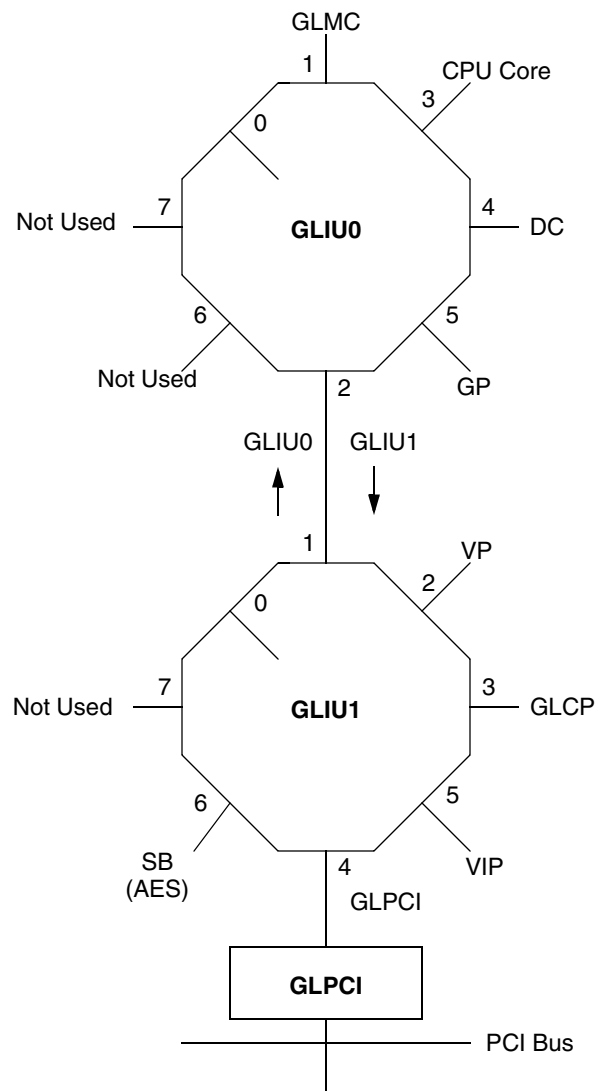
**4.1.1 Port Address**

Each GLIU has seven channels with Channel 0 being the GLIU itself and therefore not considered a physical port. Figure 4-1 illustrates the GeodeLink architecture in a AMD Geode LX processor, showing how the modules are connected to the two GLIUs. GLIU0 has five channels connected, and GLIU1 has six channels connected. To get MSR address/data across the PCI bus, the GLPCI converts the MSR address into PCI cycles and back again.

An MSR address is parsed into two fields, the port address (18 bits) and the index (14 bits). The port address is further parsed into six 3-bit channel address fields. Each 3-bit field represents, from the perspective of the source module, the GLIU channels that are used to get to the destination module, starting from the closest GLIU to the source (left most 3-bit field) to the farthest GLIU (right most 3-bit field).

In an AMD Geode LX processor/CS5536 system, the companion device is connected to the processor via the PCI bus. The internal architecture of the companion device uses the same GeodeLink architecture with one GLIU being in that device. Hence, in a AMD Geode LX processor/CS5536 system there are a total of three GLIUs: two in the processor and one in the companion device. Therefore at most, only the two left most 3-bit fields of the base address field should be needed to access any module in the system. There are exceptions that require more; see Section 4.1.2 "Port Addressing Exceptions" on page 47. For the CPU Core to access MSR Index 300h in the GeodeLink Control Processor (GLCP) module, the address is 010\_011\_000\_000\_000\_000b (six channel fields of the port address) + 300h (Index), or 4C000300h. The 010b points to Channel 2 of GLIU0, which is the channel connected to GLIU1. The 011b points to the GLIU1 Channel 3, which is the channel to the GLCP module. From this point on, the port address is abbreviated by noting each channel address followed by a dot. From the above example, this is represented by 2.3.0.0.0.0. It is important to repeat here that the port address is derived from the perspective of the source module.

For a module to access an MSR within itself, the port address is zero.



**Figure 4-1. GeodeLink™ Architecture**

### 4.1.2 Port Addressing Exceptions

There are some exceptions to the port addressing rules.

If a module accesses an MSR from within its closest GLIU (e.g., CPU Core accessing a GLIU0 MSR), then, by convention, the port address should be 0.0.0.0.0.0. But this port address accesses an MSR within the source module and not the GLIU as desired. To get around this, if the port address contains a 0 in the first channel field and then contains a 1 in any of the other channel fields, the access goes to the GLIU nearest the module sourcing the cycle. By convention, set the MSB of the second channel field, 0.4.0.0.0.0. If the MSR access is to a GLIU farther removed from the module sourcing the cycle, then there is no convention conflict, so no exception is required for that situation.

If a module attempts to access an MSR to the channel that it is connected to, a GLIU error results. This is called a reflective address attempt. An example of this case is the CPU Core accessing 3.0.0.0.0.0. Since the CPU Core is connected to Channel 3 of GLIU0, the access causes a reflective address error. This exception is continued to the next GLIU in the chain. The CPU Core accessing 2.1.0.0.0.0 also causes a reflective address error.

To access modules in the AMD Geode companion device, the port address must go through the GLPCI (PCI controller) in the processor and through the GLPCI in the companion device. The port address of the MSRs in the processor's GLPCI when accessed from the CPU Core is 2.4.0.0.0.0. To get the port address to go through the GLPCI, the third field needs a non-zero value. By convention, this is a 2. We now have a port address of 2.4.2.0.0.0. But this accesses the MSRs in the GLPCI in the companion device. The port to be accessed must be added in the fourth field, 2.4.2.5.0.0, to access the AC97 audio bus master, for example.

To access the GLIU in the companion device, the same addressing exception occurs as with GLIU0 due to the GLPCI's address. A port address of 2.4.2.0.0.0 accesses the companion device's GLPCI, not the GLIU. To solve this, a non-zero value must be in at least one of the two right-most port fields. By convention, a 4 in the left-most port field is used. To access the companion device's GLIU from the CPU Core, the port address is 2.4.2.0.0.4.

Table 4-2 shows the MSR port address to access all the modules in a AMD Geode LX processor/CS5536 system with the CPU Core as the source module. Included in the table is the MSR port address for module access using the GLCP and GLPCI as the source module. However, under normal operating conditions, accessing MSRs is from the CPU Core. Therefore, all MSR addresses in the following chapters of this data book are documented using the CPU Core as the source.

**Table 4-2. MSR Mapping**

Destination	Source (Note 1)		
	CPU Core	GLCP	GLPCI
CPU Core	0000xxxxh	2C00xxxxh	2C00xxxxh
GLIU0	1000xxxxh	2000xxxxh	2000xxxxh
GLMC	2000xxxxh	2400xxxxh	2400xxxxh
GLIU1	4000xxxxh	1000xxxxh	1000xxxxh
GLCP	4C00xxxxh	0000xxxxh	6000xxxxh
GLPCI	5000xxxxh	8000xxxxh	0000xxxxh
DC	8000xxxxh	3000xxxxh	3000xxxxh
GP	A000xxxxh	3400xxxxh	3400xxxxh
VP	4800xxxxh	4000xxxxh	3800xxxxh
VIP	5400xxxxh		
Security Block	5800xxxxh		
Companion Device	51Y0xxxxh (Note 2)	8ZK0xxxxh (Note 3)	NA

- Note 1. The xxxx contains the lower two bits of the 18 bits from the port fields plus the 14-bit MSR offset.
- Note 2. Y is the hex value obtained from one bit (always a 0) plus the port number (#) of the six port field addresses [0+#]. Example: # = 5, therefore the Y value is [0+101] which is 5h, thus the address = 5150xxxxh.
- Note 3. ZK are the hex values obtained from the concatenation of [10+#+000], where # is the port number from the six port field address. Example # = 5, the ZK value is [10+101+000] which is [1010,1000]. In hex. it is A8h; thus the address is 8A80xxxxh.

### 4.1.3 Memory and I/O Mapping

The GLIU decodes the destination ID of memory requests using a series of physical to device (P2D) descriptors. There can be up to 32 descriptors in each GLIU. The GLIU decodes the destination ID of I/O requests using a series of I/O descriptors (IOD).

#### 4.1.3.1 Memory Routing and Translation

Memory addresses are routed and optionally translated from physical space to device space. Physical space is the 32-bit memory address space that is shared between all GeodeLink devices. Device space is the unique address space within a given device. For example, a memory controller may implement a 4 MB frame buffer region in the 12-16 MB range of main memory. However, the 4 MB region may exist in the 4 GB region of physical space. The actual location of the frame buffer in the memory controller with respect to itself is a device address, while the address that all the devices see in the region of memory is in physical space.

Memory request routing and translation is performed with a choice of five descriptor types. Each GLIU may have any number of each descriptor type up to a total of 32. The P2D descriptor types satisfy different needs for various software models.

Each memory request is compared against all the P2D descriptors. If the memory request does not hit in any of the descriptors, the request is sent to the subtractive port. If the memory requests hit more than one descriptor, the results are undefined. The software must provide a consistent non-overlapping address map.

The way each descriptor checks if the request address hits its descriptor and how to route the request address to the device address is described in Table 4-3.

#### P2D Base Mask Descriptor (P2D\_BM)

P2D\_BM is the simplest descriptor. It usually maps a power of two size aligned region of memory to a destination ID. P2D\_BM performs no address translation.

#### P2D Base Mask Offset Descriptor (P2D\_BMO)

P2D\_BMO has the same routing features as P2D\_BM with the addition of a 2s complement address translation to the most-significant bits of the address.

#### P2D Range Descriptor (P2D\_R)

P2D\_R maps a range of addresses to a device that is NOT a power of 2 size aligned. There is no address translation (see Table 4-3).

#### P2D Range Offset Descriptor (P2D\_RO)

P2D\_RO has the same address routing as P2D\_R with the addition of address translation with a 2s complement offset.

#### P2D Swiss Cheese Descriptor (P2D\_SC)

The P2D\_SC maps a 256 KB region of memory in 16 KB chunks to a device or the subtractive decode port. The descriptor type is useful for legacy address mapping. The Swiss cheese feature implies that the descriptor is used to “poke holes” in memory.

**Note:** Only one P2D can hit at a time for a given port. If the P2D descriptors are overlapping, the results are undefined.

**Table 4-3. GLIU Memory Descriptor Address Hit and Routing Description**

Descriptor	Function Description
P2D_BM, P2D_BMO	<p>Checks that the physical address supplied by the device's request on address bits [31:12] with a logical AND with PMASK bits of the descriptor register bits [19:0] are equal to the PBASE bits on the descriptor register (bits [39:20]).</p> <p>Also checks that the BIZZARO bit of the request is equal to the PCMP_BIZ bit of the descriptor register bit [60].</p> <p>If the above matches, then the descriptor has a hit condition and it routes the received address to the programmed destination PDID1 of the descriptor register (bits [63:61]).</p> <p>For P2D_BM: DEVICE_ADDR = request address</p> <p>For P2D_BMO: DEVICE_ADDR [31:12] = [request address [31:12] + descriptor POFFSET] DEVICE_ADDR [11:0] = request address [11:0]</p>
P2D_R, P2D_RO	<p>Checks that the physical address supplied by the device's request on address bits [31:12] are within the range specified by PMIN and PMASK field bits [39:20] and [19:0], respective of the descriptor register. PMIN is the minimum address range and PMAX is the maximum address range. The condition is: <math>PMAX &gt; \text{physical address [31:12]} &gt; PMIN</math>.</p> <p>Also checks that the BIZZARO bit of the request is equal to the PCMP_BIZ bit of the descriptor register bit [60].</p> <p>If the above matches, then the descriptor has a hit condition and routes the received address to the programmed destination ID, PDID1 of the descriptor register (bits [63:61]).</p> <p>For P2D_R: DEVICE_ADDR = request address</p> <p>For P2D_RO: DEVICE_ADDR [31:12] = [request address [31:12] + descriptor POFFSET] DEVICE_ADDR [11:0] = request address [11:0]</p>
P2D_SC	<p>Checks that the physical address supplied by the device's request on address bits [31:18] are equal to the PBASE field of descriptor register bits [13:0] and that the enable write or read conditions given by the descriptor register fields WEN and REN in bits [47:32] and [31:16], respectively matches the request type and enable fields given on the physical address bits [17:14] of the device's request.</p> <p>If the above matches, then the descriptor has a hit condition and routes the received address to the programmed destination ID, PDID1 field of the descriptor register bits [63:61].</p> <p>DEVICE_ADDR = request address</p>



### 4.1.3.2 I/O Routing and Translation

I/O addresses are routed and are never translated. I/O request routing is performed with a choice of two descriptor types. Each GLIU may have any number of each descriptor type. The IOD types satisfy different needs for various software models.

Each I/O request is compared against all the IOD. If the I/O request does not hit in any of the descriptors, the request is sent to the subtractive port. If the I/O request hits more than one descriptor, the results are undefined. Software must provide a consistent non-overlapping I/O address map. The methods of check and routing are described in Table 4-4.

#### IOD Base Mask Descriptors (IOD\_BM)

IOD\_BM is the simplest descriptor. It usually maps a power of two size aligned region of I/O to a destination ID.

#### IOD Swiss Cheese Descriptors (IOD\_SC)

The IOD\_SC maps an 8-byte region of memory in 1 byte chunks to one of two devices. The descriptor type is useful

for legacy address mapping. The Swiss cheese feature implies that the descriptor is used to “poke holes” in I/O.

### 4.1.3.3 Special Cycles

PCI special cycles are performed using I/O writes and setting the BIZARRO flag in the write request. The BIZARRO flag is treated as an additional address bit, providing unaliased I/O address. The I/O descriptors are set up to route the special cycles to the appropriate device (i.e., GLCP, GLPCI, etc.). The I/O descriptors are configured to default to the appropriate device on reset. The PCI special cycles are mapped as:

Name	BIZZARO	Address
Shutdown	1	00000000h
Halt	1	00000001h
x86 specific	1	00000002h
0003h-FFFFh	1	00000002h-0000FFFFh

**Table 4-4. GLIU I/O Descriptor Address Hit and Routing Description**

Descriptor	Function Description
IOD_BM	<p>Checks that the physical address supplied by the device on address bits [31:12] with a logic AND with PMASK bits of the register bits [19:0] are equal to the PBASE bits of the descriptor register bits [39:20].</p> <p>Also checks that the BIZZARO bit of the request is equal to the PCMP_PIZ bit of the descriptor register bit [60].</p> <p>If the above matches, then the descriptor has a hit condition and routes the received address to the programmed destination of the P2D_BM register bit [63:61].</p> <p>DEVICE_ADDR = request address</p>
IOD_SC	<p>Checks that the physical address supplied by the device’s request on address bits [31:18] are equal to the PBASE field of descriptor register bits [13:0] and that the enable write or read conditions given by the descriptor register fields WEN and REN in bits [47:32] and [31:16], respectively matches the request type and enable fields given on the physical address bits [17:14] of the device’s request.</p> <p>If the above matches, then the descriptor has a hit condition and routes the received address to the programmed destination ID, PDID1 field of the descriptor register bits [63:61].</p> <p>DEVICE_ADDR = request address</p>

## 4.2 GLIU Register Descriptions

All GeodeLink™ Interface Unit (GLIU) registers are Model Specific Registers (MSRs) and are accessed through the RDMSR and WRMSR instructions.

The registers associated with the GLIU are the Standard GeodeLink Device (GLD) MSRs, GLIU Specific MSRs, GLIU Statistic and Comparator MSRs, P2D Descriptor MSRs, and I/O Descriptor MSRs. The tables that follow are

register summary tables that include reset values and page references where the bit descriptions are provided.

**Note:** The MSR address is derived from the perspective of the CPU Core. See Section 4.1 "MSR Set" on page 45 for more details on MSR addressing.

Reserved (RSVD) fields do not have any meaningful storage elements. They always return 0.

**Table 4-5. GeodeLink™ Device Standard MSRs Summary**

MSR Address	Type	Register Name	Reset Value	Reference
GLIU0: 10002000h GLIU1: 40002000h	RO	GLD Capabilities MSR (GLD_MSR_CAP)	00000000_000014xxh	Page 55
GLIU0: 10002001h GLIU1: 40002001h	R/W	GLD Master Configuration MSR (GLD_MSR_CONFIG)	GLIU0: 00000000_00000002h GLIU1: 00000000_00000004h	Page 55
GLIU0: 10002002h GLIU1: 40002002h	R/W	GLD SMI MSR (GLD_MSR_SMI)	00000000_00000001h	Page 56
GLIU0: 10002003h GLIU1: 40002003h	R/W	GLD Error MSR (GLD_MSR_ERROR)	00000000_00000000h	Page 57
GLIU0: 10002004h GLIU1: 40002004h	R/W	GLD Power Management MSR (GLD_MSR_PM)	00000000_00000000h	Page 59
GLIU0: 10002005h GLIU1: 40002005h	R/W	GLD Diagnostic MSR (GLD_MSR_DIAG)	00000000_00000000h	Page 60

**Table 4-6. GLIU Specific MSRs Summary**

MSR Address	Type	Register Name	Reset Value	Reference
GLIU0: 10000080h GLIU1: 40000080h	R/W	Coherency (COH)	Configuration Dependent	Page 60
GLIU0: 10000081h GLIU1: 40000081h	R/W	Port Active Enable (PAE)	Boot Strap Dependent	Page 61
GLIU0: 10000082h GLIU1: 40000082h	R/W	Arbitration (ARB)	10000000_00000000h	Page 62
GLIU0: 10000083h GLIU1: 40000083h	R/W	Asynchronous SMI (ASMI)	00000000_00000000h	Page 62
GLIU0: 10000084h GLIU1: 40000084h	R/W	Asynchronous ERR (AERR)	00000000_00000000h	Page 63
GLIU0: 10000086h GLIU1: 40000086h	R/W	GLIU Physical Capabilities (PHY_CAP)	GLIU0: 20291830_010C1086h GLIU1: 20311030_0100400Ah	Page 65
GLIU0: 10000087h GLIU1: 40000087h	RO	N Outstanding Response (NOUT_RESP)	00000000_00000000h	Page 66
GLIU0: 10000088h GLIU1: 40000088h	RO	N Outstanding Write Data (NOUT_WDATA)	00000000_00000000h	Page 67

Table 4-6. GLIU Specific MSRs Summary (Continued)

MSR Address	Type	Register Name	Reset Value	Reference
GLIU0: 10000089h GLIU1: 40000089h	RO	SLAVE_ONLY	GLIU0: 00000000_00000010h GLIU1: 00000000_00000100h	Page 67
GLIU0: 1000008Ah GLIU1: 4000008Ah	RO	Reserved	---	---
GLIU0: 1000008Bh GLIU1: 4000008Bh	RO	WHO AM I (WHOAMI)	Configuration Dependent	Page 68
GLIU0: 1000008Ch GLIU1: 4000008Ch	R/W	GLIU Slave Disable (GLIU_SLV)	00000000_00000000h	Page 69
GLIU0: 1000008Dh GLIU1: 4000008Dh	R/W	Arbitration2 (ARB2)	00000000_00000000h	Page 70

Table 4-7. GLIU Statistic and Comparator MSRs Summary

MSR Address	Type	Register	Reset Value	Reference
GLIU0: 100000A0h GLIU1: 400000A0h	WO	Descriptor Statistic Counter (STATISTIC_CNT[0])	00000000_00000000h	Page 71
GLIU0: 100000A1h GLIU1: 400000A1h	R/W	Descriptor Statistic Mask (STATISTIC_MASK[0])	00000000_00000000h	Page 72
GLIU0: 100000A2h GLIU1: 400000A2h	R/W	Descriptor Statistic Action (STATISTIC_ACTION[0])	00000000_00000000h	Page 73
GLIU0: 100000A3h GLIU1: 400000A3h	--	Reserved	--	--
GLIU0: 100000A4h GLIU1: 400000A4h	WO	Descriptor Statistic Counter (STATISTIC_CNT[1])	00000000_00000000h	Page 71
GLIU0: 100000A5h GLIU1: 400000A5h	R/W	Descriptor Statistic Mask (STATISTIC_MASK[1])	00000000_00000000h	Page 72
GLIU0: 100000A6h GLIU1: 400000A6h	R/W	Descriptor Statistic Action (STATISTIC_ACTION[1])	00000000_00000000h	Page 73
GLIU0: 100000A7h GLIU1: 400000A7h	--	Reserved	--	--
GLIU0: 100000A8h GLIU1: 400000A8h	WO	Descriptor Statistic Counter (STATISTIC_CNT[2])	00000000_00000000h	Page 71
GLIU0: 100000A9h GLIU1: 400000A9h	R/W	Descriptor Statistic Mask (STATISTIC_MASK[2])	00000000_00000000h	Page 72
GLIU0: 100000AAh GLIU1: 400000AAh	R/W	Descriptor Statistic Action (STATISTIC_ACTION[2])	00000000_00000000h	Page 73
GLIU0: 100000ABh GLIU1: 400000ABh	--	Reserved	--	--
GLIU0: 100000ACh GLIU1: 400000ACh	WO	Descriptor Statistic Counter (STATISTIC_CNT[3])	00000000_00000000h	Page 71
GLIU0: 100000ADh GLIU1: 400000ADh	R/W	Descriptor Statistic Mask (STATISTIC_MASK[3])	00000000_00000000h	Page 72
GLIU0: 100000AEh GLIU1: 400000AEh	R/W	Descriptor Statistic Action (STATISTIC_ACTION[3])	00000000_00000000h	Page 73

Table 4-7. GLIU Statistic and Comparator MSRs Summary (Continued)

MSR Address	Type	Register	Reset Value	Reference
GLIU0: 10000C0h GLIU1: 40000C0h	R/W	Request Compare Value (RQ_COMPARE_VAL[0])	001FFFFFF_FFFFFFFFh	Page 74
GLIU0: 10000C1h GLIU1: 40000C1h	R/W	Request Compare Mask (RQ_COMPARE_MASK[0])	00000000_00000000h	Page 75
GLIU0: 10000C2h GLIU1: 40000C2h	R/W	Request Compare Value (RQ_COMPARE_VAL[1])	001FFFFFF_FFFFFFFFh	Page 74
GLIU0: 10000C3h GLIU1: 40000C3h	R/W	Request Compare Mask (RQ_COMPARE_MASK[1])	00000000_00000000h	Page 75
GLIU0: 10000C4h GLIU1: 40000C4h	R/W	Request Compare Value (RQ_COMPARE_VAL[2])	001FFFFFF_FFFFFFFFh	Page 74
GLIU0: 10000C5h GLIU1: 40000C5h	R/W	Request Compare Mask (RQ_COMPARE_MASK[2])	00000000_00000000h	Page 75
GLIU0: 10000C6h GLIU1: 40000C6h	R/W	Request Compare Value (RQ_COMPARE_VAL[3])	001FFFFFF_FFFFFFFFh	Page 74
GLIU0: 10000C7h GLIU1: 40000C7h	R/W	Request Compare Mask (RQ_COMPARE_MASK[3])	00000000_00000000h	Page 75
GLIU0: 10000C9h GLIU1: 40000CFh	--	Reserved	--	--
GLIU0: 10000D0h GLIU1: 40000D0h	R/W	Data Compare Value Low (DA_COMPARE_VAL_LO[0])	00001FFF_FFFFFFFFh	Page 76
GLIU0: 10000D1h GLIU1: 40000D1h	R/W	Data Compare Value High (DA_COMPARE_VAL_HI[0])	0000000F_FFFFFFFFh	Page 77
GLIU0: 10000D2h GLIU1: 40000D2h	R/W	Data Compare Mask Low (DA_COMPARE_MASK_LO[0])	00000000_00000000h	Page 78
GLIU0: 10000D3h GLIU1: 40000D3h	R/W	Data Compare Mask High (DA_COMPARE_MASK_HI[0])	00000000_00000000h	Page 79
GLIU0: 10000D4h GLIU1: 40000D4h	R/W	Data Compare Value Low (DA_COMPARE_VAL_LO[1])	00001FFF_FFFFFFFFh	Page 76
GLIU0: 10000D5h GLIU1: 40000D5h	R/W	Data Compare Value High (DA_COMPARE_VAL_HI[1])	0000000F_FFFFFFFFh	Page 77
GLIU0: 10000D6h GLIU1: 40000D6h	R/W	Data Compare Mask Low (DA_COMPARE_MASK_LO[1])	00000000_00000000h	Page 78
GLIU0: 10000D7h GLIU1: 40000D7h	R/W	Data Compare Mask High (DA_COMPARE_MASK_HI[1])	00000000_00000000h	Page 79
GLIU0: 10000DBh GLIU1: 40000DBh	R/W	Data Compare Value Low (DA_COMPARE_VAL_LO[2])	00000000_00000000h	Page 79
GLIU0: 10000D9h GLIU1: 40000D9h	R/W	Data Compare Value High (DA_COMPARE_VAL_HI[2])	0000000F_FFFFFFFFh	Page 77
GLIU0: 10000DAh GLIU1: 40000DAh	R/W	Data Compare Mask Low (DA_COMPARE_MASK_LO[2])	00000000_00000000h	Page 78
GLIU0: 10000DBh GLIU1: 40000DBh	R/W	Data Compare Mask High (DA_COMPARE_MASK_HI[2])	00000000_00000000h	Page 79
GLIU0: 10000DCh GLIU1: 40000DCh	R/W	Data Compare Value Low (DA_COMPARE_VAL_LO[3])	00001FFF_FFFFFFFFh	Page 76
GLIU0: 10000DDh GLIU1: 40000DDh	R/W	Data Compare Value High (DA_COMPARE_VAL_HI[3])	0000000F_FFFFFFFFh	Page 77

Table 4-7. GLIU Statistic and Comparator MSRs Summary (Continued)

MSR Address	Type	Register	Reset Value	Reference
GLIU0: 10000DEh GLIU1: 40000DEh	R/W	Data Compare Mask Low (DA_COMPARE_MASK_LO[3])	00000000_00000000h	Page 78
GLIU0: 10000DFh GLIU1: 40000DFh	R/W	Data Compare Mask High (DA_COMPARE_MASK_HI[3])	00000000_00000000h	Page 79

Table 4-8. GLIU P2D Descriptor MSRs Summary

MSR Address	Type	Register	Reset Value	Reference
<b>GLIU0</b>				
1000020h- 1000025h	R/W	P2D Base Mask Descriptor (P2D_BM): P2D_BM[5:0]	00000FF_FFF00000h	Page 80
1000026h- 1000027h	R/W	P2D Base Mask Offset Descriptor (P2D_BMO): P2D_BMO[1:0]	0000FF0_FFF00000h	Page 81
1000028h	R/W	P2D Range Descriptor (P2D_R: P2D_R[0])	00000000_000FFFFFh	Page 82
1000029h- 100002Bh	R/W	P2D Range Offset Descriptor (P2D_RO): P2D_RO[2:0]	00000000_000FFFFFh	Page 83
100002Ch	R/W	P2D Swiss Cheese Descriptor (P2D_SC): P2D_SC[0]	00000000_00000000h	Page 84
100002Dh- 100003Fh	R/W	P2D Reserved Descriptors	---	---
<b>GLIU1</b>				
4000020h- 4000029h	R/W	P2D Base Mask Descriptor (P2D_BM): P2D_BM[9:0]	00000FF_FFF00000h	Page 80
400002Ah- 400002Dh	R/W	P2D Range Descriptor (P2D_R): P2D_R[3:0]	00000000_000FFFFFh	Page 82
400002Eh	R/W	P2D Swiss Cheese Descriptor (P2D_SC): P2D_SC[0]	00000000_00000000h	Page 84
400002Fh- 400003Fh	R/W	P2D Reserved Descriptor (P2D_RSVD)	00000000_00000000h	---

Table 4-9. GLIU Reserved MSRs Summary

MSR Address	Type	Register	Reset Value	Reference
GLIU0: 1000006h- 100000Fh GLIU1: 4000006h- 400000Fh	R/W	Reserved for future use by AMD.	00000000_00000000h	---
GLIU0: 1000040h- 100004Fh GLIU1: 4000040h- 400004Fh	R/W	Reserved for future use by AMD.	00000000_00000000h	---
GLIU0: 1000050h- 100007Fh GLIU1: 4000050h- 400007Fh	R/W	Reserved for future use by AMD.	00000000_00000000h	---

Table 4-10. GLIU IOD Descriptor MSRs Summary

MSR Address	Type	Register	Reset Value	Reference
<b>GLIU0</b>				
100000E0h-100000E2h	R/W	IOD Base Mask Descriptors (IOD_BM)	000000FF_FFF00000h	Page 86
100000E3h-100000E8h	R/W	IOD Swiss Cheese Descriptors (IOD_SC)	00000000_00000000h	Page 87
100000E9h-100000FFh	R/W	IOD Reserved Descriptors	---	---
<b>GLIU1</b>				
400000E0h-400000E2h	R/W	IOD Base Mask Descriptors (IOD_BM)	000000FF_FFF00000h	Page 86
400000E3h-400000E6h	R/W	IOD Swiss Cheese Descriptors (IOD_SC)	00000000_00000000h	Page 87
400000E7h-400000FFh	R/W	IOD Reserved Descriptors	---	---

## 4.2.1 Standard GeodeLink™ Device (GLD) MSRs

### 4.2.1.1 GLD Capabilities MSR (GLD\_MSR\_CAP)

MSR Address GLIU0: 10002000h  
 GLIU1: 40002000h  
 Type RO  
 Reset Value 00000000\_000014xxh

**GLD\_MSR\_CAP Register Map**

63	62	61	60	59	58	57	56	55	54	53	52	51	50	49	48	47	46	45	44	43	42	41	40	39	38	37	36	35	34	33	32
RSVD																															
31	30	29	28	27	26	25	24	23	22	21	20	19	18	17	16	15	14	13	12	11	10	9	8	7	6	5	4	3	2	1	0
RSVD								DEV_ID																REV_ID							

**GLD\_MSR\_CAP Bit Descriptions**

Bit	Name	Description
63:24	RSVD	<b>Reserved.</b>
23:8	DEV_ID	<b>Device ID.</b> Identifies device (0014h).
7:0	REV_ID	<b>Revision ID.</b> Identifies device revision. See <i>AMD Geode™ LX Processors Specification Update</i> document for value

### 4.2.1.2 GLD Master Configuration MSR (GLD\_MSR\_CONFIG)

MSR Address GLIU0: 10002001h  
 GLIU1: 40002001h  
 Type R/W  
 Reset Value GLIU0: 00000000\_00000002h  
 GLIU1: 00000000\_00000004h

**GLD\_MSR\_CONFIG Register Map**

63	62	61	60	59	58	57	56	55	54	53	52	51	50	49	48	47	46	45	44	43	42	41	40	39	38	37	36	35	34	33	32
RSVD																															
31	30	29	28	27	26	25	24	23	22	21	20	19	18	17	16	15	14	13	12	11	10	9	8	7	6	5	4	3	2	1	0
																														SUBP	

**GLD\_MSR\_CONFIG Bit Descriptions**

Bit	Name	Description
63:3	RSVD	<b>Reserved.</b>
2:0	SUBP	<b>Subtractive Port.</b> Subtractive port assignment for all negative decode requests. 000: Port 0 (GLIU0 = GLIU; GLIU1 = GLIU) 001: Port 1 (GLIU0 = GLMC; GLIU1 = Interface to GLIU0) 010: Port 2 (GLIU0 = Interface to GLIU1; GLIU1 = VP) 011: Port 3 (GLIU0 = CPU Core; GLIU1 = GLCP) 100: Port 4 (GLIU0 = DC; GLIU1 = GLPCI) 101: Port 5 (GLIU0 = GP; GLIU1 = VIP) 110: Port 6 (GLIU0 = Not Used; GLIU1 = SB) 111: Port 7 (GLIU0 = Not Used; GLIU1 = Not Used)

**4.2.1.3 GLD SMI MSR (GLD\_MSR\_SMI)**

MSR Address      GLIU0: 10002002h  
                       GLIU1: 40002002h  
 Type                R/W  
 Reset Value        00000000\_00000001h

The flags are set with internal conditions. The internal conditions are always capable of setting the flag, but if the mask is 1, the flagged condition will not trigger the SMI signal. Reads to the flags return the value. Write = 1 to the flag, clears the value. Write = 0 has no effect on the flag.

**GLD\_MSR\_SMI Register Map**

63	62	61	60	59	58	57	56	55	54	53	52	51	50	49	48	47	46	45	44	43	42	41	40	39	38	37	36	35	34	33	32
RSVD																											SFLAG4	SFLAG3	SFLAG2	SFLAG1	SFLAG0
31	30	29	28	27	26	25	24	23	22	21	20	19	18	17	16	15	14	13	12	11	10	9	8	7	6	5	4	3	2	1	0
RSVD																											SMASK4	SMASK3	SMASK2	SMASK1	SMASK0

**GLD\_MSR\_SMI Bit Descriptions**

Bit	Name	Description
63:37	RSVD	<b>Reserved.</b>
36	SFLAG4	<b>SMI Flag4.</b> If high, records that an SMI was generated due to a Statistic Counter 3 (GLIU0 MSR 100000ACh, GLIU1 MSR 400000ACh) event. Write 1 to clear; writing 0 has no effect. SMASK4 (bit 4) must be low to generate SMI and set flag.
35	SFLAG3	<b>SMI Flag3.</b> If high, records that an SMI was generated due to a Statistic Counter 2 (GLIU0 MSR 100000A8h, GLIU1 MSR 400000A8h) event. Write 1 to clear; writing 0 has no effect. SMASK3 (bit 3) must be low to generate SMI and set flag.
34	SFLAG2	<b>SMI Flag2.</b> If high, records that an SMI was generated due to a Statistic Counter 1 (GLIU0 MSR 100000A4h, GLIU1 MSR 400000A4h) event. Write 1 to clear; writing 0 has no effect. SMASK2 (bit 2) must be low to generate SMI and set flag.
33	SFLAG1	<b>SMI Flag1.</b> If high, records that an SMI was generated due to a Statistic Counter 0 (GLIU0 MSR 100000A0h, GLIU1 MSR 400000A0h) event. Write 1 to clear; writing 0 has no effect. SMASK1 (bit 1) must be low to generate SMI and set flag.
32	SFLAG0	<b>SMI Flag0.</b> Unexpected Type (HW Emulation).
31:5	RSVD	<b>Reserved.</b>
4	SMASK4	<b>SMI Mask4.</b> Write 0 to enable SFLAG4 (bit 37) and to allow a Statistic Counter 3 (GLIU0 MSR 100000ACh, GLIU1 MSR 400000ACh) event to generate an SMI.
3	SMASK3	<b>SMI Mask3.</b> Write 0 to enable SFLAG3 (bit 36) and to allow a Statistic Counter 2 (GLIU0 MSR 100000A8h, GLIU1 MSR 400000A8h) event to generate an SMI.
2	SMASK2	<b>SMI Mask2.</b> Write 0 to enable SFLAG2 (bit 34) and to allow a Statistic Counter 1 (GLIU0 MSR 100000A4h, GLIU1 MSR 400000A4h) event to generate an SMI.
1	SMASK1	<b>SMI Mask1.</b> Write 0 to enable SFLAG1 (bit 33) and to allow a Statistic Counter 0 (GLIU0 MSR 100000A0h, GLIU1 MSR 400000A0h) event to generate an SMI.
0	SMASK0	<b>SMI Mask0.</b> Unexpected Type (HW Emulation).



#### 4.2.1.4 GLD Error MSR (GLD\_MSR\_ERROR)

MSR Address	GLIU0: 10002003h GLIU1: 40002003h
Type	R/W
Reset Value	00000000_00000000h

The flags are set with internal conditions. The internal conditions are always capable of setting the flag, but if the mask is 1, the flagged condition will not trigger the ERR signal. Reads to the flags return the value. Write = 1 to the flag, clears the value. Write = 0 has no effect on the flag.

**GLD\_MSR\_ERROR Register Map**

63	62	61	60	59	58	57	56	55	54	53	52	51	50	49	48	47	46	45	44	43	42	41	40	39	38	37	36	35	34	33	32											
RSVD																	EFLAG14	EFLAG13	EFLAG12	EFLAG11	EFLAG10	EFLAG9	EFLAG8	EFLAG7	EFLAG6	EFLAG5	EFLAG4	EFLAG3	EFLAG2	EFLAG1	EFLAG0											
31	30	29	28	27	26	25	24	23	22	21	20	19	18	17	16	15	14	13	12	11	10	9	8	7	6	5	4	3	2	1	0											
RSVD																	EMASK14	EMASK13	EMASK12	EMASK11	EMASK10	EMASK9	EMASK8	EMASK7	EMASK6	EMASK5	EMASK4	EMASK3	EMASK2	EMASK1	EMASK0											

**GLD\_MSR\_ERROR Bit Descriptions**

Bit	Name	Description
63:47	RSVD	<b>Reserved.</b>
46	EFLAG14	<b>Data Comparator Error Flag 3.</b> If high, records that an ERR was generated due to a Data Comparator 3 (DA_COMPARE_VAL_LO3/DA_COMPARE_VAL_HI3, GLIU0 MSR 100000DCh/100000DDh, GLIU1 MSR 400000DCh/400000DDh) event. Write 1 to clear; writing 0 has no effect. EMASK14 (bit 14) must be low to generate ERR and set flag.
45	EFLAG13	<b>Data Comparator Error Flag 2.</b> If high, records that an ERR was generated due to a Data Comparator 2 (DA_COMPARE_VAL_LO2/DA_COMPARE_VAL_HI2, GLIU0 MSR 100000D8h/100000D9h, GLIU1 MSR 400000D8h/400000D9h) event. Write 1 to clear; writing 0 has no effect. EMASK13 (bit 13) must be low to generate ERR and set flag.
44	EFLAG12	<b>Data Comparator Error Flag 1.</b> If high, records that an ERR was generated due to a Data Comparator 1 (DA_COMPARE_VAL_LO1/DA_COMPARE_VAL_HI1, GLIU0 MSR 100000D4h/100000D5h, GLIU1 MSR 400000D4h/400000D5h) event. Write 1 to clear; writing 0 has no effect. EMASK12 (bit 12) must be low to generate ERR and set flag.
43	EFLAG11	<b>Data Comparator Error Flag 0.</b> If high, records that an ERR was generated due to a Data Comparator 0 (DA_COMPARE_VAL_LO0/DA_COMPARE_VAL_HI0, GLIU0 MSR 100000D0h/100000D1h, GLIU1 MSR 400000D0h/400000D1h) event. Write 1 to clear; writing 0 has no effect. EMASK11 (bit 11) must be low to generate ERR and set flag.
42	EFLAG10	<b>Request Comparator Error Flag 3.</b> If high, records that an ERR was generated due to a Request Comparator 3 (RQ_COMPARE_VAL3, GLIU0 MSR 100000C6h, GLIU1 MSR 400000C6h) event. Write 1 to clear; writing 0 has no effect. EMASK10 (bit 10) must be low to generate ERR and set flag.
41	EFLAG9	<b>Request Comparator Error Flag 2.</b> If high, records that an ERR was generated due to a Request Comparator 2 (RQ_COMPARE_VAL2, GLIU0 MSR 100000C4h, GLIU1 MSR 400000C4h) event. Write 1 to clear; writing 0 has no effect. EMASK9 (bit 9) must be low to generate ERR and set flag.
40	EFLAG8	<b>Request Comparator Error Flag 1.</b> If high, records that an ERR was generated due to a Request Comparator 1 (RQ_COMPARE_VAL1, GLIU0 MSR 100000C2h, GLIU1 MSR 400000C2h) event. Write 1 to clear; writing 0 has no effect. EMASK8 (bit 8) must be low to generate ERR and set flag.

## GLD\_MSR\_ERROR Bit Descriptions (Continued)

Bit	Name	Description
39	EFLAG7	<b>Request Comparator Error Flag 0.</b> If high, records that an ERR was generated due to a Request Comparator 0 (RQ_COMPARE_VAL0, GLIU0 MSR 100000C0h, GLIU1 MSR 400000C0h) event. Write 1 to clear; writing 0 has no effect. EMASK7 (bit 7) must be low to generate ERR and set flag.
38	EFLAG6	<b>Statistic Counter Error Flag 3.</b> If high, records that an ERR was generated due to a Statistic Counter 3 (GLIU0 MSR 100000ACh, GLIU1 MSR 400000ACh) event. Write 1 to clear; writing 0 has no effect. EMASK6 (bit 6) must be low to generate ERR and set flag.
37	EFLAG5	<b>Statistic Counter Error Flag 2.</b> If high, records that an ERR was generated due to a Statistic Counter 2 (GLIU0 MSR 100000A8h, GLIU1 MSR 400000A8h) event. Write 1 to clear; writing 0 has no effect. EMASK5 (bit 5) must be low to generate ERR and set flag.
36	EFLAG4	<b>Statistic Counter Error Flag 1.</b> If high, records that an ERR was generated due to a Statistic Counter 1 (GLIU0 MSR 100000A4h, GLIU1 MSR 400000A4h) event. Write 1 to clear; writing 0 has no effect. EMASK4 (bit 4) must be low to generate ERR and set flag.
35	EFLAG3	<b>Statistic Counter Error Flag 0.</b> If high, records that an ERR was generated due to a Statistic Counter 0 (GLIU0 MSR 100000A0h, GLIU1 MSR 400000A0h) event. Write 1 to clear; writing 0 has no effect. EMASK3 (bit 3) must be low to generate ERR and set flag.
34	EFLAG2	<b>Unhandled SMI Error Flag.</b> If high, records that an ERR was generated due an unhandled SSMI (synchronous error). Write 1 to clear; writing 0 has no effect. EMASK2 (bit 2) must be low to generate ERR and set flag Unhandled SMI.
33	EFLAG1	<b>Unexpected Address Error Flag.</b> If high, records that an ERR was generated due an unexpected address (synchronous error). Write 1 to clear; writing 0 has no effect. EMASK1 (bit 1) must be low to generate ERR and set flag.
32	EFLAG0	<b>Unexpected Type Error Flag.</b> If high, records that an ERR was generated due an unexpected type (synchronous error). Write 1 to clear; writing 0 has no effect. EMASK0 (bit 0) must be low to generate ERR and set flag.
31:15	RSVD	<b>Reserved.</b>
14	EMASK14	<b>Data Comparator Error Mask 3.</b> Write 0 to enable EFLAG14 (bit 46) and to allow a Data Comparator 3 (DA_COMPARE_VAL_LO3/DA_COMPARE_VAL_HI3, GLIU0 MSR 100000DCh/100000DDh, GLIU1 MSR 400000DCh/400000DDh) event to generate an ERR and set flag.
13	EMASK13	<b>Data Comparator Error Mask 2.</b> Write 0 to enable EFLAG13 (bit 45) and to allow a Data Comparator 2 (DA_COMPARE_VAL_LO2/DA_COMPARE_VAL_HI2, GLIU0 MSR 100000D8h/100000D9h, GLIU1 MSR 400000D8h/400000D9h) event to generate an ERR and set flag.
12	EMASK12	<b>Data Comparator Error Mask 1.</b> Write 0 to enable EFLAG12 (bit 44) and to allow a Data Comparator 1 (DA_COMPARE_VAL_LO1/DA_COMPARE_VAL_HI1, GLIU0 MSR 100000D4h/100000D5h, GLIU1 MSR 400000D4h/400000D5h) event to generate an ERR and set flag.
11	EMASK11	<b>Data Comparator Error Mask 0.</b> Write 0 to enable EFLAG11 (bit 43) and to allow a Data Comparator 0 (DA_COMPARE_VAL_LO0/DA_COMPARE_VAL_HI0, GLIU0 MSR 100000D4h/100000D5h, GLIU1 MSR 400000D4h/400000D5h) event to generate an ERR and set flag.
10	EMASK10	<b>Request Comparator Error Mask 3.</b> Write 0 to enable EFLAG10 (bit 42) and to allow a Request Comparator 3 (RQ_COMPARE_VAL3, GLIU0 MSR 100000C6h, GLIU1 MSR 400000C6h) event to generate an ERR
9	EMASK9	<b>Request Comparator Error Mask 2.</b> Write 0 to enable EFLAG9 (bit 41) and to allow a Request Comparator 2 (RQ_COMPARE_VAL2, GLIU0 MSR 100000C4h, GLIU1 MSR 400000C4h) event to generate an ERR.

**GLD\_MSR\_ERROR Bit Descriptions (Continued)**

Bit	Name	Description
8	EMASK8	<b>Request Comparator Error Mask 1.</b> Write 0 to enable EFLAG8 (bit 40) and to allow a Request Comparator 1 (RQ_COMPARE_VAL1, GLIU0 MSR 100000C2h, GLIU1 MSR 400000C2h) event to generate an ERR
7	EMASK7	<b>Request Comparator Error Mask 0.</b> Write 0 to enable EFLAG7 (bit 39) and to allow a Request Comparator 0 (RQ_COMPARE_VAL0, GLIU0 MSR 100000C0h, GLIU1 MSR 400000C0h) event to generate an ERR
6	EMASK6	<b>Statistic Counter Error Mask 3.</b> Write 0 to enable EFLAG6 (bit 38) and to allow a Statistic Counter 3 (GLIU0 MSR 100000ACh, GLIU1 MSR 400000ACh) event to generate an ERR.
5	EMASK5	<b>Statistic Counter Error Mask 2.</b> Write 0 to enable EFLAG5 (bit 37) and to allow a Statistic Counter 2 (GLIU0 MSR 100000A8h, GLIU1 MSR 400000A8h) event to generate an ERR.
4	EMASK4	<b>Statistic Counter Error Mask 1.</b> Write 0 to enable EFLAG4 (bit 36) and to allow a Statistic Counter 1 (GLIU0 MSR 100000A4h, GLIU1 MSR 400000A4h) event to generate an ERR.
3	EMASK3	<b>Statistic Counter Error Mask 0.</b> Write 0 to enable EFLAG3 (bit 35) and to allow a Statistic Counter 0 (GLIU0 MSR 100000A0h, GLIU1 MSR 400000A0h) event to generate an ERR.
2	EMASK2	<b>Unhandled SMI Error Mask 2.</b> Write 0 to enable EFLAG2 (bit 34) and to allow the unhandled SSMI (synchronous error) event to generate an ERR.
1	EMASK1	<b>Unexpected Address Error Mask 1.</b> as Write 0 to enable EFLAG1 (bit 33) and to allow the unexpected address (synchronous error) event to generate an ERR.
0	EMASK0	<b>Unexpected Type Error Mask 0.</b> Write 0 to enable EFLAG0 (bit 32) and to allow the unexpected type (synchronous error) event to generate an ERR.

**4.2.1.5 GLD Power Management MSR (GLD\_MSR\_PM)**

MSR Address      GLIU0: 10002004h  
                     GLIU1: 40002004h  
 Type              R/W  
 Reset Value     00000000\_00000000h

**GLD\_MSR\_PM Register Map**

63	62	61	60	59	58	57	56	55	54	53	52	51	50	49	48	47	46	45	44	43	42	41	40	39	38	37	36	35	34	33	32
RSVD																															
31	30	29	28	27	26	25	24	23	22	21	20	19	18	17	16	15	14	13	12	11	10	9	8	7	6	5	4	3	2	1	0
RSVD																														PMODE_1	PMODE_0

## GLD\_MSR\_PM Bit Descriptions

Bit	Name	Description
63:4	RSVD	<b>Reserved.</b>
3:2	PMODE_1	<b>Power Mode 1.</b> Statistics and Time Slice Counters. 00: Disable clock gating. Clocks are always on. 01: Enable hardware clock gating. Clock goes off whenever this module's circuits are not busy. 10, 11: Reserved.
1:0	PMODE_0	<b>Power Mode 0.</b> Online GLIU logic. 00: Disable clock gating. Clocks are always on. 01: Enable hardware clock gating. Clock goes off whenever this module's circuits are not busy. 10, 11: Reserved.

## 4.2.1.6 GLD Diagnostic MSR (GLD\_MSR\_DIAG)

MSR Address	GLIU0: 10002005h GLIU1: 40002005h
Type	R/W
Reset Value	00000000_00000000h

This register is reserved for internal use by AMD and should not be written to.

## 4.2.2 GLIU Specific Registers

## 4.2.2.1 Coherency (COH)

MSR Address	GLIU0: 10000080h GLIU1: 40000080h
Type	R/W
Reset Value	Configuration Dependent

## COH Register Map

63	62	61	60	59	58	57	56	55	54	53	52	51	50	49	48	47	46	45	44	43	42	41	40	39	38	37	36	35	34	33	32
RSVD																															
31	30	29	28	27	26	25	24	23	22	21	20	19	18	17	16	15	14	13	12	11	10	9	8	7	6	5	4	3	2	1	0
RSVD																														COHP	

## COH Bit Descriptions

Bit	Name	Description
63:3	RSVD	<b>Reserved.</b>
2:0	COHP	<b>Coherent Device Port.</b> The port that coherents snoops are routed to. If the coherent device is on the other side of a bridge, the COHP points to the bridge.

**4.2.2.2 Port Active Enable (PAE)**

MSR Address	GLIU0: 10000081h GLIU1: 40000081h
Type	R/W
Reset Value	Boot Strap Dependent

Ports that are not implemented return 00 (RSVD). Ports that are slave only return 11. Master/Slave ports return the values as stated.

GLIU0 will reset all PAE to 11 (ON) except that GLIU0 PAE3 resets to 00 when the debug stall bootstrap is active (CPU port resets inactive for debug stall).

**PAE Register Map**

63	62	61	60	59	58	57	56	55	54	53	52	51	50	49	48	47	46	45	44	43	42	41	40	39	38	37	36	35	34	33	32
RSVD																															
31	30	29	28	27	26	25	24	23	22	21	20	19	18	17	16	15	14	13	12	11	10	9	8	7	6	5	4	3	2	1	0
RSVD																PAE0	PAE7	PAE6	PAE5	PAE4	PAE3	PAE2	PAE1								

**PAE Bit Descriptions**

Bit	Name	Description
63:16	RSVD	<b>Reserved.</b>
15:14	PAE0	<b>Port Active Enable for Port 0.</b> (GLIU0 = GLIU; GLIU1 = GLIU.) 00: OFF - Master transactions are disabled. 01: LOW - Master transactions limited to 1 outstanding transaction. 10: Reserved. 11: ON - Master transactions enabled with no limitations.
13:12	PAE7	<b>Port Active Enable for Port 7.</b> (GLIU0 = Not Used; GLIU1 = Not Used.) See bits [15:14] for decode.
11:10	PAE6	<b>Port Active Enable for Port 6.</b> (GLIU0 = Not Used; GLIU1 = SB.) See bits [15:14] for decode.
9:8	PAE5	<b>Port Active Enable for Port 5.</b> (GLIU0 = GP; GLIU1 = VIP.) See bits [15:14] for decode.
7:6	PAE4	<b>Port Active Enable for Port 4.</b> (GLIU0 = DC; GLIU1 = GLPCI.) See bits [15:14] for decode.
5:4	PAE3	<b>Port Active Enable for Port 3.</b> (GLIU0 = CPU Core; GLIU1 = GLCP.) See bits [15:14] for decode.
3:2	PAE2	<b>Port Active Enable for Port 2.</b> (GLIU0 = Interface to GLIU1; GLIU1 = VP.) See bits [15:14] for decode.
1:0	PAE1	<b>Port Active Enable for Port 1.</b> (GLIU0 = GLMC; GLIU1 = Interface to GLIU0.) See bits [15:14] for decode.

**4.2.2.3 Arbitration (ARB)**

MSR Address GLIU0: 10000082h  
 GLIU1: 40000082h  
 Type R/W  
 Reset Value 10000000\_00000000h

**ARB Register Map**

63	62	61	60	59	58	57	56	55	54	53	52	51	50	49	48	47	46	45	44	43	42	41	40	39	38	37	36	35	34	33	32
QUACK_EN	PIPE_DIS	RSVD	DACK_EN	RSVD																											
31	30	29	28	27	26	25	24	23	22	21	20	19	18	17	16	15	14	13	12	11	10	9	8	7	6	5	4	3	2	1	0
RSVD																															

**ARB Bit Descriptions**

Bit	Name	Description
63	QUACK_EN	<b>Quadruple Acknowledge Enabled.</b> Allow four acknowledgements in a row before advancing round-robin arbitration. Only applies when arbitrating matching priorities. 0: Disable. 1: Enable.
62	PIPE_DIS	<b>Pipelined Arbitration Disabled.</b> 0: Pipelined arbitration enabled and GLIU is not limited to one outstanding transaction. 1: Limit the entire GLIU to one outstanding transaction.
61	RSVD	<b>Reserved.</b>
60	DACK_EN	<b>Double Acknowledge Enabled.</b> Allow two acknowledgements in a row before advancing round-robin arbitration. Only applies when arbitrating matching priorities. 0: Disable. 1: Enable.
59:0	RSVD	<b>Reserved.</b>

**4.2.2.4 Asynchronous SMI (ASMI)**

MSR Address GLIU0: 10000083h  
 GLIU1: 40000083h  
 Type R/W  
 Reset Value 00000000\_00000000h

ASMI is a condensed version of the port ASMI signals. The MASK bits can be used to prevent a device from issuing an ASMI. If the MASK = 1, the device’s ASMI is disabled.

**ASMI Register Map**

63	62	61	60	59	58	57	56	55	54	53	52	51	50	49	48	47	46	45	44	43	42	41	40	39	38	37	36	35	34	33	32
RSVD																															
31	30	29	28	27	26	25	24	23	22	21	20	19	18	17	16	15	14	13	12	11	10	9	8	7	6	5	4	3	2	1	0
RSVD																ASMI_MASK7	ASMI_MASK6	ASMI_MASK5	ASMI_MASK4	ASMI_MASK3	ASMI_MASK2	ASMI_MASK1	ASMI_MASK0	ASMI_FLAG7	ASMI_FLAG6	ASMI_FLAG5	ASMI_FLAG4	ASMI_FLAG3	ASMI_FLAG2	ASMI_FLAG1	ASMI_FLAG0

## ASMI Bit Descriptions

Bit	Name	Description
63:16	RSVD	<b>Reserved.</b>
15	ASMI_MASK7	<b>Asynchronous SMI Mask for Port 7.</b> (GLIU0 = Not Used; GLIU1 = Not Used.) Write 0 to allow Port 7 to generate an ASMI. ASMI status is reported in bit 7.
14	ASMI_MASK6	<b>Asynchronous SMI Mask for Port 6.</b> (GLIU0 = Not Used; GLIU1 = SB.) Write 0 to allow Port 6 to generate an ASMI. ASMI status is reported in bit 6.
13	ASMI_MASK5	<b>Asynchronous SMI Mask for Port 5.</b> (GLIU0 = GP; GLIU1 = VIP.) Write 0 to allow Port 5 to generate an ASMI. ASMI status is reported in bit 5.
12	ASMI_MASK4	<b>Asynchronous SMI Mask for Port 4.</b> (GLIU0 = DC; GLIU1 = GLPCI.) Write 0 to allow Port 4 to generate an ASMI. ASMI status is reported in bit 4.
11	ASMI_MASK3	<b>Asynchronous SMI Mask for Port 3.</b> (GLIU0 = CPU Core; GLIU1 = GLCP.) Write 0 to allow Port 3 to generate an ASMI. ASMI status is reported in bit 3.
10	ASMI_MASK2	<b>Asynchronous SMI Mask for Port 2.</b> (GLIU0 = Interface to GLIU1; GLIU1 = VP.) Write 0 to allow Port 2 to generate an ASMI. ASMI status is reported in bit 2.
9	ASMI_MASK1	<b>Asynchronous SMI Mask for Port 1.</b> (GLIU0 = GLMC; GLIU1 = Interface to GLIU0.) Write 0 to allow Port 1 to generate an ASMI. ASMI status is reported in bit 1.
8	ASMI_MASK0	<b>Asynchronous SMI Mask for Port 0.</b> (GLIU0 = GLIU; GLIU1 = GLIU.) Write 0 to allow Port 0 to generate an ASMI. ASMI status is reported in bit 0.
7	ASMI_FLAG7 (RO)	<b>Asynchronous SMI Flag for Port 7 (Read Only).</b> (GLIU0 = Not Used; GLIU1 = Not Used.) If 1, this bit indicates that an ASMI was generated by Port 7. Cleared by source.
6	ASMI_FLAG6 (RO)	<b>Asynchronous SMI Flag for Port 6 (Read Only).</b> (GLIU0 = Not Used; GLIU1 = SB.) If 1, this bit indicates that an ASMI was generated by Port 6. Cleared by source.
5	ASMI_FLAG5 (RO)	<b>Asynchronous SMI Flag for Port 5 (Read Only).</b> (GLIU0 = GP; GLIU1 = VIP.) If 1, this bit indicates that an ASMI was generated by Port 5. Cleared by source.
4	ASMI_FLAG4 (RO)	<b>Asynchronous SMI Flag for Port 4 (Read Only).</b> (GLIU0 = DC; GLIU1 = GLPCI.) If 1, this bit indicates that an ASMI was generated by Port 4. Cleared by source.
3	ASMI_FLAG3 (RO)	<b>Asynchronous SMI Flag for Port 3 (Read Only).</b> (GLIU0 = CPU Core; GLIU1 = GLCP.) If 1, this bit indicates that an ASMI was generated by Port 37. Cleared by source.
2	ASMI_FLAG2 (RO)	<b>Asynchronous SMI Flag for Port 2 (Read Only).</b> (GLIU0 = Interface to GLIU1; GLIU1 = VP.) If 1, this bit indicates that an ASMI was generated by Port 2. Cleared by source.
1	ASMI_FLAG1 (RO)	<b>Asynchronous SMI Flag for Port 1 (Read Only).</b> (GLIU0 = GLMC; GLIU1 = Interface to GLIU0.) If 1, this bit indicates that an ASMI was generated by Port 1. Cleared by source.
0	ASMI_FLAG0 (RO)	<b>Asynchronous SMI Flag for Port 0 (Read Only).</b> (GLIU0 = GLIU; GLIU1 = GLIU.) If 1, this bit indicates that an ASMI was generated by Port 0. Cleared by source.

## 4.2.2.5 Asynchronous ERR (AERR)

MSR Address      GLIU0: 10000084h  
                       GLIU1: 40000084h  
 Type                R/W  
 Reset Value        00000000\_00000000h

AERR is a condensed version of the port ERR signals. The MASK bits can be used to prevent a device from issuing an AERR. If the MASK = 1, the device's AERR is disabled.

## AERR Register Map

63	62	61	60	59	58	57	56	55	54	53	52	51	50	49	48	47	46	45	44	43	42	41	40	39	38	37	36	35	34	33	32
RSVD																															
31	30	29	28	27	26	25	24	23	22	21	20	19	18	17	16	15	14	13	12	11	10	9	8	7	6	5	4	3	2	1	0
RSVD																AERR_MASK7	AERR_MASK6	AERR_MASK5	AERR_MASK4	AERR_MASK3	AERR_MASK2	AERR_MASK1	AERR_MASK0	AERR7	AERR6	AERR5	AERR4	AERR3	AERR2	AERR1	AERR0

## AERR Bit Descriptions

Bit	Name	Description
63:16	RSVD	<b>Reserved.</b>
15	AERR_MASK7	<b>Asynchronous Error Mask for Port 7.</b> (GLIU0 = Not Used; GLIU1 = Not Used.) Write 0 to allow Port 7 to generate an AERR. AERR status is reported in bit 7.
14	AERR_MASK6	<b>Asynchronous Error Mask for Port 6.</b> (GLIU0 = Not Used; GLIU1 = SB.) Write 0 to allow Port 6 to generate an AERR. AERR status is reported in bit 6.
13	AERR_MASK5	<b>Asynchronous Error Mask for Port 5.</b> (GLIU0 = GP; GLIU1 = VIP.) Write 0 to allow Port 5 to generate an AERR. AERR status is reported in bit 5.
12	AERR_MASK4	<b>Asynchronous Error Mask for Port 4.</b> (GLIU0 = DC; GLIU1 = GLPCI.) Write 0 to allow Port 4 to generate an AERR. AERR status is reported in bit 4.
11	AERR_MASK3	<b>Asynchronous Error Mask for Port 3.</b> (GLIU0 = CPU Core; GLIU1 = GLCP.) Write 0 to allow Port 3 to generate an AERR. AERR status is reported in bit 3.
10	AERR_MASK2	<b>Asynchronous Error Mask for Port 2.</b> (GLIU0 = Interface to GLIU1; GLIU1 = VP.) Write 0 to allow Port 2 to generate an AERR. AERR status is reported in bit 2.
9	AERR_MASK1	<b>Asynchronous Error Mask for Port 1.</b> (GLIU0 = GLMC; GLIU1 = Interface to GLIU0.) Write 0 to allow Port 1 to generate an AERR. AERR status is reported in bit 1.
8	AERR_MASK0	<b>Asynchronous Error Mask for Port 0.</b> (GLIU0 = GLIU; GLIU1 = GLIU.) Write 0 to allow Port 0 to generate an AERR. AERR status is reported in bit 0.
7	AERR_FLAG7 (RO)	<b>Asynchronous Error for Port 7 (Read Only).</b> (GLIU0 = Not Used; GLIU1 = Not Used.) If 1, indicates that an AERR was generated by Port 7. Cleared by source.
6	AERR_FLAG6 (RO)	<b>Asynchronous Error for Port 6 (Read Only).</b> (GLIU0 = Not Used; GLIU1 = SB.) If 1, indicates that an AERR was generated by Port 6. Cleared by source.
5	AERR_FLAG5 (RO)	<b>Asynchronous Error for Port 5 (Read Only).</b> (GLIU0 = GP; GLIU1 = VIP.) If 1, indicates that an AERR was generated by Port 5. Cleared by source.
4	AERR_FLAG4 (RO)	<b>Asynchronous Error for Port 4 (Read Only).</b> (GLIU0 = DC; GLIU1 = GLPCI.) If 1, indicates that an AERR was generated by Port 4. Cleared by source.
3	AERR_FLAG3 (RO)	<b>Asynchronous Error for Port 3 (Read Only).</b> (GLIU0 = CPU Core; GLIU1 = GLCP.) If 1, indicates that an AERR was generated by Port 3. Cleared by source.
2	AERR_FLAG2 (RO)	<b>Asynchronous Error for Port 2 (Read Only).</b> (GLIU0 = Interface to GLIU1; GLIU1 = VP.) If 1, indicates that an AERR was generated by Port 2. Cleared by source.
1	AERR_FLAG1 (RO)	<b>Asynchronous Error for Port 1 (Read Only).</b> (GLIU0 = GLMC; GLIU1 = Interface to GLIU0.) If 1, indicates that an AERR was generated by Port 1. Cleared by source.
0	AERR_FLAG0 (RO)	<b>Asynchronous Error for Port 0 (Read Only).</b> (GLIU0 = GLIU; GLIU1 = GLIU.) If 1, indicates that an AERR was generated by Port 0. Cleared by source.



**4.2.2.6 GLIU Physical Capabilities (PHY\_CAP)**

MSR Address      GLIU0: 10000086h  
                       GLIU1: 40000086h  
 Type                R/W  
 Reset Value      GLIU0: 20291830\_010C1086h  
                       GLIU1: 20311030\_0100400Ah

**PHY\_CAP Register Map**

63	62	61	60	59	58	57	56	55	54	53	52	51	50	49	48	47	46	45	44	43	42	41	40	39	38	37	36	35	34	33	32
RSVD	NSTAT_CNT	NDBG_DA_CMP	NDBG_RQ_CMP	NPORTS				NCOH				NIOD_SC				NIOD_BM				NP2D_BMK											
				NP2D_SC				NP2D_RO				NP2D_R				NP2D_BMO				NP2D_BM											
31	30	29	28	27	26	25	24	23	22	21	20	19	18	17	16	15	14	13	12	11	10	9	8	7	6	5	4	3	2	1	0
NP2D_BMK	NP2D_SC				NP2D_RO				NP2D_R				NP2D_BMO				NP2D_BM														

**PHY\_CAP Bit Descriptions**

Bit	Name	Description
63	RSVD	Reserved.
62:60	NSTAT_CNT	Number Of Statistic Counters.
59:57	NDBG_DA_CMP	Number Of Data Comparators.
56:54	NDBG_RQ_CMP	Number Of Request Comparators.
53:51	NPORTS	Number of Ports on the GLIU.
50:48	NCOH	Number of Coherent Devices.
47:42	NIOD_SC	Number of IOD_SC Descriptors.
41:36	NIOD_BM	Number of IOD_BM Descriptors.
35:30	NP2D_BMK	Number of P2D_BMK Descriptors.
29:24	NP2D_SC	Number of P2D_SC Descriptors.
23:18	NP2D_RO	Number of P2D_RO Descriptors.
17:12	NP2D_R	Number of P2D_R Descriptors.
11:6	NP2D_BMO	Number of P2D_BMO Descriptors.
5:0	NP2D_BM	Number of P2D_BM Descriptors.

**4.2.2.7 N Outstanding Response (NOUT\_RESP)**

MSR Address    GLIU0: 10000087h  
                   GLIU1: 40000087h  
 Type            RO  
 Reset Value    00000000\_00000000h

**NOUT\_RESP Register Map**

63	62	61	60	59	58	57	56	55	54	53	52	51	50	49	48	47	46	45	44	43	42	41	40	39	38	37	36	35	34	33	32
NOUT_RESP7								NOUT_RESP6								NOUT_RESP5								NOUT_RESP4							
31	30	29	28	27	26	25	24	23	22	21	20	19	18	17	16	15	14	13	12	11	10	9	8	7	6	5	4	3	2	1	0
NOUT_RESP3								NOUT_RESP2								NOUT_RESP1								NOUT_RESP0							

**NOUT\_RESP Bit Descriptions**

Bit	Name	Description
63:56	NOOUT_RESP7	<b>Number of Outstanding Responses on Port 7.</b> (GLIU0 = Not Used; GLIU1 = Not Used.)
55:48	NOOUT_RESP6	<b>Number of Outstanding Responses on Port 6.</b> (GLIU0 = Not Used; GLIU1 = SB.)
47:40	NOOUT_RESP5	<b>Number of Outstanding Responses on Port 5.</b> (GLIU0 = GP; GLIU1 = VIP.)
39:32	NOOUT_RESP4	<b>Number of Outstanding Responses on Port 4.</b> (GLIU0 = DC; GLIU1 = GLPCI.)
31:24	NOOUT_RESP3	<b>Number of Outstanding Responses on Port 3.</b> (GLIU0 = CPU Core; GLIU1 = GLCP.)
23:16	NOOUT_RESP2	<b>Number of Outstanding Responses on Port 2.</b> (GLIU0 = Interface to GLIU1; GLIU1 = VP.)
15:8	NOOUT_RESP1	<b>Number of Outstanding Responses on Port 1.</b> (GLIU0 = GLMC; GLIU1 = Interface to GLIU0.)
7:0	NOOUT_RESP0	<b>Number of Outstanding Responses on Port 0.</b> (GLIU0 = GLIU; GLIU1 = GLIU.)

**4.2.2.8 N Outstanding Write Data (NOUT\_WDATA)**

MSR Address    GLIU0: 10000088h  
                   GLIU1: 40000088h  
 Type            RO  
 Reset Value    00000000\_00000000h

**NOUT\_WDATA Register Map**

63	62	61	60	59	58	57	56	55	54	53	52	51	50	49	48	47	46	45	44	43	42	41	40	39	38	37	36	35	34	33	32
NOUT_WDATA7								NOUT_WDATA6								NOUT_WDATA5								NOUT_WDATA4							
31	30	29	28	27	26	25	24	23	22	21	20	19	18	17	16	15	14	13	12	11	10	9	8	7	6	5	4	3	2	1	0
NOUT_WDATA3								NOUT_WDATA2								NOUT_WDATA1								NOUT_WDATA0							

**NOUT\_WDATA Bit Descriptions**

Bit	Name	Description
63:56	NOOUT_WDATA7	<b>Number of Outstanding Write Data on Port 7.</b> (GLIU0 = Not Used; GLIU1 = Not Used.)
55:48	NOOUT_WDATA6	<b>Number of Outstanding Write Data on Port 6.</b> (GLIU0 = Not Used; GLIU1 = SB.)
47:40	NOOUT_WDATA5	<b>Number of Outstanding Write Data on Port 5.</b> (GLIU0 = GP; GLIU1 = VIP.)
39:32	NOOUT_WDATA4	<b>Number of Outstanding Write Data on Port 4.</b> (GLIU0 = DC; GLIU1 = GLPCI.)
31:24	NOOUT_WDATA3	<b>Number of Outstanding Write Data on Port 3.</b> (GLIU0 = CPU Core; GLIU1 = GLCP.)
23:16	NOOUT_WDATA2	<b>Number of Outstanding Write Data on Port 2.</b> (GLIU0 = Interface to GLIU1; GLIU1 = VP.)
15:8	NOOUT_WDATA1	<b>Number of Outstanding Write Data on Port 1.</b> (GLIU0 = GLMC; GLIU1 = Interface to GLIU0.)
7:0	NOOUT_WDATA0	<b>Number of Outstanding Write Data on Port 0.</b> (GLIU0 = GLIU; GLIU1 = GLIU.)

**4.2.2.9 SLAVE\_ONLY**

MSR Address    GLIU0: 10000089h  
                   GLIU1: 40000089h  
 Type            RO  
 Reset Value    GLIU0: 00000000\_00000010h  
                   GLIU1: 00000000\_00000100h

**SLAVE\_ONLY Register Map**

63	62	61	60	59	58	57	56	55	54	53	52	51	50	49	48	47	46	45	44	43	42	41	40	39	38	37	36	35	34	33	32
RSVD																															
31	30	29	28	27	26	25	24	23	22	21	20	19	18	17	16	15	14	13	12	11	10	9	8	7	6	5	4	3	2	1	0
RSVD																							SLAVE_ONLY								

**SLAVE\_ONLY Bit Descriptions**

Bit	Name	Description
63:8	RSVD	<b>Reserved.</b>
7	P7_SLAVE_ONLY	<b>Port 7 Slave Only.</b> (GLIU0 = Not Used; GLIU1 = Not Used.) If high, indicates that Port 7 is a slave port. If low, Port 7 is a master/slave port.

**SLAVE\_ONLY Bit Descriptions (Continued)**

Bit	Name	Description
6	P6_SLAVE_ONLY	<b>Port 6 Slave Only.</b> (GLIU0 = Not Used; GLIU1 = SB.) If high, indicates that Port 6 is a slave port. If low, Port 6 is a master/slave port.
5	P5_SLAVE_ONLY	<b>Port 5 Slave Only.</b> (GLIU0 = GP; GLIU1 = VIP.) If high, indicates that Port 5 is a slave port. If low, Port 5 is a master/slave port.
4	P4_SLAVE_ONLY	<b>Port 4 Slave Only.</b> (GLIU0 = DC; GLIU1 = GLPCI.) If high, indicates that Port 4 is a slave port. If low, Port 4 is a master/slave port.
3	P3_SLAVE_ONLY	<b>Port 3 Slave Only.</b> (GLIU0 = CPU Core; GLIU1 = GLCP.) If high, indicates that Port 3 is a slave port. If low, Port 3 is a master/slave port.
2	P2_SLAVE_ONLY	<b>Port 2 Slave Only.</b> (GLIU0 = Interface to GLIU1; GLIU1 = VP.) If high, indicates that Port 2 is a slave port. If low, Port 2 is a master/slave port.
1	P1_SLAVE_ONLY	<b>Port 1 Slave Only.</b> (GLIU0 = GLMC; GLIU1 = Interface to GLIU0.) If high, indicates that Port 1 is a slave port. If low, Port 1 is a master/slave port.
0	P0_SLAVE_ONLY	<b>Port 0 Slave Only.</b> (GLIU0 = GLIU; GLIU1 = GLIU.) If high, indicates that Port 0 is a slave port. If low, Port 0 is a master/slave port.

**4.2.2.10 WHO AM I (WHOAMI)**

MSR Address	GLIU0: 1000008Bh GLIU1: 4000008Bh
Type	RO
Reset Value	Configuration Dependent

**WHO AM I Register Map**

63	62	61	60	59	58	57	56	55	54	53	52	51	50	49	48	47	46	45	44	43	42	41	40	39	38	37	36	35	34	33	32
RSVD																															
31	30	29	28	27	26	25	24	23	22	21	20	19	18	17	16	15	14	13	12	11	10	9	8	7	6	5	4	3	2	1	0
RSVD																														DSID	

**WHO AM I Bit Descriptions**

Bit	Name	Description
63:3	RSVD	<b>Reserved.</b>
2:0	DSID	<b>Source ID of the Initiating Device.</b> Used to prevent self referencing transactions. 000: Port 0 (GLIU0 = GLIU; GLIU1 = GLIU.) 001: Port 1 (GLIU0 = GLMC; GLIU1 = Interface to GLIU0.) 010: Port 2 (GLIU0 = Interface to GLIU1; GLIU1 = VP.) 011: Port 3 (GLIU0 = CPU Core; GLIU1 = GLCP.) 100: Port 4 (GLIU0 = DC; GLIU1 = GLPCI.) 101: Port 5 (GLIU0 = GP; GLIU1 = VIP.) 110: Port 6 (GLIU0 = Not Used; GLIU1 = SB.) 111: Port 7 (GLIU0 = Not Used; GLIU1 = Not Used.)

**4.2.2.11 GLIU Slave Disable (GLIU\_SLV)**

MSR Address    GLIU0: 1000008Ch  
                   GLIU1: 4000008Ch  
 Type            R/W  
 Reset Value    00000000\_00000000h

The slave disable registers are available for the number of ports on the GLIU. The unused ports return 0.

**GLIU\_SLV Register Map**

63	62	61	60	59	58	57	56	55	54	53	52	51	50	49	48	47	46	45	44	43	42	41	40	39	38	37	36	35	34	33	32
RSVD																															
31	30	29	28	27	26	25	24	23	22	21	20	19	18	17	16	15	14	13	12	11	10	9	8	7	6	5	4	3	2	1	0
RSVD																								SLAVE_DIS7	SLAVE_DIS6	SLAVE_DIS5	SLAVE_DIS4	SLAVE_DIS3	SLAVE_DIS2	SLAVE_DIS1	SLAVE_DIS0

**GLIU\_SLV Bit Descriptions**

Bit	Name	Description
63:8	RSVD	<b>Reserved.</b>
7	SLAVE_DIS7	<b>Slave Transactions Disable for Port 7.</b> (GLIU0 = Not Used; GLIU1 = Not Used.) Write 1 to disable slave transactions to Port 7.
6	SLAVE_DIS6	<b>Slave Transactions Disable for Port 6.</b> (GLIU0 = Not Used; GLIU1 = SB.) Write 1 to disable slave transactions to Port 6.
5	SLAVE_DIS5	<b>Slave Transactions Disable for Port 5.</b> (GLIU0 = GP; GLIU1 = VIP.) Write 1 to disable slave transactions to Port 5.
4	SLAVE_DIS4	<b>Slave Transactions Disable for Port 4.</b> (GLIU0 = DC; GLIU1 = GLPCI.) Write 1 to disable slave transactions to Port 4.
3	SLAVE_DIS3	<b>Slave Transactions Disable for Port 3.</b> (GLIU0 = CPU Core; GLIU1 = GLCP.) Write 1 to disable slave transactions to Port 3.
2	SLAVE_DIS2	<b>Slave Transactions Disable for Port 2.</b> (GLIU0 = Interface to GLIU1; GLIU1 = VP.) Write 1 to disable slave transactions to Port 2.
1	SLAVE_DIS1	<b>Slave Transactions Disable for Port 1.</b> (GLIU0 = GLMC; GLIU1 = Interface to GLIU0.) Write 1 to disable slave transactions to Port 1.
0	SLAVE_DIS0	<b>Slave Transactions Disable for Port 0.</b> (GLIU0 = GLIU; GLIU1 = GLIU.) Write 1 to disable slave transactions to Port 0.

**4.2.2.12 Arbitration2 (ARB2)**

MSR Address    GLIU0: 1000008Dh  
                   GLIU1: 4000008Dh  
 Type            R/W  
 Reset Value    00000000\_00000000h

**ARB2 Register Map**

63	62	61	60	59	58	57	56	55	54	53	52	51	50	49	48	47	46	45	44	43	42	41	40	39	38	37	36	35	34	33	32
RSVD																															
31	30	29	28	27	26	25	24	23	22	21	20	19	18	17	16	15	14	13	12	11	10	9	8	7	6	5	4	3	2	1	0
RSVD																													THROT_EN	THRESH	

**ARB2 Bit Descriptions**

Bit	Name	Description
63:4	RSVD	<b>Reserved.</b>
3	THROT_EN	<b>Arbitration Throttling Enable.</b> When set, arbitration is prevented in this GLIU if the other GLIU is retreating a priority above the THRESH priority.
2:0	THRESH	<b>Priority Threshold.</b> See THROT_EN description. Priority threshold value must be 4 or less.  0: Disable. 1: Enable.

### 4.2.3 GLIU Statistic and Comparator MSRs

#### 4.2.3.1 Descriptor Statistic Counter (STATISTIC\_CNT[0:3])

##### Descriptor Statistic Counter (STATISTIC\_CNT[0])

MSR Address GLIU0: 100000A0h  
 GLIU1: 400000A0h  
 Type R/W  
 Reset Value 00000000\_00000000h

##### Descriptor Statistic Counter (STATISTIC\_CNT[2])

MSR Address GLIU0: 100000A8h  
 GLIU1: 400000A8h  
 Type R/W  
 Reset Value 00000000\_00000000h

##### Descriptor Statistic Counter (STATISTIC\_CNT[1])

MSR Address GLIU0: 100000A4h  
 GLIU1: 400000A4h  
 Type R/W  
 Reset Value 00000000\_00000000h

##### Descriptor Statistic Counter (STATISTIC\_CNT[3])

MSR Address GLIU0: 100000ACh  
 GLIU1: 400000ACh  
 Type R/W  
 Reset Value 00000000\_00000000h

#### STATISTIC\_CNT[0:3] Registers Map

63	62	61	60	59	58	57	56	55	54	53	52	51	50	49	48	47	46	45	44	43	42	41	40	39	38	37	36	35	34	33	32
LOAD_VAL																															
31	30	29	28	27	26	25	24	23	22	21	20	19	18	17	16	15	14	13	12	11	10	9	8	7	6	5	4	3	2	1	0
CNT																															

#### STATISTIC\_CNT[0:3] Bit Descriptions

Bit	Name	Description
63:32	LOAD_VAL	<b>Counter Load Value.</b> The value loaded here is used as the initial Statistics Counter value when a LOAD action occurs or is commanded.
31:0	CNT	<b>Counter Value.</b> These bits provide the current counter value when read.

4.2.3.2 Statistic Mask (STATISTIC\_MASK[0:3])

**Descriptor Statistic Mask (STATISTIC\_MASK[0])**

MSR Address GLIU0: 100000A1h  
 GLIU1: 400000A1h  
 Type R/W  
 Reset Value 00000000\_00000000h

**Descriptor Statistic Mask (STATISTIC\_MASK[2])**

MSR Address GLIU0: 100000A9h  
 GLIU1: 400000A9h  
 Type R/W  
 Reset Value 00000000\_00000000h

**Descriptor Statistic Mask (STATISTIC\_MASK[1])**

MSR Address GLIU0: 100000A5h  
 GLIU1: 400000A5h  
 Type R/W  
 Reset Value 00000000\_00000000h

**Descriptor Statistic Mask (STATISTIC\_MASK[3])**

MSR Address GLIU0: 100000ADh  
 GLIU1: 400000ADh  
 Type R/W  
 Reset Value 00000000\_00000000h

**STATISTIC\_MASK[0:3] Register Map**

63	62	61	60	59	58	57	56	55	54	53	52	51	50	49	48	47	46	45	44	43	42	41	40	39	38	37	36	35	34	33	32
IOD_MASK																															
31	30	29	28	27	26	25	24	23	22	21	20	19	18	17	16	15	14	13	12	11	10	9	8	7	6	5	4	3	2	1	0
P2D MASK																															

**STATISTIC\_MASK[0:3] Bit Descriptions**

Bit	Name	Description
63:32	IOD_MASK	<b>Mask for Hits to Each IOD.</b> Hits are determined after the request is arbitrated. A hit is determined by the following logical equation: Hit =  (IOD_MASK[n-1:0] & RQ_DESC_HIT[n-1:0] && is_io)    (P2D_MASK[n-1:0] & RQ_DESC_HIT[n-1:0] && is_mem).
31:0	P2D_MASK	<b>Mask for Hits to Each P2D.</b> A hit is determined by the following logical equation: Hit =  (IOD_MASK[n-1:0] & RQ_DESC_HIT[n-1:0] && is_io)    (P2D_MASK[n-1:0] & RQ_DESC_HIT[n-1:0] && is_mem).



## 4.2.3.3 Statistic Action (STATISTIC\_ACTION[0:3])

**Descriptor Statistic Action (STATISTIC\_ACTION[0])**

MSR Address GLIU0: 100000A2h  
GLIU1: 400000A2h  
Type R/W  
Reset Value 00000000\_00000000h

**Descriptor Statistic Action (STATISTIC\_ACTION[2])**

MSR Address GLIU0: 100000AAh  
GLIU1: 400000AAh  
Type R/W  
Reset Value 00000000\_00000000h

**Descriptor Statistic Action (STATISTIC\_ACTION[1])**

MSR Address GLIU0: 100000A6h  
GLIU1: 400000A6h  
Type R/W  
Reset Value 00000000\_00000000h

**Descriptor Statistic Action (STATISTIC\_ACTION[3])**

MSR Address GLIU0: 100000AEh  
GLIU1: 400000AEh  
Type R/W  
Reset Value 00000000\_00000000h

**STATISTIC\_ACTION[0:3] Register Map**

63	62	61	60	59	58	57	56	55	54	53	52	51	50	49	48	47	46	45	44	43	42	41	40	39	38	37	36	35	34	33	32
RSVD																															
31	30	29	28	27	26	25	24	23	22	21	20	19	18	17	16	15	14	13	12	11	10	9	8	7	6	5	4	3	2	1	0
RSVD								PREDIV														WRAP	ZERO_AERR	ZXERO_ASMI	ALWAYS_DEC	HIT_AERR	HIT_ASMI	HIT_DEC	HIT_LDEN		

**STATISTIC\_ACTION[0:3] Bit Descriptions**

Bit	Name	Description
63:24	RSVD	<b>Reserved.</b>
23:8	PREDIV	<b>Pre Divider.</b> Used if ALWAYS_DEC (bit 4) is set. The predivider is free running and extends the depth of the counter.
7	WRAP	<b>Decrement Counter Beyond Zero and Wrap.</b> 0: Disable wrap; counter stops when it reaches zero. 1: Enable wrap; counter decrements through 0 to all ones.
6	ZERO_AERR	<b>Assert AERR on cnt = 0.</b> Assert AERR when STATISTIC_CNT[x] reaches 0. 0: Disable. 1: Enable.
5	ZERO_ASMI	<b>Assert ASMI on cnt = 0.</b> Assert ASMI when STATISTIC_CNT[x] reaches 0. 0: Disable. 1: Enable.
4	ALWAYS_DEC	<b>Always Decrement Counter.</b> If enabled, the counter decrements on every memory clock subject to the prescaler value PREDIV (bits [23:8]). Decrementing continues unless loading is occurring due to another action, or if the counter reaches zero and WRAP is disabled (bit 7). 0: Disable. 1: Enable
3	HIT_AERR	<b>Assert AERR on Descrptor Hit.</b> The descriptor hits are ANDed with the masks and then all ORed together. 0: Disable. 1: Enable

### STATISTIC\_ACTION[0:3] Bit Descriptions

Bit	Name	Description
2	HIT_ASMI	<b>Assert ASMI on Descriptor Hit.</b> The descriptor hits are ANDed with the masks and then all ORed together. 0: Disable. 1: Enable.
1	HIT_DEC	<b>Decrement Counter on Descriptor Hit.</b> The descriptor hits are ANDed with the masks and then all ORed together. 0: Disable. 1: Enable.
0	HIT_LDEN	<b>Load Counter on Descriptor Hit.</b> The descriptor hits are ANDed with the masks and then all ORed together. 0: Disable. 1: Enable.

#### 4.2.3.4 Request Compare Value (RQ\_COMPARE\_VAL[0:3])

The RQ Compare Value and the RQ Compare Mask enable traps on specific transactions. A hit to the RQ Compare is determined by  $hit = (RQ\_IN \& RQ\_COMPARE\_MASK) == RQ\_COMPARE\_VAL$ . A hit can trigger the RQ\_CMP error sources when they are enabled. The value is compared only after the packet is arbitrated.

##### Request Compare Value (RQ\_COMPARE\_VAL[0])

MSR Address GLIU0: 100000C0h  
GLIU1: 400000C0h  
Type R/W  
Reset Value 001FFFFFF\_FFFFFFFFh

##### Request Compare Value (RQ\_COMPARE\_VAL[2])

MSR Address GLIU0: 100000C4h  
GLIU1: 400000C4h  
Type R/W  
Reset Value 001FFFFFF\_FFFFFFFFh

##### Request Compare Value (RQ\_COMPARE\_VAL[1])

MSR Address GLIU0: 100000C2h  
GLIU1: 400000C2h  
Type R/W  
Reset Value 001FFFFFF\_FFFFFFFFh

##### Request Compare Value (RQ\_COMPARE\_VAL[3])

MSR Address GLIU0: 100000C6h  
GLIU1: 400000C6h  
Type R/W  
Reset Value 001FFFFFF\_FFFFFFFFh

### RQ\_COMPARE\_VAL[0:3] Register

63	62	61	60	59	58	57	56	55	54	53	52	51	50	49	48	47	46	45	44	43	42	41	40	39	38	37	36	35	34	33	32
RSVD											RQ_VAL																				
31	30	29	28	27	26	25	24	23	22	21	20	19	18	17	16	15	14	13	12	11	10	9	8	7	6	5	4	3	2	1	0
RQ_VAL																															

### RQ\_COMPARE\_VAL[0:3] Bit Descriptions

Bit	Name	Description
63:53	RSVD	<b>Reserved.</b>
52:0	RQ_VAL	<b>Request Packet Value.</b> This is the value compared against the logical bit-wise AND of the incoming request packet and the RQ_COMPMASK in order to determine a 'hit'.

**4.2.3.5 Request Compare Mask (RQ\_COMPARE\_MASK[0:3])**

The RQ Compare Value and the RQ Compare Mask enable traps on specific transactions. A hit to the RQ Compare is determined by  $hit = (RQ\_IN \& RQ\_COMPARE\_MASK) == RQ\_COMPARE\_VAL$ . A hit can trigger the RQ\_CMP error sources when they are enabled. The value is compared only after the packet is arbitrated.

**Request Compare Mask (RQ\_COMPARE\_MASK[0])**

MSR Address GLIU0: 100000C1h  
 GLIU1: 400000C1h  
 Type R/W  
 Reset Value 00000000\_00000000h

**Request Compare Mask (RQ\_COMPARE\_MASK[2])**

MSR Address GLIU0: 100000C5h  
 GLIU1: 400000C5h  
 Type R/W  
 Reset Value 00000000\_00000000h

**Request Compare Mask (RQ\_COMPARE\_MASK[1])**

MSR Address GLIU0: 100000C3h  
 GLIU1: 400000C3h  
 Type R/W  
 Reset Value 00000000\_00000000h

**Request Compare Mask (RQ\_COMPARE\_MASK[3])**

MSR Address GLIU0: 100000C7h  
 GLIU1: 400000C7h  
 Type R/W  
 Reset Value 00000000\_00000000h

**RQ\_COMPARE\_MASK[0:3] Register Map**

63	62	61	60	59	58	57	56	55	54	53	52	51	50	49	48	47	46	45	44	43	42	41	40	39	38	37	36	35	34	33	32
RSVD											RQ_MASK																				
31	30	29	28	27	26	25	24	23	22	21	20	19	18	17	16	15	14	13	12	11	10	9	8	7	6	5	4	3	2	1	0
RQ_MASK																															

**RQ\_COMPARE\_MASK[0:3] Bit Descriptions**

Bit	Name	Description
63:53	RSVD	<b>Reserved.</b>
52:0	RQ_MASK	<b>Request Packet Mask.</b> This field is bit-wise logically ANDed with the incoming request packet before it is compared to the RQ_COMPVAL.

**4.2.3.6 DA Compare Value Low (DA\_COMPARE\_VAL\_LO[0:3])**

The DA Compare Value and the DA Compare Mask enable traps on specific transactions. A hit to the DA Compare is determined by  $hit = (DA\_IN \& DA\_COMPARE\_MASK) == DA\_COMPARE\_VAL$ . A hit can trigger the DA\_CMP error sources when they are enabled. The value is compared only after the packet is arbitrated.

**Data Compare Value Low (DA\_COMPARE\_VAL\_LO[0])**

MSR Address GLIU0: 100000D0h  
 GLIU1: 400000D0h  
 Type R/W  
 Reset Value 00001FFF\_FFFFFFFFh

**Data Compare Value Low (DA\_COMPARE\_VAL\_LO[2])**

MSR Address GLIU0: 100000D8h  
 GLIU1: 400000D8h  
 Type R/W  
 Reset Value 00001FFF\_FFFFFFFFh

**Data Compare Value Low (DA\_COMPARE\_VAL\_LO[1])**

MSR Address GLIU0: 100000D4h  
 GLIU1: 400000D4h  
 Type R/W  
 Reset Value 00001FFF\_FFFFFFFFh

**Data Compare Value Low (DA\_COMPARE\_VAL\_LO[3])**

MSR Address GLIU0: 100000DCh  
 GLIU1: 400000DCh  
 Type R/W  
 Reset Value 00001FFF\_FFFFFFFFh

**DA\_COMPARE\_VAL\_LO[0:3] Register**

63	62	61	60	59	58	57	56	55	54	53	52	51	50	49	48	47	46	45	44	43	42	41	40	39	38	37	36	35	34	33	32
RSVD																		DALO_VAL													
31	30	29	28	27	26	25	24	23	22	21	20	19	18	17	16	15	14	13	12	11	10	9	8	7	6	5	4	3	2	1	0
DALO_VAL																															

**DA\_COMPARE\_VAL\_LO[0:3] Bit Descriptions**

Bit	Name	Description
63:45	RSVD	<b>Reserved.</b>
44:0	DALO_VAL	<b>DA Packet Compare Value [44:0].</b> This field forms the lower portion of the data value, which is compared to the logical bit-wise AND of the incoming data value and the data value compare mask in order to determine a 'hit'. The "HI" and "LO" portions of the incoming data, the compare value, and the compare mask, are assembled into complete bit patterns before these operations occur.

#### 4.2.3.7 DA Compare Value High (DA\_COMPARE\_VAL\_HI[0:3])

The DA Compare Value and the DA Compare Mask enable traps on specific transactions. A hit to the DA Compare is determined by  $\text{hit} = (\text{DA\_IN} \& \text{DA\_COMPARE\_MASK}) == \text{DA\_COMPARE\_VAL}$ . A hit can trigger the DA\_CMP error sources when they are enabled. The value is compared only after the packet is arbitrated.

##### Data Compare Value High (DA\_COMPARE\_VAL\_HI[0])

MSR Address GLIU0: 100000D1h  
GLIU1: 400000D1h  
Type R/W  
Reset Value 0000000F\_FFFFFFFFh

##### Data Compare Value High (DA\_COMPARE\_VAL\_HI[2])

MSR Address GLIU0: 100000D9h  
GLIU1: 400000D9h  
Type R/W  
Reset Value 0000000F\_FFFFFFFFh

##### Data Compare Value High (DA\_COMPARE\_VAL\_HI[1])

MSR Address GLIU0: 100000D5h  
GLIU1: 400000D5h  
Type R/W  
Reset Value 0000000F\_FFFFFFFFh

##### Data Compare Value High (DA\_COMPARE\_VAL\_HI[3])

MSR Address GLIU0: 100000DDh  
GLIU1: 400000DDh  
Type R/W  
Reset Value 0000000F\_FFFFFFFFh

#### DA\_COMPARE\_VAL\_HI[0:3] Register Map

63	62	61	60	59	58	57	56	55	54	53	52	51	50	49	48	47	46	45	44	43	42	41	40	39	38	37	36	35	34	33	32
RSVD																															
31	30	29	28	27	26	25	24	23	22	21	20	19	18	17	16	15	14	13	12	11	10	9	8	7	6	5	4	3	2	1	0
DAHI_VAL																															

#### DA\_COMPARE\_VAL\_HI[0:3] Bit Descriptions

Bit	Name	Description
63:36	RSVD	<b>Reserved.</b>
35:0	DAHI_VAL	<b>DA Packet Compare Value [80:45].</b> This field forms the upper portion of the data value which is compared to the logical bit-wise AND of the incoming data value AND the data value compare mask in order to determine a 'hit'. The "HI" and "LO" portions of the incoming data, the compare value, and the compare mask, are assembled into complete bit patterns before these operations occur.

4.2.3.8 DA Compare Mask Low (DA\_COMPARE\_MASK\_LO[0:3])

**Data Compare Mask Low (DA\_COMPARE\_MASK\_LO[0])**  
 MSR Address GLIU0: 100000D2h  
 GLIU1: 400000D2h  
 Type R/W  
 Reset Value 00000000\_00000000h

**Data Compare Mask Low (DA\_COMPARE\_MASK\_LO[2])**  
 MSR Address GLIU0: 100000DAh  
 GLIU1: 400000DAh  
 Type R/W  
 Reset Value 00000000\_00000000h

**Data Compare Mask Low (DA\_COMPARE\_MASK\_LO[1])**  
 MSR Address GLIU0: 100000D6h  
 GLIU1: 400000D6h  
 Type R/W  
 Reset Value 00000000\_00000000h

**Data Compare Mask Low (DA\_COMPARE\_MASK\_LO[3])**  
 MSR Address GLIU0: 100000DEh  
 GLIU1: 400000DEh  
 Type R/W  
 Reset Value 00000000\_00000000h

The DA Compare Value and the DA Compare Mask enable traps on specific transactions. A hit to the DA Compare is determined by  $hit = (DA\_IN \& DA\_COMPARE\_MASK) == DA\_COMPARE\_VAL$ . A hit can trigger the DA\_CMP error sources when they are enabled. The value is compared only after the packet is arbitrated.

DA\_COMPARE\_VAL\_HI[0:3] Register Map

63	62	61	60	59	58	57	56	55	54	53	52	51	50	49	48	47	46	45	44	43	42	41	40	39	38	37	36	35	34	33	32
RSVD																		DALO_MASK													
31	30	29	28	27	26	25	24	23	22	21	20	19	18	17	16	15	14	13	12	11	10	9	8	7	6	5	4	3	2	1	0
DALO_MASK																															

DA\_COMPARE\_MASK\_LO[0:3] Bit Descriptions

Bit	Name	Description
63:45	RSVD	Reserved.
44:0	DALO_MASK	<b>DA Packet Compare Value [44:0].</b> This field forms the lower portion of the data COMP-MASK value, which is then bit-wise logically ANDed with the incoming data value before it is compared to the DA_COMPVAL. The “HI” and “LO” portions of the incoming data, the compare value, and the compare mask, are assembled into complete bit patterns before these operations occur.

## 4.2.3.9 DA Compare Mask High (DA\_COMPARE\_MASK\_HI[0:3])

**Data Compare Mask High****(DA\_COMPARE\_MASK\_HI[0])**

MSR Address GLIU0: 100000D3h  
 GLIU1: 400000D3h  
 Type R/W  
 Reset Value 00000000\_00000000h

**Data Compare Mask High****(DA\_COMPARE\_MASK\_HI[2])**

MSR Address GLIU0: 100000DBh  
 GLIU1: 400000DBh  
 Type R/W  
 Reset Value 00000000\_00000000h

**Data Compare Mask High****(DA\_COMPARE\_MASK\_HI[1])**

MSR Address GLIU0: 100000D7h  
 GLIU1: 400000D7h  
 Type R/W  
 Reset Value 00000000\_00000000h

**Data Compare Mask High****(DA\_COMPARE\_MASK\_HI[3])**

MSR Address GLIU0: 100000DFh  
 GLIU1: 400000DFh  
 Type R/W  
 Reset Value 00000000\_00000000h

**DA\_COMPARE\_MASK\_HI[0:3] Register Map**

63	62	61	60	59	58	57	56	55	54	53	52	51	50	49	48	47	46	45	44	43	42	41	40	39	38	37	36	35	34	33	32					
RSVD																																	DAHI_MASK			
31	30	29	28	27	26	25	24	23	22	21	20	19	18	17	16	15	14	13	12	11	10	9	8	7	6	5	4	3	2	1	0					
DAHI_MASK																																				

**DA\_COMPARE\_MASK\_HI[0:3] Bit Descriptions**

Bit	Name	Description
63:36	RSVD	<b>Reserved.</b>
35:0	DAHI_MASK	<b>DA Packet Compare Mask [80:45].</b> This field forms the upper portion of the data COMPMASK value, which is then bit-wise logically ANDed with the incoming data value before it is compared to the DA_COMPVAL. The “HI” and “LO” portions of the incoming data, the compare value, and the compare mask, are assembled into complete bit patterns before these operations occur.

**4.2.4 P2D Descriptor Registers**

P2D descriptors are ordered P2D\_BM, P2D\_BMO, P2D\_R, P2D\_RO, P2D\_SC, P2D\_BMK. For example if NP2D\_BM=3 and NP2D\_BMO=2, IMSR EO = P2D\_BM[0], MSR E3 = P2D\_SC[0].

**4.2.4.1 P2D Base Mask Descriptor (P2D\_BM)**

<b>GLIU0</b>	<b>P2D_BM[5:0]</b>	<b>GLIU1</b>	<b>P2D_BM[9:0]</b>
MSR Address	10000020h-10000025h	MSR Address	40000020h-40000029h
Type	R/W	Type	R/W
Reset Value	000000FF_FFF00000h	Reset Value	000000FF_FFF00000h

See Table 4.1.3.1 "Memory Routing and Translation" on page 47 for details on the descriptor usage.

**P2D\_BM Register Map**

63	62	61	60	59	58	57	56	55	54	53	52	51	50	49	48	47	46	45	44	43	42	41	40	39	38	37	36	35	34	33	32
PDID1			PCMP_BIZ	RSVD																			PBASE								
31	30	29		28	27	26	25	24	23	22	21	20	19	18	17	16	15	14	13	12	11	10	9	8	7	6	5	4	3	2	1
PBASE												PMASK																			

**P2D\_BM Bit Descriptions**

Bit	Name	Description
63:61	PDID1	<b>Descriptor Destination ID.</b> These bits define which Port to route the request to, if it is a 'hit' based on the other settings in this register. 000: Port 0 (GLIU0 = GLIU; GLIU1 = GLIU.) 001: Port 1 (GLIU0 = GLMC; GLIU1 = Interface to GLIU0.) 010: Port 2 (GLIU0 = Interface to GLIU1; GLIU1 = VP.) 011: Port 3 (GLIU0 = CPU Core; GLIU1 = GLCP.) 100: Port 4 (GLIU0 = DC; GLIU1 = GLPCI.) 101: Port 5 (GLIU0 = GP; GLIU1 = VIP.) 110: Port 6 (GLIU0 = Not Used; GLIU1 = SB.) 111: Port 7 (GLIU0 = Not Used; GLIU1 = Not Used.)
60	PCMP_BIZ	<b>Compare Bizzaro Flag.</b> 0: Consider only transactions whose Bizzaro flag is low as a potentially valid address hit. A low Bizzaro flag indicates a normal transaction cycle such as a memory or I/O. 1: Consider only transactions whose Bizzaro flag is high as a potentially valid address hit. A high Bizzaro flag indicates a 'special' transaction, such as a PCI Shutdown or Halt cycle.
59:40	RSVD	<b>Reserved.</b>
39:20	PBASE	<b>Physical Memory Address Base.</b> These bits form the matching value against which the masked value of the physical address, bits [31:12] are directly compared. If a match is found, then a "hit" is declared, depending on the setting of the Bizzaro flag comparator.
19:0	PMASK	<b>Physical Memory Address Mask.</b> These bits are used to mask address bits [31:12] for the purposes of this 'hit' detection.



#### 4.2.4.2 P2D Base Mask Offset Descriptor (P2D\_BMO)

<b>GLIU0</b>	<b>P2D_BMO[1:0]</b>
MSR Address	10000026h-10000027h
Type	R/W
Reset Value	0000FF0_FFF00000h

See Table 4.1.3.1 "Memory Routing and Translation" on page 47 for details on the descriptor usage.

**P2D\_BMO Register Map**

63	62	61	60	59	58	57	56	55	54	53	52	51	50	49	48	47	46	45	44	43	42	41	40	39	38	37	36	35	34	33	32
PDID1			PCMP_BIZ	POFFSET																		PBASE									
31	30	29		28	27	26	25	24	23	22	21	20	19	18	17	16	15	14	13	12	11	10	9	8	7	6	5	4	3	2	1
PBASE												PMASK																			

**P2D\_BMO Bit Descriptions**

Bit	Name	Description
63:61	PDID1	<p><b>Descriptor Destination ID.</b> These bits define which Port to route the request to, if it is a 'hit' based on the other settings in this register.</p> <p>000: Port 0 (GLIU0 = GLIU; GLIU1 = GLIU.)            001: Port 1 (GLIU0 = GLMC; GLIU1 = Interface to GLIU0.)            010: Port 2 (GLIU0 = Interface to GLIU1; GLIU1 = VP.)            011: Port 3 (GLIU0 = CPU Core; GLIU1 = GLCP.)            100: Port 4 (GLIU0 = DC; GLIU1 = GLPCI.)            101: Port 5 (GLIU0 = GP; GLIU1 = VIP.)            110: Port 6 (GLIU0 = Not Used; GLIU1 = SB.)            111: Port 7 (GLIU0 = Not Used; GLIU1 = Not Used.)</p>
60	PCMP_BIZ	<p><b>Compare Bizzaro Flag.</b></p> <p>0: Consider only transactions whose Bizzaro flag is low as a potentially valid address hit. A low Bizzaro flag indicates a normal transaction cycle such as a memory or I/O.</p> <p>1: Consider only transactions whose Bizzaro flag is high as a potentially valid address hit. A high Bizzaro flag indicates a 'special' transaction, such as a PCI Shutdown or Halt cycle.</p>
59:40	POFFSET	<p><b>Physical Memory Address 2s Comp Offset.</b> 2s complement offset that is added to physical address on a hit.</p>
39:20	PBASE	<p><b>Physical Memory Address Base.</b> These bits form the matching value against which the masked value of the physical address, bits [31:12] are directly compared. If a match is found, then a "hit" is declared, depending on the setting of the Bizzaro flag comparator.</p>
19:0	PMASK	<p><b>Physical Memory Address Mask.</b> These bits are used to mask address bits [31:12] for the purposes of this 'hit' detection.</p>

4.2.4.3 P2D Range Descriptor (P2D\_R)

<b>GLIU0</b>	<b>P2D_R[0]</b>	<b>GLIU1</b>	<b>P2D_R[3:0]</b>
MSR Address	10000028h	MSR Address	4000002Ah-4000002Dh
Type	R/W	Type	R/W
Reset Value	00000000_000FFFFFh	Reset Value	00000000_000FFFFFh

See Table 4.1.3.1 "Memory Routing and Translation" on page 47 for details on the descriptor usage.

P2D\_R Register Map

63	62	61	60	59	58	57	56	55	54	53	52	51	50	49	48	47	46	45	44	43	42	41	40	39	38	37	36	35	34	33	32
PDID1			PCMP_BIZ	RSVD																			PMAX								
31	30	29		28	27	26	25	24	23	22	21	20	19	18	17	16	15	14	13	12	11	10	9	8	7	6	5	4	3	2	1
PMAX												PMIN																			

P2D\_R Bit Descriptions

Bit	Name	Description
63:61	PDID1	<b>Descriptor Destination ID.</b> These bits define which Port to route the request to, if it is a 'hit' based on the other settings in this register. 000: Port 0 (GLIU0 = GLIU; GLIU1 = GLIU.) 001: Port 1 (GLIU0 = GLMC; GLIU1 = Interface to GLIU0.) 010: Port 2 (GLIU0 = Interface to GLIU1; GLIU1 = VP.) 011: Port 3 (GLIU0 = CPU Core; GLIU1 = GLCP.) 100: Port 4 (GLIU0 = DC; GLIU1 = GLPCI.) 101: Port 5 (GLIU0 = GP; GLIU1 = VIP.) 110: Port 6 (GLIU0 = Not Used; GLIU1 = SB.) 111: Port 7 (GLIU0 = Not Used; GLIU1 = Not Used.)
60	PCMP_BIZ	<b>Compare Bizzaro Flag.</b> 0: Consider only transactions whose Bizzaro flag is low as a potentially valid address hit. A low Bizzaro flag indicates a normal transaction cycle such as a memory or I/O. 1: Consider only transactions whose Bizzaro flag is high as a potentially valid address hit. A high Bizzaro flag indicates a 'special' transaction, such as a PCI Shutdown or Halt cycle.
59:40	RSVD	<b>Reserved.</b>
39:20	PMAX	<b>Physical Memory Address Max.</b> These bits form the value denoting the upper (ending) address of the physical memory, which is compared to determine a hit.
19:0	PMIN	<b>Physical Memory Address Min.</b> These bits form the value denoting the lower (starting) address of the physical memory, which is compared to determine a hit. Hence, a hit occurs if the physical address [31:12] >= PMIN and <= PMAX.

#### 4.2.4.4 P2D Range Offset Descriptor (P2D\_RO)

<b>GLIU0</b>	<b>P2D_RO[2:0]</b>
MSR Address	10000029h-1000002Bh
Type	R/W
Reset Value	00000000_000FFFFFh

See Table 4.1.3.1 "Memory Routing and Translation" on page 47 for details on the descriptor usage.

**P2D\_RO Register Map**

63	62	61	60	59	58	57	56	55	54	53	52	51	50	49	48	47	46	45	44	43	42	41	40	39	38	37	36	35	34	33	32
PDID1			PCMP_BIZ	OFFSET																		PMAX									
31	30	29		28	27	26	25	24	23	22	21	20	19	18	17	16	15	14	13	12	11	10	9	8	7	6	5	4	3	2	1
PMAX												PMIN																			

**P2D\_RO Bit Descriptions**

Bit	Name	Description
63:61	PDID1	<p><b>Descriptor Destination ID.</b> These bits define which Port to route the request to, if it is a 'hit' based on the other settings in this register.</p> <p>000: Port 0 (GLIU0 = GLIU; GLIU1 = GLIU.)            001: Port 1 (GLIU0 = GLMC; GLIU1 = Interface to GLIU0.)            010: Port 2 (GLIU0 = Interface to GLIU1; GLIU1 = VP.)            011: Port 3 (GLIU0 = CPU Core; GLIU1 = GLCP.)            100: Port 4 (GLIU0 = DC; GLIU1 = GLPCI.)            101: Port 5 (GLIU0 = GP; GLIU1 = VIP.)            110: Port 6 (GLIU0 = Not Used; GLIU1 = SB.)            111: Port 7 (GLIU0 = Not Used; GLIU1 = Not Used.)</p>
60	PCMP_BIZ	<p><b>Compare Bizzaro Flag.</b></p> <p>0: Consider only transactions whose Bizzaro flag is low as a potentially valid address hit. A low Bizzaro flag indicates a normal transaction cycle such as a memory or I/O.</p> <p>1: Consider only transactions whose Bizzaro flag is high as a potentially valid address hit. A high Bizzaro flag indicates a 'special' transaction, such as a PCI Shutdown or Halt cycle.</p>
59:40	POFFSET	<p><b>Physical Memory Address 2's Comp Offset.</b> 2s complement offset that is added to physical address on a hit.</p>
39:20	PMAX	<p><b>Physical Memory Address Max.</b> These bits form the value denoting the upper (ending) address of the physical memory, which is compared to determine a hit.</p>
19:0	PMIN	<p><b>Physical Memory Address Min.</b> These bits form the value denoting the lower (starting) address of the physical memory, which is compared to determine a hit. Hence, a hit occurs if the physical address [31:12] <math>\geq</math> PMIN and <math>\leq</math> PMAX.</p>

4.2.4.5 P2D Swiss Cheese Descriptor (P2D\_SC)

<b>GLIU0</b>	<b>P2D_SC[0]</b>	<b>GLIU1</b>	<b>P2D_SC[0]</b>
MSR Address	1000002Ch	MSR Address	4000002Eh
Type	R/W	Type	R/W
Reset Value	00000000_00000000h	Reset Value	00000000_00000000h

See Table 4.1.3.1 "Memory Routing and Translation" on page 47 for details on the descriptor usage.

P2D\_SC Register Map

63	62	61	60	59	58	57	56	55	54	53	52	51	50	49	48	47	46	45	44	43	42	41	40	39	38	37	36	35	34	33	32
PDID1			PCMP_BIZ	RSVD													WEN														
31	30	29		28	27	26	25	24	23	22	21	20	19	18	17	16	15	14	13	12	11	10	9	8	7	6	5	4	3	2	1
REN																RSVD	PSCBASE														

P2D\_SC Bit Descriptions

Bit	Name	Description
63:61	PDID1	<b>Descriptor Destination ID 1.</b> These bits define which Port to route the request to, if it is a 'hit' based on the other settings in this register. 000: Port 0 (GLIU0 = GLIU; GLIU1 = GLIU.) 001: Port 1 (GLIU0 = GLMC; GLIU1 = Interface to GLIU0.) 010: Port 2 (GLIU0 = Interface to GLIU1; GLIU1 = VP.) 011: Port 3 (GLIU0 = CPU Core; GLIU1 = GLCP.) 100: Port 4 (GLIU0 = DC; GLIU1 = GLPCI.) 101: Port 5 (GLIU0 = GP; GLIU1 = VIP.) 110: Port 6 (GLIU0 = Not Used; GLIU1 = SB.) 111: Port 7 (GLIU0 = Not Used; GLIU1 = Not Used.)
60	PCMP_BIZ	<b>Compare Bizzaro Flag.</b> 0: Consider only transactions whose Bizzaro flag is low as a potentially valid address hit. A low Bizzaro flag indicates a normal transaction cycle such as a memory or I/O. 1: Consider only transactions whose Bizzaro flag is high as a potentially valid address hit. A high Bizzaro flag indicates a 'special' transaction, such as a PCI Shutdown or Halt cycle.
59:48	RSVD	<b>Reserved.</b>
47:32	WEN	<b>Enable hits to the base for the ith 16K page for writes.</b> When set to 1, causes the incoming request to be routed to the port specified in PDID1 if the incoming request is a write type.
31:16	REN	<b>Enable hits to the base for the ith 16K page for reads.</b> When set to 1, causes the incoming request to be routed to the port specified in PDID1 if the incoming request is a read type.
15:14	RSVD	<b>Reserved.</b>
13:0	PBASE	<b>Physical Memory Address Base for Hit.</b> These bits form the basis of comparison with incoming checks that the physical address supplied by the device's request on address bits [31:18] are equal to PBASE. Bits [17:14] of the physical address are used to choose the ith 16K region of WEN/REN for a hit.

### 4.2.5 SPARE MSRs (SPARE\_MSR[0:9], A:F)

MSR Address      GLIU0: 10000040h-1000004Fh  
                       GLIU1: 40000040h-4000004Fh  
 Type                R/W  
 Reset Value      00000000\_00000000h

#### SPARE\_MSR[x] Register Map

63	62	61	60	59	58	57	56	55	54	53	52	51	50	49	48	47	46	45	44	43	42	41	40	39	38	37	36	35	34	33	32
SPARE_MSR																															
31	30	29	28	27	26	25	24	23	22	21	20	19	18	17	16	15	14	13	12	11	10	9	8	7	6	5	4	3	2	1	0
SPARE_MSR																															

#### SPARE\_MSR[x] Bit Descriptions

Bit	Name	Description
63:0	SPARE_MSR	Spare MSR.

**4.2.6 I/O Descriptors**

I/O descriptors are ordered IOD\_BM, IOD\_SC. For example if NIOD\_BM = 3 and NIOD\_SC = 2, MSR 10000E0h = IOD\_BM[0] and MSR 10000E3h = IOD\_SC[0].

**4.2.6.1 IOD Base Mask Descriptors (IOD\_BM)**

<b>GLIU0</b>	<b>IOD_BM[0:3]</b>	<b>GLIU1</b>	<b>IOD_BM[0:3]</b>
MSR Address	10000E0h-10000E2h	MSR Address	40000E0h-40000E2h
Type	R/W	Type	R/W
Reset Value	00000FF_FFF0000h	Reset Value	00000FF_FFF0000h

See Table 4.1.3.1 "Memory Routing and Translation" on page 47 for details on the descriptor usage.

**IOD\_BM[x] Register Map**

63	62	61	60	59	58	57	56	55	54	53	52	51	50	49	48	47	46	45	44	43	42	41	40	39	38	37	36	35	34	33	32
IDID			ICMP_BIZ	RSVD																			IBASE								
31	30	29		28	27	26	25	24	23	22	21	20	19	18	17	16	15	14	13	12	11	10	9	8	7	6	5	4	3	2	1
IBASE												IMASK																			

**IOD\_BM[x] Bit Descriptions**

Bit	Name	Description
63:61	IDID	<b>I/O Descriptor Destination ID.</b> These bits define which Port to route the request to, if it is a 'hit' based on the other settings in this register. 000: Port 0 (GLIU0 = GLIU; GLIU1 = GLIU.) 001: Port 1 (GLIU0 = GLMC; GLIU1 = Interface to GLIU0.) 010: Port 2 (GLIU0 = Interface to GLIU1; GLIU1 = VP.) 011: Port 3 (GLIU0 = CPU Core; GLIU1 = GLCP.) 100: Port 4 (GLIU0 = DC; GLIU1 = GLPCI.) 101: Port 5 (GLIU0 = GP; GLIU1 = VIP.) 110: Port 6 (GLIU0 = Not Used; GLIU1 = SB.) 111: Port 7 (GLIU0 = Not Used; GLIU1 = Not Used.)
60	ICMP_BIZ	<b>Compare Bizzaro Flag.</b> 0: Consider only transactions whose Bizzaro flag is low as a potentially valid address hit. A low Bizzaro flag indicates a normal transaction cycle such as a memory or I/O. 1: Consider only transactions whose Bizzaro flag is high as a potentially valid address hit. A high Bizzaro flag indicates a 'special' transaction, such as a PCI Shutdown or Halt cycle.
59:40	RSVD	<b>Reserved.</b>
39:20	IBASE	<b>Physical I/O Address Base.</b> These bits form the matching value against which the masked value of the physical address, bits [19:0] are directly compared. If a match is found, then a "hit" is declared, depending on the setting of the Bizzaro flag comparator.
19:0	IMASK	<b>Physical I/O Address Mask.</b> These bits are used to mask address bits [31:12] for the purposes of this 'hit' detection.

## 4.2.6.2 IOD Swiss Cheese Descriptors (IOD\_SC)

GLIU0	IOD_SC[0:5]	GLIU1	IOD_SC[0:3]
MSR Address	100000E3h-100000E8h	MSR Address	400000E3h-400000E6h
Type	R/W	Type	R/W
Reset Value	00000000_00000000h	Reset Value	00000000_00000000h

See Table 4.1.3.1 "Memory Routing and Translation" on page 47 for details on the descriptor usage.

## IOD\_SC[x] Register Map

63	62	61	60	59	58	57	56	55	54	53	52	51	50	49	48	47	46	45	44	43	42	41	40	39	38	37	36	35	34	33	32
IDID1			ICMP_BIZ	RSVD																											
31	30	29		28	27	26	25	24	23	22	21	20	19	18	17	16	15	14	13	12	11	10	9	8	7	6	5	4	3	2	1
EN								RSVD		WEN	REN	IBASE														RSVD					

## IOD\_SC[x] Bit Descriptions

Bit	Name	Description
63:61	IDID1	<b>Descriptor Destination ID 1.</b> Encoded port number of the destination of addresses which produce a 'hit' based on the other fields in this descriptor.
60	ICMP_BIZ	<b>Compare Bizzaro Flag.</b> Used to check that the Bizzaro flag of the request is equal to the ICMP_BIZ_SC bit (this bit). If a match does not occur, then the incoming request cannot generate a hit. The Bizzaro flag, if set in the incoming request, signifies a "special" cycle such as a PCI Shutdown or Halt.
59:32	RSVD	<b>Reserved.</b> Write as read.
31:24	EN	<b>Enable for Hits to IDID1 or else SUBP.</b> Setting these bits enables hits to IDID1. If not enabled, subtractive port is selected per GLD_MSR_CONFIG, bits [2:0] (MSR GLIU0: 10002001h; GLIU1: 40002001h). (See Section 4.2.1.2 "GLD Master Configuration MSR (GLD_MSR_CONFIG)" on page 55 for bit descriptions).
23:22	RSVD	<b>Reserved.</b>
21	WEN	<b>Descriptor Hits IDID1 on Write Request Types else SUBP.</b> If set, causes the incoming request to be routed to the port specified in IDID1 if the incoming request is a Write type. If not set, subtractive port is selected per GLD_MSR_CONFIG, bits [2:0] (MSR GLIU0: 10002001h; GLIU1: 40002001h). (See Section 4.2.1.2 "GLD Master Configuration MSR (GLD_MSR_CONFIG)" on page 55 for bit descriptions).
20	REN	<b>Descriptors Hit IDID1 on Read Request Types else SUBP.</b> If set, causes the incoming request to be routed to the port specified in IDID1 if the incoming request is a Read type. If not set, subtractive port is selected per GLD_MSR_CONFIG, bits [2:0] (MSR GLIU0: 10002001h; GLIU1: 40002001h). (See Section 4.2.1.2 "GLD Master Configuration MSR (GLD_MSR_CONFIG)" on page 55 for bit descriptions).
19:3	IBASE	<b>I/O Memory Base.</b> This field forms the basis of comparison with the incoming checks that the physical address supplied by the device's request on address bits [31:18] are equal to the PBASE field of descriptor register bits [13:0].
2:0	RSVD	<b>Reserved.</b> Write as read.





# CPU Core 5

This section describes the internal operations of the AMD Geode™ LX processor's CPU Core from a programmer's point of view. It includes a description of the traditional "core" processing and FPU operations. The integrated function registers are described in the next chapter.

The primary register sets within the processor core include:

- Application Register Set
- System Register Set

## 5.1 Core Processor Initialization

The CPU Core is initialized when the RESET# (Reset) signal is asserted. The CPU Core is placed in real mode and the registers listed in Table 5-1 are set to their initialized values. RESET# invalidates and disables the CPU cache,

and turns off paging. When RESET# is asserted, the CPU terminates all local bus activity and all internal execution. While RESET# is asserted, the internal pipeline is flushed and no instruction execution or bus activity occurs.

Approximately 150 to 250 external clock cycles after RESET# is de-asserted, the processor begins executing instructions at the top of physical memory (address location FFFFFFF0h). The actual number of clock cycles depends on the clock scaling in use. Also, before execution begins, an additional 2<sup>20</sup> clock cycles are needed when self-test is requested.

Typically, an intersegment jump is placed at FFFFFFF0h. This instruction forces the processor to begin execution in the lowest 1 MB of address space. Table 5-1 lists the CPU Core registers and illustrates how they are initialized.

**Table 5-1. Initialized Core Register Controls**

Register	Register Name	Initialized Contents (Note 1)	Comments
EAX	Accumulator	xxxxxxxxh	00000000h indicates self-test passed.
EBX	Base	xxxxxxxxh	
ECX	Count	xxxxxxxxh	
EDX	Data	xxxx 04 [DIR0]h	DIR0 = Device ID
EBP	Base Pointer	xxxxxxxxh	
ESI	Source Index	xxxxxxxxh	
EDI	Destination Index	xxxxxxxxh	
ESP	Stack Pointer	xxxxxxxxh	
EFLAGS	Extended Flags	00000002h	See Table 5-4 on page 93 for bit definitions.
EIP	Instruction Pointer	0000FFF0h	
ES	Extra Segment	0000h	Base address set to 00000000h. Limit set to FFFFh.
CS	Code Segment	F000h	Base address set to FFFF0000h. Limit set to FFFFh.
SS	Stack Segment	0000h	Base address set to 00000000h. Limit set to FFFFh.
DS	Data Segment	0000h	Base address set to 00000000h. Limit set to FFFFh.
FS	Extra Segment	0000h	Base address set to 00000000h. Limit set to FFFFh.
GS	Extra Segment	0000h	Base address set to 00000000h. Limit set to FFFFh.
IDTR	Interrupt Descriptor Table Register	Base = 0, Limit = 3FFh	
GDTR	Global Descriptor Table Register	xxxxxxxxh	
LDTR	Local Descriptor Table Register	xxxxh	
TR	Task Register	xxxxh	
CR0	Control Register 0	60000010h	See Table 5-10 on page 96 for bit descriptions.
CR2	Control Register 2	xxxxxxxxh	See Table 5-9 on page 96 for bit descriptions.
CR3	Control Register 3	xxxxxxxxh	See Table 5-8 on page 96 for bit descriptions.
CR4	Control Register 4	00000000h	See Table 5-7 on page 96 for bit descriptions.

Note 1. x = Undefined value.

## 5.2 Instruction Set Overview

The CPU Core instruction set can be divided into nine types of operations:

- Arithmetic
- Bit Manipulation
- Shift/Rotate
- String Manipulation
- Control Transfer
- Data Transfer
- Floating Point
- High-Level Language Support
- Operating System Support

The instructions operate on as few as zero operands and as many as three operands. A NOP (no operation) instruction is an example of a zero-operand instruction. Two-operand instructions allow the specification of an explicit source and destination pair as part of the instruction. These two-operand instructions can be divided into ten groups according to operand types:

- Register to Register
- Register to Memory
- Memory to Register
- Memory to Memory
- Register to I/O
- I/O to Register
- Memory to I/O
- I/O to Memory
- Immediate Data to Register
- Immediate Data to Memory

An operand can be held in the instruction itself (as in the case of an immediate operand), in one of the processor's registers or I/O ports, or in memory. An immediate operand is fetched as part of the opcode for the instruction.

Operand lengths of 8, 16, 32 or 48 bits are supported as well as 64 or 80 bits associated with floating-point instructions. Operand lengths of 8 or 32 bits are generally used when executing code written for 386- or 486-class (32-bit code) processors. Operand lengths of 8 or 16 bits are generally used when executing existing 8086 or 80286 code (16-bit code). The default length of an operand can be overridden by placing one or more instruction prefixes in front of the opcode. For example, the use of prefixes allows a 32-bit operand to be used with 16-bit code or a 16-bit operand to be used with 32-bit code.

The Processor Core Instruction Set (see Table 8-26 on page 634) contains the clock count table that lists each instruction in the CPU instruction set. Included in the table are the associated opcodes, execution clock counts, and effects on the EFLAGS register.

### 5.2.1 Lock Prefix

The LOCK prefix may be placed before certain instructions that read, modify, then write back to memory. The PCI will not be granted access in the middle of locked instructions. The LOCK prefix can be used with the following instructions only when the result is a write operation to memory.

- Bit Test Instructions (BTS, BTR, BTC)
- Exchange Instructions (XADD, XCHG, CMPXCHG)
- One-Operand Arithmetic and Logical Instructions (DEC, INC, NEG, NOT)
- Two-Operand Arithmetic and Logical Instructions (ADC, ADD, AND, OR, SBB, SUB, XOR).

An invalid opcode exception is generated if the LOCK prefix is used with any other instruction or with one of the instructions above when no write operation to memory occurs (for example, when the destination is a register).

### 5.2.2 Register Sets

The accessible registers in the processor are grouped into two sets:

- 1) The **Application Register Set** contains the registers frequently used by application programmers. Table 5-2 on page 91 shows the General Purpose, Segment, Instruction Pointer and EFLAGS registers.
- 2) The **System Register Set** contains the registers typically reserved for operating systems programmers: Control, System Address, Debug, Configuration, and Test registers. All accesses to these registers use special CPU instructions.

Both of these register sets are discussed in detail in the subsections that follow.

### 5.3 Application Register Set

The Application Register Set consists of the registers most often used by the applications programmer. These registers are generally accessible, although some bits in the EFLAGS registers are protected.

The **General Purpose register** contents are frequently modified by instructions and typically contain arithmetic and logical instruction operands.

In real mode, **Segment registers** contain the base address for each segment. In protected mode, the Segment registers contain segment selectors. The segment selectors provide indexing for tables (located in memory)

that contain the base address for each segment, as well as other memory addressing information.

The **Instruction Pointer register** points to the next instruction that the processor will execute. This register is automatically incremented by the processor as execution progresses.

The **EFLAGS register** contains control bits used to reflect the status of previously executed instructions. This register also contains control bits that affect the operation of some instructions.

**Table 5-2. Application Register Set**

31	30	29	28	27	26	25	24	23	22	21	20	19	18	17	16	15	14	13	12	11	10	9	8	7	6	5	4	3	2	1	0
<b>General Purpose Registers</b>																															
																AX															
																AH								AL							
EAX (Extended A Register)																															
																BX															
																BH								BL							
EBX (Extended B Register)																															
																CX															
																CH								CL							
ECX (Extended C Register)																															
																DX															
																DH								DL							
EDX (Extended D Register)																															
																SI (Source Index)															
ESI (Extended Source Index)																															
																DI (Destination Index)															
EDI (Extended Destination Index)																															
																BP (Base Pointer)															
EBP (Extended Base Pointer)																															
																SP (Stack Pointer)															
ESP (Extended Stack Pointer)																															
<b>Segment (Selector) Registers</b>																															
																CS (Code Segment)															
																SS (Stack Segment)															
																DS (D Data Segment)															
																ES (E Data Segment)															
																FS (F Data Segment)															
																GS (G Data Segment)															
<b>Instruction Pointer and EFLAGS Registers</b>																															
																EIP (Extended Instruction Pointer)															
																ESP (Extended EFLAGS Register)															

### 5.3.1 General Purpose Registers

The **General Purpose registers** are divided into four data registers, two pointer registers, and two index registers as shown in Table 5-2 on page 91.

The **Data registers** are used by the applications programmer to manipulate data structures and to hold the results of logical and arithmetic operations. Different portions of general data registers can be addressed by using different names.

An “E” prefix identifies the complete 32-bit register. An “X” suffix without the “E” prefix identifies the lower 16 bits of the register.

The lower two bytes of a data register are addressed with an “H” suffix (identifies the upper byte) or an “L” suffix (identifies the lower byte). These `_L` and `_H` portions of the data registers act as independent registers. For example, if the AH register is written to by an instruction, the AL register bits remain unchanged.

The **Pointer and Index registers** are listed below.

SI or ESI	Source Index
DI or EDI	Destination Index
SP or ESP	Stack Pointer
BP or EBP	Base Pointer

These registers can be addressed as 16- or 32-bit registers, with the “E” prefix indicating 32 bits. The Pointer and Index registers can be used as general purpose registers; however, some instructions use a fixed assignment of these registers. For example, repeated string operations always use ESI as the source pointer, EDI as the destination pointer, and ECX as a counter. The instructions that use fixed registers include multiply and divide, I/O access, string operations, stack operations, loop, variable shift and rotate, and translate instructions.

The CPU Core implements a stack using the ESP register. This stack is accessed during the PUSH and POP instructions, procedure calls, procedure returns, interrupts, exceptions, and interrupt/exception returns. The Geode LX processor automatically adjusts the value of the ESP during operations that result from these instructions.

The EBP register may be used to refer to data passed on the stack during procedure calls. Local data may also be placed on the stack and accessed with BP. This register provides a mechanism to access stack data in high-level languages.

### 5.3.2 Segment Registers

The 16-bit Segment registers are part of the main memory addressing mechanism. The six segment registers are:

CS	- Code Segment
DS	- Data Segment
SS	- Stack Segment
ES	- Extra Segment
FS	- Additional Data Segment
GS	- Additional Data Segment

The Segment registers are used to select segments in main memory. A segment acts as private memory for different elements of a program such as code space, data space and stack space. There are two segment mechanisms, one for real and virtual 8086 operating modes and one for protected mode.

The active Segment register is selected according to the rules listed in Table 5-3 and the type of instruction being currently processed. In general, the DS register selector is used for data references. Stack references use the SS register, and instruction fetches use the CS register. While some selections may be overridden, instruction fetches, stack operations, and the destination write operation of string operations cannot be overridden. Special segment-override instruction prefixes allow the use of alternate segment registers. These segment registers include the ES, FS, and GS registers.

### 5.3.3 Instruction Pointer Register

The **Instruction Pointer (EIP) register** contains the offset into the current code segment of the next instruction to be executed. The register is normally incremented by the length of the current instruction with each instruction execution unless it is implicitly modified through an interrupt, exception, or an instruction that changes the sequential execution flow (for example JMP and CALL).

**Table 5-3. Segment Register Selection Rules**

Type of Memory Reference	Implied (Default) Segment	Segment-Override Prefix
Code Fetch	CS	None
Destination of PUSH, PUSHF, INT, CALL, PUSHA instructions	SS	None
Source of POP, POPA, POPF, IRET, RET instructions	SS	None
Destination of STOS, MOVS, REP STOS, REP MOVS instructions	ES	None
Other data references with effective address using base registers of: EAX, EBX, ECX, EDX, ESI, EDI, EBP, ESP	DS SS	CS, ES, FS, GS, SS CS, DS, ES, FS, GS

### 5.3.4 EFLAGS Register

The EFLAGS register contains status information and controls certain operations on the Geode LX processor. The

lower 16 bits of this register are used when executing 8086 or 80286 code. Table 5-4 gives the bit formats for the EFLAGS register.

**Table 5-4. EFLAGS Register**

Bit	Name	Flag Type	Description
31:22	RSVD	--	<b>Reserved.</b> Set to 0.
21	ID	System	<b>Identification Bit.</b> The ability to set and clear this bit indicates that the CPUID instruction is supported. The ID can be modified only if the CPUID bit in CCR4 (Index E8h[7]) is set.
20:19	RSVD	--	<b>Reserved.</b> Set to 0.
18	AC	System	<b>Alignment Check Enable.</b> In conjunction with the AM flag (bit 18) in CR0, the AC flag determines whether or not misaligned accesses to memory cause a fault. If AC is set, alignment faults are enabled.
17	VM	System	<b>Virtual 8086 Mode.</b> If set while in protected mode, the processor switches to virtual 8086 operation handling segment loads as the 8086 does, but generating exception 13 faults on privileged opcodes. The VM bit can be set by the IRET instruction (if current privilege level is 0) or by task switches at any privilege level.
16	RF	Debug	<b>Resume Flag.</b> Used in conjunction with debug register breakpoints. RF is checked at instruction boundaries before breakpoint exception processing. If set, any debug fault is ignored on the next instruction.
15	RSVD	--	<b>Reserved.</b> Set to 0.
14	NT	System	<b>Nested Task.</b> While executing in protected mode, NT indicates that the execution of the current task is nested within another task.
13:12	IOPL	System	<b>I/O Privilege Level.</b> While executing in protected mode, IOPL indicates the maximum current privilege level (CPL) permitted to execute I/O instructions without generating an exception 13 fault or consulting the I/O permission bit map. IOPL also indicates the maximum CPL allowing alteration of the IF bit when new values are popped into the EFLAGS register.
11	OF	Arithmetic	<b>Overflow Flag.</b> Set if the operation resulted in a carry or borrow into the sign bit of the result but did not result in a carry or borrow out of the high-order bit. Also set if the operation resulted in a carry or borrow out of the high-order bit but did not result in a carry or borrow into the sign bit of the result.
10	DF	Control	<b>Direction Flag.</b> When cleared, DF causes string instructions to auto-increment (default) the appropriate index registers (ESI and/or EDI). Setting DF causes auto-decrement of the index registers to occur.
9	IF	System	<b>Interrupt Enable Flag.</b> When set, maskable interrupts (INTR input pin) are acknowledged and serviced by the CPU.
8	TF	Debug	<b>Trap Enable Flag.</b> Once set, a single-step interrupt occurs after the next instruction completes execution. TF is cleared by the single-step interrupt.
7	SF	Arithmetic	<b>Sign Flag.</b> Set equal to high-order bit of result (0 indicates positive, 1 indicates negative).
6	ZF	Arithmetic	<b>Zero Flag.</b> Set if result is zero; cleared otherwise.
5	RSVD	--	<b>Reserved.</b> Set to 0.
4	AF	Arithmetic	<b>Auxiliary Carry Flag.</b> Set when a carry out of (addition) or borrow into (subtraction) bit position 3 of the result occurs; cleared otherwise.
3	RSVD	--	<b>Reserved.</b> Set to 0.
2	PF	Arithmetic	<b>Parity Flag.</b> Set when the low-order 8 bits of the result contain an even number of ones; otherwise PF is cleared.
1	RSVD		<b>Reserved.</b> Set to 1.
0	CF	Arithmetic	<b>Carry Flag.</b> Set when a carry out of (addition) or borrow into (subtraction) the most significant bit of the result occurs; cleared otherwise.

## 5.4 System Register Set

The System Register Set, shown in Table 5-5, consists of registers not generally used by application programmers. These registers are either initialized by the system BIOS or employed by system level programmers who generate operating systems and memory management programs. Associated with the System Register Set are certain tables and registers that are listed in Table 5-5.

The **Control registers** control certain aspects of the CPU Core such as paging, coprocessor functions, and segment protection.

The **CPU Core Configuration registers** are used to initialize, provide for, test or define most of the features of the CPU Core. The attributes of these registers include:

- CPU setup - Enable cache, features, operating modes.
- Debug support - Provide debugging facilities for the Geode™ LX processor and enable the use of data access breakpoints and code execution breakpoints.
- Built-in Self-test (BIST) support.
- Test - Support a mechanism to test the contents of the on-chip caches and the Translation Lookaside Buffers (TLBs).
- In-Circuit Emulation (ICE) - Provide for an alternative accessing path to support an ICE.
- CPU identification - Allow the BIOS and other software to identify the specific CPU and stepping.
- Power Management.
- Performance Monitoring - Enables test software to measure the performance of application software.

The **Descriptor Table registers** point to tables used to manage memory segments and interrupts.

The **Task State register** points to the Task State Segment, which is used to save and load the processor state when switching tasks.

Table 5-5 lists the System Register Sets along with their size and function.

**Table 5-5. System Register Set**

Group	Name	Function	Width (Bits)
Control Registers	CR0	System Control Register	32
	CR2	Page Fault Linear Address Register	32
	CR3	Page Directory Base Register	32
	CR4	Feature Enables	32
CPU Core Configuration Registers	PLn	Pipeline Control Registers	64
	IMn	Instruction Memory Control Registers	64
	DMn	Data Memory Control Registers	64
	BCn	Bus Controller Control Registers	64
	FPU <sub>n</sub>	Floating Point Unit Shadow Registers	64
Descriptor Table Registers	GDTR	GDT Register	32
	IDTR	IDT Register	32
	LDTR	LDT Register	16
Task Register	TR	Task Register	16
Performance Registers	PCR <sub>n</sub>	Performance Control Registers	8

### 5.4.1 Control Registers

A map of the Control registers (CR0, CR1, CR2, CR3, and CR4) is shown in Table 5-6 and the bit descriptions are in the tables that follow. (These registers should not be confused with the CRRn registers.) CR0 contains system control bits that configure operating modes and indicate the general state of the CPU. The lower 16 bits of CR0 are referred to as the Machine Status Word (MSW).

When operating in real mode, any program can read and write the control registers. In protected mode, however, only privilege level 0 (most-privileged) programs can read and write these registers.

#### L1 Cache Controller

The Geode LX processor contains an on-board 64 KB L1 instruction cache, a 64 KB L1 write-back data cache, and a 128 KB unified L2 victim cache. With the memory controller on-board, the L1 cache requires no external logic to maintain coherency. All DMA cycles automatically snoop the L1 and L2 caches.

The CD bit (Cache Disable, bit 30) in CR0 globally controls the operating mode of the L1 and L2 caches. LCD and LWT, Local Cache Disable and Local Write-through bits in the Translation Lookaside Buffer, control the mode on a page-by-page basis. Additionally, memory configuration control can specify certain memory regions as non-cacheable.

If the cache is disabled, no further cache line fills occur. However, data already present in the cache continues to be used. For the cache to be completely disabled, the cache must be invalidated with a WBINVD instruction after the cache has been disabled.

Write-back caching improves performance by relieving congestion on slower external buses.

The Geode LX processor caches SMM regions, reducing system management overhead to allow for hardware emulation such as VGA.

**Table 5-6. Control Registers Map**

31	30	29	28	27	26	25	24	23	22	21	20	19	18	17	16	15	14	13	12	11	10	9	8	7	6	5	4	3	2	1	0
<b>CR4 Register      Control Register 4 (R/W)</b>																															
RSVD																								PCE	PGE	RSVD		PSE	DE	TSC	RSVD
<b>CR3 Register      Control Register 3 (R/W)</b>																															
PDBR (Page Directory Base Register)																RSVD						0	0	RSVD							
<b>CR2 Register      Control Register 2 (R/W)</b>																															
PFLA (Page Fault Linear Address)																															
<b>CR1 Register      Control Register 1 (R/W)</b>																															
RSVD																															
<b>CR0 Register      Control Register 0 (R/W)</b>																															
PG	CD	NW	RSVD											AM	RSVD	WP	RSVD						NE	RSVD	TS	EM	MP	PE			
Machine Status Word (MSW)																															

**Table 5-7. CR4 Bit Descriptions**

Bit	Name	Description
31:9	RSVD	<b>Reserved.</b> Set to 0 (always returns 0 when read).
8	PCE	<b>Performance Counter Enable.</b> Set PCE = 1 to make RDPMC available at nonzero privilege levels.
7	PGE	<b>Page Global Enable.</b> Set PGE = 1 to make global pages immune to INVLPG instructions.
6:5	RSVD	<b>Reserved.</b> Set to 0 (always returns 0 when read).
4	PSE	<b>Page Size Extensions.</b> Set PSE = 1 to enable 4 MB pages.
3	DE	<b>Debug Extensions.</b> Set DE = 1 to enable debug extensions (i.e., DR4, DR5, and I/O breakpoints).
2	TSC	<b>Time Stamp Counter Instruction.</b> 0: RDTSC instruction enabled for all CPL states. 1: RDTSC instruction enabled for CPL = 0 only.
1:0	RSVD	<b>Reserved.</b> Set to 0 (always returns 0 when read).

**Table 5-8. CR3 Bit Descriptions**

Bit	Name	Description
31:12	PDBR	<b>Page Directory Base Register.</b> Identifies page directory base address on a 4 KB page boundary.
11:0	RSVD	<b>Reserved.</b> Set to 0.

**Table 5-9. CR2 Bit Descriptions**

Bit	Name	Description
31:0	PFLA	<b>Page Fault Linear Address.</b> With paging enabled and after a page fault, PFLA contains the linear address of the address that caused the page fault.

**Table 5-10. CR0 Bit Descriptions**

Bit	Name	Description
31	PG	<b>Paging Enable Bit.</b> If PG = 1 and protected mode is enabled (PE = 1), paging is enabled. After changing the state of PG, software must execute an unconditional branch instruction (e.g., JMP, CALL) to have the change take effect.



Table 5-10. CR0 Bit Descriptions (Continued)

Bit	Name	Description
30	CD	<b>Cache Disable/Not Write-Through (Snoop).</b> Cache behavior is based on the CR0 CD and NW bits. CD    NW 0    0    Normal Cache operation, coherency maintained. Read hits access the cache, Write hits update the cache, Read/write misses may cause line allocations based on memory region configuration settings. 0    1    Invalid, causes a General Protection Fault (GPF). 1    0    Cache off, coherency maintained (i.e., snooping enabled). Read hits access the cache, Write hits update the cache, Read/write misses do not cause line allocations. 1    1    Cache off, coherency not maintained (i.e., snooping disabled). Read hits access the cache, Write hits update the cache, Read/write misses do not cause line allocations.
29	NW	
28:19	RSVD	<b>Reserved.</b>
18	AM	<b>Alignment Check Mask.</b> If AM = 1, the AC bit in the EFLAGS register is unmasked and allowed to enable alignment check faults. Setting AM = 0 prevents AC faults from occurring.
17	RSVD	<b>Reserved</b>
16	WP	<b>Write Protect.</b> Protects read only pages from supervisor write access. WP = 0 allows a read only page to be written from privilege level 0-2. WP = 1 forces a fault on a write to a read only page from any privilege level.
15:6	RSVD	<b>Reserved.</b>
5	NE	<b>Numerics Exception.</b> NE = 1 to allow FPU exceptions to be handled by interrupt 16. NE = 0 if FPU exceptions are to be handled by external interrupts.
4	ET (RO)	<b>Extension Type (Read Only).</b> (Default = 1)
3	TS	<b>Task Switched.</b> Set whenever a task switch operation is performed. Execution of a floating point instruction with TS = 1 causes a Device Not Available (DNA) fault. If MP = 1 and TS = 1, a WAIT instruction also causes a DNA fault. (Note 1)
2	EM	<b>Emulate Processor Extension.</b> If EM = 1, all floating point instructions cause a DNA fault 7. (Note 1)
1	MP	<b>Monitor Processor Extension.</b> If MP = 1 and TS = 1, a WAIT instruction causes DNA fault 7. The TS bit is set to 1 on task switches by the CPU. Floating point instructions are not affected by the state of the MP bit. The MP bit should be set to 1 during normal operations. (Note 1)
0	PE	<b>Protected Mode Enable.</b> Enables the segment based protection mechanism. If PE = 1, protected mode is enabled. If PE = 0, the CPU operates in real mode and addresses are formed as in an 8086-style CPU.

Note 1. For effects of various combinations of the TS, EM, and MP bits, see Table 5-11 on page 98.

Table 5-11. Effects of Various Combinations of EM, TS, and MP Bits

CR0[3:1]			Instruction Type	
TS	EM	MP	WAIT	ESC
0	0	0	Execute	Execute
0	0	1	Execute	Execute
1	0	0	Execute	Fault 7
1	0	1	Fault 7	Fault 7
0	1	0	Execute	Fault 7
0	1	1	Execute	Fault 7
1	1	0	Execute	Fault 7
1	1	1	Fault 7	Fault 7

## 5.5 CPU Core Register Descriptions

All CPU Core registers are Model Specific Registers (MSRs) and are accessed via the RDMSR and WRMSR instructions.

Each module inside the processor is assigned a 256 register section of the address space. The module responds to any reads or writes in that range. Unused addresses within a module's address space are reserved, meaning the module returns zeroes on a read and ignores writes. Addresses that are outside all the module address spaces are invalid,

meaning a RDMSR/WRMSR instruction attempting to use the address generates a General Protection Fault.

The registers associated with the CPU Core are the Standard GeodeLink™ Device MSRs and CPU Core Specific MSRs. Table 5-12 and Table 5-13 are register summary tables that include reset values and page references where the bit descriptions are provided. Note that the standard GLD MSRs for the CPU Core start at 00002000h.

**Table 5-12. Standard GeodeLink™ Device MSRs Summary**

MSR Address	Type	Register Name	Reset Value	Reference
00002000h	RO	GLD Capabilities MSR (GLD_MSR_CAP)	00000000_000864xxh	Page 108
00002001h	R/W	GLD Master Configuration MSR (GLD_MSR_CONFIG)	00000000_00000320h	Page 108
00002002h	R/W	GLD SMI MSR (GLD_MSR_SMI) - Not Used	00000000_00000000h	Page 109
00002003h	R/W	GLD Error MSR (GLD_MSR_ERROR) - Not Used	00000000_00000000h	Page 109
00002004h	R/W	GLD Power Management MSR (GLD_MSR_PM) - Not Used	00000000_00000000h	Page 109
00002005h	R/W	GLD Diagnostic Bus Control MSR (GLD_MSR_DIAG)	00000000_00000000h	Page 109

**Table 5-13. CPU Core Specific MSRs Summary**

MSR Address	Type	Register Name	Reset Value	Reference
00000010h	R/W	Time Stamp Counter MSR (TSC_MSR)	00000000_00000000h	Page 110
000000C1h	R/W	Performance Event Counter 0 MSR (PERF_CNT0_MSR)	00000000_00000000h	Page 110
000000C2h	R/W	Performance Event Counter 1 MSR (PERF_CNT1_MSR)	00000000_00000000h	Page 111
00000174h	R/W	SYSENTER/SYSEXIT Code Segment Selector MSR (SYS_CS_MSR)	00000000_C09B0000h	Page 112
00000175h	R/W	SYSENTER/SYSEXIT Stack Pointer MSR (SYS_SP_MSR)	00000000_00000000h	Page 113
00000176h	R/W	SYSENTER/SYSEXIT Instruction Pointer MSR (SYS_IP_MSR)	00000000_00000000h	Page 113
00000186h	R/W	Performance Event Counter 0 Select MSR (PERF_SEL0_MSR)	00000000_00000000h	Page 114
00000187h	R/W	Performance Event Counter 1 Select MSR (PERF_SEL1_MSR)	00000000_00000000h	Page 114
00001100h	R/W	Instruction Fetch Configuration MSR (IF_CONFIG_MSR)	00000000_00005051h	Page 115
00001102h	W	IF Invalidate MSR (IF_INVALIDATE_MSR)	00000000_00000000h	Page 118
00001108h	R/W	IF Test Address MSR (IF_TEST_ADDR_MSR)	00000000_00000000h	Page 118
00001109h	R/W	IF Test Data MSR (IF_TEST_DATA_MSR)	00000000_xxxxxxxxh	Page 119

Table 5-13. CPU Core Specific MSRs Summary (Continued)

MSR Address	Type	Register Name	Reset Value	Reference
00001110h	RO	IF Sequential Count MRS (IF_SEQCOUNT_MSR)	00000000_00000000h	Page 122
00001140h	RO	IF Built-In Self-Test MSR (IF_BIST_MSR)	00000000_00000000h	Page 123
00001210h	R/W	Exception Unit (XC) Configuration MSR (XC_CONFIG_MSR)	00000000_00000000h	Page 124
00001211h	R/W	XC Mode MSR (XC_MODE_MSR)	00000000_00000000h	Page 125
00001212h	RO	XC History MSR (XC_HIST_MSR)	00000000_00000000h	Page 126
00001213h	RO	XC Microcode Address MSR (XC_UADDR_MSR)	00000000_00000000h	Page 127
00001250h	R/W	ID Configuration MSR (ID_CONFIG_MSR)	00000000_00000002h	Page 127
00001301h	R/W	SMM Control MSR (SMM_CTL_MSR)	00000000_00000000h	Page 128
00001302h	R/W	Debug Management Interrupt (DMI) Control Register	00000000_00000000h	Page 129
00001310h	R/W	Temporary 0 MSR (TEMP0_MSR)	xxxxxxxx_xxxxxxxxxh	Page 130
00001311h	R/W	Temporary 1 MSR (TEMP1_MSR)	xxxxxxxx_xxxxxxxxxh	Page 130
00001312h	R/W	Temporary 2 MSR (TEMP2_MSR)	xxxxxxxx_xxxxxxxxxh	Page 130
00001313h	R/W	Temporary 3 MSR (TEMP3_MSR)	xxxxxxxx_xxxxxxxxxh	Page 130
00001320h	R/W	ES Segment Selector/Flags Register (ES_SEL_MSR)	xxxxxxxx_xxxxxxxxxh	Page 131
00001321h	R/W	CS Segment Selector/Flags Register (CS_SEL_MSR)	xxxxxxxx_xxxxxxxxxh	Page 131
00001322h	R/W	SS Segment Selector/Flags Register (SS_SEL_MSR)	xxxxxxxx_xxxxxxxxxh	Page 131
00001323h	R/W	DS Segment Selector/Flags Register (DS_SEL_MSR)	xxxxxxxx_xxxxxxxxxh	Page 131
00001324h	R/W	FS Segment Selector/Flags Register (FS_SEL_MSR)	xxxxxxxx_xxxxxxxxxh	Page 131
00001325h	R/W	GS Segment Selector/Flags Register (GS_SEL_MSR)	xxxxxxxx_xxxxxxxxxh	Page 131
00001326h	R/W	LDT Segment Selector/Flags Register (LDT_SEL_MSR)	xxxxxxxx_xxxxxxxxxh	Page 131
00001327h	R/W	Temp Segment Selector/Flags Register (TM_SEL_MSR)	xxxxxxxx_xxxxxxxxxh	Page 131
00001328h	R/W	TSS Segment Selector/Flags Register (TSS_SEL_MSR)	xxxxxxxx_xxxxxxxxxh	Page 131
00001329h	R/W	IDT Segment Selector/Flags Register (IDT_SEL_MSR)	xxxxxxxx_xxxxxxxxxh	Page 131
0000132Ah	R/W	GDT Segment Selector/Flags Register (GDT_SEL_MSR)	xxxxxxxx_xxxxxxxxxh	Page 131
0000132Bh	R/W	SMM Header MSR (SMM_HDR_MSR)	00000000_00000000h	Page 132
0000132Ch	R/W	DMM Header MSR (DMM_HDR_MSR)	00000000_00000000h	Page 133
00001330h	R/W	ES Segment Base/Limit MSR (ES_BASE_MSR)	xxxxxxxx_xxxxxxxxxh	Page 134
00001331h	R/W	CS Segment Base/Limit MSR (CS_BASE_MSR)	xxxxxxxx_xxxxxxxxxh	Page 134
00001332h	R/W	SS Segment Base/Limit MSR (SS_BASE_MSR)	xxxxxxxx_xxxxxxxxxh	Page 134
00001333h	R/W	DS Segment Base/Limit MSR (DS_BASE_MSR)	xxxxxxxx_xxxxxxxxxh	Page 134
00001334h	R/W	FS Segment Base/Limit MSR (FS_BASE_MSR)	xxxxxxxx_xxxxxxxxxh	Page 134

Table 5-13. CPU Core Specific MSRs Summary (Continued)

MSR Address	Type	Register Name	Reset Value	Reference
00001335h	R/W	GS Segment Base/Limit MSR (GS_BASE_MSR)	xxxxxxxx_xxxxxxxxh	Page 134
00001336h	R/W	LDT Segment Base/Limit MSR (LDT_BASE_MSR)	xxxxxxxx_xxxxxxxxh	Page 134
00001337h	R/W	Temp Segment Base/Limit MSR (TEMP_BASE_MSR)	xxxxxxxx_xxxxxxxxh	Page 134
00001338h	R/W	TSS Segment Base/Limit MSR (TSS_BASE_MSR)	xxxxxxxx_xxxxxxxxh	Page 134
00001339h	R/W	IDT Segment Base/Limit MSR (IDT_BASE_MSR)	xxxxxxxx_xxxxxxxxh	Page 134
0000133Ah	R/W	GDT Segment Base/Limit MSR (GDT_BASE_MSR)	xxxxxxxx_xxxxxxxxh	Page 134
0000133Bh	R/W	SMM Segment Base/Limit MSR (SMM_BASE_MSR)	xxxxxxxx_xxxxxxxxh	Page 134
0000133Ch	R/W	DMM Segment Base/ Limit MSR (DMM_BASE_MSR)	xxxxxxxx_xxxxxxxxh	Page 134
00001340h	R/W	Debug Registers 1 and 0 MSR (DR1_DR0_MSR)	xxxxxxxx_xxxxxxxxh	Page 135
00001341h	R/W	Debug Registers 3 and 2 MSR (DR3_DR2_MSR)	xxxxxxxx_xxxxxxxxh	Page 135
00001343h	R/W	Debug Registers 7 and 6 MSR (DR6_DR7_MSR)	00000000_FFFF0000h	Page 136
00001350h	R/W	Extended Debug Registers 1 and 0 MSR (XDR1_XDR0_MSR)	00000000_00000000h	Page 137
00001351h	R/W	Extended Debug Registers 3 and 2 MSR (XDR3_XDR2_MSR)	00000000_00000000h	Page 137
00001352h	R/W	Extended Debug Registers 5 and 4 MSR (XDR5_XDR4_MSR)	FFFFFFFF_00000000h	Page 138
00001353h	R/W	Extended Debug Registers 7 and 6 MSR (XDR7_XDR6_MSR)	xxxxxxxx_xxxxxxxxh	Page 138
00001354h	R/W	Extended Debug Registers 9 and 8 MSR (XDR9_XDR8_MSR)	FFFFFFFF_00000000h	Page 140
00001355h	R/W	Extended Debug Registers 11 and 10 MSR (XDR11_XDR10_MSR)	xxxxxxxx_xxxx0000h	Page 141
00001360h	R/W	EX Stage Instruction Pointer MSR (EX_IP_MSR)	00000000_00000000h	Page 141
00001361h	R/W	WB Stage Instruction Pointer MSR (WB_IP_MSR)	00000000_00000000h	Page 142
00001364h	RO	EX Stage Linear Instruction Pointer MSR (EX_LIP_MSR)	00000000_00000000h	Page 142
00001365h	RO	WB Stage Linear Instruction Pointer MSR (WB_LIP_MSR)	00000000_00000000h	Page 143
00001366h	RO	C1/C0 Linear Instruction Pointer MSR (C1_C0_LIP_MSR)	00000000_00000000h	Page 143
00001367h	RO	C3/C2 Linear Instruction Pointer MSR (C3_C2_LIP_MSR)	00000000_00000000h	Page 144
00001370h	R/W	Floating Point Environment Code Segment (FPENV_CS_MSR)	00000000_00000000h	Page 144
00001371h	R/W	Floating Point Environment Instruction Pointer (FPENV_IP_MSR)	00000000_00000000h	Page 145
00001372h	R/W	Floating Point Environment Data Segment (FPENV_DS_MSR)	00000000_00000000h	Page 145
00001373h	R/W	Floating Point Environment Data Pointer (FPENV_DP_MSR)	00000000_00000000h	Page 146

Table 5-13. CPU Core Specific MSRs Summary (Continued)

MSR Address	Type	Register Name	Reset Value	Reference
00001374h	R/W	Floating Point Environment Opcode Pointer (FPENV_OP_MSR)	00000000_00000000h	Page 146
00001380h	RO	Address Calculation Unit Configuration MSR (AC_CONFIG_MSR)	00000000_00000000h	Page 147
00001408h	R/W	General Register EAX MSR (GR_EAX_MSR)	00000000_00000000h	Page 148
00001409h	R/W	General Register ECX MSR (GR_ECX_MSR)	00000000_00000000h	Page 148
0000140Ah	R/W	General Register EDX MSR (GR_EDX_MSR)	00000000_00000000h	Page 148
0000140Bh	R/W	General Register EBX MSR (GR_EBX_MSR)	00000000_00000000h	Page 148
0000140Ch	R/W	General Register ESP MSR (GR_ESP_MSR)	00000000_00000000h	Page 148
0000140Dh	R/W	General Register EBP MSR (GR_EBP_MSR)	00000000_00000000h	Page 148
0000140Eh	R/W	General Register ESI MSR (GR_ESI_MSR)	00000000_00000000h	Page 148
0000140Fh	R/W	General Register EDI MSR (GR EDI_MSR)	00000000_00000000h	Page 148
00001410h	R/W	General Register Temp 0 MSR (GR_TEMP0_MSR)	00000000_00000000h	Page 148
00001411h	R/W	General Register Temp 1 MSR (GR_TEMP1_MSR)	00000000_00000000h	Page 148
00001412h	R/W	General Register Temp 2 MSR (GR_TEMP2_MSR)	00000000_00000000h	Page 148
00001413h	R/W	General Register Temp 3 MSR (GR_TEMP3_MSR)	00000000_00000000h	Page 148
00001414h	R/W	General Register Temp 4 MSR (GR_TEMP4_MSR)	00000000_00000000h	Page 148
00001415h	R/W	General Register Temp 5 MSR (GR_TEMP5_MSR)	00000000_00000000h	Page 148
00001416h	R/W	General Register Temp 6 MSR (GR_TEMP6_MSR)	00000000_00000000h	Page 148
00001417h	R/W	General Register Temp 7 MSR (GR_TEMP7_MSR)	00000000_00000000h	Page 148
00001418h	R/W	Extended Flags MSR (EFLAG_MSR)	00000000_00000002h	Page 149
00001420h	R/W	Control Register 0 MSR (CR0_MSR)	00000000_60000010h	Page 149
00001700h	R/W	Instruction Memory Configuration MSR (IM_CONFIG_MSR)	00000000_00000000h	Page 150
00001710h	R/W	Instruction Cache Index MSR (IC_INDEX_MSR)	00000000_00000000h	Page 152
00001711h	R/W	Instruction Cache Data MSR (IC_DATA_MSR)	xxxxxxxx_xxxxxxxxh	Page 152
00001712h	R/W	Instruction Cache Tag (IC_TAG_MSR)	00000000_00000000h	Page 153
00001713h	R/W	Instruction Cache Tag with Increment (IC_TAG_I_MSR)	00000000_00000000h	Page 154
00001714h	RO	L0 Instruction Cache Data MSR (L0_IC_DATA_MSR)	xxxxxxxx_xxxxxxxxh	Page 154
00001715h	RO	L0 Instruction Cache Tag with Increment MSR (L0_IC_TAG_I_MSR)	00000000_xxxxxxxxh	Page 154
00001720h	R/W	L1 Instruction TLB Index (ITB_INDEX_MSR)	00000000_0000000xh	Page 155
00001721h	R/W	L1 Instruction TLB Least Recently Used MSR (ITB_LRU_MSR)	00000000_00000000h	Page 156

Table 5-13. CPU Core Specific MSRs Summary (Continued)

MSR Address	Type	Register Name	Reset Value	Reference
00001722h	R/W	ITB Entry MSR (ITB_ENTRY_MSR)	xxxxxxxx_xxxxxxxh	Page 157
00001723h	R/W	ITB Entry with Increment MSR (ITB_ENTRY_I_MSR)	xxxxxxxx_xxxxxxxh	Page 157
00001724h	R/W	ITB L0 Cache Entry MSR (ITB_L0_ENTRY_MSR)	xxxxxxxx_xxxxxxxh	Page 157
00001730h	RO	Instruction Memory Subsystem BIST Tag MSR (IM_BIST_TAG_MSR)	00000000_0000000xh	Page 158
00001731h	RO	Instruction Memory Subsystem BIST Data MSR (IM_BIST_DATA_MSR)	00000000_0000000xh	Page 158
00001800h	R/W	Data Memory Subsystem Configuration 0 MSR (DM_CONFIG0_MSR)	00000000_00000000h	Page 159
00001801h	R/W	Data Memory Subsystem Configuration 1 MSR (DM_CONFIG1_MSR)	00000000_00000000h	Page 162
00001804h	R/W	Data Memory Subsystem Prefetch Lock MSR (DM_PFLOCK_MSR)	00000000_00000000h	Page 163
00001808h	R/W	Default Region Configuration Properties MSR (RCONF_DEFAULT_MSR)	01FFFFFF0_1000001h Warm Start Value: 04xxxxx0_1xxxx01h	Page 164
0000180Ah	R/W	Region Configuration Bypass MSR (RCONF_BYPASS_MSR)	00000000_0000101h Warm Start Value: 00000000_00000219h	Page 165
0000180Bh	R/W	Region Configuration A0000-BFFFF MSR (RCONF_A0_BF_MSR)	01010101_01010101h Warm Start Value: 19191919_19191919h	Page 165
0000180Ch	R/W	Region Configuration C0000-DFFFF MSR (RCONF_C0_DF_MSR)	01010101_01010101h Warm Start Value: 19191919_19191919h	Page 166
0000180Dh	R/W	Region Configuration E0000-FFFFFF MSR (RCONF_E0_FF_MSR)	01010101_01010101h Warm Start Value: 19191919_19191919h	Page 166
0000180Eh	R/W	Region Configuration SMM MSR (RCONF_SMM_MSR)	00000001_00000001h Warm Start Value: xxxxx001_xxxxx005h	Page 167
0000180Fh	R/W	Region Configuration DMM MSR (RCONF_DMM_MSR)	00000001_00000001h Warm Start Value: xxxxx001_xxxxx005h	Page 168
00001810h	R/W	Region Configuration Range 0 MSR (RCONF0_MSR)	00000000_00000000h Warm Start Value: xxxxx000_xxxxx0xxh	Page 169
00001811h	R/W	Region Configuration Range 1 MSR (RCONF1_MSR)	00000000_00000000h Warm Start Value: xxxxx000_xxxxx0xxh	Page 169
00001812h	R/W	Region Configuration Range 2 MSR (RCONF2_MSR)	00000000_00000000h Warm Start Value: xxxxx000_xxxxx0xxh	Page 169

Table 5-13. CPU Core Specific MSRs Summary (Continued)

MSR Address	Type	Register Name	Reset Value	Reference
00001813h	R/W	Region Configuration Range 3 MSR (RCONF3_MSR)	00000000_00000000h	Page 169
			Warm Start Value: xxxxx000_xxxxx0xxh	
00001814h	R/W	Region Configuration Range 4 MSR (RCONF4_MSR)	00000000_00000000h	Page 169
			Warm Start Value: xxxxx000_xxxxx0xxh	
00001815h	R/W	Region Configuration Range 5 MSR (RCONF5_MSR)	00000000_00000000h	Page 169
			Warm Start Value: xxxxx000_xxxxx0xxh	
00001816h	R/W	Region Configuration Range 6 MSR (RCONF6_MSR)	00000000_00000000h	Page 169
			Warm Start Value: xxxxx000_xxxxx0xxh	
00001817h	R/W	Region Configuration Range 7 MSR (RCONF7_MSR)	00000000_00000000h	Page 169
			Warm Start Value: xxxxx000_xxxxx0xxh	
00001881h	R/W	x86 Control Register 1 MSR (CR1_MSR)	00000000_xxxxxxxxh	Page 172
00001882h	R/W	x86 Control Register 2 MSR (CR2_MSR)	00000000_xxxxxxxxh	Page 172
00001883h	R/W	x86 Control Register 3 MSR (CR3_MSR)	00000000_xxxxxxxxh	Page 172
00001884h	R/W	x86 Control Register 4 MSR (CR4_MSR)	00000000_xxxxxxxxh	Page 172
00001890h	R/W	Data Cache Index MSR (DC_INDEX_MSR)	00000000_00000000h	Page 172
00001891h	R/W	Data Cache Data MSR (DC_DATA_MSR)	00000000_00000000h	Page 173
00001892h	R/W	Data Cache Tag MSR (DC_TAG_MSR)	00000000_00000000h	Page 173
00001893h	R/W	Data Cache Tag with Increment MSR (DC_TAG_I_MSR)	00000000_00000000h	Page 174
00001894h	WO	Data/Instruction Cache Snoop Register (SNOOP_MSR)	00000000_xxxxxxxxh	Page 175
00001898h	R/W	L1 Data TLB Index Register (L1DTLB_INDEX_MSR)	00000000_00000000h	Page 175
00001899h	R/W	L1 Data TLB Least Recently Used MSR (L1DTLB_LRU_MSR)	00000000_00000000h	Page 176
0000189Ah	R/W	L1 Data TLB Entry MSR (L1DTLB_ENTRY_MSR)	00000000_00000000h	Page 177
0000189Bh	R/W	L1 Data TLB Entry with Increment MSR (L1DTLB_ENTRY_I_MSR)	00000000_00000000h	Page 178
0000189Ch	R/W	L2 TLB/DTE/PTE Index MSR (L2TLB_INDEX_MSR)	00000000_00000000h	Page 178
0000189Dh	R/W	L2 TLB/DTE/PTE Least Recently Used MSR (L2TLB_LRU_MSR)	00000000_00000000h	Page 179
0000189Eh	R/W	L2 TLB/DTE/PTE Entry MSR (L2TLB_ENTRY_MSR)	00000000_00000000h	Page 180
0000189Fh	R/W	L2 TLB/DTE/PTE Entry with Increment MSR (L2TLB_ENTRY_I_MSR)	00000000_00000000h	Page 182
000018C0h	R/W	Data Memory Subsystem Built-In Self-Test MSR (DM_BIST_MSR)	00000000_00000000h	Page 182
00001900h	R/W	Bus Controller Configuration 0 MSR (BC_CONFIG0_MSR)	00000000_00000111h	Page 183



Table 5-13. CPU Core Specific MSRs Summary (Continued)

MSR Address	Type	Register Name	Reset Value	Reference
00001901h	R/W	Bus Controller Configuration 1 MSR (BC_CONFIG1_MSR)	00000000_00000000h	Page 184
00001904h	RO	Reserved Status MSR (RSVD_STS_MSR)	00000000_00000000h	Page 185
00001908h	R/W	MSR Lock MSR (MSR_LOCK_MSR)	00000000_00000000h	Page 185
00001910h	R/W	Real Time Stamp Counter MSR (RTSC_MSR)	00000000_00000000h	Page 186
00001911h	RO	TSC and RTSC Low DWORDs MSR (RTSC_TSC_MSR)	00000000_00000000h	Page 186
00001920h	R/W	L2 Cache Configuration MSR (L2_CONFIG_MSR)	00000000_000000Eh	Page 187
00001921h	RO	L2 Cache Status MSR (L2_STATUS_MSR)	00000000_00000001h	Page 188
00001922h	R/W	L2 Cache Index MSR (L2_INDEX_MSR)	00000000_00000000h	Page 188
00001923h	R/W	L2 Cache Data MSR (L2_DATA_MSR)	00000000_00000000h	Page 189
00001924h	R/W	L2 Cache Tag MSR (L2_TAG_MSR)	00000000_00000000h	Page 189
00001925h	R/W	L2 Cache Tag with Increment MSR (L2_TAG_I_MSR)	00000000_00000000h	Page 190
00001926h	R/W	L2 Cache Built-In Self-Test MSR (L2_BIST_MSR)	00000000_00000000h	Page 190
00001927h	R/W	L2 Cache Treatment Control MSR (L2_TRTMNT_CTL_MSR)	00000000_00000000h	Page 192
00001930h	R/W	Power Mode MSR (PMODE_MSR)	00000000_00000300h	Page 193
00001950h	R/W	Bus Controller Extended Debug Registers 1 and 0 MSR (BXDR1_BXDR0_MSR)	00000000_00000000h	Page 194
00001951h	R/W	Bus Controller Extended Debug Registers 3 and 2 MSR (BXDR3_BXDR2_MSR)	00000000_00000000h	Page 194
00001953h	R/W	Bus Controller Extended Debug Registers 6 and 7 MSR (BXDR6_BXDR7_MSR)	00000000_00000000h	Page 195
00001970h	R/W	Bus Controller Debug Register 0 MSR (BDR0_MSR)	00000000_00000000h	Page 197
00001971h	R/W	Bus Controller Debug Register 1 MSR (BDR1_MSR)	00000000_00000000h	Page 197
00001972h	R/W	Bus Controller Debug Register 2 MSR (BDR2_MSR)	00000000_00000000h	Page 197
00001973h	R/W	Bus Controller Debug Register 3 MSR (BDR3_MSR)	00000000_00000000h	Page 197
00001976h	R/W	Bus Controller Debug Register 6 MSR (BDR6_MSR)	00000000_00000000h	Page 198
00001977h	R/W	Bus Controller Debug Register 7 MSR (BDR7_MSR)	00000000_00000000h	Page 198
00001980h	R/W	Memory Subsystem Array Control Enable MSR (MSS_ARRAY_CTL_EN_MSR)	00000000_00000000h	Page 200
00001981h	R/W	Memory Subsystem Array Control 0 MSR (MSS_ARRAY_CTL0_MSR)	00000000_2010F3C9h	Page 200
00001982h	R/W	Memory Subsystem Array Control 1 MSR (MSS_ARRAY_CTL1_MSR)	00000000_104823CFh	Page 201
00001983h	R/W	Memory Subsystem Array Control 2 MSR (MSS_ARRAY_CTL2_MSR)	00000104_820C30C3h	Page 201
00001A00h	R/W	FPU Modes MSR (FP_MODE_MSR)	00000000_00000000h	Page 202

Table 5-13. CPU Core Specific MSRs Summary (Continued)

MSR Address	Type	Register Name	Reset Value	Reference
00001A03h	R/W	FPU Reserved MSR (FPU_RSVD_MSR)	00000000_00000000h	Page 202
00001A10h	R/W	FPU x87 Control Word MSR (FPU_CW_MSR)	00000000_00000040h	Page 203
00001A11h	R/W	FPU x87 Status Word MSR (FPU_SW_MSR)	00000000_00000000h	Page 203
00001A12h	R/W	FPU x87 Tag Word MSR (FPU_TW_MSR)	00000000_00000000h	Page 203
00001A13h	RO	FPU Busy MSR (FPU_BUSY_MSR)	00000000_00000000h	Page 204
00001A14h	RO	FPU Register Map MSR (FPU_MAP_MSR)	00000000_76543210h	Page 204
00001A40h	R/W	Mantissa of R0 MSR (FPU_MR0_MSR)	xxxxxxxx_xxxxxxxxxh	Page 205
00001A41h	R/W	Exponent of R0 MSR (FPU_ER0_MSR)	00000000_0000xxxxh	Page 206
00001A42h	R/W	Mantissa of R1 MSR (FPU_MR1_MSR)	xxxxxxxx_xxxxxxxxxh	Page 205
00001A43h	R/W	Exponent of R1 MSR (FPU_ER1_MSR)	00000000_0000xxxxh	Page 206
00001A44h	R/W	Mantissa of R2 MSR (FPU_MR2_MSR)	xxxxxxxx_xxxxxxxxxh	Page 205
00001A45h	R/W	Exponent of R2 MSR (FPU_ER2_MSR)	00000000_0000xxxxh	Page 206
00001A46h	R/W	Mantissa of R3 MSR (FPU_MR3_MSR)	xxxxxxxx_xxxxxxxxxh	Page 205
00001A47h	R/W	Exponent of R3 MSR (FPU_ER3_MSR)	00000000_0000xxxxh	Page 206
00001A48h	R/W	Mantissa of R4 MSR (FPU_MR4_MSR)	xxxxxxxx_xxxxxxxxxh	Page 205
00001A49h	R/W	Exponent of R4 MSR (FPU_ER4_MSR)	00000000_0000xxxxh	Page 206
00001A4Ah	R/W	Mantissa of R5 MSR (FPU_MR5_MSR)	xxxxxxxx_xxxxxxxxxh	Page 205
00001A4Bh	R/W	Exponent of R5 MSR (FPU_ER5_MSR)	00000000_0000xxxxh	Page 206
00001A4Ch	R/W	Mantissa of R6 MSR (FPU_MR6_MSR)	xxxxxxxx_xxxxxxxxxh	Page 205
00001A4Dh	R/W	Exponent of R6 MSR (FPU_ER6_MSR)	00000000_0000xxxxh	Page 206
00001A4Eh	R/W	Mantissa of R7 MSR (FPU_MR7_MSR)	xxxxxxxx_xxxxxxxxxh	Page 205
00001A4Fh	R/W	Exponent of R7 MSR (FPU_ER7_MSR)	00000000_0000xxxxh	Page 206
00001A50h	R/W	Mantissa of R8 MSR (FPU_MR8_MSR)	xxxxxxxx_xxxxxxxxxh	Page 205
00001A51h	R/W	Exponent of R8 MSR (FPU_ER8_MSR)	00000000_0000xxxxh	Page 206
00001A52h	R/W	Mantissa of R9 MSR (FPU_MR9_MSR)	xxxxxxxx_xxxxxxxxxh	Page 205
00001A53h	R/W	Exponent of R9 MSR (FPU_ER9_MSR)	00000000_0000xxxxh	Page 206
00001A54h	R/W	Mantissa of R10 MSR (FPU_MR10_MSR)	xxxxxxxx_xxxxxxxxxh	Page 205
00001A55h	R/W	Exponent of R10 MSR (FPU_ER10_MSR)	00000000_0000xxxxh	Page 206
00001A56h	R/W	Mantissa of R11 MSR (FPU_MR11_MSR)	xxxxxxxx_xxxxxxxxxh	Page 205
00001A57h	R/W	Exponent of R11 MSR (FPU_ER11_MSR)	00000000_0000xxxxh	Page 206
00001A58h	R/W	Mantissa of R12 MSR (FPU_MR12_MSR)	xxxxxxxx_xxxxxxxxxh	Page 205
00001A59h	R/W	Exponent of R12 MSR (FPU_ER12_MSR)	00000000_0000xxxxh	Page 206
00001A5Ah	R/W	Mantissa of R13 MSR (FPU_MR13_MSR)	xxxxxxxx_xxxxxxxxxh	Page 205
00001A5Bh	R/W	Exponent of R13 MSR (FPU_ER13_MSR)	00000000_0000xxxxh	Page 206
00001A5Ch	R/W	Mantissa of R14 MSR (FPU_MR14_MSR)	xxxxxxxx_xxxxxxxxxh	Page 205
00001A5Dh	R/W	Exponent of R14 MSR (FPU_ER14_MSR)	00000000_0000xxxxh	Page 206
00001A5Eh	R/W	Mantissa of R15 MSR (FPU_MR15_MSR)	xxxxxxxx_xxxxxxxxxh	Page 205
00001A5Fh	R/W	Exponent of R15 MSR (FPU_ER15_MSR)	00000000_0000xxxxh	Page 206
00001A60h-00001A6Fh	R/W	FPU Reserved MSRs (FPU_RSVD_MSR)	xxxxxxxx_xxxxxxxxxh	Page 207

Table 5-13. CPU Core Specific MSRs Summary (Continued)

MSR Address	Type	Register Name	Reset Value	Reference
00003000h	R/W	Standard Levels and Vendor ID String 1 (CPUID0_MSR)	68747541_00000001h	Page 207
00003001h	R/W	Vendor ID Strings 2 and 3 (CPUID1_MSR)	69746E65_444D4163h	Page 207
00003002h	R/W	Type/Family/Model/Step (CPUID2_MSR)	00000400_000005A2h	Page 207
00003003h	R/W	Feature Flags (CPUID3_MSR)	0088A93D_00000000h	Page 207
00003004h	WO	Reserved (CPUID4_MSR)	00000000_00000000h	Page 207
00003005h	WO	Reserved (CPUID5_MSR)	00000000_00000000h	Page 207
00003006h	R/W	Max Extended Levels 1 (CPUID6_MSR)	68747541_80000006h	Page 207
00003007h	R/W	Max Extended Levels 2 (CPUID7_MSR)	69746E65_444D4163h	Page 207
00003008h	R/W	Extended Type/Family/Model/Stepping (CPUID8_MSR)	00000000_000005A1h	Page 207
00003009h	R/W	Extended Feature Flags (CPUID9_MSR)	C0C0A13D_00000000h	Page 207
0000300Ah	R/W	CPU Marketing Name 1 (CPUIDA_MSR)	4D542865_646F6547h	Page 207
0000300Bh	R/W	CPU Marketing Name 2 (CPUIDB_MSR)	72676574_6E492029h	Page 207
0000300Ch	R/W	CPU Marketing Name 3 (CPUIDC_MSR)	6F725020_64657461h	Page 207
0000300Dh	R/W	CPU Marketing Name 4 (CPUIDD_MSR)	6220726F_73736563h	Page 207
0000300Eh	R/W	CPU Marketing Name 5 (CPUIDE_MSR)	43502044_4D412079h	Page 207
0000300Fh	R/W	CPU Marketing Name 6 (CPUIDF_MSR)	00000000_00000053h	Page 207
00003010h	R/W	L1 TLB Information (CPUID10_MSR)	FF10FF10_00000000h	Page 207
00003011h	R/W	L1 Cache Information (CPUID11_MSR)	40100120_40100120h	Page 207
00003012h	R/W	L2 TLB Information (CPUID12_MSR)	00002040_0000F004h	Page 207
00003013h	R/W	L2 Cache Information (CPUID13_MSR)	00000000_00804120h	Page 207

**5.5.1 Standard GeodeLink™ Device MSRs**

**5.5.1.1 GLD Capabilities MSR (GLD\_MSR\_CAP)**

MSR Address 00002000h  
 Type RO  
 Reset Value 00000000\_000864xxh

**GLD\_MSR\_CAP Register Map**

63	62	61	60	59	58	57	56	55	54	53	52	51	50	49	48	47	46	45	44	43	42	41	40	39	38	37	36	35	34	33	32
RSVD																															
31	30	29	28	27	26	25	24	23	22	21	20	19	18	17	16	15	14	13	12	11	10	9	8	7	6	5	4	3	2	1	0
RSVD								DEV_ID														REV_ID									

**GLD\_MSR\_CAP Bit Descriptions**

Bit	Name	Description
63:24	RSVD	<b>Reserved.</b> Reads as 0.
23:8	DEV_ID	<b>Device ID.</b> Identifies device (0864h).
7:0	REV_ID	<b>Revision ID.</b> Identifies device revision. See <i>AMD Geode™ LX Processors Specification Update</i> document for value.

**5.5.1.2 GLD Master Configuration MSR (GLD\_MSR\_CONFIG)**

MSR Address 00002001h  
 Type R/W  
 Reset Value 00000000\_00000320h

**GLD\_MSR\_CONFIG Register Map**

63	62	61	60	59	58	57	56	55	54	53	52	51	50	49	48	47	46	45	44	43	42	41	40	39	38	37	36	35	34	33	32
RSVD																															
31	30	29	28	27	26	25	24	23	22	21	20	19	18	17	16	15	14	13	12	11	10	9	8	7	6	5	4	3	2	1	0
RSVD																		RSVD					PRIO			RSVD	PID				

**GLD\_MSR\_CONFIG Bit Descriptions**

Bit	Name	Description
63:11	RSVD	<b>Reserved.</b> Write as read.
10:7	RSVD	<b>Reserved.</b> (Default = 3)
6:4	PRI0	<b>Priority Level.</b> Priority value used for CPU Core GLIU requests. (Default = 2)
3	RSVD	<b>Reserved.</b> Write as read.
2:0	PID	<b>Priority ID Value.</b> Priority ID value used for CPU Core GLIU requests. Always write to 0. (Default = 0)

**5.5.1.3 GLD SMI MSR (GLD\_MSR\_SMI)**

MSR Address 00002002h  
Type R/W  
Reset Value 00000000\_00000000h

This register is not used in the CPU Core module.

**5.5.1.4 GLD Error MSR (GLD\_MSR\_ERROR)**

MSR Address 00002003h  
Type R/W  
Reset Value 00000000\_00000000h

This register is not used in the CPU Core module.

**5.5.1.5 GLD Power Management MSR (GLD\_MSR\_PM)**

MSR Address 00002004h  
Type R/W  
Reset Value 00000000\_00000000h

This register is not used in the CPU Core module.

**5.5.1.6 GLD Diagnostic Bus Control MSR (GLD\_MSR\_DIAG)**

MSR Address 00002005h  
Type R/W  
Reset Value 00000000\_00000000h

This register is reserved for internal use by AMD and should not be written to.

## 5.5.2 CPU Core Specific MSRs

### 5.5.2.1 Time Stamp Counter MSR (TSC\_MSR)

MSR Address 00000010h  
 Type R/W  
 Reset Value 00000000\_00000000h

**TSC\_MSR Register Map**

63	62	61	60	59	58	57	56	55	54	53	52	51	50	49	48	47	46	45	44	43	42	41	40	39	38	37	36	35	34	33	32
TSC (High DWORD)																															
31	30	29	28	27	26	25	24	23	22	21	20	19	18	17	16	15	14	13	12	11	10	9	8	7	6	5	4	3	2	1	0
TSC (Low DWORD)																															

**TSC\_MSR Bit Descriptions**

Bit	Name	Description
63:0	TSC	<p><b>Time Stamp Counter.</b> This register is the 64-bit time stamp counter, also readable via the RDTSC instruction.</p> <p>Bus Controller Configuration 0 Register (MSR 00001900h) contains configuration bits that determine if TSC counts during SMM, DMM, or Suspend modes.</p> <p>Writes to this register clears the upper DWORD to 0. The lower DWORD is written normally.</p>

### 5.5.2.2 Performance Event Counter 0 MSR (PERF\_CNT0\_MSR)

MSR Address 000000C1h  
 Type R/W  
 Reset Value 00000000\_00000000h

**PERF\_CNT0\_MSR Register Map**

63	62	61	60	59	58	57	56	55	54	53	52	51	50	49	48	47	46	45	44	43	42	41	40	39	38	37	36	35	34	33	32
RSVD																								PERF_CNT0 (High Byte)							
31	30	29	28	27	26	25	24	23	22	21	20	19	18	17	16	15	14	13	12	11	10	9	8	7	6	5	4	3	2	1	0
PERF_CNT0 (Low DWORD)																															

**PERF\_CNT0\_MSR Bit Descriptions**

Bit	Name	Description
63:40	RSVD	<b>Reserved.</b> Write as read.
39:0	PERF_CNT0	<p><b>Performance Event Counter 0.</b> This register is a 40-bit event counter used to count events or conditions inside of the CPU Core. This counter is controlled by Performance Event Counter 0 Select MSR (MSR 00000186h).</p>

**5.5.2.3 Performance Event Counter 1 MSR (PERF\_CNT1\_MSR)**

MSR Address 000000C2h  
 Type R/W  
 Reset Value 00000000\_00000000h

**PERF\_CNT1\_MSR Register Map**

63	62	61	60	59	58	57	56	55	54	53	52	51	50	49	48	47	46	45	44	43	42	41	40	39	38	37	36	35	34	33	32
RSVD																								PERF_CNT1 (High Byte)							
31	30	29	28	27	26	25	24	23	22	21	20	19	18	17	16	15	14	13	12	11	10	9	8	7	6	5	4	3	2	1	0
PERF_CNT1 (Low DWORD)																															

**PERF\_CNT1\_MSR Bit Descriptions**

Bit	Name	Description
63:40	RSVD	<b>Reserved.</b> Write as read.
39:0	PERF_CNT1	<b>Performance Event Counter 1.</b> This register is a 40-bit event counter used to count events or conditions inside the CPU Core. This counter is controlled by Performance Event Counter 1 Select MSR (MSR 00000187h).

#### 5.5.2.4 SYSENTER/SYSEXIT Code Segment Selector MSR (SYS\_CS\_MSR)

MSR Address 00000174h  
 Type R/W  
 Reset Value 00000000\_C09B0000h

SYS\_CS\_MSR is used by the SYSENTER instruction (fast system call) as the selector of the most privileged code segment. SYS\_CS plus 8 is used by SYSENTER as the selector of the most privileged stack segment. SYS\_CS plus 16 is used by SYSEXIT as the selector of the least privileged code segment. SYS\_CS plus 24 is used by SYSEXIT as the selector of the least privileged stack segment.

#### SYS\_CS\_MSR Register Map

63	62	61	60	59	58	57	56	55	54	53	52	51	50	49	48	47	46	45	44	43	42	41	40	39	38	37	36	35	34	33	32
RSVD																															
31	30	29	28	27	26	25	24	23	22	21	20	19	18	17	16	15	14	13	12	11	10	9	8	7	6	5	4	3	2	1	0
G	D	RSVD						P	DPL	S	X	C	R	A	CS_SEL													TI	RPL		

#### SYS\_CS\_MSR Bit Descriptions

Bit	Name	Description
63:32	RSVD	<b>Reserved.</b>
31	G (RO)	<b>Granularity (Read Only).</b> Code segment limit granularity is 4 KB. (Default = 1)
30	D (RO)	<b>Default (Read Only).</b> Code segment default size is 32 bits. (Default = 1)
29:24	RSVD (RO)	<b>Reserved (Read Only).</b>
23	P (RO)	<b>Present (Read Only).</b> Code segment descriptor is present. (Default = 1)
22:21	DPL (RO)	<b>Descriptor Privilege Level (Read Only).</b> Code segment descriptor privilege level. (Default = 11)
20	S (RO)	<b>Segment (Read Only).</b> Code segment is not a system segment. (Default = 1)
19	X (RO)	<b>Executable (Read Only).</b> Code segment is executable. (Default = 1)
18	C (RO)	<b>Conforming (Read Only).</b> Code segment is conforming. (Default = 0)
17	R (RO)	<b>Readable (Read Only).</b> Code segment is readable. (Default = 1)
16	A (RO)	<b>Accessed (Read Only).</b> Code segment was accessed. (Default = 1)
15:3	CS_SEL	<b>Code Segment Selector.</b> (Default = 0)
2	TI	<b>Descriptor Table Indicator.</b> (Default = 0)
1:0	RPL (RO)	<b>Requestor Privilege Level (Read Only).</b> (Default = 0)



**5.5.2.5 SYSENTER/SYSEXIT Stack Pointer MSR (SYS\_SP\_MSR)**

MSR Address 00000175h  
 Type R/W  
 Reset Value 00000000\_00000000h

SYS\_SP MSR is used by the SYSENTER instruction (fast system call) as the most privileged stack pointer.

**SYS\_SP\_MSR Register Map**

63	62	61	60	59	58	57	56	55	54	53	52	51	50	49	48	47	46	45	44	43	42	41	40	39	38	37	36	35	34	33	32
RSVD																															
31	30	29	28	27	26	25	24	23	22	21	20	19	18	17	16	15	14	13	12	11	10	9	8	7	6	5	4	3	2	1	0
ESP																															

**SYS\_SP\_MSR Bit Descriptions**

Bit	Name	Description
63:32	RSVD	<b>Reserved.</b>
31:0	ESP	<b>Enter Stack Pointer.</b> Stack pointer to be used after SYSENTER in most privileged code. (Default = 0)

**5.5.2.6 SYSENTER/SYSEXIT Instruction Pointer MSR (SYS\_IP\_MSR)**

MSR Address 00000176h  
 Type R/W  
 Reset Value 00000000\_00000000h

SYS\_IP MSR is used by the SYSENTER instruction (fast system call) as the offset into the most privileged code segment.

**SYS\_IP\_MSR Register Map**

63	62	61	60	59	58	57	56	55	54	53	52	51	50	49	48	47	46	45	44	43	42	41	40	39	38	37	36	35	34	33	32
RSVD																															
31	30	29	28	27	26	25	24	23	22	21	20	19	18	17	16	15	14	13	12	11	10	9	8	7	6	5	4	3	2	1	0
EIP																															

**SYS\_IP\_MSR Bit Descriptions**

Bit	Name	Description
63:32	RSVD	<b>Reserved.</b>
31:0	EIP	<b>Enter Instruction Pointer.</b> Offset into the most privileged code segment. (Default = 0)

**5.5.2.7 Performance Event Counter 0 Select MSR (PERF\_SELO\_MSR)**

MSR Address 00000186h  
 Type R/W  
 Reset Value 00000000\_00000000h

**PERF\_SELO\_MSR Register Map**

63	62	61	60	59	58	57	56	55	54	53	52	51	50	49	48	47	46	45	44	43	42	41	40	39	38	37	36	35	34	33	32	
RSVD																																
31	30	29	28	27	26	25	24	23	22	21	20	19	18	17	16	15	14	13	12	11	10	9	8	7	6	5	4	3	2	1	0	
RSVD									PC_EN	RSVD							PC0_UMASK						PC0_EVENT									

**PERF\_SELO\_MSR Bit Descriptions**

Bit	Name	Description
63:23	RSVD	<b>Reserved.</b> Write as read.
22	PC_EN	<b>Performance Event Counters 0 and 1 Enable.</b> 0: Disable counters. 1: Enable counters.
21:16	RSVD	<b>Reserved.</b> Write as read.
15:8	PC0_UMASK	<b>Performance Event Counter 0 Unit Mask.</b> Selects sub-events. 00h: All sub-events counted.
7:0	PC0_EVENT	<b>Performance Event Counter 0 Event Select Value.</b> See individual module chapters for performance event selections.

**5.5.2.8 Performance Event Counter 1 Select MSR (PERF\_SEL1\_MSR)**

MSR Address 00000187h  
 Type R/W  
 Reset Value 00000000\_00000000h

**PERF\_SEL1\_MSR Register Map**

63	62	61	60	59	58	57	56	55	54	53	52	51	50	49	48	47	46	45	44	43	42	41	40	39	38	37	36	35	34	33	32
RSVD																															
31	30	29	28	27	26	25	24	23	22	21	20	19	18	17	16	15	14	13	12	11	10	9	8	7	6	5	4	3	2	1	0
RSVD																PC1_UMASK						PC1_EVENT									

**PERF\_SEL1\_MSR Bit Descriptions**

Bit	Name	Description
63:16	RSVD	<b>Reserved.</b> Write as read.
15:8	PC1_UMASK	<b>Performance Event Counter 1 Unit Mask.</b> Selects sub-events. 00h: All sub-events counted.
7:0	PC1_EVENT	<b>Performance Event Counter 1 Event Select Value.</b> See individual module chapters for performance event selections.

**5.5.2.9 Instruction Fetch Configuration MSR (IF\_CONFIG\_MSR)**

MSR Address 00001100h  
 Type R/W  
 Reset Value 00000000\_00005051h

IF\_CONFIG\_MSR controls the operation of the Instruction Fetch (IF). The Level-0 COF cache (Change of Flow (COF) cache), L1 COF cache, return stack, and power saving mode may be turned on or off. The WRMSR instruction can access IF\_CONFIG MSR at any time. Devices external to the CPU should issue writes to IF\_CONFIG MSR only if the CPU is suspended or stalled.

**IF\_CONFIG\_MSR Register Map**

63	62	61	60	59	58	57	56	55	54	53	52	51	50	49	48	47	46	45	44	43	42	41	40	39	38	37	36	35	34	33	32
RSVD																BETD	BIVD	LSNPD	PSNPD	RSVD				BSP			RSVD	W_DIS			
31	30	29	28	27	26	25	24	23	22	21	20	19	18	17	16	15	14	13	12	11	10	9	8	7	6	5	4	3	2	1	0
RSVD			IL_NS	RSVD			CC_SER	RSVD			RQ_SER	RSVD			IL_SER	RSVD	IL_MFLSH	RSVD	CC_LO	RSVD	DMM_DIS	RSVD	CC_PS	RSVD	STRONG	RSVD	RS	RSVD	CC_INVL	RSVD	CC_L1

**IF\_CONFIG\_MSR Bit Descriptions**

Bit	Name	Description
63:48	RSVD	<b>Reserved.</b>
47	BETD	<b>Branch Tree Messaging (BTM) Exception Type.</b> Allow the BTM stream to contain exception type records. 0: Enable. (Default) 1: Disable.
46	BIVD	<b>Branch Tree Messaging Interrupt Vector.</b> Allow the BTM stream to contain interrupt vector records. 0: Enable. (Default) 1: Disable.
45	LSNPD	<b>Linear Snooping.</b> 0: Enable. (Default) 1: Disable.
44	PSNPD	<b>Physical Snooping.</b> 0: Enable. (Default) 1: Disable.
43:41	RSVD	<b>Reserved.</b>
40:37	BSP	<b>Branch Tree Messaging Sync Period.</b> Specifies the maximum period between BTM synchronization records. If BSP is non-zero, the IF will insert a synchronization record into the BTM stream whenever it sees a series of 32*BSP non-synchronization records. (Default = 0)
36	RSVD	<b>Reserved.</b>
35:32	W_DIS	<b>Branch Target Buffer (BTB) Way.</b> Each bit is used to disable one Way of the BTB. Bit 32 = Way 0, bit 33 = Way 1, bit 34 = Way 2, and bit 35 = Way 3. 0: Enable Way. (Default) 1: Disable Way.
31:29	RSVD	<b>Reserved.</b>

## IF\_CONFIG\_MSR Bit Descriptions (Continued)

Bit	Name	Description
28	II_NS	<b>Instruction Pipeline (IP) Empty Mode.</b> 0: IM Interface may make requests to Instruction Memory (IM) when the IP is not empty. (Default) 1: IM Interface only makes requests to IM after the IP is empty. <b>Note:</b> Enabling this mode reduces performance.
27:25	RSVD	<b>Reserved.</b>
24	CC_SER	<b>COF Cache Serialization.</b> 0: Allow more than one outstanding request in COF cache. (Default) 1: Allow only one request in the COF cache. <b>Note:</b> Enabling COF cache serialization may reduce performance.
23:21	RSVD	<b>Reserved.</b>
20	RQ_SER	<b>Request Queue Serialization.</b> 0: Allow more than one request in the Request Queue. (Default) 1: Only one request is allowed in the Request Queue. <b>Note:</b> Enabling RQ serialization reduces performance.
19:17	RSVD	<b>Reserved.</b>
16	II_SER	<b>Instruction Memory Request Serialization.</b> 0: IM requests are not serialized. (Default) 1: IM Interface waits until IM responds to a request before IM Interface issues the next request. <b>Note:</b> Enabling IM Interface serialization reduces performance.
15	RSVD	<b>Reserved.</b>
14	II_IMFLSH	<b>Instruction Memory Flush.</b> 0: IF never issues flush requests to IM. 1: IF may issue flush requests to IM. (Default) <b>Note:</b> Enabling IM flushing usually increases performance.
13	RSVD	<b>Reserved.</b>
12	CC_L0	<b>Level-0 COF Cache.</b> 0: Disable. 1: Enable. (Default) <b>Note:</b> Enabling the L0 COF cache increases performance. Unless CC_L1 is enabled (bit 0 = 1), then CC_L0 has no effect.
11	RSVD	<b>Reserved.</b>
10	DMM_DIS	<b>Debug Management Mode (DMM).</b> 0: The COF cache and return stack is neither used nor updated during DMM. (Default) 1: The COF cache and return stack may be used and updated during DMM. <b>Note:</b> Disabling the COF cache and return stack during DMM may reduce performance but make debug easier.
9	RSVD	<b>Reserved.</b>
8	CC_PS	<b>Power Saving Mode.</b> 0: Disable. (Default) 1: Enable. <b>Note:</b> CC_L1 must be disabled (bit 0 = 0) to enable power saving.
7	RSVD	<b>Reserved.</b>

## IF\_CONFIG\_MSR Bit Descriptions (Continued)

Bit	Name	Description
6	STRONG	<b>Strong Prediction.</b> Allow the IF to make strong predictions. 0: Disable. 1: Enable. (Default) <b>Note:</b> Enabling strong predictions may improve performance.
5	RSVD	<b>Reserved.</b>
4	RS	<b>Return Stack.</b> 0: Disable. 1: Enable. (Default) <b>Note:</b> Enabling the return stack increases performance unless CC_L1 is enabled (bit 0 = 1), then the return stack has no effect.
3	RSVD	<b>Reserved.</b>
2	CC_INVL	<b>COF Cache Invalidation.</b> 0: Translation Look-aside Buffer (TLB) invalidations do not invalidate the COF cache. (Default) 1: Whenever the TLB is invalidated, the COF cache is also invalidated. <b>Note:</b> Invalidating the COF cache whenever the TLB is invalidated may reduce performance.
1	RSVD	<b>Reserved.</b>
0	CC_L1	<b>Level-1 COF Cache.</b> 0: Disable. 1: Enable. (Default) <b>Note:</b> Enabling the L1 COF cache increases performance.

**5.5.2.10 IF Invalidate MSR (IF\_INVALIDATE\_MSR)**

MSR Address 00001102h  
 Type W  
 Reset Value 00000000\_00000000h

IF\_INVALIDATE MSR may be used to invalidate the contents of the Tag RAMs (Level-1 COF cache), Level-0 COF cache, and the return stack. Devices external to the CPU should issue writes to IF\_INVALIDATE\_MSR only if the CPU is suspended or stalled.

**IF\_INVALIDATE\_MSR Register Map**

63	62	61	60	59	58	57	56	55	54	53	52	51	50	49	48	47	46	45	44	43	42	41	40	39	38	37	36	35	34	33	32
RSVD																															
31	30	29	28	27	26	25	24	23	22	21	20	19	18	17	16	15	14	13	12	11	10	9	8	7	6	5	4	3	2	1	0
RSVD																														RS	CC

**IF\_INVALIDATE\_MSR Bit Descriptions**

Bit	Name	Description
63:2	RSVD	<b>Reserved.</b>
1	RS	<b>Invalidate Return Stack.</b> 0: Do not alter the return stack. (Default) 1: Empty the return stack.
0	CC	<b>Invalidate L0 and L1 COF Cache.</b> 0: Do not alter the COF cache. (Default) 1: Empty the COF cache.

**5.5.2.11 IF Test Address MSR (IF\_TEST\_ADDR\_MSR)**

MSR Address 00001108h  
 Type R/W  
 Reset Value 00000000\_00000000h

IF\_TEST\_ADDR\_MSR is used to indirectly address the IF state elements, while IF\_TEST\_DATA\_MSR (MSR 0000109h) is used to read/write the elements. The format of the data written to, or read from IF\_TEST\_DATA\_MSR depends on the value in IF\_TEST\_ADDR\_MSR.

**IF\_TEST\_ADDR\_MSR Register Map**

63	62	61	60	59	58	57	56	55	54	53	52	51	50	49	48	47	46	45	44	43	42	41	40	39	38	37	36	35	34	33	32
RSVD																															
31	30	29	28	27	26	25	24	23	22	21	20	19	18	17	16	15	14	13	12	11	10	9	8	7	6	5	4	3	2	1	0
RSVD																BLOCK						INDEX									

**IF\_TEST\_ADDR\_MSR Bit Descriptions**

Bit	Name	Description
63:13	RSVD	<b>Reserved.</b>

**IF\_TEST\_ADDR\_MSR Bit Descriptions (Continued)**

Bit	Name	Description
12:8	BLOCK	<p><b>Block Identifier.</b></p> <p>00h: Target RAM 0 (Way 0). (Default)                      01h: Target RAM 1 (Way 0).                      02h: Target RAM 2 (Way 0).                      03h: Target RAM 3 (Way 0).                      04h: Target RAM 4 (Way 1).                      05h: Target RAM 5 (Way 1).                      06h: Target RAM 6 (Way 1).                      07h: Target RAM 7 (Way 1).                      08h: Target RAM 8 (Way 2).                      09h: Target RAM 9 (Way 2).                      0Ah: Target RAM 10 (Way 2).                      0Bh: Target RAM 11 (Way 2).                      0Ch: Target RAM 12 (Way 3).                      0Dh: Target RAM 13 (Way 3).                      0Eh: Target RAM 14 (Way 3).                      0Fh: Target RAM 15 (Way 3).                      10h: Tag RAM 0 (Way 0).                      11h: Tag RAM 1 (Way 1).                      12h: Tag RAM 2 (Way 2).                      13h: Tag RAM 3 (Way 3).                      14h: L0 COF cache.                      15h: Return stack.</p>
7:0	INDEX	<p><b>Block Index.</b> (Default = 00h)</p> <p>When accessing a Tag RAM or a Target RAM, the index is the address of the RAM location (0-255).</p> <p>When accessing the L0 COF cache, indexes 0-1 refer to the 2 tag entries, 4-5 refer to the 2 source addresses, 8-9 refer to the 2 target addresses, and 12-13 refer to the 2 return addresses.</p> <p>When accessing the return stack, indexes 0-7 refer to the 8 non-speculative return addresses, indexes 8-15 refer to the IF speculative return addresses, and address 16 refers to the valid bits, indexes 17-24 refer to the ID speculative return addresses.</p>

**5.5.2.12 IF Test Data MSR (IF\_TEST\_DATA\_MSR)**

MSR Address 00001109h  
 Type R/W  
 Reset Value 00000000\_xxxxxxxh

**IF\_TEST\_DATA\_MSR Register Map for Target RAMs**

63	62	61	60	59	58	57	56	55	54	53	52	51	50	49	48	47	46	45	44	43	42	41	40	39	38	37	36	35	34	33	32
RSVD																															
31	30	29	28	27	26	25	24	23	22	21	20	19	18	17	16	15	14	13	12	11	10	9	8	7	6	5	4	3	2	1	0
TGT																															

**IF\_TEST\_DATA\_MSR Bit Descriptions for Target RAMs**

Bit	Name	Description
63:32	RSVD	<b>Reserved.</b>
31:0	TGT	<b>COF Target.</b>

## IF\_TEST\_DATA\_MSR Register Map for Tag RAMs

63	62	61	60	59	58	57	56	55	54	53	52	51	50	49	48	47	46	45	44	43	42	41	40	39	38	37	36	35	34	33	32
RSVD																															
31	30	29	28	27	26	25	24	23	22	21	20	19	18	17	16	15	14	13	12	11	10	9	8	7	6	5	4	3	2	1	0
V	LIP										RSVD	STRENGTH			TYPE				END												

## IF\_TEST\_DATA\_MSR Bit Descriptions for Tag RAMs

Bit	Name	Description
63:32	RSVD	<b>Reserved.</b>
31	V	<b>Tag is Valid.</b> (Default = 0)
30:22	LIP	<b>Linear Address Bits [19:11].</b>
21:20	RSVD	<b>Reserved.</b>
19:16	STRENGTH	<b>Prediction Strength.</b> Bit 19 = STRENGTH3, bit 18 = STRENGTH2, bit 17 = STRENGTH1, and bit 16 = STRENGTH0. 0: Weakly predicted. 1: Strongly predicted.
15:8	TYPE	<b>COF Type.</b> Bits [15:14] = TYPE3, bits [13:12] = TYPE2, bits [11:10] = TYPE1, and bits [9:8] = TYPE0.
7:0	END	<b>Predicted Taken COF End Markers.</b>

## IF\_TEST\_DATA\_MSR Register Map for Level-0 COF Cache Tag

63	62	61	60	59	58	57	56	55	54	53	52	51	50	49	48	47	46	45	44	43	42	41	40	39	38	37	36	35	34	33	32
RSVD																															
31	30	29	28	27	26	25	24	23	22	21	20	19	18	17	16	15	14	13	12	11	10	9	8	7	6	5	4	3	2	1	0
RSVD										PNTKN	RSVD			VLD	LEN			RSVD			PTKN	RSVD	TYPE	RSVD			LRU				

## IF\_TEST\_DATA\_MSR Bit Descriptions for Level-0 COF Cache Tag

Bit	Name	Description
63:21	RSVD	<b>Reserved.</b>
20	PNTKN	<b>Predicted Not Taken.</b> Entry ends with a predicted not-taken change of flow.
19:17	RSVD	<b>Reserved.</b>
16	VLD	<b>Valid.</b> If an entry is valid, then all the tag information as well as the entry's address and target must also be valid. (Default = 0)
15:12	LEN	<b>Number of Bytes.</b> Number of bytes from address to either end of QWORD or end of predicted taken change of flow (0-8).
11:9	RSVD	<b>Reserved.</b>
8	PTKEN	<b>Predicted Taken.</b> Entry ends with a predicted taken change of flow.
7:6	RSVD	<b>Reserved.</b>
5:4	TYPE	<b>Change of Flow Type.</b>
3:1	RSVD	<b>Reserved.</b>
0	LRU	<b>Next Entry.</b> Indicates that entry is the next entry to be written. Exactly one of the four entries should have this bit set.



**IF\_TEST\_DATA\_MSR Register Map for Level-0 COF Cache Address**

63	62	61	60	59	58	57	56	55	54	53	52	51	50	49	48	47	46	45	44	43	42	41	40	39	38	37	36	35	34	33	32
RSVD																															
31	30	29	28	27	26	25	24	23	22	21	20	19	18	17	16	15	14	13	12	11	10	9	8	7	6	5	4	3	2	1	0
ADDR[31:0]																															

**IF\_TEST\_DATA\_MSR Bit Descriptions for Level-0 COF Cache Address**

Bit	Name	Description
63:32	RSVD	<b>Reserved.</b>
31:0	ADDR[31:0]	<b>Address Bits [31:0].</b> Linear address for which the entry contains data.

**IF\_TEST\_DATA\_MSR Register Map for Level-0 COF Cache Target**

63	62	61	60	59	58	57	56	55	54	53	52	51	50	49	48	47	46	45	44	43	42	41	40	39	38	37	36	35	34	33	32
RSVD																															
31	30	29	28	27	26	25	24	23	22	21	20	19	18	17	16	15	14	13	12	11	10	9	8	7	6	5	4	3	2	1	0
TARGET[31:0]																															

**IF\_TEST\_DATA\_MSR Bit Descriptions for Level-0 COF Cache Target**

Bit	Name	Description
63:32	RSVD	<b>Reserved.</b>
31:0	TARGET[31:0]	<b>Target Bits [31:0].</b> If an entry is valid and contains a predicted taken change of flow, then this is the predicted target for the change of flow.

**IF\_TEST\_DATA\_MSR Register Map for Return Stack Addresses**

63	62	61	60	59	58	57	56	55	54	53	52	51	50	49	48	47	46	45	44	43	42	41	40	39	38	37	36	35	34	33	32
RSVD																															
31	30	29	28	27	26	25	24	23	22	21	20	19	18	17	16	15	14	13	12	11	10	9	8	7	6	5	4	3	2	1	0
ADDR[31:0]																															

**IF\_TEST\_DATA\_MSR Bit Descriptions for Return Stack Addresses**

Bit	Name	Description
63:32	RSVD	<b>Reserved.</b>
31:0	ADDR[31:0]	<b>Address Bits [31:0].</b> Linear address to which a Return instruction should return.

**IF\_TEST\_DATA\_MSR Register Map for Return Stack Valid**

63	62	61	60	59	58	57	56	55	54	53	52	51	50	49	48	47	46	45	44	43	42	41	40	39	38	37	36	35	34	33	32
RSVD																															
31	30	29	28	27	26	25	24	23	22	21	20	19	18	17	16	15	14	13	12	11	10	9	8	7	6	5	4	3	2	1	0
RSVD								ID_SPEC_VLD								IF_SPEC_VLD[7:0]								NONSPEC_VLD[7:0]							

**IF\_TEST\_DATA\_MSR Bit Descriptions for Return Stack Valid**

Bit	Name	Description
63:24	RSVD	<b>Reserved.</b>
23:16	ID_SPEC_VLD	<b>Valid Instruction Decode Speculative.</b> ID speculative return stack entries that are valid. The least significant entry is the next to be popped from the stack. (Default = 0)
15:8	IF_SPEC_VLD	<b>Valid Instruction Fetch Speculative.</b> IF speculative return stack entries that are valid. The least significant entry is the next to be popped from the stack. (Default = 0)
7:0	NONSPEC_VLD	<b>Valid Non-Speculative.</b> Non-speculative return stack entries that are valid. The least significant entry is the next to be popped from the stack. (Default = 0)

**5.5.2.13 IF Sequential Count MRS (IF\_SEQCOUNT\_MSR)**

MSR Address	00001110h
Type	RO
Reset Value	00000000_00000000h

IF\_SEQCOUNT MSR is a read only MSR containing the number of sequential instructions executed since the last change of flow. This is useful when the CPU is halted, since it helps determine the instructions executed since the last record of the BTM stream.

**IF\_SEQCOUNT\_MSR Register Map**

63	62	61	60	59	58	57	56	55	54	53	52	51	50	49	48	47	46	45	44	43	42	41	40	39	38	37	36	35	34	33	32
RSVD																															
31	30	29	28	27	26	25	24	23	22	21	20	19	18	17	16	15	14	13	12	11	10	9	8	7	6	5	4	3	2	1	0
RSVD																												SEQCOUNT			

**IF\_SEQCOUNT\_MSR Bit Descriptions**

Bit	Name	Description
63:5	RSVD	<b>Reserved.</b>
4:0	SEQCOUNT	<b>Sequential Count.</b> Number of sequential instructions executed since the last change of flow.

**5.5.2.14 IF Built-In Self-Test MSR (IF\_BIST\_MSR)**

MSR Address 00001140h  
 Type RO  
 Reset Value 00000000\_00000000h

IF\_BIST\_MSR may be used to run built-in self-test (BIST) on the IF Tag and Target RAMs, and to get an indication of whether the BIST run passed or failed. There are separate BIST controllers for the Tag RAM and for the Target RAMs. A MSR read of IF\_BIST\_MSR causes BIST to be run.

IF\_BIST\_MSR can only be run when the level-1 COF cache, the level-0 COF cache, and the return stack is disabled in the IF\_CONFIG MSR. If the COF cache is enabled, reading IF\_BIST\_MSR does not cause BIST to be run, and returns zero.

After BIST has been run by reading IF\_BIST\_MSR, the contents of the IF Tag RAMs is invalidated (cleared).

**IF\_BIST\_MSR Register Map**

63	62	61	60	59	58	57	56	55	54	53	52	51	50	49	48	47	46	45	44	43	42	41	40	39	38	37	36	35	34	33	32
RSVD																															
31	30	29	28	27	26	25	24	23	22	21	20	19	18	17	16	15	14	13	12	11	10	9	8	7	6	5	4	3	2	1	0
RSVD																														TGT_PASS	TAG_PASS

**IF\_BIST\_MSR Bit Descriptions**

Bit	Name	Description
63:2	RSVD	<b>Reserved.</b>
1	TGT_PASS	<b>Target RAM BIST Status.</b> 0: Target RAM BIST did not pass. (Default) 1: Target RAM BIST passed.
0	TAG_PASS	<b>Tag RAM BIST Status.</b> 0: Tag RAM BIST did not pass. (Default) 1: Tar RAM BIST passed.

**5.5.2.15 Exception Unit (XC) Configuration MSR (XC\_CONFIG\_MSR)**

MSR Address 00001210h  
 Type R/W  
 Reset Value 00000000\_00000000h

XC\_CONFIG\_MSR allows the processor to be configured so that when the processor is in its HALT state, it can request that its clocks be turned off. It also allows the processor to be configured so that the processor is suspended when a PAUSE instruction is executed.

**XC\_CONFIG\_MSR Register Map**

63	62	61	60	59	58	57	56	55	54	53	52	51	50	49	48	47	46	45	44	43	42	41	40	39	38	37	36	35	34	33	32
RSVD																															
31	30	29	28	27	26	25	24	23	22	21	20	19	18	17	16	15	14	13	12	11	10	9	8	7	6	5	4	3	2	1	0
RSVD																														SUSPONPAUSE	SUSPONHLT

**XC\_CONFIG\_MSR Bit Descriptions**

Bit	Name	Description
63:2	RSVD	<b>Reserved.</b>
1	SUSPONPAUSE	<b>Suspend on Pause.</b> When set, if a pause instruction is executed, the processor is suspended for the number of clocks specified in the PAUSEDLY field of BC_CONFIG0_MSR (MSR 00001900h[27:24]). (Default = 0)
0	SUSPONHLT	<b>Suspend on Halt.</b> When set, if the processor is halted, then it requests that its clocks be turned off. (Default = 0)

**5.5.2.16 XC Mode MSR (XC\_MODE\_MSR)**

MSR Address 00001211h  
 Type R/W  
 Reset Value 00000000\_00000000h

XC\_MODE\_MSR contains information about the current status of the processor.

**XC\_MODE\_MSR Register Map**

63	62	61	60	59	58	57	56	55	54	53	52	51	50	49	48	47	46	45	44	43	42	41	40	39	38	37	36	35	34	33	32
RSVD																															
31	30	29	28	27	26	25	24	23	22	21	20	19	18	17	16	15	14	13	12	11	10	9	8	7	6	5	4	3	2	1	0
RSVD																DM_AC_STALL	FP_STALL	FP_ERROR	FP_BUSY	IP_BUSY	DM_BUSY	IF_BUSY	DM_EX_DELAY	IQ_EMPTY	WAIT_FPINTR	FLUSHING	HALTED	SUSPENDED	NMI_ACTIVE	DMM_ACTIVE	SMM_ACTIVE

**XC\_MODE\_MSR Bit Descriptions**

Bit	Name	Description
63:16	RSVD (RO)	<b>Reserved (Read Only).</b>
15	DM_AC_STALL (RO)	<b>Data Memory Subsystem Stall Address Calculation Unit (Read Only).</b> DM wants no more requests from AC.
14	FP_STALL (RO)	<b>Floating Point Stall (Read Only).</b> FP is stalling the pipeline.
13	FP_ERROR (RO)	<b>Floating Point Error (Read Only).</b> FP is reporting an error.
12	FP_BUSY (RO)	<b>Floating Point Busy (Read Only).</b> FP is reporting that it is not idle.
11	IP_BUSY (RO)	<b>Instruction Pipeline Busy (Read Only).</b> IP is reporting that it is not idle.
10	DM_BUSY (RO)	<b>Data Memory Subsystem Busy (Read Only).</b> DM is reporting that it is not idle.
9	IF_BUSY (RO)	<b>Instruction Fetch Busy (Ready Only).</b> IF is reporting that it is not idle.
8	DM_EX_DELAY (RO)	<b>Data Memory Subsystem Execution Delay (Read Only).</b> Pipeline is waiting for DM to provide instruction data.
7	IQ_EMPTY (RO)	<b>Instruction Queue Empty (Read Only).</b> Instruction Queue is empty.
6	WAIT_FPINTR (RO)	<b>Wait for Floating Point Interrupt (Read Only).</b> Processor is waiting for an external maskable interrupt due to a FP error (CR0 NE bit is set, See Table 5-10 "CR0 Bit Descriptions" on page 96). (Default = 0)
5	FLUSHING (RO)	<b>Flushing (Read Only).</b> Processor is flushing the pipeline while waiting for DM to empty.
4	HALTED (RO)	<b>Halted (Read Only).</b> Processor is halted. (Default = 0)
3	SUSPENDED (RO)	<b>Suspended (Read Only).</b> Processor is suspended. (Default = 0)
2	NMI_ACTIVE	<b>Non-Maskable Interrupt Active.</b> Processor is in a NMI handler. (Default = 0)
1	DMM_ACTIVE	<b>Debug Management Mode.</b> Processor is in debug management mode. (Default = 0)
0	SMM_ACTIVE	<b>System Management Mode.</b> Processor is in system management mode. (Default = 0)

**5.5.2.17 XC History MSR (XC\_HIST\_MSR)**

MSR Address 00001212h  
 Type RO  
 Reset Value 00000000\_00000000h

**XC\_HIST\_MSR Register Map**

63	62	61	60	59	58	57	56	55	54	53	52	51	50	49	48	47	46	45	44	43	42	41	40	39	38	37	36	35	34	33	32
RSVD		TYPE11				TYPE10				TYPE9				TYPE8				TYPE7				TYPE6									
31	30	29	28	27	26	25	24	23	22	21	20	19	18	17	16	15	14	13	12	11	10	9	8	7	6	5	4	3	2	1	0
RSVD		TYPE5				TYPE4				TYPE3				TYPE2				TYPE1				TYPE0									

**XC\_HIST\_MSR Bit Descriptions**

Bit	Name	Description (Note 1)
63:62	RSVD	Reserved.
61:57	TYPE11	Exception Type 11.
56:52	TYPE10	Exception Type 10.
51:47	TYPE9	Exception Type 9.
46:42	TYPE8	Exception Type 8.
41:37	TYPE7	Exception Type 7.
36:32	TYPE6	Exception Type 6.
31:30	RSVD	Reserved.
29:25	TYPE5	Exception Type 5.
24:20	TYPE4	Exception Type 4.
19:15	TYPE3	Exception Type 3.
14:10	TYPE2	Exception Type 2.
9:5	TYPE1	Exception Type 1.
4:0	TYPE0	Exception Type 0.

Note 1. Table 5-14 shows the definition of the types in the XC\_HIST MSR.

**Table 5-14. XC\_HIST\_MSR Exception Types**

Value	Description	Value	Description	Value	Description
00h	Divide error	0Bh	Segment not present	16h	External system management during I/O instruction
01h	Debug	0Ch	Stack fault	17h	External system management
02h	External non-maskable interrupt	0Dh	General protection fault	18h	Init
03h	Breakpoint	0Eh	Page fault	19h	Reset
04h	Overflow	0Fh	Reserved	1Ah	Internal suspend/stall
05h	Bound	10h	FPU error trap	1Bh	External suspend/stall
06h	Invalid operation code	11h	Alignment fault	1Ch	Unsuspend/unstall
07h	FPU unavailable	12h	FPU error interrupt	1Dh	Triple fault shutdown
08h	Double fault	13h	Internal debug management	1Eh	External maskable interrupt
09h	Self-modified code fault	14h	External debug management	1Fh	No exception
0Ah	Invalid task-state segment	15h	I/O-initiated system management	--	--

**5.5.2.18 XC Microcode Address MSR (XC\_UADDR\_MSR)**

MSR Address 00001213h  
 Type RO  
 Reset Value 00000000\_00000000h

**XC\_UADDR\_MSR Register Map**

63	62	61	60	59	58	57	56	55	54	53	52	51	50	49	48	47	46	45	44	43	42	41	40	39	38	37	36	35	34	33	32
RSVD				UADDR4												UADDR3												UADDR2[11:8]			
31	30	29	28	27	26	25	24	23	22	21	20	19	18	17	16	15	14	13	12	11	10	9	8	7	6	5	4	3	2	1	0
UADDR2[7:0]								UADDR1																UADDR0							

**XC\_UADDR\_MSR Bit Descriptions**

Bit	Name	Description
63:60	RSVD	Reserved.
59:48	UADDR4	Microcode Address for Exception 4.
47:36	UADDR3	Microcode Address for Exception 3.
35:24	UADDR2	Microcode Address for Exception 2.
23:12	UADDR1	Microcode Address for Exception 1.
11:0	UADDR0	Microcode Address for Exception 0. Most recent exception.

**5.5.2.19 ID Configuration MSR (ID\_CONFIG\_MSR)**

MSR Address 00001250h  
 Type R/W  
 Reset Value 00000000\_00000002h

**ID\_CONFIG\_MSR Register Map**

63	62	61	60	59	58	57	56	55	54	53	52	51	50	49	48	47	46	45	44	43	42	41	40	39	38	37	36	35	34	33	32
RSVD																															
31	30	29	28	27	26	25	24	23	22	21	20	19	18	17	16	15	14	13	12	11	10	9	8	7	6	5	4	3	2	1	0
RSVD																										GPF_TR	INV_3DNOW	SERIAL			

**ID\_CONFIG\_MSR Bit Descriptions**

Bit	Name	Description
63:3	RSVD (RO)	Reserved (Read Only).
2	GPF_TR	<b>General Protection Faults on Test Register Accesses.</b> Generate general protection faults on accesses to Test Registers. 0: Disable. (Default) 1: Enable.
1	INV_3DNOW	<b>Inverse 3DNow!™.</b> Inverse AMD 3DNow!™ instructions PFRCPV and RFRSQRTV. 0: Disable. 1: Enable. (Default)
0	SERIAL	<b>Serialize.</b> Serialize the CPU integer pipeline by only allowing one instruction in the pipeline at a time. 0: Integer pipeline is not serialized. (Default) 1: Integer pipeline is serialized.

**5.5.2.20 SMM Control MSR (SMM\_CTL\_MSR)**

MSR Address 00001301h  
 Type R/W  
 Reset Value 00000000\_00000000h

**SMM\_CTL\_MSR Register Map**

63	62	61	60	59	58	57	56	55	54	53	52	51	50	49	48	47	46	45	44	43	42	41	40	39	38	37	36	35	34	33	32	
RSVD																																
31	30	29	28	27	26	25	24	23	22	21	20	19	18	17	16	15	14	13	12	11	10	9	8	7	6	5	4	3	2	1	0	
RSVD																											SMI_EXTL	SMI_IO	SMI_INST	SMM_NEST	SMM_SUSP	SMM_NMI

**SMM\_CTL\_MSR Bit Descriptions**

Bit	Name	Description
63:6	RSVD (RO)	<b>Reserved (Read Only).</b>
5	SMI_EXTL	<b>Enable External ASMI Pin.</b> Enable external asynchronous SMIs. 0: Disable. 1: Enable.
4	SMI_IO	<b>Enable I/O Generated SMI.</b> Enable SMIs caused by an I/O instruction. 0: Disable. 1: Enable.
3	SMI_INST	<b>Enable SMI Instructions.</b> Enable SMI instructions: SMINT, RSM, SVDC, RSDC, SVLDT, RSLDT, SVTS, RSTS. If not enabled, executing an SMI instruction causes an invalid operation fault. 0: Disable. 1: Enable.
2	SMM_NEST	<b>Enable SMI Nesting.</b> Enable non-software SMIs during SMM mode. 0: Disable. 1: Enable.
1	SMM_SUSP	<b>Enable Suspend during SMM.</b> Enable Suspend during SMM mode. 0: Disable. 1: Enable.
0	SMM_NMI	<b>Enable Non-Maskable Interrupts during SMM.</b> Enable NMI during SMM mode. 0: Disable. 1: Enable.



**5.5.2.21 Debug Management Interrupt (DMI) Control Register**

MSR Address 00001302h  
 Type R/W  
 Reset Value 00000000\_00000000h

**DMI Control Register Map**

63	62	61	60	59	58	57	56	55	54	53	52	51	50	49	48	47	46	45	44	43	42	41	40	39	38	37	36	35	34	33	32
RSVD																															
31	30	29	28	27	26	25	24	23	22	21	20	19	18	17	16	15	14	13	12	11	10	9	8	7	6	5	4	3	2	1	0
RSVD																						DMI_TF	DMI_STALL	DMM_SUSP	DMI_TSS	DMM_CACHE	DMI_ICEBP	DMI_DBG	DMI_EXT	DMI_GPF	DMI_INST

**DMI Control Register Bit Descriptions**

Bit	Name	Description
63:10	RSVD	<b>Reserved.</b> Write as read.
9	DMI_TF	<b>DMI Trap Flag.</b> 0: Disable DMI single stepping. 1: If DMI_STALL (bit 8) is 0, DMI occurs after the successful execution of each instruction. If DMI_STALL is 1, debug stall occurs after the successful execution of each instruction.
8	DMI_STALL	<b>DMI Stall.</b> 0: If not in DMM, DMI conditions cause DMIs. 1: DMI conditions cause a debug stall.
7	DMM_SUSP	<b>Enable SUSP# during DMM.</b> Enable SUSP# during DMM mode. 0: Disable. 1: Enable.
6	DMI_TSS	<b>Task Switch Debug Fault Control.</b> 0: Task switch debug faults cause debug exceptions. 1: Task switch debug exceptions cause DMIs when not in DMM.
5	DMM_CACHE	<b>Cache Control during DMM.</b> 0: Do not change CR0 CD and NW bits when entering DMM. 1: Set CR0, CD and NW bits when entering DMM. See Table 5-10 "CR0 Bit Descriptions" on page 96 for CD and NW bit descriptions.
4	DMI_ICEBP	<b>Enable DMIs on ICEBP (F1) Instructions.</b> 0: Disable. 1: Enable.
3	DMI_DBG	<b>Enable Replacing Debug Exceptions as DMIs.</b> 0: Disable. 1: Enable.
2	DMI_EXT	<b>Enable External TDBGI Pin.</b> Enable DMIs caused by the TDBGI pin (ball AB2) when not in DMM. 0: Disable. 1: Enable.

**DMI Control Register Bit Descriptions (Continued)**

Bit	Name	Description
1	DMI_GPF	<b>DMI General Protection Faults.</b> When enabled and not in DMM mode, allow general protection faults to generate DMIs. 0: Disable. 1: Enable.
0	DMI_INST	<b>DMI Instructions.</b> Enable DMI instructions DMINT and RDM. If not enabled, executing a DMI instruction generates an invalid operation fault. 0: Disable. 1: Enable.

**5.5.2.22 Temporary MSRs**

**Temporary 0 MSR (TEMP0\_MSR)**

MSR Address 00001310h  
Type R/W  
Reset Value xxxxxxxx\_xxxxxxxh

**Temporary 2 MSR (TEMP2\_MSR)**

MSR Address 00001312h  
Type R/W  
Reset Value xxxxxxxx\_xxxxxxxh

**Temporary 1 MSR (TEMP1\_MSR)**

MSR Address 00001311h  
Type R/W  
Reset Value xxxxxxxx\_xxxxxxxh

**Temporary 3 MSR (TEMP3\_MSR)**

MSR Address 00001313h  
Type R/W  
Reset Value xxxxxxxx\_xxxxxxxh

**TEMPx\_MSR Register Map**

63	62	61	60	59	58	57	56	55	54	53	52	51	50	49	48	47	46	45	44	43	42	41	40	39	38	37	36	35	34	33	32
RSVD																															
31	30	29	28	27	26	25	24	23	22	21	20	19	18	17	16	15	14	13	12	11	10	9	8	7	6	5	4	3	2	1	0
TEMPx																															

**TEMPx\_MSR Bit Descriptions**

Bit	Name	Description
63:32	RSVD	<b>Reserved.</b> Write as read.
31:0	TEMPx	<b>Temporary x.</b> Used by microcode, usually for holding operands for address calculations.

**5.5.2.23 Segment Selector/Flags MSRs**

The Segment Selector/Flags MSRs provide access to the segment selector and segment flags parts of a segment register. The contents of segment registers should be accessed using MOV or SVDC/RSDC.

**ES Segment Selector/Flags Register (ES\_SEL\_MSR)**

MSR Address 00001320h  
 Type R/W  
 Reset Value xxxxxxxx\_xxxxxxxh

**LDT Segment Selector/Flags Register (LDT\_SEL\_MSR)**

MSR Address 00001326h  
 Type R/W  
 Reset Value xxxxxxxx\_xxxxxxxh

**CS Segment Selector/Flags Register (CS\_SEL\_MSR)**

MSR Address 00001321h  
 Type R/W  
 Reset Value xxxxxxxx\_xxxxxxxh

**Temp Segment Selector/Flags Register (TM\_SEL\_MSR)**

MSR Address 00001327h  
 Type R/W  
 Reset Value xxxxxxxx\_xxxxxxxh

**SS Segment Selector/Flags Register (SS\_SEL\_MSR)**

MSR Address 00001322h  
 Type R/W  
 Reset Value xxxxxxxx\_xxxxxxxh

**TSS Segment Selector/Flags Register (TSS\_SEL\_MSR)**

MSR Address 00001328h  
 Type R/W  
 Reset Value xxxxxxxx\_xxxxxxxh

**DS Segment Selector/Flags Register (DS\_SEL\_MSR)**

MSR Address 00001323h  
 Type R/W  
 Reset Value xxxxxxxx\_xxxxxxxh

**IDT Segment Selector/Flags Register (IDT\_SEL\_MSR)**

MSR Address 00001329h  
 Type R/W  
 Reset Value xxxxxxxx\_xxxxxxxh

**FS Segment Selector/Flags Register (FS\_SEL\_MSR)**

MSR Address 00001324h  
 Type R/W  
 Reset Value xxxxxxxx\_xxxxxxxh

**GDT Segment Selector/Flags Register (GDT\_SEL\_MSR)**

MSR Address 0000132Ah  
 Type R/W  
 Reset Value xxxxxxxx\_xxxxxxxh

**GS Segment Selector/Flags Register (GS\_SEL\_MSR)**

MSR Address 00001325h  
 Type R/W  
 Reset Value xxxxxxxx\_xxxxxxxh

**Segment Selector/Flags MSR Register Map**

63	62	61	60	59	58	57	56	55	54	53	52	51	50	49	48	47	46	45	44	43	42	41	40	39	38	37	36	35	34	33	32
RSVD																															
31	30	29	28	27	26	25	24	23	22	21	20	19	18	17	16	15	14	13	12	11	10	9	8	7	6	5	4	3	2	1	0
G	B/D	RSVD	AVL	RSVD				P	DPL	S	X	E/C	W/R	A	SELECTOR													TI	RPL		

**Segment Selector/Flags MSR Bit Descriptions**

Bit	Name	Description
63:32	RSVD	Reserved.
31	G	Limit Granularity Bit.
30	B/D	Stack Address Size / Code Default Size.
29	RSVD	Reserved.
28	AVL	Available. Bit available for operating system use.
27:24	RSVD	Reserved.
23	P	Present.
22:21	DPL	Descriptor Privilege Level.
20	S	Non-System Descriptor.

## Segment Selector/Flags MSR Bit Descriptions (Continued)

Bit	Name	Description
19	X	Executable Non-System Segment.
18	E/C	Expand Down Data Segment / Conforming Code Segment.
17	W/R	Writable Data Segment / Readable Code Segment.
16	A	Accessed Segment.
15:3	SELECTOR	Segment Selector.
2	TI	Descriptor Table Indicator (LDT/GDT).
1:0	RPL	Requestor Privilege Level.

## 5.5.2.24 SMM Header MSR (SMM\_HDR\_MSR)

MSR Address 0000132Bh  
 Type R/W  
 Reset Value 00000000\_00000000h

The SMM\_HDR\_MSR provides access to the address register that controls where SMI data is written.

## SMM\_HDR\_MSR Register Map

63	62	61	60	59	58	57	56	55	54	53	52	51	50	49	48	47	46	45	44	43	42	41	40	39	38	37	36	35	34	33	32
RSVD																															
31	30	29	28	27	26	25	24	23	22	21	20	19	18	17	16	15	14	13	12	11	10	9	8	7	6	5	4	3	2	1	0
SMM_HDR																															

## SMM\_HDR\_MSR Bit Descriptions

Bit	Name	Description
63:32	RSVD	Reserved. Write as read.
31:0	SMM_HDR	<b>SMM Header.</b> Address that indicates where SMI data is written. SMI data is written at lower addresses than SMM_HDR (negative offsets).

**5.5.2.25 DMM Header MSR (DMM\_HDR\_MSR)**

MSR Address 0000132Ch  
 Type R/W  
 Reset Value 00000000\_00000000h

DMM\_HDR\_MSR provides access to the address register that controls where DMI data is written.

**DMM\_HDR\_MSR Register Map**

63	62	61	60	59	58	57	56	55	54	53	52	51	50	49	48	47	46	45	44	43	42	41	40	39	38	37	36	35	34	33	32
RSVD																															
31	30	29	28	27	26	25	24	23	22	21	20	19	18	17	16	15	14	13	12	11	10	9	8	7	6	5	4	3	2	1	0
DMM_HDR																															

**DMM\_HDR\_MSR Bit Descriptions**

Bit	Name	Description
63:32	RSVD	<b>Reserved.</b> Write as read.
31:0	DMM_HDR	<b>DMM Header.</b> Address that indicates where DMI data is written. DMI data is written at lower addresses than DMM_HDR (negative offsets).

**5.5.2.26 Segment Base/Limit MSRs**

The segment base/limit MSRs provide access to the segment limit and segment base parts of a segment register. The limit value is the true limit; it does not need to be altered based on the limit granularity bit. The contents of segment registers should be accessed using MOV or SVDC/RSDC.

**ES Segment Base/Limit MSR (ES\_BASE\_MSR)**

MSR Address 00001330h  
 Type R/W  
 Reset Value xxxxxxxx\_xxxxxxxh

**Temp Segment Base/Limit MSR (TEMP\_BASE\_MSR)**

MSR Address 00001337h  
 Type R/W  
 Reset Value xxxxxxxx\_xxxxxxxh

**CS Segment Base/Limit MSR (CS\_BASE\_MSR)**

MSR Address 00001331h  
 Type R/W  
 Reset Value xxxxxxxx\_xxxxxxxh

**TSS Segment Base/Limit MSR (TSS\_BASE\_MSR)**

MSR Address 00001338h  
 Type R/W  
 Reset Value xxxxxxxx\_xxxxxxxh

**SS Segment Base/Limit MSR (SS\_BASE\_MSR)**

MSR Address 00001332h  
 Type R/W  
 Reset Value xxxxxxxx\_xxxxxxxh

**IDT Segment Base/Limit MSR (IDT\_BASE\_MSR)**

MSR Address 00001339h  
 Type R/W  
 Reset Value xxxxxxxx\_xxxxxxxh

**DS Segment Base/Limit MSR (DS\_BASE\_MSR)**

MSR Address 00001333h  
 Type R/W  
 Reset Value xxxxxxxx\_xxxxxxxh

**GDT Segment Base/Limit MSR (GDT\_BASE\_MSR)**

MSR Address 0000133Ah  
 Type R/W  
 Reset Value xxxxxxxx\_xxxxxxxh

**FS Segment Base/Limit MSR (FS\_BASE\_MSR)**

MSR Address 00001334h  
 Type R/W  
 Reset Value xxxxxxxx\_xxxxxxxh

**SMM Segment Base/Limit MSR (SMM\_BASE\_MSR)**

MSR Address 0000133Bh  
 Type R/W  
 Reset Value xxxxxxxx\_xxxxxxxh

**GS Segment Base/Limit MSR (GS\_BASE\_MSR)**

MSR Address 00001335h  
 Type R/W  
 Reset Value xxxxxxxx\_xxxxxxxh

**DMM Segment Base/ Limit MSR (DMM\_BASE\_MSR)**

MSR Address 0000133Ch  
 Type R/W  
 Reset Value xxxxxxxx\_xxxxxxxh

**LDT Segment Base/Limit MSR (LDT\_BASE\_MSR)**

MSR Address 00001336h  
 Type R/W  
 Reset Value xxxxxxxx\_xxxxxxxh

**Segment Base/Limit MSR Register Map**

63	62	61	60	59	58	57	56	55	54	53	52	51	50	49	48	47	46	45	44	43	42	41	40	39	38	37	36	35	34	33	32
LIMIT																															
31	30	29	28	27	26	25	24	23	22	21	20	19	18	17	16	15	14	13	12	11	10	9	8	7	6	5	4	3	2	1	0
BASE																															

**Segment Base/Limit MSR Bit Descriptions**

Bit	Name	Description
63:32	LIMIT	Segment Limit.
31:0	BASE	Segment Base.

**5.5.2.27 Debug Registers 1 and 0 MSR (DR1\_DR0\_MSR)**

MSR Address 00001340h  
 Type R/W  
 Reset Value xxxxxxxx\_xxxxxxxh

DR1\_DR0\_MSR provides access to Debug Register 1 (DR1) and Debug Register 0 (DR0). DR0 and DR1 each contain either an I/O port number or a linear address for use as a breakpoint. The contents of debug registers are more easily accessed using the MOV instruction.

**DR1\_DR0\_MSR Register Map**

63	62	61	60	59	58	57	56	55	54	53	52	51	50	49	48	47	46	45	44	43	42	41	40	39	38	37	36	35	34	33	32
DR1																															
31	30	29	28	27	26	25	24	23	22	21	20	19	18	17	16	15	14	13	12	11	10	9	8	7	6	5	4	3	2	1	0
DR0																															

**DR1\_DR0\_MSR Bit Descriptions**

Bit	Name	Description
63:32	DR1	<b>Breakpoint 1 I/O Port Number/Linear Address.</b>
31:0	DR0	<b>Breakpoint 0 I/O Port Number/Linear Address.</b>

**5.5.2.28 Debug Registers 3 and 2 MSR (DR3\_DR2\_MSR)**

MSR Address 00001341h  
 Type R/W  
 Reset Value xxxxxxxx\_xxxxxxxh

DR3/DR2\_MSR provides access to Debug Register 3 (DR3) and Debug Register 2 (DR2). DR2 and DR3 each contain either an I/O port number or a linear address for use as a breakpoint. The contents of debug registers are more easily accessed using the MOV instruction.

**DR3\_DR2\_MSR Register Map**

63	62	61	60	59	58	57	56	55	54	53	52	51	50	49	48	47	46	45	44	43	42	41	40	39	38	37	36	35	34	33	32
DR3																															
31	30	29	28	27	26	25	24	23	22	21	20	19	18	17	16	15	14	13	12	11	10	9	8	7	6	5	4	3	2	1	0
DR2																															

**DR2\_DR3\_MSR Bit Descriptions**

Bit	Name	Description
63:32	DR3	<b>Breakpoint 3 I/O Port Number/Linear Address.</b>
31:0	DR2	<b>Breakpoint 2 I/O Port Number/Linear Address.</b>

### 5.5.2.29 Debug Registers 7 and 6 MSR (DR6\_DR7\_MSR)

MSR Address 00001343h  
 Type R/W  
 Reset Value 00000000\_FFFF0000h

DR7\_DR6\_MSR provides access to Debug Register 7 (DR7) and Debug Register 6 (DR6). DR6 contains status information about debug conditions that have occurred. DR7 contains debug condition enables, types, and lengths. The contents of debug registers are more easily accessed using the MOV instruction.

**DR7\_DR6\_MSR Register Map**

63	62	61	60	59	58	57	56	55	54	53	52	51	50	49	48	47	46	45	44	43	42	41	40	39	38	37	36	35	34	33	32									
LEN3			TYPE3			LEN2			TYPE2			LEN1			TYPE1			LEN0			TYPE0			RSVD		GD	RSVD						G3	L3	G2	L2	G1	L1	G0	L0
31	30	29	28	27	26	25	24	23	22	21	20	19	18	17	16	15	14	13	12	11	10	9	8	7	6	5	4	3	2	1	0									
RSVD (FFFFh)																BT	BS	BD	RSVD (FFh)										B3	B2	B1	B0								

**DR7\_DR6\_MSR Bit Descriptions**

Bit	Name	Description
63:62	LEN3	Breakpoint 3 Length.
61:60	TYPE3	Breakpoint 3 Type.
59:58	LEN2	Breakpoint 2 Length.
57:56	TYPE2	Breakpoint 2 Type.
55:54	LEN1	Breakpoint 1 Length.
53:52	TYPE1	Breakpoint 1 Type.
51:50	LEN0	Breakpoint 0 Length.
49:48	TYPE0	Breakpoint 0 Type.
47:46	RSVD	Reserved.
45	GD	Enable Global Detect Faults.
44:40	RSVD	Reserved.
39, 38	G3, L3	Breakpoint 3 Enables.
37, 36	G2, L2	Breakpoint 2 Enables.
35, 34	G1, L1	Breakpoint 1 Enables.
33, 32	G0, L0	Breakpoint 0 Enables.
31:16	RSVD	Reserved.
15	BT	TSS T-Bit Trap Occured.
14	BS	Single-Step Trap Occured.
13	BD	Global Detect Fault Occured.
12:4	RSVD	Reserved.
3	B3	Breakpoint 3 Matched.
2	B2	Breakpoint 2 Matched.
1	B1	Breakpoint 1 Matched.
0	B0	Breakpoint 0 Matched.



**5.5.2.30 Extended Debug Registers 1 and 0 MSR (XDR1\_XDR0\_MSR)**

MSR Address 00001350h  
 Type R/W  
 Reset Value 00000000\_00000000h

XDR1/XDR0\_MSR provides access to Extended Debug Register 1 (XDR1) and Extended Debug Register 0 (XDR0). XDR0 and XDR1 each contain either an I/O port number or a linear address for use as an extended breakpoint.

**XDR1\_XDR0\_MSR Register Map**

63	62	61	60	59	58	57	56	55	54	53	52	51	50	49	48	47	46	45	44	43	42	41	40	39	38	37	36	35	34	33	32
XDR1																															
31	30	29	28	27	26	25	24	23	22	21	20	19	18	17	16	15	14	13	12	11	10	9	8	7	6	5	4	3	2	1	0
XDR0																															

**XDR1\_XDR0\_MSR Bit Descriptions**

Bit	Name	Description
63:32	XDR1	Extended Breakpoint 1 I/O Port Number/Linear Address.
31:0	XDR0	Extended Breakpoint 0 I/O Port Number/Linear Address.

**5.5.2.31 Extended Debug Registers 3 and 2 MSR (XDR3\_XDR2\_MSR)**

MSR Address 00001351h  
 Type R/W  
 Reset Value 00000000\_00000000h

XDR3/XDR2\_MSR provides access to Extended Debug Register 3 (XDR3) and Extended Debug Register 2 (XDR2). XDR2 and XDR3 each contain either an I/O port number or a linear address for use as an extended breakpoint.

**XDR3\_XDR2\_MSR Register Map**

63	62	61	60	59	58	57	56	55	54	53	52	51	50	49	48	47	46	45	44	43	42	41	40	39	38	37	36	35	34	33	32
XDR3																															
31	30	29	28	27	26	25	24	23	22	21	20	19	18	17	16	15	14	13	12	11	10	9	8	7	6	5	4	3	2	1	0
XDR2																															

**XDR3\_XDR2\_MSR Bit Descriptions**

Bit	Name	Description
63:32	XDR3	Extended Breakpoint 3 I/O Port Number/Linear Address.
31:0	XDR2	Extended Breakpoint 2 I/O Port Number/Linear Address.

**5.5.2.32 Extended Debug Registers 5 and 4 MSR (XDR5\_XDR4\_MSR)**

MSR Address 00001352h  
 Type R/W  
 Reset Value FFFFFFFF\_00000000h

XDR5/XDR4\_MSR provides access to Extended Debug Register 5 (XDR5) and Extended Debug Register 4 (XDR4). XDR4 contains an opcode match value. XDR5 contains an opcode match mask.

**XDR5\_XDR4\_MSR Register Map**

63	62	61	60	59	58	57	56	55	54	53	52	51	50	49	48	47	46	45	44	43	42	41	40	39	38	37	36	35	34	33	32
PREFIX_MASK4								OPCODE_MASK4																							
31	30	29	28	27	26	25	24	23	22	21	20	19	18	17	16	15	14	13	12	11	10	9	8	7	6	5	4	3	2	1	0
PREFIX_VALUE4								OPCODE_VALUE4																							
PN	PR	PL	PC	PS	PO	PA	PF																								

**XDR5\_XDR4\_MSR Bit Descriptions**

Bit	Name	Description
63:56	PREFIX_MASK4	Prefix Mask Value for Extended Breakpoint 4.
55:32	OPCODE_MASK4	Opcode Mask Value for Extended Breakpoint 4.
31	PN	REPNE/REPNZ Prefix Value for Extended Breakpoint 4.
30	PR	REP/REPE/REPZ Prefix Value for Extended Breakpoint 4.
29	PL	LOCK Prefix Value for Extended Breakpoint 4.
28	PC	CS Segment Override Prefix Value for Extended Breakpoint 4.
27	PS	SS/DS/ES/FS/GS Segment Override Prefix Value for Extended Breakpoint 4.
26	PO	Operand Size Prefix Value for Extended Breakpoint 4.
25	PA	Address Size Prefix Value for Extended Breakpoint 4.
24	PF	0F or 0F 0F Prefix Value for Extended Breakpoint 4.
23:0	OPCODE_VALUE4	Opcode Match Value for Extended Breakpoint 4.

**5.5.2.33 Extended Debug Registers 7 and 6 MSR (XDR7\_XDR6\_MSR)**

MSR Address 00001353h  
 Type R/W  
 Reset Value xxxxxxxx\_xxxxxxxh

XDR7\_XDR6\_MSR provides access to the extended breakpoint enables, types, lengths, and status.

**XDR7\_XDR6\_MSR Register Map**

63	62	61	60	59	58	57	56	55	54	53	52	51	50	49	48	47	46	45	44	43	42	41	40	39	38	37	36	35	34	33	32
LEN3	TYPE3	LEN2	TYPE2	LEN1	TYPE1	LEN0	TYPE0	RSVD										E6	E5	E4	E3	E2	E1	E0							
31	30	29	28	27	26	25	24	23	22	21	20	19	18	17	16	15	14	13	12	11	10	9	8	7	6	5	4	3	2	1	0
RSVD (1FFFFh)																	BS	RSVD (1)	BI	RSVD (1Fh)					B6	B5	B5	B3	B2	B1	B0

## XDR7\_XDR6\_MSR Bit Descriptions

Bit	Name	Description
63:62	LEN3	Extended Breakpoint 3 Length.
61:60	TYPE3	Extended Breakpoint 3 Type.
59:58	LEN2	Extended Breakpoint 2 Length.
57:56	TYPE2	Extended Breakpoint 2 Type.
55:54	LEN1	Extended Breakpoint 1 Length.
53:52	TYPE1	Extended Breakpoint 1 Type.
51:50	LEN0	Breakpoint 0 Length.
49:48	TYPE0	Breakpoint 0 Type.
47:39	RSVD	Reserved.
38	E6	Extended Breakpoint 6 Enable.
37	E5	Extended Breakpoint 5 Enable.
36	E4	Extended Breakpoint 4 Enable.
35	E3	Extended Breakpoint 3 Enable.
34	E2	Extended Breakpoint 2 Enable.
33	E1	Extended Breakpoint 1 Enable.
32	E0	Extended Breakpoint 0 Enable.
31:15	RSVD	Reserved. Default = 1FFFFh.
14	BS	Extended Single-Step Trap Status.
13	RSVD	Reserved. Default = 1.
12	BI	ICEBP or INT_1 Status.
11:7	RSVD	Reserved. Default = 1Fh.
6	B6	Extended Breakpoint 6 Status.
5	B5	Extended Breakpoint 5 Status.
4	B4	Extended Breakpoint 4 Status.
3	B3	Extended Breakpoint 3 Status.
2	B2	Extended Breakpoint 2 Status.
1	B1	Extended Breakpoint 1 Status.
0	B0	Extended Breakpoint 0 Status.

**5.5.2.34 Extended Debug Registers 9 and 8 MSR (XDR9\_XDR8\_MSR)**

MSR Address 00001354h  
 Type R/W  
 Reset Value FFFFFFFF\_00000000h

XDR9\_XDR8\_MSR provides access to Extended Debug Register 9 (XDR9) and Extended Debug Register 8 (XDR8). XDR8 contains an opcode match value. XDR9 contains an opcode match mask.

**XDR9\_XDR8\_MSR Register Map**

63	62	61	60	59	58	57	56	55	54	53	52	51	50	49	48	47	46	45	44	43	42	41	40	39	38	37	36	35	34	33	32
PREFIX_MASK5								OPCODE_MASK5																							
31	30	29	28	27	26	25	24	23	22	21	20	19	18	17	16	15	14	13	12	11	10	9	8	7	6	5	4	3	2	1	0
PREFIX_VALUE5								OPCODE_VALUE5																							
PN	PR	PL	PC	PS	PO	PA	PF																								

**XDR9\_XDR8\_MSR Bit Descriptions**

Bit	Name	Description
63:56	PREFIX_MASK5	Prefix Mask Value for Extended Breakpoint 5.
55:32	OPCODE_MASK5	Opcode Mask Value for Extended Breakpoint 5.
31	PN	REPNE/REPNZ Prefix Value for Extended Breakpoint 5.
30	PR	REP/REPE/REPZ Prefix Value for Extended Breakpoint 5.
29	PL	LOCK Prefix Value for Extended Breakpoint 5.
28	PC	CS Segment Override Prefix Value for Extended Breakpoint 5.
27	PS	SS/DS/ES/FS/GS Segment Override Prefix Value for Extended Breakpoint 5.
26	PO	Operand Size Prefix Value for Extended Breakpoint 5.
25	PA	Address Size Prefix Value for Extended Breakpoint 5.
24	PF	0F or 0F 0F Prefix Value for Extended Breakpoint 5.
23:0	OPCODE_VALUE5	Opcode Match Value for Extended Breakpoint 5.

**5.5.2.35 Extended Debug Registers 11 and 10 MSR (XDR11\_XDR10\_MSR)**

MSR Address 00001355h  
 Type R/W  
 Reset Value xxxxxxxx\_xxxx0000h

XDR11\_XDR10\_MSR provides access to the extended I/O breakpoint.

**XDR11\_XDR10\_MSR Register Map**

63	62	61	60	59	58	57	56	55	54	53	52	51	50	49	48	47	46	45	44	43	42	41	40	39	38	37	36	35	34	33	32
RSVD																															
31	30	29	28	27	26	25	24	23	22	21	20	19	18	17	16	15	14	13	12	11	10	9	8	7	6	5	4	3	2	1	0
RSVD																IO_PORT															

**XDR11\_XDR10\_MSR Bit Descriptions**

Bit	Name	Description
63:16	RSVD	<b>Reserved.</b> These bits are not writable.
15:0	IO_PORT	<b>I/O Port for Extended I/O Breakpoint 6.</b>

**5.5.2.36 EX Stage Instruction Pointer MSR (EX\_IP\_MSR)**

MSR Address 00001360h  
 Type R/W  
 Reset Value 00000000\_00000000h

EX\_IP\_MSR provides access to the EX stage instruction pointer (effective address).

**EX\_IP\_MSR Register Map**

63	62	61	60	59	58	57	56	55	54	53	52	51	50	49	48	47	46	45	44	43	42	41	40	39	38	37	36	35	34	33	32
RSVD																															
31	30	29	28	27	26	25	24	23	22	21	20	19	18	17	16	15	14	13	12	11	10	9	8	7	6	5	4	3	2	1	0
EX_IP																															

**EX\_IP\_MSR Bit Descriptions**

Bit	Name	Description
63:32	RSVD	<b>Reserved.</b>
31:0	EX_IP	<b>EX Stage Effective Instruction Pointer.</b>

**5.5.2.37 WB Stage Instruction Pointer MSR (WB\_IP\_MSR)**

MSR Address 00001361h  
 Type R/W  
 Reset Value 00000000\_00000000h

WB\_IP\_MSR provides access to the WB stage instruction pointer (effective address).

**WB\_IP\_MSR Register Map**

63	62	61	60	59	58	57	56	55	54	53	52	51	50	49	48	47	46	45	44	43	42	41	40	39	38	37	36	35	34	33	32
RSVD																															
31	30	29	28	27	26	25	24	23	22	21	20	19	18	17	16	15	14	13	12	11	10	9	8	7	6	5	4	3	2	1	0
WB_IP																															

**WB\_IP\_MSR Bit Descriptions**

Bit	Name	Description
63:32	RSVD	Reserved.
31:0	WB_IP	WB Stage Effective Instruction Pointer.

**5.5.2.38 EX Stage Linear Instruction Pointer MSR (EX\_LIP\_MSR)**

MSR Address 00001364h  
 Type RO  
 Reset Value 00000000\_00000000h

EX\_LIP\_MSR provides access to the EX stage linear instruction pointer.

**EX\_LIP\_MSR Register Map**

63	62	61	60	59	58	57	56	55	54	53	52	51	50	49	48	47	46	45	44	43	42	41	40	39	38	37	36	35	34	33	32
RSVD																															
31	30	29	28	27	26	25	24	23	22	21	20	19	18	17	16	15	14	13	12	11	10	9	8	7	6	5	4	3	2	1	0
EX_LIP																															

**EX\_LIP\_MSR Bit Descriptions**

Bit	Name	Description
63:32	RSVD	Reserved.
31:0	EX_LIP	EX Stage Linear Instruction Pointer.

**5.5.2.39 WB Stage Linear Instruction Pointer MSR (WB\_LIP\_MSR)**

MSR Address 00001365h  
 Type RO  
 Reset Value 00000000\_00000000h

WB\_LIP\_MSR provides access to the WB stage linear instruction pointer.

**WB\_LIP\_MSR Register Map**

63	62	61	60	59	58	57	56	55	54	53	52	51	50	49	48	47	46	45	44	43	42	41	40	39	38	37	36	35	34	33	32
RSVD																															
31	30	29	28	27	26	25	24	23	22	21	20	19	18	17	16	15	14	13	12	11	10	9	8	7	6	5	4	3	2	1	0
WB_LIP																															

**WB\_LIP\_MSR Bit Descriptions**

Bit	Name	Description
63:32	RSVD	Reserved.
31:0	WB_LIP	WB Stage Linear Instruction Pointer.

**5.5.2.40 C1/C0 Linear Instruction Pointer MSR (C1\_C0\_LIP\_MSR)**

MSR Address 00001366h  
 Type RO  
 Reset Value 00000000\_00000000h

C1\_C0\_LIP\_MSR provides access to linear instruction pointers when the code segment was loaded.

**C1\_C0\_LIP\_MSR Register Map**

63	62	61	60	59	58	57	56	55	54	53	52	51	50	49	48	47	46	45	44	43	42	41	40	39	38	37	36	35	34	33	32
C1_LIP																															
31	30	29	28	27	26	25	24	23	22	21	20	19	18	17	16	15	14	13	12	11	10	9	8	7	6	5	4	3	2	1	0
C0_LIP																															

**C1\_C0\_LIP\_MSR Bit Descriptions**

Bit	Name	Description
63:32	C1_LIP	<b>CS 1 Linear Instruction Pointer.</b> Second most recent linear instruction point when code segment was loaded.
31:0	C0_LIP	<b>CS 0 Linear Instruction Pointer.</b> Most recent linear instruction point when code segment was loaded.

### 5.5.2.41 C3/C2 Linear Instruction Pointer MSR (C3\_C2\_LIP\_MSR)

MSR Address 00001367h  
 Type RO  
 Reset Value 00000000\_00000000h

C3\_C2\_LIP\_MSR provides access to linear instruction pointers when the code segment was loaded.

**C3\_C2\_LIP\_MSR Register Map**

63	62	61	60	59	58	57	56	55	54	53	52	51	50	49	48	47	46	45	44	43	42	41	40	39	38	37	36	35	34	33	32
C3_LIP																															
31	30	29	28	27	26	25	24	23	22	21	20	19	18	17	16	15	14	13	12	11	10	9	8	7	6	5	4	3	2	1	0
C2_LIP																															

**C3\_C2\_LIP\_MSR Bit Descriptions**

Bit	Name	Description
63:32	C3_LIP	<b>CS 3 Linear Instruction Pointer.</b> Fourth most recent linear instruction point when code segment was loaded.
31:0	C2_LIP	<b>CS 2 Linear Instruction Pointer.</b> Third most recent linear instruction point when code segment was loaded.

### 5.5.2.42 Floating Point Environment Code Segment (FPENV\_CS\_MSR)

MSR Address 00001370h  
 Type R/W  
 Reset Value 00000000\_00000000h

FPENV\_CS\_MSR provides access to the floating point (FP) environment code segment. Software better accesses the floating point environment data using the FLDENV/FSTENV and FSAVE/FRSTOR instructions.

**FPENV\_CS\_MSR Register Map**

63	62	61	60	59	58	57	56	55	54	53	52	51	50	49	48	47	46	45	44	43	42	41	40	39	38	37	36	35	34	33	32
RSVD																															
31	30	29	28	27	26	25	24	23	22	21	20	19	18	17	16	15	14	13	12	11	10	9	8	7	6	5	4	3	2	1	0
RSVD																CS															

**FPENV\_CS\_MSR Bit Descriptions**

Bit	Name	Description
63:16	RSVD	<b>Reserved.</b>
15:0	CS	<b>Code Segment.</b> Selector of code segment of last FP instruction that may have caused an FP error.



### 5.5.2.43 Floating Point Environment Instruction Pointer (FPENV\_IP\_MSR)

MSR Address 00001371h  
 Type R/W  
 Reset Value 00000000\_00000000h

FPENV\_IP\_MSR provides access to the floating point (FP) environment instruction pointer. Software better accesses the floating point environment data using the FLDENV/FSTENV and FSAVE/FRSTOR instructions.

**FPENV\_IP\_MSR Register Map**

63	62	61	60	59	58	57	56	55	54	53	52	51	50	49	48	47	46	45	44	43	42	41	40	39	38	37	36	35	34	33	32
RSVD																															
31	30	29	28	27	26	25	24	23	22	21	20	19	18	17	16	15	14	13	12	11	10	9	8	7	6	5	4	3	2	1	0
IP																															

**FPENV\_IP\_MSR Bit Descriptions**

Bit	Name	Description
63:32	RSVD	<b>Reserved.</b>
31:0	IP	<b>Instruction Pointer.</b> Effective address of last FP instruction that may have caused an FP error.

### 5.5.2.44 Floating Point Environment Data Segment (FPENV\_DS\_MSR)

MSR Address 00001372h  
 Type R/W  
 Reset Value 00000000\_00000000h

FPENV\_DS\_MSR provides access to the floating point (FP) environment data segment. Software better accesses the floating point environment data using the FLDENV/FSTENV and FSAVE/FRSTOR instructions.

**FPENV\_DS\_MSR Register Map**

63	62	61	60	59	58	57	56	55	54	53	52	51	50	49	48	47	46	45	44	43	42	41	40	39	38	37	36	35	34	33	32
RSVD																															
31	30	29	28	27	26	25	24	23	22	21	20	19	18	17	16	15	14	13	12	11	10	9	8	7	6	5	4	3	2	1	0
RSVD																DS															

**FPENV\_DS\_MSR Bit Descriptions**

Bit	Name	Description
63:16	RSVD	<b>Reserved.</b>
15:0	DS	<b>Data Segment.</b> Selector of data segment of memory operand of last FP instruction that may have caused an FP error.

### 5.5.2.45 Floating Point Environment Data Pointer (FPENV\_DP\_MSR)

MSR Address 00001373h  
 Type R/W  
 Reset Value 00000000\_00000000h

FPENV\_DP\_MSR provides access to the floating point (FP) environment data pointer. Software better accesses the floating point environment data using the FLDENV/FSTENV and FSAVE/FRSTOR instructions.

**FPENV\_DP\_MSR Register Map**

63	62	61	60	59	58	57	56	55	54	53	52	51	50	49	48	47	46	45	44	43	42	41	40	39	38	37	36	35	34	33	32
RSVD																															
31	30	29	28	27	26	25	24	23	22	21	20	19	18	17	16	15	14	13	12	11	10	9	8	7	6	5	4	3	2	1	0
DP																															

**FPENV\_DP\_MSR Bit Descriptions**

Bit	Name	Description
63:32	RSVD	<b>Reserved.</b>
31:0	DP	<b>Data Pointer.</b> Effective address of memory operand of last FP instruction that may have caused an FP error.

### 5.5.2.46 Floating Point Environment Opcode Pointer (FPENV\_OP\_MSR)

MSR Address 00001374h  
 Type R/W  
 Reset Value 00000000\_00000000h

FPENV\_OP\_MSR provides access to the floating point (FP) environment opcode. Software better accesses the floating point environment opcode using the FLDENV/FSTENV and FRSTOR/FSAVE instructions.

**FPENV\_OP\_MSR Register Map**

63	62	61	60	59	58	57	56	55	54	53	52	51	50	49	48	47	46	45	44	43	42	41	40	39	38	37	36	35	34	33	32
RSVD																															
31	30	29	28	27	26	25	24	23	22	21	20	19	18	17	16	15	14	13	12	11	10	9	8	7	6	5	4	3	2	1	0
RSVD																					OP										

**FPENV\_OP\_MSR Bit Descriptions**

Bit	Name	Description
63:11	RSVD	<b>Reserved.</b>
10:0	OP	<b>Opcode Pointer.</b> Opcode of last FP instruction executed that may have caused an FP error.

**5.5.2.47 Address Calculation Unit Configuration MSR (AC\_CONFIG\_MSR)**

MSR Address 00001380h  
 Type RO  
 Reset Value 00000000\_00000000h

**AC\_CONFIG\_MSR Register Map**

63	62	61	60	59	58	57	56	55	54	53	52	51	50	49	48	47	46	45	44	43	42	41	40	39	38	37	36	35	34	33	32
RSVD																															
31	30	29	28	27	26	25	24	23	22	21	20	19	18	17	16	15	14	13	12	11	10	9	8	7	6	5	4	3	2	1	0
RSVD																															LOCK_EN

**AC\_CONFIG\_MSR Bit Descriptions**

Bit	Name	Description
63:1	RSVD	<b>Reserved.</b>
0	LOCK_EN	<b>Lock Enable.</b> Allow Address Calculation Unit (AC) to issue locked requests to Data Memory Subsystem (DM).

5.5.2.48 General Register MSRs

**General Register EAX MSR (GR\_EAX\_MSR)**

MSR Address 00001408h  
 Type R/W  
 Reset Value 00000000\_00000000h

**General Register Temp 0 MSR (GR\_TEMP0\_MSR)**

MSR Address 00001410h  
 Type R/W  
 Reset Value 00000000\_00000000h

**General Register ECX MSR (GR\_ECX\_MSR)**

MSR Address 00001409h  
 Type R/W  
 Reset Value 00000000\_00000000h

**General Register Temp 1 MSR (GR\_TEMP1\_MSR)**

MSR Address 00001411h  
 Type R/W  
 Reset Value 00000000\_00000000h

**General Register EDX MSR (GR\_EDX\_MSR)**

MSR Address 0000140Ah  
 Type R/W  
 Reset Value 00000000\_00000000h

**General Register Temp 2 MSR (GR\_TEMP2\_MSR)**

MSR Address 00001412h  
 Type R/W  
 Reset Value 00000000\_00000000h

**General Register EBX MSR (GR\_EBX\_MSR)**

MSR Address 0000140Bh  
 Type R/W  
 Reset Value 00000000\_00000000h

**General Register Temp 3 MSR (GR\_TEMP3\_MSR)**

MSR Address 00001413h  
 Type R/W  
 Reset Value 00000000\_00000000h

**General Register ESP MSR (GR\_ESP\_MSR)**

MSR Address 0000140Ch  
 Type R/W  
 Reset Value 00000000\_00000000h

**General Register Temp 4 MSR (GR\_TEMP4\_MSR)**

MSR Address 00001414h  
 Type R/W  
 Reset Value 00000000\_00000000h

**General Register EBP MSR (GR\_EBP\_MSR)**

MSR Address 0000140Dh  
 Type R/W  
 Reset Value 00000000\_00000000h

**General Register Temp 5 MSR (GR\_TEMP5\_MSR)**

MSR Address 00001415h  
 Type R/W  
 Reset Value 00000000\_00000000h

**General Register ESI MSR (GR\_ESI\_MSR)**

MSR Address 0000140Eh  
 Type R/W  
 Reset Value 00000000\_00000000h

**General Register Temp 6 MSR (GR\_TEMP6\_MSR)**

MSR Address 00001416h  
 Type R/W  
 Reset Value 00000000\_00000000h

**General Register EDI MSR (GR EDI\_MSR)**

MSR Address 0000140Fh  
 Type R/W  
 Reset Value 00000000\_00000000h

**General Register Temp 7 MSR (GR\_TEMP7\_MSR)**

MSR Address 00001417h  
 Type R/W  
 Reset Value 00000000\_00000000h

**General Registers MSRs Register Map**

63	62	61	60	59	58	57	56	55	54	53	52	51	50	49	48	47	46	45	44	43	42	41	40	39	38	37	36	35	34	33	32
RSVD																															
31	30	29	28	27	26	25	24	23	22	21	20	19	18	17	16	15	14	13	12	11	10	9	8	7	6	5	4	3	2	1	0
GR_REG																															

**General Registers MSRs Bit Descriptions**

Bit	Name	Description
63:32	RSVD	<b>Reserved.</b> Write as read.
31:0	GR_REG	<b>General Register.</b>

**5.5.2.49 Extended Flags MSR (EFLAG\_MSR)**

MSR Address 00001418h  
 Type R/W  
 Reset Value 00000000\_00000002h

**EFLAG\_MSR Register Map**

63	62	61	60	59	58	57	56	55	54	53	52	51	50	49	48	47	46	45	44	43	42	41	40	39	38	37	36	35	34	33	32
RSVD																															
31	30	29	28	27	26	25	24	23	22	21	20	19	18	17	16	15	14	13	12	11	10	9	8	7	6	5	4	3	2	1	0
RSVD (0)										ID	RSVD (0)	AC	VM	RF	RSVD (0)	NT	IOPL	OF	DF	IF	TF	SF	ZF	RSVD (0)	AF	RSVD (0)	PF	RSVD (1)	CF		

**EFLAG\_MSR Bit Descriptions**

Bit	Name	Description
63:22	RSVD	<b>Reserved.</b> (Default = 0)
21	ID	<b>Identification Flag.</b> (Default = 0)
20:19	RSVD	<b>Reserved.</b> (Default = 0)
18	AC	<b>Alignment Check Flag.</b> (Default = 0)
17	VM	<b>Virtual 8086 Flag.</b> (Default = 0)
16	RF	<b>Resume Flag.</b> Disable instruction address breakpoints. (Default = 0)
15	RSVD	<b>Reserved.</b> (Default = 0)
14	NT	<b>Nested Task Flag.</b> (Default = 0)
13:12	IOPL	<b>Input/Output Privilege Level.</b> (Default = 0)
11	OF	<b>Overflow Flag.</b> (Default = 0)
10	DF	<b>Repeated-String Direction Flag.</b> (Default = 0)
9	IF	<b>External Maskable Interrupt Enable.</b> (Default = 0)
8	TF	<b>Single-Step Trap Flag.</b> (Default = 0)
7	SF	<b>Sign Flag.</b> (Default = 0)
6	ZF	<b>Zero Flag.</b> (Default = 0)
5	RSVD	<b>Reserved.</b> (Default = 0)
4	AF	<b>Auxiliary Carry Flag.</b> (Default = 0)
3	RSVD	<b>Reserved.</b> (Default = 0)
2	PF	<b>Parity Flag.</b> (Default = 0)
1	RSVD	<b>Reserved.</b> (Default = 1)
0	CF	<b>Carry Flag.</b> (Default = 1)

**5.5.2.50 Control Register 0 MSR (CR0\_MSR)**

MSR Address 00001420h  
 Type R/W  
 Reset Value 00000000\_60000010h

This is the standard x86 Control Register 0 (CR0). CR1, CR2, CR3, and CR4 are located at MSRs 00001881h-00001884h (see Section 5.5.2.74 on page 172). The contents of CR0-CR4 should only be accessed using the MOV instruction. They are mentioned here for completeness only. See Section 5.4.1 “Control Registers” on page 95 for bit descriptions.

### 5.5.2.51 Instruction Memory Configuration MSR (IM\_CONFIG\_MSR)

MSR Address 00001700h  
 Type R/W  
 Reset Value 00000000\_00000000h

#### IM\_CONFIG\_MSR Register Map

63	62	61	60	59	58	57	56	55	54	53	52	51	50	49	48	47	46	45	44	43	42	41	40	39	38	37	36	35	34	33	32	
RSVD																																
31	30	29	28	27	26	25	24	23	22	21	20	19	18	17	16	15	14	13	12	11	10	9	8	7	6	5	4	3	2	1	0	
LOCK								RSVD								DRT	RSVD				ABSE	EBE	RSVD	ICD	TUS	RSVD	LOD	LOIN	RSVD	SER	FLD	TBE

#### IM\_CONFIG\_MSR Bit Descriptions

Bits	Name	Description
63:32	RSVD	<b>Reserved.</b> (Default = 0)
31:24	LOCK	<b>Lock.</b> Locks ways of the instruction cache from being allocated or replaced on an instruction cache miss. If all ways are locked, caching is effectively disabled.  Bit 31: Ways 15 & 14 Bit 30: Ways 13 & 12 Bit 29: Ways 11 & 10 Bit 28: Ways 9 & 8 Bit 27: Ways 7 & 6 Bit 26: Ways 5 & 4 Bit 25: Ways 3 & 2 Bit 24: Ways 1 & 0  0: Not locked. (Default) 1: Locked
23:17	RSVD	<b>Reserved.</b>
16	DRT	<b>Dynamic Retention Test.</b> Allow dynamic retention test for BIST of tag array.  0: Disable. (Default) 1: Enable.
15:12	RSVD	<b>Reserved.</b> (Default = 0)
11	ABSE	<b>Aborts for Speculative Instruction Fetch Requests Enable.</b> Enable aborts for speculative IF requests for which there is an L1 TLB miss. IM passes the speculative information from IF directly to DM. DM responds in one of four ways:  Returns page if it hits in the L2.  Returns abort if it does not hit in the L2 and it a speculative request.  Returns a retry if it does not hit in the L2 and it was a non-speculative request and the pipe is not idle,  Does a tablewalk if it does not hit in the L2 and it was a non-speculative request and the pipe is idle.  0: Disable. (Default) 1: Enable.
10	EBE	<b>Instruction Memory Eviction Bus Enable.</b> The default is to have IM evictions disabled. This bit should be set when the L2 cache is enabled, since the L2 cache operates exclusively in Victim mode.  0: Disable. Invalidate clean cache lines when replaced, do not evict. (Default) 1: Enable. Evict clean cache lines when they are replaced.
9	RSVD	<b>Reserved.</b>

## IM\_CONFIG\_MSR Bit Descriptions (Continued)

Bits	Name	Description
8	ICD	<b>Instruction Cache Disable.</b> Completely disable L0 and L1 instruction caches. Contents of cache is not modified and no cache entry is read. 0: Use standard x86 cacheability rules. (Default) 1: Instruction cache will always generate a miss.
7	TUS	<b>Translation Look-aside Buffer Updates Select.</b> Select L1 TLB updates (not L1 TLB evictions) to go out on the IM's Translation Bus. Otherwise, only L1 TLB evictions go out on IM's Translation Bus. IM only supports either updates or evictions going out on the bus, but not both. 0: Disable. (Default) 1: Enable.
6	RSVD	<b>Reserved.</b> Always write zero.
5	L0D	<b>L0 Cache Disable.</b> 0: Disable. (Default) 1: Enable.
4	LOIN	<b>L0 Cache Invalidate.</b> 0: Disable. (Default) 1: Enable.
3	RSVD	<b>Reserved.</b>
2	SER	<b>Serialize Cache State Machine.</b> If this bit is set, only one outstanding request to the bus controller is allowed at one time. 0: Disable. (Default) 1: Enable.
1	FLD	<b>Flushing Disable.</b> Disable full flushing of the IM (including outstanding bus controller requests) on IF aborts. If this bit is disabled, the IM only aborts requests that have not already gone out to the bus controller. 0: Enable. (Default) 1: Disable.
0	TBE	<b>Treatment Bus Enable.</b> If this bit is set, then the treatment bus from the GLCP is able to modify the IM's behavior. 0: Disable. (Default) 1: Enable

**5.5.2.52 Instruction Cache Index MSR (IC\_INDEX\_MSR)**

MSR Address 00001710h  
 Type R/W  
 Reset Value 00000000\_00000000h

**IC\_INDEX\_MSR Register Map**

63	62	61	60	59	58	57	56	55	54	53	52	51	50	49	48	47	46	45	44	43	42	41	40	39	38	37	36	35	34	33	32
RSVD																															
31	30	29	28	27	26	25	24	23	22	21	20	19	18	17	16	15	14	13	12	11	10	9	8	7	6	5	4	3	2	1	0
RSVD														DSEL		RSVD				WAY			LINE								

**IC\_INDEX\_MSR Bit Descriptions**

Bits	Name	Description
63:18	RSVD (RO)	<b>Reserved (Read Only).</b>
17:16	DSEL	<b>Data QWORD Select for L1 Cache MSR Access.</b> Determines which QWORD in a cache line is accessed by a read or a write to IC_DATA_MSR (MSR 00001711h). This field resets to 0 on any access to IC_TAG_MSR (MSR 00001712h) or IC_TAG_I_MSR (MSR 00001713h) and increments on access to IC_DATA_MSR. This field is not used when accessing the L0 cache. (Default = 0)
15:11	RSVD (RO)	<b>Reserved (Read Only).</b>
10:7	WAY	<b>L1 Cache Way to Access.</b> Forms the high-order bits of an 11-bit counter. The LINE field (bits [6:0]) forms the low seven bits of the counter. This field increments when the LINE field overflows on a access to IC_TAG_I_MSR (MSR 00001713h). This field is not used for the L0 cache. (Default = 0)
6:0	LINE	<b>L1 Cache Line to Access.</b> Forms the low-order bits of an 11-bit counter. The WAY field (bits [3:0]) forms the high four bits of the counter. This field post-increments on an access to IC_TAG_I_MSR (MSR 00001713h). When accessing the L0 cache, only bits [4:0] are important and are used to select the line to read in the L0 cache. (Default = 0)

**5.5.2.53 Instruction Cache Data MSR (IC\_DATA\_MSR)**

MSR Address 00001711h  
 Type R/W  
 Reset Value xxxxxxxx\_xxxxxxxh

**IC\_DATA\_MSR Register Map**

63	62	61	60	59	58	57	56	55	54	53	52	51	50	49	48	47	46	45	44	43	42	41	40	39	38	37	36	35	34	33	32
DATA (Upper)																															
31	30	29	28	27	26	25	24	23	22	21	20	19	18	17	16	15	14	13	12	11	10	9	8	7	6	5	4	3	2	1	0
DATA (Lower)																															

**IC\_DATA\_MSR Bit Descriptions**

Bits	Name	Description
63:0	DATA	<b>QWORD to Read from or Write to the L1 Cache.</b> The address to the QWORD specified by the LINE and DSEL fields from IC_INDEX_MSR (MSR 00001710h). The way in the cache to read and write is specified by the WAY field in IC_INDEX_MSR. Each access to IC_DATA_MSR increments DSEL.



**5.5.2.54 Instruction Cache Tag (IC\_TAG\_MSR)**

MSR Address 00001712h  
 Type R/W  
 Reset Value 00000000\_00000000h

**IC\_TAG\_MSR MSR Register Map**

63	62	61	60	59	58	57	56	55	54	53	52	51	50	49	48	47	46	45	44	43	42	41	40	39	38	37	36	35	34	33	32
RSVD															LRU																
31	30	29	28	27	26	25	24	23	22	21	20	19	18	17	16	15	14	13	12	11	10	9	8	7	6	5	4	3	2	1	0
TAG																	RSVD										V				

**IC\_TAG\_MSR Bit Descriptions**

Bits	Name	Description
63:47	RSVD (RO)	<b>Reserved (Read Only).</b>
46:32	LRU	<p><b>Least Recently Used Bits for the Cache Line.</b> Same data will be read for all ways in a line. If bit(s) are set to 1:</p> <p>Bit 46: Ways (15-8) more recent than ways (7-0)            Bit 45: Ways (15-12) more recent than ways (11-8)            Bit 44: Ways (15,14) more recent than ways (13,12)            Bit 43: Way 15 more recent than way 14            Bit 42: Way 13 more recent than way 12            Bit 41: Ways (11,10) more recent than ways (9,8)            Bit 40: Way 11 more recent than way 10            Bit 39: Way 9 more recent than way 8            Bit 38: Ways (7-4) more recent than ways (3-0)            Bit 37: Ways (7,6) more recent than ways (5,4)            Bit 36: Way 7 more recent than way 6            Bit 35: Way 5 more recent than way 4            Bit 34: Ways (2,3) more recent than ways (1,0)            Bit 33: Way 3 more recent than way 2            Bit 32: Way 1 more recent than way 0</p>
31:12	TAG	<b>Tag.</b> Cache tag value for the line/way selected by IC_INDEX_MSR (MSR 00001710h). (Default = 0)
11:1	RSVD (RO)	<b>Reserved (Read Only).</b>
0	V	<b>Valid.</b> Valid bit for the line/way selected by IC_INDEX_MSR (MSR 00001710h). (Default = 0)

**5.5.2.55 Instruction Cache Tag with Increment (IC\_TAG\_I\_MSR)**

MSR Address 00001713h  
 Type R/W  
 Reset Value 00000000\_00000000h

**IC\_TAG\_I\_MSR Register Map**

63	62	61	60	59	58	57	56	55	54	53	52	51	50	49	48	47	46	45	44	43	42	41	40	39	38	37	36	35	34	33	32
RSVD														LRU																	
31	30	29	28	27	26	25	24	23	22	21	20	19	18	17	16	15	14	13	12	11	10	9	8	7	6	5	4	3	2	1	0
TAG																RSVD											V				

**IC\_TAG\_I\_MSR Bit Descriptions**

Bit	Name	Description
63:0	---	<b>Definition same as Instruction Cache Tag MSR (MSR 00001712h).</b> Except read/write of this register causes an auto-increment on the IC_INDEX_MSR (MSR 00001710h).

**5.5.2.56 L0 Instruction Cache Data MSR (L0\_IC\_DATA\_MSR)**

MSR Address 00001714h  
 Type RO  
 Reset Value xxxxxxxx\_xxxxxxxh

**L0\_IC\_DATA\_MSR Register Map**

63	62	61	60	59	58	57	56	55	54	53	52	51	50	49	48	47	46	45	44	43	42	41	40	39	38	37	36	35	34	33	32
DATA (Upper)																															
31	30	29	28	27	26	25	24	23	22	21	20	19	18	17	16	15	14	13	12	11	10	9	8	7	6	5	4	3	2	1	0
DATA (Lower)																															

**L0\_IC\_DATA\_MSR Bit Descriptions**

Bits	Name	Description
63:0	DATA	<b>QWORD Read from L0 Cache.</b> The address to the QWORD specified by the LINE field from IC_INDEX_MSR (MSR 00001710h[4:0]).

**5.5.2.57 L0 Instruction Cache Tag with Increment MSR (L0\_IC\_TAG\_I\_MSR)**

MSR Address 00001715h  
 Type RO  
 Reset Value 00000000\_xxxxxxxh

**L0\_IC\_TAG\_I\_MSR Register Map**

63	62	61	60	59	58	57	56	55	54	53	52	51	50	49	48	47	46	45	44	43	42	41	40	39	38	37	36	35	34	33	32
RSVD																															
31	30	29	28	27	26	25	24	23	22	21	20	19	18	17	16	15	14	13	12	11	10	9	8	7	6	5	4	3	2	1	0
TLB_NUM												RSVD						TAG				LINE				RSVD	V				

## L0\_IC\_TAG\_I\_MSR Bit Descriptions

Bits	Name	Description
63:32	RSVD	<b>Reserved.</b>
31:16	TLB_NUM	<b>TLB Number.</b> This is the one-hot-value of the TLB entry corresponding to the L0 cache entry. (Default = 0)
15:12	RSVD	<b>Reserved.</b>
11:8	TAG	<b>Tag/Line.</b> This is a combination of the 4-bit tag and the 5-bit line. Together they make up bits [11:3] of the physical address for the line selected by IC_INDEX_MSR (MSR 00001710h).
7:3	LINE	
2:1	RSVD	<b>Reserved.</b>
0	V	<b>Valid.</b> Valid bit for the line selected by IC_INDEX_MSR (MSR 00001710h). (Default = 0)

## 5.5.2.58 L1 Instruction TLB Index (ITB\_INDEX\_MSR)

MSR Address	00001720h
Type	R/W
Reset Value	00000000_0000000xh

The L1 Instruction TLB is accessible via an index/data mechanism. The index of the entry to access is set via ITB\_INDEX\_MSR and an entry is read or written via ITB\_ENTRY\_MSR or ITB\_ENTRY\_I\_MSR. An autoincrement mechanism is provided to post-increment ITB\_INDEX\_MSR after every access to ITB\_ENTRY\_I\_MSR. The L0 TLB can be accessed by a read only MSR and it is not necessary to use the ITB\_INDEX\_MSR to read the L0 TLB. The L1 TLB LRU bits can be accessed using the ITB\_LRU\_MSR. Diagnostic accesses to the L0 or L1 Instruction TLB array do not affect the values of the LRU bits.

Note that the L1 Instruction TLB is always in use and cannot be disabled. That means that diagnostic accesses generated by code running on the processor are unreliable at best, since the TLB contents may be changing while the code is running. Furthermore, the L1 Instruction TLB is flushed on any mode change, so a debug handler would no longer see the TLB contents prior to the DMI. Thus the L1 Instruction TLB accesses are intended only to be used by the GLCP after the pipeline has been halted.

## ITB\_INDEX\_MSR Register Map

63	62	61	60	59	58	57	56	55	54	53	52	51	50	49	48	47	46	45	44	43	42	41	40	39	38	37	36	35	34	33	32
RSVD																															
31	30	29	28	27	26	25	24	23	22	21	20	19	18	17	16	15	14	13	12	11	10	9	8	7	6	5	4	3	2	1	0
RSVD																											INDEX				

## ITB\_INDEX\_MSR Bit Descriptions

Bits	Name	Description
63:4	RSVD	<b>Reserved.</b>
3:0	INDEX	<b>Index.</b>

**5.5.2.59 L1 Instruction TLB Least Recently Used MSR (ITB\_LRU\_MSR)**

MSR Address 00001721h  
 Type R/W  
 Reset Value 00000000\_00000000h

**ITB\_LRU\_MSR Register Map**

63	62	61	60	59	58	57	56	55	54	53	52	51	50	49	48	47	46	45	44	43	42	41	40	39	38	37	36	35	34	33	32
RSVD																															
31	30	29	28	27	26	25	24	23	22	21	20	19	18	17	16	15	14	13	12	11	10	9	8	7	6	5	4	3	2	1	0
RSVD		LRU																													

**ITB\_LRU\_MSR Bit Descriptions**

Bits	Name	Description
63:30	RSVD (RO)	<b>Reserved (Read Only).</b> (Default = 0)
29:0	LRU	<p><b>Least Recently Used Value.</b></p> <p>Bit 29: Entries 8-11 more recent than entries 12-15                      Bit 28: Entries 4-7 more recent than entries 12-15                      Bit 27: Entries 4-7 more recent than entries 8-11                      Bit 26: Entries 0-3 more recent than entries 12-15                      Bit 25: Entries 0-3 more recent than entries 8-11                      Bit 24: Entries 0-3 more recent than entries 4-7                      Bit 23: Entry 14 more recent than entry 15                      Bit 22: Entry 13 more recent than entry 15                      Bit 21: Entry 13 more recent than entry 14                      Bit 20: Entry 12 more recent than entry 15                      Bit 19: Entry 12 more recent than entry 14                      Bit 18: Entry 12 more recent than entry 13                      Bit 17: Entry 10 more recent than entry 11                      Bit 16: Entry 9 more recent than entry 11                      Bit 15: Entry 9 more recent than entry 10                      Bit 14: Entry 8 more recent than entry 11                      Bit 13: Entry 8 more recent than entry 10                      Bit 12: Entry 8 more recent than entry 9                      Bit 11: Entry 6 more recent than entry 7                      Bit 10: Entry 5 more recent than entry 7                      Bit 9: Entry 5 more recent than entry 6                      Bit 8: Entry 4 more recent than entry 7                      Bit 7: Entry 4 more recent than entry 6                      Bit 6: Entry 4 more recent than entry 5                      Bit 5: Entry 2 more recent than entry 3                      Bit 4: Entry 1 more recent than entry 3                      Bit 3: Entry 1 more recent than entry 2                      Bit 2: Entry 0 more recent than entry 3                      Bit 1: Entry 0 more recent than entry 2                      Bit 0: Entry 0 more recent than entry 1</p> <p>0: False (Default)                      1: True</p>

## 5.5.2.60 L1 Instruction TLB Entry MSRs

**ITB Entry MSR (ITB\_ENTRY\_MSR)**

MSR Address 00001722h  
 Type R/W  
 Reset Value xxxxxxxx\_xxxxxxxh

**ITB L0 Cache Entry MSR (ITB\_L0\_ENTRY\_MSR)**

MSR Address 00001724h  
 Type R/W  
 Reset Value xxxxxxxx\_xxxxxxxh

**ITB Entry with Increment MSR (ITB\_ENTRY\_I\_MSR)**

MSR Address 00001723h  
 Type R/W  
 Reset Value xxxxxxxx\_xxxxxxxh

**ITB\_ENTRY\_MSR, ITB\_ENTRY\_I\_MSR, ITB\_L0\_ENTRY\_MSR Register Map**

63	62	61	60	59	58	57	56	55	54	53	52	51	50	49	48	47	46	45	44	43	42	41	40	39	38	37	36	35	34	33	32
LINADDR											RSVD																				
31	30	29	28	27	26	25	24	23	22	21	20	19	18	17	16	15	14	13	12	11	10	9	8	7	6	5	4	3	2	1	0
PHYSADDR											WS	RSVD						CD	RSVD	US	RSVD	V									

**ITB\_ENTRY\_MSR, ITB\_ENTRY\_I\_MSR, ITB\_L0\_ENTRY\_MSR Bit Descriptions**

Bits	Name	Description
63:44	LINADDR	<b>Linear Address.</b>
43:32	RSVD (RO)	<b>Reserved (Read Only).</b> (Default = 0)
31:12	PHYSADDR	<b>Physical Address.</b>
11	WS	<b>Write Serialize Property.</b> 0: Not write serialized. (Default) 1: Write serialized.
10:5	RSVD (RO)	<b>Reserved (Read Only).</b> (Default = 0)
4	CD	<b>Cache Disable.</b> 0: Cache enabled. 1: Cache disabled.
3	RSVD (RO)	<b>Reserved (Read Only).</b> (Default = 0)
2	US	<b>User Access Privileges.</b> 0: Supervisor. 1: User.
1	RSVD (RO)	<b>Reserved (Read Only).</b> (Default = 0)
0	V	<b>Valid Bit.</b> 0: Not valid. (Default) 1: Valid.

### 5.5.2.61 Instruction Memory Subsystem BIST Tag MSR (IM\_BIST\_TAG\_MSR)

MSR Address 00001730h  
 Type RO  
 Reset Value 00000000\_0000000xh

The Instruction Memory subsystem supports built-in self-test (BIST) for the tag and data arrays. Normally, BIST is run during manufacturing test. For convenience, BIST can be activated by reading the BIST MSRs.

WARNING: It is important that the instruction cache be disabled before initiating BIST via MSRs. There are no guarantees of proper behavior if BIST is activated with the instruction cache enabled. The instruction cache can be disabled through the IM\_CONFIG\_MSR (MSR 00001700h[4]).

#### IM\_BIST\_TAG\_MSR Register Map

63	62	61	60	59	58	57	56	55	54	53	52	51	50	49	48	47	46	45	44	43	42	41	40	39	38	37	36	35	34	33	32
RSVD																															
31	30	29	28	27	26	25	24	23	22	21	20	19	18	17	16	15	14	13	12	11	10	9	8	7	6	5	4	3	2	1	0
RSVD																														CMP	TAG

#### IM\_BIST\_TAG\_MSR Bit Descriptions

Bits	Name	Description
63:2	RSVD (RO)	<b>Reserved (Read Only).</b> (Default = 0)
1	CMP	<b>Tag Compare Logic BIST.</b> 0: Fail (Default) 1: Pass
0	TAG	<b>Valid and Tag Array BIST.</b> 0: Fail (Default) 1: Pass

### 5.5.2.62 Instruction Memory Subsystem BIST Data MSR (IM\_BIST\_DATA\_MSR)

MSR Address 00001731h  
 Type RO  
 Reset Value 00000000\_0000000xh

#### IM\_BIST\_DATA\_MSR Register Map

63	62	61	60	59	58	57	56	55	54	53	52	51	50	49	48	47	46	45	44	43	42	41	40	39	38	37	36	35	34	33	32
RSVD																															
31	30	29	28	27	26	25	24	23	22	21	20	19	18	17	16	15	14	13	12	11	10	9	8	7	6	5	4	3	2	1	0
RSVD																															DATA

#### IM\_BIST\_DATA\_MSR Bit Descriptions

Bits	Name	Description
63:1	RSVD (RO)	<b>Reserved (Read Only).</b> (Default = 0)
0	DATA	<b>Data Array BIST.</b> 0: Fail 1: Pass

### 5.5.2.63 Data Memory Subsystem Configuration 0 MSR (DM\_CONFIG0\_MSR)

MSR Address 00001800h  
 Type R/W  
 Reset Value 00000000\_00000000h

#### DM\_CONFIG0\_MSR Register Map

63	62	61	60	59	58	57	56	55	54	53	52	51	50	49	48	47	46	45	44	43	42	41	40	39	38	37	36	35	34	33	32
RSVD															SNOOPTO	RSVD	WSREQ			RSVD	WCTO			RSVD	WBTO			RSVD			WBDIS
31	30	29	28	27	26	25	24	23	22	21	20	19	18	17	16	15	14	13	12	11	10	9	8	7	6	5	4	3	2	1	0
LSLOCK															NOLOCKEVCT	EVCTONRPL	NOFTTBRES	DTCNINV	P4MDIS	DTCDIS	L2TDIS	DCDIS	SPCDEC	WTBRST	WBINVD	NOSMC	NOFWD	BLOCKC	MISSE	LDSE	

#### DM\_CONFIG0\_MSR Bit Descriptions

Bits	Name	Description
63:49	RSVD	<b>Reserved.</b> (Default = 0)
48	SNOOPTO	<b>Snoop Timeout.</b> Allow DM to escape a snoop deadlock by timing out a snoop request to the DM tag machine. 0: Disable. 1: Enable. (Default)
47	RSVD	<b>Reserved.</b> (Default = 0)
46:44	WSREQ	<b>Number of Outstanding Write-Serialized Requests.</b> The system must be able to accept WSREQ+1 cacheline + 2-4 QWORD writes without backing up the bus controller to prevent a lockup condition in the event of an inbound snoop hit. 000: Unlimited. (Default) 001-111: Binary value.
43	RSVD	<b>Reserved.</b> (Default = 0)
42:40	WCTO	<b>Write-Combine Timeout.</b> Flushes write-combinable entry from write buffer if it has not been written for the specified number of clocks. 000: Disable timeout. (Default) 001-111: $2^{**}(4 + WCTO)$ clocks (32, 64, ..., 2048).
39	RSVD	<b>Reserved.</b> (Default = 0)
38:36	WBTO	<b>Write-Burst Timeout.</b> Flushes write-burstable entry from write buffer if it has not been written for the specified number of clocks. 000: Disable timeout. (Default) 001-111: $2^{**}(4 + WBTO)$ clocks (32, 64, ..., 2048).
35:33	RSVD	<b>Reserved.</b> (Default = 0)

## DM\_CONFIG0\_MSR Bit Descriptions (Continued)

Bits	Name	Description
32	WBDIS	<b>Write Buffer Disable.</b> Disabling the write buffer forces stores to be sent directly from the output of the store queue to the bus controller. Enabling the write buffer allows memory stores to be buffered, with or without combining based on region properties. 0: Enable write buffer. (Default) 1: Disable write buffer. <b>Note:</b> If write allocate is used in any region configuration register, then the write buffer must be enabled.
31:16	LSLOCK	<b>Load/Store Lockout.</b> Bit mask of ways which cannot be allocated or replaced on a load or store miss. If all ways are locked, caching is effectively disabled, though the cache will still be interrogated. Use DCDIS (bit 8) to disable the interrogations as well. Note that this field has been increased from 4 bits in the AMD Geode™ GX processor to 16 bits to allow for the new 16 way cache). (Default = 0)
15	NOLOCKEVCT	<b>Do Not Evict Clean Lines Locked by LSLOCK.</b> When this bit is 1, clean lines locked by LSLOCK will not be evicted into the L2 cache upon replacement. This feature is intended to be used with the auto-prefetch mechanism to prevent auto-prefetched data from getting into the L2 cache. In this case, LSLOCK and APFLOCK would divide the ways of the cache into prefetched and non-prefetched ways. Only the non-prefetched ways would be evicted into the L2. (Default = 0)
14	EVCTONRPL	<b>Evict Clean Lines on Replacement.</b> This bit should be set when an external L2 cache is operating in Victim mode. 0: Invalidate clean cache lines when replaced, do not evict. (Default) 1: Evict clean cache lines when they are replaced.
13	NOFTTBRES	<b>No Page Fault.</b> Do not page fault if any reserved bits are set in the Directory Table Entries (DTE)/Page Table Entries (PTE). 0: Take the page fault. (Default) 1: Do not take the page fault.
12	DTCNINV	<b>Do Not Invalidate DTE Cache Entry.</b> Do not invalidate DTE cache entry on INVLPG instruction. Entire DTE cache is still flushed on a store into the directory page. 0: Invalidate DTE cache entry if INVLPG hits. (Default) 1: Do not invalidate DTE cache entry on INVLPG.
11	P4MDIS	<b>Disable 4M PTE Cache.</b> 0: Allow 4M PTEs to be cached. (Default) 1: Do not cache 4M PTEs and flush any existing entries.
10	DTCDIS	<b>Disable DTE Cache.</b> 0: Allow DTEs to be cached. (Default) 1: Do not cache DTEs, flush any existing entries.
9	L2TDIS	<b>Disable L2 TLB.</b> Contents will not be modified. 0: Interrogate and allocate entries in the L2 TLB. (Default) 1: L2 TLB will always generate a miss.
8	DCDIS	<b>Disable Data Cache (completely).</b> Contents will not be modified. Intended to be used for array testing or in case of cache array failure. 0: Use standard x86 cacheability rules. (Default) 1: Data cache will always generate a miss.



**DM\_CONFIG0\_MSR Bit Descriptions (Continued)**

Bits	Name	Description
7	SPCDEC	<p><b>Decrease Number of Speculative Reads of Data Cache.</b></p> <p>0: Actively resync cache tag and data arrays so that loads can be speculatively handled in one clock if the MRU way is hit. (Default)</p> <p>1: Do not attempt to resync cache tag and data arrays.</p> <p>This is a performance optimization bit and the preferred value may have to be empirically determined. The cache tag and data arrays get “out of sync” when there is a miss to the MRU way or if the data array is busy with a store, linefill, or eviction. While the arrays are out of sync, all hits take 2 clocks. When they are in sync, hits to the MRU way take 1 clock while hits to other ways take 3.</p>
6	WTBRST	<p><b>Write-Through Bursting.</b></p> <p>0: Writes are sent unmodified to the bus on write-through operations. (Default)</p> <p>1: Writes may be combined using write-burstable semantics on write-through operations.</p>
5	WBINVD	<p><b>Convert INVD to WBINVD Instruction.</b></p> <p>0: INVD instruction invalidates cache without writeback. (Default)</p> <p>1: INVD instruction writes back any dirty cache lines</p>
4	NOSMC	<p><b>Snoop Detecting on Self-Modified Code.</b> Generates snoops on stores for detecting self-modified code.</p> <p>0: Generate snoops. (Default)</p> <p>1: Disable snoops.</p>
3	NOFWD	<p><b>Forward Data from Bus Controller.</b> Enable forwarding of data directly from bus controller if a new request hits a line fill in progress.</p> <p>0: Forward data from bus controller if possible. (Default)</p> <p>1: Wait for valid data in cache, then read cache array.</p>
2	BLOCKC	<p><b>Blocking Cache.</b></p> <p>0: New request overlapped with linefill. (Default)</p> <p>1: Linefill must complete before starting new request.</p>
1	MISSEr	<p><b>Serialize Load Misses.</b> Stall everything but snoops on a load miss. Set this bit if part of PCI space is marked as cacheable (e.g., for a ROM), data accesses will be made from that cacheable space, and there is a PCI master device which must complete a master request before it will complete a slave read.</p> <p>0: Load misses are treated the same as load hits. (Default)</p> <p>1: Load misses prevent non-snoop requests from being handled until the miss data is returned by the bus controller.</p>
0	LDSEr	<p><b>Serialize Loads vs Stores.</b> All loads are serialized versus stores in the store queue, but a load that hits the cache completes without affecting any pending stores in the write buffers.</p> <p>0: Loads bypass stores based on region properties. (Default)</p> <p>1: All loads and stores are executed in program order.</p>

**5.5.2.64 Data Memory Subsystem Configuration 1 MSR (DM\_CONFIG1\_MSR)**

MSR Address 00001801h  
 Type R/W  
 Reset Value 00000000\_00000000h

**DM\_CONFIG1\_MSR Register Map**

63	62	61	60	59	58	57	56	55	54	53	52	51	50	49	48	47	46	45	44	43	42	41	40	39	38	37	36	35	34	33	32
RSVD																APFLOCK															
31	30	29	28	27	26	25	24	23	22	21	20	19	18	17	16	15	14	13	12	11	10	9	8	7	6	5	4	3	2	1	0
RSVD						APFMODE	APFENA	RSVD	PFLOCKENA	NOFXEVC	ARRAYDIS					PFXLOCK															

**DM\_CONFIG1\_MSR Bit Descriptions**

Bits	Name	Description
63:48	RSVD	<b>Reserved.</b>
47:32	APFLOCK	<b>Auto-Prefetch Lock.</b> Bit mask of ways that cannot be allocated or replaced on an auto-prefetch issued for a cache miss due to an instruction that is not using the restricted cache prefix. Automatic prefetches that result from restricted cache prefix instructions use the PFXLOCK field (bits [15:0]) for way masking. (Default = 0)
31:27	RSVD	<b>Reserved.</b>
26:25	APFMODE	<b>Auto-Prefetch Mode.</b> When auto-prefetching is enabled via the APFENA bit (bit 24), APFMODE determines how the prefetches are issued as follows:  00: Even Only. An auto-prefetch is issued for the odd cache line when a fill is issued for an even cache line, but no auto-prefetch is issued for a fill on an odd cache line. For example, when a fill request is issued for address 0h, a prefetch will be issued for address 20h. (Default)  01: Even/Odd. Auto-prefetches are issued for an odd cache line when an even fill is issued, and for even cache lines when an odd fill is issued. (i.e the auto-prefetch address is the toggle of fill address A[5]). Using this mode effectively increases the DM logical cache line size to 64 bytes for fills. Line replacements and snoop evictions are still done using a 32-byte line size.  1x: Increment. Auto-prefetches are issued for the next cache line (auto-prefetch line = fill line + 1) when a fill is issued, except for the last cache line in a 4K page (fill address bits [11:5] = 1111111b).
24	APFENA	<b>Auto-Prefetch Enable.</b> Allows DM to perform automatic prefetch operations based on cache fills as specified by the APFMODE field (bits [26:25]).  0: Disable. 1: Enable.
23:22	RSVD	<b>Reserved.</b>
21	PFLOCKENA	<b>Prefetch Prefix Instructions Lock Enable.</b> When this bit is enabled, the LSLOCK field in DM_CONFIG0 (MSR 00001800h[31:16]) determines which ways are available for replacement for all processor memory references except prefetch instructions.  0: Disable the restricted cache feature. (Default) 1: Enable the restricted cache feature (PFXLOCK field, bits [15:0]).

**DM\_CONFIG1\_MSR Bit Descriptions (Continued)**

Bits	Name	Description
20	NOPFXEVCT	<b>No Prefetch Prefix Evictions.</b> This bit disables clean line eviction in the case where a new allocation occurs on a load/store miss when a move string operation uses the REPNZ prefix instead of the normal REP prefix (restricted cache move feature, see PFXLOCK, bits [15:0]). When NOPFXEVCT is set, cache lines replaced by a load instruction using the restricted cache prefix (REPNZ) will not be evicted if they are clean. (See EVCTONRPL bit description in DM_CONFIG0_MSR (MSR 00001800h[14]) for clean line eviction feature). Clean line evictions of this type can be disabled in order to protect the Victim mode L2 cache from being polluted by the transient data being moved. If this bit is a 0, then normal clean line eviction occurs on any line replacement if enabled by the EVCTONRPL bit. Note that any dirty line that is replaced will be evicted regardless of the state of this bit. (Default = 0)
19:16	ARRAYDIS	<b>Array Disable.</b> Mask used to disable individual cache arrays (way groups) in the DM to save power or to avoid array defects. When an array is disabled, the DM will not read or write the data array or tag array associated with this way group, reducing power. Any data in the cache must be flushed before disabling an array or it will be lost.  Bit 19: Ways 15-12 Bit 18: Ways 11-8 Bit 17: Ways 7-4 Bit 16: Ways 3-0  0: Enable. (Default) 1: Disable.
15:0	PFXLOCK	<b>Prefetch Prefix Instructions Lock.</b> Bit mask of ways that cannot be allocated or replaced on a load miss when a move string operation uses the REPNZ prefix (instead of the normal REP prefix). If all ways are locked, caching is effectively disabled, though the cache will still be interrogated. Note that the REPNZ prefix has no effect on PREFETCH instructions or writes to a write-allocate region that miss the cache and cause a write-allocate. (Default = 0)

**5.5.2.65 Data Memory Subsystem Prefetch Lock MSR (DM\_PFLOCK\_MSR)**

MSR Address 00001804h  
 Type R/W  
 Reset Value 00000000\_00000000h

**DM\_PFLOCK\_MSR Register Map**

63	62	61	60	59	58	57	56	55	54	53	52	51	50	49	48	47	46	45	44	43	42	41	40	39	38	37	36	35	34	33	32
PFLOCKT2																PFLOCKT1															
31	30	29	28	27	26	25	24	23	22	21	20	19	18	17	16	15	14	13	12	11	10	9	8	7	6	5	4	3	2	1	0
PFLOCKT0																PFLOCKNTA															

## DM\_PFLOCK\_MSR Bit Descriptions

Bits	Name	Description
63:48	PFLOCKT2	<b>Prefetch Lockout of PREFETCHT2.</b> Bit mask of ways that cannot be allocated or replaced on a data prefetch miss on a PREFETCHT2 instruction. If all ways are locked, PREFETCHT2 is effectively disabled. Use this field to prevent data prefetch operations from polluting too much of the cache. (Default = 0)
47:32	PFLOCKT1	<b>Prefetch Lockout of PREFETCHT1.</b> Bit mask of ways that cannot be allocated or replaced on a data prefetch miss on a PREFETCHT1 instruction. If all ways are locked, PREFETCHT1 is effectively disabled. Use this field to prevent data prefetch operations from polluting too much of the cache. (Default = 0)
31:16	PFLOCKT0	<b>Prefetch Lockout of PREFETCHT0.</b> Bit mask of ways that cannot be allocated or replaced on a data prefetch miss on a PREFETCHT0 instruction. If all ways are locked, PREFETCHT0 is effectively disabled. Use this field to prevent data prefetch operations from polluting too much of the cache. (Default = 0)
15:0	PFLOCKNTA	<b>Prefetch Lockout of PREFETCHNTA.</b> Bit mask of ways that cannot be allocated or replaced on a data prefetch miss on a PREFETCHNTA instruction. If all ways are locked, PREFETCHNTA is effectively disabled. Use this field to prevent data prefetch operations from polluting too much of the cache. (Default = 0)

## 5.5.2.66 Default Region Configuration Properties MSR (RCONF\_DEFAULT\_MSR)

MSR Address 00001808h  
 Type R/W  
 Reset Value 01FFFFFF0\_10000001h  
 Warm Start Value 04xxxxx0\_1xxxxx01h

## RCONF\_DEFAULT\_MSR Register Map

63	62	61	60	59	58	57	56	55	54	53	52	51	50	49	48	47	46	45	44	43	42	41	40	39	38	37	36	35	34	33	32
ROMRP								ROMBASE																DEVRP							
31	30	29	28	27	26	25	24	23	22	21	20	19	18	17	16	15	14	13	12	11	10	9	8	7	6	5	4	3	2	1	0
DEVRP				SYSTOP																SYSRP											

## RCONF\_DEFAULT\_MSR Bit Descriptions

Bit	Name	Description
63:56	ROMRP	<b>ROM Region Properties.</b> Region properties for addresses greater than ROMBASE (bits 55:36).
55:36	ROMBASE	<b>ROM Base Address.</b> Base address for boot ROM. This field represents A[32:12] of the memory address space, 4 KB granularity.
35:28	DEVRP	<b>SYSTOP to ROMBASE Region Properties.</b> Region properties for addresses less than ROMBASE (bits 55:36) and addresses greater than or equal to SYSTOP (bits [27:8]).
27:8	SYSTOP	<b>Top of System Memory.</b> Top of system memory that is available for general processor use. The frame buffer and other private memory areas are located above SYSTOP.
7:0	SYSRP	<b>System Memory Region Properties.</b> Region properties for addresses less than SYSTOP (bits [27:8]). Note that Region Configuration 000A0000h-000FFFFFFh takes precedence over SYSRP.
<b>Note:</b> Region Properties: Bits [7:6] = RSVD; Bit 5 = WS; Bit 4 = WC; Bit 3 = WT; Bit 2 = WP; Bit 1 = WA; Bit 0 = CD. See "Region Properties" on page 170 for further details.		

**5.5.2.67 Region Configuration Bypass MSR (RCONF\_BYPASS\_MSR)**

MSR Address 0000180Ah  
 Type R/W  
 Reset Value 00000000\_00000101h  
 Warm Start Value 00000000\_00000219h

**RCONF\_BYPASS\_MSR Register Map**

63	62	61	60	59	58	57	56	55	54	53	52	51	50	49	48	47	46	45	44	43	42	41	40	39	38	37	36	35	34	33	32
RSVD																															
31	30	29	28	27	26	25	24	23	22	21	20	19	18	17	16	15	14	13	12	11	10	9	8	7	6	5	4	3	2	1	0
RSVD																RPSMHDR								RPTLB							

**RCONF\_BYPASS\_MSR Bit Descriptions**

Bit	Name	Description
63:16	RSVD	<b>Reserved.</b>
15:8	RPSMHDR	<b>Region Properties during SMM/DMM.</b> Region configuration properties used during SMM/DMM header accesses.
7:0	RPTLB	<b>Region Properties during Tablewalks.</b>
<b>Note:</b> Region Properties: Bits [7:6] = RSVD; Bit 5 = WS; Bit 4 = WC; Bit 3 = WT; Bit 2 = WP; Bit 1 = WA; Bit 0 = CD. See "Region Properties" on page 170 for further details.		

**5.5.2.68 Region Configuration A0000-BFFFF MSR (RCONF\_A0\_BF\_MSR)**

MSR Address 0000180Bh  
 Type R/W  
 Reset Value 01010101\_01010101h  
 Warm Start Value 19191919\_19191919h

**RCONF\_A0\_BF\_MSR Register Map**

63	62	61	60	59	58	57	56	55	54	53	52	51	50	49	48	47	46	45	44	43	42	41	40	39	38	37	36	35	34	33	32
RPBC								RPB8								RPB4								RPB0							
31	30	29	28	27	26	25	24	23	22	21	20	19	18	17	16	15	14	13	12	11	10	9	8	7	6	5	4	3	2	1	0
RPAC								RPA8								RPA4								RPA0							

**RCONF\_A0\_BF\_MSR Bit Descriptions**

Bit	Name	Description
63:56	RPBC	<b>Region Properties for 000BC000-000BFFFF.</b>
55:48	RPB8	<b>Region Properties for 000B8000-000BBFFF.</b>
47:40	RPB4	<b>Region Properties for 000B4000-000BAFFF.</b>
39:32	RPB0	<b>Region Properties for 000B0000-000B3FFF.</b>
31:24	RPAC	<b>Region Properties for 000AC000-000AFFFF.</b>
23:16	RPA8	<b>Region Properties for 000A8000-000ABFFF.</b>
15:8	RPA4	<b>Region Properties for 000A4000-000A7FFF.</b>
7:0	RPA0	<b>Region Properties for 000A0000-000A3FFF.</b>
<b>Note:</b> Region Properties: Bits [7:6] = RSVD; Bit 5 = WS; Bit 4 = WC; Bit 3 = WT; Bit 2 = WP; Bit 1 = WA; Bit 0 = CD. See "Region Properties" on page 170 for further details.		

**5.5.2.69 Region Configuration C0000-DFFFF MSR (RCONF\_C0\_DF\_MSR)**

MSR Address 0000180Ch  
 Type R/W  
 Reset Value 01010101\_01010101h  
 Warm Start Value 19191919\_19191919h

**RCONF\_C0\_DF\_MSR Register Map**

63	62	61	60	59	58	57	56	55	54	53	52	51	50	49	48	47	46	45	44	43	42	41	40	39	38	37	36	35	34	33	32
RPDC								RPD8								RPD4								RPD0							
31	30	29	28	27	26	25	24	23	22	21	20	19	18	17	16	15	14	13	12	11	10	9	8	7	6	5	4	3	2	1	0
RPCC								RPC8								RPC4								RPC0							

**RCONF\_C0\_DF\_MSR Bit Descriptions**

Bit	Name	Description
63:56	RPDC	Region Properties for 000DC000-000DFFFF.
55:48	RPD8	Region Properties for 000D8000-000DBFFF.
47:40	RPD4	Region Properties for 000D4000-000DAFFF.
39:32	RPD0	Region Properties for 000D0000-000D3FFF.
31:24	RPCC	Region Properties for 000CC000-000CFFFF.
23:16	RPC8	Region Properties for 000C8000-000CBFFF.
15:8	RPC4	Region Properties for 000C4000-000C7FFF.
7:0	RPC0	Region Properties for 000C0000-000C3FFF.
<b>Note:</b> Region Properties: Bits [7:6] = RSVD; Bit 5 = WS; Bit 4 = WC; Bit 3 = WT; Bit 2 = WP; Bit 1 = WA; Bit 0 = CD. See "Region Properties" on page 170 for further details.		

**5.5.2.70 Region Configuration E0000-FFFFF MSR (RCONF\_E0\_FF\_MSR)**

MSR Address 0000180Dh  
 Type R/W  
 Reset Value 01010101\_01010101h  
 Warm Start Value 19191919\_19191919h

**RCONF\_E0\_FF\_MSR Register Map**

63	62	61	60	59	58	57	56	55	54	53	52	51	50	49	48	47	46	45	44	43	42	41	40	39	38	37	36	35	34	33	32
RPFC								RPF8								RPF4								RIF0							
31	30	29	28	27	26	25	24	23	22	21	20	19	18	17	16	15	14	13	12	11	10	9	8	7	6	5	4	3	2	1	0
RPEC								RPE8								RPE4								RPE0							

## RCONF\_E0\_FF\_MSR Bit Descriptions

Bit	Name	Description
63:56	RPF8	Region Properties for 000FC000-000FFFFF.
55:48	RPF8	Region Properties for 000F8000-000FBFFF.
47:40	RPF4	Region Properties for 000F4000-000FAFFF.
39:32	RPF0	Region Properties for 000F0000-000F3FFF.
31:24	RPEC	Region Properties for 000EC000-000EFFFF.
23:16	RPE8	Region Properties for 000E8000-000EBFFF.
15:8	RPE4	Region Properties for 000E4000-000E7FFF.
7:0	RPE0	Region Properties for 000E0000-000E3FFF.
<b>Note:</b> Region Properties: Bits [7:6] = RSVD; Bit 5 = WS; Bit 4 = WC; Bit 3 = WT; Bit 2 = WP; Bit 1 = WA; Bit 0 = CD. See "Region Properties" on page 170 for further details.		

## 5.5.2.71 Region Configuration SMM MSR (RCONF\_SMM\_MSR)

MSR Address 0000180Eh  
 Type R/W  
 Reset Value 00000001\_00000001h  
 Warm Start Value xxxxx001\_xxxxx005h

## RCONF\_SMM\_MSR Register Map

63	62	61	60	59	58	57	56	55	54	53	52	51	50	49	48	47	46	45	44	43	42	41	40	39	38	37	36	35	34	33	32
SMMTOP												RSVD				RPSMM															
31	30	29	28	27	26	25	24	23	22	21	20	19	18	17	16	15	14	13	12	11	10	9	8	7	6	5	4	3	2	1	0
SMMBASE												RSVD				RPSMM_EN	SMM_NORM														

## RCONF\_SMM\_MSR Bit Descriptions

Bit	Name	Description
63:44	SMMTOP	<b>Top of SMM.</b> Top of SMM region, 4 KB granularity inclusive.
43:40	RSVD	<b>Reserved.</b>
39:32	RPSMM	<b>Region Properties in SMM Region when SMM Active.</b>
31:12	SMMBASE	<b>Start of SMM.</b> Start of SMM region, 4 KB granularity inclusive
11:9	RSVD	<b>Reserved.</b>
8	RPSMM_EN	<b>SMM Properties Region Enable.</b> 0: Disable. 1: Enable.
7:0	SMM_NORM	<b>Region Properties in SMM Region when SMM Inactive.</b>
<b>Note:</b> Region Properties: Bits [7:6] = RSVD; Bit 5 = WS; Bit 4 = WC; Bit 3 = WT; Bit 2 = WP; Bit 1 = WA; Bit 0 = CD. See "Region Properties" on page 170 for further details.		

**5.5.2.72 Region Configuration DMM MSR (RCONF\_DMM\_MSR)**

MSR Address 0000180Fh  
 Type R/W  
 Reset Value 00000001\_00000001h  
 Warm Start Value xxxxx001\_xxxxx005h

**RCONF\_DMM\_MSR Register Map**

63	62	61	60	59	58	57	56	55	54	53	52	51	50	49	48	47	46	45	44	43	42	41	40	39	38	37	36	35	34	33	32
DMMTOP												RSVD				RPDMM															
31	30	29	28	27	26	25	24	23	22	21	20	19	18	17	16	15	14	13	12	11	10	9	8	7	6	5	4	3	2	1	0
DMMBASE												RSVD				RPDMM_EN	DMM_NORM														

**RCONF\_DMM\_MSR Register Bit Descriptions**

Bit	Name	Description
63:44	DMMTOP	<b>Top of DMM.</b> Top of DMM region, 4 KB granularity inclusive.
43:40	RSVD	<b>Reserved.</b>
39:32	RPDMM	<b>Region Properties in DMM Region when DMM Active.</b>
31:12	DMMBASE	<b>Start of DMM.</b> Start of DMM region, 4 KB granularity inclusive.
11:9	RSVD	<b>Reserved.</b>
8	RPDMM_EN	<b>DMM Properties Region Enable.</b> 0: Disable. 1: Enable.
7:0	DMM_NORM	<b>Region Properties in DMM Region when DMM Inactive.</b>

**Note:** Region Properties: Bits [7:6] = RSVD; Bit 5 = WS; Bit 4 = WC; Bit 3 = WT; Bit 2 = WP; Bit 1 = WA; Bit 0 = CD. See "Region Properties" on page 170 for further details.



**5.5.2.73 Region Configuration Range MSRs 0 through 7**

**Region Configuration Range 0 MSR (RCONF0\_MSR)**

MSR Address 00001810h  
 Type R/W  
 Reset Value 00000000\_00000000h  
 Warm Start Value xxxxx000\_xxxxx0xxh

**Region Configuration Range 4 MSR (RCONF4\_MSR)**

MSR Address 00001814h  
 Type R/W  
 Reset Value 00000000\_00000000h  
 Warm Start Value xxxxx000\_xxxxx0xxh

**Region Configuration Range 1 MSR (RCONF1\_MSR)**

MSR Address 00001811h  
 Type R/W  
 Reset Value 00000000\_00000000h  
 Warm Start Value xxxxx000\_xxxxx0xxh

**Region Configuration Range 5 MSR (RCONF5\_MSR)**

MSR Address 00001815h  
 Type R/W  
 Reset Value 00000000\_00000000h  
 Warm Start Value xxxxx000\_xxxxx0xxh

**Region Configuration Range 2 MSR (RCONF2\_MSR)**

MSR Address 00001812h  
 Type R/W  
 Reset Value 00000000\_00000000h  
 Warm Start Value xxxxx000\_xxxxx0xxh

**Region Configuration Range 6 MSR (RCONF6\_MSR)**

MSR Address 00001816h  
 Type R/W  
 Reset Value 00000000\_00000000h  
 Warm Start Value xxxxx000\_xxxxx0xxh

**Region Configuration Range 3 MSR (RCONF3\_MSR)**

MSR Address 00001813h  
 Type R/W  
 Reset Value 00000000\_00000000h  
 Warm Start Value xxxxx000\_xxxxx0xxh

**Region Configuration Range 7 MSR (RCONF7\_MSR)**

MSR Address 00001817h  
 Type R/W  
 Reset Value 00000000\_00000000h  
 Warm Start Value xxxxx000\_xxxxx0xxh

**RCONFx\_MSR Register Map**

63	62	61	60	59	58	57	56	55	54	53	52	51	50	49	48	47	46	45	44	43	42	41	40	39	38	37	36	35	34	33	32
RPTOP												RSVD																			
31	30	29	28	27	26	25	24	23	22	21	20	19	18	17	16	15	14	13	12	11	10	9	8	7	6	5	4	3	2	1	0
RPBASE												RSVD		RPEN	RP																

**RCONFx\_MSR Bit Descriptions**

Bit	Name	Description
63:44	RPTOP	<b>Top of Range.</b> 4 KB granularity, inclusive.
43:32	RSVD	<b>Reserved.</b>
31:12	RPBASE	<b>Start of Range.</b> 4 KB granularity, inclusive.
11:9	RSVD	<b>Reserved.</b>
8	RPEN	<b>Enable Range.</b> 0: Disable range. 1: Enable range.
7:0	RP	<b>Range Properties.</b>
<p><b>Note:</b> Region Properties: Bits [7:6] = RSVD; Bit 5 = WS; Bit 4 = WC; Bit 3 = WT; Bit 2 = WP; Bit 1 = WA; Bit 0 = CD. See "Region Properties" on page 170 for further details.</p>		

### Region Properties

The region properties consist of an 8-bit field as shown in Table 5-15. Table 5-16 and Table 5-17 describe the various region properties effects on read and write operations. Note that the cache is always interrogated even in regions that are not cacheable, and read hits are serviced from the cache while write hits update the cache and are sent to the bus using the region's write semantics.

**Table 5-15. Region Properties Register Map**

7	6	5	4	3	2	1	0
(RSVD) Reserved		WS (Write-serialize)	WC (Write-combine)	WT (Write-through)	WP (Write-protect)	WA (Write-allocate)	CD (Cache Disable)

**Table 5-16. Read Operations vs. Region Properties**

WS	WC	WT	WP	WA	CD	Description
0	x	x	x	x	0	<b>Cacheable.</b> Read misses cause a cache line to be allocated.
1	x	x	x	x	0	<b>Undefined State.</b> Unpredictable behavior occurs.
x	x	x	x	x	1	<b>Uncacheable.</b> Reads are sent unmodified to the bus. Cache is still interrogated and provides data for read hits. Used for accessing memory-mapped devices.
<b>Note:</b> "x" indicates setting or clearing this bit has no effect.						

**Table 5-17. Write Operations vs. Region Properties**

WS	WC	WT	WP	WA	CD	Description
x	x	x	1	x	x	<b>Write-protected.</b> Writes to the region are discarded.
1	x	x	x	x	0	<b>Undefined State.</b> Unpredictable behavior occurs.
x	1	x	x	x	0	<b>Undefined State.</b> Unpredictable behavior occurs.
x	x	x	x	1	1	<b>Undefined State.</b> Unpredictable behavior occurs.
0	0	0	0	0	0	<b>Write-back Cacheable.</b> Write misses are sent to the bus, a cache line is not allocated on a write miss.
0	0	0	0	1	0	<b>Write-back Cacheable/Write-allocate.</b> Write misses allocate a line in the cache.
0	0	1	0	x	0	<b>Write-through cacheable.</b> Write misses do not allocate a line in the cache. Write hits update the cache but do not mark the line as dirty. All writes are sent to the bus.
0	0	0	0	0	1	<b>Uncacheable.</b> All writes are sent to the bus in strict program order without any combining. Write hits still update the cache. Traditionally used for accessing memory-mapped devices (but see write-burstable below).
1	0	0	0	0	1	<b>Uncacheable.</b> All writes are sent to the bus in strict program order without any combining. Write hits still update the cache. Traditionally used for accessing memory-mapped devices (but see write-burstable below). <b>Write-serialize.</b> Limit the number of outstanding writes to the value of the WSREQ field in DM_CONFIG0_MSR (MSR 00001800h[46:44]).
0	1	0	0	0	1	<b>Write-combined (uncacheable).</b> Writes to the same cache line may be combined. Multiple writes to the same byte results in a single write with the last value specified. Write order is not preserved; ideal for use with frame buffers.

Table 5-17. Write Operations vs. Region Properties (Continued)

WS	WC	WT	WP	WA	CD	Description
1	1	0	0	0	1	<p><b>Write-combined (uncacheable).</b> Writes to the same cache line may be combined. Multiple writes to the same byte results in a single write with the last value specified. Write order is not preserved; ideal for use with frame buffers.</p> <p><b>Write-serialize.</b> Limit the number of outstanding writes to the value of the WSREQ field in DM_CONFIG0_MSR (MSR 00001800h[46:44]).</p>
0	1	1	0	0	1	<p><b>Write-burstable (uncacheable).</b> Writes to the same cache line are combined as long as they are to increasing addresses and do not access a previously written byte. Multiple writes to the same byte results in multiple bytes on the bus. The semantics match write bursting on PCI and should therefore be suitable for accessing memory-mapped devices.</p>
1	1	1	0	0	1	<p><b>Write-burstable (uncacheable).</b> Writes to the same cache line are combined as long as they are to increasing addresses and do not access a previously written byte. Multiple writes to the same byte results in multiple bytes on the bus. The semantics match write bursting on PCI and should therefore be suitable for accessing memory-mapped devices.</p> <p><b>Write-serialize.</b> Limit the number of outstanding writes to the value of the WSREQ field in DM_CONFIG0_MSR (MSR 00001800h[46:44]).</p>
<b>Note:</b> "x" indicates setting or clearing this bit has no effect.						

If paging is enabled, the region properties can be further modified by the PCD and PWT flags in the page table entry. The PCD flag is OR'd with the CD bit of the region properties, and the PWT bit is OR'd with the WT bit of the region properties. A similar combination is performed during tablewalks using the PCD/PWT bits from CR3 for the DTE access and the PCD/PWT bits from the DTE for the PTE access. The net effect is that the WC and WS flags may actually be used even for a region that is marked cacheable if a page table mapping later forces it to be uncacheable. For regions that are write-combined, the PWT flag in the page table can be used to force write-burstable properties for selected pages.

**5.5.2.74 x86 Control Registers MSRs (CR1, CR2, CR3, CR4)**

These are the standard x86 Control Registers CR1, CR2, CR3, and CR4. CR0 is located at MSR 00001420h (see Section 5.5.2.50 on page 149). The contents of CR0-CR4 should only be accessed using the MOV instruction. They are mentioned here for completeness only. See Section 5.4.1 “Control Registers” on page 95 for bit descriptions

**x86 Control Register 1 MSR (CR1\_MSR)**

MSR Address 00001881h  
 Type R/W  
 Reset Value 00000000\_xxxxxxxxh

**x86 Control Register 3 MSR (CR3\_MSR)**

MSR Address 00001883h  
 Type R/W  
 Reset Value 00000000\_xxxxxxxxh

**x86 Control Register 2 MSR (CR2\_MSR)**

MSR Address 00001882h  
 Type R/W  
 Reset Value 00000000\_xxxxxxxxh

**x86 Control Register 4 MSR (CR4\_MSR)**

MSR Address 00001884h  
 Type R/W  
 Reset Value 00000000\_xxxxxxxxh

**5.5.2.75 Data Cache Index MSR (DC\_INDEX\_MSR)**

MSR Address 00001890h  
 Type R/W  
 Reset Value 00000000\_00000000h

**DC\_INDEX\_MSR Register Map**

63	62	61	60	59	58	57	56	55	54	53	52	51	50	49	48	47	46	45	44	43	42	41	40	39	38	37	36	35	34	33	32
RSVD																															
31	30	29	28	27	26	25	24	23	22	21	20	19	18	17	16	15	14	13	12	11	10	9	8	7	6	5	4	3	2	1	0
RSVD														DC_DSEL		RSVD						DC_LINE					DC_WAY				

**DC\_INDEX\_MSR Bit Descriptions**

Bit	Name	Description
63:18	RSVD (RO)	<b>Reserved (Read Only).</b>
17:16	DC_DSEL	<b>Data QWORD Select.</b> Determines which QWORD in a cache line is accessed by a read or a write to DC_DATA_MSR (MSR 00001891h). DC_DSEL increments on accesses to DC_DATA and resets to 0 on accesses to DC_TAG_MSR (MSR 00001892h) or DC_TAG_I_MSR (MSR 00001893h).
15:11	RSVD (RO)	<b>Reserved (Read Only).</b>
10:4	DC_LINE	<b>Cache Line Select.</b> Forms the high 7 bits of a 9-bit counter. The DC_WAY field (bits [1:0]) forms the low 2 bits of the counter. This field increments when DC_WAY overflows on an access to DC_TAG_I_MSR (MSR 00001893h).
3:0	DC_WAY	<b>Cache Way Select.</b> Forms the low 2 bits of a 9-bit counter. The DC_LINE field (bits [10:4]) forms the high 7 bits of the counter. This field post-increments on accesses to DC_TAG_I_MSR (MSR 00001893h).

**5.5.2.76 Data Cache Data MSR (DC\_DATA\_MSR)**

MSR Address 00001891h  
 Type R/W  
 Reset Value 00000000\_00000000h

**DC\_DATA\_MSR Register Map**

63	62	61	60	59	58	57	56	55	54	53	52	51	50	49	48	47	46	45	44	43	42	41	40	39	38	37	36	35	34	33	32
DC_DATA																															
31	30	29	28	27	26	25	24	23	22	21	20	19	18	17	16	15	14	13	12	11	10	9	8	7	6	5	4	3	2	1	0
DC_DATA																															

**DC\_DATA\_MSR Bit Descriptions**

Bit	Name	Description
63:0	DC_DATA	<b>Data Cache Data.</b> QWORD data to read from or write to the cache line buffer. The buffer is filled from the cache data array on a read to DC_TAG_MSR (MSR 00001892h) or DC_TAG_I_MSR (MSR 00001893h), and the buffer is written to the cache data array on a write to DC_TAG_MSR or DC_TAG_I_MSR MSRs. The DC_DSEL field in the DC_INDEX_MSR (MSR 00001890h[17:16]) selects which QWORD in the buffer is accessed by DC_DATA, and each access to DC_DATA increments DC_DSEL.

**5.5.2.77 Data Cache Tag MSR (DC\_TAG\_MSR)**

MSR Address 00001892h  
 Type R/W  
 Reset Value 00000000\_00000000h

**DC\_TAG\_MSR Register Map**

63	62	61	60	59	58	57	56	55	54	53	52	51	50	49	48	47	46	45	44	43	42	41	40	39	38	37	36	35	34	33	32
RSVD														LRU																	
31	30	29	28	27	26	25	24	23	22	21	20	19	18	17	16	15	14	13	12	11	10	9	8	7	6	5	4	3	2	1	0
TAG														RSVD												DIRTY	VALID				

**DC\_TAG\_MSR Bit Descriptions**

Bits	Name	Description
63:50	RSVD (RO)	<b>Reserved (Read Only).</b> (Default = 0)

**DC\_TAG\_MSR Bit Descriptions (Continued)**

Bits	Name	Description
49:32	LRU	<p><b>Least Recently Used Value.</b> (Default = 0)</p> <p>Bit 49: Ways 11-8 more recent than ways 15-12.                      Bit 48: Ways 7-4 more recent than ways 15-12.                      Bit 47: Ways 7-4 more recent than ways 11-8.                      Bit 46: Ways 3-0 more recent than ways 15-12.                      Bit 45: Ways 3-0 more recent than ways 11-8.                      Bit 44: Ways 3-0 more recent than ways 7-4.                      Bit 43: Ways 15-14 more recent than ways 13-12.                      Bit 42: Ways 11-10 more recent than ways 9-8.                      Bit 41: Ways 7-6 more recent than ways 5-4.                      Bit 40: Ways 3-2 more recent than ways 1-0.                      Bit 39: Way 15 more recent than way 14.                      Bit 38: Way 13 more recent than way 12.                      Bit 37: Way 11 more recent than way 10.                      Bit 36: Way 9 more recent than way 8.                      Bit 35: Way 7 more recent than way 6.                      Bit 34: Way 5 more recent than way 4.                      Bit 33: Way 3 more recent than way 2.                      Bit 32: Way 1 more recent than way 0.</p> <p>0: False                      1: True</p>
31:12	TAG	<p><b>Tag.</b> Cache Tag Value for line/way selected by DC_INDEX (MSR 00001890h). (Default = 0)</p>
11:2	RSVD (RO)	<p><b>Reserved (Read Only).</b> (Default = 0)</p>
1	DIRTY	<p><b>Dirty.</b> Dirty bit for line/way. (Default = 0)</p> <p>WARNING: Operation is undefined if the Dirty bit is set to 1 and the Valid bit is 0.</p>
0	VALID	<p><b>Valid.</b> Valid bit for the line/way selected by DC_INDEX (MSR 00001890h). (Default = 0)</p>

**5.5.2.78 Data Cache Tag with Increment MSR (DC\_TAG\_I\_MSR)**

MSR Address 00001893h  
 Type R/W  
 Reset Value 00000000\_00000000h

**DC\_TAG\_I\_MSR Register Map**

63	62	61	60	59	58	57	56	55	54	53	52	51	50	49	48	47	46	45	44	43	42	41	40	39	38	37	36	35	34	33	32
RSVD														LRU																	
31	30	29	28	27	26	25	24	23	22	21	20	19	18	17	16	15	14	13	12	11	10	9	8	7	6	5	4	3	2	1	0
TAG														RSVD												DIRTY	VALID				

Bit descriptions for this register are the same as for MSR 00001892h, except read/write of this register causes an auto-increment on DC\_INDEX\_MSR (MSR 00001890h).

**5.5.2.79 Data/Instruction Cache Snoop Register (SNOOP\_MSR)**

MSR Address 00001894h  
 Type WO  
 Reset Value 00000000\_xxxxxxxxh

The SNOOP\_MSR provides a mechanism for injecting a “snoop-for-write” request into the memory subsystem. Both the I and D caches are snooped for the specified physical address. A hit to a dirty line in the D cache results in a writeback followed by the line being invalidated. A hit to a clean line results in only an invalidation. The SNOOP\_MSR is write-only - the read value is undefined. There is no indication as to whether the snoop hit in the caches.

**SNOOP\_MSR Register Map**

63	62	61	60	59	58	57	56	55	54	53	52	51	50	49	48	47	46	45	44	43	42	41	40	39	38	37	36	35	34	33	32
RSVD																															
31	30	29	28	27	26	25	24	23	22	21	20	19	18	17	16	15	14	13	12	11	10	9	8	7	6	5	4	3	2	1	0
SNOOP_ADD																															

**SNOOP\_MSR Bit Descriptions**

Bit	Name	Description
63:32	RSVD	<b>Reserved (Write Only).</b> Write as 0.
31:0	SNOOP_ADD	<b>Cache Snoop Address (Write Only).</b> Physical address to snoop in the caches. A hit to a dirty line results in a writeback followed by an invalidation. A hit to a clean line results in an invalidation only. Both the data and instruction caches are snooped.

**5.5.2.80 L1 Data TLB Index Register (L1DTLB\_INDEX\_MSR)**

MSR Address 00001898h  
 Type R/W  
 Reset Value 00000000\_00000000h

**L1DTLB\_INDEX\_MSR Register Map**

63	62	61	60	59	58	57	56	55	54	53	52	51	50	49	48	47	46	45	44	43	42	41	40	39	38	37	36	35	34	33	32
RSVD																															
31	30	29	28	27	26	25	24	23	22	21	20	19	18	17	16	15	14	13	12	11	10	9	8	7	6	5	4	3	2	1	0
RSVD																												INDEX			

**L1DTLB\_INDEX\_MSR Bit Descriptions**

Bit	Name	Description
63:3	RSVD (RO)	<b>Reserved (Read Only).</b>
2:0	INDEX	<b>L1 Data TLB Index.</b> Index of L1 Data TLB entry to access. Post increments on each access to L1TLB_ENTRY_I_MSR (MSR 0000189Bh).

**5.5.2.81 L1 Data TLB Least Recently Used MSR (L1DTLB\_LRU\_MSR)**

MSR Address 00001899h  
 Type R/W  
 Reset Value 00000000\_00000000h

**L1DTLB\_LRU\_MSR Register Map**

63	62	61	60	59	58	57	56	55	54	53	52	51	50	49	48	47	46	45	44	43	42	41	40	39	38	37	36	35	34	33	32
RSVD																															
31	30	29	28	27	26	25	24	23	22	21	20	19	18	17	16	15	14	13	12	11	10	9	8	7	6	5	4	3	2	1	0
RSVD														LRU																	

**L1DTLB\_LRU\_MSR Bit Descriptions**

Bits	Name	Description
63:18	RSVD (RO)	<b>Reserved (Read Only).</b>
17:0	LRU	<p><b>Least Recently Used Value.</b></p> <p>Bit 17: Entries 8-11 more recent than entries 12-15.                      Bit 16: Entries 4-7 more recent than entries 12-15.                      Bit 15: Entries 4-7 more recent than entries 8-11.                      Bit 14: Entries 0-3 more recent than entries 12-15.                      Bit 13: Entries 0-3 more recent than entries 8-11.                      Bit 12: Entries 0-3 more recent than entries 4-7.                      Bit 11: Entries 12/13 more recent than entries 14/15.                      Bit 10: Entries 8/9 more recent than entries 10/11.                      Bit 9: Entries 4/5 more recent than entries 6/7.                      Bit 8: Entries 0/1 more recent than entries 2/3.                      Bit 7: Entry 14 more recent than entry 15.                      Bit 6: Entry 12 more recent than entry 13.                      Bit 5: Entry 10 more recent than entry 11.                      Bit 4: Entry 8 more recent than entry 9.                      Bit 3: Entry 6 more recent than entry 7.                      Bit 2: Entry 4 more recent than entry 5.                      Bit 1: Entry 2 more recent than entry 3.                      Bit 0: Entry 0 more recent than entry 1.</p> <p>0: False (Default)                      1: True</p>



**5.5.2.82 L1 Data TLB Entry MSR (L1DTLB\_ENTRY\_MSR)**

MSR Address 0000189Ah  
 Type R/W  
 Reset Value 00000000\_00000000h

**L1DTLB\_ENTRY\_MSR Register Map**

63	62	61	60	59	58	57	56	55	54	53	52	51	50	49	48	47	46	45	44	43	42	41	40	39	38	37	36	35	34	33	32
LINADDR														RSVD											WP	WA_WS	WC				
31	30	29	28	27	26	25	24	23	22	21	20	19	18	17	16	15	14	13	12	11	10	9	8	7	6	5	4	3	2	1	0
PHYSADDR														RSVD						DIRTY	ACC	CD	WT_BR	US	WR	VALID					

**L1DTLB\_ENTRY\_MSR Bit Descriptions**

Bit	Name	Description
63:44	LINADDR	<b>Linear Address.</b> Address [32:12].
43:35	RSVD (RO)	<b>Reserved (Read Only).</b>
34	WP	<b>Write-protect Flag.</b> 0: Page can be written. 1: Page is write-protected.
33	WA_WS	<b>Write-allocate/Write-serialize Flag.</b> If the page is cacheable, a 1 indicates the write-allocate flag. If the page is non-cacheable, a 1 indicates the write-serialize flag.
32	WC	<b>Write-combine Flag.</b> When this page is marked as non-cacheable, a 1 indicates that writes may be combined before being sent to the bus.
31:12	PHYSADDR	<b>Physical Address.</b> Address [32:12]
11:7	RSVD (RO)	<b>Reserved (Read Only).</b>
6	DIRTY	<b>Dirty Flag.</b> A 1 indicates that the page has been written to.
5	ACC	<b>Accessed Flag.</b> A 1 indicates an entry in the TLB.
4	CD	<b>Cache Disable Flag.</b> A 1 indicates that the page is uncacheable.
3	WT_BR	<b>Write-through/Write-burst Flag.</b> When the page is cacheable, a 1 indicates that the page is write-through. When the page is non-cacheable, a 1 indicates that the page allows write bursting.
2	US	<b>User Access Privileges.</b> 0: Supervisor. 1: User.
1	WR	<b>Writable Flag.</b> 0: Page can not be written. 1: Page can be written.
0	VALID	<b>Valid Bit.</b> A 1 indicates that the entry in the TLB is valid.

**5.5.2.83 L1 Data TLB Entry with Increment MSR (L1DTLB\_ENTRY\_I\_MSR)**

MSR Address 0000189Bh  
 Type R/W  
 Reset Value 00000000\_00000000h

**L1DTLB\_ENTRY\_I\_MSR Register Map**

63	62	61	60	59	58	57	56	55	54	53	52	51	50	49	48	47	46	45	44	43	42	41	40	39	38	37	36	35	34	33	32
LINADDR														RSVD										WP	WA_WS	WC					
31	30	29	28	27	26	25	24	23	22	21	20	19	18	17	16	15	14	13	12	11	10	9	8	7	6	5	4	3	2	1	0
PHYSADDR														RSVD				DIRTY	ACC	CD	WT_BR	US	WR	VALID							

Bit descriptions for this register are the same as for MSR 0000189Ah, except read/write of this register causes an auto-increment on the L1 TLB\_INDEX\_MSR (MSR 00001898h).

**5.5.2.84 L2 TLB/DTE/PTE Index MSR (L2TLB\_INDEX\_MSR)**

MSR Address 0000189Ch  
 Type R/W  
 Reset Value 00000000\_00000000h

**L2TLB\_INDEX\_MSR Register Map**

63	62	61	60	59	58	57	56	55	54	53	52	51	50	49	48	47	46	45	44	43	42	41	40	39	38	37	36	35	34	33	32
RSVD																															
31	30	29	28	27	26	25	24	23	22	21	20	19	18	17	16	15	14	13	12	11	10	9	8	7	6	5	4	3	2	1	0
RSVD														SEL		RSVD								INDEX			WAY				
RSVD														SEL		RSVD								INDEX			WAY				

**L2TLB\_INDEX\_MSR Bit Descriptions**

Bit	Name	Description
<b>If SEL (bits [17:16]) = 0x</b>		
63:18	RSVD (RO)	<b>Reserved (Read Only).</b> (Default = 0)
17:16	SEL	<b>Select Array to Access.</b> 0x: L2 TLB (64 entries, values 0-63). 10: DTE cache (12 entries, values 0-11). 11: 4M PTE cache (4 entries, values 0-3).
15:6	RSVD (RO)	<b>Reserved (Read Only).</b> (Default = 0)
5:1	INDEX	<b>L2 TLB Index.</b> Post-increments on an access to L2TB_ENTRY_I_MSR (MSR 0000189Fh) if WAY (bit 0) = 1.
0	WAY	<b>Way to Access.</b> Toggles on each access to L2TB_ENTRY_I_MSR (MSR 0000189Fh).
<b>If SEL (bits [17:16]) = 1x</b>		
63:18	RSVD (RO)	<b>Reserved (Read Only).</b> (Default = 0)
17:16	SEL	<b>Select Array to Access.</b> 0x: L2 TLB (64 entries, values 0-63). 10: DTE cache (12 entries, values 0-11). 11: 4M PTE cache (4 entries, values 0-3).

**L2TLB\_INDEX\_MSR Bit Descriptions (Continued)**

Bit	Name	Description
15:6	RSVD (RO)	<b>Reserved (Read Only).</b> (Default = 0)
5:0	INDEX	<b>DTE/PTE Index.</b> Increments on every access to L2TLB_ENTRY_I_MSR (MSR 0000189Fh).

**5.5.2.85 L2 TLB/DTE/PTE Least Recently Used MSR (L2TLB\_LRU\_MSR)**

MSR Address 0000189Dh  
 Type R/W  
 Reset Value 00000000\_00000000h

**L2TLB\_LRU\_MSR Register Map**

63	62	61	60	59	58	57	56	55	54	53	52	51	50	49	48	47	46	45	44	43	42	41	40	39	38	37	36	35	34	33	32
RSVD											DTE_LRU																				
31	30	29	28	27	26	25	24	23	22	21	20	19	18	17	16	15	14	13	12	11	10	9	8	7	6	5	4	3	2	1	0
RSVD											PTE_LRU						RSVD										L2WR1				

**L2TLB\_LRU\_MSR Bit Descriptions**

Bits	Name	Description
63:53	RSVD (RO)	<b>Reserved (Read Only).</b> (Default = 0)
52:32	DTE_LRU	<p><b>DTE Least Recently Used Value.</b></p> <p>Bit 52: DTE entries 0-3 more recent than entries 4-7.                      Bit 51: DTE entries 0-3 more recent than entries 8-11.                      Bit 50: DTE entries 4-7 more recent than entries 8-11.                      Bit 49: DTE entry 8 more recent than entry 9.                      Bit 48: DTE entry 8 more recent than entry 10.                      Bit 47: DTE entry 8 more recent than entry 11.                      Bit 46: DTE entry 9 more recent than entry 10.                      Bit 45: DTE entry 9 more recent than entry 11.                      Bit 44: DTE entry 10 more recent than entry 11.                      Bit 43: DTE entry 4 more recent than entry 5.                      Bit 42: DTE entry 4 more recent than entry 6.                      Bit 41: DTE entry 4 more recent than entry 7.                      Bit 40: DTE entry 5 more recent than entry 6.                      Bit 39: DTE entry 5 more recent than entry 7.                      Bit 38: DTE entry 6 more recent than entry 7.                      Bit 37: DTE entry 0 more recent than entry 1.                      Bit 36: DTE entry 0 more recent than entry 2.                      Bit 35: DTE entry 0 more recent than entry 3.                      Bit 34: DTE entry 1 more recent than entry 2.                      Bit 33: DTE entry 1 more recent than entry 3.                      Bit 32: DTE entry 2 more recent than entry 3.</p> <p>0: False (Default)                      1: True</p>
31:22	RSVD (RO)	<b>Reserved (Read Only).</b> (Default = 0)

**L2TLB\_LRU\_MSR Bit Descriptions (Continued)**

Bits	Name	Description
21:16	PTE_LRU	<b>4M PTE Least Recently Used Value.</b> Bit 21: 4M PTE entry 0 more recent than entry 1. Bit 20: 4M PTE entry 0 more recent than entry 2. Bit 19: 4M PTE entry 0 more recent than entry 3. Bit 18: 4M PTE entry 1 more recent than entry 2. Bit 17: 4M PTE entry 1 more recent than entry 3. Bit 16: 4M PTE entry 2 more recent than entry 3.  0: False (Default) 1: True
15:1	RSVD (RO)	<b>Reserved (Read Only).</b> (Default = 0)
0	L2WR1	<b>L2 Write to Way 1.</b> Next L2 TLB write to way 1 if both ways are valid. (Default = 0)

**5.5.2.86 L2 TLB/DTE/PTE Entry MSR (L2TLB\_ENTRY\_MSR)**

MSR Address 0000189Eh  
 Type R/W  
 Reset Value 00000000\_00000000h

**L2TLB\_ENTRY\_MSR Register Map**

63	62	61	60	59	58	57	56	55	54	53	52	51	50	49	48	47	46	45	44	43	42	41	40	39	38	37	36	35	34	33	32		
LINADDR														RSVD										WP	WA_WS	WC							
LINADDR														RSVD																			
31	30	29	28	27	26	25	24	23	22	21	20	19	18	17	16	15	14	13	12	11	10	9	8	7	6	5	4	3	2	1	0		
PHYSADDR														RSVD										GLOBAL	4MPTE	DIRTY	ACC	CD	WT	IWT_BR	US	WR	VALID

**L2TLB\_ENTRY\_MSR Bit Descriptions**

Bit	Name	Description
<b>If SEL bits in L2TLB_INDEX MSR = 0x (MSR 0000189Ch[17:16] = 0x)</b>		
63:44	LINADDR	<b>Linear Address.</b> Address [32:12].
43:35	RSVD (RO)	<b>Reserved (Read Only).</b>
34	WP	<b>Write-protect Flag.</b> 0: Page can be written. 1: Page is write-protected.
33	WA_WS	<b>Write-allocate/Write-serialize Flag.</b> If the page is cacheable, a 1 indicates the write-allocate flag. If the page is non-cacheable, a 1 indicates the write-serialize flag.
32	WC	<b>Write-combine Flag.</b> When this page is marked as non-cacheable, a 1 indicates that writes may be combined before being sent to the bus.
31:12	PHYSADDR	<b>Physical Address.</b> Address [32:12]
11:9	RSVD (RO)	<b>Reserved (Read Only).</b>
8	GLOBAL	<b>Global Page Flag.</b> A 1 indicates a global page.

**L2TLB\_ENTRY\_MSR Bit Descriptions (Continued)**

Bit	Name	Description
7	RSVD (RO)	<b>Reserved (Read Only).</b>
6	DIRTY	<b>Dirty Flag.</b> A 1 indicates that the page has been written to.
5	ACC	<b>Accessed Flag.</b> A 1 indicates an entry in the TLB.
4	CD	<b>Cache Disable Flag.</b> A 1 indicates that the page is uncacheable.
3	WT_BR	<b>Write-Through/Write Burst Flag.</b> When the page is cacheable, a 1 indicates that the page is write-through. When the page is non-cacheable, a 1 indicates that the page allows write bursting.
2	US	<b>User Access Privileges.</b> 0: Supervisor. 1: User.
1	WR	<b>Writable Flag.</b> 0: Page can not be written. 1: Page can be written.
0	VALID	<b>Valid Bit.</b> A 1 indicates that the entry in the TLB is valid.
<b>If SEL bits in L2TLB_INDEX MSR = 1x (MSR 0000189Ch[17:16] = 1x)</b>		
63:44	LINADDR	<b>Linear Address.</b> Address [32:22].
53:32	RSVD (RO)	<b>Reserved (Read Only).</b>
31:12	PHYSADDR	<b>Physical Address.</b> Address [32:12]
11:9	RSVD (RO)	<b>Reserved (Read Only).</b>
8	GLOBAL	<b>Global Page Flag.</b> A 1 indicates a global page.
7	4MPTE	<b>4M PTE Flag.</b> 0: DTE access. 1: 4M PTE access.
6	DIRTY	<b>Dirty Flag.</b> A 1 indicates that the page has been written to.
5	ACC	<b>Accessed Flag.</b> A 1 indicates an entry in the TLB.
4	CD	<b>Cache Disable Flag.</b> A 1 indicates that the page is uncacheable.
3	WT	<b>Write-through Flag.</b> A 1 indicates that the page is write-through.
2	US	<b>User Access Privileges.</b> 0: Supervisor. 1: User.
1	WR	<b>Writable Flag.</b> 0: Page can not be written. 1: Page can be written.
0	VALID	<b>Valid Bit.</b> A 1 indicates that the entry in the TLB is valid.

**5.5.2.87 L2 TLB/DTE/PTE Entry with Increment MSR (L2TLB\_ENTRY\_I\_MSR)**

MSR Address 0000189Fh  
 Type R/W  
 Reset Value 00000000\_00000000h

**L2TLB\_ENTRY\_I\_MSR Register Map**

63	62	61	60	59	58	57	56	55	54	53	52	51	50	49	48	47	46	45	44	43	42	41	40	39	38	37	36	35	34	33	32
LINADDR																RSVD											WP	WA_WS	WC		
31	30	29	28	27	26	25	24	23	22	21	20	19	18	17	16	15	14	13	12	11	10	9	8	7	6	5	4	3	2	1	0
PHYSADDR																RSVD						GLOBAL	RSVD	DIRTY	ACC	CD	WT_BR	US	WR	VALID	

Bit descriptions for this register are the same as for MSR 0000189Eh, except read/write of this register causes an auto-increment on the L2TLB\_INDEX\_MSR (MSR 0000189Ch).

**5.5.2.88 Data Memory Subsystem Built-In Self-Test MSR (DM\_BIST\_MSR)**

MSR Address 000018C0h  
 Type R/W  
 Reset Value 00000000\_00000000h

**DM\_BIST\_MSR Register Map**

63	62	61	60	59	58	57	56	55	54	53	52	51	50	49	48	47	46	45	44	43	42	41	40	39	38	37	36	35	34	33	32
TAGCMP															TAGDAT																
31	30	29	28	27	26	25	24	23	22	21	20	19	18	17	16	15	14	13	12	11	10	9	8	7	6	5	4	3	2	1	0
TLBCMP	TLBDAT	DATA					RSVD											RETEN_TLB	RUN_TLB	RETEN_DATA	RUN_DATA	RETEN_TAG	RUN_TAG								

**DM\_BIST\_MSR Bit Descriptions**

Bits	Name	Description
63:48	TAGCMP[15:0] (RO)	<b>Cache Tag Comparators (Read Only).</b> BIST results for cache tag comparators (array15...array0). 0: Fail. 1: Pass.
47:32	TAGDAT[15:0] (RO)	<b>Cache Tag Data (Read Only).</b> BIST results for cache tag data integrity (array15...array0). 0: Fail. 1: Pass.
31:30	TLBCMP[1:0] (RO)	<b>L2 TLB Comparators (Read Only).</b> BIST results for L2 TLB comparators (array1, array0). 0: Fail. 1: Pass.
29:28	TLBDAT[1:0] (RO)	<b>L2 TLB Data (Read Only).</b> BIST results for L2 TLB data integrity (array1, array0). 0: Fail. 1: Pass.
27:24	DATA[3:0] (RO)	<b>Data Cache Data (Read Only).</b> BIST results for data cache data arrays[3:0]. 0: Fail. 1: Pass.
23:6	RSVD (RO)	<b>Reserved (Read Only).</b> Read as 0.

## DM\_BIST\_MSR Bit Descriptions

Bits	Name	Description
5	RETEN_TLB	<b>L2 TLB Retention Timer.</b> Enable retention timer for L2 TLB BIST. 0: Disable. 1: Enable.
4	RUN_TLB	<b>L2 TLB Run.</b> Start BIST test on L2 TLB arrays. Should read as 0 because BIST will have completed before the MSR read can start.
3	RETEN_DATA	<b>Cache Data Retention Timer.</b> Enable retention timer for cache data array BIST. 0: Disable. 1: Enable.
2	RUN_DATA	<b>Cache Data Run.</b> Start BIST test on cache data array. Should read as 0 because BIST will have completed before the MSR read can start.
1	RETEN_TAG	<b>Cache Tag Retention Timer.</b> Enable retention timer for cache tag array BIST. 0: Disable. 1: Enable.
0	RUN_TAG	<b>Cache Tag Run.</b> Start BIST test on cache tag arrays. Should read as 0 because BIST will have completed before the MSR read can start.

## 5.5.2.89 Bus Controller Configuration 0 MSR (BC\_CONFIG0\_MSR)

MSR Address 00001900h  
 Type R/W  
 Reset Value 00000000\_00000111h

## BC\_CONFIG0\_MSR Register Map

63	62	61	60	59	58	57	56	55	54	53	52	51	50	49	48	47	46	45	44	43	42	41	40	39	38	37	36	35	34	33	32														
RSVD																																													
31	30	29	28	27	26	25	24	23	22	21	20	19	18	17	16	15	14	13	12	11	10	9	8	7	6	5	4	3	2	1	0														
RSVD				PAUSEDLY				RSVD				GPF_X				RSVD				CLK_ONS		SUSP		RSVD				RTSC_SUSP		RSVD		TSC_DMM		TSC_SUSP		TSC_SMM		RSVD				ISNINV		SNOOP	

## BC\_CONFIG0\_MSR Bit Descriptions

Bit	Name	Description
63:28	RSVD	<b>Reserved.</b> Write as read.
27:24	PAUSEDLY	<b>Pause Delay.</b> This field sets the number of clocks for which the bus controller will attempt to suspend the CPU when a PAUSE instruction is executed. The approximate number of clocks is PAUSEDLY*8. NOTE that the actual number of clocks that the CPU is suspended will differ from this value, and will vary from pause to pause due to the overhead of the suspend/unsuspend mechanism and any other CPU activity that would affect how it responds to suspend requests.  Note also that bit 1 of MSR 00001210h must be set in order for suspend on pause to be enabled.
23:21	RSVD	<b>Reserved.</b>
20	GPF_X	<b>General Protection Faults on EXCEPT Flags.</b> Generate general protection faults on MSR accesses whose response packets have the EXCEPT flag set. 0: Disable. 1: Enable.

**BC\_CONFIG0\_MSR Bit Descriptions (Continued)**

Bit	Name	Description
19:14	RSVD	<b>Reserved.</b> Write as read.
13	CLK_ONS	<b>CPU Core Clocks On during Suspend.</b> 0: All CPU Core clocks off during Suspend. (Default) 1: All CPU Core clocks on during Suspend.
12	SUSP	<b>Suspend Active.</b> Enable Suspend input. 0: Ignore Suspend input. (Default) 1: Enable Suspend input.
11:9	RSVD	<b>Reserved.</b> Write as read.
8	RTSC_SUSP	<b>Real Time Stamp Counter Counts during Suspend.</b> 0: Disable. 1: Enable. (Default)
7	RSVD	<b>Reserved.</b> Write as read.
6	TSC_DMM	<b>Time Stamp Counter Counts during DMM.</b> 0: Disable. (Default) 1: Enable.
5	TSC_SUSP	<b>Time Stamp Counter Counts during Suspend.</b> 0: Disable. (Default) 1: Enable.
4	TSC_SMM	<b>Time Stamp Counter Counts during SMM.</b> 0: Disable. 1: Enable. (Default)
3:2	RSVD	<b>Reserved.</b> Write as read.
1	ISNINV	<b>Ignore Snoop Invalidate.</b> Allow the CPU Core to ignore the INVALIDATE bit in the GLIU snoop packet. When a snoop hits to a dirty cache line it is evicted, regardless of the state of the INVALIDATE bit in the GLIU packet. 0: Process snoop packet. 1: Ignore snoop packet. (Default)
0	SNOOP	<b>Instruction Memory (IM) to Data Memory (DM) Snooping.</b> Allow code fetch snoops from the IM to the DM cache. 0: Disable. 1: Enable. (Default)

**5.5.2.90 Bus Controller Configuration 1 MSR (BC\_CONFIG1\_MSR)**

MSR Address      00001901h  
Type              R/W  
Reset Value      00000000\_00000000h

This register is reserved. Write as read.



**5.5.2.91 Reserved Status MSR (RSVD\_STS\_MSR)**

MSR Address 00001904h  
 Type RO  
 Reset Value 00000000\_00000000h

**RSVD\_STS\_MSR Bit Descriptions**

Bit	Name	Description
63:0	RSVD (RO)	<b>Reserved (Read Only).</b> Reads back as 0.

**5.5.2.92 MSR Lock MSR (MSR\_LOCK\_MSR)**

MSR Address 00001908h  
 Type R/W  
 Reset Value 00000000\_00000000h

**MSR\_LOCK\_MSR Register Map**

63	62	61	60	59	58	57	56	55	54	53	52	51	50	49	48	47	46	45	44	43	42	41	40	39	38	37	36	35	34	33	32
RSVD																															
31	30	29	28	27	26	25	24	23	22	21	20	19	18	17	16	15	14	13	12	11	10	9	8	7	6	5	4	3	2	1	0
RSVD																															MSR_LOCK

**MSR\_LOCK\_MSR Bit Descriptions**

Bit	Name	Description
63:1	RSVD	<b>Reserved.</b> Write as read
0	MSR_LOCK	<p><b>Lock MSRs.</b> The CPU Core MSRs above 0xFFFF (with the exception of the MSR_LOCK register itself) are locked when this bit reads back as 1. To unlock these MSRs, write the value 45524F434C494156h to this register. Writing any other value locks the MSRs.</p> <p>The lock only affects software access via the WRMSR and RDMSR instructions when the processor is NOT in SMM or DMM mode. MSRs are always writable and readable from the GLBus and when the processor is in SMM or DMM mode regardless of the state of the LOCK bit.</p> <p>Note that a write or read to a locked MSR register causes a protection exception in the pipeline.</p> <p>When MSRs are locked, no GLBus MSR transactions are generated (GLBus MSR addresses are above 3FFFh).</p>

**5.5.2.93 Real Time Stamp Counter MSR (RTSC\_MSR)**

MSR Address 00001910h  
 Type R/W  
 Reset Value 00000000\_00000000h

**RTSC\_MSR Register Map**

63	62	61	60	59	58	57	56	55	54	53	52	51	50	49	48	47	46	45	44	43	42	41	40	39	38	37	36	35	34	33	32
RTSC (High DWORD)																															
31	30	29	28	27	26	25	24	23	22	21	20	19	18	17	16	15	14	13	12	11	10	9	8	7	6	5	4	3	2	1	0
RTSC (Low DWORD)																															

**RTSC\_MSR Bit Descriptions**

Bit	Name	Description
63:0	RTSC	<b>Real Time Stamp Counter.</b> This register is the 64-bit secondary, or “real” time stamp counter. This counter allows software to configure the TSC not to include SMM or DMM time, and still have an accurate real time measurement that includes these times.  BC_CONFIG0_MSR (MSR 00001900h) contains configuration bits that determine if the RTSC counts during Suspend mode. It always counts during SMM and DMM modes.  All bits in this register are writable, unlike the TSC that clears the upper DWORD to 0 on writes.

**5.5.2.94 TSC and RTSC Low DWORDs MSR (RTSC\_TSC\_MSR)**

MSR Address 00001911h  
 Type RO  
 Reset Value 00000000\_00000000h

**RTSC\_TSC\_MSR Register Map**

63	62	61	60	59	58	57	56	55	54	53	52	51	50	49	48	47	46	45	44	43	42	41	40	39	38	37	36	35	34	33	32
RTSC_LOW																															
31	30	29	28	27	26	25	24	23	22	21	20	19	18	17	16	15	14	13	12	11	10	9	8	7	6	5	4	3	2	1	0
TSC_LOW																															

**RTSC\_TSC\_MSR Bit Descriptions**

Bit	Name	Description
63:32	RTSC_LOW	<b>Real Time Stamp Counter Low DWORD.</b> This field provides a synchronized snapshot of the low DWORD of the RTSC register (MSR 00001910h).
31:0	TSC_LOW	<b>Time Stamp Counter Low DWORD.</b> This field provides a synchronized snapshot of the low DWORD of the TSC register (MSR 00000010h).

**5.5.2.95 L2 Cache Configuration MSR (L2\_CONFIG\_MSR)**

MSR Address 00001920h  
 Type R/W  
 Reset Value 00000000\_0000000Eh

L2\_CONFIG\_MSR controls the behavior of the L2 cache.

**L2\_CONFIG\_MSR Register Map**

63	62	61	60	59	58	57	56	55	54	53	52	51	50	49	48	47	46	45	44	43	42	41	40	39	38	37	36	35	34	33	32	
RSVD																																
31	30	29	28	27	26	25	24	23	22	21	20	19	18	17	16	15	14	13	12	11	10	9	8	7	6	5	4	3	2	1	0	
RSVD								L2_IM_LOCK				L2_DM_LOCK				RSVD								L2_TAG_CLKGT_EN	L2_PASS_IOMSR	L2_DMEVCT_DIRTY	L2_WAIT_DM_WR	L2_INVALID	L2_IM_ALLOC_EN	L2_DM_ALLOC_EN	L2_ALLOC_EN	L2_EN

**L2\_CONFIG\_MSR Bit Descriptions**

Bit	Name	Description
63:24	RSVD	<b>Reserved.</b>
23:20	L2_IM_LOCK	<b>L2 Instruction Memory Subsystem Lock.</b> On allocations from the IM, avoid using the ways that have the corresponding bits set to 1. (Default = 0)
19:16	L2_DM_LOCK	<b>L2 Cache Data Memory Subsystem Lock.</b> On allocations from the DM, avoid using the ways that have the corresponding bits set to 1. (Default = 0)
15:9	RSVD	<b>Reserved.</b>
8	L2_TAG_CLKGT_EN	<b>L2 Cache Tag Clock Gating Enable.</b> If set, the L2 tags would be clocked only when accessed. Otherwise, the tags would be clocked whenever the bus controller clocks are active. (Default = 0)
7	L2_PASS_IOMSR	<b>L2 Cache (always) Pass I/Os and MSRs.</b> Reserved for Debug only. Pass I/Os and MSRs through regardless of the state of the L2. (Default = 0)
6	L2_DMEVCT_DIRTY	<b>L2 Cache Data Memory Subsystem Evictions (always) Dirty.</b> Reserved for Debug only. Treats all DM evictions as dirty. (Default = 0)
5	L2_WAIT_DM_WR	<b>L2 Cache Wait for Data Memory Subsystem Writes.</b> Reserved for debug only. Waits for all data beats from DM before proceeding. (Default = 0)
4	L2_INVALID	<b>L2 Cache Invalidate.</b> Invalidate the entire contents of the L2 cache. This bit always reads back as 0. (Default = 0)
3	L2_IM_ALLOC_EN	<b>L2 Cache Instruction Memory Subsystem Allocation Enable.</b> A new IM access is allocated into the L2 cache only if this bit is on. (Default = 1)
2	L2_DM_ALLOC_EN	<b>L2 Cache Data Memory Subsystem Allocation Enable.</b> A new DM access is allocated into the L2 cache only if this bit is on. (Default = 1)
1	L2_ALLOC_EN	<b>L2 Cache Allocation Enable.</b> A new line is allocated into the L2 cache only if this bit is on (Default = 1)
0	L2_EN	<b>L2 Cache Enable.</b> If this bit is on, the arbiter redirects memory accesses to the L2 block. (Default = 0)

**5.5.2.96 L2 Cache Status MSR (L2\_STATUS\_MSR)**

MSR Address 00001921h  
 Type RO  
 Reset Value 00000000\_00000001h

L2\_STATUS\_MSR returns the status of the L2 cache controller.

**L2\_STATUS\_MSR Register Map**

63	62	61	60	59	58	57	56	55	54	53	52	51	50	49	48	47	46	45	44	43	42	41	40	39	38	37	36	35	34	33	32
RSVD																															
31	30	29	28	27	26	25	24	23	22	21	20	19	18	17	16	15	14	13	12	11	10	9	8	7	6	5	4	3	2	1	0
RSVD																															L2_IDLE

**L2\_STATUS\_MSR Bit Descriptions**

Bit	Name	Description
63:1	RSVD	Reserved.
0	L2_IDLE	L2 Cache Idle. Returns 1 if the L2 cache controller is idle. (Default = 1)

**5.5.2.97 L2 Cache Index MSR (L2\_INDEX\_MSR)**

MSR Address 00001922h  
 Type R/W  
 Reset Value 00000000\_00000000h

L2\_INDEX\_MSR has the L2 cache index, the way and the data QWORD select for diagnostic accesses.

**L2\_INDEX\_MSR Register Map**

63	62	61	60	59	58	57	56	55	54	53	52	51	50	49	48	47	46	45	44	43	42	41	40	39	38	37	36	35	34	33	32
RSVD																															
31	30	29	28	27	26	25	24	23	22	21	20	19	18	17	16	15	14	13	12	11	10	9	8	7	6	5	4	3	2	1	0
RSVD															L2_DSEL	RSVD	L2_INDEX							RSVD	L2_WAY						

**L2\_INDEX\_MSR Bit Descriptions**

Bit	Name	Description
63:18	RSVD	Reserved. (Default = 0)
17:16	L2_DSEL	L2 Cache Data QWORD Select. (Default = 0)
15	RSVD	Reserved. (Default = 0)
14:5	L2_INDEX	L2 Cache Index for Diagnostics Accesses. (Default = 0)
4:2	RSVD	Reserved. (Default = 0)
1:0	L2_WAY	L2 Cache Way Selected for Diagnostics Accesses. (Default = 0)

**5.5.2.98 L2 Cache Data MSR (L2\_DATA\_MSR)**

MSR Address 00001923h  
 Type R/W  
 Reset Value 00000000\_00000000h

L2\_DATA\_MSR is used to access the L2 cache data for diagnostic accesses.

**L2\_DATA\_MSR Register Map**

63	62	61	60	59	58	57	56	55	54	53	52	51	50	49	48	47	46	45	44	43	42	41	40	39	38	37	36	35	34	33	32
L2_DATA (High DWORD)																															
31	30	29	28	27	26	25	24	23	22	21	20	19	18	17	16	15	14	13	12	11	10	9	8	7	6	5	4	3	2	1	0
L2_DATA (Low DWORD)																															

**L2\_DATA\_MSR Bit Descriptions**

Bit	Name	Description
63:0	L2_DATA	<b>L2 Cache Array Data.</b> (Default = 0)

**5.5.2.99 L2 Cache Tag MSR (L2\_TAG\_MSR)**

MSR Address 00001924h  
 Type R/W  
 Reset Value 00000000\_00000000h

L2\_TAG\_MSR has the L2 cache tag, MRU and valid bits for diagnostic accesses.

**L2\_TAG\_MSR Register Map**

63	62	61	60	59	58	57	56	55	54	53	52	51	50	49	48	47	46	45	44	43	42	41	40	39	38	37	36	35	34	33	32
RSVD																															
31	30	29	28	27	26	25	24	23	22	21	20	19	18	17	16	15	14	13	12	11	10	9	8	7	6	5	4	3	2	1	0
L2_TAG														RSVD										L2_MRU_2	L2_MRU_1	L2_MRU_0	RSVD	L2_VALID			

**L2\_TAG\_MSR Bit Descriptions**

Bit	Name	Description
63:32	RSVD	<b>Reserved.</b> (Default = 0)
31:15	L2_TAG	<b>L2 Cache Tag.</b> Tag entry of the current way. (Default = 0)
14:7	RSVD	<b>Reserved.</b> (Default = 0)
6	L2_MRU_2	<b>L2 Cache 2 Most Recently Used.</b> MRU bit for the current index. If equal to 1, ways 3-2 more recent than ways 1-0. (Default = 0)
5	L2_MRU_1	<b>L2 Cache 1 Most Recently Used.</b> MRU bit for the current index. If equal to 1, way 3 more recent than way 2. (Default = 0)
4	L2_MRU_0	<b>L2 Cache 0 Most Recently Used.</b> MRU bit for the current index. If equal to 1, way 1 more recent than way 0. (Default = 0)
3:1	RSVD	<b>Reserved.</b> (Default = 0)
0	L2_VALID	<b>L2 Cache Valid.</b> Valid bit for the current way. 0: Invalid. (Default) 1: Valid.

**5.5.2.100 L2 Cache Tag with Increment MSR (L2\_TAG\_I\_MSR)**

MSR Address 00001925h  
 Type R/W  
 Reset Value 00000000\_00000000h

The L2\_TAG\_I\_MSR has the auto incremented L2 cache tag, MRU and valid bits for diagnostic accesses.

**L2\_TAG\_I\_MSR Register Map**

63	62	61	60	59	58	57	56	55	54	53	52	51	50	49	48	47	46	45	44	43	42	41	40	39	38	37	36	35	34	33	32
RSVD																															
31	30	29	28	27	26	25	24	23	22	21	20	19	18	17	16	15	14	13	12	11	10	9	8	7	6	5	4	3	2	1	0
L2_TAG																RSVD							L2_MRU			RSVD			L2_VALID		

Bit descriptions for this register are the same as for L2\_TAG\_MSR (MSR 00001924h), except read/write of this register causes an auto increment on the L2\_INDEX\_MSR (MSR 00001922h).

**5.5.2.101 L2 Cache Built-In Self-Test MSR (L2\_BIST\_MSR)**

MSR Address 00001926h  
 Type R/W  
 Reset Value 00000000\_00000000h

L2\_BIST\_MSR has the L2 cache index for diagnostic accesses.

**L2\_BIST\_MSR Register Map**

63	62	61	60	59	58	57	56	55	54	53	52	51	50	49	48	47	46	45	44	43	42	41	40	39	38	37	36	35	34	33	32
RSVD																															
31	30	29	28	27	26	25	24	23	22	21	20	19	18	17	16	15	14	13	12	11	10	9	8	7	6	5	4	3	2	1	0
RSVD		BIST_MRU_GO	BIST_DATA_CMP_STAT													BIST_DATA_GO	BIST_TAG_GO_CMP	BIST_TAG_GO_WAY3	BIST_TAG_GO_WAY2	BIST_TAG_GO_WAY1	BIST_TAG_GO_WAY0	BIST_TAG_GO	BIST_MRU_DRT_EN	BIST_MRU_EN	BIST_DATA_DRT_EN	BIST_DATA_EN	BIST_TAG_DRT_EN	BIST_TAG_EN			

**L2\_BIST\_MSR Bit Descriptions**

Bit	Name	Description
63:30	RSVD (RO)	<b>Reserved (Read Only).</b> (Default = 0)
29	BIST_MRU_GO (RO)	<b>L2 Cache Most Recently Used BIST Result (Read Only).</b> 0: Fail. (Default) 1: Pass.
28:13	BIST_DATA_CMP_STAT (RO)	<b>L2 Cache Data BIST Result (Read Only).</b> One for each passed comparator - 16 total. (Default = 0)
12	BIST_DATA_GO (RO)	<b>L2 Cache Data BIST Result (Read Only).</b> 0: Fail. (Default) 1: Pass.
11	BIST_TAG_GO_CMP (RO)	<b>L2 Cache Tag Comparator BIST Result (Read Only).</b> 0: Fail. (Default) 1: Pass.

**L2\_BIST\_MSR Bit Descriptions (Continued)**

Bit	Name	Description
10	BIST_TAG_GO_WAY3 (RO)	<b>L2 Cache Tag BIST Way 3 Result (Read Only).</b> 0: Fail. (Default) 1: Pass.
9	BIST_TAG_GO_WAY2 (RO)	<b>L2 Cache Tag BIST Way 2 Result (Read Only).</b> 0: Fail. (Default) 1: Pass.
8	BIST_TAG_GO_WAY1 (RO)	<b>L2 Cache Tag BIST Way 1 Result (Read Only).</b> 0: Fail. (Default) 1: Pass.
7	BIST_TAG_GO_WAY0 (RO)	<b>L2 Cache Tag BIST Way 0 Result (Read Only).</b> 0: Fail. (Default) 1: Pass.
6	BIST_TAG_GO (RO)	<b>L2 Cache Tag BIST Result (Read Only).</b> 0: Fail. (Default) 1: Pass.
5	BIST_MRU_DRT_EN	<b>L2 Cache Most Recently Used Data Retention Timer BIST Enable.</b> Enable the data retention timer for the MRU BIST. 0: Disable. (Default) 1: Enable
4	BIST_MRU_EN	<b>L2 Cache Most Recently Used BIST Enable.</b> Start MRU BIST (on a write). 0: Disable. (Default) 1: Enable
3	BIST_DATA_DRT_EN	<b>L2 Cache Data Retention Timer BIST Enable.</b> Enable data retention timer for the data BIST. 0: Disable. (Default) 1: Enable
2	BIST_DATA_EN	<b>L2 Cache Data BIST Enable.</b> Start data BIST (on a write). 0: Don't start BIST. (Default) 1: Start BIST
1	BIST_TAG_DRT_EN	<b>L2 Cache Tag Data Retention Timer BIST Enable.</b> Enable Data Retention timer for the Tag BIST. 0: Disable. (Default) 1: Enable
0	BIST_TAG_EN	<b>L2 Cache Tag BIST Enable.</b> Start Tag BIST (on a write). 0: Don't start BIST. (Default) 1: Start BIST

**5.5.2.102 L2 Cache Treatment Control MSR (L2\_TRTMNT\_CTL\_MSR)**

MSR Address 00001927h  
 Type R/W  
 Reset Value 00000000\_00000000h

**L2\_TRTMNT\_CTL\_MSR Register Map**

63	62	61	60	59	58	57	56	55	54	53	52	51	50	49	48	47	46	45	44	43	42	41	40	39	38	37	36	35	34	33	32
RSVD																															
31	30	29	28	27	26	25	24	23	22	21	20	19	18	17	16	15	14	13	12	11	10	9	8	7	6	5	4	3	2	1	0
RSVD													TAG_ST_RST_CODE	RSVD	IMEVCT_INVAL_CODE			RSVD	L2_INVAL_CODE			RSVD						TAG_ST_RST_EN	IMEVCT_INVAL_EN	L2_INVAL_EN	

**L2\_TRTMNT\_CTL\_MSR Bit Descriptions**

Bit	Name	Description
63:19	RSVD	<b>Reserved.</b>
18:16	TAG_ST_RST_CODE	<b>L2 Cache Tag State Machine Reset Code.</b> If TAG_ST_RST_ENA (bit 2) is set, the code on the treatment bus forces the tag state machine to reset. (Caution: Extremely destructive - use only to poke around on hard hangs.) (Default = 0)
15	RSVD	<b>Reserved.</b>
14:12	IMEVCT_INVAL_CODE	<b>Instruction Memory Subsystem Eviction Invalidate Code.</b> If IMEVCT_INVAL_ENA (bit 1) is set, the code on the treatment bus forces invalidation of the IM eviction buffer. (Default = 0)
11	RSVD	<b>Reserved.</b>
10:8	L2_INVAL_CODE	<b>L2 Cache Invalidate Code.</b> If L2_INVAL_ENA (bit 0) is set, the code on the treatment bus forces invalidation of the L2 cache. (Default = 0)
7:3	RSVD	<b>Reserved.</b>
2	TAG_ST_RST_EN	<b>L2 Cache Tag State Machine Reset Enable.</b> Allows tag state machine reset through the treatment bus. 0: Disable. (Default) 1: Enable.
1	IMEVCT_INVAL_EN	<b>Instruction Memory Subsystem Eviction Invalidate Enable.</b> Allows IM eviction buffer invalidation through the treatment bus. 0: Disable. (Default) 1: Enable.
0	L2_INVAL_EN	<b>L2 Cache Invalidate Enable.</b> Allows L2 cache invalidation through the treatment bus. 0: Disable. (Default) 1: Enable.



**5.5.2.103 Power Mode MSR (PMODE\_MSR)**

MSR Address 00001930h  
 Type R/W  
 Reset Value 00000000\_00000300h

This MSR enables some modules to turn their clocks off when they are idle to save power. Most of these bits are off by default. It is recommended that they be set by BIOS.

**PMODE\_MSR Register Map**

63	62	61	60	59	58	57	56	55	54	53	52	51	50	49	48	47	46	45	44	43	42	41	40	39	38	37	36	35	34	33	32				
RSVD																																			
31	30	29	28	27	26	25	24	23	22	21	20	19	18	17	16	15	14	13	12	11	10	9	8	7	6	5	4	3	2	1	0				
RSVD													IRS_IF	IRS_IMTAG	IRS_IMDATA	RSVD										FPU_EX	FPU_FP	RSVD						BCL2_MSR	BCL2_GATED

**PMODE\_MSR Bit Descriptions**

Bit	Name	Description
63:19	RSVD	<b>Reserved.</b>
18	IRS_IF	<b>Reserved, Instruction Fetch.</b> Reserved for possible future clock gating of IF. (Default = 0)
17	IRS_IMTAG	<b>Reserved, Instruction Memory Subsystem.</b> Reserved for possible future clock gating IM tag. (Default = 0)
16	IRS_IMDATA	<b>Instruction Memory Subsystem Data.</b> When bit is set, IM may turn off the clock when IM_DATA is idle. (Default = 0)
9	FPU_EX	<b>FPU EX.</b> When bit is set, FPU may turn off the clock to FPU Region 1 when FP_EX is idle. (Default = 1)
8	FPU_FP	<b>FPU FP.</b> When bit is set, FPU may turn off the clock to FPU Region 2 when FPU is idle. (Default = 1)
1	BCL2_MSR	<b>BCL2 MSR.</b> When bit is set, BCL2 may turn off the clock to BC Region 1 when BCL2_MSR is idle. (Default = 0)
0	BCL2_GATED	<b>BCL2 Gated.</b> When bit is set, BCL2 may turn off the clock to BC Region 2 when BCL2 is idle. (Default = 0)

**5.5.2.104 Bus Controller Extended Debug Registers 1 and 0 MSR (BXDR1\_BXDR0\_MSR)**

MSR Address 00001950h  
 Type R/W  
 Reset Value 00000000\_00000000h

**BXDR1\_BXDR0\_MSR Register Map**

63	62	61	60	59	58	57	56	55	54	53	52	51	50	49	48	47	46	45	44	43	42	41	40	39	38	37	36	35	34	33	32
BXDR1_PHYS_ADDR																															
31	30	29	28	27	26	25	24	23	22	21	20	19	18	17	16	15	14	13	12	11	10	9	8	7	6	5	4	3	2	1	0
BXDR0_PHYS_ADDR																															

**BXDR1\_BXDR0\_MSR Bit Descriptions**

Bit	Name	Description
63:32	BXDR1_PHYS_ADDR	<b>Address Match Value for BXDR1.</b> This field specifies addresses that must match the physical address currently in the bus controller in order to trigger the extended breakpoint. (Default = 0)
31:0	BXDR0_PHYS_ADDR	<b>Address Match Value for BXDR0.</b> This field specifies addresses that must match the physical address currently in the bus controller in order to trigger the extended breakpoint. (Default = 0)

**5.5.2.105 Bus Controller Extended Debug Registers 3 and 2 MSR (BXDR3\_BXDR2\_MSR)**

MSR Address 00001951h  
 Type R/W  
 Reset Value 00000000\_00000000h

**BXDR3\_BXDR2\_MSR Register Map**

63	62	61	60	59	58	57	56	55	54	53	52	51	50	49	48	47	46	45	44	43	42	41	40	39	38	37	36	35	34	33	32
BXDR3_PHYS_ADDR																															
31	30	29	28	27	26	25	24	23	22	21	20	19	18	17	16	15	14	13	12	11	10	9	8	7	6	5	4	3	2	1	0
BXDR2_PHYS_ADDR																															

**BXDR3\_BXDR2\_MSR Bit Descriptions**

Bit	Name	Description
63:32	BXDR3_PHYS_ADDR	<b>Address Match Value for BXDR3.</b> This field specifies addresses that must match the physical address currently in the bus controller in order to trigger the extended breakpoint. (Default = 0)
31:0	BXDR2_PHYS_ADDR	<b>Address Match Value for BXDR2.</b> This field specifies addresses that must match the physical address currently in the bus controller in order to trigger the extended breakpoint. (Default = 0)

**5.5.2.106 Bus Controller Extended Debug Registers 6 and 7 MSR (BXDR6\_BXDR7\_MSR)**

MSR Address 00001953h  
 Type R/W  
 Reset Value 00000000\_00000000h

BXDR6 (bits [31:0]) contains the status of the extended bus controller breakpoints. When a breakpoint occurs, the corresponding status bit is set in this register. The status bits remain set until cleared by an MSR write.

BXDR7 (bits [63:32]) is used to enable and specify the type of BXDR0-BXDR3. BXDR7 is also used to specify the length of the breakpoint. For example, if BXDR0 is set to 00000006h, and BXDR7 indicates it has a length of 2 bytes, then an access to 00000006h or 00000007h triggers the breakpoint. BXDR0 and BXDR1 can be paired to specify a range breakpoint if the LEN0 or LEN1 field of BXDR7 is set accordingly. BXDR2 and BXDR3 can be paired to specify a range breakpoint if the LEN2 or LEN3 field of BXDR7 is set accordingly.

**BXDR6\_BXDR7\_MSR Register Map**

63	62	61	60	59	58	57	56	55	54	53	52	51	50	49	48	47	46	45	44	43	42	41	40	39	38	37	36	35	34	33	32
TYPE3			TYPE2				TYPE1				TYPE0				LEN3	LEN2	LEN1	LEN0	RSVD				E3	E2	E1	E0					
31	30	29	28	27	26	25	24	23	22	21	20	19	18	17	16	15	14	13	12	11	10	9	8	7	6	5	4	3	2	1	0
RSVD																										T3	T2	T1	T0		

**BXDR6\_BXDR7\_MSR Bit Descriptions**

Bit	Name	Description
<b>BXDR7</b>		
63:60	TYPE3	<b>Extended Breakpoint 3 Type.</b> Selects the type of extended breakpoint 3. 0000: IM memory read (Default) 0001: DM memory read 0010: DM memory write 0011: DM memory read/write 0100: DM I/O read 0101: DM I/O write 0110: DM I/O read/write 0111: GLBus snoop for read 1000: GLBus snoop for write 1001: GLBus snoop for write-invalidate 1010: MSR read 1011: MSR write All Others: Undefined, breakpoint will not trigger
59:56	TYPE2	<b>Extended Breakpoint 2 Type.</b> Selects the type of extended breakpoint 2. See TYPE3 (bits [63:60]) for decode.
55:52	TYPE1	<b>Extended Breakpoint 1 Type.</b> Selects the type of extended breakpoint 1. See TYPE3 (bits [63:60]) for decode.
51:48	TYPE0	<b>Extended Breakpoint 0 Type.</b> Selects the type of extended breakpoint 0. See TYPE3 (bits [63:60]) for decode.
47:46	LEN3	<b>Extended Breakpoint 3 Length.</b> Selects the size of extended breakpoint 3. 00: 1 byte. (Default) 01: 2 bytes. 10: Range from even to odd register. 11: 4 bytes.
45:44	LEN2	<b>Extended Breakpoint 2 Length.</b> Selects the size of extended breakpoint 2. See LEN3 (bits [47:46]) for decode.
43:42	LEN1	<b>Extended Breakpoint 1 Length.</b> Selects the size of extended breakpoint 0. See LEN3 (bits [47:46]) for decode.

**BXDR6\_BXDR7\_MSR Bit Descriptions (Continued)**

Bit	Name	Description
41:40	LEN0	<b>Extended Breakpoint 0 Length.</b> Selects the size of extended breakpoint 1. See LEN3 (bits [47:46]) for decode.
35	E3	<b>Extended Breakpoint 3 Enable.</b> Allows extended breakpoint 3 to be enabled. 0: Disable. 1: Enable.
34	E2	<b>Extended Breakpoint 2 Enable.</b> Allows extended breakpoint 2 to be enabled. 0: Disable. 1: Enable.
33	E1	<b>Extended Breakpoint 1 Enable.</b> Allows extended breakpoint 1 to be enabled. 0: Disable. 1: Enable.
32	E0	<b>Extended Breakpoint 0 Enable.</b> Allows extended breakpoint 0 to be enabled. 0: Disable. 1: Enable.
<b>BXDR6</b>		
31:4	RSVD	<b>Reserved.</b>
3	T3	<b>Extended Breakpoint 3 Triggered.</b> A 1 Indicates that extended breakpoint 3 has triggered. Write to clear. (Default = 0)
2	T2	<b>Extended Breakpoint 2 Triggered.</b> A 1 Indicates that extended breakpoint 2 has triggered. Write to clear. (Default = 0)
1	T1	<b>Extended Breakpoint 1 Triggered.</b> A 1 Indicates that extended breakpoint 1 has triggered. Write to clear. (Default = 0)
0	T0	<b>Extended Breakpoint 0 Triggered.</b> A 1 Indicates that extended breakpoint 0 has triggered. Write to clear. (Default = 0)

**5.5.2.107 Bus Controller Debug Registers 0 through 3 MSRs**

Each of these registers specifies an address that must match the physical address currently in the bus controller in order to trigger the breakpoint. BDR7 is used to enable and specify the type of BDR0-BDR3. If a breakpoint is configured as a memory breakpoint, the address is matched on a QWORD granularity. If a breakpoint is configured as an I/O or MSR breakpoint, the address is matched based on all 32 bits.

**Bus Controller Debug Register 0 MSR (BDR0\_MSR)**

MSR Address 00001970h  
 Type R/W  
 Reset Value 00000000\_00000000h

**Bus Controller Debug Register 2 MSR (BDR2\_MSR)**

MSR Address 00001972h  
 Type R/W  
 Reset Value 00000000\_00000000h

**Bus Controller Debug Register 1 MSR (BDR1\_MSR)**

MSR Address 00001971h  
 Type R/W  
 Reset Value 00000000\_00000000h

**Bus Controller Debug Register 3 MSR (BDR3\_MSR)**

MSR Address 00001973h  
 Type R/W  
 Reset Value 00000000\_00000000h

**BDRx\_MSR Register Map**

63	62	61	60	59	58	57	56	55	54	53	52	51	50	49	48	47	46	45	44	43	42	41	40	39	38	37	36	35	34	33	32
RSVD																															
31	30	29	28	27	26	25	24	23	22	21	20	19	18	17	16	15	14	13	12	11	10	9	8	7	6	5	4	3	2	1	0
PHYS_ADDR																															

**BDRx\_MSR Bit Descriptions**

Bit	Name	Description
63:32	RSVD	<b>Reserved.</b> (Default = 0)
31:0	PHYS_ADDR	<b>Address Match Value for BDRx.</b> (Default = 0)

**5.5.2.108 Bus Controller Debug Register 6 MSR (BDR6\_MSR)**

MSR Address 00001976h  
 Type R/W  
 Reset Value 00000000\_00000000h

This register contains the status of the bus controller breakpoints. When a breakpoint occurs, the corresponding status bit is set in this register. The status bits remain set until cleared by an MSR write.

**BDR6\_MSR Register Map**

63	62	61	60	59	58	57	56	55	54	53	52	51	50	49	48	47	46	45	44	43	42	41	40	39	38	37	36	35	34	33	32
RSVD																															
31	30	29	28	27	26	25	24	23	22	21	20	19	18	17	16	15	14	13	12	11	10	9	8	7	6	5	4	3	2	1	0
RSVD																												T3	T2	T1	T0

**BDR6\_MSR Bit Descriptions**

Bit	Name	Description
63:4	RSVD	<b>Reserved.</b> (Default = 0)
3	T3	<b>Breakpoint 3 Triggered.</b> A 1 Indicates that breakpoint 3 has triggered. Write to clear. (Default = 0)
2	T2	<b>Breakpoint 2 Triggered.</b> A 1 Indicates that breakpoint 2 has triggered. Write to clear. (Default = 0)
1	T1	<b>Breakpoint 1 Triggered.</b> A 1 Indicates that breakpoint 1 has triggered. Write to clear. (Default = 0)
0	T0	<b>Breakpoint 0 Triggered.</b> A 1 Indicates that breakpoint 0 has triggered. Write to clear. (Default = 0)

**5.5.2.109 Bus Controller Debug Register 7 MSR (BDR7\_MSR)**

MSR Address 00001977h  
 Type R/W  
 Reset Value 00000000\_00000000h

This register is the bus controller breakpoint control/enable register.

**BDR7\_MSR Register Map**

63	62	61	60	59	58	57	56	55	54	53	52	51	50	49	48	47	46	45	44	43	42	41	40	39	38	37	36	35	34	33	32
RSVD																															
31	30	29	28	27	26	25	24	23	22	21	20	19	18	17	16	15	14	13	12	11	10	9	8	7	6	5	4	3	2	1	0
TYPE3			TYPE2			TYPE1			TYPE0			RSVD																E3	E2	E1	E0

**BDR7\_MSR Bit Descriptions**

Bit	Name	Description
63:32	RSVD	<b>Reserved.</b> (Default = 0)

## BDR7\_MSR Bit Descriptions

Bit	Name	Description
31:28	TYPE3	<b>Breakpoint 3 Type.</b> Selects the type of extended breakpoint 3. 0000: IM memory read (Default). 0001: DM memory read. 0010: DM memory write. 0011: DM memory read/write. 0100: DM I/O read. 0101: DM I/O write. 0110: DM I/O read/write. 0111: GLBus snoop for read. 1000: GLBus snoop for write. 1001: GLBus snoop for write-invalidate. 1010: MSR read. 1011: MSR write. All Others: Undefined, breakpoint will not trigger.
27:24	TYPE2	<b>Breakpoint 2 Type.</b> Selects the type of extended breakpoint 2. See TYPE3 (bits [31:28]) for decode.
23:20	TYPE1	<b>Breakpoint 1 Type.</b> Selects the type of extended breakpoint 1. See TYPE3 (bits [31:28]) for decode.
19:16	TYPE0	<b>Breakpoint 0 Type.</b> Selects the type of extended breakpoint 0. See TYPE3 (bits [31:28]) for decode.
15:4	RSVD	<b>Reserved.</b> (Default = 0)
3	E3	<b>Breakpoint 3 Enable.</b> Allows extended breakpoint 3 to be enabled. 0: Disable. 1: Enable.
2	E2	<b>Breakpoint 2 Enable.</b> Allows extended breakpoint 2 to be enabled. 0: Disable. 1: Enable.
1	E1	<b>Breakpoint 1 Enable.</b> Allows extended breakpoint 1 to be enabled. 0: Disable. 1: Enable.
0	E0	<b>Breakpoint 0 Enable.</b> Allows extended breakpoint 0 to be enabled. 0: Disable. 1: Enable.

### 5.5.2.110 Memory Subsystem Array Control Enable MSR (MSS\_ARRAY\_CTL\_EN\_MSR)

MSR Address 00001980h  
 Type R/W  
 Reset Value 00000000\_00000000h

The MSRs at addresses 00001980h-00001983h provide alternate array delay control values for the MSS arrays. After a reset, the MSS clock modules provide JTAG-accessible control values. These MSRs can be used by software to override these values.

#### MSS\_ARRAY\_CTL\_EN\_MSR Register Map

63	62	61	60	59	58	57	56	55	54	53	52	51	50	49	48	47	46	45	44	43	42	41	40	39	38	37	36	35	34	33	32
RSVD																															
31	30	29	28	27	26	25	24	23	22	21	20	19	18	17	16	15	14	13	12	11	10	9	8	7	6	5	4	3	2	1	0
RSVD																															EN

#### MSS\_ARRAY\_CTL\_EN\_MSR Bit Descriptions

Bit	Name	Description
63:1	RSVD	<b>Reserved.</b> (Default = 0)
0	EN	<b>Enable.</b> Enable the array control values in this register to be used instead of those provided by the clock modules.  0: Disable. 1: Enable.

### 5.5.2.111 Memory Subsystem Array Control 0 MSR (MSS\_ARRAY\_CTL0\_MSR)

MSR Address 00001981h  
 Type R/W  
 Reset Value 00000000\_2010F3C9h

#### MSS\_ARRAY\_CTL0\_MSR Register Map

63	62	61	60	59	58	57	56	55	54	53	52	51	50	49	48	47	46	45	44	43	42	41	40	39	38	37	36	35	34	33	32	
RSVD																															DMDATA1	
31	30	29	28	27	26	25	24	23	22	21	20	19	18	17	16	15	14	13	12	11	10	9	8	7	6	5	4	3	2	1	0	
DMDATA1				DMDATA0								DMTAG1				DMTAG0				L2TLB1		L2TLB0										

#### MSS\_ARRAY\_CTL0\_MSR Bit Descriptions

Bit	Name	Description
63:36	RSVD	<b>Reserved.</b> (Default = 0)
35:27	DMDATA1	<b>Data Memory Subsystem Data 1 Delay Control.</b> (Default = 04)
26:18	DMDATA0	<b>Data Memory Subsystem Data 0 Delay Control.</b> (Default = 04)
17:12	DMTAG1	<b>Data Memory Subsystem Tag 1 Delay Control.</b> (Default = F)
11:6	DMTAG0	<b>Data Memory Subsystem Tag 0 Delay Control.</b> (Default = F)
5:3	L2TB1	<b>Data Memory Subsystem L2 TLB 1 Delay Control.</b> (Default = 1)
2:0	L2TB0	<b>Data Memory Subsystem L2 TLB 0 Delay Control.</b> (Default = 1)



**5.5.2.112 Memory Subsystem Array Control 1 MSR (MSS\_ARRAY\_CTL1\_MSR)**

MSR Address 00001982h  
 Type R/W  
 Reset Value 00000000\_104823CFh

**MSS\_ARRAY\_CTL1\_MSR Register Map**

63	62	61	60	59	58	57	56	55	54	53	52	51	50	49	48	47	46	45	44	43	42	41	40	39	38	37	36	35	34	33	32
RSVD																															
31	30	29	28	27	26	25	24	23	22	21	20	19	18	17	16	15	14	13	12	11	10	9	8	7	6	5	4	3	2	1	0
RSVD		IMDATA1										IMDATA0										IMTAG1					IMTAG0				

**MSS\_ARRAY\_CTL1\_MSR Bit Descriptions**

Bit	Name	Description
63:30	RSVD	Reserved. (Default = 0)
29:21	IMDATA1	Instruction Memory Subsystem Data 1 Delay Control. (Default = 82)
20:12	IMDATA0	Instruction Memory Subsystem Data 0 Delay Control. (Default = 82)
11:6	IMTAG1	Instruction Memory Subsystem Tag 1 Delay Control. (Default = F)
5:0	IMTAG0	Instruction Memory Subsystem Tag 0 Delay Control. (Default = F)

**5.5.2.113 Memory Subsystem Array Control 2 MSR (MSS\_ARRAY\_CTL2\_MSR)**

MSR Address 00001983h  
 Type R/W  
 Reset Value 00000104\_820C30C3h

L2 delay control settings.

**MSS\_ARRAY\_CTL2\_MSR Register Map**

63	62	61	60	59	58	57	56	55	54	53	52	51	50	49	48	47	46	45	44	43	42	41	40	39	38	37	36	35	34	33	32
RSVD																						L2DATA1					L2DATA0				
31	30	29	28	27	26	25	24	23	22	21	20	19	18	17	16	15	14	13	12	11	10	9	8	7	6	5	4	3	2	1	0
L2DATA0								L2TAG3				L2TAG2				L2TAG1				L2TAG0											

**MSS\_ARRAY\_CTL2\_MSR Bit Descriptions**

Bit	Name	Description
63:42	RSVD	Reserved. (Default = 0)
41:33	L2DATA1	L2 Cache Data 1 Delay Setting. (Default = 82)
32:24	L2DATA0	L2 Cache Data 0 Delay Setting. (Default = 82)
23:18	L2TAG3	L2 Cache Tag 3 Delay Setting. (Default = 3)
17:12	L2TAG2	L2 Cache Tag 2 Delay Setting. (Default = 3)
11:6	L2TAG1	L2 Cache Tag 1 Delay Setting. (Default = 3)
5:0	L2TAG0	L2 Cache Tag 0 Delay Setting. (Default = 3)

**5.5.2.114 FPU Modes MSR (FP\_MODE\_MSR)**

MSR Address 00001A00h  
 Type R/W  
 Reset Value 00000000\_00000000h

**FP\_MODE\_MSR Register Map**

63	62	61	60	59	58	57	56	55	54	53	52	51	50	49	48	47	46	45	44	43	42	41	40	39	38	37	36	35	34	33	32
RSVD																															
31	30	29	28	27	26	25	24	23	22	21	20	19	18	17	16	15	14	13	12	11	10	9	8	7	6	5	4	3	2	1	0
RSVD																														FPU_SP	FPU_IPE

**FP\_MODE\_MSR Bit Descriptions**

Bit	Name	Description
63:2	RSVD	<b>Reserved.</b> Write as read.
1	FPU_SP	<p><b>Limit Results to Single Precision.</b> The FPU datapath width is single-precision. Operations on single precision numbers can generally be completed in one cycle, but double or extended precision numbers takes many cycles. This bit overrides the precision control bits in the x87 Mode Control register (of the FPU Instruction Set), and causes the FPU to operate as if the precision control is set to single precision (00).</p> <p>0: Disable. 1: Enable limit to single precision.</p>
0	FPU_IPE	<p><b>Enable Force of Imprecise Exceptions.</b> For precise exceptions, the FPU allows only one instruction to be in the pipeline at a time when any FPU exceptions are unmasked. This results in a huge performance penalty. To run the FPU at full speed, it is necessary to mask all exceptions in the FPU_CW_MSR (MSR 00001A10h[11:0]).</p> <p>When this bit is set, the FPU is allowed to run at full speed even if there are unmasked exceptions in the FPU_CW. With this bit set, exceptions will be generated, however, there is no guarantee that the exception will occur on any particular instruction boundary.</p> <p>It is known that setting this bit will cause some diagnostic software to fail. It is recommended to be set only when the FPU exception handler does not need to handle exceptions on the specific instruction boundary.</p> <p>0: Disable. 1: Enable.</p>

**5.5.2.115 FPU Reserved MSR (FPU\_RSVD\_MSR)**

MSR Address 00001A01h  
 Type R/W  
 Reset Value 00000000\_00000000h

This register is reserved for internal testing; do not write.

**5.5.2.116 FPU Reserved MSR (FPU\_RSVD\_MSR)**

MSR Address 00001A03h  
 Type R/W  
 Reset Value 00000000\_00000000h

This register is reserved for internal testing; do not write.

**5.5.2.117 FPU x87 Control Word MSR (FPU\_CW\_MSR)**

MSR Address 00001A10h  
 Type R/W  
 Reset Value 00000000\_00000040h

**FPU\_CW\_MSR Register Map**

63	62	61	60	59	58	57	56	55	54	53	52	51	50	49	48	47	46	45	44	43	42	41	40	39	38	37	36	35	34	33	32
RSVD																															
31	30	29	28	27	26	25	24	23	22	21	20	19	18	17	16	15	14	13	12	11	10	9	8	7	6	5	4	3	2	1	0
RSVD																FPU_CW															

**FPU\_CW\_MSR Bit Descriptions**

Bit	Name	Description
63:12	RSVD	<b>Reserved.</b> Write as read.
11:0	FPU_CW	<b>FPU Control Word.</b>

**5.5.2.118 FPU x87 Status Word MSR (FPU\_SW\_MSR)**

MSR Address 00001A11h  
 Type R/W  
 Reset Value 00000000\_00000000h

**FPU\_SW\_MSR Register Map**

63	62	61	60	59	58	57	56	55	54	53	52	51	50	49	48	47	46	45	44	43	42	41	40	39	38	37	36	35	34	33	32
RSVD																															
31	30	29	28	27	26	25	24	23	22	21	20	19	18	17	16	15	14	13	12	11	10	9	8	7	6	5	4	3	2	1	0
RSVD																FPU_SW															

**FPU\_SW\_MSR Bit Descriptions**

Bit	Name	Description
63:16	RSVD	<b>Reserved.</b> Write as read.
15:0	FPU_SW	<b>FPU Status Word.</b>

**5.5.2.119 FPU x87 Tag Word MSR (FPU\_TW\_MSR)**

MSR Address 00001A12h  
 Type R/W  
 Reset Value 00000000\_00000000h

**FPU\_TW\_MSR Register Map**

63	62	61	60	59	58	57	56	55	54	53	52	51	50	49	48	47	46	45	44	43	42	41	40	39	38	37	36	35	34	33	32
RSVD																															
31	30	29	28	27	26	25	24	23	22	21	20	19	18	17	16	15	14	13	12	11	10	9	8	7	6	5	4	3	2	1	0
RSVD																FPU_TW															

## FPU\_TW\_MSR Bit Descriptions

Bit	Name	Description
63:16	RSVD	<b>Reserved.</b> Write as read.
15:0	FPU_TW	<b>FPU Tag Word.</b>

## 5.5.2.120 FPU Busy MSR (FPU\_BUSY\_MSR)

MSR Address 00001A13h  
 Type RO  
 Reset Value 00000000\_00000000h

## FPU\_BUSY\_MSR Register Map

63	62	61	60	59	58	57	56	55	54	53	52	51	50	49	48	47	46	45	44	43	42	41	40	39	38	37	36	35	34	33	32
RSVD																															
31	30	29	28	27	26	25	24	23	22	21	20	19	18	17	16	15	14	13	12	11	10	9	8	7	6	5	4	3	2	1	0
RSVD																															FPU_BUSY

## FPU\_BUSY\_MSR Bit Descriptions

Bit	Name	Description
63:1	RSVD	<b>Reserved.</b> Reads back as 0.
0	FPU_BUSY	<b>FPU Busy.</b> Software must check that the FPU is Idle before accessing MSRs 00001A10h-00001A12h and 00001A40h-00001A6Fh. 0: FPU Idle. 1: FPU Busy.

## 5.5.2.121 FPU Register Map MSR (FPU\_MAP\_MSR)

MSR Address 00001A14h  
 Type RO  
 Reset Value 00000000\_76543210h

## FPU\_MAP\_MSR Register Map

63	62	61	60	59	58	57	56	55	54	53	52	51	50	49	48	47	46	45	44	43	42	41	40	39	38	37	36	35	34	33	32
RSVD																															
31	30	29	28	27	26	25	24	23	22	21	20	19	18	17	16	15	14	13	12	11	10	9	8	7	6	5	4	3	2	1	0
FPU_REG_MAP																															

## FPU\_MAP\_MSR Bit Descriptions

Bit	Name	Description
63:32	RSVD	<b>Reserved.</b>
31:0	FPU_REG_MAP	<b>FPU Register Map.</b> Internal mapping of architectural registers to physical registers in the register array.

**5.5.2.122 Mantissa of Rx MSRs**

**Mantissa of R0 MSR (FPU\_MR0\_MSR)**

MSR Address 00001A40h  
 Type R/W  
 Reset Value xxxxxxxx\_xxxxxxxh

**Mantissa of R8 MSR (FPU\_MR8\_MSR)**

MSR Address 00001A50h  
 Type R/W  
 Reset Value xxxxxxxx\_xxxxxxxh

**Mantissa of R1 MSR (FPU\_MR1\_MSR)**

MSR Address 00001A42h  
 Type R/W  
 Reset Value xxxxxxxx\_xxxxxxxh

**Mantissa of R9 MSR (FPU\_MR9\_MSR)**

MSR Address 00001A52h  
 Type R/W  
 Reset Value xxxxxxxx\_xxxxxxxh

**Mantissa of R2 MSR (FPU\_MR2\_MSR)**

MSR Address 00001A44h  
 Type R/W  
 Reset Value xxxxxxxx\_xxxxxxxh

**Mantissa of R10 MSR (FPU\_MR10\_MSR)**

MSR Address 00001A54h  
 Type R/W  
 Reset Value xxxxxxxx\_xxxxxxxh

**Mantissa of R3 MSR (FPU\_MR3\_MSR)**

MSR Address 00001A46h  
 Type R/W  
 Reset Value xxxxxxxx\_xxxxxxxh

**Mantissa of R11 MSR (FPU\_MR11\_MSR)**

MSR Address 00001A56h  
 Type R/W  
 Reset Value xxxxxxxx\_xxxxxxxh

**Mantissa of R4 MSR (FPU\_MR4\_MSR)**

MSR Address 00001A48h  
 Type R/W  
 Reset Value xxxxxxxx\_xxxxxxxh

**Mantissa of R12 MSR (FPU\_MR12\_MSR)**

MSR Address 00001A58h  
 Type R/W  
 Reset Value xxxxxxxx\_xxxxxxxh

**Mantissa of R5 MSR (FPU\_MR5\_MSR)**

MSR Address 00001A4Ah  
 Type R/W  
 Reset Value xxxxxxxx\_xxxxxxxh

**Mantissa of R13 MSR (FPU\_MR13\_MSR)**

MSR Address 00001A5Ah  
 Type R/W  
 Reset Value xxxxxxxx\_xxxxxxxh

**Mantissa of R6 MSR (FPU\_MR6\_MSR)**

MSR Address 00001A4Ch  
 Type R/W  
 Reset Value xxxxxxxx\_xxxxxxxh

**Mantissa of R14 MSR (FPU\_MR14\_MSR)**

MSR Address 00001A5Ch  
 Type R/W  
 Reset Value xxxxxxxx\_xxxxxxxh

**Mantissa of R7 MSR (FPU\_MR7\_MSR)**

MSR Address 00001A4Eh  
 Type R/W  
 Reset Value xxxxxxxx\_xxxxxxxh

**Mantissa of R15 MSR (FPU\_MR15\_MSR)**

MSR Address 00001A5Eh  
 Type R/W  
 Reset Value xxxxxxxx\_xxxxxxxh

**FPU\_MR<sub>x</sub>\_MSR Register Map**

63	62	61	60	59	58	57	56	55	54	53	52	51	50	49	48	47	46	45	44	43	42	41	40	39	38	37	36	35	34	33	32
FPU_MR <sub>x</sub>																															
31	30	29	28	27	26	25	24	23	22	21	20	19	18	17	16	15	14	13	12	11	10	9	8	7	6	5	4	3	2	1	0
FPU_MR <sub>x</sub>																															

**FPU\_MR<sub>x</sub>\_MSR Bit Descriptions**

Bit	Name	Description
63:0	FPU_MR <sub>x</sub>	Mantissa of FPU Rx MSR.

5.5.2.123 Exponent of Rx MSRs

**Exponent of R0 MSR (FPU\_ER0\_MSR)**

MSR Address 00001A41h  
 Type R/W  
 Reset Value 00000000\_0000xxxxh

**Exponent of R8 MSR (FPU\_ER8\_MSR)**

MSR Address 00001A51h  
 Type R/W  
 Reset Value 00000000\_0000xxxxh

**Exponent of R1 MSR (FPU\_ER1\_MSR)**

MSR Address 00001A43h  
 Type R/W  
 Reset Value 00000000\_0000xxxxh

**Exponent of R9 MSR (FPU\_ER9\_MSR)**

MSR Address 00001A53h  
 Type R/W  
 Reset Value 00000000\_0000xxxxh

**Exponent of R2 MSR (FPU\_ER2\_MSR)**

MSR Address 00001A45h  
 Type R/W  
 Reset Value 00000000\_0000xxxxh

**Exponent of R10 MSR (FPU\_ER10\_MSR)**

MSR Address 00001A55h  
 Type R/W  
 Reset Value 00000000\_0000xxxxh

**Exponent of R3 MSR (FPU\_ER3\_MSR)**

MSR Address 00001A47h  
 Type R/W  
 Reset Value 00000000\_0000xxxxh

**Exponent of R11 MSR (FPU\_ER11\_MSR)**

MSR Address 00001A57h  
 Type R/W  
 Reset Value 00000000\_0000xxxxh

**Exponent of R4 MSR (FPU\_ER4\_MSR)**

MSR Address 00001A49h  
 Type R/W  
 Reset Value 00000000\_0000xxxxh

**Exponent of R12 MSR (FPU\_ER12\_MSR)**

MSR Address 00001A59h  
 Type R/W  
 Reset Value 00000000\_0000xxxxh

**Exponent of R5 MSR (FPU\_ER5\_MSR)**

MSR Address 00001A4Bh  
 Type R/W  
 Reset Value 00000000\_0000xxxxh

**Exponent of R13 MSR (FPU\_ER13\_MSR)**

MSR Address 00001A5Bh  
 Type R/W  
 Reset Value 00000000\_0000xxxxh

**Exponent of R6 MSR (FPU\_ER6\_MSR)**

MSR Address 00001A4Dh  
 Type R/W  
 Reset Value 00000000\_0000xxxxh

**Exponent of R14 MSR (FPU\_ER14\_MSR)**

MSR Address 00001A5Dh  
 Type R/W  
 Reset Value 00000000\_0000xxxxh

**Exponent of R7 MSR (FPU\_ER7\_MSR)**

MSR Address 00001A4Fh  
 Type R/W  
 Reset Value 00000000\_0000xxxxh

**Exponent of R15 MSR (FPU\_ER15\_MSR)**

MSR Address 00001A5Fh  
 Type R/W  
 Reset Value 00000000\_0000xxxxh

**FPU\_ERx\_MSR Register Map**

63	62	61	60	59	58	57	56	55	54	53	52	51	50	49	48	47	46	45	44	43	42	41	40	39	38	37	36	35	34	33	32
RSVD																															
31	30	29	28	27	26	25	24	23	22	21	20	19	18	17	16	15	14	13	12	11	10	9	8	7	6	5	4	3	2	1	0
FPU_ERx																															

**FPU\_ERx\_MSR Bit Descriptions**

Bit	Name	Description
63:16	RSVD	<b>Reserved.</b> Write as read.
15:0	FPU_ERx	<b>Exponent of FPU Rx MSR.</b>

**5.5.2.124 FPU Reserved MSRs (FPU\_RSVD\_MSR)**

MSR addresses 00001A60h through 00001A6F are reserved for internal storage purposes and should not be written to.

**5.5.2.125 CPU ID MSRs****Standard Levels and Vendor ID String 1 (CPUID0\_MSR)**

MSR Address 00003000h  
Type R/W  
Reset Value 68747541\_00000001h

**Vendor ID Strings 2 and 3 (CPUID1\_MSR)**

MSR Address 00003001h  
Type R/W  
Reset Value 69746E65\_444D4163h

**Type/Family/Model/Step (CPUID2\_MSR)**

MSR Address 00003002h  
Type R/W  
Reset Value 00000400\_000005A2h

**Feature Flags (CPUID3\_MSR)**

MSR Address 00003003h  
Type R/W  
Reset Value 0088A93D\_00000000h

**Reserved (CPUID4\_MSR)**

MSR Address 00003004h  
Type WO  
Reset Value 00000000\_00000000h

**Reserved (CPUID5\_MSR)**

MSR Address 00003005h  
Type WO  
Reset Value 00000000\_00000000h

**Max Extended Levels 1 (CPUID6\_MSR)**

MSR Address 00003006h  
Type R/W  
Reset Value 68747541\_80000006h

**Max Extended Levels 2 (CPUID7\_MSR)**

MSR Address 00003007h  
Type R/W  
Reset Value 69746E65\_444D4163h

**Extended Type/Family/Model/Stepping (CPUID8\_MSR)**

MSR Address 00003008h  
Type R/W  
Reset Value 00000000\_000005A1h

**Extended Feature Flags (CPUID9\_MSR)**

MSR Address 00003009h  
Type R/W  
Reset Value C0C0A13D\_00000000h

**CPU Marketing Name 1 (CPUIDA\_MSR)**

MSR Address 0000300Ah  
Type R/W  
Reset Value 4D542865\_646F6547h

**CPU Marketing Name 2 (CPUIDB\_MSR)**

MSR Address 0000300Bh  
Type R/W  
Reset Value 72676574\_6E492029h

**CPU Marketing Name 3 (CPUIDC\_MSR)**

MSR Address 0000300Ch  
Type R/W  
Reset Value 6F725020\_64657461h

**CPU Marketing Name 4 (CPUIDD\_MSR)**

MSR Address 0000300Dh  
Type R/W  
Reset Value 6220726F\_73736563h

**CPU Marketing Name 5 (CPUIDE\_MSR)**

MSR Address 0000300Eh  
Type R/W  
Reset Value 43502044\_4D412079h

**CPU Marketing Name 6 (CPUIDF\_MSR)**

MSR Address 0000300Fh  
Type R/W  
Reset Value 00000000\_00000053h

**L1 TLB Information (CPUID10\_MSR)**

MSR Address 00003010h  
Type R/W  
Reset Value FF10FF10\_00000000h

**L1 Cache Information (CPUID11\_MSR)**

MSR Address 00003011h  
Type R/W  
Reset Value 40100120\_40100120h

**L2 TLB Information (CPUID12\_MSR)**

MSR Address 00003012h  
Type R/W  
Reset Value 00002040\_0000F004h

**L2 Cache Information (CPUID13\_MSR)**

MSR Address 00003013h  
Type R/W  
Reset Value 00000000\_00804120h

### CPUI Dx\_MSR Register Map

63	62	61	60	59	58	57	56	55	54	53	52	51	50	49	48	47	46	45	44	43	42	41	40	39	38	37	36	35	34	33	32
CPUI Dx																															
31	30	29	28	27	26	25	24	23	22	21	20	19	18	17	16	15	14	13	12	11	10	9	8	7	6	5	4	3	2	1	0
CPUI Dx																															

### CPUI Dx\_MSR Bit Descriptions

Bit	Name	Description
63:0	CPUI D0	<b>Standard Levels and Vendor ID String 1.</b> Same data as CPUID instruction [00000000] EBX/EAX.
63:0	CPUI D1	<b>Vendor ID Strings 2 and 3.</b> Same data as CPUID instruction [00000000] EDX/ECX.
63:0	CPUI D2	<b>Type/Family/Model/Step.</b> Same data as CPUID instruction [00000001] EBX/EAX.
63:0	CPUI D3	<b>Feature Flags.</b> Same data as CPUID instruction [00000001] EDX/ECX.
63:0	CPUI D4	<b>Reserved.</b> This register is not used in the CPU Core module.
63:0	CPUI D5	<b>Reserved.</b> This register is not used in the CPU Core module.
63:0	CPUI D6	<b>CPUI D Max Extended Levels.</b> Same data as CPUID instruction [80000000] EBX/EAX.
63:0	CPUI D7	<b>CPUI D Max Extended Levels.</b> Same data as CPUID instruction [80000000] EDX/ECX.
63:0	CPUI D8	<b>Extended Type/Family/Model/Stepping.</b> Same data as CPUID instruction [80000001] EBX/EAX.
63:0	CPUI D9	<b>Extended Feature Flags.</b> Same data as CPUID instruction [80000001] EDX/ECX.
63:0	CPUI DA	<b>CPU Marketing Name 1.</b> Same data as CPUID instruction [80000002] EBX/EAX.
63:0	CPUI DB	<b>CPU Marketing Name 2.</b> Same data as CPUID instruction [80000002] EDX/ECX.
63:0	CPUI DC	<b>CPU Marketing Name 3.</b> Same data as CPUID instruction [80000003] EBX/EAX.
63:0	CPUI DD	<b>CPU Marketing Name 4.</b> Same data as CPUID instruction [80000003] EDX/ECX.
63:0	CPUI DE	<b>CPU Marketing Name 5.</b> Same data as CPUID instruction [80000004] EBX/EAX.
63:0	CPUI DF	<b>CPU Marketing Name 6.</b> Same data as CPUID instruction [80000004] EDX/ECX.
63:0	CPUI D10	<b>L1 TLB Information.</b> Same data as CPUID instruction [80000005] EBX/EAX.
63:0	CPUI D11	<b>L1 Cache Information.</b> Same data as CPUID instruction [80000005] EDX/ECX.
63:0	CPUI D12	<b>L2 TLB Information.</b> Same data as CPUID instruction [80000006] EBX/EAX.
63:0	CPUI D13	<b>L2 Cache Information.</b> Same data as CPUID instruction [80000006] EDX/ECX.



# Integrated Functions 6

The integrated functions of the AMD Geode™ LX processor are:

- GeodeLink™ Memory Controller (GLMC)
- Graphics Processor (GP)
- Display Controller (DC)
- Video Processor (VP)
- GeodeLink Control Processor (GLCP)
- GeodeLink PCI Bridge (GLPCI)
- Video Input Port (VIP)
- Security Block (SB)

This section provides a functional description of each module and its respective registers.

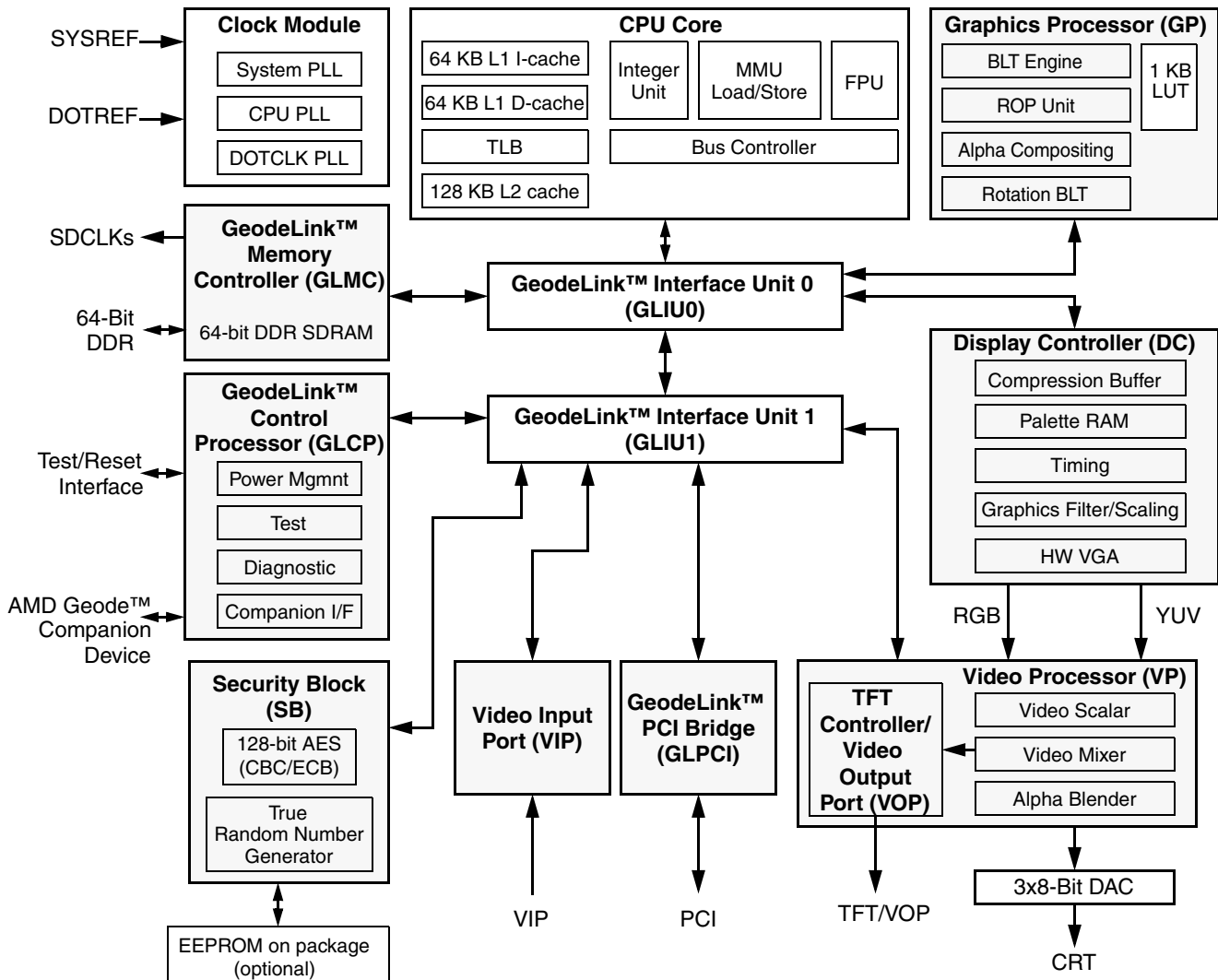


Figure 6-1. Integrated Functions Block Diagram

### 6.1 GeodeLink™ Memory Controller

The GeodeLink™ Memory Controller (GLMC) module supports the Unified Memory Architecture (UMA) of the AMD Geode™ LX processor and controls a 64-bit DDR SDRAM interface without any external buffering. The internal block diagram of the GLMC is shown in Figure 6-2.

The SDRAM memory array contains both the main system memory and the graphics frame buffer. Up to four module banks of SDRAM are supported. Each module bank can have two or four component banks depending on the memory size and organization. The maximum configuration is

four module banks with four component banks, each providing a total of 16 open banks with the maximum memory size supported being 2 GB.

The GLMC handles multiple requests for memory data from the CPU Core, the Graphics Processor, the Display Controller, and the external PCI bus via the GeodeLink Interface Units (GLIUs). The GLMC contains extensive buffering logic that helps minimize contention for memory bandwidth between the various requests.

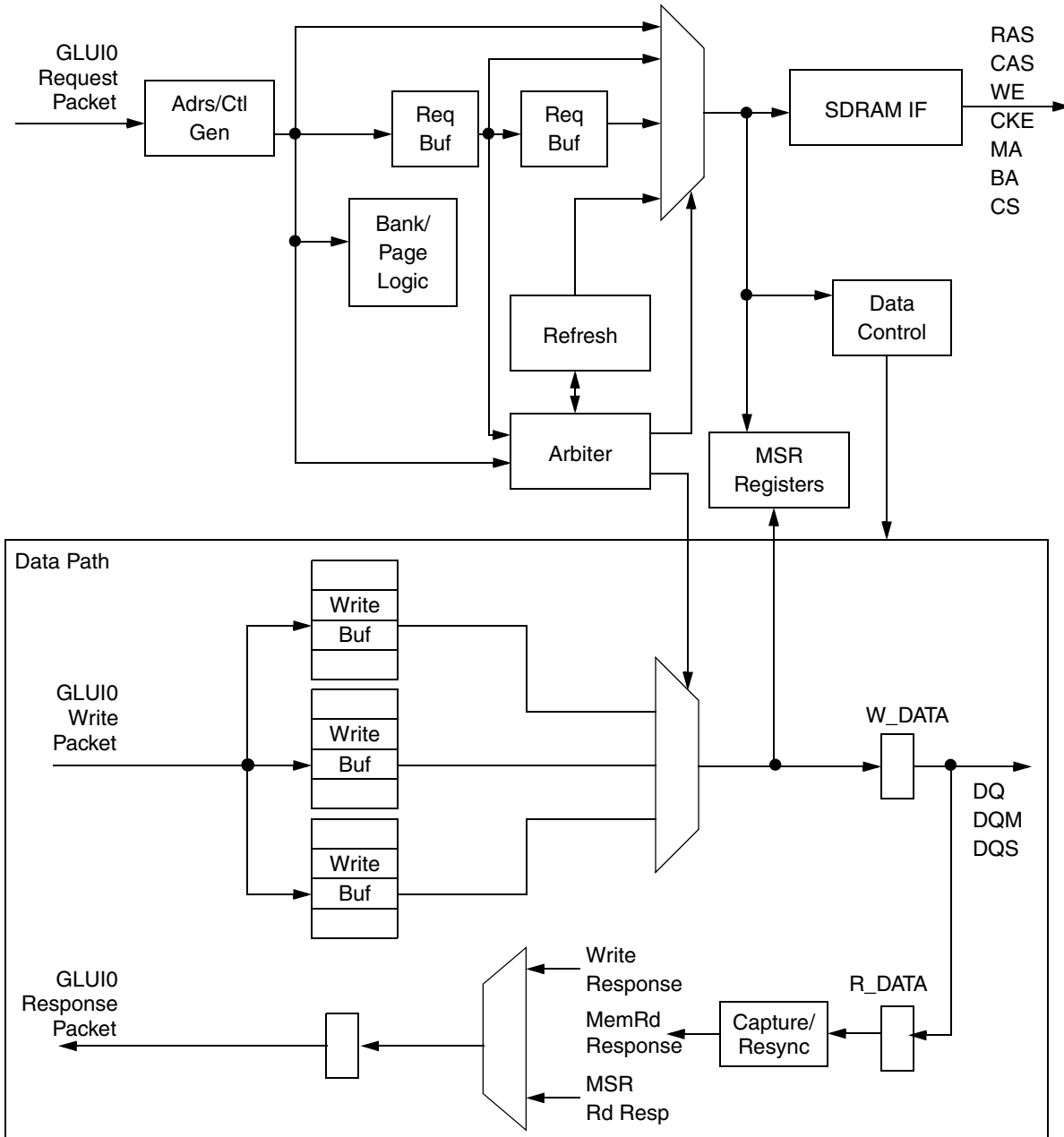


Figure 6-2. GLMC Block Diagram

**Features**

- Supports up to 400 MT/S (million transfers per second) DDR SDRAMs
- Supports 64-bit data interface
- Supports unbuffered DIMMs and SODIMMs
- Can maintain up to 16 open banks at a time
- Can support up to three outstanding requests at a time
- Arbiter reorders requests from different sources to optimize data bus utilization
- Single and burst data phase optimization
- Programmable modes of high and low order address interleaving
- Queues up to eight refreshes
- Supports low power mode
- Highly configurable to obtain best performance for installed DRAM

**6.1.1 Functional Hardware**

**6.1.1.1 Address Translation**

The GLMC module supports two address translations depending on the method used to interleave pages. The hardware supports High Order Interleaving (HOI) or Low Order Interleaving (LOI). Select the interleaving mode used by programming the HOI\_LOI bit of the MC\_CF8F\_DATA register (MSR 20000019h[33]). See Section 6.2.2.10 "Timing and Mode Program (MC\_CF8F\_DATA)" on page 229 for bit description.

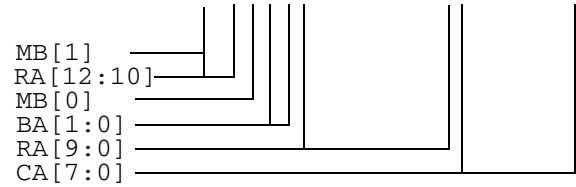
**High Order Interleaving**

High Order Interleaving (HOI) uses the most significant address bits to select which bank the page is located in. Figure 6-3 shows an example of how the Geode LX processor's internal physical addresses are connected to the memory interface address lines.

This interleaving scheme works with any mixture of DIMM types. However, it spreads the pages over wide address ranges. For example, assume a 64 MB memory subsystem with two 32 MB DIMMs installed. Each DIMM has a single module bank, and each module bank contains four component banks. This gives a total of eight component banks in this memory configuration. Each page in a component bank is separated from the next component bank page by 8 MB. See Figure 6-4.

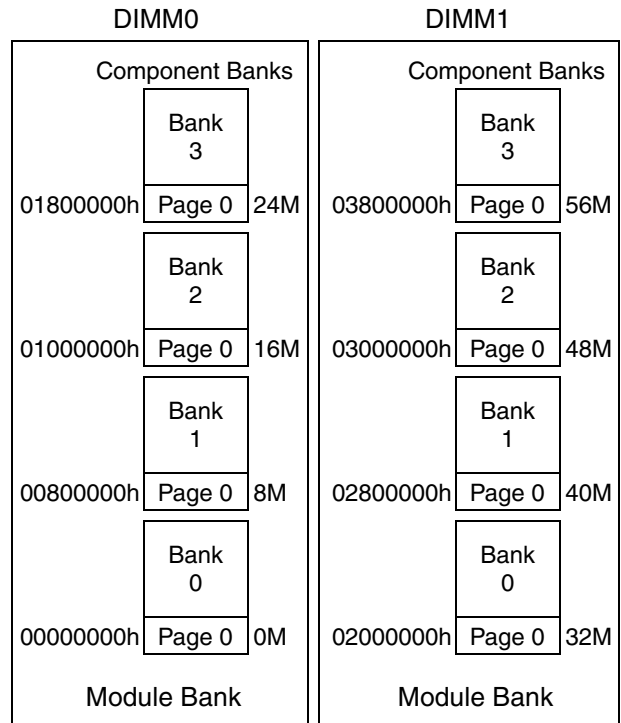
```

Internal  aaaaaaaaaaaaaaaaaaaaaaaaaaaaaa
Physical  222222222111111111110000000
Address   87654321098765432109876543
    
```



RA are the RAS addresses on MA[12:0]  
 CA are the CAS addresses on MA[7:0]

**Figure 6-3. HOI Addressing Example**



**Figure 6-4. HOI Example**

**Auto Low Order Interleaving**

The GLMC requires that module banks [0:1], if both installed, be identical and module banks [2:3], if both installed, be identical. Standard DIMMs and SODIMMs are configured this way. Because of this requirement, when module banks [0:1] are installed or module banks [2:3] are installed, LOI is in effect, when enabled for those bank pairs. If all four module banks [0:3] are identical, then LOI is in effect across all four module banks.

LOI uses the least significant bits after the page bits to select which bank the page is located in. An example is shown in Figure 6-5.

As stated previously, for LOI to be most effective, module banks [0:1] and module banks [2:3] must be of identical configuration. LOI is least effective when only two module banks are installed and of different configuration. This can only happen when one of the module banks is installed in module bank [0 or 1] and the second module bank is installed in module bank [2 or 3]. LOI has the advantage of creating an effective larger moving page throughout memory. Using an example of four identical module banks, with four component banks, and a 1 KB address (8 KB data) page, there would be an effective moving page of 64 KB of data (see Figure 6-6).

**Physical Address to DRAM Address Conversion**

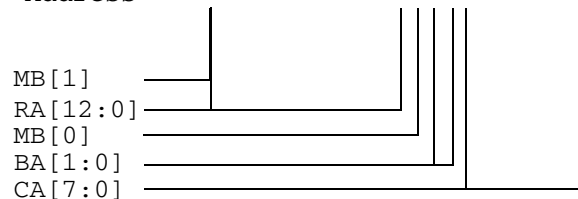
Tables 6-1 and 6-2 on page 213 show Auto LOI address conversion examples when two DIMMs of the same size are used in a system. Table 6-1 shows a one DIMM bank conversion example, while Table 6-2 shows a two DIMM bank example.

Tables 6-3 and 6-4 on page 214 show Non-Auto LOI address conversion examples when either one or two DIMMs of different sizes are used in a system. Table 6-3 shows a one DIMM bank address conversion example, while Table 6-4 shows a two DIMM bank example. The addresses are computed on a per DIMM basis.

Since the DRAM interface is 64 bits wide, the lower three bits of the physical address get mapped onto the DQM[7:0] lines. Thus, the address conversion tables (Tables 6-1 through 6-4) show the physical address starting from A3.

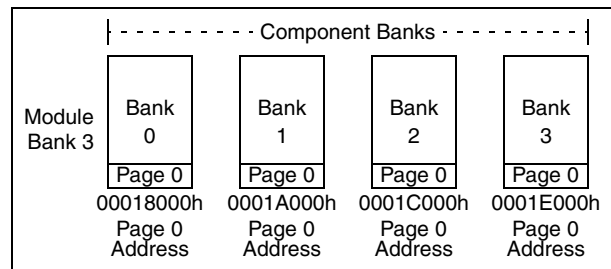
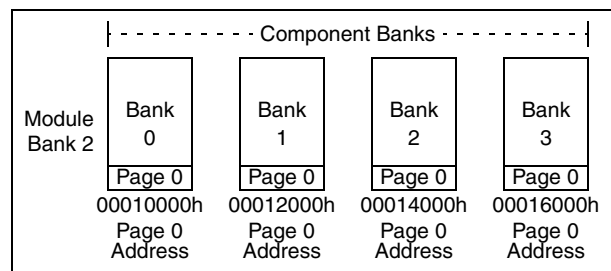
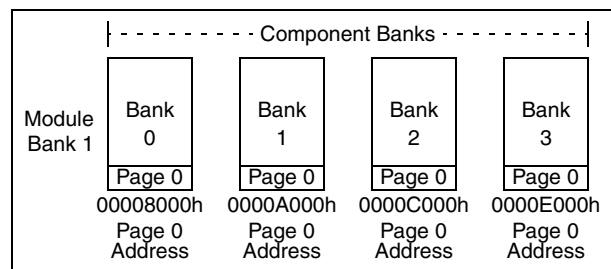
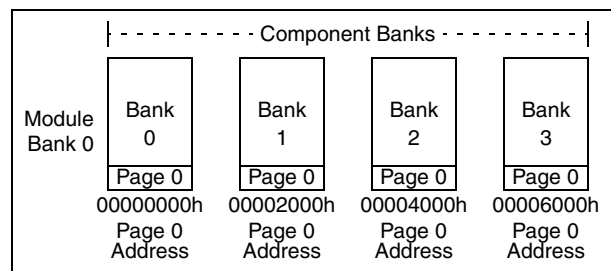
```

Internal  aaaaaaaaaaaaaaaaaaaaaaaaaaaaaa
Physical  222222222111111111110000000
Address   87654321098765432109876543
    
```



RA are the RAS addresses on MA[12:0]  
 CA are the CAS addresses on MA[7:0]

**Figure 6-5. LOI Addressing Example**



**Figure 6-6. LOI Example**

**Table 6-1. LOI - 2 DIMMs, Same Size, 1 DIMM Bank**

Address	1 KB Page Size		2 KB Page Size		4 KB Page Size		Address	1 KB Page Size		2 KB Page Size		4 KB Page Size	
	Row	Col	Row	Col	Row	Col		Row	Col	Row	Col	Row	Col
	2 Component Banks							4 Component Banks					
MA13	A25	--	A26	--	A27	--	A26	--	A27	--	A28	--	
MA12	A24	--	A25	--	A26	--	A25	--	A26	--	A27	--	
MA11	A23	--	A24	--	A25	--	A24	--	A25	--	A26	--	
MA10	A22	--	A23	--	A24	--	A23	--	A24	--	A25	--	
MA9	A21	--	A22	--	A23	---	A22	--	A23	--	A24	--	
MA8	A20	--	A21	--	A22	A11	A21	--	A22	--	A23	A11	
MA7	A19	--	A20	A10	A21	A10	A20	--	A21	A10	A22	A10	
MA6	A18	A9	A19	A9	A20	A9	A19	A9	A20	A9	A21	A9	
MA5	A17	A8	A18	A8	A19	A8	A18	A8	A19	A8	A20	A8	
MA4	A16	A7	A17	A7	A18	A7	A17	A7	A18	A7	A19	A7	
MA3	A15	A6	A16	A6	A17	A6	A16	A6	A17	A6	A18	A6	
MA2	A14	A5	A15	A5	A16	A5	A15	A5	A16	A5	A17	A5	
MA1	A13	A4	A14	A4	A15	A4	A14	A4	A15	A4	A16	A4	
MA0	A12	A3	A13	A3	A14	A3	A13	A3	A14	A3	A15	A3	
CS0#/CS1#	A11		A12		A13		A12		A13		A14		
CS2#/CS3#	--		--		--		--		--		--		
BA0/BA1	A10		A11		A12		A11/A10		A12/A11		A13/A12		

**Table 6-2. LOI - 2 DIMMs, Same Size, 2 DIMM Banks**

Address	1 KB Page Size		2 KB Page Size		4 KB Page Size		Address	1 KB Page Size		2 KB Page Size		4 KB Page Size	
	Row	Col	Row	Col	Row	Col		Row	Col	Row	Col	Row	Col
	2 Component Banks							4 Component Banks					
MA13	A26	--	A27	--	A28	--	A27	--	A28	--	A29	--	
MA12	A25	--	A26	--	A27	--	A26	--	A27	--	A28	--	
MA11	A24	--	A25	--	A26	--	A25	--	A26	--	A27	--	
MA10	A23	--	A24	--	A25	--	A24	--	A25	--	A26	--	
MA9	A22	--	A23	--	A24	--	A23	--	A24	--	A25	--	
MA8	A21	--	A22	--	A23	A11	A22	--	A23	--	A24	A11	
MA7	A20	--	A21	A10	A22	A10	A21	--	A22	A10	A23	A10	
MA6	A19	A9	A20	A9	A21	A9	A20	A9	A21	A9	A22	A9	
MA5	A18	A8	A19	A8	A20	A8	A19	A8	A20	A8	A21	A8	
MA4	A17	A7	A18	A7	A19	A7	A18	A7	A19	A7	A20	A7	
MA3	A16	A6	A17	A6	A18	A6	A17	A6	A18	A6	A19	A6	
MA2	A15	A5	A16	A5	A17	A5	A16	A5	A17	A5	A18	A5	
MA1	A14	A4	A15	A4	A16	A4	A15	A4	A16	A4	A17	A4	
MA0	A13	A3	A14	A3	A15	A3	A14	A3	A15	A3	A16	A3	
CS0#/CS1#	A12		A13		A14		A13		A14		A15		
CS2#/CS3#	A11		A12		A13		A12		A13		A14		
BA0/BA1	A10		A11		A12		A11/A10		A12/A11		A13/A12		

**Table 6-3. Non-Auto LOI - 1 or 2 DIMMs, Different Sizes, 1 DIMM Bank**

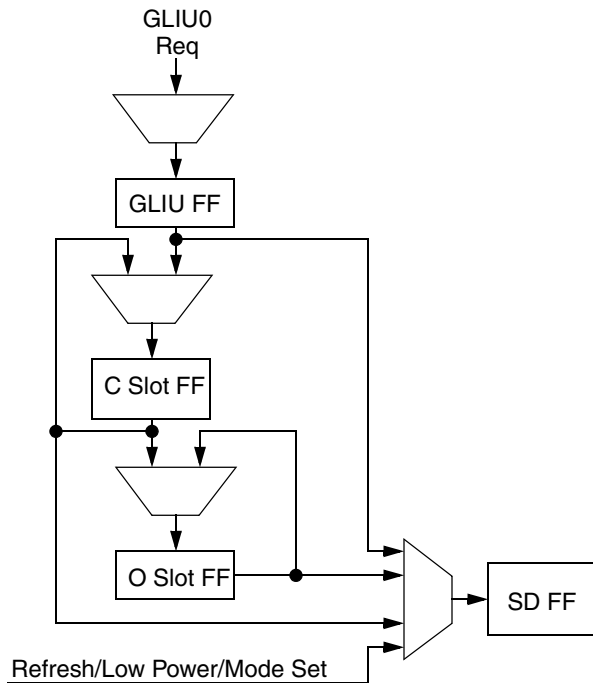
Address	1 KB Page Size		2 KB Page Size		4 KB Page Size		Address	1 KB Page Size		2 KB Page Size		4 KB Page Size	
	Row	Col	Row	Col	Row	Col		Row	Col	Row	Col	Row	Col
	2 Component Banks							4 Component Banks					
MA13	A24	--	A25	--	A26	--	A25	--	A26	--	A27	--	
MA12	A23	--	A24	--	A25	--	A24	--	A25	--	A26	--	
MA11	A22	--	A23	--	A24	--	A23	--	A24	--	A25	--	
MA10	A21	--	A22	--	A23	--	A22	--	A23	--	A24	--	
MA9	A20	--	A21	--	A22	--	A21	--	A22	--	A23	--	
MA8	A19	--	A20	--	A21	A11	A20	--	A21	--	A22	A11	
MA7	A18	--	A19	A10	A20	A10	A19	--	A20	A10	A21	A10	
MA6	A17	A9	A18	A9	A19	A9	A18	A9	A19	A9	A20	A9	
MA5	A16	A8	A17	A8	A18	A8	A17	A8	A18	A8	A19	A8	
MA4	A15	A7	A16	A7	A17	A7	A16	A7	A17	A7	A18	A7	
MA3	A14	A6	A15	A6	A16	A6	A15	A6	A16	A6	A17	A6	
MA2	A13	A5	A14	A5	A15	A5	A14	A5	A15	A5	A16	A5	
MA1	A12	A4	A13	A4	A14	A4	A13	A4	A14	A4	A15	A4	
MA0	A11	A3	A12	A3	A13	A3	A12	A3	A13	A3	A14	A3	
CS0#/CS1#	--		--		--		--		--		--		
CS2#/CS3#	--		--		--		--		--		--		
BA0/BA1	A10		A11		A12		A11/A10		A12/A11		A13/A12		

**Table 6-4. Non-Auto LOI - 1 or 2 DIMMs, Different Sizes, 2 DIMM Banks**

Address	1 KB Page Size		2 KB Page Size		4 KB Page Size		Address	1 KB Page Size		2 KB Page Size		4 KB Page Size	
	Row	Col	Row	Col	Row	Col		Row	Col	Row	Col	Row	Col
	2 Component Banks							4 Component Banks					
MA13	A25	--	A26	--	A27	--	A26	--	A27	--	A28	--	
MA12	A24	--	A25	--	A26	--	A25	--	A26	--	A27	--	
MA11	A23	--	A24	--	A25	--	A24	--	A25	--	A26	--	
MA10	A22	--	A23	--	A24	--	A23	--	A24	--	A25	--	
MA9	A21	--	A22	--	A23	--	A22	--	A23	--	A24	--	
MA8	A20	--	A21	--	A22	A11	A21	--	A22	--	A23	A11	
MA7	A19	--	A20	A10	A21	A10	A20	--	A21	A10	A22	A10	
MA6	A18	A9	A19	A9	A20	A9	A19	A9	A20	A9	A21	A9	
MA5	A17	A8	A18	A8	A19	A8	A18	A8	A19	A8	A20	A8	
MA4	A16	A7	A17	A7	A18	A7	A17	A7	A18	A7	A19	A7	
MA3	A15	A6	A16	A6	A17	A6	A16	A6	A17	A6	A18	A6	
MA2	A14	A5	A15	A5	A16	A5	A15	A5	A16	A5	A17	A5	
MA1	A13	A4	A14	A4	A15	A4	A14	A4	A15	A4	A16	A4	
MA0	A12	A3	A13	A3	A14	A3	A13	A3	A14	A3	A15	A3	
CS0#/CS1#	A11		A12		A13		A12		A13		A14		
CS2#/CS3#	--		--		--		--		--		--		
BA0/BA1	A10		A11		A12		A11/A10		A12/A11		A13/A12		

### 6.1.1.2 Arbitration

The pipelining of the GLMC module requests consists of the GLIU0 interface request plus two request buffers: the C (closed) and O (open) slots (see Figure 6-7). A request is accepted at the GLIU0 interface as long as there is a slot available. The C slot holds a request to a closed page, or a request to an open page that matches a row address. The O slot holds a request to an open page that matches a row address.



**Figure 6-7. Request Pipeline**

Arbitration between the request at the GLIU0 interface, the C request, and the O request at the DRAM end, depend on selection factors that try to optimize DRAM bus utilization and maximize throughput. This may involve reordering transactions as long as ordering rules and coherency are maintained. Requests from the same GeodeLink device source are kept in order. Requests from different sources may pass each other as long as the addresses do not match.

If reordering is allowable, requests may be reordered for the following reasons:

- 1) A request with a higher priority can pass a request in front of it with a lower priority, as long as the higher-priority request is ready to run and nothing else is already running. (Conversely, a request with a lower priority may not pass a request in front of it with greater or equal priority.)
- 2) A younger request that hits to an open page can pass an older request in front of it that is not a page hit.
- 3) A write request still gathering its write data may be passed by a request behind it that is ready to run.
- 4) Writes and reads are clumped together by the GLMC to minimize bus turnarounds.

The criteria for reordering is prioritized as above, with the requests' priority fields (PRI) taking top precedence in determining if reordering may be performed. Reordering based on criterion #2 may only happen if the relative priorities are sorted out as per criterion #1, and so on.

Requests in the C and O slots are run before the request at the GLIU0 interface if the DRAM is ready to receive them. The GLIU0 interface request can pass C and O requests only if the interface request is a read; a write needs to gather data in the write buffer first so it ends up moving to the C and possibly O slot while waiting. (For the case where a GLIU0 non-burst write request and its single beat of write datum are valid in the same clock, writes could possibly be optimized to bypass the write buffer, thus allowing write requests from the GLIU0 interface to be run on the fly at the DRAM interface. Note that only single writes may be optimized; burst writes must be buffered first as there may be bubbles between data beats.)

Requests from the same source whose addresses are within the same cache line are run in order; otherwise, reordering from the same source is allowed.

Typically, refresh requests are run when GLIU0 has indicated that a refresh can be initiated via a NULL refresh request transaction. The GLMC has a refresh counter that, once enabled and initialized with an interval count, freely counts down to keep track of refresh intervals. Each time this refresh counter times out, a refresh request is added to the GLMC refresh queue, which can queue up to eight refresh requests. Once a NULL refresh request is received from GLIU0, and there is at least one refresh request in the refresh queue, and all outstanding transactions are finished in the GLMC, the GLMC deletes one request from the queue and performs one refresh cycle.

If GLIU0 fails to send a NULL request in a timely manner, and eight refreshes queue up without a NULL request from GLIU0, the refresh request is upgraded to the highest priority, and one refresh proceeds. Requests from the GLIU0 interface will not be accepted until the high-priority refresh runs. Mode-register-set requests and low-power-entry are arbitrated at the same level as high priority refresh.

**6.1.1.3 Data Path**

The write datapath utilizes three write buffers to gather write data within a burst, each one is 4 deep x 64 bits. Writes to the buffers are alternated between the three buffers or whichever one is empty. The SID, PID, and implied BEX are also buffered along with the write data. Once the write request has been processed and arbitrated, and the corresponding GLIU0 write data transfer is complete into the buffers, the buffers are then read out and the write command is dispatched out to memory. Which of the three buffers is read out depends on which buffer's SID, PID matches the SID, PID of the write request that won the arbitration for the DRAM. If more than one buffer's SID, PID matches the write request's SID, PID, then the buffer with the older data is read out. The write data is clocked out using a delay-tuned version of the GLMC/SDRAM write clock. Only one transaction's set of write data is written into a buffer; therefore, only three write transactions can be buffered at any time.

The write data is written into and read out of the buffers on the GLIU0 clock, which is twice the frequency of the GLMC/SDRAM clock. The data strobes DQS are also shipped out with each data beat, center-aligned with the data to strobe the data into the DRAM. Unlike SDRAM,

there is a write latency tDQSS between the write command and the first write data presented to DRAM.

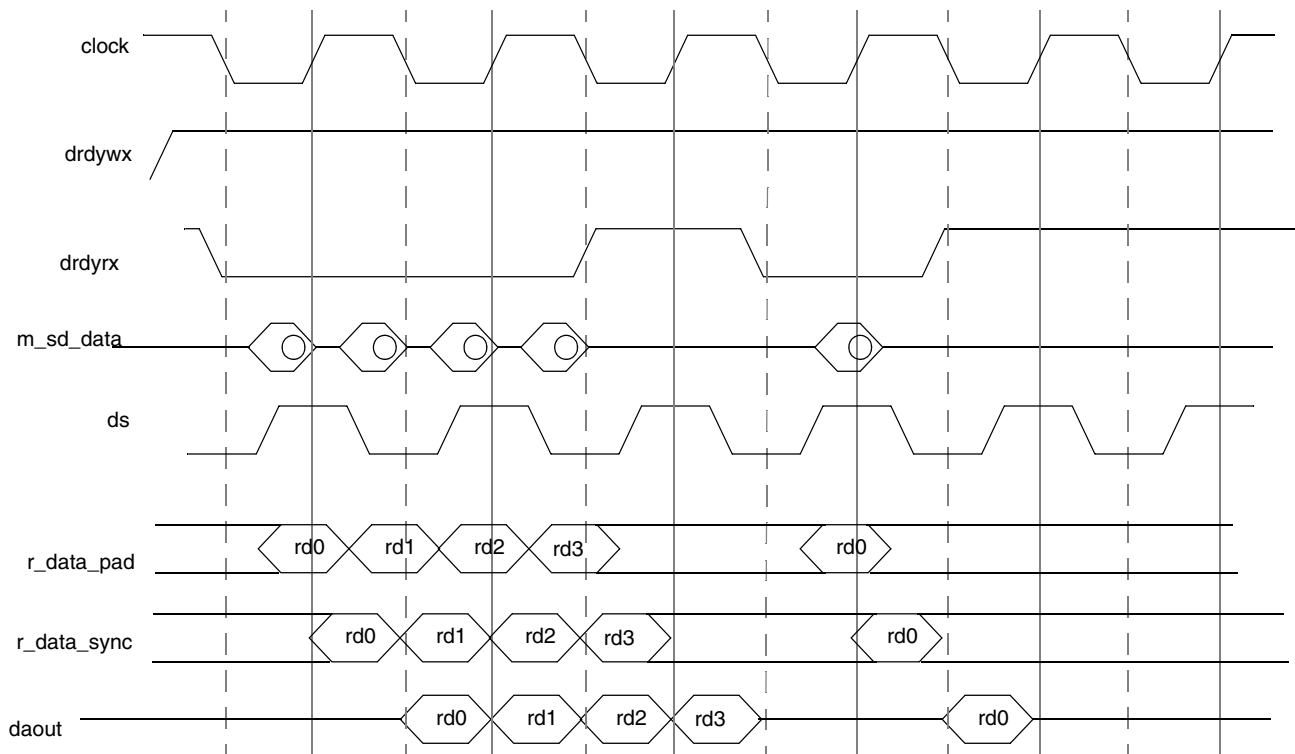
Read data is not buffered to minimize latency. The DQS strobes generated by the DRAM are edge-aligned with the read data, and are used to register the read data. The clock ratio between the GLIU0 clock and GLMC clock is a synchronous 2:1. Since the arrival of the data can vary by as much as one clock from byte to byte, and vary over time and temperature, the GLMC captures and resynchs the data byte by byte as it becomes valid.

**6.1.1.4 GLMC/GLCP/Pad Delay Control Settings**

GLMC signals to and from the pads are controlled with various delay lines in the pads. These delay lines are programmable in the GLCP module. For details on these delay controls, refer to the Section 6.14.2.8 "GLCP I/O Delay Controls (GLCP\_DELAY\_CONTROLS)" on page 549.

**6.1.1.5 Basic Timing Diagrams**

Figure 6-8 and Figure 6-9 on page 217 illustrate timing waveforms for DDR reads and DDR writes.



**Figure 6-8. DDR Reads**



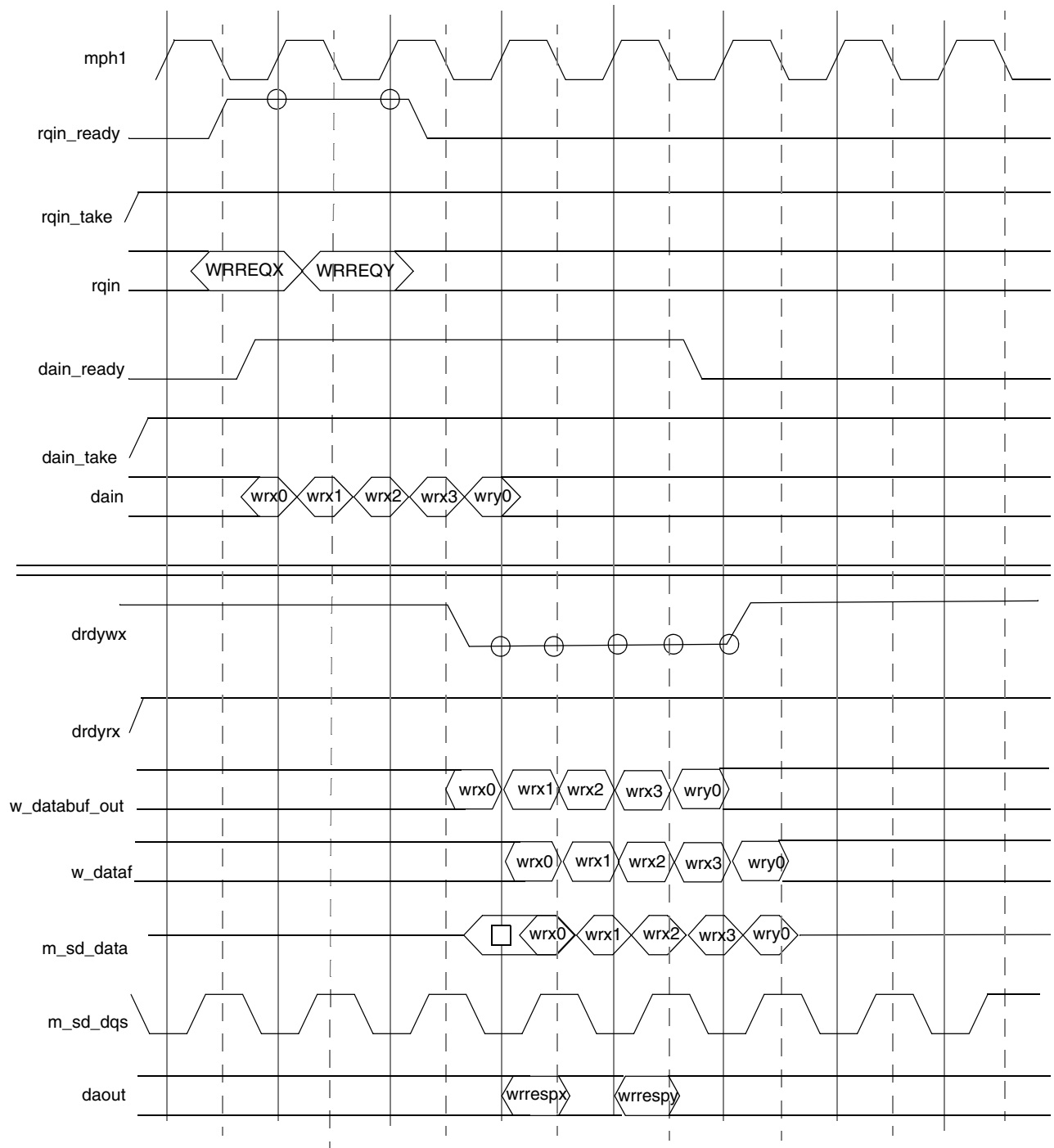


Figure 6-9. DDR Writes

### 6.1.2 Power Control

The GLMC employs some methods of power control for power savings. One method is that it TRI-STATES the GLMC address and control pins when there is no valid address or control data being driven (i.e., when all the chip selects are inactive (high)). This feature is enabled via GLMC MSR 2000001Dh[12] (TRI\_STATE\_DIS), and is disabled by default.

The second and third methods of power control are effected via the GLMC's GLD\_MSR\_PM register (MSR 20002004h). The two modes of power control achievable via this register are PMode0 and PMode1. If PMode0 is enabled, whenever the GLMC's internal state machines are idle and no requests or data are being processed, the GLMC will shut off one of its two clocks, mb\_clk, to save power. Its other clock, mc\_clk, remains active to maintain the refresh counters. If it needs to perform a refresh, or if a GLIU request comes into the GLMC, mb\_clock is reactivated on the next cycle and the GLMC resumes full power. If PMode1 is enabled, the GLMC goes into a deeper level of power-down when it becomes idle. It first sets up the DRAM to go into self-refresh, then shuts off both of its clocks. A wakeup signal in the form of a GLIU request (or reset if the system powers down completely) gets the GLMC back into full power. Per DRAM requirements, the GLMC waits 200 mc\_clocks before accepting the next GLIU request (see GLMC MSR 2000001Ah[15:8]). Also, in order to avoid going into PMode0 or PMode1 unnecessarily, there are programmable sensitivity counters for both modes (see GLMC MSR 20000020h) that provide a way to filter out idle periods less than the duration specified in these counters.

Sequence of steps that occur on entry into PMode1 (i.e., Save-to-RAM):

#### 6.1.2.1 Entry into PMode1 (Save-to-RAM)

When Save-to-RAM is requested:

- 1) ACPI software performs all required memory writes.
- 2) If necessary, write a non-zero value to PM1\_SENS counter (MSR 20000020h[63:32]). This filters out GLMC idle periods less than counter value, so PMode1/Save-to-RAM is only entered on sufficiently long idle periods.
- 3) Set PMode1 in MSR 20002004h[2] to 1 to enable PMode1. On the next GLMC idle condition that is longer than the value in PM1\_SENS, the GLMC performs the following:
- 4) Finish any outstanding memory transactions if any.
- 5) Issue self-refresh command to put DIMMs in self-refresh. This entails issuing a refresh command with CKE = 0.
- 6) Turn off both GLMC's internal mc\_clk and mb\_clk.

#### 6.1.2.2 Resume from PMode1

Either a reset or a GLIU request wakes up the GLMC from PMode1, triggering the following sequence:

- 1) Both internal clocks, mb\_clk and mc\_clk, resume on next clock after wakeup event.
- 2) CKE is released on next clock after clocks resume. If power was removed during entry into PMode1, CKE is released as in a cold boot sequence.
- 3) A Mode Register Set cycle to the DRAM is generated using the data that was programmed into the MC\_CF07\_DATA register (MSR 20000018h)
- 4) After 200 SDCLKs (as set in PM1\_UP\_DLY (MSR 2000001Ah[15:8])), the GLMC starts accepting memory reads/writes.

### 6.1.3 BIOS Initialization Sequence

This is the recommended sequence that BIOS should take to initialize the GLMC and DRAMs properly:

- 1) Initialize the following GLMC registers/bits based on Serial Presence Detect (SPD) values:
  - MSR 20000018h except REF\_INT bits [23:8]
  - MSR 20000019h
- 2) Initialize the following GLMC registers:
  - MSR 2000001Ah[15:8] = C8h
  - MSR 20002004h[2] = 0, [0] = 1
- 3) Release MASK\_CKE[1:0] (MSR 2000001Dh[9:8] = 11).
- 4) Set/clear REF\_TST bit (MSR 20000018h[3]) 16 times to force 8 refreshes. This also causes a precharge-all before the first refresh, per JEDEC requirement.
- 5) Initialize REF\_INT (MSR 20000018h[23:8]) to set refresh interval.
- 6) Perform load-mode with MSR\_BA = 01 (MSR 200000018h[29:28] = 01) to initialize DIMM Extended Mode register. Load-mode is performed by setting/clearing PROG\_DRAM (MSR 200000018h[0]).
- 7) Set RST\_DLL (MSR 20000018h[27] = 1), perform second load-mode with MSR\_BA = 00 (MSR 20000018h[29:28]) to initialize Mode register and reset DLL.
- 8) Perform third load-mode (MSR 20000018h[29:28] = 00) and RST\_DLL cleared (MSR 20000018h[27] = 0).
- 9) Clear TRISTATE\_DIS (MSR 2000001Dh[12] = 0) to enable the GLMC TRI\_STATE during idle cycles (i.e., CS[3:0]# = Fh).
- 10) Wait at least 200 SDCLKs before performing the first read/write operation.

## 6.2 GeodeLink™ Memory Controller Register Descriptions

All GLMC registers are Model Specific Registers (MSRs) and are accessed via the RDMSR and WRMSR instructions.

The registers associated with the GLMC are the Standard GeodeLink Device (GLD) MSRs and GLMC Specific MSRs. Table 6-5 and Table 6-6 are register summary

tables that include reset values and page references where the bit descriptions are provided.

**Note:** MSR addresses are documented using the CPU Core as the source. Refer to Section 4.1 "MSR Set" on page 45 for further details.

**Table 6-5. Standard GeodeLink™ Device MSRs Summary**

MSR Address	Type	Register Name	Reset Value	Reference
20002000h	RO	GLD Capabilities MSR (GLD_MSR_CAP)	00000000_000204xxh	Page 220
20002001h	---	GLD Master Configuration MSR (GLD_MSR_CONFIG) - Not Used	00000000_00000000h	Page 220
20002002h	R/W	GLD SMI MSR (GLD_MSR_SMI)	00000000_00000000h	Page 220
20002003h	R/W	GLD Error MSR (GLD_MSR_ERROR)	00000000_00000000h	Page 221
20002004h	R/W	GLD Power Management (GLD_MSR_PM)	00000000_00000000h	Page 222
20002005h	R/W	GLD Diagnostic (GLD_MSR_DIAG)	00000000_00000000h	Page 222

**Table 6-6. GLMC Specific MSR Summary**

MSR Address	Type	Register Name	Reset Value	Reference
20000010h	RO	Row Addresses Bank0 DIMM0, Bank1 DIMM0 (MC_CF_BANK01)	xxxxxxxx_xxxxxxxh	Page 223
20000011h	RO	Row Addresses Bank2 DIMM0, Bank3 DIMM0 (MC_CF_BANK23)	xxxxxxxx_xxxxxxxh	Page 223
20000012h	RO	Row Addresses Bank4 DIMM0, Bank5 DIMM0 (MC_CF_BANK45)	xxxxxxxx_xxxxxxxh	Page 224
20000013h	RO	Row Addresses Bank6 DIMM0, Bank7 DIMM0 (MC_CF_BANK67)	xxxxxxxx_xxxxxxxh	Page 224
20000014h	RO	Row Addresses Bank0 DIMM1, Bank1 DIMM0 (MC_CF_BANK89)	xxxxxxxx_xxxxxxxh	Page 225
20000015h	RO	Row Addresses Bank2 DIMM1, Bank3 DIMM1 (MC_CF_BANKAB)	xxxxxxxx_xxxxxxxh	Page 225
20000016h	RO	Row Addresses Bank4 DIMM1, Bank5 DIMM1 (MC_CF_BANKCD)	xxxxxxxx_xxxxxxxh	Page 226
20000017	RO	Row Addresses Bank6 DIMM1, Bank7 DIMM1 (MC_CF_BANKEF)	xxxxxxxx_xxxxxxxh	Page 226
20000018h	R/W	Refresh and SDRAM Program (MC_CF07_DATA)	10071007_00000040h	Page 227
20000019h	R/W	Timing and Mode Program (MC_CF8F_DATA)	18000008_287337A3h	Page 229
2000001Ah	R/W	Feature Enables (MC_CF1017_DATA)	00000000_11080001h	Page 231
2000001Bh	RO	Performance Counters (MC_CFPERF_CNT1)	00000000_00000000h	Page 232
2000001Ch	R/W	Counter and CAS Control (MC_PERCNT2)	00000000_00FF00FFh	Page 233
2000001Dh	R/W	Clocking and Debug (MC_CFCLK_DEBUG)	00000000_00001300h	Page 233
2000001Eh	RO	Page Open Status (MC_CFPG_OPEN)	00000000_0000FFFFh	Page 235

Table 6-6. GLMC Specific MSR Summary

MSR Address	Type	Register Name	Reset Value	Reference
2000001Fh	---	Reserved	---	---
20000020h	R/W	PM Sensitivity Counters (MC_CF_PMCTR)	00000000_00000006h	Page 236

## 6.2.1 Standard GeodeLink™ Device (GLD) MSRs

### 6.2.1.1 GLD Capabilities MSR (GLD\_MSR\_CAP)

MSR Address 20002000h  
 Type RO  
 Reset Value 00000000\_000204xxh

#### GLD\_MSR\_CAP Register

63	62	61	60	59	58	57	56	55	54	53	52	51	50	49	48	47	46	45	44	43	42	41	40	39	38	37	36	35	34	33	32
RSVD																															
31	30	29	28	27	26	25	24	23	22	21	20	19	18	17	16	15	14	13	12	11	10	9	8	7	6	5	4	3	2	1	0
RSVD								DEV_ID																REV_ID							

#### GLD\_MSR\_CAP Bit Descriptions

Bit	Name	Description
63:24	RSVD	<b>Reserved.</b>
23:8	DEV_ID	<b>Device ID.</b> Identifies device (0204).
7:0	REV_ID	<b>Revision ID.</b> Identifies device revision. See <i>AMD Geode™ LX Processors Specification Update</i> document for value.

### 6.2.1.2 GLD Master Configuration MSR (GLD\_MSR\_CONFIG) - Not Used

MSR Address 20002001h  
 Type  
 Reset Value 00000000\_00000000h

This register is not used in the GLMC module.

### 6.2.1.3 GLD SMI MSR (GLD\_MSR\_SMI)

MSR Address 20002002h  
 Type R/W  
 Reset Value 00000000\_00000000h

This register is not used in the GLMC module

**6.2.1.4 GLD Error MSR (GLD\_MSR\_ERROR)**

MSR Address 20002003h  
 Type R/W  
 Reset Value 00000000\_00000000h

**GLD\_MSR\_ERROR Register Map**

63	62	61	60	59	58	57	56	55	54	53	52	51	50	49	48	47	46	45	44	43	42	41	40	39	38	37	36	35	34	33	32	
RSVD																																
31	30	29	28	27	26	25	24	23	22	21	20	19	18	17	16	15	14	13	12	11	10	9	8	7	6	5	4	3	2	1	0	
ERRVAL[15:1] (RSVD)																ERR_VAL0	ERRMAS[15:1] (RSVD)															ERR_MASK0

**GLD\_MSR\_ERROR Bit Descriptions**

Bit	Name	Description
63:32	RSVD	<b>Reserved.</b>
31:17	RSVD	<b>Reserved.</b>
16	ERR_VAL0	<b>Error Value 0.</b> Synchronous error flag, sent out with GLIU response packet. Hardware sets error value; writes of 1 clears the error. The GLMC only implements the ‘type-exception’ error on bit 16, which is set when the GLIU request’s type field is either an I/O type or snoop type. This bit will be set on such error condition, regardless of the value of ERR_MASK0. An asynchronous error is also flagged via the mb_p_err output signal.  Note that when an error condition exists, the response packet that corresponds with the GLIU request that caused the error may be returned to the GLIU out of order (i.e., ahead of response data for older, outstanding requests in the GLMC). Moreover, the older, outstanding requests may return corrupt data. (Default = 0)
15:1	RSVD	<b>Reserved.</b>
0	ERR_MASK0	<b>Error Mask 0.</b> Masks the corresponding error in bit 16. The GLMC only implements error mask 0 that corresponds to error bit 16. This bit masks the reporting of the error event recorded in bit 16. (Default = 0h)

**6.2.1.5 GLD Power Management (GLD\_MSR\_PM)**

MSR Address 20002004h  
 Type R/W  
 Reset Value 00000000\_00000000h

**GLD\_MSR\_PM Register Map**

63	62	61	60	59	58	57	56	55	54	53	52	51	50	49	48	47	46	45	44	43	42	41	40	39	38	37	36	35	34	33	32	
RSVD																																
31	30	29	28	27	26	25	24	23	22	21	20	19	18	17	16	15	14	13	12	11	10	9	8	7	6	5	4	3	2	1	0	
RSVD																														PM1	RSVD	PM0

**GLD\_MSR\_PM Bit Descriptions**

Bit	Name	Description
63:32	RSVD (RO)	<b>Reserved (Read Only).</b> Reads back 0s.
31:3	RSVD	<b>Reserved.</b>
2	PM1	<b>Power Mode 1.</b> Clock gating for clock domains 0 (GLIU clock) and 1 (GLMC clock). Once the GLMC becomes idle, it enters PMode1 by 1) closing all banks with a 'precharge all' command to the DIMMs, 2) issuing a self-refresh command, 3) bringing CKE1 and CKE0 (balls F4 and E4 respectively) low and putting the address and control pins in TRI_STATE mode, and 4) shutting off its GLIU and GLMC clocks on the next clock after the self-refresh. The GLMC resumes to full power after any activity is detected (i.e., a GLIU request after reset).  0: Disable clock gating. Clocks are always ON. (Default) 1: Enable active hardware clock gating.
1	RSVD	<b>Reserved.</b>
0	PM0	<b>Power Mode 0.</b> Clock gating for clock domain 0 (GLIU clock). Once the GLMC becomes idle, it enters PMode0 by shutting off its GLIU clock on the next cycle. Its GLMC clock remains on to maintain the refresh counters, as do the SDRAM clocks. The GLMC resumes full power either after any activity is detected, or when it needs to perform a refresh.  0: Disable clock gating. Clocks are always ON. (Default) 1: Enable active hardware clock gating.

**6.2.1.6 GLD Diagnostic (GLD\_MSR\_DIAG)**

MSR Address 20002005h  
 Type R/W  
 Reset Value 00000000\_00000000h

This register is reserved for internal use by AMD and should not be written to.

## 6.2.2 GLMC Specific MSRs

### 6.2.2.1 Row Addresses Bank0 DIMM0, Bank1 DIMM0 (MC\_CF\_BANK01)

MSR Address 20000010h  
 Type RO  
 Reset Value xxxxxxxx\_xxxxxxxh

**MC\_CF\_BANK01 Register Map**

63	62	61	60	59	58	57	56	55	54	53	52	51	50	49	48	47	46	45	44	43	42	41	40	39	38	37	36	35	34	33	32
RSVD											MC_CF_BANK1																				
31	30	29	28	27	26	25	24	23	22	21	20	19	18	17	16	15	14	13	12	11	10	9	8	7	6	5	4	3	2	1	0
RSVD											MC_CF_BANK0																				

**MC\_CF\_BANK01 Bit Descriptions**

Bit	Name	Description
63:54	RSVD	<b>Reserved.</b> Reads back as 0.
53:32	MC_CF_BANK1	<b>Memory Configuration Back 1.</b> Open row address (31:10) for Bank1, DIMM0.
31:22	RSVD	<b>Reserved.</b> Reads back as 0.
21:0	MC_CF_BANK0	<b>Memory Configuration Back 0.</b> Open row address (31:10) for Bank0, DIMM0.

### 6.2.2.2 Row Addresses Bank2 DIMM0, Bank3 DIMM0 (MC\_CF\_BANK23)

MSR Address 20000011h  
 Type RO  
 Reset Value xxxxxxxx\_xxxxxxxh

**MC\_CF\_BANK23 Register Map**

63	62	61	60	59	58	57	56	55	54	53	52	51	50	49	48	47	46	45	44	43	42	41	40	39	38	37	36	35	34	33	32
RSVD											MC_CF_BANK3																				
31	30	29	28	27	26	25	24	23	22	21	20	19	18	17	16	15	14	13	12	11	10	9	8	7	6	5	4	3	2	1	0
RSVD											MC_CF_BANK2																				

**MC\_CF\_BANK23 Bit Descriptions**

Bit	Name	Description
63:54	RSVD	<b>Reserved.</b> Reads back as 0.
53:32	MC_CF_BANK3	<b>Memory Controller Configuration Bank 3.</b> Open row address (31:10) for Bank3, DIMM0.
31:22	RSVD	<b>Reserved.</b> Reads back as 0.
21:0	MC_CF_BANK2	<b>Memory Controller Configuration Bank 2.</b> Open row address (31:10) for Bank2, DIMM0.

**6.2.2.3 Row Addresses Bank4 DIMM0, Bank5 DIMM0 (MC\_CF\_BANK45)**

MSR Address 20000012h  
 Type RO  
 Reset Value xxxxxxxx\_xxxxxxxh

**MC\_CF\_BANK45 Register Map**

63	62	61	60	59	58	57	56	55	54	53	52	51	50	49	48	47	46	45	44	43	42	41	40	39	38	37	36	35	34	33	32
RSVD										MC_CF_BANK5																					
31	30	29	28	27	26	25	24	23	22	21	20	19	18	17	16	15	14	13	12	11	10	9	8	7	6	5	4	3	2	1	0
RSVD										MC_CF_BANK4																					

**MC\_CF\_BANK45 Bit Descriptions**

Bit	Name	Description
63:54	RSVD	<b>Reserved.</b> Reads back as 0.
53:32	MC_CF_BANK5	<b>Memory Controller Configuration Bank 5.</b> Open row address (31:10) for Bank5, DIMM0.
31:22	RSVD	<b>Reserved.</b> Reads back as 0.
21:0	MC_CF_BANK4	<b>Memory Controller Configuration Bank 4.</b> Open row address (31:10) for Bank4, DIMM0.

**6.2.2.4 Row Addresses Bank6 DIMM0, Bank7 DIMM0 (MC\_CF\_BANK67)**

MSR Address 20000013h  
 Type RO  
 Reset Value xxxxxxxx\_xxxxxxxh

**MC\_CF\_BANK67 Register Map**

63	62	61	60	59	58	57	56	55	54	53	52	51	50	49	48	47	46	45	44	43	42	41	40	39	38	37	36	35	34	33	32
RSVD										MC_CF_BANK7																					
31	30	29	28	27	26	25	24	23	22	21	20	19	18	17	16	15	14	13	12	11	10	9	8	7	6	5	4	3	2	1	0
RSVD										MC_CF_BANK6																					

**MC\_CF\_BANK67 Bit Descriptions**

Bit	Name	Description
63:54	RSVD	<b>Reserved.</b> Reads back as 0.
53:32	MC_CF_BANK7	<b>Memory Controller Configuration Bank 7.</b> Open row address (31:10) for Bank7, DIMM0.
31:22	RSVD	<b>Reserved.</b> Reads back as 0.
21:0	MC_CF_BANK6	<b>Memory Controller Configuration Bank 6.</b> Open row address (31:10) for Bank6, DIMM0.



**6.2.2.5 Row Addresses Bank0 DIMM1, Bank1 DIMM0 (MC\_CF\_BANK89)**

MSR Address 20000014h  
 Type RO  
 Reset Value xxxxxxxx\_xxxxxxxh

**MC\_CF\_BANK89 Register Map**

63	62	61	60	59	58	57	56	55	54	53	52	51	50	49	48	47	46	45	44	43	42	41	40	39	38	37	36	35	34	33	32
RSVD										MC_CF_BANK9																					
31	30	29	28	27	26	25	24	23	22	21	20	19	18	17	16	15	14	13	12	11	10	9	8	7	6	5	4	3	2	1	0
RSVD										MC_CF_BANK8																					

**MC\_CF\_BANK89 Bit Descriptions**

Bit	Name	Description
63:54	RSVD	<b>Reserved.</b> Reads back as 0.
53:32	MC_CF_BANK9	<b>Memory Controller Configuration Bank 9.</b> Open row address (31:10) for Bank1, DIMM1.
31:22	RSVD	<b>Reserved.</b> Reads back as 0.
21:0	MC_CF_BANK8	<b>Memory Controller Configuration Bank 8.</b> Open row address (31:10) for Bank0, DIMM1.

**6.2.2.6 Row Addresses Bank2 DIMM1, Bank3 DIMM1 (MC\_CF\_BANKAB)**

MSR Address 20000015h  
 Type RO  
 Reset Value xxxxxxxx\_xxxxxxxh

**MC\_CF\_BANKAB Register Map**

63	62	61	60	59	58	57	56	55	54	53	52	51	50	49	48	47	46	45	44	43	42	41	40	39	38	37	36	35	34	33	32
RSVD										MC_CF_BANKB																					
31	30	29	28	27	26	25	24	23	22	21	20	19	18	17	16	15	14	13	12	11	10	9	8	7	6	5	4	3	2	1	0
RSVD										MC_CF_BANKA																					

**MC\_CF\_BANKAB Bit Descriptions**

Bit	Name	Description
63:54	RSVD	<b>Reserved.</b> Reads back as 0.
53:32	MC_CF_BANKB	<b>Memory Controller Configuration Bank B.</b> Open row address (31:10) for Bank3, DIMM1.
31:22	RSVD	<b>Reserved.</b> Reads back as 0.
21:0	MC_CF_BANKA	<b>Memory Controller Configuration Bank A.</b> Open row address (31:10) for Bank2, DIMM1.

**6.2.2.7 Row Addresses Bank4 DIMM1, Bank5 DIMM1 (MC\_CF\_BANKCD)**

MSR Address 20000016h  
 Type RO  
 Reset Value xxxxxxxx\_xxxxxxxh

**MC\_CF\_BANKCD Register Map**

63	62	61	60	59	58	57	56	55	54	53	52	51	50	49	48	47	46	45	44	43	42	41	40	39	38	37	36	35	34	33	32
RSVD										MC_CF_BANKD																					
31	30	29	28	27	26	25	24	23	22	21	20	19	18	17	16	15	14	13	12	11	10	9	8	7	6	5	4	3	2	1	0
RSVD										MC_CF_BANKC																					

**MC\_CF\_BANKCD Bit Descriptions**

Bit	Name	Description
63:54	RSVD	<b>Reserved.</b> Reads back as 0.
53:32	MC_CF_BANKD	<b>Memory Controller Configuration Bank C.</b> Open row address (31:10) for Bank5, DIMM1.
31:22	RSVD	<b>Reserved.</b> Reads back as 0.
21:0	MC_CF_BANKC	<b>Memory Controller Configuration Bank B.</b> Open row address (31:10) for Bank4, DIMM1.

**6.2.2.8 Row Addresses Bank6 DIMM1, Bank7 DIMM1 (MC\_CF\_BANKEF)**

MSR Address 20000017  
 Type RO  
 Reset Value xxxxxxxx\_xxxxxxxh

**MC\_CF\_BANKEF Register Map**

63	62	61	60	59	58	57	56	55	54	53	52	51	50	49	48	47	46	45	44	43	42	41	40	39	38	37	36	35	34	33	32
RSVD										MC_CF_BANKF																					
31	30	29	28	27	26	25	24	23	22	21	20	19	18	17	16	15	14	13	12	11	10	9	8	7	6	5	4	3	2	1	0
RSVD										MC_CF_BANKE																					

**MC\_CF\_BANKEF Bit Descriptions**

Bit	Name	Description
63:54	RSVD	<b>Reserved.</b> Reads back as 0.
53:32	MC_CF_BANKF	<b>Memory Controller Configuration Bank F.</b> Open row address (31:10) for Bank7, DIMM1.
31:22	RSVD	<b>Reserved.</b> Reads back as 0.
21:0	MC_CF_BANKE	<b>Memory Controller Configuration Bank E.</b> Open row address (31:10) for Bank6, DIMM1.

**6.2.2.9 Refresh and SDRAM Program (MC\_CF07\_DATA)**

MSR Address 20000018h  
 Type R/W  
 Reset Value 10071007\_00000040h

**MC\_CF07\_DATA Register Map**

63	62	61	60	59	58	57	56	55	54	53	52	51	50	49	48	47	46	45	44	43	42	41	40	39	38	37	36	35	34	33	32	
D1_SZ				RSVD			D1_MB	RSVD			D1_CB	RSVD	D1_PSZ			D0_SZ			RSVD			D0_MB	RSVD			D0_CB	RSVD	D0_PSZ				
31	30	29	28	27	26	25	24	23	22	21	20	19	18	17	16	15	14	13	12	11	10	9	8	7	6	5	4	3	2	1	0	
RSVD		MSR_BA		RST_DLL		EMR_QFC		EMR_DRV		EMR_DLL		REF_INT											REF_STAG			REF_TST		RSVD		SOFT_RST		PROG_DRAM

**MC\_CF07\_DATA Bit Descriptions**

Bit	Name	Description
63:60	D1_SZ	<b>DIMM1 Size.</b> 0000: Reserved                      0100: 64 MB                      1000: 1 GB 0001: 8 MB (Default)              0101: 128 MB                    1001-1111: Reserved 0010: 16 MB                            0110: 256 MB 0011: 32 MB                            0111: 512 MB
59:57	RSVD	<b>Reserved.</b>
56	D1_MB	<b>DIMM1 Module Banks.</b> Number of module banks for DIMM1. 0: 1 Module bank. (Default) 1: 2 Module banks.
55:53	RSVD	<b>Reserved.</b>
52	D1_CB	<b>DIMM1 Component Banks.</b> Number of component banks per module bank for DIMM1. 0: 2 Component banks. (Default) 1: 4 Component banks.
51	RSVD	<b>Reserved.</b>
50:48	D1_PSZ	<b>DIMM1 Page Size.</b> 000: 1 KB                                      100: 16 KB 001: 2 KB                                      101: 32 KB 010: 4 KB                                      110: Reserved 011: 8 KB                                      111: DIMM 1 Not Installed (Default)
47:44	D0_SZ	<b>DIMM0 Size.</b> 0000: Reserved                      0100: 64 MB                      1000: 1 GB 0001: 8 MB (Default)              0101: 128 MB                    1001-1111: Reserved 0010: 16 MB                            0110: 256 MB 0011: 32 MB                            0111: 512 MB
43:41	RSVD	<b>Reserved.</b>
40	D0_MB	<b>DIMM0 Module Banks.</b> Number of module banks for DIMM0. 0: 1 Module bank. (Default) 1: 2 Module banks.
39:37	RSVD	<b>Reserved.</b>

## MC\_CF07\_DATA Bit Descriptions (Continued)

Bit	Name	Description
36	D0_CB	<b>DIMM0 Component Banks.</b> Number of component banks per module bank for DIMM0. 0: 2 Component banks. (Default) 1: 4 Component banks.
35	RSVD	<b>Reserved.</b>
34:32	D0_PSZ	<b>DIMM0 Page Size.</b> 000: 1 KB                      100: 16 KB 001: 2 KB                      101: 32 KB 010: 4 KB                      110: Reserved 011: 8 KB                      111: DIMM0 Not Installed (Default)
31:30	RSVD	<b>Reserved.</b>
29:28	MSR_BA	<b>Mode Register Set Bank Address.</b> These are the bank select bits used for programming the DDR DIMM's Extended Mode Register. These bits select whether the GLMC is programming the Mode Register or the Extended Mode Register. 00: Program the DIMM Mode Register. (Default) 01: Program the DIMM Extended Mode Register. Bits [26:24] determine the program data. 10: Reserved. 11: Reserved.
27	RST_DLL	<b>Mode Register Reset DLL.</b> This bit represents A8 in the Mode Register, which when set to 1 resets the DLL as part of the DIMM initialization sequence. JEDEC recommends clearing this bit back to 0 on the final load-mode-register command before activating any bank. 0: Do not reset DLL. (Default) 1: Reset DLL.
26	EMR_QFC	<b>Extended Mode Register FET Control.</b> This bit programs the DIMM's QFC# signal. The QFC# signal provides control for FET switches that are used to isolate module loads from the system memory busy at times when the given module is not being accessed. Only pertains to x4 configurations. 0: Enable. (Default) 1: Disable.
25	EMR_DRV	<b>Extended Mode Register Drive Strength Control.</b> This bit selects either normal or reduced drive strength. 0: Normal. (Default) 1: Reduced.
24	EMR_DLL	<b>Extended Mode Register DLL.</b> This bit disables/enables the DLL. 0: Enable. (Default) 1: Disable.
23:8	REF_INT	<b>Refresh Interval.</b> This field determines the number of SDRAM clocks between refresh. This value multiplied by 16 is the average number of clocks between refresh. The default value, 00h, disables refresh.
7:4	REF_STAG	<b>Refresh Staggering.</b> This field controls the number of clocks (0-16) between REF commands to different banks during refresh cycles. Staggering is used to help reduce power spikes during refresh. Note that with a setting of 0, no staggering occurs, so all module banks are refreshed simultaneously. (Default = 1)
3	REF_TST	<b>Test Refresh.</b> This bit, when set high, generates one refresh request that the GLMC queues in its refresh request queue. Since the refresh queue is 8-deep, 8 sets/clears of this bit queues 8 refresh requests, thus forcing a refresh request out to DRAM. This bit should only be used for initialization and test. (Default = 0)

**MC\_CF07\_DATA Bit Descriptions (Continued)**

Bit	Name	Description
2	RSVD	<b>Reserved.</b>
1	SOFT_RST	<p><b>Software Reset.</b> Puts the GLMC in a known state. Does not change configuration registers. The recommended sequence to use is:</p> <ol style="list-style-type: none"> <li>1) Make sure SDRAM interface has “been idle for a while”.</li> <li>2) Set software reset, then clear software reset.</li> <li>3) Do a refresh cycle.</li> </ol> <p>Accesses to memory may resume as normal following this.</p> <p>Note that configuration registers are not scannable. To reproduce a problem in simulation requires saving the configuration registers with software in silicon and reprogramming the values in simulation. (Default = 0)</p>
0	PROG_DRAM	<p><b>Program Mode Register in SDRAM.</b> When this bit is set, the GLMC will issue one Load Mode Register command to the DRAMs. It either programs the Mode Register (if MSR_BA, bits [29:28] = 00), or the Extended Mode Register (if MSR_BA, bits [29:28] = 01). The Mode Register is programmed with CAS latency (see MSR 2000019h[30:28]), wrap type sequential, and burst length of 4 for 64-bit data path, or burst length of 8 for 32-bit wide data path. The Extended Mode Register in DDR DIMMs is programmed with the QFC#, drive strength and DLL disable bits [26:24]. The Extended Mode Register must be programmed first to enable the DLLs, then the Mode Register. This bit must be set and cleared for each Load Mode Register command. (Default = 0)</p>

**6.2.2.10 Timing and Mode Program (MC\_CF8F\_DATA)**

MSR Address     20000019h  
 Type            R/W  
 Reset Value    18000008\_287337A3h

**MC\_CF8F\_DATA Register Map**

63	62	61	60	59	58	57	56	55	54	53	52	51	50	49	48	47	46	45	44	43	42	41	40	39	38	37	36	35	34	33	32		
STALE_REQ								RSVD				XOR_BIT_SEL	XOR_MBO	XOR_BA1	XOR_BA0	RSVD							TRUNC_DIS	REORDER_DIS	RSVD							HOI_LOI	RSVD
31	30	29	28	27	26	25	24	23	22	21	20	19	18	17	16	15	14	13	12	11	10	9	8	7	6	5	4	3	2	1	0		
THZ_DLY	CAS_LAT	ACT2ACTREF		ACT2PRE				RSVD	PRE2ACT				RSVD	ACT2CMD		ACT2ACT			DPLWR		DPLRD		RSVD										

## MC\_CF8F\_DATA Bit Descriptions

Bit	Name	Description
63:56	STALE_REQ	<b>GLIU Max Stale Request Count.</b> Non-high priority requests (PRI = 0) are made high-priority requests when the request is not serviced within max stale request count clocks. (Default = 18h)
55:53	RSVD	<b>Reserved.</b>
52:51	XOR_BIT_SEL	<b>XOR Bit Select.</b> Selects which upper GLIU address bit to XOR with MB0, BA1 or BA0 (see "Auto Low Order Interleaving" on page 212). Only applies to LOI mode. (Default = 00). 00: ADDR[18] 01: ADDR[19] 10: ADDR[20] 11: ADDR[21]
50	XOR_MB0	<b>XOR MB0 Enable.</b> Enables XORing of module bank select MB0 with upper GLIU address bit selected by XOR_BIT_SEL (bits [52:51]). (Default = 0, Disabled)
49	XOR_BA1	<b>XOR BA1 Enable.</b> Enables XORing of component bank select BA1 with upper GLIU address bit selected by XOR_BIT_SEL (bits [52:51]). (Default = 0, Disabled)
48	XOR_BA0	<b>XOR BA0 Enable.</b> Enables XORing of component bank select BA0 with upper GLIU address bit selected by XOR_BIT_SEL (bits [52:51]). (Default = 0, Disabled)
47:42	RSVD	<b>Reserved.</b>
41	TRUNC_DIS	<b>Burst Truncate Disable.</b> Disables truncation of read/write bursts. This disable reduces performance and should only be used during debug. (Default = 0, bursts enabled)
40	REORDER_DIS	<b>Reorder Disable.</b> Disables the reordering of requests. This bit must be set to 1.
39:34	RSVD	<b>Reserved.</b>
33	HOI_LOI	<b>High / Low Order Interleave Select (HOI / LOI).</b> Selects the address interleaving mode. HOI uses fixed upper address bits to map the GLIU address to a component bank. LOI uses variable lower address bits depending on page size, number of module banks, and number of component banks of the DIMMs, plus an option to XOR with upper address bits. 1: HOI. 0: LOI. (Default)
32	RSVD	<b>Reserved.</b>
31	THZ_DLY	<b>tHZ Delay.</b> Add 1 extra clock on read-to-write turnarounds to satisfy DRAM parameter $t_{HZ}$ for higher frequencies. (Default = 0)
30:28	CAS_LAT	<b>Read CAS Latency.</b> Number of clock delays between Read command and Data valid. CAS Latency: 000: RSVD      010: 2 (Default)      100: 4      110: 2.5 001: RSVD      011: 3      101: 1.5      111: 3.5
27:24	ACT2ACTREF	<b>ACT to ACT/REF Period.</b> tRC. Minimum number of SDRAM clocks between ACTIVE and ACTIVE/AUTO REFRESH commands. (Default = 8h)
23:20	ACT2PRE	<b>ACT to PRE Period.</b> tRAS. Minimum number of clocks from ACT to PRE commands on the same component bank. (Default = 7h)
19	RSVD	<b>Reserved.</b>
18:16	PRE2ACT	<b>Pre to Act Period.</b> tRP. Minimum number of SDRAM clocks between PRE and ACT commands. (Default = 011)
15	RSVD	<b>Reserved.</b>
14:12	ACT2CMD	<b>Delay Time from Act To read/WRITE.</b> tRCD. Minimum number of SDRAM clocks between ACT and READ/WRITE commands. (6..2 valid). (Default = 011)

## MC\_CF8F\_DATA Bit Descriptions (Continued)

Bit	Name	Description
11:8	ACT2ACT	<b>ACT(0) to ACT(1) Period.</b> tRRD. Minimum number of SDRAM clocks between ACT and ACT command to two different component banks within the same module bank. (Default = 7h)
7:6	DPLWR	<b>Data-in to PRE Period.</b> tDPLW. Minimum number of clocks from last write data to pre-charge command on the same component bank. (3..1 valid). Default = 10)
5:4	DPLRD	<b>Data-in to PRE Period.</b> tDPLR. Minimum number of clocks from last read data to pre-charge command on the same component bank.(3..1 valid) The count starts on the same clock that the last data would have been if the command was a write. (Default = 10)
3	RSVD	<b>Reserved.</b>
2:0	RSVD	<b>Reserved.</b>

## 6.2.2.11 Feature Enables (MC\_CF1017\_DATA)

MSR Address 2000001Ah  
 Type R/W  
 Reset Value 00000000\_11080001h

## MC\_CF1017\_DATA Register Map

63	62	61	60	59	58	57	56	55	54	53	52	51	50	49	48	47	46	45	44	43	42	41	40	39	38	37	36	35	34	33	32					
RSVD																																				
31	30	29	28	27	26	25	24	23	22	21	20	19	18	17	16	15	14	13	12	11	10	9	8	7	6	5	4	3	2	1	0					
RSVD	WR_TO_RD	RSVD	RD_TMG_CTL	RSVD	REF2ACT	PM1_UP_DLY	RSVD	WR2DAT																												

## MC\_CF1017\_DATA Bit Descriptions

Bit	Name	Description
63:30	RSVD	<b>Reserved.</b>
29:28	WRITE_TO_RD	<b>Write to Read Delay.</b> tWTR. Minimum number of SDCLKS between last write data beat to next read command. (Default = 01)
27	RSVD	<b>Reserved.</b>
26:24	RD_TMG_CTL	<b>Read Timing Control.</b> Number of half-GLIU clocks that the read data is delayed in arriving at the GLMC beyond the CAS latency delay. This number increases as the round-trip read delay increases. (Default = 001)
23:21	RSVD	<b>Reserved.</b>
20:16	REF2ACT	<b>Refresh to Activate Delay.</b> tRFC. Minimum number of SDCLKS (0-31) between refresh and next command, usually an activate. (Default = 8h)
15:8	PM1_UP_DLY	<b>PMode1 Up Delay.</b> Sets the delay in DRAM clocks from exit from PMode1 to acceptance of the next GLIU memory request. PMode1 power down involves a self-refresh command to DRAM. This is to satisfy a 200-clock delay from self-refresh exit to first read command (although this bit will delay all commands, read and write). (Default = 0, No delay)
7:3	RSVD	<b>Reserved.</b>

**MC\_CF1017\_DATA Bit Descriptions**

Bit	Name	Description
2:0	WR2DAT	<b>Write Command To Data Latency.</b> Number of clocks between the write command and the first data beat. Valid values are: [2,1,0], and must correspond to the installed DIMMs as follows: 0h: No delay. 1h: 1-clock delay for DDR unbuffered DIMMs. (Default)

**6.2.2.12 Performance Counters (MC\_CFPERF\_CNT1)**

MSR Address 2000001Bh  
 Type RO  
 Reset Value 00000000\_00000000h

**MC\_CFPERF\_CNT1 Register Map**

63	62	61	60	59	58	57	56	55	54	53	52	51	50	49	48	47	46	45	44	43	42	41	40	39	38	37	36	35	34	33	32
CNT1																															
31	30	29	28	27	26	25	24	23	22	21	20	19	18	17	16	15	14	13	12	11	10	9	8	7	6	5	4	3	2	1	0
CNT0																															

**MC\_CFPERF\_CNT1 Bit Descriptions**

Bit	Name	Description
63:32	CNT0	<b>Counter 0.</b> Performance counter 0. Counts the occurrence of events at the GLIU interface. Events are specified in CNT0_DATA (MSR 2000001Ch[7:0]). Reset and stop control on this counter is done via MSR 200001Ch[33:32]. (Default = 0h)
31:0	CNT1	<b>Counter 1.</b> Performance counter 1. Counts the occurrence of events at the GLIU interface. Events are specified in CNT1_DATA (MSR 2000001Ch[23:16]). Reset and stop control on this counter is done via MSR 200001Ch[35:34]. (Default = 0h)



**6.2.2.13 Counter and CAS Control (MC\_PERCNT2)**

MSR Address 2000001Ch  
 Type R/W  
 Reset Value 00000000\_00FF00FFh

**MC\_PERCNT2 Register Map**

63	62	61	60	59	58	57	56	55	54	53	52	51	50	49	48	47	46	45	44	43	42	41	40	39	38	37	36	35	34	33	32						
RSVD																																		STOP_CNT1	RST_CNT1	STOP_CNT0	RST_CNT0
31	30	29	28	27	26	25	24	23	22	21	20	19	18	17	16	15	14	13	12	11	10	9	8	7	6	5	4	3	2	1	0						
RSVD																																					

**MC\_PERCNT2 Bit Descriptions**

Bit	Name	Description
63:36	RSVD	<b>Reserved.</b>
35	STOP_CNT1	<b>Stop Counter 1.</b> If set, stops counter 1. (Default = 0)
34	RST_CNT1	<b>Reset Counter 1.</b> If set, resets counter 1. (Default = 0)
33	STOP_CNT0	<b>Stop Counter 0.</b> If set, stops counter 0. (Default = 0)
32	RST_CNT0	<b>Reset Counter 0.</b> If set, resets counter 0. (Default = 0)
31:0	RSVD	<b>Reserved.</b>

**6.2.2.14 Clocking and Debug (MC\_CFCLK\_DEBUG)**

MSR Address 2000001Dh  
 Type R/W  
 Reset Value 00000000\_00001300h

**MC\_CFCLK\_DEBUG Register Map**

63	62	61	60	59	58	57	56	55	54	53	52	51	50	49	48	47	46	45	44	43	42	41	40	39	38	37	36	35	34	33	32										
RSVD																																		B2B_DIS	MTEST_RBEX_EN	MTEST_EN					
31	30	29	28	27	26	25	24	23	22	21	20	19	18	17	16	15	14	13	12	11	10	9	8	7	6	5	4	3	2	1	0										
RSVD																FORCE_PRE	RSVD			TRISTATE_DIS	RSVD		MASK_CKE1	MASK_CKE0	CNTL_MSK1	CNTL_MSK0	ADRS_MSK	RSVD													

## MC\_CFCLK\_DEBUG Bit Descriptions

Bit	Name	Description
63:35	RSVD	<b>Reserved.</b>
34	B2B_DIS	<b>Back-to-Back Command Disable.</b> Setting this bit disables the issuing of DRAM commands within back-to-back cycles in both MTEST and normal functional mode. To maximize performance, this should only be used in MTEST mode, where the cycle following the command cycle should be idle for the logic analyzer to be able to properly capture and interpret the MTEST data. (Default = 0) (back-to-back commands allowed).
33	MTEST_RBEX_EN	<b>MTEST RBEX Enable.</b> Enables the outputting of read byte enables information on reads with RBEXs. 0: Disable. (Default) 1: Enable.
32	MTEST_EN	<b>MTEST Enable.</b> Enables MTEST debug mode, which multiplexes debug data onto the 13 DRAM address output pins, one cycle after the command cycle. (Default = 0)
31:17	RSVD	<b>Reserved.</b>
16	FORCE_PRE	<b>Force Precharge-all.</b> Force precharge-all command before load-mode and refresh commands, even when banks are already all closed. Normally, a precharge-all command only gets issued conditionally before a load-mode or refresh command: only if the module banks are not all closed yet. With this bit set, the precharge-all will be issued unconditionally before the load-mode or refresh command. 0: Disable. (Default) 1: Enable.
15:13	RSVD	<b>Reserved.</b>
12	TRISTATE_DIS	<b>TRI-STATE Disable.</b> This bit controls the power saving feature that puts the GLMC's address and control pins into TRI-STATE mode during idle cycles or during PMode1. 0: Tri-stating enabled. 1: Tri-stating disabled. (Default)
11:10	RSVD	<b>Reserved.</b>
9:8	MASK_CKE[1:0]	<b>CKE Mask.</b> Mask output enables for CKE[1:0]. After power-up or warm reset, software can complete all necessary initialization tasks before clearing this mask to allow communication with the DRAM. These bits can also be used to selectively mask off the CKE signal of a DIMM that is not installed. 00: CKE1 and CKE0 unmasked. 01: CKE1 unmasked, CKE0 masked. 10: CKE1 masked, CKE0 unmasked. 11: CKE1 and CKE0 masked. (Default)
7	CNTL_MSK1	<b>Control Mask 1.</b> Mask output enable bit for DIMM1's CAS1#, RAS1#, WE1#, CS[3:2]#. 0: Unmasked. (Default) 1: Masked.
6	CNTL_MSK0	<b>Control Mask 0.</b> Mask output enable bit for DIMM0's CAS0#, RAS0#, W0#, CS[1:0]#. 0: Unmasked. (Default) 1: Masked.
5	ADRS_MSK	<b>Address Mask.</b> Mask output enable bit for MA and BA. (Default = 0)
4:0	RSVD	<b>Reserved.</b>

**6.2.2.15 Page Open Status (MC\_CFPG\_OPEN)**

MSR Address 2000001Eh  
 Type RO  
 Reset Value 00000000\_0000FFFFh

**MC\_CFPG\_OPEN Register Map**

63	62	61	60	59	58	57	56	55	54	53	52	51	50	49	48	47	46	45	44	43	42	41	40	39	38	37	36	35	34	33	32
RSVD																															
31	30	29	28	27	26	25	24	23	22	21	20	19	18	17	16	15	14	13	12	11	10	9	8	7	6	5	4	3	2	1	0
RSVD																PGOPEN1								PGOPEN0							

**MC\_CFPG\_OPEN Bit Descriptions**

Bit	Name	Description
63:16	RSVD	<b>Reserved.</b> Reads back as 0.
15:8	PGOPEN1	<b>Page Open DIMM 1.</b> Page open indication of the second DIMM. Each bit position represents a page and a 1 indicates an open page. All pages are initialized 'open'. After reset, a 'precharge all' command closes all the banks.
7:0	PGOPEN0	<b>Page Open DIMM 0.</b> Page open indication of the first DIMM. Each bit position represents a page and a 1 indicates an open page. All pages are initialized 'open'. After reset, a 'precharge all' command closes all the banks.

**6.2.2.16 Reserved Register**

MSR Address 2000001Fh  
 Type RW  
 Reset Value 00000000\_00000000h

This register is reserved and should not be written to.

**6.2.2.17 PM Sensitivity Counters (MC\_CF\_PMCTR)**

MSR Address 20000020h  
 Type R/W  
 Reset Value 00000000\_00000006h

**MC\_CF\_PMCTR Register Map**

63	62	61	60	59	58	57	56	55	54	53	52	51	50	49	48	47	46	45	44	43	42	41	40	39	38	37	36	35	34	33	32
PM1_SENS																															
31	30	29	28	27	26	25	24	23	22	21	20	19	18	17	16	15	14	13	12	11	10	9	8	7	6	5	4	3	2	1	0
PM0_SENS																															

**MC\_CF\_PMCTR Bit Descriptions**

Bit	Name	Description
63:32	PM1_SENS	<b>PMode1 Sensitivity Counter.</b> Counter that controls the GLMC's sensitivity to entering PMode1 power down mode. If PMode1 is enabled, PM1_SENS starts counting down from its loaded value whenever the GLMC becomes idle. If it times out and the GLMC is still idle, the GLMC goes into PMode1. If, however, the GLMC resumes activity before time-out, the counter is reset to its loaded value and PMode1 is not entered. (Default = 0h)
31:0	PM0_SENS	<b>PMode0 Sensitivity Counter.</b> Counter that controls the GLMC's sensitivity to entering PMode0 power down mode. If PMode0 is enabled, PM0_SENS starts counting down from its loaded value whenever the GLMC becomes idle. If it times out and the GLMC is still idle, the GLMC goes into PMode0. If, however, the GLMC resumes activity before time-out, the counter is reset to its loaded value and PMode0 is not entered. (Default = 6h, to allow 32-bit bursts to finish).

### 6.3 Graphics Processor

The Graphics Processor is based on the graphics processor used in the AMD Geode™ GX processor with several features added to enhance performance and functionality. Like its predecessor, the AMD Geode LX processor's Graphics Processor is a BitBLT/vector engine that supports pattern generation, source expansion, pattern/source transparency, 256 ternary raster operations, alpha blenders to support alpha-BLTs, incorporated BLT FIFOs, a GeodeLink™ interface and the ability to throttle BLTs according to video timing. Features added to the Graphics Processor include:

- Command buffer interface
- Hardware accelerated rotation BLTs

- Color depth conversion
- Palletized color
- Full 8x8 color pattern buffer
- Channel 3 - third DMA channel
- Monochrome inversion

The block diagram of the AMD Geode LX processor's Graphics Processor is shown in Figure 6-10. Table 6-7 on page 238 presents a comparison between the Graphics Processor features of the AMD Geode GX and LX processors.

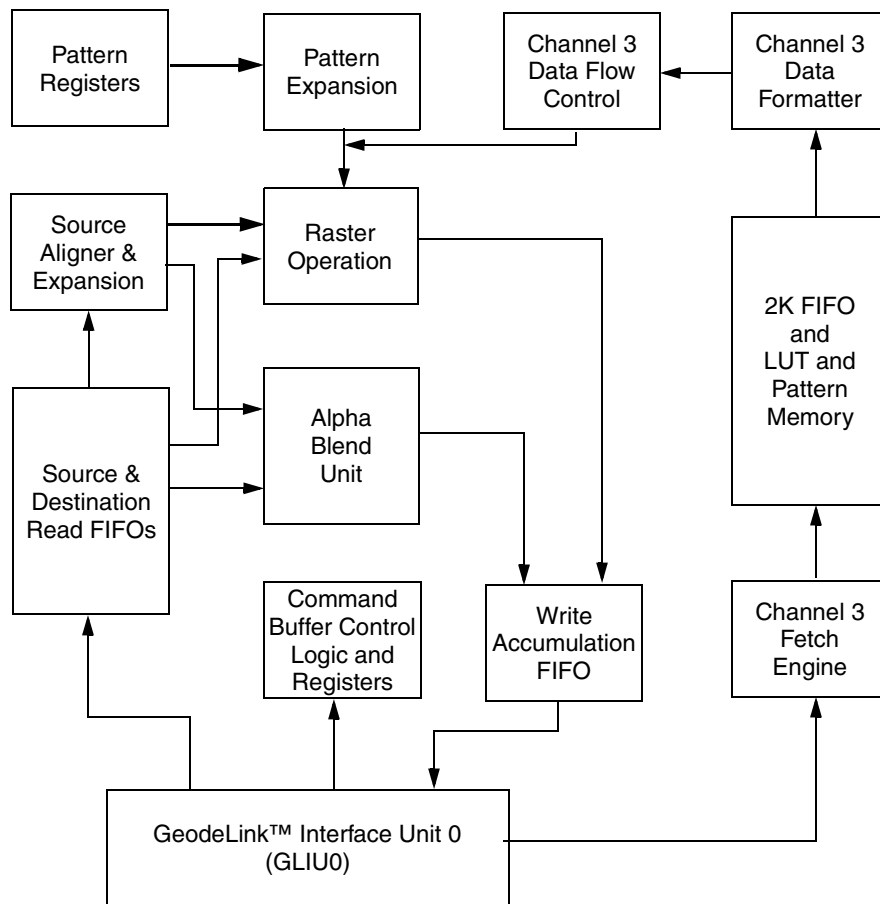


Figure 6-10. Graphics Processor Block Diagram

**Table 6-7. Graphics Processor Feature Comparison**

Feature	AMD Geode™ GX Processor	AMD Geode™ LX Processor
Color Depth	8, 16, 32-bpp	8, 16, 32-bpp (A) RGB 4 and 8-bit indexed
ROPs	256 (src, dest, pattern)	256 (2-src, dest and pattern)
BLT Buffers	FIFOs in Graphics Processor	FIFOs in Graphics Processor
BLT Splitting	Managed by hardware	Managed by hardware
Video Synchronized BLT/Vector	Throttle by VBLANK	Throttle by VBLANK
Bresenham Lines	Yes	Yes
Patterned (stippled) Lines	No	Yes
Screen to Screen BLT	Yes	Yes
Screen to Screen BLT with mono expansion	Yes	Yes
Memory to Screen BLT	Yes (through CPU writes)	Yes (throttled rep movs writes)
Accelerated Text	No	No
Pattern Size (Mono)	8x8 pixels	8x8 pixels
Pattern Size (Color)	8x1 (32 pixels)	8x8 pixels
	8x2 (16 pixels)	
	8x4 (8 pixels)	
Monochrome Pattern	Yes	Yes (with inversion)
Dithered Pattern (4 color)	No	No
Color Pattern	8, 16, 32-bpp	8, 16, 32-bpp
Transparent Pattern	Monochrome	Monochrome
Solid Fill	Yes	Yes
Pattern Fill	Yes	Yes
Transparent Source	Monochrome	Monochrome
Color Key Source Transparency	Y with mask	Y with mask
Variable Source Stride	Yes	Yes
Variable Destination Stride	Yes	Yes
Destination Write Bursting	Yes	Yes
Selectable BLT Direction	Vertical and Horizontal	Vertical and Horizontal
Alpha BLT	Yes (constant $\alpha$ or $\alpha/\text{pix}$ )	Yes (constant $\alpha$ , $\alpha/\text{pix}$ , or sep. $\alpha$ channel)
VGA Support	Decodes VGA Register	Decodes VGA Register
Pipeline Depth	2 ops	Unlimited
Accelerated Rotation BLT	No	8, 16, 32-bpp
Color Depth Conversion	No	5:6:5, 1:5:5:5, 4:4:4:4, 8:8:8:8

### 6.3.1 Command Buffer

The AMD Geode LX processor supports a command buffer interface in addition to the normal two-deep pipelined register interface. It is advised that software use either the command buffer interface or the register interface. It is possible to use both, however, all pending operations should be allowed to complete before making the switch. The command buffer interface is controlled through four registers that specify the starting address of the command buffer, the ending address of the command buffer, the current write pointer and the current read pointer. The base address (top 12 bits) of the command buffer is specified in the GLD\_MSR\_CONFIG (MSR A0002001h). During initialization, a block of memory is allocated to be the command buffer space. This block must be entirely contained within a non-cacheable 16 MB region of physical memory. The Geode LX processor will not issue coherent transactions for the command buffer or any other memory operations. The starting address should be written to GP\_CMD\_TOP and the ending address should be written to GP\_CMD\_BOT (GP Memory Offset 50h and 54h respectively). The starting address should also be written to GP\_CMD\_READ (GP Memory Offset 58h). Writing to GP\_CMD\_READ automatically updates GP\_CMD\_WRITE (GP Memory Offset 5Ch). From this point, software can ini-

tiate an action in the processor by writing a command buffer structure into memory at the write address (GP\_CMD\_WRITE), then updating the write address to point to the next available space in the command buffer, either the next contiguous DWORD address, or the buffer starting address (GP\_CMD\_TOP) if the wrap bit is set in the command buffer control word. Command buffers are allowed to wrap around the end of the command buffer space (i.e., whenever the end of the space is reached, the hardware will continue fetching at the beginning of the space creating a circular buffer). However, software may force a wrap before the end of the buffer space is reached by setting the wrap bit in the control word, which causes the hardware to reset its read pointer to the beginning of the buffer space when the current command buffer is complete.

Do not attempt to perform a BLT that expects host source data for both the old source channel and channel 3 unless one of the channels is receiving its host source data through the command buffer, and the other is receiving it directly from the processor. If this rule is violated, the GP and/or the entire system may hang.

The structure of a BLT command buffer is as follows:

**Table 6-8. BLT Command Buffer Structure**

31	30	29	28	27	26	25	24	23	22	21	20	19	18	17	16	15	14	13	12	11	10	9	8	7	6	5	4	3	2	1	0
W	0	0	S	RSVD												Write Enables															
GP_RASTER_MODE Data																															
GP_DST_OFFSET Data																															
GP_SRC_OFFSET Data																															
GP_STRIDE Data																															
GP_WID_HEIGHT Data																															
GP_SRC_COLOR_FG Data																															
GP_SRC_COLOR_BG Data																															
GP_PAT_COLOR_0 Data																															
GP_PAT_COLOR_1 Data																															
GP_PAT_DATA_0 Data																															
GP_PAT_DATA_1 Data																															
GP_CH3_OFFSET Data																															
GP_CH3_MODE_STR Data																															
GP_CH3_WIDHI Data																															
GP_BASE_OFFSET Data																															
GP_BLT_MODE Data																															
DTYPE				RSVD												DCOUNT															
Optional Data Word 0																															
Optional Data Word 1																															
...																															
Optional Data Word n																															

**Table 6-9. Vector Command Buffer Structure**

31	30	29	28	27	26	25	24	23	22	21	20	19	18	17	16	15	14	13	12	11	10	9	8	7	6	5	4	3	2	1	0
W	0	1	S	RSVD													Write Enables														
GP_RASTER_MODE Data																															
GP_DST_OFFSET Data																															
GP_VEC_ERR Data																															
GP_STRIDE Data																															
GP_VEC_LEN Data																															
GP_SRC_COLOR_FG Data																															
GP_PAT_COLOR_0 Data																															
GP_PAT_COLOR_1 Data																															
GP_PAT_DATA_0 Data																															
GP_PAT_DATA_1 Data																															
GP_CH3_MODE_STR Data																															
GP_BASE_OFFSET Data																															
GP_VECTOR_MODE Data																															

**Table 6-10. LUT (Lookup Table) Load Command Buffer Structure**

31	30	29	28	27	26	25	24	23	22	21	20	19	18	17	16	15	14	13	12	11	10	9	8	7	6	5	4	3	2	1	0
W	1	0	S	RSVD																							WE				
GP_LUT_INDEX Data																															
DTYPE				RSVD													DCOUNT														
Optional Data Word 0																															
Optional Data Word 1																															
...																															
Optional Data Word n																															

**Table 6-11. Data Only Command Buffer Structure**

31	30	29	28	27	26	25	24	23	22	21	20	19	18	17	16	15	14	13	12	11	10	9	8	7	6	5	4	3	2	1	0
W	1	1	0	RSVD																							1				
DTYPE				RSVD													DCOUNT														
Optional Data Word 0																															
Optional Data Word 1																															
...																															
Optional Data Word n																															



Where:

**Table 6-12. Bit Descriptions**

Name	Description
WE	<b>Write Enable.</b> One bit for each of the required DWORDs which follow in the command buffer. A set bit indicates that the field is valid and should be updated in the GP. A clear bit indicates the field should be skipped.
W	<b>Wrap Bit.</b> If set, then return to the top of command buffer space after executing this buffer.
S	<b>Stall Bit.</b> Execution of this command will be stalled until the GP's pipeline is empty.
DTYPE	<b>Data Type.</b> Type of data that follows: 000: Host source data to old host source channel 001: Host source data to new channel 3 010: Pattern data to GP_PAT_COLOR_2 - GP_PAT_COLOR5 (GP Memory Offset 20h-2Ch) 011: Write data for LUT/color pattern space 1xx: Reserved
DCOUNT	<b>DWORD Count.</b> Number of DWORDs of data that follow.

### 6.3.2 Channel 3

Channel 3 is an additional DMA channel (in addition to the first two channels: source and destination) that can fetch data from memory or receive it through host source writes. This channel has all of the data conversion features built in to perform rotational BLTs, color depth conversions, palletized color support (LUT lookups), 8x8 color pattern, and patterned vector support. The data coming out of this DMA pipeline can selectively be steered into the old source channel or the old pattern channel, whichever is more natural for a given ROP. Note that not all data coming out of this pipeline can be arbitrarily ROPed with other data (i.e., rotational BLT data can not be ROPed with any other channel, alpha data is expected to be used as input to the alpha unit). The behavior of channel 3 is controlled through GP\_CH3\_MODE\_STR (GP Memory Offset 64h). Channel 3 is also set up to be mostly independent from the other two channels, so it calculates its own addresses and pixel counters based on the GP\_CH3\_OFFSET and GP\_CH3\_WIDHI (GP Memory Offset 60h and 68h respectively). It is possible to set up this channel with a different width and height than the destination (i.e., a rotation BLT will have width and height swapped from the destination). As long as the number of pixels to be fetched is the same as the output, there should be no problem. If this channel has too few pixels to complete the BLT and is not in host source mode, the BLT will terminate when this channel has fetched all of the requested data, and the underflow bit will be set in GP\_BLT\_STATUS (GP Memory Offset 44h). If this channel has pixels left when the BLT is complete, the extra pixels are discarded and the overflow bit is set in GP\_BLT\_STATUS.

Channel 3 has the ability to begin prefetching data for a pending BLT before the active BLT has completed. The PE bit in the GP\_CH3\_MODE\_STR register (GP Memory Offset 64h[19]) can be set to allow prefetching for that BLT. Prefetching can safely be set for any BLT that does not require write data from the previous BLT as read data on channel 3. The GP does no hazard checking to verify the safety of the prefetch. This feature will incrementally improve performance as it allows the GP to make use of bus bandwidth that would otherwise have gone unused. Prefetching has the lowest bus priority and is only done opportunistically.

The X and Y bits (bits 29 and 28) in the GP\_CH3\_MODE\_STR register do not need to be programmed the same as the bits in the GP\_BLT\_MODE register (GP Memory Offset 40h). If they are the same, the result is a source copy. If both bits are programmed opposite from the GP\_BLT\_MODE register, then the result is a 180° rotation. If only one bit is opposite, the result is a flip in that direction.

When the current operation is a vector, channel 3 can generate byte enables to stylize the vector based upon the programmed pattern. Channel 3 cannot be used to generate any pixel data while rendering vectors.

### 6.3.2.1 Rotating BLTs

This feature of the GP allows bitmaps to be rotated 90°, 180° or 270°. The 90° and 270° modes work by reading vertical strips of the source bitmap that are one cache line (32 bytes) wide starting at either the top right or bottom left corner of the bitmap. The output is written as tiles that are one cache line wide by either 8, 16 or 32 pixels tall, depending on the color depth of the input data stream. Because the data is not written out in scan line order, none of the other channels can be correctly ROPed with the data, so this operation should be treated as a source copy. Also, because the entire buffer memory will be used for the fetched data, the input data stream may not be indexed color (it may be declared as 8-bpp, but it will not be converted through LUT lookups. This may be done on a second pass after the rotation).

To program a rotation BLT of 90° clockwise, the rotation bit should be on in the GP\_CH3\_MODE\_STR register (GP Memory Offset 64h[23]), the X and Y bits for channel 3 should be clear and set respectively, the X and Y in the GP\_BLT\_MODE register (GP Memory Offset 40h[9:8]) should both be clear, GP\_CH3\_OFFSET (GP Memory Offset 60h) should point to the bottom left corner of the source and GP\_DST\_OFFSET (GP Memory Offset 00h) should point to the top left corner of the destination.

To program a rotation BLT of 270° clockwise, the rotation bit should be on in the GP\_CH3\_MODE\_STR register, the X and Y bits for channel 3 should be set and clear respectively, the X and Y in the GP\_BLT\_MODE register should both be clear, GP\_CH3\_OFFSET should point to the top right corner of the source and GP\_DEST\_OFFSET should point to the top left corner of the destination.

To program a rotation BLT of 180° clockwise, the rotation bit should be off in the GP\_CH3\_MODE\_STR register, the X and Y bits for channel 3 should be opposite their counterparts in the GP\_BLT\_MODE register, and GP\_CH3\_OFFSET should point to the opposite corner from GP\_DEST\_OFFSET.

For all rotations, it is required that both the source stride and the destination stride be aligned to a cache line boundary (i.e., bottom 5 bits of stride are all 0s). Do not attempt to rotate host source data. The fill algorithm would be too complex and the likelihood of causing a FIFO underrun and hanging the GP is too high.

Note that for rotation BLTs, the PL bit in the GP\_CH3\_MODE\_STR register (GP Memory Offset 64h[20]) may not be set. The entire buffer is needed for the rotation so the LUT and pattern data may not be retained.

### 6.3.2.2 Rotating Video

The GP is primarily an RGB engine that does not natively understand YUV data. However, it is possible to perform video rotations using the GP hardware assuming the data is formatted correctly. If the data is in 4:2:0 format with the Y data separated from the UV data, the rotation can be performed by passing each channel of the image separately through the GP and setting the color depth appropriately. For the Y data, the color depth should be set to 8-bpp 3:3:2. The same is true for the U and V data if they are in separate channels. If the U and V data are combined in one buffer then the color depth should be set to 16-bpp 5:6:5. Similarly, 4:4:4 format data can also be supported if each channel is stored in its own buffer.

### 6.3.2.3 Color Depth Conversion

If the BPP/FMT bits in the GP\_CH3\_MODE\_STR register (GP Memory Offset 64h[27:24]) are set different than the BPP/FMT bits in the GP\_RASTER\_MODE register (GP Memory Offset 38h[31:28]), then the incoming data is converted to match the output format. If the BGR bit (GP Memory Offset 64h[22]) is set, then the red and blue channels of the data will be swapped prior to the depth conversion (if any).

A 24-bpp source format is supported on channel 3 allowing packed RGB pixels to be unpacked as they are written into the frame buffer. For this format, the channel 3 width is specified in DWORDs, not pixels. As a result, the channel 3 offset for 24-bpp data must therefore be aligned to a DWORD boundary. BGR conversion is not possible in this format since this operation is done before the depth conversion. 24-bpp images may not be rotated, they would need to be converted into another format first.

### 6.3.2.4 Palletized Color Support

If the Preserve LUT Data bit is set in the GP\_CH3\_MODE\_STR register (GP Memory Offset 64h[20]) then 1K of the 2K buffer space will be allocated to be a LUT. As long as this bit remains set, the LUT data is preserved as written. Setting this bit has the impact of slightly lowering performance since it limits the prefetch ability of the GP, or its ability to receive massive amounts of host source data. This is unlikely to be a significant issue, but if the LUT is not needed for future BLTs, then clearing this bit is recommended. It is required to be cleared during rotations since the entire 2K buffer space is needed.

If the BPP/FMT bits in the GP\_CH3\_MOD\_STR register (GP Memory Offset 64h[27:24]) indicate that the incoming data is either 4 or 8-bpp indexed mode, then the LUT will be used to convert the data into 16 or 32-bpp mode as specified in the GP\_RASTER\_MODE register's BPP/FMT field (GP Memory Offset 38h[31:28]). The LUT should be loaded prior to initiating such a BLT by writing an address to the GP\_LUT\_INDEX register (GP Memory Offset 70h) followed by one or more DWORD writes to the GP\_LUT\_DATA register (GP Memory Offset 74h) that will be loaded into the LUT starting at that address. The

address automatically increments with every write. Addresses 00h-FFh are used for 8-bpp indexed pixels and addresses 00h-0Fh are used for 4-bpp indexed pixels. The result of a lookup is always a DWORD. If the output format is only 16-bpp, then only the data in the two least significant bytes is used.

For 4-bpp incoming data, two pixels are packed within a byte such that bits[7:4] contain the leftmost pixel and bits[3:0] contain the rightmost pixel. The pixel ordering for 4-bit pixels is shown in Table 6-13.

For host source data, the starting offset into the first DWORD is taken from GP\_CH3\_OFFSET[1:0] (and GP\_CH3\_OFFSET[28] if the data is 4-bpp). For data being fetched from memory, GP\_CH3\_OFFSET[23:0] specifies the starting byte and GP\_CH3\_OFFSET[28] specifies the nibble within the byte for 4-bpp mode.

Note that, regardless of the output pixel depth, palletized color has a throughput of no more than one clock per pixel. The LUTs share memory with the incoming data FIFO, so the datapath first pops the incoming indexed pixels out of the FIFO (8 or 16 at a time), then performs the LUT lookup, one pixel per clock, for the next 8 or 16 clocks, then must pop more data out of the FIFO.

**Table 6-13. Pixel Ordering for 4-Bit Pixels**

31	30	29	28	27	26	25	24	23	22	21	20	19	18	17	16	15	14	13	12	11	10	9	8	7	6	5	4	3	2	1	0
Pixel 6				Pixel 7				Pixel 4				Pixel 5				Pixel 2				Pixel 3				Pixel 0				Pixel 1			

**6.3.2.5 Anti-Aliased Text Support**

Channel 3 can be setup to fetch 4-bpp alpha channel data that can be combined with either 16 or 32-bpp color or monochrome source data using the alpha unit in the GP. The depth and type in the GP\_CH3\_MODE\_STR register should be setup to indicate 4-bpp alpha and the AS bits in the GP\_RASTER\_MODE register (GP Memory Offset 38h[19:17]) should be set to 110 to select the alpha from channel 3.

**6.3.2.6 8x8 Color Pattern**

Channel 3 can also be configured to source full color patterns into the GP. The pattern data is stored in the 2K buffer using writes to the GP\_LUT\_INDEX and GP\_LUT\_DATA registers (GP Memory Offset 70h and 74h, respectively) as done for loading the LUT. Addresses 100h-10Fh are used for 8-bpp patterns, 100h-11Fh are used for 16-bpp patterns and 100h-13Fh are used for 32-bpp patterns. Note that this data will not be persistent in the buffer. If channel 3 is later used in non-pattern mode, then the pattern data will no longer be present in the buffer. Therefore it is usually necessary to reload the pattern data before any BLT requiring 8x8 color pattern support. The depth of the pattern is determined by the BPP/FMT bits (GP Memory Offset 64h[27:24]) of the GP\_CH3\_MODE\_STR register (4-bpp is not allowed in

pattern mode). The output of the pattern hardware is converted to the depth specified in the BPP/FMT GP bits (Memory Offset 38h[31:28]) of the GP\_RASTER\_MODE register if the two depths do not match.

**6.3.2.7 Patterned Vectors**

When pattern mode is enabled during a vector operation, channel 3 generates a patterned (stippled) vector. This is a linear monochrome pattern that is stored in the LUT at locations 100h and 101h. The first DWORD (100h) contains the pattern, which is a string of four to 32 bits starting at bit 0. The second DWORD is used to indicate the length of the pattern and is a string of four to 32 ones starting at bit 0. Tables 6-14 and 6-15 show an example vector pattern and length. The result of this vector pattern/length would be a 14-bit long pattern that, when repeated, looks Figure 6-11.

The dark pixels are rendered using the selected ROP, while the light pixels are transparent. The ROP may contain any combination of source, destination and pattern. If pattern is enabled in the ROP, it comes from the old (non-channel 3) pattern hardware. Note that a vector pattern must be at least four pixels long. For shorter patterns (i.e., two on, one off), repeat the pattern in the pattern registers until it is at least four pixels long.

**Table 6-14. Example Vector Pattern**

31	30	29	28	27	26	25	24	23	22	21	20	19	18	17	16	15	14	13	12	11	10	9	8	7	6	5	4	3	2	1	0
0	0	0	0	0	0	0	0	0	0	0	0	0	0	0	0	0	0	0	0	1	1	0	0	1	1	0	0	1	1	1	1

**Table 6-15. Example Vector Length**

31	30	29	28	27	26	25	24	23	22	21	20	19	18	17	16	15	14	13	12	11	10	9	8	7	6	5	4	3	2	1	0
0	0	0	0	0	0	0	0	0	0	0	0	0	0	0	0	0	0	1	1	1	1	1	1	1	1	1	1	1	1	1	



**Figure 6-11. 14-Bit Repeated Pattern**

### 6.3.2.8 Channel 3 Host Source

Channel 3 also supports host source data writes. When the HS bit is set in the GP\_CH3\_MODE\_STR register (GP Memory Offset 64h[18]), the channel 3 fetch engine is disabled and the FIFOs are filled via register writes to the GP\_CH3\_HSRC register (GP Memory Offset 6Ch) or its aliased space. If the PL bit in the GP\_CH3\_MODE\_STR register (GP Memory Offset 64h[20]) is not set then the GP can accept 2 KB of data through host source writes before its buffers are full. However, since monochrome is not supported on this channel, the output flow rate of data closely matches the input flow (worst case is 8:1 if output is 32-bpp and input is 4-bpp) so it is unlikely that the GP will ever fill up. If it does fill its 2K buffer, then writes from the GLIU will be disabled until there is space available to store it. Software should not have to poll this interface to keep from overrunning the FIFOs. It should be noted that, while it is possible to program the GP to accept host source data on both the source channel and channel 3, this should not be done unless one of the channels is filled through the command buffer and the other through direct writes to the register. If this is the case, it is recommended that the source channel be filled through the command buffer and channel 3 be filled through register writes, since this will eliminate polling and provide higher performance. It will probably require less memory as well since the data into the source channel will likely be monochrome and fit into a smaller command buffer.

### 6.3.2.9 Channel 3 Hints

Software should try to setup the BLTs to use channel 3 whenever possible. This channel is designed to have the highest performance, since it is capable of prefetching great quantities of data even before a BLT actually starts. This channel must be used when performing rotating BLTs, color depth conversions, palletized color, or 8x8 color patterns. This channel can carry source data, destination data, per-pixel alpha data, or pattern data. This channel cannot be used for monochrome data, and cannot be used for source or destination data if it must be ROPed with 8x8 pattern data. If the pattern does not need to be 8x8, then the old pattern hardware should be used as this will free up channel 3 to be used for higher performance memory fetches and host source data.

The source channel has the next highest performance, and should be used if two channels are necessary or if the data cannot be carried on channel 3. This channel can be used to fetch destination data, and the performance will be higher than using the destination channel.

The destination channel should only be used to carry destination data when it cannot be carried on either of the other two channels. This should only be the case when the ROP calls for source, destination and pattern, when the operation is a vector, or when alpha requires an A and B channel. In all other cases, performance will be higher if destination is fetched on either the source channel or channel 3.

### 6.3.3 BLT Operation

To perform a BLT, several registers must first be configured by the driver to specify the operation of the BLT engine. These registers specify the source and destination offsets into the frame buffer, the width and height of the BLT rectangle, and the raster mode or alpha blend mode. In addition, any source colors, pattern colors, and pattern data should be loaded before initiating a BLT.

BLTs are initiated by writing to the GP\_BLT\_MODE register (GP Memory Offset 40h). This register indicates the need for source and destination data, and defines the type of source data, and the direction in which the BLT should proceed. Color BLTs may be performed from left to right or right to left, top to bottom or bottom to top. This allows data to be transferred within the screen space without corrupting the areas from where the data is being copied. When monochrome source is used, however, the BLT must be performed from left to right.

Instead of BLT buffers (L1 cache), Source Read, Destination Read, and Destination Write FIFOs are used to temporarily store the data that flows through the Graphics Processor. Overflowing the FIFOs is not possible since the transfer is managed by the hardware anywhere within the 16 MB frame buffer memory region. At the start of a BLT, two cache lines of destination data and up to four cache lines of source data are fetched (if needed). Source data is fetched in groups of four cache lines, when possible.

Source data may either be read from within the frame buffer memory space or received from the CPU via writes to the GP\_HST\_SRC register (GP Memory Offset 48h). In either case, the data may be monochrome or color, as specified in the GP\_BLT\_MODE register (GP Memory Offset 40h). If no source color is specified, the contents of the GP\_SRC\_COLOR\_FG register (GP Memory Offset 10h) is used as the default. For a solid fill, neither source, destination, nor pattern are required and the resulting output pixel is derived from the contents of the GP\_PAT\_COLOR\_0 register (GP Memory Offset 18h). The destination of the BLT is always within the frame buffer memory region and is always the specified color depth, never monochrome.

A bit is provided in the mode registers to allow BLTs and vectors to be throttled. When this bit is set for a particular operation, that operation does not begin executing until the next time the video timing enters vertical blank (VBLANK). This function can be used to improve 2D quality by minimizing tearing that occurs when writing to the frame buffer while the image is being drawn to the screen.

### 6.3.4 Vector Operation

Generating a vector requires a similar setup to a BLT. Registers must be written to specify the X and Y offsets of the starting position of the vector within the frame buffer, the vector length, and the three error terms required by the Bresenham algorithm. In addition, any pattern colors and pattern data should be loaded before initiating the vector. Source data is not fetched when rendering vectors. Instead, the contents of the GP\_SRC\_COLOR\_FG register (GP Memory Offset 10h) are used as the constant color for the vector.

Vectors are initiated by writing to the GP\_VECTOR\_MODE (GP Memory Offset 3Ch) register. This register also indicates the need for destination data, and defines the major axis (X or Y) and the major and minor directions (incrementing or decrementing) of the vector.

As in the BLT operation, vectors can be throttled by video timing to prevent tearing. Setting the TH bit in the GP\_VECTOR\_MODE register (GP Memory Offset 3Ch[4]) causes the Graphics Processor to wait until the next time that video timing enters VBLANK before beginning to render the vector.

### 6.3.5 Pipelined Operation

Most of the graphics registers are pipelined. When the registers are programmed and the operation begins, the contents of the registers are moved from slave registers to master registers, leaving the slave registers available for another operation. A second BLT or vector operation can then be loaded into the slave registers while the first operation is rendered. If a second BLT is pending in the slave registers, additional write operations to the graphics registers will corrupt the register values of the pending BLT. Software must prevent this from happening by checking the Primitive Pending bit in the GP\_BLT\_STATUS register (GP Memory Offset 44h[2]).

The GP\_PAT\_COLOR\_2 through GP\_PAT\_COLOR\_5 (GP Memory Offset 20h-2Ch) registers are not pipelined. If they are used in a new graphics operation, they should not be written when the Primitive Busy bit (GP Memory Offset 44h[0]) is set and the Primitive Pending bit is not set in the GP\_BLT\_STATUS register, and the active operation is using these registers. Writing to these registers when a BLT is active corrupts that operation.

### 6.3.6 Pattern Generation

The Graphics Processor contains hardware support for 8x8 monochrome patterns (expanded to two colors), and color patterns. Color patterns can be 8x4 in 8-bpp mode, 8x2 in 16-bpp mode, and 8x1 in 32-bpp mode. Pattern alignment is based on the destination X and Y LSBs of the pixel being drawn, so software can perform pattern justifications by adjusting these two parameters. For solid fill primitives, the pattern hardware is disabled and the pattern color is always sourced from the GP\_PAT\_COLOR\_0 register (GP Memory Offset 18h).

#### 6.3.6.1 Monochrome Patterns

Monochrome patterns are enabled by selecting monochrome pattern mode in the GP\_RASTER\_MODE register (GP Memory Offset 38h). Pixels that correspond to a clear bit in the pattern are rendered using the color specified in the GP\_PAT\_COLOR\_0 (GP Memory Offset 18h) register, and pixels that correspond to a set bit in the pattern are rendered using the color specified in the GP\_PAT\_COLOR\_1 register (GP Memory Offset 1Ch).

If the pattern transparency bit is set in the GP\_RASTER\_MODE register (GP Memory Offset 38h), those pixels corresponding to a clear bit in the pattern data are not drawn, leaving the frame buffer pixels at these locations untouched.

The pattern itself is loaded into the GP\_PAT\_DATA\_0 and GP\_PAT\_DATA\_1 registers, with row 0 loaded into GP\_PAT\_DATA\_0 (GP Memory Offset 30h[7:0] (bit 7 being the left-most pixel on the screen)), and row 7 loaded into GP\_PAT\_DATA\_1 (GP Memory Offset 34h[31:24], see Table 6-16).

### 6.3.6.2 Color Patterns

Color patterns are enabled by selecting the color pattern mode in the GP\_RASTER\_MODE register (GP Memory Offset 38h). In this mode, both of the GP\_PAT\_DATA registers and all six of the GP\_PAT\_COLOR registers are combined to provide a total of 256 bits of pattern. The number of lines that the pattern can hold is dependent upon the number of bits per pixel. When performing a BLT that needs a deeper color pattern than is supported (such as 8x8), software is responsible for breaking the BLT into blocks such that the height of each block does not exceed the depth of the pattern. After each block is completed, software must update the pattern registers before continuing with the next block of the BLT. As a result of having a programmable stride value, it is now possible to reduce the number of passes required to perform a BLT requiring a color pattern, by multiplying the stride value by the number of passes that are required to perform the BLT. For example, in 8-bpp mode, where only an 8x4 pattern fits, the stride value could be doubled such that all of the even lines

would be BLT'd during the first pass, and all of the odd lines during the second pass. The pattern registers should be programmed with the even lines on the first pass and the odd lines on the second pass, and the Y Offset value should be the start of the bitmap on the first pass and the start of the second line of the bitmap on the second pass. The algorithm can be extended to handle 8x2 and 8x1 patterns in four and eight passes. This only works, however, when the source and destination are non-overlapping. When performing an overlapping BLT, it is necessary to fall back to breaking the BLT into four, two, or one consecutive lines and reprogramming the pattern registers between each block.

Pattern transparency is not supported in color pattern mode.

In 8-bpp mode, there is a total of four lines of pattern, each line with eight pixels as illustrated in Table 6-17 on page 248.

**Table 6-16. Example of Monochrome Pattern**

	Bit 7	Bit 6	Bit 5	Bit 4	Bit 3	Bit 2	Bit 1	Bit 0
GP_PAT_DATA_0[7:0] - 14h								
GP_PAT_DATA_0[15:8] - 22h								
GP_PAT_DATA_0[23:16] - 41h								
GP_PAT_DATA_0[31:24] - 80h								
GP_PAT_DATA_1[7:0] - 41h								
GP_PAT_DATA_1[15:8] - 22h								
GP_PAT_DATA_1[23:16] - 14h								
GP_PAT_DATA_1[31:24] - 08h								

**Table 6-17. Example of 8-Bit Color Pattern (3:3:2 Format)**

	Byte 7	Byte 6	Byte 5	Byte 4	Byte 3	Byte 2	Byte 1	Byte 0
GP_PAT_DATA_1 (02024002h) GP_PAT_DATA_0 (40024002h)	02	02	40	02	40	02	40	02
GP_PAT_COLOR_1 (0240E340h) GP_PAT_COLOR_0 (0240E340h)	02	40	E3	403	02	40	E3	40
GP_PAT_COLOR_3 (40E300E3h) GP_PAT_COLOR_2 (40E300E3h)	40	E3	00	E3	40	E3	00	E3
GP_PAT_COLOR_5 (0240E340h) GP_PAT_COLOR_4 (0240E340h)	02	40	E3	40	02	40	E3	40

In 16-bpp mode, there is a total of two lines of pattern, each line with eight pixels as illustrated in Table 6-18. In 32-bpp mode, there is only one line of pattern with eight pixels. The ordering of the registers in the line from left to right is as follows:

- 1) GP\_PAT\_COLOR\_5
- 2) GP\_PAT\_COLOR\_4
- 3) GP\_PAT\_COLOR\_3
- 4) GP\_PAT\_COLOR\_2
- 5) GP\_PAT\_COLOR\_1
- 6) GP\_PAT\_COLOR\_0
- 7) GP\_PAT\_DATA\_1
- 8) GP\_PAT\_DATA\_0.

**Table 6-18. Example of 16-Bit Color Pattern (5:6:5 Format)**

	Byte 15:14	Byte 13:12	Byte 11:10	Byte 9:8	Byte 7:6	Byte 5:4	Byte 3:2	Byte 1:0
GP_PAT_COLOR_1 (00100010h) GP_PAT_COLOR_0 (40000010h)	0010	0010	4000	0010	4000	0010	4000	0010
GP_PAT_DATA_1 (02028002h) GP_PAT_DATA_0 (80028002h)								
GP_PAT_COLOR_5 (00104000h) GP_PAT_COLOR_4 (F81F4000h)	0010	4000	F81F	4000	0010	4000	F81F	4000
GP_PAT_COLOR_3 (0280E380h) GP_PAT_COLOR_2 (0280E380h)								



### 6.3.7 8x8 Color Patterns

The new channel 3 hardware provides the capability of performing BLTs with 64 pixel color patterns at all color depths. To setup this mode, software first loads the pattern data into the LUT beginning at address 100h. The least significant byte of this first DWORD contains the upper left most pixel of the pattern. For 8-bpp mode, the most significant byte of the next DWORD contains the upper right most pixel of the pattern. In 16-bpp mode, the upper right most pixel is contained in the most significant bytes of the fourth DWORD, and for 32-bpp mode, the eighth DWORD contains the upper right most pixel. The next line of the pattern begins at the DWORD that follows the last pixel of the previous line, such that the pattern is packed into the space required to hold it. So for 8-bpp mode, the top left pixel is in the least significant byte of the DWORD at address 100h in the LUT, the top right pixel is in the most significant byte of the DWORD at address 101. The bottom left pixel is in the least significant byte of the DWORD at address 10Eh and the bottom right pixel is in the most significant byte of the DWORD at address 10Fh.

To enable this mode, the EN and PM bits should be set in the GP\_CH3\_MODE\_STR register (GP Memory Offset 64h[31, 21]): EN, PM. The PS, HS, RO, X, and Y bits should not be set in the GP\_CH3\_MODE\_STR register. The BPP/FMT bits in the GP\_CH3\_MODE\_STR register (bits [27:24]) indicate the color depth of the pattern data. If this does not match the BPP/FMT bits in the

GP\_RASTER\_MODE register (GP Memory Offset 38h[31:28]), then the pattern is translated to the depth specified by the GP\_RASTER\_MODE register.

### 6.3.8 Source Data

When called for by the raster operation or alpha blender, software should set the source required bits in the GP\_BLT\_MODE register (GP Memory Offset 40h) so that source data is fetched from the frame buffer memory or can be written by the host to the GP\_HST\_SRC register (GP Memory Offset 48h). Regardless of its origination, source data can either be monochrome (expanded to two colors) or color. The hardware aligns the incoming source data to the appropriate pixel lanes for writing to the destination. Source data is only used when in BLT mode. In vector mode, GP\_SRC\_COLOR\_FG (GP Memory Offset 10h) is forced onto the source channel.

#### 6.3.8.1 Source Data Formats

The Graphics Processor expects to see the left-most pixels on the screen in the least significant bytes of the DWORD and the right-most pixels in the most significant bytes. For monochrome data within a byte, the left-most pixels are in the most significant bits of the byte, and the right-most pixels are in the least significant bits. These formats are shown more clearly in Table 6-19, Table 6-20, Table 6-21, and Table 6-22.

**Table 6-19. 32-bpp 8:8:8 Color Data Format**

Byte 3	Byte 2	Byte 1	Byte 0
Alpha/Unused	Red	Green	Blue

**Table 6-20. 16-bpp Color Data Format**

Format	Byte 3			Byte 2			Byte 1			Byte 0			
	Right Pixel Data						Left Pixel Data						
5:6:5	Red		Green			Blue			Red		Green		Blue
4:4:4:4	Alpha	Red	Green	Blue	Alpha	Red	Green	Blue	Alpha	Red	Green	Blue	
1:5:5:5	A	Red	Green	Blue	A	Red	Green	Blue	A	Red	Green	Blue	

**Table 6-21. 8-bpp 3:3:2 Color Data Format**

Byte 3	Byte 2	Byte 1	Byte 0
Right Pixel Data (3:3:2)	Pixel 2 Data	Pixel 1 Data	Left Pixel Data (3:3:2)

**Table 6-22. Monochrome Data Format**

Byte 3								Byte 2								Byte 1								Byte 0							
0	1	2	3	4	5	6	7	0	1	2	3	4	5	6	7	0	1	2	3	4	5	6	7	0	1	2	3	4	5	6	7
24	25	26	27	28	29	30	31	16	17	18	19	20	21	22	23	8	9	10	11	12	13	14	15	0	1	2	3	4	5	6	7
Right Most Pixel																Left Most Pixel															

**6.3.8.2 Host Source**

For source data that is not already in the frame buffer region of memory, software can use the GP\_HST\_SRC register (GP Memory Offset 48h) for loading the data into the Graphics Processor. This is achieved by selecting host source as the origination of the source data when setting up the BLT. After writing to the GP\_BLT\_MODE register (GP Memory Offset 40h) to initiate the BLT, software must first check to make sure that the host source BLT is active by checking that the BP bit of the GP\_BLT\_STATUS register (GP Memory Offset 44h[0]) is not set before proceeding with successive writes to the GP\_HST\_SRC register (GP Memory Offset 48h). Enough writes must be generated to complete the requested BLT operation. Any extra writes, or writes when host source data is not required, are ignored, not saved, and will not be used for the next BLT. Writes to this register are buffered into the source FIFO to decouple the processor from the Graphics Processor. The source FIFO is currently two cache lines deep, allowing the processor to load up to 64 bytes of data. If more data is needed, the driver can then poll the SHE (Source FIFO Half Empty) bit of the GP\_BLT\_STATUS register (GP Memory Offset 44h[3]). When this bit is set, the source FIFO can accept at least one more cache line of data. Writ-

ing to the Graphics Processor while the Host Source FIFO is full causes the Graphics Processor to drop the writes, which means that the BLT is corrupt and most likely will not complete. Since there is not enough host source data left, the Graphics Processor hangs waiting for more source data.

The two LSBs of the source OFFSET are used to determine the starting byte of the host source data and the XLSBs are used in the case of monochrome source data to determine the starting bit. The starting pixel of the source data is aligned to the starting pixel of the destination data by the hardware. In monochrome byte-packed mode, the hardware begins BLTing at the specified pixel, and after WIDTH pixels have been transferred, skips the remaining bits in the byte plus the number specified in XLSBs, and begins the next line at that location. In unpacked monochrome mode or color mode, the hardware discards any data remaining in the DWORD after WIDTH pixels have been transferred and begins the next line at the byte specified by the two LSBs of the offset in the next DWORD received. Examples of these two modes are shown in Table 6-23 and Table 6-24, with OFFSET set to 0h, XLSBs set to 2h, and WIDTH set to 8h.

**Table 6-23. Example of Byte-Packed Monochrome Source Data**

Byte 3								Byte 2								Byte 1								Byte 0							
0	1	2	3	4	5	6	7	0	1	2	3	4	5	6	7	0	1	2	3	4	5	6	7	0	1	2	3	4	5	6	7
16	17									10	11	12	13	14	15	06	07									00	01	02	03	04	05
36	37									30	31	32	33	34	35	26	27									20	21	22	23	24	25
56	57									50	51	52	53	54	55	46	47									40	41	42	43	44	45
Skip specified by XLSBs																															
Trailing bits at end of line																															

**Table 6-24. Example of Unpacked Monochrome Source Data**

Byte 3								Byte 2								Byte 1								Byte 0							
0	1	2	3	4	5	6	7	0	1	2	3	4	5	6	7	0	1	2	3	4	5	6	7	0	1	2	3	4	5	6	7
																06	07									00	01	02	03	04	05
																16	17									10	11	12	13	14	15
																26	27									20	21	22	23	24	25
Skip specified by XLSBs																															
Trailing bits at end of line																															

### 6.3.8.3 Source Expansion

The Graphics Processor contains hardware support for color expansion of monochrome source data. Those pixels corresponding to a clear bit in the source data are rendered using the color specified in the GP\_SRC\_COLOR\_BG register (GP Memory Offset 14h), and the pixels that are set in the source data are rendered using the color specified in the GP\_SRC\_COLOR\_FG register (GP Memory Offset 10h).

### 6.3.8.4 Source Transparency

If the source transparency bit is set in the GP\_RASTER\_MODE register (GP Memory Offset 38h[11]), not all source pixels result in a write to the frame buffer.

In monochrome mode, source pixels that are clear are inhibited from writing to the frame buffer, so only foreground colored pixels are written.

In color mode, the source pixel is compared to the value stored in the GP\_SRC\_COLOR\_FG register (GP Memory Offset 10h). The resulting compare is masked by the value in the GP\_SRC\_COLOR\_BG register (GP Memory Offset 14h), allowing color keying on specific channels within a pixel. If all the bits that are not masked compare with their corresponding bits in the GP\_SRC\_COLOR\_FG register, then the pixel write is inhibited. For example, to make all blue pixels transparent in 8-bpp mode,

GP\_SRC\_COLOR\_FG is loaded with 03h (hardware expands this into four blue pixels) and GP\_SRC\_COLOR\_BG (GP Memory Offset 14h) is loaded with FFh (perform compare on all bits). To make all pixels transparent that have more than 50% in their alpha channel for 32-bpp data, load GP\_SRC\_COLOR\_FG with 80000000h and GP\_SRC\_COLOR\_BG with 80000000h.

### 6.3.9 Destination Data

When required by the raster operation or alpha blender, destination data is fetched from the frame buffer memory. This data is required to be in color at the depth specified (8, 16, or 32-bpp). Source or pattern transparent mode does not necessarily require destination data to be fetched, since transparent pixels are inhibited from being written to the frame buffer rather than re-written with the destination data. Transparency is never keyed off of destination data.

### 6.3.10 Raster Operations (ROP)

The GP\_RASTER\_MODE register (GP Memory Offset 38h) specifies how the pattern data, source data, and destination data are combined to produce the output from the Graphics Processor. The definition of the ROP value matches that of the Microsoft® API. This allows Microsoft Windows® display drivers to load the raster operation directly into hardware. See Table 6-25 and Table 6-26 for the definition of the ROP value.

**Table 6-25. GP\_RASTER\_MODE Bit Patterns**

Pattern (bit)	Source (bit)	Destination (bit)	Output (bit)
0	0	0	ROP[0]
0	0	1	ROP[1]
0	1	0	ROP[2]
0	1	1	ROP[3]
1	0	0	ROP[4]
1	0	1	ROP[5]
1	1	0	ROP[6]
1	1	1	ROP[7]

**Table 6-26. Common Raster Operations**

ROP	Description
F0h	Output = Pattern
CCh	Output = Source
5Ah	Output = Pattern xor destination
66h	Output = Source xor destination
55h	Output = ~Destination
33h	Output = ~Source

### 6.3.11 Image Compositing Using Alpha

Whereas the raster operation allows different streams of data to be logically combined, alpha channel composition allows two streams of data to be mathematically combined based on the contents of their alpha channel, which is an additional channel to the red, blue, and green data contained in the stream. The use of alpha channel composition allows the streams of data to be combined in more complex functions than that available from the raster operation.

For example, assume that image A, containing a blue triangle, is to be combined with image B, containing a red triangle. These images can be combined such that image A sits on top of image B or vice versa. The alpha values in these images reflect the percentage of a given pixel that is covered by the image. In image A, for instance, a pixel completely within the triangle has an alpha value of 1, while a pixel completely outside of the triangle has an alpha value of 0. A pixel on the edge of the triangle has a value between 0 and 1 depending on how much of it is covered by the triangle. When combining these images such that A appears over B, pixels within the blue triangle appear blue, pixels outside the blue triangle but within the red triangle appear red, and pixels entirely outside of both triangles are black. Pixels on the edge of either triangle have their color scaled by the percentage of the pixel that lies within the triangle.

When working with images using alpha channels, it is assumed that each pixel of the entire image is premultiplied by the alpha values at that pixel. This is assumed since every compositing operation on the data stream requires this multiplication. If an image has not been premultiplied, the Graphics Processor can perform this multiplication in a single pass prior to setting up the composition operation. By setting up the Graphics Processor to fetch destination data, this operation can be done in-place without requiring a temporary storage location to hold the multiplied image. Once the image is premultiplied, it can be manipulated through alpha composition without ever having to perform this multiplication step again.

Table 6-27 describes the various ways that the two images can be composited using the alpha blender. For some of these cases, a third alpha value, in addition to the image

stream data alphas is needed. This alpha,  $\alpha_R$ , is specified in the GP\_RASTER\_MODE register (GP Memory Offset 38h). The two channels specified, A and B, represent the two streams of image data being fetched by the Graphics Processor as source and destination data. Use the CS bit to select whether channel A gets source data or destination data. Channel B always gets the data not selected on channel A. Note that if the combination of OS and AS bits in the GP\_RASTER\_MODE register select data from one channel and  $\alpha$  from another, then both source and destination data are required to correctly perform the BLT. It is up to software to assure that the appropriate controls are set in the GP\_BLT\_MODE register (GP Memory Offset 40h) to fetch the required data. See Section 6.3.10 "Raster Operations (ROP)" on page 251 for details on how to program these functions.

Alpha blending is NOT supported for 8-bpp color depth. For 16 and 32-bpp, the alpha unit supports all of the formats. Note that the 0:5:6:5 format does not support an alpha channel with the data. When using 0:5:6:5, alpha must always be selected from the register or else it is the constant 1 (100%) and selecting  $\alpha_A$  or  $\alpha_B$  yields indeterminate results.


To perform the premultiply of a given data stream, use the "A" operation in Table 6-27, but set the alpha select to  $\alpha_A$  (AS = 00) instead of 1. In this case, the enable bits should be set so that the operation only applies to the RGB values (EN = 01).

The operation "A stop B" requires two passes through the alpha unit. The first pass creates an "A in B" image and the second pass uses this intermediate image and performs an "A over B" operation.

The operation "A xor B" requires three passes through the alpha unit. The first two perform "B held out by A" on each image independently, and the final pass adds the two images together using "A plus B."

The result of an alpha calculation is clamped at the maximum pixel value. Thus, if the result of  $A + (1-\alpha)B$  (the only calculation that could possibly overflow) does overflow in a given color channel, then the result for that channel is all 1s.

**Table 6-27. Alpha Blending Modes**

Operation	Diagram	$F_A$	$F_B$	Description	AS Bits	OS Bits
CLEAR		0	0	Resulting image is clear.		
A		1 ( $\alpha_A$ )	0	Display only one of the images (or multiply an image by its alpha).	011 (00)	00 (00)

**Table 6-27. Alpha Blending Modes (Continued)**

Operation	Diagram	$F_A$	$F_B$	Description	AS Bits	OS Bits
A over B		1	$1-\alpha_A$	Display image A on top of image B. Wherever image A is transparent, display image B.	000	10
A in B		$\alpha_B$	0	Use image B to mask image A. Wherever image B is non-transparent, display image A.	001	00
B held out by A		0	$1-\alpha_A$	Use image A to mask image B. Wherever image A is transparent, display image B.	000	01
A stop B		$\alpha_B$	$1-\alpha_A$	Use image B to mask image A. Display A if both images are non-transparent, otherwise display B.	001 000	00 10
A xor B		$1-\alpha_B$	$1-\alpha_A$	Display images only where they do not overlap.	001 000	01 10
darken A		$\alpha_R$	0	Multiply RGB channels of image A by specified value. (Use enables to apply to RGB.)	010	00
opaque A		$\alpha_R$	0	Multiply $\alpha$ channel of image A by a specified value. (Use enables to apply to alpha.)	010	00
fade A		$\alpha_R$	0	Multiply all channels of image A by a specified value.	010	00
fade A plus fade B		$\alpha_R$	$1-\alpha_R$	Blend images A and B using $\alpha_R$ to specify percentage of A and B in the resulting image.	010	11
A plus B		1	1	Add images A and B.	010 ( $\alpha = 0$ )	10

## 6.4 Graphics Processor Register Definitions

The registers associated with the Graphics Processor (GP) are the Standard GeodeLink™ Device (GLD) MSR and Graphics Processor Configuration registers. Table 6-28 and Table 6-29 are register summary tables that include reset values and page references where the bit descriptions are provided.

The Standard GLD MSRs (accessed via the RDMSR and WRMSR instructions) control the Graphics Processor's behavior as a GLIU module. These registers should be programmed at configuration time and left alone thereafter. They do not need to be modified by software to set up any of the graphics primitives. The MSRs are 64 bits wide, although not all bits are used in each register. Unused bits marked as “write as read” return the value that was last written to them. All other unused bits return 0.

All of the GP registers are accessible by the CPU through memory mapped reads and writes on the GLIU. Note that due to the pipelining operation of the GP, the value returned during a read is the value stored in the slave register, while the value in the master register is the actual value being used by an ongoing BLT or vector operation.

Also note that the command buffer has the ability to write into the slave registers. There is no reason, therefore, to read registers other than the GP\_BLT\_STATUS, GP\_INT\_CNTRL, and command buffer registers while the command buffer is active.

Reserved bits, marked as “write as read,” indicate that there is a real register backing those bits, which may be used in some future implementation of the GP. Reserved register bits that do not have a register backing them always return a 0, regardless of what value software decides to write into them.

The GP register space occupies 4 KB of the memory map. The bottom 256 bytes are defined as access to GP's primary registers. The remainder of the lower 1K of address space is used to alias the host source register for the source channel, allowing REP MOVSB access. The upper 3K of address space is used to alias the host source register for channel 3. This is the only aliasing that is supported by the GP, so all register accesses should use the full 12-bit offset.

**Table 6-28. Standard GeodeLink™ Device MSRs Summary**

MSR Address	Type	Register Name	Reset Value	Reference
A0002000h	RO	GLD Capabilities MSR (GLD_MSR_CAP)	00000000_0003D4xxh	Page 256
A0002001h	R/W	GLD Master Configuration MSR (GLD_MSR_CONFIG)	00000000_00000000h	Page 256
A0002002h	R/W	GLD SMI MSR (GLD_MSR_SMI)	00000000_00000000h	Page 257
A0002003h	R/W	GLD Error MSR (GLD_MSR_ERROR)	00000000_00000000h	Page 257
A0002004h	R/W	GLD Power Management MSR (GLD_MSR_PM)	00000000_00000000h	Page 258
A0002005h	R/W	GLD Diagnostic MSR (GLD_MSR_DIAG)	00000000_00000000h	Page 258

**Table 6-29. Graphics Processor Configuration Register Summary**

GP Memory Offset	Type	Group	Register Name	Reset Value	Reference
00h	R/W	Address Config	Destination Offset (GP_DST_OFFSET)	00000000h	Page 259
04h	R/W	Address Config	Source Offset (GP_SRC_OFFSET)	00000000h	Page 259
04h	R/W	Vector Config	Vector Error (GP_VEC_ERR)	00000000h	Page 260
08h	R/W	Address Config	Stride (GP_STRIDE)	00000000h	Page 260
0Ch	R/W	BLT Config	BLT Width/Height (GP_WID_HEIGHT)	00000000h	Page 261
0Ch	R/W	Vector Config	Vector Length (GP_VEC_LEN)	00000000h	Page 261

Table 6-29. Graphics Processor Configuration Register Summary

GP Memory Offset	Type	Group	Register Name	Reset Value	Reference
10h	R/W	Color Config	Source Color Foreground (GP_SRC_COLOR_FG)	00000000h	Page 262
14h	R/W	Color Config	Source Color Background (GP_SRC_COLOR_BG)	00000000h	Page 263
18h-2Ch	R/W	Pattern Config	Pattern Color (GP_PAT_COLOR_x)	00000000h	Page 265
30h-34h	R/W	Pattern Config	Pattern Data (GP_PAT_DATA_x)	00000000h	Page 265
38h	R/W	BLT Config	Raster Mode (GP_RASTER_MODE)	00000000h	Page 265
3Ch	WO	Vector Config	Vector Mode (GP_VECTOR_MODE)	00000000h	Page 267
40h	WO	BLT Config	BLT Mode (GP_BLT_MODE)	00000000h	Page 268
44h	RO	BLT Config	Status (GP_BLT_STATUS)	00000008h	Page 269
44h	RO	Reset Gen	Reset (GP_RESET)	none	
48h	WO	BLT Data	Host Source (GP_HST_SRC)	xxxxxxxh	Page 269
4Ch	R/W	Address Config	Base Offset (GP_BASE_OFFSET)	01004010h	Page 270
50h	R/W	Command Buff	Command Top (GP_CMD_TOP)	01000000h	Page 270
54h	R/W	Command Buff	Command Bottom (GP_CMD_BOT)	00FFFE0h	Page 271
58h	R/W	Command Buff	Command Read (GP_CMD_READ)	00000000h	Page 271
5Ch	R/W	Command Buff	Command Write (GP_CMD_WRITE)	00000000h	Page 272
60h	R/W	Channel3	Offset (GP_CH3_OFFSET)	00000000h	Page 272
64h	R/W	Channel3	Stride (GP_CH3_MODE_STR)	00000000h	Page 273
68h	R/W	Channel3	Width/Height (GP_CH3_WIDHI)	00000000h	Page 275
6Ch	WO	Channel3	Host Source (GP_CH3_HSRC)	xxxxxxxh	Page 275
70h	R/W	Channel3	LUT Index (GP_LUT_INDEX)	00000000h	Page 276
74h	R/W	Channel3	LUT Data (GP_LUT_DATA)	xxxxxxxh	Page 276
78h	R/W	Interrupt Control	Interrupt Control (GP_INT_CNTRL)	0000FFFFh	Page 277
3FF:100h	WO	BLT Data	Host Source (GP_HST_SRC) (alias)	xxxxxxxh	Page 269
FFF:400h	WO	Channel3	Host Source (GP_CH3_HSRC) (alias)	xxxxxxxh	Page 275

### 6.4.1 Standard GeodeLink™ Device (GLD) MSRs

#### 6.4.1.1 GLD Capabilities MSR (GLD\_MSR\_CAP)

MSR Address A0002000h  
 Type RO  
 Reset Value 00000000\_0003D4xxh

This MSR contains the revision and device IDs for the particular implementation of the Graphics Processor. This register is read only.

#### GLD\_MSR\_CAP Register Map

63	62	61	60	59	58	57	56	55	54	53	52	51	50	49	48	47	46	45	44	43	42	41	40	39	38	37	36	35	34	33	32
RSVD																															
31	30	29	28	27	26	25	24	23	22	21	20	19	18	17	16	15	14	13	12	11	10	9	8	7	6	5	4	3	2	1	0
RSVD				CLKDOM				DID														RID									

#### GLD\_MSR\_CAP Bit Descriptions

Bit	Name	Description
63:27	RSVD	<b>Reserved.</b>
26:24	CLKDOM	<b>Clock Domain.</b> Number of clock domains. The GP has one clock domain.
23:8	DID	<b>Device ID.</b> Identifies device (03D4h).
7:0	RID	<b>Revision ID.</b> Identifies device revision. See <i>AMD Geode™ LX Processors Specification Update</i> document for value.

#### 6.4.1.2 GLD Master Configuration MSR (GLD\_MSR\_CONFIG)

MSR Address A0002001h  
 Type R/W  
 Reset Value 00000000\_00000000h

This MSR contains the GLIU priority domain bits and priority level bits that are sent out to the GLIU on every GeodeLink transaction.

#### GLD\_MSR\_CONFIG Register Map

63	62	61	60	59	58	57	56	55	54	53	52	51	50	49	48	47	46	45	44	43	42	41	40	39	38	37	36	35	34	33	32
RSVD																															
31	30	29	28	27	26	25	24	23	22	21	20	19	18	17	16	15	14	13	12	11	10	9	8	7	6	5	4	3	2	1	0
RSVD				CBASE												RSVD															

#### GLD\_MSR\_CONFIG Bit Descriptions

Bit	Name	Description
63:28	RSVD	<b>Reserved.</b>
27:16	CBASE	<b>Command Buffer Base.</b> 16M region aligned to 1M boundary. See Section 6.3.1 "Command Buffer" on page 239 for details.
15:0	RSVD	<b>Reserved.</b>



**6.4.1.3 GLD SMI MSR (GLD\_MSR\_SMI)**

MSR Address A0002002h  
 Type R/W  
 Reset Value 00000000\_00000000h

This MSR contains the SMI and Mask bits for the GP. An SMI is asserted whenever an illegal address or an illegal type is detected on the GLIU and the mask bit is not set. This also causes the mb\_p\_asmi output to be asserted. This signal remains asserted until the SMI is cleared or the mask bit is set. An illegal address is defined as a memory mapped access to an address offset greater than 07Fh or an MSR access to an address greater than 20000007h. An illegal type is flagged if the GP receives a transaction whose type is not one of the following: NCOH\_READ, NCOH\_WRITE, NCOH\_READ\_BEX, MSR\_READ, MSR\_WRITE, BEX, NULL.

**GLD\_MSR\_SMI Register Map**

63	62	61	60	59	58	57	56	55	54	53	52	51	50	49	48	47	46	45	44	43	42	41	40	39	38	37	36	35	34	33	32
RSVD																															S
31	30	29	28	27	26	25	24	23	22	21	20	19	18	17	16	15	14	13	12	11	10	9	8	7	6	5	4	3	2	1	0
RSVD																															M

**GLD\_MSR\_SMI Bit Descriptions**

Bit	Name	Description
63:33	RSVD	<b>Reserved.</b> Read returns 0.
32	S	<b>SMI.</b> Indicates address or type violation. Write = 1 clears bit, write = 0 has no effect.
31:1	RSVD	<b>Reserved.</b> Read returns 0.
0	M	<b>Mask.</b> Ignore address and type violations when set; also disable ASMI output.

**6.4.1.4 GLD Error MSR (GLD\_MSR\_ERROR)**

MSR Address A0002003h  
 Type R/W  
 Reset Value 00000000\_00000000h

This MSR contains the Errors and Mask bits for the GP. An error is asserted whenever an illegal address or an illegal type is detected on the GLIU and the mask bit is not set. This also causes the internal mb\_p\_asmi output to be asserted if the Mask bit (MSR A0002002h[0]) is not set. The error bits remain asserted until they are cleared. An illegal address is defined as a memory mapped access to an address offset greater than 07Fh or an MSR access to an address greater than 20000007h. An illegal type is flagged if the GP receives a transaction whose type is not one of the following: NCOH\_READ, NCOH\_WRITE, NCOH\_READ\_BEX, MSR\_READ, MSR\_WRITE, BEX, NULL.

**GLD\_MSR\_ERROR Register Map**

63	62	61	60	59	58	57	56	55	54	53	52	51	50	49	48	47	46	45	44	43	42	41	40	39	38	37	36	35	34	33	32
RSVD																															
31	30	29	28	27	26	25	24	23	22	21	20	19	18	17	16	15	14	13	12	11	10	9	8	7	6	5	4	3	2	1	0
RSVD														AE	TE	RSVD											AM	TM			

## GLD\_MSR\_ERROR Bit Descriptions

Bit	Name	Description
63:18	RSVD	<b>Reserved.</b> Read returns 0.
17	AE	<b>Address Error.</b> 1 indicates address violation. Write = 1 clears bit, write = 0 has no effect.
16	TE	<b>Type Error.</b> 1 indicates type error. Write = 1 clears bit, write = 0 has no effect.
15:2	RSVD	<b>Reserved.</b> Read returns 0.
1	AM	<b>Address Mask.</b> Ignore address violations when set.
0	TM	<b>Type Mask.</b> Ignore type violations when set.

## 6.4.1.5 GLD Power Management MSR (GLD\_MSR\_PM)

MSR Address     A0002004h  
 Type            R/W  
 Reset Value    00000000\_00000000h

This MSR contains the power management controls for the GP. Since there is only one clock domain within the GP, most bits in this register are unused. This register allows the GP to be switched off by disabling the clocks to this block. If hardware clock gating is enabled, the GP will turn off its clocks whenever there is no BLT busy or pending and no GLIU transactions destined to the GP. A register or MSR write causes the GP to wake up temporarily to service the request, then return to power down. A write to the GP\_BLIT\_MODE or GP\_VECTOR\_MODE registers (GP Memory Offset 40h and 3Ch respectively) causes the GP to wake up for the duration of the requested operation. If software clock gating is enabled, a write to the PRQ bit causes the GP to stop its clocks the next time that it is idle. It automatically wakes itself up when it is busy again, clearing the PRQ bit.

## GLD\_MSR\_PM Register Map

63	62	61	60	59	58	57	56	55	54	53	52	51	50	49	48	47	46	45	44	43	42	41	40	39	38	37	36	35	34	33	32	PRQ
RSVD																																
31	30	29	28	27	26	25	24	23	22	21	20	19	18	17	16	15	14	13	12	11	10	9	8	7	6	5	4	3	2	1	0	PM
RSVD																																

## GLD\_MSR\_PM Bit Descriptions

Bit	Name	Description
63:33	RSVD	<b>Reserved.</b> Read returns 0.
32	PRQ	<b>Software Power Request.</b> If software clock gating is enabled, disable the clocks the next time the device is not busy. This bit is cleared when the device wakes up.
31:2	RSVD	<b>Reserved.</b> Read returns 0.
1:0	PM	<b>Power Mode.</b> 00: Disable clock gating. Clocks are always on. 01: Enable active hardware clock gating. 10: Enable software clock gating. 11: Enable hardware and software clock gating.

## 6.4.1.6 GLD Diagnostic MSR (GLD\_MSR\_DIAG)

MSR Address     A0002005h  
 Type            R/W  
 Reset Value    00000000\_00000000h

This register is reserved for internal use by AMD and should not be written to.

## 6.4.2 Graphics Processor Configuration Registers

### 6.4.2.1 Destination Offset (GP\_DST\_OFFSET)

GP Memory Offset 00h  
 Type R/W  
 Reset Value 00000000h

GP\_DST\_OFFSET is used to give a starting location for the destination of a BLT or vector in the destination region of memory. It consists of three fields, the OFFSET, XLSBS and YLSBS. The OFFSET is a pointer, which when added to the destination base address, gives the memory address of the first byte of the BLT or vector. For a left-to-right direction BLT or a vector, the address should be aligned to the least significant byte of the first pixel, since this is the leftmost byte. For a right-to-left direction BLT, the address should be aligned to the most significant byte of the first pixel, since this is the rightmost byte of the BLT. The address alignment must also be correct with respect to the pixel depth. In 32-bpp mode, the address specified must be aligned to the least significant or most significant byte of a DWORD, depending upon BLT direction. Pixels may not straddle a DWORD boundary. In 16-bpp mode, the address specified must be aligned to a 16-bit boundary. The XLSBS and YLSBS are used to inform the hardware of the location of the pixel within the pattern memory for pattern alignment.

**GP\_DST\_OFFSET Register Map**

31	30	29	28	27	26	25	24	23	22	21	20	19	18	17	16	15	14	13	12	11	10	9	8	7	6	5	4	3	2	1	0
YLSBS			XLSBS			RSVD			OFFSET																						

**GP\_DST\_OFFSET Bit Descriptions**

Bit	Name	Description
31:29	YLSBS	<b>Y LSBs.</b> Indicates Y coordinate of starting pixel within pattern memory.
28:26	XLSBS	<b>X LSBs.</b> Indicates X coordinate of starting pixel within pattern memory.
25:24	RSVD	<b>Reserved.</b> Write as read.
23:0	OFFSET	<b>Offset.</b> Offset from the destination base address to the first destination pixel.

### 6.4.2.2 Source Offset (GP\_SRC\_OFFSET)

GP Memory Offset 04h  
 Type R/W  
 Reset Value 00000000h

GP\_SRC\_OFFSET is used during a BLT to give a starting location for the source in the source region of memory. In this mode, the register consists of two fields, the OFFSET and XLSBS. The OFFSET is a pointer, which when added to the source base address, gives the memory location of the byte containing the first pixel of the BLT. As in the destination offset, this value must be aligned correctly for BLT direction and pixel depth. When host source data is used, the two LSBs of the OFFSET must still be initialized with the byte location of the first source pixel in the host source data stream. The XLSBSs are used when the source is monochrome to give an offset within the specified byte to the bit representing the starting pixel. In byte-packed mode, the XLSBSs are used to index into the first byte of every new line of source data. In unpacked mode, both the OFFSET and XLSBSs are used to index into the first DWORD of every new line of source data.

**GP\_SRC\_OFFSET Register Map**

31	30	29	28	27	26	25	24	23	22	21	20	19	18	17	16	15	14	13	12	11	10	9	8	7	6	5	4	3	2	1	0
RSVD			XLSBS			RSVD			OFFSET																						

**GP\_SRC\_OFFSET Bit Descriptions**

Bit	Name	Description
31:29	RSVD	<b>Reserved.</b> Write as read.
28:26	XLSBS	<b>X LSBs.</b> Offset within byte to first monochrome pixel.

**GP\_SRC\_OFFSET Bit Descriptions (Continued)**

Bit	Name	Description
25:24	RSVD	<b>Reserved.</b> Write as read.
23:0	OFFSET	<b>Offset.</b> Offset from the source base address to the first source pixel.

**6.4.2.3 Vector Error (GP\_VEC\_ERR)**

GP Memory Offset 04h  
 Type R/W  
 Reset Value 00000000h

This register specifies the axial and diagonal error terms used by the Bresenham vector algorithm. GP\_VEC\_ERR shares the same storage space as GP\_SRC\_OFFSET and thus a write to one of these registers will be reflected in both, since they both have the same offset. The name change is only for documentation purposes.

**GP\_VEC\_ERR Register Map**

31	30	29	28	27	26	25	24	23	22	21	20	19	18	17	16	15	14	13	12	11	10	9	8	7	6	5	4	3	2	1	0
A_ERR																D_ERR															

**GP\_VEC\_ERR Bit Description**

Bit	Name	Description
31:16	A_ERR	<b>Axial Error Term.</b> Axial error term (2's complement format).
15:0	D_ERR	<b>Diagonal Error Term.</b> Diagonal error term (2's complement format).

**6.4.2.4 Stride (GP\_STRIDE)**

GP Memory Offset 08h  
 Type R/W  
 Reset Value 00000000h

The GP\_STRIDE register is used to indicate the byte width of the destination and source images. Whenever the Y coordinate is incremented, this value is added to the previous start address to generate the start address for the next line. Stride values up to 64 KB minus one are supported. Adding the GP\_STRIDE to the OFFSET gives the byte address for the first pixel of the next line of a BLT. In the case of monochrome source, the XLSBs specified in the GP\_SRC\_OFFSET register are used to index into the first byte of every line to extract the first pixel.

Note that the Display Controller may not support variable strides for on-screen space, especially when compression is enabled. Refer to DC Memory Offset 034h[15:0] for frame buffer pitch. Display Controller restrictions do not apply to source stride.

When copying from on-screen frame buffer space (e.g., window move), the values of S\_STRIDE and D\_STRIDE should match. When copying from off-screen space, S\_STRIDE should be the number of bytes to add to get from one line in the source bitmap to the next. This allows software to linearly pack a bitmap into off-screen space (e.g., for an 800x600 monochrome bitmap packed linearly into off-screen space, bytes per line is 100, so S\_STRIDE should be written with 100).

**GP\_STRIDE Register Map**

31	30	29	28	27	26	25	24	23	22	21	20	19	18	17	16	15	14	13	12	11	10	9	8	7	6	5	4	3	2	1	0
S_STRIDE																D_STRIDE															

## GP\_STRIDE Bit Descriptions

Bit	Name	Description
31:16	S_STRIDE	<b>Source Stride.</b> Width of the source bitmap (in bytes).
15:0	D_STRIDE	<b>Destination Stride.</b> Width of the destination scan line (in bytes).

## 6.4.2.5 BLT Width/Height (GP\_WID\_HEIGHT)

GP Memory Offset 0Ch

Type R/W

Reset Value 00000000h

This register is used to specify the width and the height of the BLT in pixels. Note that operations that extend beyond the bounds of the frame buffer space “wrap” into the other end of the frame buffer.

## GP\_WID\_HEIGHT Register Map

31	30	29	28	27	26	25	24	23	22	21	20	19	18	17	16	15	14	13	12	11	10	9	8	7	6	5	4	3	2	1	0
RSVD				WID												RSVD				HI											

## GP\_WID\_HEIGHT Bit Descriptions

Bit	Name	Description
31:28	RSVD	<b>Reserved.</b> Write as read.
27:16	WID	<b>Width.</b> Width in pixels of the BLT operation.
15:12	RSVD	<b>Reserved.</b> Write as read.
11:0	HI	<b>Height.</b> Height in pixels of the BLT operation.

## 6.4.2.6 Vector Length (GP\_VEC\_LEN)

GP Memory Offset 0Ch

Type R/W

Reset Value 00000000h

This register is used to specify the length of the vector in pixels and the initial error term. Note that this is the same register as GP\_WID\_HEIGHT, and that writing to one overwrites the other. They are separated for documentation purposes. As with BLT operations, vectors that extend below or above the frame buffer space wrap to the other end of the frame buffer.

## GP\_VEC\_LEN Register Map

31	30	29	28	27	26	25	24	23	22	21	20	19	18	17	16	15	14	13	12	11	10	9	8	7	6	5	4	3	2	1	0
RSVD				LEN												I_ERR															

## GP\_VEC\_LEN Bit Descriptions

Bit	Name	Description
31:28	RSVD	<b>Reserved.</b> Write as read.
27:16	LEN	<b>Length.</b> Length of the vector in pixels.
15:0	I_ERR	<b>Initial Error.</b> Initial error for rendering a vector (2's complement format).

**6.4.2.7 Source Color Foreground (GP\_SRC\_COLOR\_FG)**

GP Memory Offset 10h  
 Type R/W  
 Reset Value 00000000h

When source data is monochrome, the contents of this register are used for expanding pixels that are set in the monochrome bitmap, thus replacing the monochrome bit with a color that is appropriately sized for the destination.

When source data is color, this register contains the color key for transparency. The value(s) in this register is XOR'ed with the color source data, after which the GP\_SRC\_COLOR\_BG register (GP Memory Offset 14h) is used to mask out bits that are don't cares. If all bits of a pixel that are not masked off compare, and source transparency is enabled, then the write of that pixel will be inhibited and the frame buffer data will be unchanged. Otherwise, the frame buffer will be written with the color data resulting from the raster operation.

If no source is required for a given BLT, the value of this register is used as the default source data into the raster operation.

This register should only be written after setting the bpp in GP\_RASTER\_MODE (GP Memory Offset 38h), since the value written is replicated as necessary to fill the register. Thus a write to this register in 8-bpp mode takes the least significant data byte and replicates it in the four bytes of the register. In 16-bpp mode, the least significant two bytes are replicated in the upper half of the register. A read returns the replicated data.

**GP\_SRC\_COLOR\_FG Register Map**

31	30	29	28	27	26	25	24	23	22	21	20	19	18	17	16	15	14	13	12	11	10	9	8	7	6	5	4	3	2	1	0
SRC_FG																															

**GP\_SRC\_COLOR\_FG Bit Descriptions**

Bit	Name	Description
31:0	SRC_FG	<p><b>Source Foreground.</b></p> <p>Mono source mode: Foreground source color.                      Color source mode: Color key for transparency.</p>

**6.4.2.8 Source Color Background (GP\_SRC\_COLOR\_BG)**

GP Memory Offset 14h

Type R/W

Reset Value 00000000h

When source data is monochrome, the contents of this register are used for expanding pixels that are clear in the monochrome bitmap, thus replacing the monochrome bit with a color that is appropriately sized for the destination.

When source data is color, this register contains the color key mask for transparency. The value(s) in this register are inverted and OR'ed with the result of the compare of the source data and the GP\_SRC\_COLOR\_FG register. Thus, a bit that is clear implies that bit position is a don't care for transparency, and a bit that is set implies that bit position must match in both the source data and GP\_SRC\_COLOR\_FG register. If the result of the OR produces all ones for an entire pixel and transparency is enabled, then the write of that pixel is inhibited and the destination data is unchanged.

This register should only be written after setting the BPP/FMT bits in GP\_RASTER\_MODE (GP Memory Offset 38h[31:28]), since the value written is replicated as necessary to fill the register. Thus a write to this register in 8-bpp mode takes the least significant data byte and replicates it in all four bytes of the register. In 16-bpp mode, the least significant two bytes are replicated in the upper half of the register. A read returns the replicated data.

**GP\_SRC\_COLOR\_BG Register Map**

31	30	29	28	27	26	25	24	23	22	21	20	19	18	17	16	15	14	13	12	11	10	9	8	7	6	5	4	3	2	1	0
SRC_BG																															

**GP\_SRC\_COLOR\_BG Bit Descriptions**

Bit	Name	Description
31:0	SRC_BG	<b>Source Background.</b> Mono source mode: Background source color. Color source mode: Color key mask for transparency.

**6.4.2.9 Pattern Color (GP\_PAT\_COLOR\_x)**

GP Memory Offset	18h	GP_PAT_COLOR_0
	1Ch	GP_PAT_COLOR_1
	20h	GP_PAT_COLOR_2
	24h	GP_PAT_COLOR_3
	28h	GP_PAT_COLOR_4
	2Ch	GP_PAT_COLOR_5
Type		R/W
Reset Value		00000000h

In solid pattern mode, the pattern hardware is disabled and GP\_PAT\_COLOR\_0 is selected as the input to the raster operation.

In monochrome pattern mode, GP\_PAT\_COLOR\_0 and GP\_PAT\_COLOR\_1 are used for expanding the monochrome pattern into color. A clear bit in the pattern is replaced with the color stored in GP\_PAT\_COLOR\_0 and a set bit in the pattern is replaced with the color stored in GP\_PAT\_COLOR\_1.

In color pattern mode, these registers each hold part of the pattern according to Table 6-30.

**Table 6-30. PAT\_COLOR Usage for Color Patterns**

Register	8-bpp Mode	16-bpp Mode	32-bpp Mode
GP_PAT_COLOR_0	Line 1, pixels 3-0	Line 0, pixels 5-4	Line 0, pixel 2
GP_PAT_COLOR_1	Line 1, pixels 7-4	Line 0, pixels 7-6	Line 0, pixel 3
GP_PAT_COLOR_2	Line 2, pixels 3-0	Line 1, pixels 1-0	Line 0, pixel 4
GP_PAT_COLOR_3	Line 2, pixels 7-4	Line 1, pixels 3-2	Line 0, pixel 5
GP_PAT_COLOR_4	Line 3, pixels 3-0	Line 1, pixels 5-4	Line 0, pixel 6
GP_PAT_COLOR_5	Line 3, pixels 7-4	Line 1, pixels 7-6	Line 0, pixel 7

These registers should only be written after setting the BPP/FMT and PM bits in GP\_RASTER\_MODE (GP Memory Offset 38h[31:28, 9:8]), since the value written may be replicated if necessary to fill the register. If the pattern is color, no replication is performed and the data is written to the registers exactly as it is received. If the pattern is monochrome, the write data is expanded if the color depth is less than 32-bpp. Thus a write to these registers in 8-bpp monochrome pattern mode takes the least significant data byte and replicates it in the four bytes of the register. In 16-bpp monochrome pattern mode, the least significant two bytes are replicated in the upper half of the register. A read returns the replicated data.

**GP\_PAT\_COLOR\_x Register Map**

31	30	29	28	27	26	25	24	23	22	21	20	19	18	17	16	15	14	13	12	11	10	9	8	7	6	5	4	3	2	1	0
PAT_COLOR_x																															

**GP\_PAT\_COLOR\_x Bit Descriptions**

Bit	Name	Description
31:0	PAT_COLOR_x	<b>Pattern Color x.</b> Mono pattern mode: Pattern color for expansion. Color pattern mode: Color pattern.



**6.4.2.10 Pattern Data (GP\_PAT\_DATA\_x)**

GP Memory Offset	30h	GP_PAT_DATA_0
	34h	GP_PAT_DATA_1
Type		R/W
Reset Value		00000000h

In solid pattern mode, these registers are not used.

In monochrome pattern mode, GP\_PAT\_DATA\_0 and GP\_PAT\_DATA\_1 combine to hold the entire 8x8 pattern (64 bits). GP\_PAT\_DATA\_0[7:0] is the first line of the pattern, with bit 7 corresponding to the leftmost pixel on the screen. GP\_PAT\_DATA\_1[31:24] is the last line of the pattern.

In color pattern mode, these registers each hold part of the pattern according to Table 6-31.

**Table 6-31. PAT\_DATA Usage for Color Patterns**

Register	8-bpp Mode	16-bpp Mode	32-bpp Mode
GP_PAT_DATA_0	Line 0, pixels 3-0	Line 0, pixels 1-0	Line 0, pixel 0
GP_PAT_DATA_1	Line 0, pixels 7-4	Line 0, pixels 3-2	Line 0, pixel 1

**GP\_PAT\_DATA\_x Register Map**

31	30	29	28	27	26	25	24	23	22	21	20	19	18	17	16	15	14	13	12	11	10	9	8	7	6	5	4	3	2	1	0
PAT_DATA_x																															

**GP\_PAT\_DATA\_x Bit Descriptions**

Bit	Name	Description
31:0	PAT_DATA_x	<b>Pattern Data x.</b> Mono pattern mode: Pattern data. Color pattern mode: Color pattern.

**6.4.2.11 Raster Mode (GP\_RASTER\_MODE)**

GP Memory Offset	38h
Type	R/W
Reset Value	00000000h

This register controls the manipulation of the pixel data through the graphics pipeline. Refer to section Section 6.3.10 "Raster Operations (ROP)" on page 251 for more information on the functionality of the ROP and Section 6.3.11 "Image Compositing Using Alpha" on page 252 for information on alpha blending and compositing. This register is byte writable to allow modification of the ROP and other control bits without having to rewrite the BPP and FMT every time.

**GP\_RASTER\_MODE Register Map**

31	30	29	28	27	26	25	24	23	22	21	20	19	18	17	16	15	14	13	12	11	10	9	8	7	6	5	4	3	2	1	0
BPP/FMT		RSVD			EN	OS	AS		Ⓞ	RSVD	SI	PI	ST	PT	PM	ROP/a <sub>R</sub>															

## GP\_RASTER\_MODE Bit Descriptions

Bit	Name	Description
31:28	BPP/FMT	<b>Color Depth and Format.</b> 0000: 8-bpp, 3:3:2 format. 0100: 16-bpp, 4:4:4:4 format. 0101: 16-bpp, 1:5:5:5 format. 0110: 16-bpp, 0:5:6:5 format. 1000: 32-bpp, 8:8:8:8 format. All Others: Undefined.
27:24	RSVD	<b>Reserved.</b> Write as read.
23:22	EN	<b>Alpha Enable Bits.</b> Also used to select how to apply the specified operation. 00: Alpha disabled/ROP enabled. 01: Alpha operation applies to only the RGB values of the pixel. Output alpha is from channel B if the OS is 01; otherwise from channel A. 10: Alpha operation applies to only the alpha of the pixel. Output RGB is from channel B if the OS is 01; otherwise from channel A. 11: Alpha operation applies to all channels of the pixel (ARGB).
21:20	OS	<b>Alpha Operation Select.</b> Determines the alpha operation to be performed if enabled. 00: $a \cdot A$ . 01: $(1-a) \cdot B$ . 10: $A + (1-a) \cdot B$ . 11: $a \cdot A + (1-a) \cdot B$ . * Channel A is added in this case only if the selected $\alpha$ is also from channel A.
19:17	AS	<b>Alpha Select.</b> Chooses which alpha value to use for the multiplication. 000: $a_A$ 100: $Color_A$ 001: $a_B$ 101: $Color_B$ 010: $a_R$ 110: $a_R$ 011: Constant 1                      111: Constant 1
16	CS	<b>Channel Select.</b> Determines which data stream gets put on which channel. 0: A is source, B is destination. 1: A is destination, B is source.
15:14	RSVD	<b>Reserved.</b> Write as read.
13	SI	<b>Source Invert.</b> Inverts the sense of monochrome source data.
12	PI	<b>Pattern Invert.</b> Inverts the sense of monochrome pattern data.
11	ST	<b>Source Transparency.</b> Enables transparency for monochrome source data and color keying for color source data. 0: Disable. 1: Enable.
10	PT	<b>Pattern Transparency.</b> Enables transparency for monochrome pattern data. 0: Disable. 1: Enable.
9:8	PM	<b>Pattern Mode.</b> Specifies the format of the pattern data. 00: Solid pattern. Pattern data always sourced from GP_PAT_COLOR_0 (GP Memory Offset 18h). 01: Mono pattern. 10: Color pattern. 11: Undefined.

## GP\_RASTER\_MODE Bit Descriptions (Continued)

Bit	Name	Description
7:0	ROP/a <sub>R</sub>	<p><b>Raster Operations (ROP).</b> Combination rule for source, pattern and destination when performing raster operations. (See Section 6.3.10 "Raster Operations (ROP)" on page 251.)</p> <p><b>Alpha Value (a<sub>R</sub>).</b> Alpha value that can be used for some of the alpha compositing operations.</p>

## 6.4.2.12 Vector Mode (GP\_VECTOR\_MODE)

GP Memory Offset 3Ch

Type WO

Reset Value 00000000h

Writing to this register configures the vector mode and initiates the rendering of the vector. If a BLT or vector operation is already in progress when this register is written, the BLT pending bit in GP\_BLT\_STATUS (GP Memory Offset 44h) is set and the vector is queued to begin when the current operation is complete. Software should not write to any register (other than GP\_HOST\_SRC if required) while the BLT pending bit is set since it will corrupt the pending vector operation. Setting the TH bit causes the vector operation to wait until the next VBLANK before beginning rendering. Software may still queue another operation behind a throttled vector as long as the BLT pending bit is clear.

## GP\_VECTOR\_MODE Register Map

31	30	29	28	27	26	25	24	23	22	21	20	19	18	17	16	15	14	13	12	11	10	9	8	7	6	5	4	3	2	1	0
RSVD																								CP	TH	DR	DN	DJ	YJ		

## GP\_VECTOR\_MODE Bit Descriptions

Bit	Name	Description
31:6	RSVD	<b>Reserved.</b> Write to 0.
5	CP	<b>Checkpoint.</b> Generates interrupt when this vector is completed if checkpoint interrupt is enabled.
4	TH	<p><b>Throttle.</b></p> <p>0: Operation begins immediately. 1: Operation waits until next VBLANK before beginning.</p>
3	DR	<p><b>Destination Required.</b></p> <p>0: Destination data is not needed for operation. 1: Destination data is needed from frame buffer.</p>
2	DN	<p><b>Minor Direction.</b></p> <p>0: Negative minor axis step. 1: Positive minor axis step.</p>
1	DJ	<p><b>Major Direction.</b></p> <p>0: Negative major axis step. 1: Positive major axis step</p>
0	YJ	<p><b>Y Major.</b></p> <p>0: X major vector. 1: Y major vector.</p>

**6.4.2.13 BLT Mode (GP\_BLT\_MODE)**

GP Memory Offset 40h  
 Type WO  
 Reset Value 00000000h

Writing to this register configures the BLT mode and initiates the rendering of the BLT. If a BLT or vector operation is already in progress when this register is written, the BLT pending bit in GP\_BLT\_STATUS (GP Memory Offset 44h) is set and the BLT is queued to begin when the current operation is complete. Software should not write to any register (other than GP\_HOST\_SRC if required) while the BLT pending bit is set since it will corrupt the pending BLT. Setting the TH bit causes the BLT operation to wait until the next VBLANK before beginning. Software may still queue another operation behind a throttled BLT as long as the BLT pending bit is clear.

**GP\_BLT\_MODE Register Map**

31	30	29	28	27	26	25	24	23	22	21	20	19	18	17	16	15	14	13	12	11	10	9	8	7	6	5	4	3	2	1	0				
RSVD																				0	TH	X	Y	SM	RSVD	DR	SR								

**GP\_BLT\_MODE Bit Descriptions**

Bit	Name	Description
31:12	RSVD	<b>Reserved.</b> Write to 0.
11	CP	<b>Checkpoint.</b> Generates interrupt when this BLT is completed if checkpoint interrupt is enabled.
10	TH	<b>Throttle.</b> BLT does not begin until next VBLANK. 0: Disable. 1: Enable.
9	X	<b>X Direction.</b> 0: Indicates a positive increment for the X position. 1: Indicates a negative increment for the X position.
8	Y	<b>Y Direction.</b> 0: Indicates a positive increment for the Y position. 1: Indicates a negative increment for the Y position.
7:6	SM	<b>Source Mode.</b> Specifies the format of the source data. 00: Source is color bitmap. 01: Source is unpacked monochrome. 10: Source is byte-packed monochrome. 11: Undefined.
5:3	RSVD	<b>Reserved.</b> Write as read.
2	DR	<b>Destination Required.</b> 0: No destination data is required. 1: Indicates that destination data is needed from frame buffer.
1:0	SR	<b>Source Required.</b> 00: No source data. 01: Source from frame buffer. 10: Source from GP_HST_SRC register (GP Memory Offset 48h). 11: Undefined.

**6.4.2.14 Status and Reset (GP\_BLT\_STATUS, GP\_RESET)**

GP Memory Offset 44h  
 Type RO  
 Reset Value 00000008h

This register is used to provide software with the current status of the GP in regards to operations pending and currently executing. A write to this register has no effect unless byte 3 is 69h, which causes a reset of the GP, losing all state information and discarding any active or pending BLT or vector. This is only intended to be used during debug to restore the GP in the event of a hang. It is not required as part of the initialization or power on sequence for GP.

**GP\_BLT\_STATUS Register Map**

31	30	29	28	27	26	25	24	23	22	21	20	19	18	17	16	15	14	13	12	11	10	9	8	7	6	5	4	3	2	1	0
RSVD																							UF	RP	EH	CE	SHE	PP	IN	PB	

**GP\_BLT\_STATUS Bit Descriptions**

Bit	Name	Description
31:8	RSVD	<b>Reserved.</b>
7	UF	<b>Underflow.</b> If bit is set, Channel 3 had too few pixels to complete the BLT.
6	RP	<b>Read Pending.</b> If bit is set, read request is waiting for data from GLIU.
5	EH	<b>Expecting Host Source Data.</b> If bit is set, current BLT is expecting to receive host source data on Channel 3.
4	CE	<b>Command Buffer Empty.</b> If bit is set, read and write pointers are equal.
3	SHE	<b>Source FIFO Half Empty.</b> If bit is set, source FIFO can accept another cache line of host source data.
2	PP	<b>Primitive Pending.</b> If bit is set, a second BLT or vector is in the queue behind the currently executing operation.
1	IN	<b>Interrupt Pending.</b> If bit is set, the GP interrupt signal is active.
0	PB	<b>Primitive Busy.</b> If bit is set, an operation is currently executing in the GP.

**6.4.2.15 Host Source (GP\_HST\_SRC)**

GP Memory Offset 48h  
 Type WO  
 Reset Value xxxxxxxxh

This register is used by software to load source data that is not originated in the frame buffer memory region. When performing a BLT that requires host source data, software should first set up all of the configuration registers that are required and initiate the BLT by writing to the GP\_BLT\_MODE register (GP Memory Offset 40h). This initiates the BLT in hardware, which then waits for writes to the GP\_HST\_SRC register. Software should then perform enough writes to this register to complete the BLT operation. Writes to this register are moved immediately into the source FIFO, allowing the CPU to perform successive writes. The EH bit in the GP\_BLT\_STATUS (GP Memory Offset 44h[5]) register indicates that the GP can accept another cache line (32 bytes) of data.

This register is also aliased to the address range 100h-3FFh to allow the processor to move large blocks of data to the GP through the repeat MOVS instruction. The GP throttles the incoming data by holding off register writes on the GLIU when the source FIFO is full.

**GP\_HST\_SRC Register Map**

31	30	29	28	27	26	25	24	23	22	21	20	19	18	17	16	15	14	13	12	11	10	9	8	7	6	5	4	3	2	1	0
HST_SRC																															

## GP\_HST\_SRC Bit Descriptions

Bit	Name	Description
31:0	HST_SRC	<b>Host Source Data.</b> Used during BLT in host source mode.

## 6.4.2.16 Base Offset (GP\_BASE\_OFFSET)

GP Memory Offset 4Ch

Type R/W

Reset Value 01004010h

This register is used to define the physical base addresses of the regions used for all GP read and write operations to memory. Each base defines a 16 MB region that begins on a 4 MB boundary. Thus the top two bits of the offset [23:22] are added to the base to identify the correct 4 MB region in memory for a given transfer. Because there are different bases defined for each potential source of data, each can come from a different memory region. If a memory operation goes beyond the 16 MB region that has been assigned, it wraps back to the beginning of the 16 MB region.

## GP\_BASE\_OFFSET Register Map

31	30	29	28	27	26	25	24	23	22	21	20	19	18	17	16	15	14	13	12	11	10	9	8	7	6	5	4	3	2	1	0
DBASE										SBASE										CH3BASE						RSVD					

## GP\_BASE\_OFFSET Bit Descriptions

Bit	Name	Description
31:22	DBASE	<b>Destination Base.</b> Base address of destination data region in physical memory.
21:12	SBASE	<b>Source Base.</b> Base address of source data region in physical memory.
11:2	CH3BASE	<b>Channel 3 Base.</b> Base address of channel 3 data region in physical memory.
1:0	RSVD	<b>Reserved.</b>

## 6.4.2.17 Command Top (GP\_CMD\_TOP)

GP Memory Offset 50h

Type R/W

Reset Value 01000000h

This register defines the starting address of the command buffer within the command buffer region. Bits [23:0] of this register are combined with the CBASE in GLD\_MSR\_CONFIG (MSR A0002001h) to form the 32-bit address. This register should only be changed when the GP is not actively executing out of the command buffer, which can be checked by reading the CE bit in the GP\_BLT\_STATUS register (GP Memory Offset 44h[4]) or by verifying that GP\_CMD\_READ (GP Memory Offset 58h) and GP\_CMD\_WRITE (GP Memory Offset 5Ch) have the same value.

## GP\_CMD\_TOP Register Map

31	30	29	28	27	26	25	24	23	22	21	20	19	18	17	16	15	14	13	12	11	10	9	8	7	6	5	4	3	2	1	0
RSVD									CMD_TOP										RSVD												

## GP\_CMD\_TOP Bit Descriptions

Bit	Name	Description
31:24	RSVD	<b>Reserved.</b> Read returns 0.
23:5	CMD_TOP	<b>Command Top.</b> Starting address of the command buffer in the command buffer region.
4:0	RSVD	<b>Reserved.</b> Read returns 0.

**6.4.2.18 Command Bottom (GP\_CMD\_BOT)**

GP Memory Offset 54h  
 Type R/W  
 Reset Value 00FFFFFF0h

This register defines the ending address of the command buffer within the command buffer region. Bits [23:0] of this register are combined with the CBASE in GLD\_MSR\_CONFIG (MSR A0002001h) to form the 32 bit address. This register should only be changed when the GP is not actively executing out of the command buffer, which can be checked by reading the CE bit in GP\_BLT\_STATUS (GP Memory Offset 44h[4]) or by verifying that GP\_CMD\_READ and GP\_CMD\_WRITE (GP Memory Offset 58h and 5Ch respectively) have the same value.

**GP\_CMD\_BOT Register Map**

31	30	29	28	27	26	25	24	23	22	21	20	19	18	17	16	15	14	13	12	11	10	9	8	7	6	5	4	3	2	1	0
RSVD								CMD_BOT																RSVD							

**GP\_CMD\_BOT Bit Descriptions**

Bit	Name	Description
31:24	RSVD	<b>Reserved.</b> Read returns 0.
23:5	CMD_BOT	<b>Command Bottom.</b> Ending address of the command buffer in the command buffer region.
4:0	RSVD	<b>Reserved.</b> Read returns 0.

**6.4.2.19 Command Read (GP\_CMD\_READ)**

GP Memory Offset 58h  
 Type R/W  
 Reset Value 00000000h

This register points to the location from which the GP fetches the next command buffer data. As data is fetched, this register increments. When this register equals GP\_CMD\_BOT (GP Memory Offset 54h) and the data has been fetched, it is reloaded with the value from GP\_CMD\_TOP (GP Memory Offset 50h). If the current command buffer had the W (wrap) bit set in the command word, then this register is reset to GP\_CMD\_TOP after the execution of the current command buffer. Typically, this register is read only by the software, and is used in combination with GP\_CMD\_WRITE (GP Memory Offset 5Ch) to determine how much space is available in the command buffer for new commands. However, this register can be written. A write to this register also affects the GP\_CMD\_WRITE register such that when creating and initializing a new command buffer in memory, the read and write pointers can be updated simultaneously to point to the beginning of the buffer without the GP thinking that the buffer was non-empty and beginning to fetch. This register must not be written while the GP is actually executing command buffers as this could cause the GP to hang.

**GP\_CMD\_READ Register Map**

31	30	29	28	27	26	25	24	23	22	21	20	19	18	17	16	15	14	13	12	11	10	9	8	7	6	5	4	3	2	1	0
RSVD								CMD_READ																							

**GP\_CMD\_READ Bit Descriptions**

Bit	Name	Description
31:24	RSVD	<b>Reserved.</b> Read returns 0.
23:0	CMD_READ	<b>Command Read.</b> Pointer to the tail of the command buffer in the command buffer region.

#### 6.4.2.20 Command Write (GP\_CMD\_WRITE)

GP Memory Offset 5Ch  
 Type R/W  
 Reset Value 00000000h

This register points to the next location to be written with command buffer data from the processor. After the processor writes out a complete command buffer starting at this address, it should write to this register to update the value to point to the next location to be written. This write is what queues the GP that there is command buffer data that needs to be fetched and activates the command buffer logic within GP. If the Wrap bit is set in a command buffer control WORD, this register should be written with the same value as that found in GP\_CMD\_TOP (GP Memory Offset 50h) after the CPU has completed loading the command buffer in memory.

#### GP\_CMD\_WRITE Register Map

31	30	29	28	27	26	25	24	23	22	21	20	19	18	17	16	15	14	13	12	11	10	9	8	7	6	5	4	3	2	1	0
RSVD								CMD_WRITE																							

#### GP\_CMD\_WRITE Bit Descriptions

Bit	Name	Description
31:24	RSVD	<b>Reserved.</b> Read returns 0.
23:0	CMD_WRITE	<b>Command Write.</b> Pointer to where the next command buffer will be written in the command buffer region.

#### 6.4.2.21 Offset (GP\_CH3\_OFFSET)

GP Memory Offset 60h  
 Type R/W  
 Reset Value 00000000h

The GP\_CH3\_OFFSET register is used during a BLT to give a starting location for the BLT data in the channel 3 region of memory. The register consists of two fields to compose the address, the OFFSET and Nibble Select. The OFFSET field is a pointer, which when added to the channel 3 base address, gives the memory location of the byte containing the first pixel of the BLT. As in the destination and source offsets, this value must be aligned correctly for BLT direction and pixel depth. When host source data is used, the two LSBs of OFFSET must still be initialized with the byte location of the first source pixel in the host source data stream. Nibble Select is used when the source is 4-bpp, to give an offset within the specified byte to the nibble representing the starting pixel. Both the OFFSET LSBs and Nibble Select are used to index into the first DWORD of every new line of source data.

For a rotation of 90° counterclockwise, the offset should point to the top rightmost byte of the source bitmap. For a rotation of 90° clockwise, the offset should point to the bottom leftmost byte of the source bitmap. For a rotation of 180°, the offset should point to the opposite corner from that pointed to by the destination offset (e.g., If GP\_BLT\_MODE (GP Memory Offset 40h) indicates a left to right, top to bottom fill, then the destination offset should point to the upper left corner and the channel 3 offset should point to the bottom right most byte of the source bitmap).

#### GP\_CH3\_OFFSET Register Map

31	30	29	28	27	26	25	24	23	22	21	20	19	18	17	16	15	14	13	12	11	10	9	8	7	6	5	4	3	2	1	0
YLSBS			XLSBS			N	RSVD	OFFSET																							



## GP\_CH3\_OFFSET Bit Descriptions

Bit	Name	Description
31:29	YLSBS	<b>YLSBS.</b> Y coordinate of starting pixel within color pattern memory.
28:26	XLSBS	<b>XLSBS.</b> X coordinate of starting pixel within color pattern memory.
25	N	<b>Nibble Select.</b> Nibble address for 4-bpp pixels/alpha. 0 starts at the leftmost nibble, 1 starts at the rightmost.
24	RSVD	<b>Reserved.</b> Write as read.
23:0	OFFSET	<b>Offset.</b> Offset from the channel 3 base address to the first source pixel.

## 6.4.2.22 Stride (GP\_CH3\_MODE\_STR)

GP Memory Offset 64h

Type R/W

Reset Value 00000000h

The GP\_CH3\_MODE\_STR register has multiple uses. The STRIDE field is used to indicate the byte width of the channel 3 bitmaps. Whenever the Y coordinate is incremented, this value is added (or subtracted if the Y bit is set) to (from) the previous start address to generate the start address for the next line. Stride values up to 64 KB minus one are supported.

The remaining fields of this register describe the type, size and source of the channel 3 data. The output of channel 3 can be used to replace either source or pattern data into the ROP unit. The PS bit is used to select which pipeline the data will be placed on. If the FMT indicates that the incoming data is alpha, then the incoming data can be used as alpha data in the alpha blend unit if the AS bits in the GP\_RASTER\_MODE (GP Memory Offset 38h[19:17]) register are set to 110. If the BPP/FMT bits in the GP\_RASTER\_MODE register (bits [31:28]) indicate the output pixel is 32-bpp, then the incoming alpha data is converted to 8 bits and is consumed at the rate of one pixel per clock. If the BPP/FMT bits are set for 16-bpp, then the incoming alpha data is converted to 4 bits and is consumed at the rate of two pixels per clock. Alpha blending is not supported in 8-bpp mode.

Some operating systems store color data in reverse color order (Blue/Green/Red). This data can be converted into the correct display order by setting the BGR bit. This works for all input formats except for alpha, so if the incoming data is alpha, do not set this bit.

Rotation is controlled by the RO bit. If this bit is set, the direction of rotation is determined by the X and Y bits. When this bit is set, the GP\_DST\_OFFSET (GP Memory Offset 00h) should point to the upper left corner of the destination and the X and Y bits in the GP\_BLT\_MODE (GP Memory Offset 40h[9,8]) should not be set. The output must be left to right, top to bottom. The output is actually written in horizontal strips, 8, 16 or 32 pixels high and as wide as the output. For 8-bpp rotation, 1K of buffer space is the minimum required to perform the operation. Having 2K available allows data to be prefetched while the previous tile is being written out. Setting the PL bit limits the buffer size to 1K as it preserves the LUT data in the other 1K of the buffer. This bit should be set when performing any indexed color BLT or if it is likely that the LUT data that has been loaded will be needed again for a future BLT. The performance is higher when this bit is not set.

## GP\_CH3\_MODE\_STR Register Map

31	30	29	28	27	26	25	24	23	22	21	20	19	18	17	16	15	14	13	12	11	10	9	8	7	6	5	4	3	2	1	0
EN	PS	X	Y	BPP/FMT		RO	BGR	PM	PL	PE	HS	RSVD	STRIDE																		

## GP\_CH3\_MODE\_STR Bit Descriptions

Bit	Name	Description
31	EN	<b>Enable.</b> 0: Channel 3 is off. Old pipelines behave exactly as they used to. 1: Channel 3 is on. Data is forced into either source or pattern pipeline from channel 3.
30	PS	<b>Pipeline Select.</b> 0: Channel 3 data directed to/replaces old pattern pipeline. 1: Channel 3 data directed to/replaces old source pipeline

## GP\_CH3\_MODE\_STR Bit Descriptions (Continued)

Bit	Name	Description
29	X	<b>X Direction for Fetch.</b> Data is reversed if fetch direction does not match destination direction. 0: Left to right direction. 1: Right to left direction.
28	Y	<b>Y Direction for Fetch.</b> Data is reversed if fetch direction does not match destination direction. 0: Top to bottom direction. 1: Bottom to top direction.
27:24	BPP/FMT	<b>Color Depth and Format of Input.</b> 0000: 8-bpp 3:3:2. 0001: 8-bpp indexed. 0010: 8-bpp alpha. 0100: 16-bpp 4:4:4:4. 0110: 16-bpp 0:5:6:5. 0111: 4:2:2 YUV. 1000: 32-bpp. 1011: 24-bpp packed. 1101: 4-bpp indexed. 1110: 4-bpp alpha. All others: Undefined.
23	RO	<b>Rotate Bitmap.</b> 0: Disable rotation. 1: Enable rotation direction determined by X and Y. See Section 6.3.2.1 "Rotating BLTs" on page 242.
22	BGR	<b>BGR Mode (applies only when 16-bpp or 32-bpp).</b> 0: Pass through (or YUY2 for 4:2:2 mode). 1: Swap red and blue channels on output (or UYVY for 4:2:2 mode).
21	PM	<b>Pattern Mode.</b> 0: Bitmap mode, data from memory or host source. 1: Pattern mode.
20	PL	<b>Preserve LUT Data.</b> 0: Entire 2K buffer available for fetch data. 1: 1K reserved for LUT.
19	PE	<b>Prefetch Enable.</b> When this bit is set, data may be fetched while the BLT is still pending.
18	HS	<b>Host Source.</b> 0: Data fetched from memory. 1: Data written through host source writes.
17:16	RSVD	<b>Reserved.</b>
15:0	STRIDE	<b>Stride.</b> Increment between lines of bitmap in bytes.

**6.4.2.23 Width/Height (GP\_CH3\_WIDHI)**

GP Memory Offset 68h

Type R/W

Reset Value 00000000h

This register is used to specify the width and the height of the bitmap to be fetched on channel 3 in pixels. This need not match the destination width and height, as in the case of a rotation BLT where the width and height are swapped, but the total number of pixels should be equal to the number of pixels in the destination.

**GP\_CH3\_WIDHI Register Map**

31	30	29	28	27	26	25	24	23	22	21	20	19	18	17	16	15	14	13	12	11	10	9	8	7	6	5	4	3	2	1	0
RSVD				WID												RSVD				HI											

**GP\_CH3\_WIDHI Bit Descriptions**

Bit	Name	Description
31:28	RSVD	<b>Reserved.</b> Write as read.
27:16	WID	<b>Width.</b> Width in pixels of the BLT operation.
15:12	RSVD	<b>Reserved.</b> Write as read.
11:0	HI	<b>Height.</b> Height in pixels of the BLT operation.

**6.4.2.24 Host Source (GP\_CH3\_HSRC)**

GP Memory Offset 6Ch

Type WO

Reset Value xxxxxxxh

This register is used by software to load channel 3 data when the channel 3 pattern mode bit is not set, the channel 3 enable bit is set, and the channel 3 host source bit is set. This register is also aliased to the address range 400h-FFFh allowing the processor to load large blocks of data to the GP using the repeat MOVS instruction.

**GP\_CH3\_HSRC Register Map**

31	30	29	28	27	26	25	24	23	22	21	20	19	18	17	16	15	14	13	12	11	10	9	8	7	6	5	4	3	2	1	0
HST_SRC																															

**GP\_CH3\_HSRC Bit Descriptions**

Bit	Name	Description
31:0	HST_SRC	<b>Host Source Data.</b> Used during BLT in host source mode

**6.4.2.25 LUT Index (GP\_LUT\_INDEX)**

GP Memory Offset 70h  
 Type R/W  
 Reset Value 00000000h

This register is used to initialize the LUT\_INDEX pointer that is used for subsequent LUT operations. All LUT accesses are DWORD accesses so only the 9 LSBs of the pointer are used to index into the 2 KB LUT. Addresses 000h-0FFh are used for 8-bit indexed LUT data. Addresses 000h-00Fh are used for 4-bit indexed LUT data. Addresses 100h-13Fh are used for storing color patterns. All addresses are used for storing incoming data (unless the PL bit is set in the GP\_CH3\_MODE\_STR register, GP Memory Offset 64h[20]), but none of the remaining addresses have any significance to software.

**GP\_CH3\_HSRC Register Map**

31	30	29	28	27	26	25	24	23	22	21	20	19	18	17	16	15	14	13	12	11	10	9	8	7	6	5	4	3	2	1	0
RSVD																LUT_INDEX															

**GP\_CH3\_HSRC Bit Descriptions**

Bit	Name	Description
31:9	RSVD	<b>Reserved.</b>
8:0	LUT_INDEX	<b>LUT Index.</b> Used to initialize the LUT_INDEX pointer that is used for subsequent LUT operations. The LUT_INDEX automatically increments on a write to the GP_LUT_DATA register (GP Memory Offset 74h). When performing a read, bit 31 must be set to cause the hardware to perform the read and update the GP_LUT_DATA register. If this bit is not set, then a write is assumed and the read will not be performed.

**6.4.2.26 LUT Data (GP\_LUT\_DATA)**

GP Memory Offset 74h  
 Type R/W  
 Reset Value xxxxxxxxh

This register is used to store data into the LUT for indexed color translations and color patterns. The 32 bits written to this register are stored in the LUT at the location specified in the GP\_LUT\_INDEX register (GP Memory Offset 70h). A read of this register returns the contents of the LUT at the location specified by the GP\_LUT\_INDEX register. Either a read or write of this register will cause the GP\_LUT\_INDEX register to increment, so the LUT can be loaded through successive writes to the GP\_LUT\_DATA register.

**GP\_CH3\_HSRC Register Map**

31	30	29	28	27	26	25	24	23	22	21	20	19	18	17	16	15	14	13	12	11	10	9	8	7	6	5	4	3	2	1	0
LUT_DATA																															

**GP\_CH3\_HSRC Bit Descriptions**

Bit	Name	Description
31:0	LUT_DATA	<b>LUT_DATA.</b> Used to store data into the LUT for indexed color translations and color patterns.

**6.4.2.27 Interrupt Control (GP\_INT\_CNTRL)**

GP Memory Offset 78h

Type R/W

Reset Value 0000FFFFh

This register is used to control the interrupt signal from the GP. It contains a 16-bit mask and a 16-bit interrupt detect. The mask portion is read/write. A bit set in the mask register disables the corresponding interrupt bit. At reset, all interrupts are disabled. The interrupt detect bits are automatically set by the hardware to indicate that the corresponding condition has occurred and that the mask bit for that condition is not set. The interrupt detect bits remain set until they are cleared by a write to the GP\_INT\_CNTRL register. Writing a 1 to an interrupt detect bit clears the bit. Writing a 0 to an interrupt detect bit has no effect. Therefore, all of the interrupts in the GP may be cleared by reading the GP\_INT\_CNTRL register and writing back the value that was read. Whenever any of the interrupt detect bits are set in this register, the IN bit will be set in the GP\_BLT\_STATUS register (GP Memory Offset 44h[1]).

**GP\_INT\_CNTRL Register Map**

31	30	29	28	27	26	25	24	23	22	21	20	19	18	17	16	15	14	13	12	11	10	9	8	7	6	5	4	3	2	1	0
RSVD														I1	I0	RSVD											M1	M0			

**GP\_INT\_CNTRL Bit Descriptions**

Bit	Name	Description
31:18	RSVD	<b>Reserved.</b> Read returns 0.
17	I1	<b>GP Idle Detect Interrupt.</b>
16	I0	<b>Command Buffer Empty Detect Interrupt.</b>
15:2	RSVD	<b>Reserved.</b> Read returns 1.
1	M1	<b>GP Idle Mask Bit.</b>
0	M0	<b>Command Buffer Empty Mask Bit.</b>

## 6.5 Display Controller

The Display Controller (DC) module retrieves graphics, video, and overlay streams from the frame buffer, serializes the streams, performs any necessary color lookups and output formatting, and interfaces to the VP for driving the display device.

### Features

- 512x64-bit display FIFO
- 64x64x2-bit hardware cursor
- 64x vertical resolution x2-bit hardware icon overlay
- 3x261x8-bit palette/gamma RAM (including five extension colors)
- Display refresh compression
- 64x64-bit compressed line buffer
- Flexible timing generator
- Support for Video Blanking Interval (VBI) data
- Support for interlaced modes up to 1920x1080
- 3-tap flicker filter for support of interlaced NTSC and PAL display modes
- Flexible memory addressing
- Video overlay support

- Independent VGA block for complete hardware VGA implementation
- Dirty/Valid RAM and controller to monitor memory traffic in support of display refresh compression
- Six 512x64-bit line buffers to support downscaling and flicker filtering
- 3x5-tap graphics filter for scaling and filtering

The DC module consists of a GUI (Graphical User Interface) block, a VGA block, and back-end scaling/filter. The GUI is compatible with the Display Controller found in the GX processor. The VGA block provides hardware compatibility with the VGA graphics standard. The GUI and VGA blocks share a single display FIFO and display refresh memory interface to the memory controller. The VGA block passes 8-bpp and syncs to the GUI, which expands the pixels to 24-bpp via the CLUT (color lookup table). The VGA block also passes the information to the graphics filter for scaling and interlaced display support. This stream is then passed to the Video Processor (VP), which is used for video overlay. The VP forwards this information to the DAC (Digital-to-Analog Converter), which generates the analog red, green, and blue signals and buffers the sync signals, that are then sent to the display. The VP output can also be rendered as YUV data that can be output on the Video Output Port. The DC block diagram is shown in Figure 6-12.

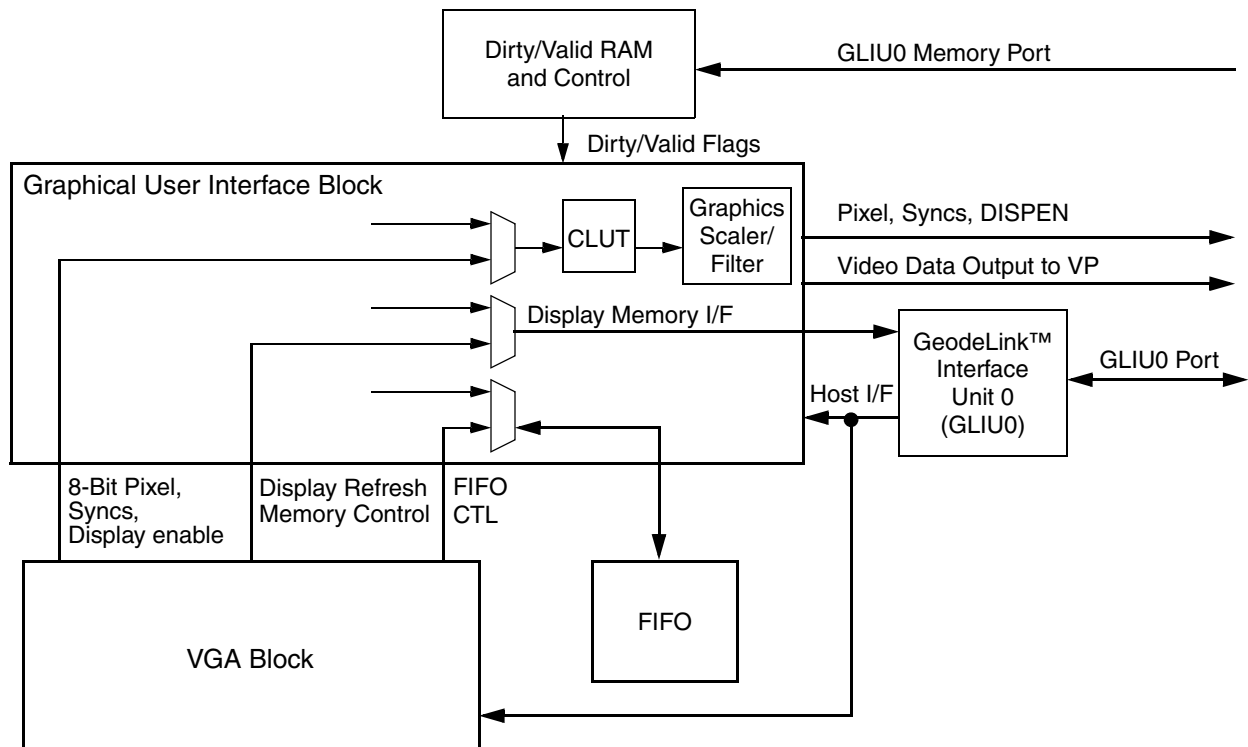


Figure 6-12. Display Controller High-Level Block Diagram

The GUI block, shown in Figure 6-13, provides sophisticated graphics functionality suitable for a GUI environment such as Windows® XP, Windows CE, or Linux® operating

systems. The GUI is optimized for high resolution and high color depth display modes.

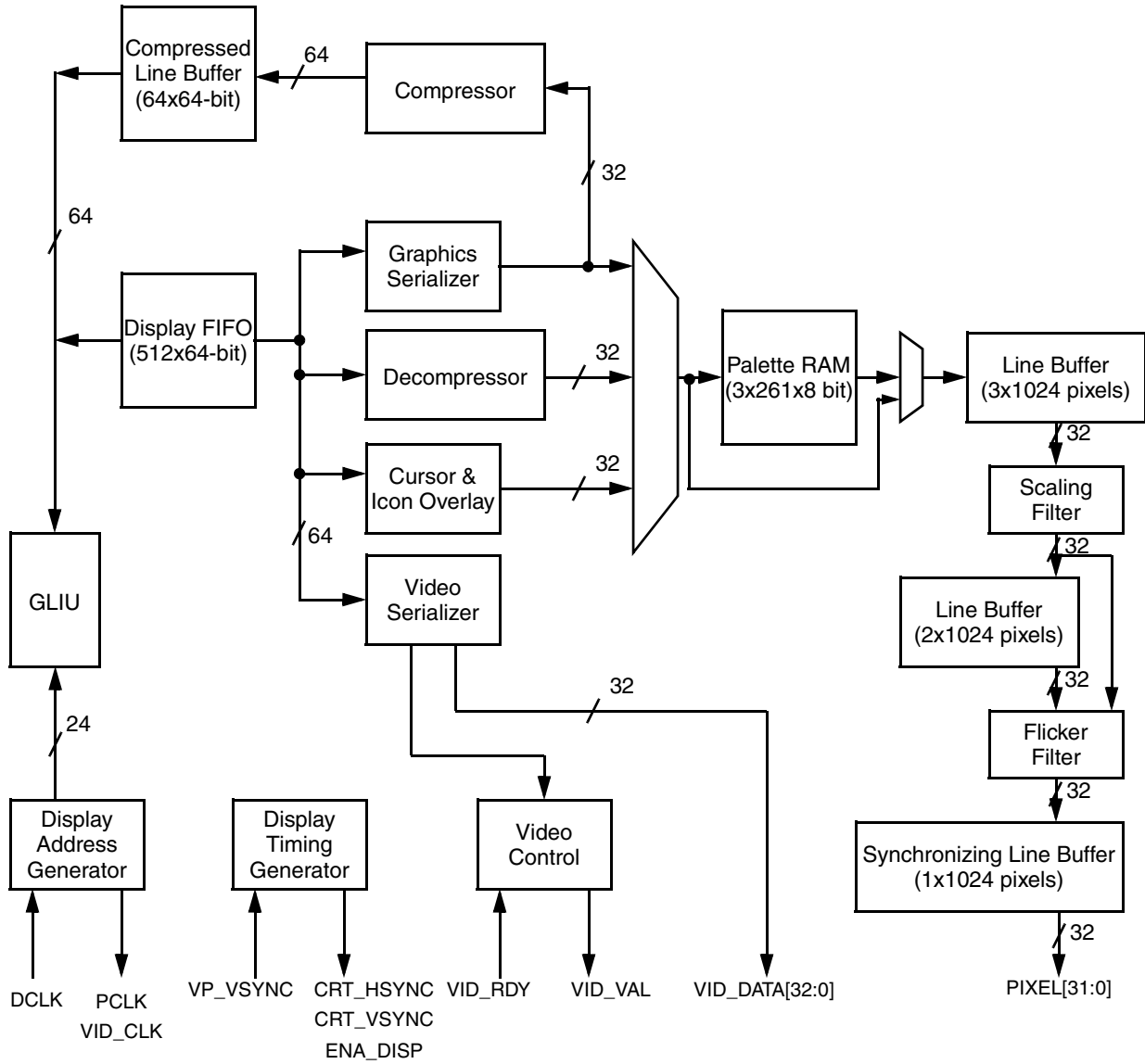


Figure 6-13. GUI Block Diagram

The VGA block, shown in Figure 6-14, provides hardware support for a compatible VGA solution. It consists of an independent CRT controller and pixel formatting units. It also provides the standard VGA host memory data manip-

ulation functions such as color compare, set, reset, etc. This block provides complete support for all VGA text and graphics modes.

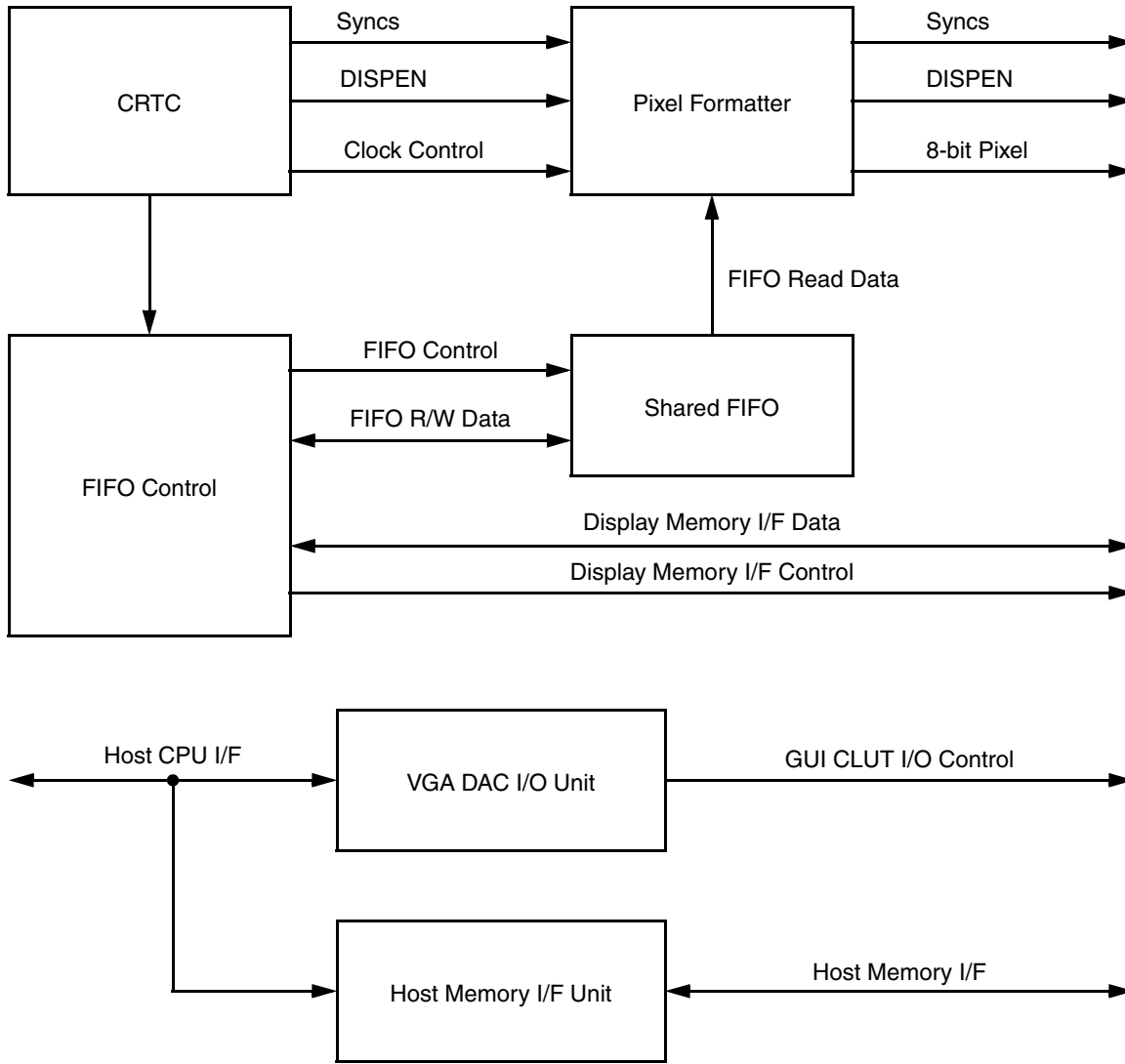


Figure 6-14. VGA Block Diagram



## 6.5.1 GUI Functional Overview

### 6.5.1.1 Display Mode Support

The display modes listed in Table 6-32 are supported by the GUI block. 32- and 24-bpp display support is provided across all resolutions. The Dot Clock source (DOTCLK) is provided by a PLL. Available memory bandwidth determines the resolutions and color depths that will function without display tearing. Memory controller configuration, GLIU frequency, and other demands on the memory controller set the available bandwidth. The GLIU frequency determines the memory controller frequency. Other demands on the memory controller such as the CPU and bus masters affect on available bandwidth are difficult to predict. Use of the video overlay feature additionally decreases the bandwidth available for screen refresh.

The Minimum GLIU Frequency criteria listed in Table 6-32 must be met for quality operation of the display. This frequency provides sufficient memory bandwidth for the memory controller to maintain reliable display refresh under all operating conditions, including the video overlay. As a general rule, Table 6-32 indicates what the minimum relationship of DOTCLK to GLIU frequency should be at the various color depths.

Bandwidth requirements for the VGA engine are not listed in this table. Most graphics modes require the same bandwidth as comparable 8-bpp display modes listed in Table 6-32. Text modes generally require higher bandwidth. Supported text modes require a GLIU clock frequency of 100 MHz or more to obtain the necessary memory bandwidth.

**Table 6-32. Display Modes**

Resolution	Color Depth (bpp)	Refresh Rate (Hz)	Dot Clock (MHz)	Min. GLIU Frequency (MHz)
640 x 480	8, 16, or 24/32	60	25.175	75
	8, 16, or 24/32	70	28.560	75
	8, 16, or 24/32	72	31.500	75
	8, 16, or 24/32	75	31.500	75
	8, 16, or 24/32	85	36.000	75
	8, 16, or 24/32	90	37.889	400
	8, 16, or 24/32	100	43.163	400
800 x 600	8, 16, or 24/32	60	40.000	75
	8, 16, or 24/32	70	45.720	75
	8, 16, or 24/32	72	49.500	75
	8, 16, or 24/32	75	49.500	75
	8, 16, or 24/32	85	56.250	75
	8, 16, or 24/32	90	60.065	400
	8, 16, or 24/32	100	68.179	400
1024 x 768	8, 16 or 24/32	60	65.000	75
	8, 16, or 24/32	70	75.000	100
	8, 16, or 24/32	72	78.750	100
	8, 16, or 24/32	75	78.750	100
	8, 16, or 24/32	85	94.500	100
	8, 16, or 24/32	90	100.187	400
	8, 16, or 24/32	100	113.310	400
1152x864	8, 16, or 24/32	60	81.600	100
	8, 16, or 24/32	70	97.520	100
	8, 16, or 24/32	72	101.420	200
	8, 16, or 24/32	75	108.000	200
	8, 16, or 24/32	85	119.650	200
	8, 16, or 24/32	90	129.600	400
	8, 16, or 24/32	100	144.000	400

Table 6-32. Display Modes (Continued)

Resolution	Color Depth (bpp)	Refresh Rate (Hz)	Dot Clock (MHz)	Min. GLIU Frequency (MHz)
1280 x 1024	8, 16, or 24/32	60	108.000	200
	8, 16, or 24/32	70	129.600	200
	8, 16, or 24/32	72	133.500	200
	8, 16, or 24/32	75	135.000	200
	8, 16, or 24/32	85	157.500	200
	8, 16, or 24/32	90	172.800	400
	8, 16, or 24/32	100	192.000	400
1600 x 1200	8, 16, or 24/32	60	162.000	200
	8, 16, or 24/32	70	189.000	200
	8, 16, or 24/32	72	198.000	233
	8, 16, or 24/32	75	202.500	233
	8, 16, or 24/32	85	229.500	266
	8, 16, or 24/32	90	251.182	400
	8, 16, or 24/32	100	280.640	400
1920x1440	8, 16, or 24/32	60	234.000	266
	8, 16, or 24/32	70	278.400	400
	8, 16, or 24/32	72	288.000	400
	8, 16, or 24/32	75	297.000	400
	8, 16, or 24/32	85	341.349	400
<b>Television Modes</b>				
720x483 SD NTSC	up to 32	59.94i	27.000	200
640x480 SD NTSC	up to 32	up to 60.00i	27.000	200
768x576 SD PAL	up to 32	50.00i	27.000	200
720x576 SD PAL	up to 32	50.00i	27.000	200
1280x720 HD	up to 32	up to 60.00i	up to 74.750	200
1280x768 HD	up to 32	50.00i	74.750	200
1440x720 HD	up to 32	60.00i	74.750	400
1440x768 HD	up to 32	50.00i	74.750	400
1920x1080 HD	up to 32	up to 60.00i	up to 148.500	400

### 6.5.1.2 Display FIFO

The DC module incorporates a 512-entry x 64-bit display FIFO that queues up all display data, including graphics frame buffer data, compressed display buffer data, cursor and icon overlay data, and video overlay YUV data. When the video output port is enabled, 32 slots of the display FIFO are allocated for the video transfer buffer.

The DFHPSL and DFHPEL (DC Memory Offset 004h[11:8] and [15:12]) bits are used to set the thresholds for high-priority memory request assertion. These levels can be tuned for a particular display mode to optimize memory bandwidth utilization.

### 6.5.1.3 Hardware Cursor and Icon Overlays

The GUI supports a 64x64x2-bit hardware cursor overlay. The 2-bit codes are defined in Table 6-33.

A hardware icon overlay is also supported for applications that require a fixed sprite overlay. This is particularly useful in portable applications for display status indicators that are independent of the application that is running. When enabled, the icon overlay is displayed on each active scan line. The icon is 64 pixels wide and supports three colors plus transparency as shown in Table 6-34.

The display of cursor and icon overlays is controlled by CURE (bit 1) and CLR\_CUR (bit 2) in DC\_GENERAL\_CFG (DC Memory Offset 004h), which take effect on the next vertical sync after the bits are programmed. The cursor is always displayed on top of the icon if both are enabled.

The cursor and icon are inserted into the graphics stream prior to mixing the video overlay data. Since the background color-keyed value generally does not match the cursor or icon colors, the cursor and icon may be displayed on top of any active video. Note that the cursor and icon features are not available in VGA modes.

**Table 6-33. Cursor Display Encodings**

AND Mask	XOR Mask	Color Displayed
0	0	Cursor Color 0 - Palette Index 100h
0	1	Cursor Color 1 - Palette Index 101h
1	0	Transparent - Background Pixel
1	1	Inverted - Bitwise Inversion of Background Pixel

**Table 6-34. Icon Display Encodings**

AND Mask	XOR Mask	Color Displayed
0	0	Icon Color 0 - Palette Index 102h
0	1	Icon Color 1 - Palette Index 103h
1	0	Transparent - Background Pixel
1	1	Border Color - Palette Index 104h

**Cursor/Icon Buffer Formats**

In 2-bpp mode, the cursor buffer is stored as a linear display buffer containing interlaced AND and XOR QWORDS (8-byte segments). Each QWORD contains the appropriate mask for 64 pixels. Even QWORDS contain the AND masks and odd QWORDS contain the XOR masks. The masks are stored “in display order” with the leftmost pixel being most significant and the rightmost pixel being least significant.

For 32-bpp cursors, the cursor pixels include an alpha value, and are alpha blended with the underlying graphics pixels. For the purposes of cursor overlay, the cursor alpha value is used. If the graphics stream includes an alpha value, that value is not used for the purposes of cursor overlay. However, the graphics alpha value is retained in the resulting pixel stream.

The cursor buffer stores 192 bytes of data per scan line (for 48 horizontal pixels) in 32-bpp mode. In this mode, the cursor size is 48 pixels wide and 64 pixels high, and so the buffer is 12 KB in size.

In 2-bpp mode, cursor buffer includes 16 bytes of data per scan line (for 64 horizontal pixels). The cursor is 64x64, therefore the cursor buffer is 1 KB in size.

The DC contains logic to address the overlay of the cursor on top of a color key region. Table 6-35 indicates what pixel value is output from the DC’s rendering engine when the cursor is overlaid on the color key region.

Note that this behavior varies slightly when the graphics are represented in 32-bpp mode, which includes a per-pixel alpha value.

**Table 6-35. Cursor/Color Key/Alpha Interaction**

Cursor	Per-Pixel Alpha	Color Key Match, Per-Pixel Alpha	No Per-Pixel Alpha	Color Key Match, No Per-Pixel Alpha
No Cursor	COLOR = graphics color ALPHA = graphics alpha	COLOR = graphics color ALPHA = 00	COLOR = graphics color ALPHA = FF	COLOR = graphics color ALPHA = 00
2-bpp Cursor (cursor color)	COLOR = cursor color ALPHA = graphics alpha or FF (configurable)	COLOR = cursor color ALPHA = FF	COLOR = cursor color ALPHA = FF	COLOR = cursor color ALPHA = FF
2-bpp Cursor (invert color)	COLOR = invert graphics color ALPHA = graphics alpha or FF (configurable)	COLOR = invert graphics color ALPHA = FF	COLOR = invert graphics color ALPHA = FF	COLOR = invert graphics color ALPHA = FF
2-bpp Cursor (transparent)	COLOR = graphics color ALPHA = graphics alpha	COLOR = graphics color ALPHA = 00	COLOR = graphics color ALPHA = FF	COLOR = graphics color ALPHA = 00
Color Cursor (with alpha)	COLOR = blend cursor/graphics ALPHA = pp alpha or FF (configurable)	COLOR = cursor color ALPHA = cursor alpha	COLOR = blend cursor/graphics ALPHA = FF	COLOR = cursor color ALPHA = cursor alpha

#### 6.5.1.4 Display Refresh Compression

To reduce the system memory contention caused by the display refresh, the GUI block contains compression and decompression logic for compressing the frame buffer image in real time as it is sent to the display. The DC does not modify the standard frame buffer, but rather, it utilizes a separate compressed display buffer for updating the display under certain conditions. This compressed display buffer can be allocated within the extra off-screen memory within the graphics memory region.

Coherency of the compressed display buffer is maintained by use of dirty and valid bits for each line. Whenever a line has been successfully compressed, it is retrieved from the compressed display buffer for all future accesses until the line becomes dirty again. Dirty lines are retrieved from the normal uncompressed frame buffer.

The compression logic has the ability to insert a “static” frame every other display frame, during which time dirty bits are ignored and the valid bits are read to determine whether a line should be retrieved from the frame buffer or compressed display buffer. This allows a latency of one frame between pixels actually being rendered and showing up on the display. This effect typically goes unnoticed for traditional 2D applications but may result in increased tearing in single-buffered animation sequences. This feature may be used to tune for maximum performance or optimal display quality.

The compression algorithm used commonly achieves compression ratios between 10:1 and 50:1, depending on the nature of the display data. The compression algorithm employed is lossless and therefore results in no loss of visual quality. This high level of compression provides higher system performance by reducing typical latency for normal system memory access, higher graphics performance by increasing available drawing bandwidth to the memory subsystem, and lower power consumption by significantly reducing the number of off-chip memory accesses required for refreshing the display. These advantages become more pronounced as display resolution, color depth, and refresh rate are increased, and as the size of the installed DRAM increases.

As uncompressed lines are fed to the display, they are compressed and stored in an on-chip compressed line buffer (64x64 bits). Lines will not be written back to the compressed display buffer in the DRAM unless a successful compression has resulted, so there is no penalty for pathological frame buffer images where the compression algorithm is sub-optimal.

#### 6.5.1.5 Dirty/Valid RAM

The DC module incorporates the Dirty/Valid RAM (DVRAM) in the Display Controller module. The Dirty/Valid RAM controller directly snoops GLIU0 request packets on the memory data port.

The Dirty/Valid RAM may be used to monitor locations in memory other than the frame buffer. (Compression and decompression must be disabled in order for the Display Controller to continue to function properly.) This may be used for scenarios where software (or the Graphics Processor) must modify or re-render a frame whenever corresponding modifications occur in an offscreen graphics buffer. The “palletized” bit is set upon writes to the corresponding region of memory. However, it is up to software to clear the dirty bit by writing to the Dirty/Valid RAM Access register (DC Memory Offset 08Ch).

#### 6.5.1.6 Palette/Gamma RAM

The GUI block contains a 261x24 color lookup table RAM used for palletized display modes (Indexes 0-255), cursor colors (Indexes 256-257), and the GUI mode border color (Index 260). This color lookup table is also used by the VGA block to map the 8-bit VGA pixels to a 24-bit RGB color value. In true color display modes (16, 24, or 32-bpp), the color lookup table can be used as a gamma correction RAM.

#### 6.5.1.7 Display Address Generator

The GUI block supports flexible address generation for the frame buffer, compressed display buffer, cursor and icon buffers, and video buffers (YUV 4:2:2 or 4:2:0 format). A separate start offset register is provided for each display buffer. The start offset may be programmed to be relative to frame buffer space (up to 256 MB).

#### 6.5.1.8 Display Timing Generator

The GUI block includes a flexible timing generator capable of handling up to a 1920x1440 resolution display. Horizontal timings are programmable with 1-pixel granularity. Vertical timings are programmable with scan line granularity. The timing registers are master-slaved such that a new timing set may be programmed while the working set is still active. The TRUP configuration bit (DC\_DISPLAY\_CFG, DC Memory Offset 008h[6]) is used to allow the new set of timings to take effect at the start of vertical sync. As long as the horizontal and vertical total counts do not change when a new timing set is loaded, the sync pulses should remain stable and the display should not glitch.

### 6.5.1.9 Video Overlay Support

The GUI block also supports a video overlay function. The DC has flexible addressing capability for YUV 4:2:2 and YUV 4:2:0 display surfaces. Video data is stored in a separate buffer within the off-screen frame buffer. Independent surface pitch control is provided for Y and U/V.

The DC fetches the contents of the video and transmits it to the Video Processor once per frame.

The Video Processor provides enhanced overlay scaling and filtering options.

The width of the video output port is 32 bits. This allows the display of high-resolution video source material (up to 1920 horizontal pixels) mixed with high-resolution graphics data.

Table 6-36 illustrates the minimum video port bandwidth required for a number of different graphics display resolutions.

**Table 6-36. Video Bandwidth**

Resolution	Refresh Rate (Hz)	Line Rate (KHz)	Video Source Size (B)	Video Port Bandwidth Required (MB/s)
640x480	60	31.5	1440	45.4
			2160	68.0
	85	43.3	1440	62.4
			2160	93.5
800x600	60	37.9	1440	54.5
			2160	81.9
	85	53.7	1440	77.3
			2160	116.0
1024x768	60	48.4	1440	69.7
			2160	105
	85	68.7	1440	98.9
			2160	148.4
1280x1024	60	64.0	1440	92.2
			2160	138
	85	91.1	1440	131
			2160	197
1600x1200	60	75.0	1440	108
			2160	162
	70	87.5	1440	126
			2160	189

### 6.5.1.10 Output Formats

#### Video Output Data Sequencing

The order that video data is transmitted from the DC to the VP depends on the format of the video data. For YUV 4:2:0 mode, the entire stream of Y data is transmitted for a source line, followed by the entire stream of U data for the line, and finally, the entire stream of V data for the line. The size of the U and V streams are always one-half the size of the Y stream. The data is not interlaced as in the YUV 4:2:2 mode. The data ordering is shown in Table 6-37.

**Table 6-37. YUV 4:2:0 Video Data Ordering**

Sequence	Data Type	Max Size (Bytes)
1	Y stream	1920
2	U stream	960
3	V stream	960

For YUV 4:2:2 mode, YUV data is interlaced in a single stream, with a maximum size of 1440 bytes.

In YUV 4:2:2 mode, four orders of YUV data are supported. The data format is selectable via the Video Configuration register (VP Memory Offset 000h) in the Video Processor module. The data ordering is shown in Table 6-38.

**Table 6-38. YUV 4:2:2 Video Data Ordering**

Mode	YUV Ordering (Note 1)
0	U Y0 V Y1
1	Y1 V Y0 U
2	Y0 U Y1 V
3	Y0 V Y1 U

Note 1. U = Cb, V = Cr.

### 6.5.2 VBI Data

VBI (Video Blanking Interval) data is fetched by the DC at the start of each frame. The data is fetched from a buffer in memory, separately from video or graphics data. It is presented to the VP on the graphics port. VBI data is provided via a path that circumvents the gamma correction palette and the graphics filter. The data presented to the VP/VOP is only the data in memory. There are no additional headers attached by the DC. Configuration registers in the DC determine how many lines of VBI data are sent during each field; the lines can be enabled/disabled independently of one another. If a line is disabled, no data is fetched (from memory) for that line, and the memory line pointer is NOT incremented. Thus, non-contiguous lines of screen VBI must be stored contiguously in memory if there are no active VBI lines between them. The DC can be programmed to fetch multiple fields worth of VBI data from linear frame buffer space without resetting to the start of the buffer on each field. This minimizes the interrupt overhead required to manage VBI data. VBI data streams of up to 4 KB per scan line are supported.

The VBI horizontal timings are controlled in a manner similar to the horizontal active timings. The reference point for the horizontal (pixel) counter is the start of active video. This means that if the VBI data is to be active before this point on the line (i.e., to the left of, and above active video), it may be necessary to set the VBI horizontal start point to a large number (less than the horizontal total, but larger than the VBI horizontal end point). The line counter used to calculate VBI offsets is incremented at the start of each HSYNC, and NOT at the start of active video. This means that even if the VBI horizontal timings are such that it starts during the horizontal “back porch” region, the line counts and enables are the same as if the VBI horizontal timing was the same as the graphics timing.

### 6.5.3 GenLock

The DC has the ability to use an external source to determine the timing and frequency of VSYNC. This is primarily used in systems in which the VIP is providing video data to be displayed in a native screen resolution and frame rate. The DC can also be configured to detect the loss of VSYNC in this case, and temporarily generate its own VSYNC pulse until the external source resumes generation of video data and synchronization. This is accomplished through the use of a VSYNC timeout counter. The DC can also generate an interrupt when a loss of synchronization is detected.

**6.5.4 VGA Block Functional Overview**

The VGA block provides full hardware support for a VGA graphics subsystem. It is compatible with the IBM VGA as defined in the IBM Video Subsystem Technical Reference manual. This section provides an overview of VGA features and functions.

**6.5.4.1 VGA Modes**

A VGA “mode” is a programmed VGA configuration defined by the VGA BIOS that produces a graphics frame buffer format and a screen image with specific characteristics. The base VGA function provides coded text modes for text-based applications, and graphics modes for graphics-based applications. Many of these modes are compatible with older graphics adapter standards, such as monochrome display adapter, color graphics adapter, and enhanced graphics adapter.

**Text Modes**

There are five text modes defined by VGA BIOS as shown Table 6-39.

Each of the text modes provides a coded frame buffer consisting of a 16-bit value for each character. The low byte is the ASCII character code for the character to display, and the high byte is an attribute byte that determines how the character is displayed (foreground, background colors, blink, underline, etc.). There are two formats defined by BIOS for the attribute byte: color and monochrome as shown in Table 6-40.

**Graphics Modes**

The graphics modes defined by VGA BIOS are shown in Table 6-41.

**Table 6-39. VGA Text Modes**

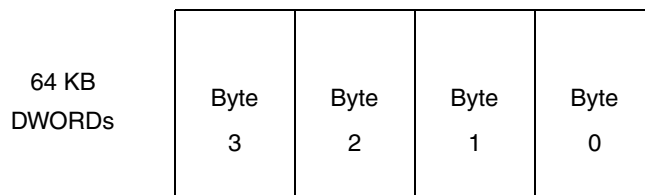
BIOS Mode #	Screen Size in Characters	Attribute Type	Buffer Address	Compatibility
0, 1	40 x 25	Color	B8000h-BFFFFh	CGA
2, 3	80 x 25	Color	B8000h-BFFFFh	EGA, VGA
7	80 x 25	Monochrome	B0000h-B7FFFh	MDA

**Table 6-40. Text Mode Attribute Byte Format**

Bit	Color Definition	Monochrome Definition
7	Blink	Blink
6	Background Color (R)	Background
5	Background Color (G)	Background
4	Background Color (B)	Background
3	Foreground Intensity/Font Select	Foreground Intensity/Font Select
2	Foreground Color (R)	Foreground
1	Foreground Color (G)	Foreground

**Table 6-41. VGA Graphics Modes**

BIOS Mode #	Screen Size in Pixels	# of Colors	Frame Buffer Format	Buffer Address
4, 5	320 x 200	4	Packed Pixel	B8000h-BFFFFh
6	640 x 200	2	Packed Pixel	B8000h-BFFFFh
0xD	320 x 200	16	Planar	A0000h-AFFFFh
0xE	640 x 200	16	Planar	A0000h-AFFFFh
0xF	640 x 400	4	Planar	A0000h-AFFFFh
0x10	640 x 350	16	Planar	A0000h-AFFFFh
0x11	640 x 480	2	Planar	A0000h-AFFFFh
0x12	640 x 480	16	Planar	A0000h-AFFFFh
0x13	320 x 200	256	Packed Pixel	A0000h-AFFFFh



**Figure 6-15. VGA Frame Buffer Organization**



### 6.5.5.2 Graphics Controller

The graphics controller manages the CPU interaction with video memory, and contains the video serializers that feed the front end of the attribute controller. Several memory

read and write modes are supported that provide various forms of acceleration for VGA graphics operations. A high-level diagram of the graphics controller is shown in Figure 6-16.

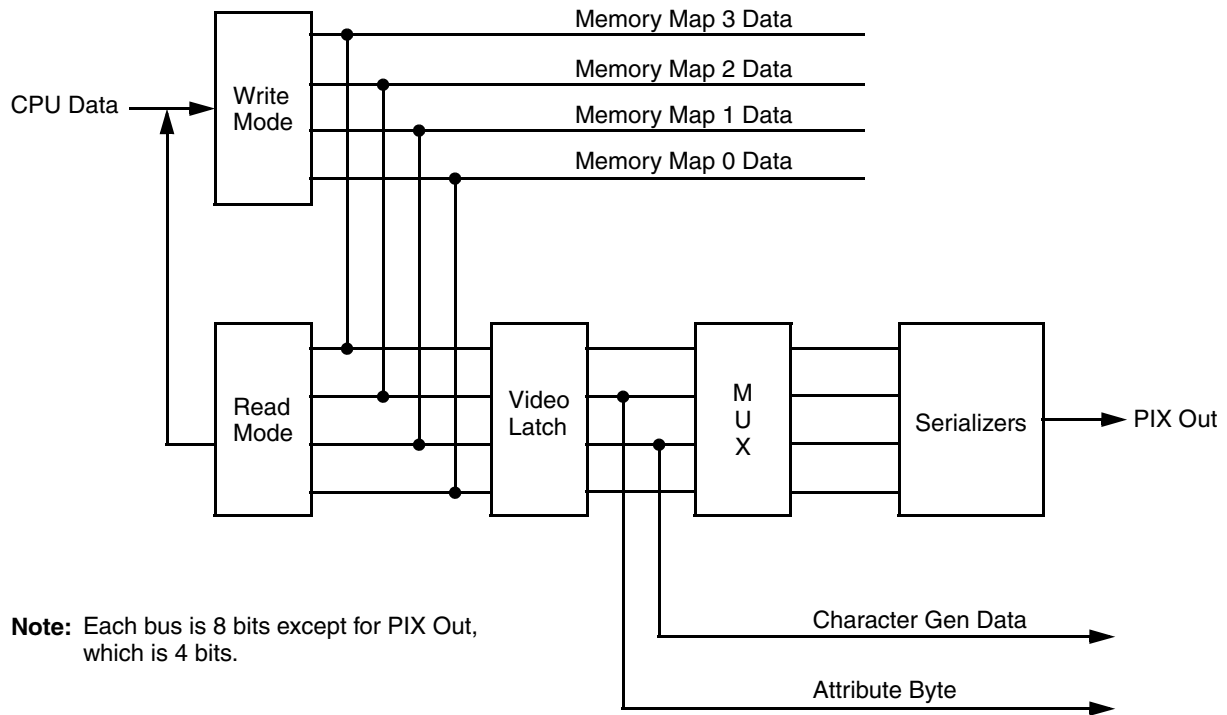
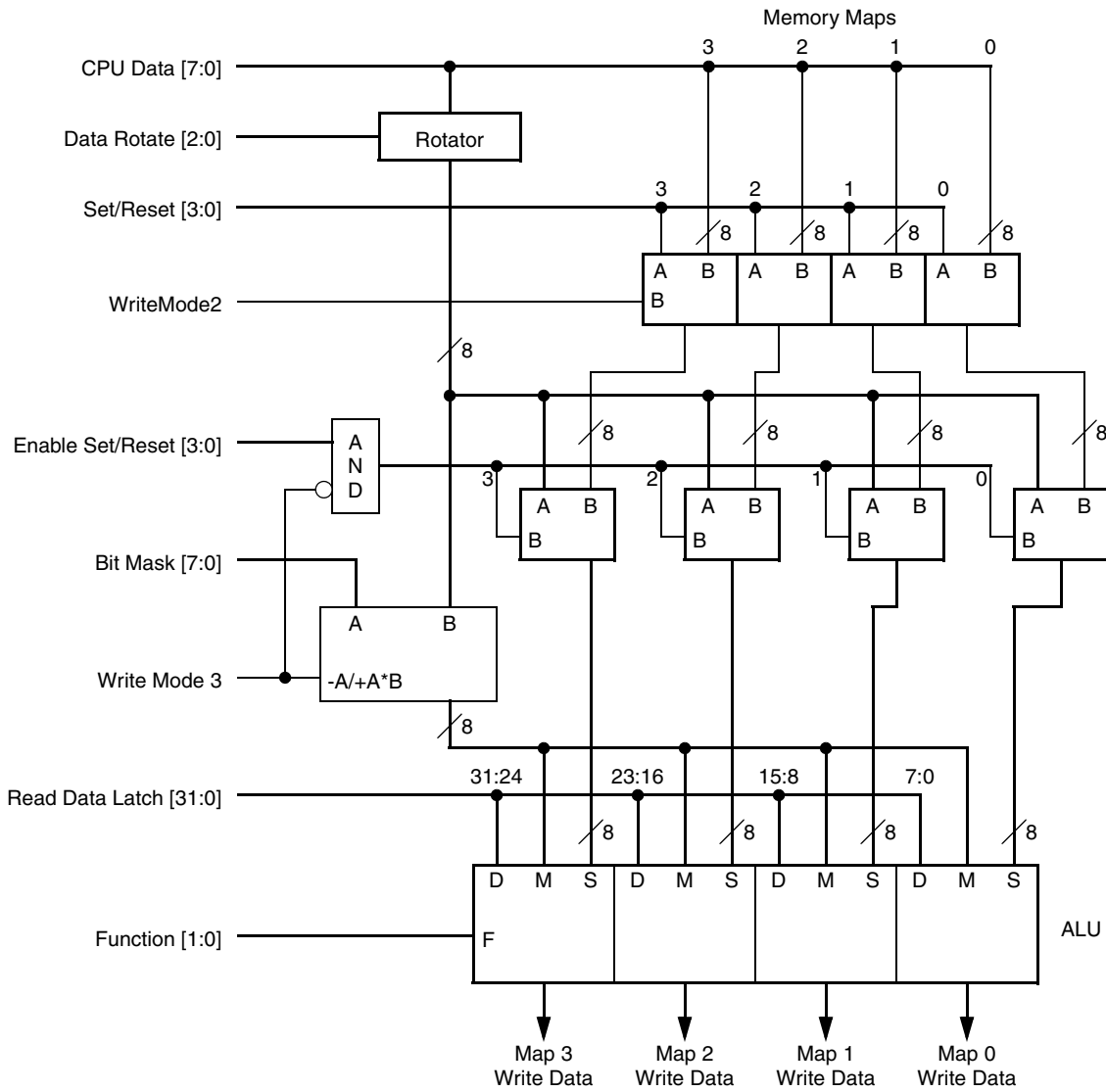


Figure 6-16. Graphics Controller High-level Diagram

**6.5.5.3 Write Modes**

There are four write modes supported by the graphics controller (mode 0, 1, 2, and 3). These write modes provide

assistance to the CPU when the frame buffer is in a planar graphics format. Figure 6-17 shows the data flow logic that supports these modes.



**Figure 6-17. Write Mode Data Flow**

### 6.5.5.4 Read Modes

There are two read modes provided to assist the CPU with graphics operations in planar modes. Read mode 0 simply returns the frame buffer data. Read mode 1 allows the CPU

to do a single color compare across eight pixels. Figure 6-18 shows the data flow for read modes. Figure 6-19 on page 292 shows how the color compare logic in Figure 6-18 works.

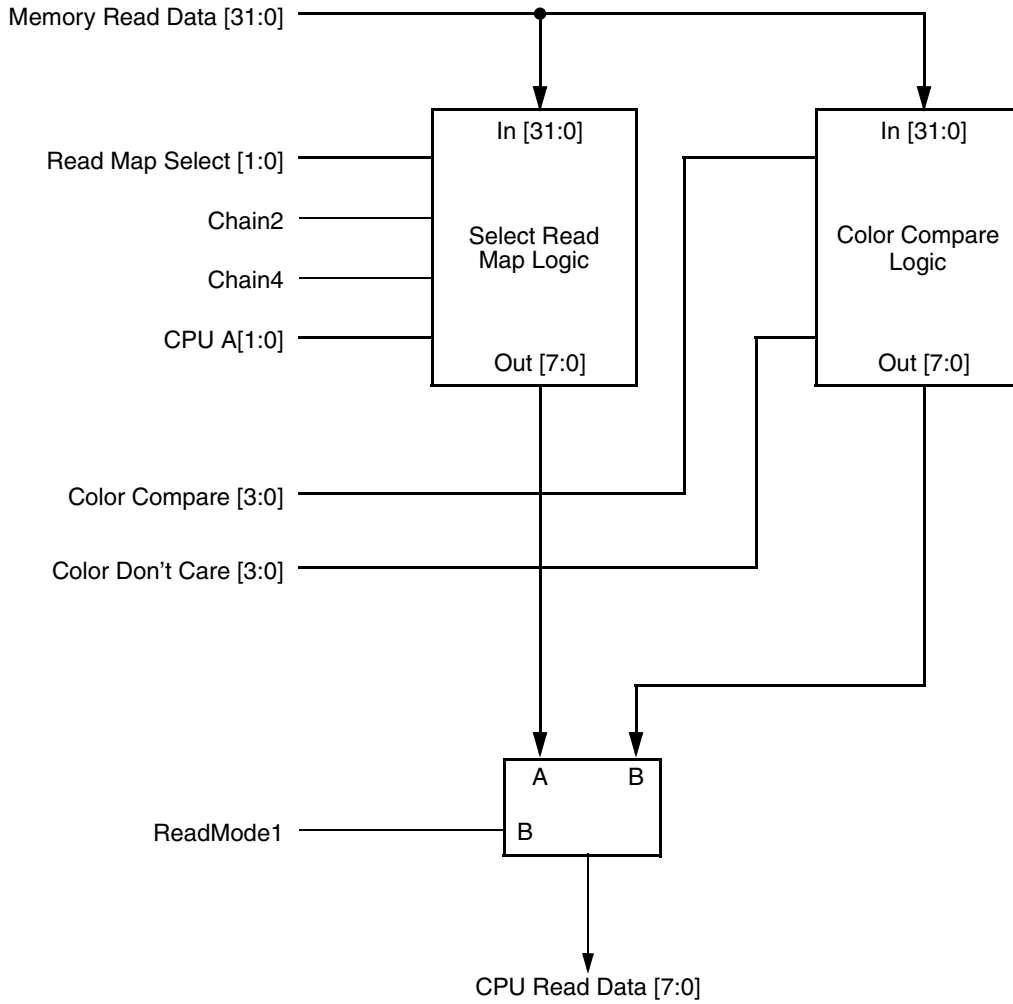


Figure 6-18. Read Mode Data Flow

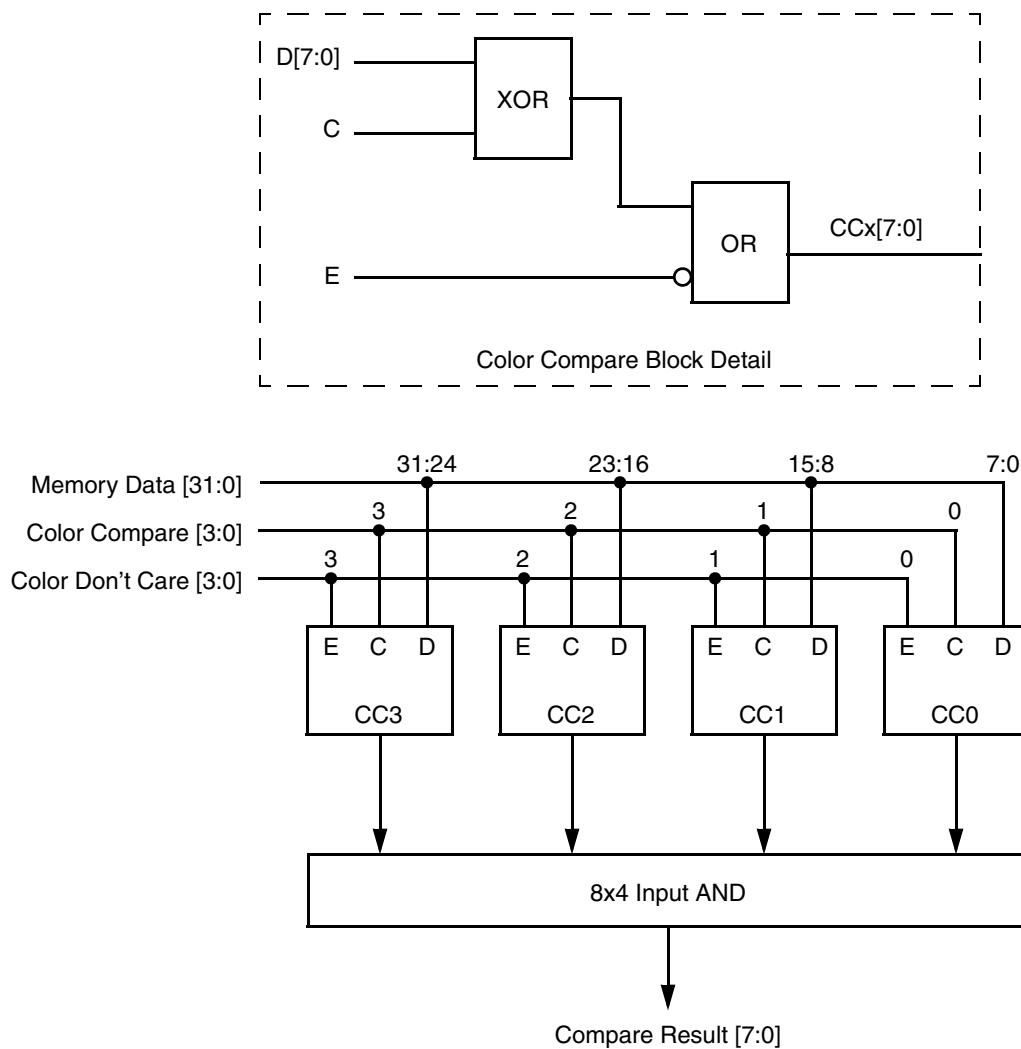


Figure 6-19. Color Compare Operation

### 6.5.6 Graphics Scaler/Filter

The DC incorporates a 3x5 tap filter to be used for up/downscaling of the graphics image. In order to support the filter, three lines of buffering are also included. These three line buffers support a frame buffer resolution of up to 1024 pixels wide. For wider images, the buffers are automatically reconfigured into one line, and scaling is not supported. For frame buffer images up to and including 1024 pixels in width, vertical downscaling of up to (but not including) 2:1 is supported and horizontal downscaling of up to (but not including) 2:1 is supported.

The filter is organized as five 3-tap vertical filters that feed the five taps of a horizontal filter. The filter supports 1/256 inter-pixel quantization (i.e., 256-phase) in both the horizontal and vertical directions. The filter coefficients are 10 bits wide.

Scaling is controlled by adjusting the horizontal and vertical filter scale factors (through configuration register 90). These numbers represent binary rational numbers in a 2.14 format. At the start of each frame, the H Phase Adder and V Phase Adder are reset to 0. At the start of each scan line, the V Phase adder is added to V Phase and the result is stored in V Phase Adder. The integer portion of the value in V Phase Adder indicates on which line the filter kernel is centered. The most significant eight bits of the fractional portion of this value determine the vertical phase for the purpose of determining the filter coefficients.

The H Phase Adder mechanism is similar but operates on pixels instead of lines.

A block diagram of the filter is shown in Figure 6-20.

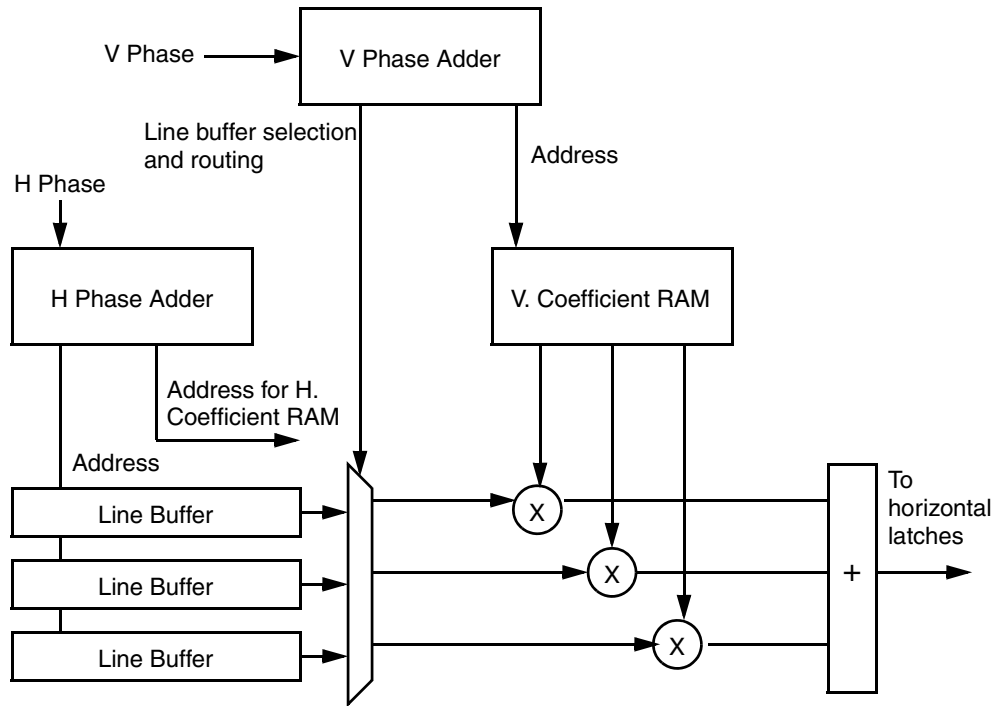


Figure 6-20. Graphics Filter Block Diagram

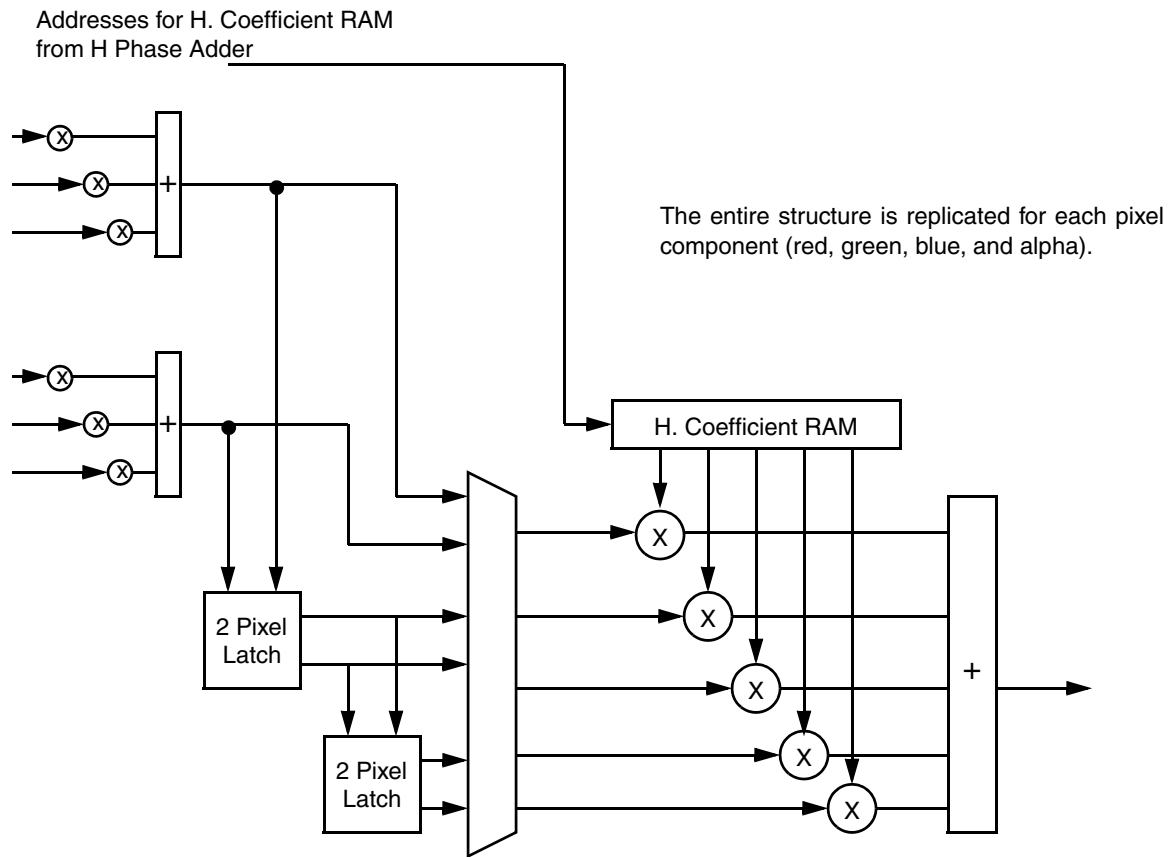
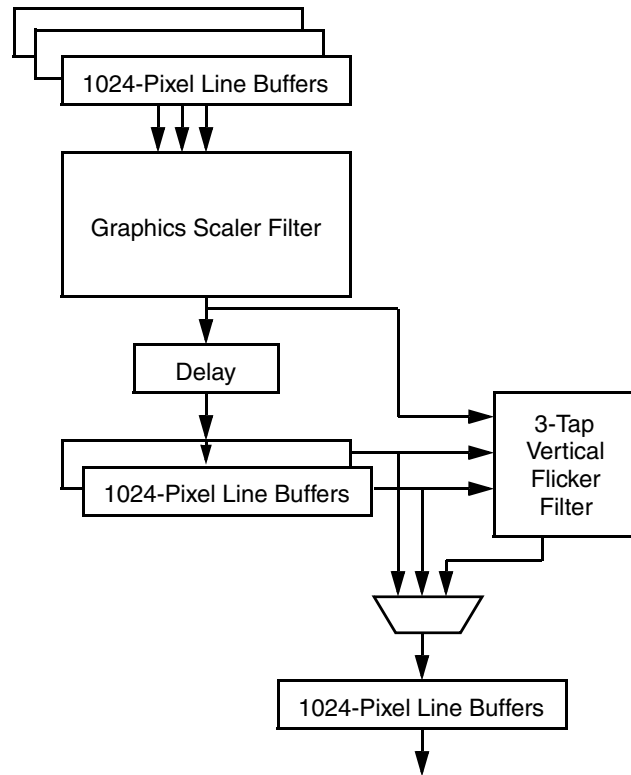


Figure 6-20. Graphics Filter Block Diagram (Continued)

To support the flicker filter, the scaling filter then feeds two additional line buffers. These buffers are 1024 pixels wide. The scaling filter directly feeds a tap of the 3x1-tap flicker filter. (The other two taps are fed by the two line buffers.) All filtering is performed in the GeodeLink I/F clock domain. The result from the flicker filter feeds a final line buffer, which is used to synchronize the data stream to the Dot clock domain. When the flicker filter is enabled, the final

image width is dictated by this final line buffer, which is 1024 pixels wide. When the flicker filter is disabled, the two line buffers normally used to feed the flicker filter are used as one line buffer, that feeds the final synchronizing line buffer. This enables scaling to image sizes up to 2048 pixels wide, provided that interlacing is not required. Figure 6-21 illustrates the flicker filter and line buffer path.



**Figure 6-21. Flicker Filter and Line Buffer Path**

### 6.5.7 Color Key Elimination

Additional logic, not shown in the diagrams, is used to preserve the color key color. This logic, when enabled, adjusts the alpha value for each filter input pixel in which a color key match is detected. The filter then uses the alpha value to determine if a pixel matches the color key. For information on the interaction of cursor and color key, Table 6-35 on page 284.

The filter contains specialized logic to remove color key pixels from the blended output and replace them with nearby pixels. This prevents halo effects if the color key contrasts sharply with the surrounding graphics image.

For each of the 3-tap vertical filters, except the center one, the replacement algorithm is as follows:

- If the top pixel is the only color key pixel, the center pixel is used in its place.
- If the bottom pixel is the only color key pixel, the center pixel is used in its place.
- If the center pixel is the only color key pixel, the top pixel is used in its place.
- If any two pixels are color key pixels, the remaining pixel is output to the horizontal filter.
- If all pixels are color key pixels, the bottom pixel is output to the horizontal filter. (The vertical output is a color key pixel and the alpha value is set accordingly.)

For the center 3-tap vertical filter, the algorithm is as follows:

- If the top pixel is a color key pixel, the center pixel is used in its place.
- If the bottom pixel is a color key pixel, the center pixel is used in its place.
- If the center pixel is a color key pixel, the center pixel is output to the horizontal filter regardless of the values of the other two pixels. (The vertical output is a color key pixel, and the alpha value is set accordingly.)

The horizontal filter algorithm follows. Assume that the pixel inputs are numbered 1-5, left to right.

- If pixel 1 is a color key pixel and pixel 2 is not, pixel 2 is used in place of pixel 1.
- If pixel 1 and pixel 2 are both color key pixels, pixel 3 is used in place of pixel 1.
- If pixel 2 is a color key pixel, pixel 3 is used in place of pixel 2.
- If pixel 5 is a color key pixel and pixel 4 is not, pixel 4 is used in place of pixel 5.
- If pixel 4 and pixel 5 are both color key pixels, pixel 3 is used in place of pixel 5.
- If pixel 4 is a color key pixel, pixel 3 is used in place of pixel 4.

- If pixel 3 is a color key pixel, pixel 3 is output from the filter regardless of the values of pixels 1, 2, 4, and 5. (The result is a color key pixel; the alpha value is set accordingly.)

If the center pixel matches the color key, it is passed through directly. If the center pixel does not match the color key, then any other filter input pixel that matches the color key is discarded and replaced by a nearby non-color-key-matching neighbor.

### 6.5.8 Using the Graphics Filter

From a software perspective, the AMD Geode LX processor DC appears much like its predecessor in the AMD Geode GX processor design. The graphics filter is disabled by default, and the timing and addressing registers operate as before. One significant change is the addition of color key detection logic to the DC block. This logic was previously only in the VP.

When enabling the VP for the purpose of scaling the output image, some additional parameters must be programmed (These parameters need not be programmed if the graphics filter/scaler is to remain disabled.):

- The horizontal and vertical size of the source image
- The horizontal and vertical scaling factors to be used to scale the source image
- The filter coefficients

The timing registers (DC Memory Offsets 040h-058h) should be programmed based on the parameters for the resulting output image. Note that this image may differ in size from the frame buffer image. The frame buffer image size is used to determine the value to be written to the Frame Buffer Active Region Register (DC Memory Offset 05Ch).

The scaling factors are programmed into the Graphics Filter Scale Register (DC Memory Offset 090h). These fields are 16 bits each (horizontal and vertical). The 16 bits represent the ratio of the destination image size to the source image size. They are right-shifted 14 bits to represent fractional values between 0 and 3.99993896484375. However, due to hardware limitations, the downscale factors cannot exceed 2.0. Thus the image can be downscaled by nearly 2X in the horizontal and vertical directions. The image can be upsampled by up to 16384X, although the CRTC does not support images beyond 1920x1440 pixels, so it is unlikely that scale factors beyond about 4X would ever be used.

VBI data is not filtered. The scaling factors in the Graphics Filter Scale register have no effect on VBI data.

The filter supports 256 sub-pixel phases in both the horizontal and vertical directions. Each coefficient is 10 bits, and is represented as a 2's complement number, right-shifted 9 bits to represent values between -1 and 0.998046875. The coefficients must be loaded into the RAMs by software, using the IRQ/Filter Control register, Filter Coefficient Data register 1, and Filter Coefficient Data Register 2 (DC Memory Offsets 094h-09Ch).



### 6.5.9 Interlaced Modes

For interlaced modes, the V\_ACTIVE and V\_TOTAL fields are configured for the odd field. The Even Field Vertical Timing registers (DC Memory Offsets 0E4h-0ECh) are configured for the corresponding even field. Figure 6-22 on page 298 shows a representative timing diagram for the odd and even timing register settings in interlaced modes, and Table 6-43 on page 298 presents the (decimal) timing values for some common interlaced modes.

The DC is capable of producing an interlaced output using any of three separate mechanisms. It can fetch the graphics data in an interlaced manner, flicker filter the graphics data, or use the same graphics data for both odd and even

fields, (which would effectively line-double the resulting image). When the VGA is being used, interlaced addressing is not supported, and scaling must be used. When the frame buffer source image or the output image is wider than 1024 active pixels, the flicker filter is not supported.

When scaling and/or interleaving is enabled, the size of the frame buffer image (in pixels) will vary from the size of the output image. Table 6-42 and Table 6-44 on page 299 indicates how the DC's timing register fields should be programmed for supported scaling and interlacing modes. (Note that for VGA modes, there are several VGA registers that can affect the size of the frame buffer image. These registers are not enumerated in the table.)

**Table 6-42. Programming Image Sizes**

Mode	Pre-scale Horizontal Width	Pre-scale Height	Post-scaler Width	Post-scaler Height	Final (Output) Width	Final (Output) Height
Default (no VGA, scaling, interlacing, or flicker filter)	H_ACTIVE	V_ACTIVE	H_ACTIVE	V_ACTIVE	H_ACTIVE	V_ACTIVE
Scaling only	FB_H_ACTIVE	FB_V_ACTIVE	H_ACTIVE	V_ACTIVE	H_ACTIVE	V_ACTIVE
Interlacing only (no flicker filter)	H_ACTIVE	V_ACTIVE or V_ACTIVE_EVEN (alternating)	H_ACTIVE	V_ACTIVE or V_ACTIVE_EVEN (alternating)	H_ACTIVE	V_ACTIVE or V_ACTIVE_EVEN (alternating)
Interlacing with flicker filter	H_ACTIVE	V_ACTIVE + V_ACTIVE_EVEN + 1 (Note 1)	H_ACTIVE	V_ACTIVE + V_ACTIVE_EVEN + 11	H_ACTIVE	V_ACTIVE or V_ACTIVE_EVEN (alternating)
Interlacing with interlaced addressing (no flicker filter)	H_ACTIVE	V_ACTIVE or V_ACTIVE_EVEN (alternating)	H_ACTIVE	V_ACTIVE or V_ACTIVE_EVEN (alternating)	H_ACTIVE	V_ACTIVE or V_ACTIVE_EVEN (alternating)
Interlacing with scaler (no flicker filter, no interlaced addressing)	FB_H_ACTIVE	FB_V_ACTIVE	H_ACTIVE	V_ACTIVE or V_ACTIVE_EVEN (alternating)	H_ACTIVE	V_ACTIVE or V_ACTIVE_EVEN (alternating)
Interlacing with scaler and flicker filter	FB_H_ACTIVE	FB_V_ACTIVE	H_ACTIVE	V_ACTIVE + V_ACTIVE_EVEN + 11	H_ACTIVE	V_ACTIVE or V_ACTIVE_EVEN (alternating)
VGA (no scaling, interlacing, or flicker filter)	VGA CRTC	VGA CRTC	VGA CRTC	VGA CRTC	VGA CRTC	VGA CRTC
VGA with scaling (no interlacing or flicker filter)	VGA CRTC	VGA CRTC	H_ACTIVE	V_ACTIVE	H_ACTIVE	V_ACTIVE
VGA with scaling and interlacing (no flicker filter)	VGA CRTC	VGA CRTC	H_ACTIVE	V_ACTIVE or V_ACTIVE_EVEN (alternating)	H_ACTIVE	V_ACTIVE or V_ACTIVE_EVEN (alternating)
VGA with scaling, interlacing, and flicker filter	VGA CRTC	VGA CRTC	H_ACTIVE	V_ACTIVE + V_ACTIVE_EVEN + 11	H_ACTIVE	V_ACTIVE or V_ACTIVE_EVEN (alternating)

Note 1. Because the register value represents the image size minus 1, an additional 1 is added when these two register values are added together to retain the convention.

### 6.5.10 Interlaced Timing Examples

Figure 6-22 shows how the DC's timing registers are used to control timings for interlaced display modes. The SMTPE standards define the even and odd fields as starting at VSYNC, while the register settings define the timings based on the start of the active display region, as is common in (non-interlaced) VESA timing standards. As a result, the V\_Sync\_End and V\_Total register settings each define a region that begins in the odd field and ends in the next even field. Similarly, the V\_Sync\_Even\_End and

V\_Total\_Even register settings each define a region that begins in the even field and ends in the next odd field.

All register values are in hex; assuming VSYNC pulse width of one line.

Table 6-43 lists timings for various interlaced modes for reference. The user should verify these timings against current specifications for their application.) Table 6-44 on page 299 provides the corresponding register settings (hexadecimal values) for these modes. The VSYNC pulse is assumed to be one line wide. Further information on these registers can be found in Section 6.6.5 on page 327.

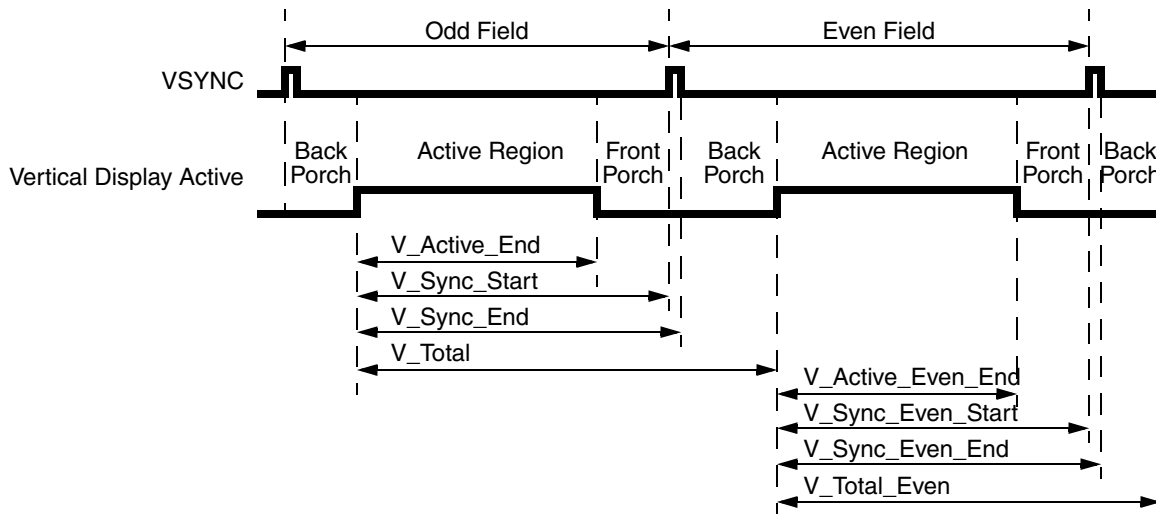


Figure 6-22. Interlaced Timing Settings

Table 6-43. Vertical Timing in Number of Lines

Timing Set	Odd Field			Even Field		
	Back Porch	Active	Front Porch	Back Porch	Active	Front Porch
525	16	242	2	17	241	3
625	22	288	2	23	288	2
720i	12	360	3	13	360	2
1080i	20	540	3	20	540	2
1080i 50 Hz	80	540	5	80	540	5

Table 6-44. Timing Register Settings for Interlaced Modes

Timing Set	Parameter	Odd Register	Even Register
Formula	V_Active_End	(odd_active-1)	(even_active-1)
	V_Total	(odd_active + odd_fp + even_bp - 1)	(even_active + even_fp + odd_bp - 1)
	V_Sync_Start	(odd_active + odd_fp - 1)	(even_active + even_fp - 1)
	V_Sync_End	(odd_active + odd_fp + odd_vsync - 1)	(even_active + even_fp + even_vsync - 1)
525	V_Active_End	F1	F0
	V_Total	106	105
	V_Sync_Start	F5	F5
	V_Sync_End	F6	F6
625	V_Active_End	11F	11F
	V_Total	138	137
	V_Sync_Start	121	121
	V_Sync_End	122	122
720i	V_Active_End	167	167
	V_Total	177	177
	V_Sync_Start	16A	169
	V_Sync_End	16B	16A
1080i	V_Active_End	21B	21B
	V_Total	232	231
	V_Sync_Start	21E	21D
	V_Sync_End	21F	21E
1080i 50 Hz	V_Active_End	21B	21B
	V_Total	270	270
	V_Sync_Start	220	220
	V_Sync_End	221	221

## 6.6 Display Controller Register Descriptions

This section provides information on the registers associated with the Display Controller (DC) (i.e., GUI and VGA blocks), including the Standard GeodeLink™ Device (GLD) MSRs and the Display Controller Specific MSRs (accessed via the RDMSR and WRMSR instructions). Table 6-45 through Table 6-50 are register summary tables that

include reset values and page references where the bit descriptions are provided.

**Note:** The MSR address is derived from the perspective of the CPU Core. See Section 4.1 "MSR Set" on page 45 for more details on MSR addressing.

**Table 6-45. Standard GeodeLink™ Device MSRs Summary**

MSR Address	Type	Register Name	Reset Value	Reference
80002000h	RO	GLD Capabilities MSR (GLD_MSR_CAP)	00000000_0003E4xxh	Page 305
80002001h	R/W	GLD Master Configuration MSR (GLD_MSR_CONFIG)	00000000_00000000h	Page 305
80002002h	R/W	GLIU0 Device SMI MSR (GLD_MSR_SMI)	00000000_00000000h	Page 306
80002003h	R/W	GLD Error MSR (GLD_MSR_ERROR)	00000000_00000000h	Page 308
80002004h	R/W	GLD Power Management MSR (GLD_MSR_PM)	00000000_00000015h	Page 310
80002005h	R/W	GLIU0 Device Diagnostic MSR (GLD_MSR_DIAG)	00000000_00000000h	Page 310

**Table 6-46. DC Specific MSRs Summary**

MSR Address	Type	Register Name	Reset Value	Reference
80000012h	R/W	DC RAM Control MSR (DC_RAM_CTL_MSR)	00000000_02020202h	Page 311

**Table 6-47. DC Configuration Control Register Summary**

DC Memory Offset	Type	Register Name	Reset Value	Reference
<b>Configuration and Status Registers</b>				
000h	R/W	DC Unlock (DC_UNLOCK)	00000000h	Page 312
004h	R/W	DC General Configuration (DC_GENERAL_CFG)	00000000h	Page 314
008h	R/W	DC Display Configuration (DC_DISPLAY_CFG)	00000000h	Page 317
00Ch	R/W	DC Arbitration Configuration (DC_ARB_CFG)	00000000h	Page 319
<b>Memory Organization Registers</b>				
010h	R/W	DC Frame Buffer Start Address (DC_FB_ST_OFFSET)	xxxxxxxh	Page 321
014h	R/W	DC Compression Buffer Start Address (DC_CB_ST_OFFSET)	xxxxxxxh	Page 322
018h	R/W	DC Cursor Buffer Start Address (DC_CURS_ST_OFFSET)	xxxxxxxh	Page 322

Table 6-47. DC Configuration Control Register Summary (Continued)

DC Memory Offset	Type	Register Name	Reset Value	Reference
020h	R/W	DC Video Y Buffer Start Address Offset (DC_VID_Y_ST_OFFSET)	xxxxxxxxh	Page 323
024h	R/W	DC Video U Buffer Start Address Offset (DC_VID_U_ST_OFFSET)	xxxxxxxxh	Page 323
028h	R/W	DC Video V Buffer Start Address Offset (DC_VID_V_ST_OFFSET)	xxxxxxxxh	Page 324
02Ch	R/W	DC Dirty/Valid Region Top (DC_DV_TOP)	00000000h	Page 324
030h	R/W	DC Line Size (DC_LINE_SIZE)	xxxxxxxxh	Page 325
034h	R/W	DC Graphics Pitch (DC_GFX_PITCH)	xxxxxxxxh	Page 326
038h	R/W	DC Video YUV Pitch (DC_VID_YUV_PITCH)	xxxxxxxxh	Page 326
<b>Timing Registers</b>				
040h	R/W	DC Horizontal and Total Timing (DC_H_ACTIVE_TIMING)	xxxxxxxxh	Page 328
044h	R/W	DC CRT Horizontal Blanking Timing (DC_H_BLANK_TIMING)	xxxxxxxxh	Page 329
048h	R/W	DC CRT Horizontal Sync Timing (DC_H_SYNC_TIMING)	xxxxxxxxh	Page 329
050h	R/W	DC Vertical and Total Timing (DC_V_ACTIVE_TIMING)	xxxxxxxxh	Page 330
054h	R/W	DC CRT Vertical Blank Timing (DC_V_BLANK_TIMING)	xxxxxxxxh	Page 331
058h	R/W	DC CRT Vertical Sync Timing (DC_V_SYNC_TIMING)	xxxxxxxxh	Page 331
05Ch	R/W	DC Frame Buffer Active Region Register (DC_FB_ACTIVE)	xxxxxxxxh	Page 332
<b>Cursor Position and Count Status Registers</b>				
060h	R/W	DC Cursor X Position (DC_CURSOR_X)	xxxxxxxxh	Page 332
064h	R/W	DC Cursor Y Position (DC_CURSOR_Y)	xxxxxxxxh	Page 333
06Ch	RO	DC Line Count/Status (DC_LINE_CNT/STATUS)	xxxxxxxxh	Page 333
<b>Palette Access and FIFO Diagnostic Registers</b>				
070h	R/W	DC Palette Address (DC_PAL_ADDRESS)	xxxxxxxxh	Page 335
074h	R/W	DC Palette Data (DC_PAL_DATA)	xxxxxxxxh	Page 336
078h	R/W	DC Display FIFO Diagnostic (DC_DFIFO_DIAG)	xxxxxxxxh	Page 336
07Ch	R/W	DC Compression FIFO Diagnostic (DC_CFIFO_DIAG)	xxxxxxxxh	Page 337
<b>Video Downscaling Registers</b>				
080h	R/W	DC Video Downscaling Delta (DC_VID_DS_DELTA)	00000000h	Page 338
<b>GLIU0 Control Registers</b>				
084h	R/W	DC GLIU0 Memory Offset (DC_GLIU0_MEM_OFFSET)	00000000h	Page 339
088h	R/W	DC Dirty/Valid RAM Control (DC_DV_CTL)	00000000h	Page 339

Table 6-47. DC Configuration Control Register Summary (Continued)

DC Memory Offset	Type	Register Name	Reset Value	Reference
08Ch	R/W	DC Dirty/Valid RAM Access (DC_DV_ACCESS)	0000000xh	Page 340
<b>Graphics Scaling Control Registers</b>				
090h	R/W	DC Graphics Filter Scale (DC_GFX_SCALE)	40004000h	Page 341
094h	R/W	DC IRQ/Filter Control (DC_IRQ_FILTER_CTL)	00000000h	Page 342
098h	R/W	DC Filter Coefficient Data Register 1 (DC_FILTER_COEFF1)	xxxxxxxh	Page 343
09Ch	R/W	DC Filter Coefficient Data Register 2 (DC_FILTER_COEFF2)	xxxxxxxh	Page 344
<b>VBI Control Registers</b>				
0A0h	R/W	DC VBI Even Control (DC_VBI_EVEN_CTL)	xxxxxxxh	Page 344
0A4h	R/W	DC VBI Odd Control (DC_VBI_ODD_CTL)	xxxxxxxh	Page 345
0A8h	R/W	DC VBI Horizontal Control (DC_VBI_HOR)	xxxxxxxh	Page 345
0ACh	R/W	DC VBI Odd Line Enable (DC_VBI_LN_ODD)	xxxxxxxh	Page 346
0B0h	R/W	DC VBI Even Line Enable (DC_VBI_LN_EVEN)	xxxxxxxh	Page 346
0B4h	R/W	DC VBI Pitch and Size (DC_VBI_PITCH)	xxxxxxxh	Page 347
<b>Color Key Control Registers</b>				
0B8h	R/W	DC Color Key (DC_CLR_KEY)	00000000h	Page 347
0BCh	R/W	DC Color Key Mask (DC_CLR_KEY_MASK)	00xxxxxh	Page 348
0C0h	R/W	DC Color Key Horizontal Position (DC_CLR_KEY_X)	00000000h	Page 348
0C4h	R/W	DC Color Key Vertical Position (DC_CLR_KEY_Y)	00000000h	Page 348
<b>Interrupt and GenLock Registers</b>				
0C8h	R/W	DC Interrupt (DC_IRQ)	00000003h	Page 349
0D4h	R/W	DC GenLock Control (DC_GENLK_CTL)	xxxxxxxh	Page 350
<b>Even Field Video Address Registers</b>				
0D8h	R/W	DC Even Field Video Y Start Address Offset (DC_VID_EVEN_Y_ST_OFFSET)	xxxxxxxh	Page 351
0DCh	R/W	DC Even Field Video U Start Address Offset (DC_VID_EVEN_U_ST_OFFSET)	xxxxxxxh	Page 352
0E0h	R/W	DC Even Field Video V Start Address Offset (DC_VID_EVEN_V_ST_OFFSET)	xxxxxxxh	Page 352
<b>Even Field Vertical Timing Registers</b>				
0E4h	R/W	DC Vertical and Total Timing for Even Fields (DC_V_ACTIVE_EVEN_TIMING)	xxxxxxxh	Page 353
0E8h	R/W	DC CRT Vertical Blank Timing for Even Fields (DC_V_BLANK_EVEN_TIMING)	xxxxxxxh	Page 354
0ECh	R/W	DC CRT Vertical Sync Timing for Even Fields (DC_V_SYNC_EVEN_TIMING)	xxxxxxxh	Page 354

Table 6-48. VGA Block Configuration Register Summary

DC Memory Offset	Type	Register Name	Reset Value	Reference
100h	R/W	VGA Configuration (VGA_CONFIG)	00000000h	Page 355
104h	RO	VGA Status (VGA_STATUS)	00000000h	Page 355

Table 6-49. VGA Block Standard Register Summary

I/O Read Address	I/O Write Address	Register Name/Group	Reset Value	Reference
3CCh	3C2h (W)	VGA Miscellaneous Output	02h	Page 356
3C2h	--	VGA Input Status Register 0	00h	Page 357
3BAh or 3DAh (Note 1)	--	VGA Input Status Register 1	01h	Page 357
3CAh	3BAh or 3DAh (Note 1)	VGA Feature Control	xxh	Page 357
3C4h		VGA Sequencer Index	0xh	Page 358
3C5h		VGA Sequencer Data	xxh	Page 358
3B4h or 3D4h (Note 1)		CRTC Index	00h	Page 362
3B5h or 3D5h (Note 1)		CRTC Data	00h	Page 363
3CEh		VGA Graphics Controller Index	xxh	Page 373
3CFh		VGA Graphics Controller Data	xxh	Page 374
3C0h		Attribute Controller Index/Data	xxh	Page 379
3C1h (R)	3C0h (W)			
3C8h	3C7h (Palette Read Mode)	Video DAC Palette Address	00h	Page 382
	3C8h (Palette Write Mode)			
3C7h--		Video DAC State	00h	Page 383
3C9h		Video DAC Palette Data	00h	Page 383
3C6h		Video DAC Palette Mask	00h	Page 384

Note 1. The I/O addresses are determined by bit 0 of the Miscellaneous Output Register. See the description of this register in Section 6.6.17.1 on page 356 for more information.

**Table 6-50. VGA Block Extended Register Summary**

VGA CRTC Index	Type	Register Name	Reset Value	Reference
0030h	R/W	ExtendedRegisterLock	FFh	Page 385
043h	R/W	ExtendedModeControl	00h	Page 385
044h	R/W	ExtendedStartAddress	00h	Page 385
047h	R/W	WriteMemoryAperture	00h	Page 386
048h	R/W	ReadMemoryAperture	00h	Page 386
060h	R/W	BlinkCounterCtl	00h	Page 386
061h	RO	BlinkCounter	00h	Page 387
070h	R/W	VGALatchSavRes	00h	Page 387
071h	R/W	DACIFSavRes	00h	Page 387



## 6.6.1 Standard GeodeLink™ Device (GLD) Registers (MSRs)

### 6.6.1.1 GLD Capabilities MSR (GLD\_MSR\_CAP)

MSR Address 80002000h  
 Type RO  
 Reset Value 00000000\_0003E4xxh

**GLD\_MSR\_CAP Register Map**

63	62	61	60	59	58	57	56	55	54	53	52	51	50	49	48	47	46	45	44	43	42	41	40	39	38	37	36	35	34	33	32
RSVD																															
31	30	29	28	27	26	25	24	23	22	21	20	19	18	17	16	15	14	13	12	11	10	9	8	7	6	5	4	3	2	1	0
RSVD								DEV_ID														REV_ID									

**GLD\_MSR\_CAP Bit Descriptions**

Bit	Name	Description
63:24	RSVD	<b>Reserved.</b> Set to 0.
23:8	DEV_ID	<b>Device ID.</b> Identifies device (03E4h).
7:0	REV_ID	<b>Revision ID.</b> Identifies device revision. See <i>AMD Geode™ LX Processors Specification Update</i> document for value.

### 6.6.1.2 GLD Master Configuration MSR (GLD\_MSR\_CONFIG)

MSR Address 80002001h  
 Type R/W  
 Reset Value 00000000\_00000000h

**GLD\_MSR\_CONFIG Register Map**

63	62	61	60	59	58	57	56	55	54	53	52	51	50	49	48	47	46	45	44	43	42	41	40	39	38	37	36	35	34	33	32
RSVD																															
31	30	29	28	27	26	25	24	23	22	21	20	19	18	17	16	15	14	13	12	11	10	9	8	7	6	5	4	3	2	1	0
RSVD																					PRI1		RSVD	PRI0		RSVD	PID				

**GLD\_MSR\_CONFIG Bit Descriptions**

Bit	Name	Description
63:11	RSVD	<b>Reserved.</b> Set to 0.
10:8	PRI1	<b>Secondary Priority Level.</b> This value is the priority level the DC uses when performing high priority GLIU0 accesses. This is the case when the FIFOs are nearly empty.
7	RSVD	<b>Reserved.</b> Set to 0.
6:4	PRI0	<b>Primary Priority Level.</b> This value is the priority level the DC uses for most accesses (i.e., when the display FIFO is not in danger of being emptied).
3	RSVD	<b>Reserved.</b> Set to 0.
2:0	PID	<b>Priority ID.</b> This value is the Priority ID (PID) value used when the DC initiates GLIU0 transactions.

**6.6.1.3 GLIU0 Device SMI MSR (GLD\_MSR\_SMI)**

MSR Address 80002002h  
 Type R/W  
 Reset Value 00000000\_00000000h

**GLD\_MSR\_SMI Register Map**

63	62	61	60	59	58	57	56	55	54	53	52	51	50	49	48	47	46	45	44	43	42	41	40	39	38	37	36	35	34	33	32
RSVD			VGA_RES_CHANGE_SMI	RSVD												ISR1R_SMI	MISCIOR_SMI	DACIOR_SMI	DACIOW_SMI	ATRIOR_SMI	ATRIOW_SMI	GFXIOR_SMI	GFXIOW_SMI	SEQIOR_SMI	SEQIOW_SMI	CRTCIOR_SMI	CRTCIO_SMI	VGA_BL_SMI	ISR0_SMI	MISC_SMI	VG_BL_SMI
31	30	29	28	27	26	25	24	23	22	21	20	19	18	17	16	15	14	13	12	11	10	9	8	7	6	5	4	3	2	1	0
RSVD			VGA_RES_CHANGE_MASK	RSVD												ISR1R_MSK	MISCIOR_MSK	DACIOR_MSK	DACIOW_MSK	ATRIOR_MSK	ATRIOW_MSK	GFXIOR_MSK	GFXIOW_MSK	SEQIOR_MSK	SEQIOW_MSK	CRTCIOR_MSK	CRTCIO_MSK	VGA_BL_MSK	ISR0_MSK	MISC_MSK	VG_BL_MSK

**GLD\_MSR\_SMI Bit Descriptions**

Bit	Name	Description
63:61	RSVD	<b>Reserved.</b> Set to 0.
60	VGA_RES_CHANGE_SMI	<b>VGA Resolution Change SMI.</b> Reading a 1 indicates that the VGA's output image size has changed while scaling is enabled. The handler for this SMI should update the horizontal and/or vertical scale factor(s) accordingly.
59:49	RSVD	<b>Reserved.</b> Set to 0.
48	ISR1R_SMI	<b>Input Status Register 1 Read SMI.</b> Reading a 1 indicates that the VGA Input Status Register 1 has been read; writing this bit to 1 clears it.
47	MISCIOR_SMI	<b>Miscellaneous Output Register Read SMI.</b> Reading a 1 indicates that the VGA Miscellaneous Output Register has been read; writing this bit to 1 clears it.
46	DACIOR_SMI	<b>Video DAC Register Read SMI.</b> Reading a 1 indicates that one or more of the VGA's Video DAC registers has been read; writing a 1 to this bit clears it.
45	DACIOW_SMI	<b>Video DAC Register Write SMI.</b> Reading a 1 indicates that one or more of the VGA's Video DAC registers has been written; writing a 1 to this bit clears it.
44	ATRIOR_SMI	<b>Attribute Register Read SMI.</b> Reading a 1 indicates that one or more of the VGA's Attribute registers has been read; writing a 1 to this bit clears it.
43	ATRIOW_SMI	<b>Attribute Register Write SMI.</b> Reading a 1 indicates that one or more of the VGA's Attribute registers has been written; writing a 1 to this bit clears it.
42	GFXIOR_SMI	<b>Graphics Controller Register Read SMI.</b> Reading a 1 indicates that one or more of the VGA's Graphics Controller registers has been read; writing a 1 to this bit clears it.
41	GFXIOW_SMI	<b>Graphics Controller Register Write SMI.</b> Reading a 1 indicates that one or more of the VGA's Graphics Controller registers has been written; writing a 1 to this bit clears it.

## GLD\_MSR\_SMI Bit Descriptions (Continued)

Bit	Name	Description
40	SEQIOR_SMI	<b>Sequencer Register Read SMI.</b> Reading a 1 indicates that one or more of the VGA's Sequencer registers has been read; writing a 1 to this bit clears it.
39	SEQIOW_SMI	<b>Sequencer Register Write SMI.</b> Reading a 1 indicates that one or more of the VGA's Sequencer registers has been written; writing a 1 to this bit clears it.
38	CRTCIOR_SMI	<b>CRTC Register Read SMI.</b> Reading a 1 indicates that one or more of the VGA's CRTC registers has been read; writing a 1 to this bit clears it.
37	CRTCIO_SMI	<b>CRTC Register Write SMI.</b> Reading a 1 indicates that one or more of the VGA's CRTC registers has been written; writing a 1 to this bit clears it.
36	CRTCIO_SMI	<b>CRTC Invalid Register I/O SMI.</b> Reading a 1 indicates that this SMI has been generated; writing a 1 to this bit clears it; writing 0 has no effect.
35	VGA_BL_SMI	<b>VGA Vertical Blank SMI.</b> Reading a 1 indicates that the ASMI corresponding to VGA Vertical Blank has been triggered. Writing a 1 to this bit clears it (and deactivates the ASMI signal); writing a 0 to this bit has no effect.
34	ISR0_SMI	<b>Input Status Register 0 SMI.</b> Reading a 1 indicates that a synchronous SMI was generated because of a read to VGA Input Status Register 0. Writing a 1 to this bit clears it; writing a 0 has no effect.
33	MISC_SMI	<b>Miscellaneous Output Register SMI.</b> Reading a 1 indicates that a synchronous SMI was generated due to a write to the Miscellaneous Output Register. Writing a 1 to this bit clears it; writing a 0 has no effect.
32	VG_BL_SMI	<b>DC Vertical Blank SMI.</b> Reading a 1 indicates that the ASMI corresponding to DC Vertical Blank has been triggered. Writing a 1 to this bit clears it (and deactivates the ASMI signal); writing a 0 has no effect.
31:29	RSVD	<b>Reserved.</b> Set to 0.
28	VGA_RES_CHANGE_MASK	<b>VGA Resolution Change SMI Mask.</b> When set to 1, disables generation of an asynchronous SMI when all of the following conditions occur at once: <ul style="list-style-type: none"> <li>- The VGA timing engine is enabled.</li> <li>- Scaling is enabled.</li> <li>- The horizontal or vertical resolution of the image produced by the VGA timing engine changes.</li> </ul>
27:17	RSVD	<b>Reserved.</b> Set to 0.
16	ISR1R_MSK	<b>Input Status Register 1 Read SMI Mask.</b> When set to 1, disables generation of the SMI that indicates that VGA Input Status Register 1 has been read.
15	MSICIOR_MSK	<b>Miscellaneous Output Register Read SMI.</b> When set to 1, disables generation of the SMI that indicates that the VGA Miscellaneous Output Register has been read.
14	DACIOR_MSK	<b>Video DAC Register Read SMI.</b> When set to 1, disables generation of the SMI that indicates that one or more of the VGA's Video DAC registers has been read.
13	DACIOW_MSK	<b>Video DAC Register Write SMI.</b> When set to 1, disables generation of the SMI that indicates that one or more of the VGA's Video DAC registers has been written.
12	ATRIOR_MSK	<b>Attribute Register Read SMI.</b> When set to 1, disables generation of the SMI that indicates that one or more of the VGA's Attribute registers has been read.
11	ATRIOW_MSK	<b>Attribute Register Write SMI.</b> When set to 1, disables generation of the SMI that indicates that one or more of the VGA's Attribute registers has been written.
10	GFXIOR_MSK	<b>Graphics Controller Register Read SMI.</b> When set to 1, disables generation of the SMI that indicates that one or more of the VGA's Graphics Controller registers has been read.

**GLD\_MSR\_SMI Bit Descriptions (Continued)**

Bit	Name	Description
9	GFXIOW_MSK	<b>Graphics Controller Register Write SMI.</b> When set to 1, disables generation of the SMI that indicates that one or more of the VGA's Graphics Controller registers has been written.
8	SEQIOR_MSK	<b>Sequencer Register Read SMI.</b> When set to 1, disables generation of the SMI that indicates that one or more of the VGA's Sequencer registers has been read.
7	SEQIOW_MSK	<b>Sequencer Register Write SMI.</b> When set to 1, disables generation of the SMI that indicates that one or more of the VGA's Sequencer registers has been written.
6	CRTCIOR_MSK	<b>CRTC Register Read SMI.</b> When set to 1, disables generation of the SMI that indicates that one or more of the VGA's CRTC registers has been read; writing a 1 to this bit clears it.
5	CRTCIOIOW_MSK	<b>CRTC Register Write SMI.</b> When set to 1, disables generation of the SMI that indicates that one or more of the VGA's CRTC registers has been written.
4	CRTCIO_MSK	<b>CRTC Invalid Register I/O SMI Mask.</b> When set to 1, disables generation of a synchronous SMI when a non-implemented VGA CRT Controller Register is read or written.
3	VGA_BL_MSK	<b>VGA Vertical Blank SMI Mask.</b> When set to 1, disables generation of the VGA Vertical Blank SMI.
2	ISRO_MSK	<b>Input Status Register 0 SMI Mask.</b> When set to 1, disables generation of the VGA Input Status Register SMI.
1	MISC_MSK	<b>Miscellaneous Output Register SMI Mask.</b> When set to 1, disables generation of the Miscellaneous Output Register synchronous SMI.
0	VG_BL_MSK	<b>DC Vertical Blank SMI Mask.</b> When set to 1, disables the DC Vertical Blank SMI when set to 1.

**6.6.1.4 GLD Error MSR (GLD\_MSR\_ERROR)**

MSR Address 80002003h  
 Type R/W  
 Reset Value 00000000\_00000000h

**GLD\_MSR\_ERROR Register Map**

63	62	61	60	59	58	57	56	55	54	53	52	51	50	49	48	47	46	45	44	43	42	41	40	39	38	37	36	35	34	33	32	
RSVD																											CWD_CHECK_ERR	SYNCFBUF_ERR	DFIFO_ERR	SMI_ERR	ADDR_ERR	TYPE_ERR
31	30	29	28	27	26	25	24	23	22	21	20	19	18	17	16	15	14	13	12	11	10	9	8	7	6	5	4	3	2	1	0	
RSVD																											CWD_CHECK_MASK	SYNCFBUF_MASK	DFIFO_ERR_MASK	SMI_ERR_MASK	ADDR_ERR_MASK	TYPE_ERR_MASK

## GLD\_MSR\_ERROR Bit Descriptions

Bit	Name	Description
63:38	RSVD	<b>Reserved.</b> Set to 0.
37	CWD_CHECK_ERR	<b>Control Word Check Error.</b> Reading a 1 indicates that an invalid control word was read from the Display FIFO, which is indicative of a FIFO underrun. Writing a 1 to this bit clears it.
36	SYNCBUF_ERR	<b>Synchronizer Buffer Error.</b> Reading a 1 indicates that the display pipe attempted to read the synchronizer buffer while it was invalid. This is indicative of a synchronizer buffer underrun. Writing a 1 to this bit clears it.
35	DFIFO_ERR	<b>Display FIFO Underrun Error.</b> Reading a 1 indicates that the asynchronous error signal is being driven because the display FIFO has “run dry”. This implies that at least one frame of the display was corrupted. Writing a 1 to this bit clears it; writing a 0 has no effect.
34	SMI_ERR	<b>Uncleared SMI Error.</b> Reading a 1 indicates that the asynchronous error signal is being driven because a second SMI occurred while the first SMI went unserved.
33	ADDR_ERR	<b>Unexpected Address Error.</b> Reading a 1 indicates that the exception flag was set because the DC received a GLIU0 transaction request.
32	TYPE_ERR	<b>Unexpected Type Error.</b> Reading a 1 indicates that an asynchronous error has occurred because the DC received a GLIU0 transaction with an undefined or unexpected type.
31:6	RSVD	<b>Reserved.</b> Set to 0.
5	CWD_CHECK_MSK	<b>Control Word Check Error Mask.</b> When set to 1, disables generation of the asynchronous error signal when an invalid control word is read from the data FIFO.
4	SYNCBUF_MSK	<b>Synchronizer Buffer Error Mask.</b> When set to 1, disables generation of the asynchronous error signal when invalid data is read from the synchronizer buffer.
3	DFIFO_ERR_MASK	<b>Display FIFO Underrun Error Mask.</b> When set to 1, disables generation of the asynchronous error signal when at least one frame of the display was corrupted.
2	SMI_ERR_MASK	<b>Uncleared SMI Error Mask.</b> When set to 1, disables generation of the asynchronous error signal when a second SMI occurred while the first SMI went unserved.
1	ADDR_ERR_MASK	<b>Unexpected Address Error Mask.</b> When set to 1, disables generation of an exception flag when the DC receives a GLIU0 request.
0	TYPE_ERR_MASK	<b>Unexpected Type Error Mask.</b> When set to 1, disables generation of the asynchronous error signal when the DC received a GLIU0 transaction with an undefined or unexpected type.

**6.6.1.5 GLD Power Management MSR (GLD\_MSR\_PM)**

MSR Address 80002004h  
 Type R/W  
 Reset Value 00000000\_00000015h

**GLD\_MSR\_PM Register Map**

63	62	61	60	59	58	57	56	55	54	53	52	51	50	49	48	47	46	45	44	43	42	41	40	39	38	37	36	35	34	33	32
RSVD																															
31	30	29	28	27	26	25	24	23	22	21	20	19	18	17	16	15	14	13	12	11	10	9	8	7	6	5	4	3	2	1	0
RSVD																								VGA_GLCLK_PMODE			DCLK_PMODE		GLCLK_PMODE		

**GLD\_MSR\_PM Bit Descriptions**

Bit	Name	Description
63:6	RSVD	<b>Reserved.</b> Set to 0.
5:4	VGA_GLCLK_PMODE	<b>VGA GLIU0 Clock Power Management Mode.</b> This field controls the internal clock gating for the GLIU0 clock to the VGA module. 00: Clock is not gated. 01: Enable active hardware clock gating. Hardware automatically determines when it is idle, and internally disables the GLIU0 clock whenever possible. 10: Reserved. 11: Reserved.
3:2	DCLK_PMODE	<b>Dot Clock Power Management Mode.</b> This field controls the internal clock gating for the Dot clock to all logic other than the VGA unit. 00: Clock is not gated. 01: Enable active hardware clock gating. Hardware automatically determines when it is idle, and internally disables the Dot clock whenever possible. 10: Reserved. 11: Reserved.
1:0	G:CLK_PMODE	<b>GLIU0 Clock Power Management Mode.</b> This field controls the internal clock gating for the GLIU0 Clock to all logic other than the VGA unit. 00: Clock is not gated. 01: Enable active hardware clock gating. Hardware automatically determines when it is idle, and internally disables the GLIU0 clock whenever possible. 10: Reserved. 11: Reserved.

**6.6.1.6 GLIU0 Device Diagnostic MSR (GLD\_MSR\_DIAG)**

MSR Address 80002005h  
 Type R/W  
 Reset Value 00000000\_00000000h

This register is reserved for internal use by AMD and should not be written to.

## 6.6.2 Display Controller Specific MSRs

### 6.6.2.1 SPARE MSR

MSR Address 80000011h  
 Type R/W  
 Reset Value 00000000\_00000000h

**SPARE\_MSR Register Map**

63	62	61	60	59	58	57	56	55	54	53	52	51	50	49	48	47	46	45	44	43	42	41	40	39	38	37	36	35	34	33	32
RSVD																															
31	30	29	28	27	26	25	24	23	22	21	20	19	18	17	16	15	14	13	12	11	10	9	8	7	6	5	4	3	2	1	0
RSVD																							DISABLE_VFIFO_WM	RSVD							

**SPARE\_MSR Bit Descriptions**

Bit	Name	Description
63:7	RSVD	<b>Reserved.</b>
6	DISABLE_VFIFO_WM	<b>Disable Video FIFO Watermarks.</b> When set, the video watermarks in DC_ARB_CFG[19:12] have no effect.
5:0	RSVD	<b>Reserved.</b>

### 6.6.2.2 DC RAM Control MSR (DC\_RAM\_CTL\_MSR)

MSR Address 80000012h  
 Type R/W  
 Reset Value 00000000\_02020202h

**DC\_RAM\_CTL\_MSR Register Map**

63	62	61	60	59	58	57	56	55	54	53	52	51	50	49	48	47	46	45	44	43	42	41	40	39	38	37	36	35	34	33	32
RSVD																															
31	30	29	28	27	26	25	24	23	22	21	20	19	18	17	16	15	14	13	12	11	10	9	8	7	6	5	4	3	2	1	0
RSVD																				CFIFO_CTL	RSVD					DV_RAM_CTL					

**DC\_RAM\_CTL\_MSR Bit Descriptions**

Bit	Name	Description
63:11	RSVD	<b>Reserved.</b>
10:8	CFIFO_CTL	<b>CFIFO RAM Delay Control.</b>
7:3	RSVD	<b>Reserved.</b>
2:0	DV_RAM_CTL	<b>DV RAM Delay Control.</b>

### 6.6.3 Configuration and Status Registers

All DC registers are DWORD accessible only.

#### 6.6.3.1 DC Unlock (DC\_UNLOCK)

DC Memory Offset 000h

Type R/W

Reset Value 00000000h

This register is provided to lock the most critical memory-mapped DC registers to prevent unwanted modification (write operations). Read operations are always allowed.

**DC\_UNLOCK Register Map**

31	30	29	28	27	26	25	24	23	22	21	20	19	18	17	16	15	14	13	12	11	10	9	8	7	6	5	4	3	2	1	0
RSVD																DC_UNLOCK															



## DC\_UNLOCK Bit Descriptions

Bit	Name	Description																																																																																								
31:16	RSVD	<b>Reserved.</b>																																																																																								
15:0	DC_UNLOCK	<p><b>Unlock Code.</b> This register must be written with the value 4758h in order to write to the protected registers. The following registers are protected by the locking mechanism:</p> <table> <tbody> <tr><td>DC_GENERAL_CFG</td><td>(DC Memory Offset 004h)</td></tr> <tr><td>DC_DISPLAY_CFG</td><td>(DC Memory Offset 008h)</td></tr> <tr><td>DC_ARB_CFG</td><td>(DC Memory Offset 00Ch)</td></tr> <tr><td>DC_FB_ST_OFFSET</td><td>(DC Memory Offset 010h)</td></tr> <tr><td>DC_CB_ST_OFFSET</td><td>(DC Memory Offset 014h)</td></tr> <tr><td>DC_CURS_ST_OFFSET</td><td>(DC Memory Offset 018h)</td></tr> <tr><td>DC_VID_Y_ST_OFFSET</td><td>(DC Memory Offset 020h)</td></tr> <tr><td>DC_VID_U_ST_OFFSET</td><td>(DC Memory Offset 024h)</td></tr> <tr><td>DC_VID_V_ST_OFFSET</td><td>(DC Memory Offset 028h)</td></tr> <tr><td>DC_LINE_SIZE</td><td>(DC Memory Offset 030h)</td></tr> <tr><td>DC_GFX_PITCH</td><td>(DC Memory Offset 034h)</td></tr> <tr><td>DC_VID_YUV_PITCH</td><td>(DC Memory Offset 038h)</td></tr> <tr><td>DC_H_ACTIVE_TIMING</td><td>(DC Memory Offset 040h)</td></tr> <tr><td>DC_H_BLANK_TIMING</td><td>(DC Memory Offset 044h)</td></tr> <tr><td>DC_H_SYNC_TIMING</td><td>(DC Memory Offset 048h)</td></tr> <tr><td>DC_V_ACTIVE_TIMING</td><td>(DC Memory Offset 050h)</td></tr> <tr><td>DC_V_BLANK_TIMING</td><td>(DC Memory Offset 054h)</td></tr> <tr><td>DC_V_SYNC_TIMING</td><td>(DC Memory Offset 058h)</td></tr> <tr><td>DC_DFIFO_DIAG</td><td>(DC Memory Offset 078h)</td></tr> <tr><td>DC_CFIFO_DIAG</td><td>(DC Memory Offset 07Ch)</td></tr> <tr><td>DC_VID_DS_DELTA</td><td>(DC Memory Offset 080h)</td></tr> <tr><td>DC_GLIU0_MEM_OFFSET</td><td>(DC Memory Offset 084h)</td></tr> <tr><td>DC_DV_CTL</td><td>(DC Memory Offset 088h)</td></tr> <tr><td>DC_GFX_SCALE</td><td>(DC Memory Offset 090h)</td></tr> <tr><td>DC_IRQ_FILT_CTL</td><td>(DC Memory Offset 094h)</td></tr> <tr><td>DC_FILT_COEFF1</td><td>(DC Memory Offset 098h)</td></tr> <tr><td>DC_FILT_COEFF2</td><td>(DC Memory Offset 09Ch)</td></tr> <tr><td>DC_VBI_EVEN_CTL</td><td>(DC Memory Offset 0A0h)</td></tr> <tr><td>DC_VBI_ODD_CTL</td><td>(DC Memory Offset 0A4h)</td></tr> <tr><td>DC_VBI_HOR_CTL</td><td>(DC Memory Offset 0A8h)</td></tr> <tr><td>DC_VBI_LN_ODD</td><td>(DC Memory Offset 0ACh)</td></tr> <tr><td>DC_VBI_LN_EVEN</td><td>(DC Memory Offset 0B0h)</td></tr> <tr><td>DC_VBI_PITCH</td><td>(DC Memory Offset 0B4h)</td></tr> <tr><td>DC_CLR_KEY</td><td>(DC Memory Offset 0B8h)</td></tr> <tr><td>DC_CLR_KEY_MASK</td><td>(DC Memory Offset 0BCh)</td></tr> <tr><td>DC_CLR_KEY_X</td><td>(DC Memory Offset 0C0h)</td></tr> <tr><td>DC_CLR_KEY_Y</td><td>(DC Memory Offset 0C4h)</td></tr> <tr><td>DC_GENLK_CTL</td><td>(DC Memory Offset 0D4h)</td></tr> <tr><td>DC_VID_EVEN_Y_ST_OFFSET</td><td>(DC Memory Offset 0D8h)</td></tr> <tr><td>DC_VID_EVEN_U_ST_OFFSET</td><td>(DC Memory Offset 0DCh)</td></tr> <tr><td>DC_VID_EVEN_V_ST_OFFSET</td><td>(DC Memory Offset 0E0h)</td></tr> <tr><td>DC_V_ACTIVE_EVEN_TIMING</td><td>(DC Memory Offset 0E4h)</td></tr> <tr><td>DC_V_BLANK_EVEN_TIMING</td><td>(DC Memory Offset 0E8h)</td></tr> <tr><td>DC_V_SYNC_EVEN_TIMING</td><td>(DC Memory Offset 0ECh)</td></tr> </tbody> </table>	DC_GENERAL_CFG	(DC Memory Offset 004h)	DC_DISPLAY_CFG	(DC Memory Offset 008h)	DC_ARB_CFG	(DC Memory Offset 00Ch)	DC_FB_ST_OFFSET	(DC Memory Offset 010h)	DC_CB_ST_OFFSET	(DC Memory Offset 014h)	DC_CURS_ST_OFFSET	(DC Memory Offset 018h)	DC_VID_Y_ST_OFFSET	(DC Memory Offset 020h)	DC_VID_U_ST_OFFSET	(DC Memory Offset 024h)	DC_VID_V_ST_OFFSET	(DC Memory Offset 028h)	DC_LINE_SIZE	(DC Memory Offset 030h)	DC_GFX_PITCH	(DC Memory Offset 034h)	DC_VID_YUV_PITCH	(DC Memory Offset 038h)	DC_H_ACTIVE_TIMING	(DC Memory Offset 040h)	DC_H_BLANK_TIMING	(DC Memory Offset 044h)	DC_H_SYNC_TIMING	(DC Memory Offset 048h)	DC_V_ACTIVE_TIMING	(DC Memory Offset 050h)	DC_V_BLANK_TIMING	(DC Memory Offset 054h)	DC_V_SYNC_TIMING	(DC Memory Offset 058h)	DC_DFIFO_DIAG	(DC Memory Offset 078h)	DC_CFIFO_DIAG	(DC Memory Offset 07Ch)	DC_VID_DS_DELTA	(DC Memory Offset 080h)	DC_GLIU0_MEM_OFFSET	(DC Memory Offset 084h)	DC_DV_CTL	(DC Memory Offset 088h)	DC_GFX_SCALE	(DC Memory Offset 090h)	DC_IRQ_FILT_CTL	(DC Memory Offset 094h)	DC_FILT_COEFF1	(DC Memory Offset 098h)	DC_FILT_COEFF2	(DC Memory Offset 09Ch)	DC_VBI_EVEN_CTL	(DC Memory Offset 0A0h)	DC_VBI_ODD_CTL	(DC Memory Offset 0A4h)	DC_VBI_HOR_CTL	(DC Memory Offset 0A8h)	DC_VBI_LN_ODD	(DC Memory Offset 0ACh)	DC_VBI_LN_EVEN	(DC Memory Offset 0B0h)	DC_VBI_PITCH	(DC Memory Offset 0B4h)	DC_CLR_KEY	(DC Memory Offset 0B8h)	DC_CLR_KEY_MASK	(DC Memory Offset 0BCh)	DC_CLR_KEY_X	(DC Memory Offset 0C0h)	DC_CLR_KEY_Y	(DC Memory Offset 0C4h)	DC_GENLK_CTL	(DC Memory Offset 0D4h)	DC_VID_EVEN_Y_ST_OFFSET	(DC Memory Offset 0D8h)	DC_VID_EVEN_U_ST_OFFSET	(DC Memory Offset 0DCh)	DC_VID_EVEN_V_ST_OFFSET	(DC Memory Offset 0E0h)	DC_V_ACTIVE_EVEN_TIMING	(DC Memory Offset 0E4h)	DC_V_BLANK_EVEN_TIMING	(DC Memory Offset 0E8h)	DC_V_SYNC_EVEN_TIMING	(DC Memory Offset 0ECh)
DC_GENERAL_CFG	(DC Memory Offset 004h)																																																																																									
DC_DISPLAY_CFG	(DC Memory Offset 008h)																																																																																									
DC_ARB_CFG	(DC Memory Offset 00Ch)																																																																																									
DC_FB_ST_OFFSET	(DC Memory Offset 010h)																																																																																									
DC_CB_ST_OFFSET	(DC Memory Offset 014h)																																																																																									
DC_CURS_ST_OFFSET	(DC Memory Offset 018h)																																																																																									
DC_VID_Y_ST_OFFSET	(DC Memory Offset 020h)																																																																																									
DC_VID_U_ST_OFFSET	(DC Memory Offset 024h)																																																																																									
DC_VID_V_ST_OFFSET	(DC Memory Offset 028h)																																																																																									
DC_LINE_SIZE	(DC Memory Offset 030h)																																																																																									
DC_GFX_PITCH	(DC Memory Offset 034h)																																																																																									
DC_VID_YUV_PITCH	(DC Memory Offset 038h)																																																																																									
DC_H_ACTIVE_TIMING	(DC Memory Offset 040h)																																																																																									
DC_H_BLANK_TIMING	(DC Memory Offset 044h)																																																																																									
DC_H_SYNC_TIMING	(DC Memory Offset 048h)																																																																																									
DC_V_ACTIVE_TIMING	(DC Memory Offset 050h)																																																																																									
DC_V_BLANK_TIMING	(DC Memory Offset 054h)																																																																																									
DC_V_SYNC_TIMING	(DC Memory Offset 058h)																																																																																									
DC_DFIFO_DIAG	(DC Memory Offset 078h)																																																																																									
DC_CFIFO_DIAG	(DC Memory Offset 07Ch)																																																																																									
DC_VID_DS_DELTA	(DC Memory Offset 080h)																																																																																									
DC_GLIU0_MEM_OFFSET	(DC Memory Offset 084h)																																																																																									
DC_DV_CTL	(DC Memory Offset 088h)																																																																																									
DC_GFX_SCALE	(DC Memory Offset 090h)																																																																																									
DC_IRQ_FILT_CTL	(DC Memory Offset 094h)																																																																																									
DC_FILT_COEFF1	(DC Memory Offset 098h)																																																																																									
DC_FILT_COEFF2	(DC Memory Offset 09Ch)																																																																																									
DC_VBI_EVEN_CTL	(DC Memory Offset 0A0h)																																																																																									
DC_VBI_ODD_CTL	(DC Memory Offset 0A4h)																																																																																									
DC_VBI_HOR_CTL	(DC Memory Offset 0A8h)																																																																																									
DC_VBI_LN_ODD	(DC Memory Offset 0ACh)																																																																																									
DC_VBI_LN_EVEN	(DC Memory Offset 0B0h)																																																																																									
DC_VBI_PITCH	(DC Memory Offset 0B4h)																																																																																									
DC_CLR_KEY	(DC Memory Offset 0B8h)																																																																																									
DC_CLR_KEY_MASK	(DC Memory Offset 0BCh)																																																																																									
DC_CLR_KEY_X	(DC Memory Offset 0C0h)																																																																																									
DC_CLR_KEY_Y	(DC Memory Offset 0C4h)																																																																																									
DC_GENLK_CTL	(DC Memory Offset 0D4h)																																																																																									
DC_VID_EVEN_Y_ST_OFFSET	(DC Memory Offset 0D8h)																																																																																									
DC_VID_EVEN_U_ST_OFFSET	(DC Memory Offset 0DCh)																																																																																									
DC_VID_EVEN_V_ST_OFFSET	(DC Memory Offset 0E0h)																																																																																									
DC_V_ACTIVE_EVEN_TIMING	(DC Memory Offset 0E4h)																																																																																									
DC_V_BLANK_EVEN_TIMING	(DC Memory Offset 0E8h)																																																																																									
DC_V_SYNC_EVEN_TIMING	(DC Memory Offset 0ECh)																																																																																									

### 6.6.3.2 DC General Configuration (DC\_GENERAL\_CFG)

DC Memory Offset 004h

Type R/W

Reset Value 00000000h

This register contains general control bits for the DC. Unless otherwise noted in the bit descriptions table, settings written to this register do not take effect until the start of the following frame or interlaced field.

**DC\_GENERAL\_CFG Register Map**

31	30	29	28	27	26	25	24	23	22	21	20	19	18	17	16	15	14	13	12	11	10	9	8	7	6	5	4	3	2	1	0
DEBUG	DBSL	CFRW	DIAG	CRC_MODE	SGFR	SGRE	SIGE	SIG_SEL	FRC8PIX	RSVD	YUVM	VDSE	VGAFT	FDTY	STFM	DFHPEL				DFHPSL				VGAE	DECE	CMPE	FILT_SIG_SEL	VIDE	CLR_CUR	CURE	DFLE

**DC\_GENERAL\_CFG Bit Descriptions**

Bit	Name	Description
31	DEBUG	<b>Debug Mode.</b> Effective immediately. 0: Disable 1: Enable.
30	DBSL	<b>Debug Select.</b> Effective immediately. 0: FIFO control signals transmitted to debug port. 1: Memory control signals transmitted to debug port.
29	CFRW	<b>Compressed Line Buffer Read/Write Select.</b> Effective immediately. Only has effect if in DIAG mode (bit 28 = 1). 0: Write address enabled to Compressed Line Buffer (CLB) in diagnostic mode. 1: Read address enabled to CLB in diagnostic mode.
28	DIAG	<b>RAM Diagnostic Mode.</b> Effective immediately. 0: Normal operation. 1: RAM diagnostic mode. This bit allows testability of the on-chip Display FIFO and CLB via the diagnostic access registers. A low to high transition resets the Display FIFO and Compressed Line Buffer read and write pointers.
27	CRC_MODE	<b>CRC Mode.</b> Effective immediately. This bit selects the CRC algorithm used to compute the signature. 0: $\text{nxt\_crc}[23:0] \leftarrow \{\text{crc}[22:0], (\text{crc}[23], \text{crc}[3], \text{crc}[2])\} \wedge \text{data}[23:0]$ . 1: $\text{nxt\_crc} = (\text{reset}) ? 32'h01 : (\{\text{crc}[30:0], 1'b0\} \wedge ((\text{crc}[31]) ? 32'h04c11db7 : 0)) \wedge \text{data}$ .
26	SGFR	<b>Signature Free Run.</b> Effective immediately. 0: Capture display signature for one frame. 1: Capture display signature continuously for multiple frames. When this bit is cleared, the signature accumulation stops at the end of the current frame.
25	SGRE	<b>Signature Read Enable.</b> Effective immediately. 0: Reads to DC_PAL_DATA (DC Memory Offset 074h[23:0]) return palette data. 1: Reads to DC_PAL_DATA (DC Memory Offset 074h[23:0]) return signature data. The palette address register contents are ignored in this case. Note that the automatic palette address increment mechanism will still operate even though the address is ignored.

## DC\_GENERAL\_CFG Bit Descriptions (Continued)

Bit	Name	Description
24	SIGE	<b>Signature Enable.</b> Effective immediately. 0: CRC Signature is reset to 000001h and held (no capture). 1: CRC Logic captures the pixel data signature with each pixel clock beginning with the next leading edge of vertical blank. Note that the CRC Logic treats each 24-bit pixel value as an autonomous 24-bit value (RGB color components are not captured separately in 8-bit signature registers).
23	SIG_SEL	<b>Signature Select.</b> Effective immediately. 1: Causes the CRC signature to be generated based on data being fed into the graphics scaling filter. This data stream does not include border/overscan pixels. 0: Clearing this bit allows bit 4 to select between the CRC calculation at the output of the scaler filter or the CRC signature based on the data being output from the DC, including border/overscan pixels. Also note that the CRC calculation can be affected by the VBI CRC enable bit, located in DC_VBI_EVEN_CTL (DC Memory Offset 0A0h[31]).
22	FRC8PIX	<b>Force 8-pixel Character Width.</b> When VGA mode is enabled, setting this bit forces the character width to be 8 pixels, overriding the setting in bit 0 (8-Dot character width) of the VGA's Sequencer Clocking Mode Register (index 01h). This causes the selection of an 8-pixel character width. This bit should be set for 640x480 flat panels when VGA fixed timing mode is enabled.
21	RSVD	<b>Reserved.</b> Always set to 0.
20	YUVM	<b>YUV Mode.</b> Selects YUV display mode for video overlay. 0: YUV 4:2:2 display mode. 1: YUV 4:2:0 display mode.
19	VDSE	<b>Video Downscale Enable.</b> 0: Send all video lines to the display filter. 1: Use DC_VID_DS_DELTA (DC Memory Offset 080h[31:18]) as a Digital Differential Analyzer (DDA) delta value to skip certain video lines to support downscaling in the display filter.
18	VGAFT	<b>VGA Fixed Timing.</b> When in VGA mode (VGAE bit 7 = 1), this bit indicates that the GLIU block (DC) timing generator should provide the display timings. The VGA will slave its display activity to the regular DC sync and display enable signals. The VGA image will be centered on the screen, but not scaled to fill the screen. If upscaling is desired, the scaler filter should be used instead of this feature. The final image must have at least six more active lines than the native VGA display settings indicate (i.e., at least three lines of border on the top and bottom of the image).
17	FDTY	<b>Frame Dirty Mode.</b> 0: Frame buffer writes mark associated scan line dirty. Used when FB_PITCH (DC Memory Offset 034h[15:0]) is equal to 1 KB, 2 KB, or 4 KB. 1: Frame buffer writes mark entire frame as dirty. Used when FB_PITCH (DC Memory Offset 034h[15:0]) is not equal to 1 KB, 2 KB, or 4 KB.
16	STFM	<b>Static Frame Mode.</b> When compression is enabled (CMPE bit 5 = 1), this bit controls the update of dirty scan lines. 0: Update dirty scan lines every frame. 1: Update dirty scan lines every other frame.
15:12	DFHPEL	<b>Display-FIFO High Priority End Level.</b> This field specifies the depth of the display FIFO (in multiples of 256 bytes) at which a high-priority request previously issued to the memory controller will end. The value is dependent upon display mode. This field should always be non-zero and should be larger than the start level. Note that the settings in the DC_ARB_CFG register (DC Memory Offset 00Ch) can also affect the priority of requests.

## DC\_GENERAL\_CFG Bit Descriptions (Continued)

Bit	Name	Description
11:8	DFHPSL	<b>Display-FIFO High Priority Start Level.</b> This field specifies the depth of the display FIFO (in multiples of 256 bytes) at which a high-priority request is sent to the memory controller to fill up the FIFO. The value is dependent upon display mode. This field should always be non-zero and should be less than the high-priority end level. Note that the settings in the DC_ARB_CFG register (DC Memory Offset 00Ch) can also affect the priority of requests.
7	VGAE	<b>VGA Enable.</b> When changing the state of this bit, both the DC and VGA should be stopped, and not actively fetching and displaying data.  No other DC features operate with the VGA pass-through feature enabled, with the exception of the CRC/signature feature, the filters, and the timing generator (when the filters or VGA fixed timings are enabled). All other features should be turned off to prevent interference with VGA operation.  0: Normal DC operation. 1: Allow the hardware VGA use of the display FIFO and the memory request interface. The VGA HSYNC, VSYNC, blank, and pixel outputs are routed through the back end of the DC pixel and sync pipeline and then to the I/O pads.
6	DECE	<b>Decompression Enable.</b> 0: Disable display refresh decompression. 1: Enable display refresh decompression.
5	CMPE	<b>Compression Enable.</b> 0: Disable display refresh compression. 1: Enable display refresh compression.
4	FILT_SIG_SEL	<b>Filter Signature Select.</b> When bit 23 is clear and this bit is set, the CRC mechanism at the output of the scaler filter (before the flicker filter) is enabled. Setting this bit when bit 23 is also set has no effect. When both this bit and bit 23 are cleared, the CRC is taken at the output of the DC, including the border/overscan pixels. Also note that the CRC calculation can be affected by the VBI CRC enable bit, located in DC_VBI_EVEN_CTL (DC Memory Offset 0A0h[31]).
3	VIDE	<b>Video Enable.</b> 0: Disable video port/overlay. 1: Enable video port/overlay.
2	CLR_CUR	<b>Color Cursor.</b> 0: 2-bpp format. 1: 32-bpp color cursor.
1	CURE	<b>Cursor Enable.</b> 0: Disable hardware cursor. 1: Enable hardware cursor.
0	DFLE	<b>Display-FIFO Load Enable.</b> 0: Disable display FIFO. 1: Enable display FIFO. Setting this bit high initiates display refresh requests to the memory controller at the trailing edge of vertical sync.

### 6.6.3.3 DC Display Configuration (DC\_DISPLAY\_CFG)

DC Memory Offset 008h

Type R/W

Reset Value 00000000h

This register contains configuration bits for controlling the various display functions of the DC.

Unless otherwise noted, settings written to this register do not take effect until the start of the following frame or interlaced field.

**DC\_DISPLAY\_CFG Register Map**

31	30	29	28	27	26	25	24	23	22	21	20	19	18	17	16	15	14	13	12	11	10	9	8	7	6	5	4	3	2	1	0
RSVD				VISL	RSVD	PALB	DCEN	RSVD				VFHPEL				VFHPSL				16BPP_MODE	DISP_MODE	RSVD	TRUP	RSVD	VLEN	GDEN	RSVD			TGEN	

**DC\_DISPLAY\_CFG Bit Descriptions**

Bit	Name	Description
31:28	RSVD	<b>Reserved.</b>
27	VISL	<b>Vertical Interrupt Select.</b> Effective immediately. 0: SMI generated at start of vertical blank when VIEN is enabled (bit 5 = 1). 1: SMI generated at end of vertical sync when VIEN is enabled (bit 5 = 1).
26	RSVD	<b>Reserved.</b>
25	PALB	<b>PAL Bypass.</b> 0: Graphics data is routed through palette RAM in 16, 24, and 32-bpp display modes. 1: Graphics data bypasses palette RAM in 16, 24, and 32-bpp display modes. While configured in this mode, 2-bpp cursor and border overlays are supported, but the palette entries for these items must be modified. See Section 6.6.7.1 on page 335 for more information.
24	DCEN	<b>Display Center.</b> 0: Normal active portion of scan line is qualified with DISPEN (ball AE4). 1: Border and active portions of scan line are qualified with DISPEN. This enables centering the display for flat panels.
23:20	RSVD	<b>Reserved.</b>
19:16	VFHPEL	<b>Video-FIFO High Priority End Level.</b> This field specifies the depth of the video FIFO (in multiples of 64 bytes) at which a high priority request previously issued to the memory controller for video data will end. This field should always be non-zero and should be larger than the start level. Note that the settings in the DC_ARB_CFG register (DC Memory Offset 00Ch) can also affect the priority of requests. This field should be set to 0 if video overlay is disabled.
15:12	VFHPSL	<b>Video-FIFO High Priority Start Level.</b> This field specifies the depth of the video FIFO (in multiples of 64 bytes) at which a high priority request is sent to the memory controller to fill up the video FIFO. This field should always be non-zero and should be less than the high-priority end level. Note that the settings in the DC_ARB_CFG register (DC Memory Offset 00Ch) can also affect the priority of requests.
11:10	16BPP_MODE	<b>Per-Pixel Mode.</b> Based on the number of bits per pixel (DISP_MODE bits [9:8] must equal 01), this determines how those bits are allocated to color and alpha information:  For 16-bpp display format: 00: 16-bpp (RGB 5:6:5) 01: 15-bpp (RGB 5:5:5) 10: XRGB (ARGB 4:4:4) 11: Reserved

**DC\_DISPLAY\_CFG Bit Descriptions (Continued)**

Bit	Name	Description
9:8	DISP_MODE	<b>Display Mode.</b> Bits per pixel. 00: 8-bpp (also used in VGA emulation) 01: 16-bpp 10: 24-bpp (RGB 8:8:8) 11: 32-bpp
7	RSVD	<b>Reserved.</b>
6	TRUP	<b>Timing Register Update.</b> Effective immediately. 0: Prevent update of working timing registers. This bit should be set low when a new timing set is being programmed, but the display is still running with the previously programmed timing set. 1: Update working timing registers on next active edge of vertical sync.
5	RSVD	<b>Reserved.</b>
4	VDEN	<b>Video Data Enable.</b> Set this bit to 1 to allow transfer of video data to the VP.
3	GDEN	<b>Graphics Data Enable.</b> Set this bit to 1 to allow transfer of graphics data through the display pipeline.
2:1	RSVD	<b>Reserved.</b>
0	TGEN	<b>Timing Generator Enable.</b> Effective immediately. 0: Disable timing generator. 1: Enable timing generator.  This bit must be set to 0 when using VGA mode unless the filters or VGA Fixed Timings are also enabled (DC_GENERAL_CFG register, bit 18, DC Memory Offset 004h[18]).

### 6.6.3.4 DC Arbitration Configuration (DC\_ARB\_CFG)

DC Memory Offset 00Ch  
 Type R/W  
 Reset Value 00000000h

This register contains configuration bits for controlling the priority level of GLIU requests by the DC. It allows high priority to be enabled under several conditions (see bits [8:1]). These conditions are ORed with other sources of high-priority, including the FIFO watermark mechanisms. Settings written to this register take effect immediately. The features in this register do not affect the DC's internal prioritization of video vs. graphics data fetches -- just the priority that is presented on the GeodeLink request. The low priority at VSYNC mechanism (bits [15:9, 0]) takes precedence over all priority mechanisms except the high priority when line buffer fill in progress" mechanism bit [1].

**DC\_ARB\_CFG Register Map**

31	30	29	28	27	26	25	24	23	22	21	20	19	18	17	16	15	14	13	12	11	10	9	8	7	6	5	4	3	2	1	0
RSVD											LB_LOAD_WM_EN	LB_LOAD_WM	LPEN_END_COUNT										HPEN_SB_INV	HPEN_FB_INV_HALFBS	HPEN_FB_INV_SBRD	HPEN_FB_INV	HPEN_1LB_INV	HPEN_2LB_INV	HPEN_3LB_INV	HPEN_LB_FILL	LPEN_VSYNC

**DC\_ARB\_CFG Bit Descriptions**

Bit	Name	Description
31:21	RSVD	<b>Reserved.</b>
20	LB_LOAD_WM_EN	<b>Line Buffer Load Watermark Enable.</b> When set, allows line buffer loads from the display FIFO to begin when the display FIFO has at least as much data as defined by the watermark in bits [19:16] (LB_LOAD_WM). When this bit is cleared, line buffer loads are not permitted until the display FIFO is full.
19:16	LB_LOAD_WM	<b>Line Buffer Load Watermark.</b> When enabled via bit 20 (LB_LOAD_WM_EN), this watermark determines how much data must be in the DFIFO before a line buffer load is permitted. This level is set in 256-byte increments.
15:9	LPEN_END_COUNT	<b>Low Priority End Counter.</b> When bit 0 (LPEN_VSYNC) is set, this field indicates the number of scan lines after VSYNC that the DC will force its requests to low priority. Because the line buffers, flicker filter buffers, sync buffer, and data FIFO are all cleared at VSYNC, this mechanism prevents the DC from spending an inordinate amount of time in high priority while filling all of these buffers. In most cases this value should be set three or four lines less than the distance between VSYNC start and V_TOTAL. This value may need to be lowered if VBI data is enabled.
8	HPEN_SB_INV	<b>High Priority Enable when Sync Buffer Invalid.</b> This bit enables the DC to arbitrate in high priority whenever the synchronizer buffer does not contain valid data.
7	HPEN_FB_INV_HALFBS	<b>High Priority Enable when Flicker Buffer invalid and Sync Buffer less than Half Full.</b> This bit enables the DC to arbitrate in high priority whenever the synchronizer buffer is less than half full and the flicker filter buffer does not contain valid data.
6	HPEN_FB_INV_SBRD	<b>High Priority Enable when Flicker Buffer invalid and Sync Buffer Being Read.</b> This bit enables the DC to arbitrate in high priority whenever the synchronizer buffer is being read and the flicker filter buffer does not contain valid data.
5	HPEN_FB_INV	<b>High Priority Enable when Flicker Buffer Invalid.</b> This bit enables the DC to arbitrate at high priority whenever the flicker filter buffer does not contain valid data.
4	HPEN_1LB_INV	<b>High Priority Enable when Any One Line Buffer Invalid.</b> This bit enables the DC to arbitrate at high priority if any of the three line buffers is invalid. (When the scaler filter is disabled, only one logical line buffer is used, and the state of the others is ignored.)

## DC\_ARB\_CFG Bit Descriptions (Continued)

Bit	Name	Description
3	HPEN_2LB_INV	<b>High Priority Enable when Any Two Line Buffers Invalid.</b> This bit enables the DC to arbitrate at high priority if the scaler filter is enabled and any two of the three line buffers that feed this filter are invalid. (The state of this bit is ignored if the scaler filter is disabled.)
2	HPEN_3LB_INV	<b>High Priority Enable when Any Three Line Buffers Invalid.</b> This bit enables the DC to arbitrate at high priority if the scaler filter is enabled and all of the three line buffers that feed this filter are invalid. (The state of this bit is ignored if the scaler filter is disabled.)
1	HPEN_LB_FILL	<b>High Priority Enable when Line Buffer Fill in Progress.</b> This bit enables the DC to maintain high priority requests whenever it is in the process of filling a line buffer. The line buffer fill requires an entire scan line of data to be read from the data FIFO without interruption. Because the FIFO typically does not contain a full scan line of data, it is necessary to fetch additional data from memory during this process.
0	LPEN_VSYNC	<b>Low Priority Enable at VSYNC.</b> When this bit is set, the DC is forced to arbitrate at low priority for a number of lines after the start of VSYNC. (This number of lines is programmed in bits [15:9] (LPEN_END_COUNT)) Because the line buffers, flicker filter buffers, sync buffer, and data FIFO are all cleared at VSYNC, this mechanism prevents the DC from spending an inordinate amount of time in high priority while filling all of these buffers.  In most cases this value should be set three or four lines less than the distance between VSYNC start and V_TOTAL. This value may need to be lowered if VBI data is enabled.  During this low priority period after VSYNC, this mechanism overrides the watermark mechanism for the data FIFO and all of the other mechanisms in this register except the high priority enable when line buffer fill in progress mechanism enabled in bit 1 (HPEN_LB_FILL). Outside of this period, this mechanism has no effect on the priority level of outgoing DC requests on the GLIU.



### 6.6.4 Memory Organization Registers

The graphics memory region is up to 16 MB in size. The graphics memory is made up of the normal uncompressed frame buffer, compressed display buffer, cursor buffer, cursor color buffer (for 16-bit color cursor), and video buffer(s). Each buffer begins at a programmable offset within the graphics memory region.

The various memory buffers are arranged so as to efficiently pack the data within the graphics memory region. This requires flexibility in the way that the buffers are arranged when different display modes are in use. The cursor and cursor color buffers are linear blocks, so addressing is straightforward. The frame buffer and compressed display buffer are arranged based upon scan lines. Each scan line has a maximum number of valid or active QWORDS and a pitch that, when added to the previous line offset, points to the next line. In this way, the buffers may be stored as linear blocks or as rectangular blocks.

The various buffers' addresses are all located within the same 1 MB-aligned region. Thus, a separate register, DC\_GLIU0\_MEM\_OFFSET (DC Memory Offset 084h), is used to set a 1 MB-aligned base address.

GART address translation is not supported.

#### 6.6.4.1 DC Frame Buffer Start Address (DC\_FB\_ST\_OFFSET)

DC Memory Offset 010h

Type R/W

Reset Value xxxxxxxxh

This register specifies the offset at which the frame buffer starts. Settings written to this register do not take effect until the start of the following frame or interlaced field.

#### DC\_FB\_ST\_OFFSET

31	30	29	28	27	26	25	24	23	22	21	20	19	18	17	16	15	14	13	12	11	10	9	8	7	6	5	4	3	2	1	0
RSVD				OFFSET																											

#### DC\_FB\_ST\_OFFSET Bit Descriptions

Bit	Name	Description
31:28	RSVD	<b>Reserved.</b>
27:0	OFFSET	<p><b>Frame Buffer Start Offset.</b> This value represents the byte offset of the starting location of the displayed frame buffer. This value may be changed to achieve panning across a virtual desktop or to allow multiple buffering.</p> <p>When this register is programmed to a non-zero value, the compression logic should be disabled. The memory address defined by bits [27:3] takes effect at the start of the next frame scan. The pixel offset defined by bits [2:0] is latched at the end of vertical sync and added to the pixel panning offset to determine the actual panning value.</p>

#### 6.6.4.2 DC Compression Buffer Start Address (DC\_CB\_ST\_OFFSET)

DC Memory Offset 014h

Type R/W

Reset Value xxxxxxxxh

This register specifies the offset at which the compressed display buffer starts. Settings written to this register do not take effect until the start of the following frame or interlaced field.

#### DC\_CB\_ST\_OFFSET Register Map

31	30	29	28	27	26	25	24	23	22	21	20	19	18	17	16	15	14	13	12	11	10	9	8	7	6	5	4	3	2	1	0
RSVD				OFFSET																								0h			

#### DC\_CB\_ST\_OFFSET Bit Descriptions

Bit	Name	Description
31:28	RSVD	<b>Reserved.</b>
27:0	OFFSET	<b>Compressed Display Buffer Start Offset.</b> This value represents the byte offset of the starting location of the compressed display buffer. The lower five bits should always be programmed to zero so that the start offset is aligned to a 32-byte boundary. This value should change only when a new display mode is set due to a change in size of the frame buffer.

#### 6.6.4.3 DC Cursor Buffer Start Address (DC\_CURS\_ST\_OFFSET)

DC Memory Offset 018h

Type R/W

Reset Value xxxxxxxxh

This register specifies the offset at which the cursor memory buffer starts. Settings written to this register do not take effect until the start of the following frame or interlaced field.

#### DC\_CURS\_ST\_OFFSET Register Map

31	30	29	28	27	26	25	24	23	22	21	20	19	18	17	16	15	14	13	12	11	10	9	8	7	6	5	4	3	2	1	0
RSVD				OFFSET																								0h			

#### DC\_CURS\_ST\_OFFSET Bit Descriptions

Bit	Name	Description
31:28	RSVD	<b>Reserved.</b>
27:0	OFFSET	<b>Cursor Start Offset.</b> This value represents the byte offset of the starting location of the cursor display pattern. The lower five bits should always be programmed to zero so that the start offset is 32-byte aligned. Note that if there is a Y offset for the cursor pattern, the cursor start offset should be set to point to the first displayed line of the cursor pattern.

**6.6.4.4 DC Video Y Buffer Start Address Offset (DC\_VID\_Y\_ST\_OFFSET)**

DC Memory Offset 020h

Type R/W

Reset Value xxxxxxxxh

This register specifies the offset at which the video Y (YUV 4:2:0) or YUV (YUV 4:2:2) buffer starts.

The upper 4 bits of this register are for the field count mechanism. This mechanism, which did not exist on previous AMD Geode processors, allows the DC to fetch multiple fields or frames of VIP data without requiring software intervention to move the offset. This mechanism has the constraint that the buffers for multiple video frames must be contiguous in memory. (The VIP hardware will meet this constraint.)

Settings written to this register do not take effect until the start of the following frame or interlaced field.

**DC\_VID\_Y\_ST\_OFFSET Register Map**

31	30	29	28	27	26	25	24	23	22	21	20	19	18	17	16	15	14	13	12	11	10	9	8	7	6	5	4	3	2	1	0
RSVD				OFFSET																								0h			

**DC\_VID\_Y\_ST\_OFFSET Bit Descriptions**

Bit	Name	Description
31:28	RSVD	<b>Reserved.</b> Reserved for field count mechanism
27:0	OFFSET	<b>Video Y Buffer Start Offset.</b> This value represents the starting location for Video Y Buffer. The lower five bits should always be programmed as zero so that the start offset is aligned to a 32-byte boundary. If YUV 4:2:2 mode is selected (DC Memory Offset 004h[20] = 0), the Video Y Buffer is used as a singular buffer holding interleaved Y, U and V data. If YUV 4:2:0 is selected (DC Memory Offset 004h[20] = 1), the Video Y Buffer is used to hold only Y data while U and V data are stored in separate buffers whose start offsets are represented in DC_VID_U_ST_OFFSET (DC Memory Offset 024h[27:0]) and DC_VID_V_ST_OFFSET (DC Memory Offset 028h[27:0]).

**6.6.4.5 DC Video U Buffer Start Address Offset (DC\_VID\_U\_ST\_OFFSET)**

DC Memory Offset 024h

Type R/W

Reset Value xxxxxxxxh

This register specifies the offset at which the video U (YUV 4:2:0) buffer starts.

Settings written to this register do not take effect until the start of the following frame or interlaced field.

**DC\_VID\_U\_ST\_OFFSET Register Map**

31	30	29	28	27	26	25	24	23	22	21	20	19	18	17	16	15	14	13	12	11	10	9	8	7	6	5	4	3	2	1	0
FRAME_COUNT				OFFSET																								0			

## DC\_VID\_U\_ST\_OFFSET Bit Descriptions

Bit	Name	Description
31:28	FRAME_COUNT	<b>Frame Count.</b> When reading this register, this field indicates the current frame count, as determined by counting rising edges of VIP VSYNC. This value is reset to 0 when VIP_VSYNC occurs and FRAME_CNT >= FRAME_LIMIT. It can also be written to provide a mechanism for software to synchronize activities between the VIP and the Display Controller. However, this can result in corrupted video data until the next reset of this counter.
27:0	OFFSET	<b>Video U Buffer Start Offset.</b> This value represents the starting location for the Video U Buffer. The lower three bits should always be programmed as zero so that the start offset is aligned to a QWORD boundary. A buffer for U data is only used if YUV 4:2:0 display mode is selected (DC Memory Offset 004h[20] = 1).

## 6.6.4.6 DC Video V Buffer Start Address Offset (DC\_VID\_V\_ST\_OFFSET)

DC Memory Offset 028h

Type R/W

Reset Value xxxxxxxxh

This register specifies the offset at which the video V buffer starts.

Settings written to this register do not take effect until the start of the following frame or interlaced field.

## DC\_VID\_V\_ST\_OFFSET Register Map

31	30	29	28	27	26	25	24	23	22	21	20	19	18	17	16	15	14	13	12	11	10	9	8	7	6	5	4	3	2	1	0
RSVD				OFFSET													0														

## DC\_VID\_V\_ST\_OFFSET Bit Descriptions

Bit	Name	Description
31:28	RSVD	<b>Reserved.</b>
27:0	OFFSET	<b>Video V Buffer Start Offset.</b> This value represents the starting location for the Video V Buffer. The lower three bits should always be programmed as zero so that the start offset is aligned to a QWORD boundary. A buffer for V data is only used if YUV 4:2:0 display mode is selected (DC Memory Offset 004h[20] = 1).

## 6.6.4.7 DC Dirty/Valid Region Top (DC\_DV\_TOP)

DC Memory Offset 02Ch

Type R/W

Reset Value 00000000h

This register specifies the top of the frame buffer memory region to be watched for frame-dirty mode.

Settings written to this register take effect immediately.

## DC\_DV\_TOP Register Map

31	30	29	28	27	26	25	24	23	22	21	20	19	18	17	16	15	14	13	12	11	10	9	8	7	6	5	4	3	2	1	0
RSVD								DV_TOP														RSVD				DV_TOP_EN					

## DC\_DV\_TOP Bit Descriptions

Bit	Name	Description
31:24	RSVD	<b>Reserved.</b> These bits should be programmed to zero.
23:10	DV_TOP_ADDR	<b>Dirty/Valid Region Top Address.</b> When enabled via bit 0 (DV_TOP_EN), this field indicates the size of the region to be watched for frame buffer accesses. When writes to this region occur and the compression logic is in frame-dirty mode, the frame is marked as dirty. (Writes outside this region, regardless of the settings in the DV_CTL register (DC Memory Offset 088h), do not cause the frame to be marked as dirty in frame-dirty mode.) The bits in this field correspond to address bits [23:10].
9:1	RSVD	<b>Reserved.</b> These bits should be programmed to zero.
0	DV_TOP_EN	<b>Dirty/Valid Region Top Enable.</b> This bit enables the top-of-region check for frame-dirty mode. This bit should be cleared if the compression logic is NOT configured for frame-dirty mode.

## 6.6.4.8 DC Line Size (DC\_LINE\_SIZE)

DC Memory Offset 030h

Type R/W

Reset Value xxxxxxxxh

This register specifies the number of bytes to transfer for a line of frame buffer, compression buffer, and video buffer data. The compressed line buffer is invalidated if it exceeds the CB\_LINE\_SIZE (bits [18:12]).

Settings written to this register do not take effect until the start of the following frame or interlaced field.

## DC\_LINE\_SIZE Register Map

31	30	29	28	27	26	25	24	23	22	21	20	19	18	17	16	15	14	13	12	11	10	9	8	7	6	5	4	3	2	1	0
RSVD	VID_LINE_SIZE											RSVD	CB_LINE_SIZE					RSVD	FB_LINE_SIZE												

## DC\_LINE\_SIZE Bit Descriptions

Bit	Name	Description
31:30	RSVD	<b>Reserved.</b> These bits should be programmed to zero.
29:20	VID_LINE_SIZE	<b>Video Line Size.</b> This value specifies the number of QWORDS (8-byte segments) to transfer for each source line from the video buffer in YUV 4:2:2 mode. In YUV 4:2:0 mode, it specifies the number of QWORDS to transfer for the U or V stream for a source line (2x this amount is transferred for the Y stream). In YUV 4:2:2 mode, this field must be set to a multiple of four QWORDS -- bits [21:20] must be 0.
19	RSVD	<b>Reserved.</b> This bit should be programmed to zero.
18:12	CB_LINE_SIZE	<b>Compressed Display Buffer Line Size.</b> This value represents the number of QWORDS for a valid compressed line plus 1. It is used to detect an overflow of the compressed data FIFO. When the compression data for a line reaches CB_LINE_SIZE QWORDS, the line is deemed incompressible. Note that DC actually writes CB_LINE_SIZE + 4 QWORDS to memory, so if X QWORDS are allocated for each compression line, then X - 4 + 1 (or X - 3) should be programmed into this register. Note also that the CB_LINE_SIZE field should never be larger than 65 (041h) since the maximum size of the compressed data FIFO is 64 QWORDS.
11:10	RSVD	<b>Reserved.</b> These bits should be programmed to zero.
9:0	FB_LINE_SIZE	<b>Frame Buffer Line Size.</b> This value specifies the number of QWORDS (8-byte segments) to transfer for each display line from the frame buffer.

**6.6.4.9 DC Graphics Pitch (DC\_GFX\_PITCH)**

DC Memory Offset 034h

Type R/W

Reset Value xxxxxxxxh

This register stores the pitch for the graphics display buffers.

**DC\_GFX\_PITCH Register Map**

31	30	29	28	27	26	25	24	23	22	21	20	19	18	17	16	15	14	13	12	11	10	9	8	7	6	5	4	3	2	1	0
CB_PITCH																FB_PITCH															

**DC\_GFX\_PITCH Bit Descriptions**

Bit	Name	Description
31:16	CB_PITCH	<b>Compressed Display Buffer Pitch.</b> This value represents the number of QWORDS between consecutive scan lines of compressed buffer data in memory. This pitch must be set to a multiple of four QWORDS (i.e., bits [17:16] must be 00).
15:0	FB_PITCH	<b>Frame Buffer Pitch.</b> This value represents the number of QWORDS between consecutive scan lines of frame buffer data in memory.

**6.6.4.10 DC Video YUV Pitch (DC\_VID\_YUV\_PITCH)**

DC Memory Offset 038h

Type R/W

Reset Value xxxxxxxxh

This register stores the pitch for the video buffers.

**DC\_VID\_YUV\_PITCH Register Map**

31	30	29	28	27	26	25	24	23	22	21	20	19	18	17	16	15	14	13	12	11	10	9	8	7	6	5	4	3	2	1	0
UV_PITCH																Y_PITCH															

**DC\_VID\_YUV\_PITCH Bit Descriptions**

Bit	Name	Description
31:16	UV_PITCH	<b>Video U and V Buffer Pitch.</b> This value represents the number of QWORDS between consecutive scan lines of U or V buffer data in memory. (U and V video buffers are always the same pitch.) A pitch up to 512 KB is supported to allow for vertical decimation for downscaling.
15:0	Y_PITCH	<b>Video Y Buffer Pitch.</b> This value represents the number of QWORDS between consecutive scan lines of Y buffer data in memory. A pitch up to 512 KB is supported to allow for vertical decimation for downscaling.

### 6.6.5 Timing Registers

The DC timing registers control the generation of sync, blanking, and active display regions. These registers are generally programmed by the BIOS from an INT 10h call or by the extended mode driver from a display timing file.

Example: To display a 1024x768 graphics (frame buffer) image on a 720x483/59.94 television. The DC CRTIC settings are as follows:

```
DC_H_ACTIVE_TIMING (040h) = 0x035A_02D0 // h_total = 858; h_active = 720
DC_H_BLANK_TIMING (044h) = 0x35A_02D0 // h_blank_start = 720; h_blank_end=858 -- no overscan
DC_H_SYNC_TIMING (048h) = 0x031F_02E0 // h_sync_start = 736; h_sync_end = 799
DC_V_ACTIVE_TIMING (050h) = 0x0106_00F1 // v_total = 262 (even) 263(odd); v_active = 241 (even & odd)
DC_V_BLANK_TIMING (054h) = 0x0106_00F1 // v_blank_start = 241; v_blank_end = 262 -- no overscan
DC_V_SYNC_TIMING (058h) = 0x00F6_00F5 // v_sync_start = 245; vsync_end = 246
DC_V_ACTIVE_EVEN_TIMING (0E4h) = // v_total = 261; v_active = 240
0x0105_00F0
DC_V_BLANK_EVEN_TIMING (0E8h) = // v_blank_start = 240; v_blank_end = 261
0x0105_00F0
DC_V_SYNC_EVEN_TIMING (0ECh) = 0x00F6_00F5 // v_sync_start = 245; v_sync_end = 246
DC_B_ACTIVE (05Ch) = 03FF_02FFh // frame buffer size1024x768
```

**Note:** The above timings are based on tables B.1 and B.2 in the ANSI/SMTPE 293M-1996 spec. They assume that the frame buffer image should be displayed over the entire 720x483 screen, with no additional border.

The DC\_GFX\_SCALE (DC Memory Offset 090h) register would be set up to scale the 1024x768 image to a 720x483 frame:

$v\_scale = (768/(483-1)) = 1.593360995\dots$

$h\_scale = (1024/(720 - 1)) = 1.424200278\dots$

DC\_GFX\_SCALE = 65F9\_5B26h

( $v\_scale = 1.593322754$ ;  $h\_scale = 1.424194336$ )

In addition, the FILT\_ENA and INTL\_EN bits would be set (DC Memory Offset 94h[12,11] = 11), and the filter coefficients would be programmed. This example also presumes that the FLICK\_EN bit is set (DC Memory Offset 0D4h[24] = 1).

Because the output is to be interlaced, the flicker filter can be used. (Use of the flicker filter is not required.) For information on the configuration bits for the flicker filter, see "DC GenLock Control (DC\_GENLK\_CTL)" on page 350.

### 6.6.5.1 DC Horizontal and Total Timing (DC\_H\_ACTIVE\_TIMING)

DC Memory Offset 040h

Type R/W

Reset Value xxxxxxxxh

This register contains horizontal active and total timing information.

#### DC\_H\_ACTIVE\_TIMING Register Map

31	30	29	28	27	26	25	24	23	22	21	20	19	18	17	16	15	14	13	12	11	10	9	8	7	6	5	4	3	2	1	0
RSVD				H_TOTAL												RSVD				H_ACTIVE											

#### DC\_H\_ACTIVE\_TIMING Bit Descriptions

Bit	Name	Description
31:28	RSVD	<b>Reserved.</b> These bits should be programmed to zero.
27:16	H_TOTAL	<b>Horizontal Total.</b> This field represents the total number of pixel clocks for a given scan line minus 1. Note that the value must represent a value greater than the H_ACTIVE field (bits [11:0]) because it includes border pixels and blanked pixels. For flat panels, this value will never change. Unlike previous versions of the DC, the horizontal total can be programmed to any pixel granularity; it is <b>not</b> limited to character (8-pixel) granularity.
15:12	RSVD	<b>Reserved.</b> These bits should be programmed to zero.
11:0	H_ACTIVE	<b>Horizontal Active.</b> This field represents the total number of pixel clocks for the displayed portion of a scan line minus 1. Note that for flat panels, if this value is less than the panel active horizontal resolution (H_PANEL), the parameters H_BLK_START, H_BLK_END (DC Memory Offset 044h[11:0, 27:16]), H_SYNC_ST, and H_SYNC_END (DC Memory Offset 048h[11:0, 27:16]) should be reduced by the value of H_ADJUST (or the value of H_PANEL - H_ACTIVE / 2) to achieve horizontal centering.  Unlike previous versions of the DC, this field can be programmed to any pixel granularity; it is <b>not</b> limited to character (8-pixel) granularity.  If graphics scaling is enabled, this value represents the width of the final (scaled) image to be displayed. The width of the frame buffer image may be different in this case; DC_FB_ACTIVE (DC Memory Offset 05Ch) is used to program the horizontal and vertical active values in the frame buffer when graphics scaling is enabled.  H_ACTIVE must be set to at least 64 pixels.



**6.6.5.2 DC CRT Horizontal Blanking Timing (DC\_H\_BLANK\_TIMING)**

DC Memory Offset 044h

Type R/W

Reset Value xxxxxxxxh

This register contains CRT horizontal blank timing information.

**Note:** A minimum of 32 pixel clocks is required for the horizontal blanking portion of a line in order for the timing generator to function correctly.

**DC\_H\_BLANK\_TIMING Register Map**

31	30	29	28	27	26	25	24	23	22	21	20	19	18	17	16	15	14	13	12	11	10	9	8	7	6	5	4	3	2	1	0
RSVD				H_BLK_END												RSVD				H_BLK_START											

**DC\_H\_BLANK\_TIMING Bit Descriptions**

Bit	Name	Description
31:28	RSVD	<b>Reserved.</b> These bits should be programmed to zero.
27:16	H_BLK_END	<b>Horizontal Blank End.</b> This field represents the pixel clock count at which the horizontal blanking signal becomes inactive minus 1.  Unlike previous versions of the DC, this field can be programmed to any pixel granularity; it is <b>not</b> limited to character (8-pixel) granularity.
15:12	RSVD	<b>Reserved.</b> These bits should be programmed to zero.
11:0	H_BLK_START	<b>Horizontal Blank Start.</b> This field represents the pixel clock count at which the horizontal blanking signal becomes active minus 1.  Unlike previous versions of the DC, this field can be programmed to any pixel granularity; it is <b>not</b> limited to character (8-pixel) granularity.

**6.6.5.3 DC CRT Horizontal Sync Timing (DC\_H\_SYNC\_TIMING)**

DC Memory Offset 048h

Type R/W

Reset Value xxxxxxxxh

This register contains CRT horizontal sync timing information. Note however, that this register should also be programmed appropriately for flat panel only display, since the horizontal sync transition determines when to advance the vertical counter.

**DC\_H\_SYNC\_TIMING Register Map**

31	30	29	28	27	26	25	24	23	22	21	20	19	18	17	16	15	14	13	12	11	10	9	8	7	6	5	4	3	2	1	0
RSVD				H_SYNC_END												RSVD				H_SYNC_ST											

**DC\_H\_SYNC\_TIMING Bit Descriptions**

Bit	Name	Description
31:28	RSVD	<b>Reserved.</b> These bits should be programmed to zero.
27:16	H_SYNC_END	<b>Horizontal Sync End.</b> This field represents the pixel clock count at which the CRT horizontal sync signal becomes inactive minus 1.  Unlike previous versions of the DC, this field can be programmed to any pixel granularity; it is <b>not</b> limited to character (8-pixel) granularity.  The horizontal sync must be at least 8 pixels in width.

## DC\_H\_SYNC\_TIMING Bit Descriptions

Bit	Name	Description
15:12	RSVD	<b>Reserved.</b> These bits should be programmed to zero.
11:0	H_SYNC_ST	<p><b>Horizontal Sync Start.</b> This field represents the pixel clock count at which the CRT horizontal sync signal becomes active minus 1.</p> <p>Unlike previous versions of the DC, this field can be programmed to any pixel granularity; it is <i>not</i> limited to character (8-pixel) granularity.</p> <p>The horizontal sync must be at least 8 pixels in width, and cannot begin until at least 8 pixels after H_BLK_START (DC Memory Offset 044h[11:0]).</p>

## 6.6.5.4 DC Vertical and Total Timing (DC\_V\_ACTIVE\_TIMING)

DC Memory Offset 050h

Type R/W

Reset Value xxxxxxxxh

This register contains vertical active and total timing information. The parameters pertain to both CRT and flat panel display. All values are specified in lines.

## DC\_V\_ACTIVE\_TIMING Register Map

31	30	29	28	27	26	25	24	23	22	21	20	19	18	17	16	15	14	13	12	11	10	9	8	7	6	5	4	3	2	1	0
RSVD				V_TOTAL								RSVD				V_ACTIVE															

## DC\_V\_ACTIVE\_TIMING Bit Descriptions

Bit	Name	Description
31:27	RSVD	<b>Reserved.</b> These bits should be programmed to zero.
26:16	V_TOTAL	<p><b>Vertical Total.</b> This field represents the total number of lines for a given frame scan minus 1. Note that the value is necessarily greater than the V_ACTIVE field (bits [10:0]) because it includes border lines and blanked lines. If the display is interlaced, the total number of lines must be odd, so this value should be an even number.</p>
15:11	RSVD	<b>Reserved.</b> These bits should be programmed to zero.
10:0	V_ACTIVE	<p><b>Vertical Active.</b> This field represents the total number of lines for the displayed portion of a frame scan minus 1. Note that for flat panels, if this value is less than the panel active vertical resolution (V_PANEL), the parameters V_BLANK_START, V_BLANK_END (DC Memory Offset 054h[10:0, 26:16]), V_SYNC_START, and V_SYNC_END (DC Memory Offset 058h[10:0, 26:16]) should be reduced by the following value (V_ADJUST) to achieve vertical centering:</p> $V\_ADJUST = (V\_PANEL - V\_ACTIVE) / 2$ <p>If the display is interlaced, the number of active lines should be even, so this value should be an odd number.</p> <p>If graphics scaling is enabled (and interleaved display is disabled), this value represents the height of the final (scaled) image to be displayed. The height of the frame buffer image may be different in this case; DC_FB_ACTIVE (DC Memory Offset 05Ch) is used to program the horizontal and vertical active values in the frame buffer when graphics scaling is enabled.</p> <p>If interleaved mode is enabled, this value represents half the height of the final (scaled and interleaved) displayed image.</p>

**6.6.5.5 DC CRT Vertical Blank Timing (DC\_V\_BLANK\_TIMING)**

DC Memory Offset 054h

Type R/W

Reset Value xxxxxxxxh

This register contains vertical blank timing information. All values are specified in lines. For interlaced display, no border is supported, so blank timing is implied by the total/active timing.

**DC\_V\_BLANK\_TIMING Register Map**

31	30	29	28	27	26	25	24	23	22	21	20	19	18	17	16	15	14	13	12	11	10	9	8	7	6	5	4	3	2	1	0
RSVD				V_BLANK_END												RSVD				V_BLANK_START											

**DC\_V\_BLANK\_TIMING Bit Descriptions**

Bit	Name	Description
31:27	RSVD	<b>Reserved.</b> These bits should be programmed to zero.
26:16	V_BLANK_END	<b>Vertical Blank End.</b> This field represents the line at which the vertical blanking signal becomes inactive minus 1. If the display is interlaced, no border is supported, so this value should be identical to V_TOTAL.
15:11	RSVD	<b>Reserved.</b> These bits should be programmed to zero.
10:0	V_BLANK_START	<b>Vertical Blank Start.</b> This field represents the line at which the vertical blanking signal becomes active minus 1. If the display is interlaced, this value should be programmed to V_ACTIVE plus 1.

**6.6.5.6 DC CRT Vertical Sync Timing (DC\_V\_SYNC\_TIMING)**

DC Memory Offset 058h

Type R/W

Reset Value xxxxxxxxh

This register contains CRT vertical sync timing information. All values are specified in lines.

**DC\_V\_SYNC\_TIMING Register Map**

31	30	29	28	27	26	25	24	23	22	21	20	19	18	17	16	15	14	13	12	11	10	9	8	7	6	5	4	3	2	1	0
RSVD				V_SYNC_END												RSVD				V_SYNC_START											

**DC\_V\_SYNC\_TIMING Bit Descriptions**

Bit	Name	Description
31:27	RSVD	<b>Reserved.</b> These bits should be programmed to zero.
26:16	V_SYNC_END	<b>Vertical Sync End.</b> This field represents the line at which the CRT vertical sync signal becomes inactive minus 1.
15:11	RSVD	<b>Reserved.</b> These bits should be programmed to zero.
10:0	V_SYNC_START	<b>Vertical Sync Start.</b> This field represents the line at which the CRT vertical sync signal becomes active minus 1. For interlaced display, note that the vertical counter is incremented twice during each line and since there are an odd number of lines, the vertical sync pulse will trigger in the middle of a line for one field and at the end of a line for the subsequent field.

### 6.6.5.7 DC Frame Buffer Active Region Register (DC\_FB\_ACTIVE)

DC Memory Offset 05Ch

Type R/W

Reset Value xxxxxxxxh

#### DC\_FB\_ACTIVE Register Map

31	30	29	28	27	26	25	24	23	22	21	20	19	18	17	16	15	14	13	12	11	10	9	8	7	6	5	4	3	2	1	0
FB_H_ACTIVE																FB_V_ACTIVE															

#### DC\_FB\_ACTIVE Bit Descriptions

Bit	Name	Description
31:16	FB_H_ACTIVE	<p><b>Horizontal Frame Buffer Active End.</b> This field is used only when graphics scaling is enabled. The lower three bits of this register are ignored and presumed to be 111. Including these bits, the value in this field represents the total number of pixels in a line in the graphics frame buffer minus 1.</p> <p>This field is analogous to the H_ACTIVE field in the DC_H_ACTIVE_TIMING register (DC Memory Offset 040h[11:0]), except that this field is used only for the fetching and rendering of pixel data, not the display timings. When graphics scaling is disabled, this field is not used. (The H_ACTIVE field is used instead.)</p>
15:0	FB_V_ACTIVE	<p><b>Vertical Frame Buffer Active.</b> This field is used only when graphics scaling is enabled. It represents the total number of lines in the graphics frame buffer minus 1.</p> <p>This field is analogous to the V_ACTIVE field in the DC_V_ACTIVE_TIMING register (DC Memory Offset 050h[10:0]), except that this field is used only for the fetching and rendering of pixel data, not the display timings. When graphics scaling is disabled, this field is not used. (The V_ACTIVE field is used instead.)</p>

### 6.6.6 Cursor Position and Line Count/Status Registers

The cursor registers contain pixel coordinate information for the cursor. These values are not latched by the timing generator until the start of the frame to avoid tearing artifacts when moving the cursor.

The Line Count/Status register holds status information for the current display status, including the current scan line for the display.

#### 6.6.6.1 DC Cursor X Position (DC\_CURSOR\_X)

DC Memory Offset 060h

Type R/W

Reset Value xxxxxxxxh

This register contains the X position information of the hardware cursor.

Settings written to this register do not take effect until the start of the following frame or interlaced field.

#### DC\_CURSOR\_X Register Map

31	30	29	28	27	26	25	24	23	22	21	20	19	18	17	16	15	14	13	12	11	10	9	8	7	6	5	4	3	2	1	0
RSVD																X_OFFSET						CURSOR_X									

#### DC\_CURSOR\_X Bit Descriptions

Bit	Name	Description
31:17	RSVD	Reserved.

## DC\_CURSOR\_X Bit Descriptions

Bit	Name	Description
16:11	X_OFFSET	<b>X Offset.</b> This field represents the X pixel offset within the 64x64 cursor pattern at which the displayed portion of the cursor is to begin. Normally, this value is set to zero to display the entire cursor pattern, but for cursors for which the “hot spot” is not at the left edge of the pattern, it may be necessary to display the right-most pixels of the cursor only as the cursor moves close to the left edge of the display.
10:0	CURSOR_X	<b>Cursor X.</b> This field represents the X coordinate of the pixel at which the upper left corner of the cursor is to be displayed. This value is referenced to the screen origin (0,0), which is the pixel in the upper left corner of the screen.

## 6.6.6.2 DC Cursor Y Position (DC\_CURSOR\_Y)

DC Memory Offset 064h

Type R/W

Reset Value xxxxxxxxh

This register contains the Y position information of the hardware cursor.

Settings written to this register will not take effect until the start of the following frame or interlaced field.

## DC\_CURSOR\_Y Register Map

31	30	29	28	27	26	25	24	23	22	21	20	19	18	17	16	15	14	13	12	11	10	9	8	7	6	5	4	3	2	1	0
RSVD															Y_OFFSET						CURSOR_Y										

## DC\_CURSOR\_Y Bit Descriptions

Bit	Name	Description
31:17	RSVD	<b>Reserved.</b>
16:11	Y_OFFSET	<b>Y Offset.</b> This field represents the Y line offset within the 64x64 cursor pattern at which the displayed portion of the cursor is to begin. Normally, this value is set to zero to display the entire cursor pattern, but for cursors for which the “hot spot” is not at the top edge of the pattern, it may be necessary to display the bottom-most lines of the cursor only as the cursor moves close to the top edge of the display. Note that if this value is non-zero, the DC_CURS_ST_OFFSET (DC Memory Offset 018h) must be set to point to the first cursor line to be displayed.
10:0	CURSOR_Y	<b>Cursor Y.</b> This field represents the Y coordinate of the line at which the upper left corner of the cursor is to be displayed. This value is referenced to the screen origin (0,0), which is the pixel in the upper left corner of the screen.

## 6.6.6.3 DC Line Count/Status (DC\_LINE\_CNT/STATUS)

DC Memory Offset 06Ch

Type RO

Reset Value xxxxxxxxh

This register contains status information for the current display state, including the current scan line for the display (V\_LINE\_CNT). This portion of the register is read only and is used by software to time update the frame buffer to avoid tearing artifacts. This scan line value is driven directly off of the Dot clock, and consequently it is not synchronized with the CPU clock. Software should read this register twice and compare the result to ensure that the value is not transitioning.

Several additional read only display status bits are provided to allow software to properly time the programming of registers and to detect the source of display generated interrupts.

## DC\_LINE\_CNT/STATUS Register Map

31	30	29	28	27	26	25	24	23	22	21	20	19	18	17	16	15	14	13	12	11	10	9	8	7	6	5	4	3	2	1	0
DNA	VNA	VSA	RSVD	FLIP	V_LINE_CNT										VFLIP	SIGC	EVEN_FIELD	RSVD	DOT_LINE_CNT												

## DC\_LINE\_CNT/STATUS Bit Descriptions

Bit	Name	Description
31	DNA	<b>Display Not Active.</b> 0: Display active. 1: Display not active (i.e., blanking or border).
30	VNA	<b>Vertical Not Active.</b> 0: Vertical display active. 1: Vertical display not active (i.e., vertical blanking or border).
29	VSA	<b>Vertical Sync Active.</b> 0: Vertical sync not active. 1: Vertical sync active.
28	RSVD	<b>Reserved.</b>
27	FLIP	<b>Flip.</b> 0: Newly programmed DC_FB_ST_OFFSET (DC Memory Offset 010h[27:0]) has not been latched by display address generation hardware yet. 1: Previously programmed DC_FB_ST_OFFSET (DC Memory Offset 010h[27:0]) has been latched by display address generation hardware.
26:16	V_LINE_CNT	<b>DC Line Count.</b> This value is the current scan line of the DC Engine. The DC Engine, which fetches the frame buffer data, performs compression and de-compression, and overlays cursor data, typically runs several scan lines ahead of the actual display. This allows for buffering and scaling/filtering of graphics data.
15	VFLIP	<b>Video Flip.</b> 0: Newly programmed DC_VID_Y_ST_OFFSET (DC Memory Offset 020h[27:0]) has not been latched by display address generation hardware yet. 1: Previously programmed DC_VID_Y_ST_OFFSET (DC Memory Offset 020h[27:0]) has been latched by display address generation hardware.
14	SIGC	<b>Signature Complete.</b> A 1 in this bit indicates that the CRC signature operation has completed and the resulting signature value may be safely read by software.
13	EVEN_FIELD	<b>Even Field Indicator.</b> When interlacing is enabled, a 1 in this bit indicates that the current field is the even field.
12:11	RSVD	<b>Reserved.</b>
10:0	DOT_LINE_CNT	<b>Dot Line Count.</b> This value is the current scan line of the display. This field is NOT synchronized in hardware, so software should read this value twice to ensure that the result is correct.

### 6.6.7 Palette Access FIFO Diagnostic Registers

The Palette Access registers are used for accessing the internal palette RAM and extensions. In addition to the standard 256 entries for color translation, the palette has extensions for cursor colors and overscan (border) color.

The diagnostics registers enable testability of the display FIFO and compression FIFO.

#### 6.6.7.1 DC Palette Address (DC\_PAL\_ADDRESS)

DC Memory Offset 070h

Type R/W

Reset Value xxxxxxxxh

This register should be written with the address (index) location to be used for the next access to the (DC\_PAL\_DATA register DC Memory Offset 074h).

**DC\_PAL\_ADDRESS Register Map**

31	30	29	28	27	26	25	24	23	22	21	20	19	18	17	16	15	14	13	12	11	10	9	8	7	6	5	4	3	2	1	0
RSVD													PAL_ADDR																		

**DC\_PAL\_ADDRESS Bit Descriptions**

Bit	Name	Description																
31:9	RSVD	<b>Reserved.</b>																
8:0	PAL_ADDR	<p><b>PAL Address.</b> This 9-bit field specifies the address to be used for the next access to the DC_PAL_DATA register (DC Memory Offset 074h). Each access to the data register automatically increments the palette address register. If non-sequential access is made to the palette, the address register must be loaded between each non-sequential data block. The address ranges are as follows:</p> <table border="0"> <thead> <tr> <th>Address</th> <th>Color</th> </tr> </thead> <tbody> <tr> <td>0h - FFh</td> <td>Standard Palette Colors</td> </tr> <tr> <td>100h</td> <td>Cursor Color 0</td> </tr> <tr> <td>101h</td> <td>Cursor Color 1</td> </tr> <tr> <td>102h</td> <td>RSVD</td> </tr> <tr> <td>103h</td> <td>RSVD</td> </tr> <tr> <td>104h</td> <td>Overscan Color</td> </tr> <tr> <td>105h - 1FFh</td> <td>Not Valid</td> </tr> </tbody> </table> <p>Note that in general, 24-bit values are loaded for all color extensions. However, if a 16-bpp mode is active, only the appropriate most significant bits are used (5:5:5 or 5:6:5).</p>	Address	Color	0h - FFh	Standard Palette Colors	100h	Cursor Color 0	101h	Cursor Color 1	102h	RSVD	103h	RSVD	104h	Overscan Color	105h - 1FFh	Not Valid
Address	Color																	
0h - FFh	Standard Palette Colors																	
100h	Cursor Color 0																	
101h	Cursor Color 1																	
102h	RSVD																	
103h	RSVD																	
104h	Overscan Color																	
105h - 1FFh	Not Valid																	

### 6.6.7.2 DC Palette Data (DC\_PAL\_DATA)

DC Memory Offset 074h

Type R/W

Reset Value xxxxxxxxh

This register contains the data for a palette access cycle. When a read or write to the palette RAM occurs, the previous output value is held for one additional Dot clock period. This effect should go unnoticed and will provide for sparkle-free updates. Prior to a read or write to this register, the DC\_PAL\_ADDRESS register (DC Memory Offset 070h) should be loaded with the appropriate address. The address automatically increments after each access to this register, so for sequential access, the address register need only be loaded once.

If the SGRE bit in DC\_GENERAL\_CFG is set (DC Memory Offset 004h[25] = 1), this register reads back the state of the graphics output pixel stream signature.

**DC\_PAL\_DATA Register Map**

31	30	29	28	27	26	25	24	23	22	21	20	19	18	17	16	15	14	13	12	11	10	9	8	7	6	5	4	3	2	1	0
RSVD								PAL_DATA																							

**DC\_PAL\_DATA Bit Descriptions**

Bit	Name	Description
31:24	RSVD	<b>Reserved.</b>
23:0	PAL_DATA	<b>PAL Data.</b> This 24-bit field contains the read or write data for a palette access. If DC_GENERAL_CFG[SGRE] (DC Memory Offset 004h[25]) is set, a read to this register will read back the state of the graphics output pixel stream signature.

### 6.6.7.3 DC Display FIFO Diagnostic (DC\_DFIFO\_DIAG)

DC Memory Offset 078h

Type R/W

Reset Value xxxxxxxxh

This register is provided to enable testability of the display FIFO RAM. Before it is accessed, the DIAG bit in the DC\_GENERAL\_CFG register should be set high (DC Memory Offset 004h[28] = 1) and the DFLE bit should be set low (DC Memory Offset 004h[0] = 0). In addition, the TGEN bit should be set low (DC Memory Offset 008h[0] = 0) and all clock gating should be disabled (MSR 80002004h = 0). Since each FIFO entry is 64 bits, an even number of write operations should be performed. Each pair of write operations causes the FIFO write pointer to increment automatically. After all write operations are performed, a pair of reads of don't care data should be performed to load 64 bits of data into the output latch. Each subsequent read contains the appropriate data that was previously written. Each pair of read operations causes the FIFO read pointer to increment automatically.

This register is also used for writing to the compressed line buffer. Each pair of writes to this register stores a 64-bit data value that is used for the next write to the compressed line buffer. The write pulse to the compressed line buffer is generated by writing dummy data to the DC\_PAL\_DATA register (DC Memory Offset 074h[23:0]) while in DIAG mode.

**DC\_DFIFO\_DIAG Register Map**

31	30	29	28	27	26	25	24	23	22	21	20	19	18	17	16	15	14	13	12	11	10	9	8	7	6	5	4	3	2	1	0
DFIFO_DATA																															

**DC\_DFIFO\_DIAG Bit Descriptions**

Bit	Name	Description
31:0	DFIFO_DATA	<b>Display FIFO Diagnostic Read or Write Data.</b>



**6.6.7.4 DC Compression FIFO Diagnostic (DC\_CFIFO\_DIAG)**

DC Memory Offset 07Ch

Type R/W

Reset Value xxxxxxxh

This register is provided to enable testability of the compressed line buffer (FIFO) RAM. Before it is accessed, the DIAG bit should be set high (DC Memory Offset 004h[28] = 1) and the DFLE bit should be set low (DC Memory Offset 004h[0] = 0). Also, the CFRW bit in DC\_GENERAL\_CFG (DC Memory Offset 004h[29]) should be set appropriately depending on whether a series of reads or writes is to be performed. After each write, the FIFO write pointer automatically increments. After all write operations are performed, the CFRW bit should be set high to enable read addresses to the FIFO and a pair of reads of don't care data should be performed to load 64 bits of data into the output latch. Each subsequent read contains the appropriate data that was previously written. After each pair of reads, the FIFO read pointer automatically increments.

**DC\_CFIFO\_DIAG Register Map**

31	30	29	28	27	26	25	24	23	22	21	20	19	18	17	16	15	14	13	12	11	10	9	8	7	6	5	4	3	2	1	0
CFIFO_DATA																															

**DC\_CFIFO\_DIAG Bit Descriptions**

Bit	Name	Description
31:0	CFIFO_DATA	Compressed Data FIFO Diagnostic Read or Write Data.

## 6.6.8 Video Downscaling

### 6.6.8.1 DC Video Downscaling Delta (DC\_VID\_DS\_DELTA)

DC Memory Offset 080h  
 Type R/W  
 Reset Value 00000000h

This register is provided to allow downscaling of the video overlay image by selective skipping of source lines. A DDA engine is used to identify lines to be skipped according to the following algorithm:

At vertical retrace:

```
PHASE = 0; // clear PHASE initially
skip_flag = 0; // never skip the first line
linenum = 0; // point to first line
For each line of video: send_video_line(linenum); // send line to DF
linenum++ // increment to next line
{skip_flag, PHASE} = PHASE + DELTA; // skip_flag is carry from add
if (skip_flag) linenum = linenum + 1 // skip an additional line if flag was set
else linenum = linenum // otherwise, just skip n lines
```

**DC\_VID\_DS\_DELTA Register Map**

31	30	29	28	27	26	25	24	23	22	21	20	19	18	17	16	15	14	13	12	11	10	9	8	7	6	5	4	3	2	1	0
DELTA														RSVD		VSYNC_SHIFT_EN	RSVD			VSYNC_SHIFT											

**DC\_VID\_DS\_DELTA Bit Descriptions**

Bit	Name	Description
31:18	DELTA	<b>Delta.</b> A 0.14 fixed-point fraction used as the delta value for the DDA engine that calculates which video lines to skip for video downscaling. This register is enabled when the VDSE bit in DC_GENERAL_CFG is set (DC Memory Offset 004h[19] = 1).
17:16	RSVD	<b>Reserved.</b>
15	VSYNC_SHIFT_EN	<b>VSYNC Shift Enable.</b> When this bit is set, the VSYNC output is delayed during even fields in interlaced modes. The amount of delay is defined in VSYNC_SHIFT (bits [11:0]).
14:12	RSVD	<b>Reserved.</b>
11:0	VSYNC_SHIFT	<b>VSYNC Shift.</b> When VSYNC_SHIFT_EN is set (bit 15 = 1), this field determines the number of dot clocks of delay that is inserted on VSYNC during even fields in interlaced modes.

The value to program into DC\_VID\_DS\_DELTA is calculated as follows:

parms: DWORD ORIGINAL\_LINES = full size image line count

DWORD SCALED\_LINES = line count of scaled image equation:

DWORD DC\_VID\_DS\_DELTA = ((ORIGINAL\_LINES << 14) / SCALED\_LINES) << 18;

**Note:** The scaling algorithm is only intended to work for ratios from 1 down to 1/2. The equation above clips the value to the 14 bits of accuracy in the hardware. The equation could be modified to allow for higher bits in the future by changing the 14-bit and 18-bit shift values. The only requirement is that the sum of the shift values be 32.

### 6.6.9 GLIU Control Registers

#### 6.6.9.1 DC GLIU0 Memory Offset (DC\_GLIU0\_MEM\_OFFSET)

DC Memory Offset 084h  
 Type R/W  
 Reset Value 00000000h

This register is used to set a base address for the graphics memory region. The value in this register is added to all outgoing memory addresses. Because the base address must be aligned to a 16 MB region, only bits [31:24] of this register are used.

**DC\_GLIU0\_MEM\_OFFSET Register Map**

31	30	29	28	27	26	25	24	23	22	21	20	19	18	17	16	15	14	13	12	11	10	9	8	7	6	5	4	3	2	1	0
GLIU0_MEM_OFFSET												RSVD										DV_RAM_AD									

**DC\_GLIU0\_MEM\_OFFSET Bit Descriptions**

Bit	Name	Description
31:20	GLIU0_MEM_OFFSET	<b>GLIU0 Memory Offset.</b> Base address (1 MB aligned) for the graphics memory region. This value is added to all outgoing memory addresses.
19:11	RSVD	<b>Reserved.</b> Equal to 0.
10:0	DV_RAM_AD	<b>DV RAM Address.</b> This value is used to allow direct software access to the Dirty/Valid (DV) RAM. The address must be written in this location before reading or writing the DV RAM Access Register (DC Memory Offset 08Ch).

#### 6.6.9.2 DC Dirty/Valid RAM Control (DC\_DV\_CTL)

DC Memory Offset 088h  
 Type R/W  
 Reset Value 00000000h

**DC\_DV\_CTL Register Map**

31	30	29	28	27	26	25	24	23	22	21	20	19	18	17	16	15	14	13	12	11	10	9	8	7	6	5	4	3	2	1	0
DV Address Offset											DV_LINE_SIZE		DV_RANGE		RSVD					DV_MASK	CLEAR_DV_RAM										

**DV\_CTL Bit Descriptions**

Bit	Name	Description
31:12	DV Address Offset	<b>DV Address Offset.</b> When the DV RAM observes memory transactions, the addresses correspond to memory controller device address space. However, the DV RAM is organized based on the internal DC device address space. To account for this, the value indicated by this field is shifted to correspond to address bits [31:12], and then subtracted from memory addresses before determining an offset into the DV RAM. When programming the value in this field, software must calculate the sum of the GLIU0_MEM_OFFSET (DC Memory Offset 084h[31:24] and the appropriate Physical-to-Device descriptor(s) in GLIU0.

**DV\_CTL Bit Descriptions (Continued)**

Bit	Name	Description
11:10	DV_LINE_SIZE	<b>DV Line Size.</b> This field determines how many bytes of frame buffer space correspond to an entry in the DV RAM. The value selected by this field must be greater than or equal to the FB_LINE_SIZE, as programmed in the DC_LINE_SIZE register (DC Memory Offset 030h[9:0]).  00: 1024 (256 QWORDS) 01: 2048 (512 QWORDS) 10: 4096 (1024 QWORDS) 11: 8192 (2048 QWORDS)
9:8	DV_RANGE	<b>DV Range.</b> The value selected by this field is an upper bound of the number of entries used in the DV RAM. By setting this value to a number less than the maximum (2048), there is a potential savings in power, since the DV RAM will not be accessed for lines that may be just above the frame buffer space.  00: 2048 lines 01: 512 lines 10: 1024 lines 11: 1536 lines
7:2	RSVD	<b>Reserved.</b> Set to 0.
1	DV_MASK	<b>DV MASK.</b> While this bit is set, the DV RAM controller does not monitor writes to memory; no DIRTY bits will be set in response to memory activity. When this bit is cleared, the DV RAM behaves normally.
0	CLEAR_DV_RAM	<b>Clear DV RAM.</b> Writing a 1 to this bit causes the contents of the DV RAM to be cleared (i.e., every entry is set to dirty and invalid). This process requires approximately 2050 GLIU0 clocks. This bit may be read to determine if this clear operation is underway (1) or completed (0). Writing a 0 to this bit has no effect.

**6.6.9.3 DC Dirty/Valid RAM Access (DC\_DV\_ACCESS)**

DC Memory Offset 08Ch  
 Type R/W  
 Reset Value 0000000xh

**DC\_DV\_ACCESS Register Map**

31	30	29	28	27	26	25	24	23	22	21	20	19	18	17	16	15	14	13	12	11	10	9	8	7	6	5	4	3	2	1	0
RSVD																DV_VALID	DV_DIRTY														

**DC\_DV\_ACCESS Bit Descriptions**

Bit	Name	Description
31:2	RSVD	<b>Reserved.</b> Set to 0.
1	DV_VALID	<b>DV Valid.</b> Writes to this register place the value of this bit into the “valid” entry of the DV RAM. Reads return the value of the “valid” entry. The DV RAM Address is determined by the value in DV_RAM_AD (DC Memory Offset 084h[10:0]).
0	DV_DIRTY	<b>DV Dirty.</b> Writes to this register will place the value of this bit into the “dirty” entry of the dirty/valid RAM. Reads will return the value of the “dirty” entry. The DV RAM Address is determined by the value in DV_RAM_AD (DC Memory Offset 084h[10:0]).

### 6.6.10 Graphics Scaling Control Registers

#### 6.6.10.1 DC Graphics Filter Scale (DC\_GFX\_SCALE)

DC Memory Offset 090h  
 Type R/W  
 Reset Value 40004000h

**DC\_GFX\_SCALE Register Map**

31	30	29	28	27	26	25	24	23	22	21	20	19	18	17	16	15	14	13	12	11	10	9	8	7	6	5	4	3	2	1	0
V_SCALE																H_SCALE															

**DC\_GFX\_SCALE Bit Descriptions**

Bit	Name	Description
31:16	V_SCALE	<p><b>Vertical Filter Scale.</b> The value in this field, represents the number of vertical lines of source data that are consumed for every line of filtered data produced by the scaler filter. This field is treated as a rational number, with the decimal point between bits 30 and 29. To determine the value to be programmed into this field, use the following formula:</p> $V\_SCALE = (V\_SOURCE / (V\_DEST-1)) \ll 14$ <p>Where V_SOURCE is the height (in scan lines) of the frame buffer and V_DEST is the height (in scan lines) of the destination field.</p> <p>The default value of this field (4000h) represents 1:1 scaling. This value must be programmed when the vertical filter is disabled.</p> <p>The value in this field must not exceed 8000h, which represents a 2:1 downscale ratio. If the width of the source image is more than 1024 pixels, scaling is not supported.</p>
15:0	H_SCALE	<p><b>Horizontal Filter Scale.</b> The value in this field, represents the number of (horizontal) pixels of source data that are consumed for every pixel of data produced by the scaler filter. This field is treated as a rational number, with the decimal point between bits 14 and 13. To determine the value to be programmed into this field, use the following formula:</p> $H\_SCALE = (H\_SOURCE/(H\_DEST-1)) \ll 14$ <p>Where H_SOURCE is the width (in pixels) of the frame buffer and H_DEST is the width (in pixels) of the destination image.</p> <p>The default value of this field (4000h) represents 1:1 scaling. This value must be programmed when the horizontal filter is disabled.</p> <p>The value in this field must never exceed 8000h, which represents a 2:1 horizontal downscale. If the width of the source image is greater than 1024 pixels, scaling is not supported.</p>

### 6.6.10.2 DC IRQ/Filter Control (DC\_IRQ\_FILT\_CTL)

DC Memory Offset 094h

Type R/W

Reset Value 00000000h

#### DC\_IRQ\_FILT\_CTL Register Map

31	30	29	28	27	26	25	24	23	22	21	20	19	18	17	16	15	14	13	12	11	10	9	8	7	6	5	4	3	2	1	0
RSVD	LINEBUF_SEL		INTERLACE_ADDRESSING	RSVD	LINE_COUNT										RSVD	ALPHA_FILT_ENA	RSVD	FILT_ENA	INTL_EN	H_FILT_SEL	RSVD	FILT_ADDR									

#### DC\_IRQ\_FILT\_CTL Bit Descriptions

Bit	Name	Description
31	RSVD	<b>Reserved.</b>
30:29	LINEBUF_SEL	<b>Line Buffer Select.</b> When LINEBUF_REG_EN[0] is set (bit 9 = 1), the coefficient RAM address bits (FILT_ADDR, bits [7:0]) and the Filter Coefficient Data registers (DC Memory Offset 098h and 09Ch) can be used to read and write the line buffer or flicker filter RAMs. This field selects which of the three line buffer RAMs (or two flicker filter RAMs) is to be accessed.
28	INTERLACE_ADDRESSING	<b>Interlace Addressing.</b> This bit indicates whether each field should be vertically decimated when interlacing. If this bit is set, each field of the interlaced frame will include every other line of the original (unscaled) frame buffer image. The flicker filter and scaler filter should both be disabled if this bit is set.
27	RSVD	<b>Reserved.</b>
26:16	LINE_COUNT	<b>Interrupt Line Count.</b> This value determines which scan line will trigger a line count interrupt. When the DC's display engine reaches the line number determined by this value, it will assert an interrupt if IRQ_MASK is cleared (DC Memory Offset 0C8h[0] = 0).
15	RSVD	<b>Reserved.</b>
14	ALPHA_FILT_ENA	<b>Alpha Filter Enable.</b> Settings written to this field will not take effect until the start of the following frame or interlaced field.  Setting this bit to 1 enables the scaler filter for the alpha channel. This filter is provided to support scaling and interlacing of graphics data. If the graphics filter is disabled or this bit is cleared, the alpha channel is not filtered; a nearest-neighbor mechanism is used instead. This can provide cleaner transitions between regions with significantly different alpha values.
13	RSVD	<b>Reserved.</b>
12	FILT_ENA	<b>Graphics Filter Enable.</b> Settings written to this field will not take effect until the start of the following frame or interlaced field.  Setting this bit to 1 enables the graphics scaler filter; This filter is provided to support scaling and interlacing of graphics data.

**DC\_IRQ\_FILTER\_CTL Bit Descriptions (Continued)**

Bit	Name	Description
11	INTL_EN	<b>Interlace Enable.</b> Settings written to this field will not take effect until the start of the following frame or interlaced field.  Setting this bit to 1 configures the output to interlaced mode. In this mode, the vertical timings are based on the even timing registers for every other field. This bit must be set if the flicker filter or address interlacing is enabled.  When using the VGA and interlacing, the scaler must also be used (i.e., bit 12 of this register must be set).
10	H_FILTER_SEL	<b>Horizontal Filter Select.</b> Setting this bit to 1 allows access to the horizontal filter coefficients via this register and the Filter Data Registers (DC Memory Offset 098h and 09Ch). When this bit is cleared, the vertical filter coefficients are accessed instead.
9:8	RSVD	<b>Reserved.</b>
7:0	FILTER_ADDR	<b>Filter Coefficient Address.</b> This indicates which filter location is accessed through reads and writes of the DC Filter Coefficient Data Register 1 (DC Memory Offset 098h).

**6.6.10.3 DC Filter Coefficient Data Register 1 (DC\_FILTER\_COEFF1)**

DC Memory Offset 098h

Type R/W

Reset Value xxxxxxxh

Any read or write of this register causes a read or write of the horizontal or filter coefficient RAM. If this occurs while the display is active, improper filtering of an output pixel can occur, which may cause temporary visual artifacts (speckling). To avoid this, either disable the display or avoid accessing this register unless during vertical blank.

**DC\_FILTER\_COEFF1 Register Map**

31	30	29	28	27	26	25	24	23	22	21	20	19	18	17	16	15	14	13	12	11	10	9	8	7	6	5	4	3	2	1	0
RSVD		TAP3						TAP2						TAP1																	

**DC\_FILTER\_COEFF1 Bit Descriptions**

Bit	Name	Description
31:30	RSVD	<b>Reserved.</b> Set to 0.
29:20	TAP3	<b>Tap 3 Coefficient.</b> This coefficient is used for the third tap in the filter (the lower tap of the vertical filter or the center tap of the horizontal filter). Each of the four components of the pixel color (Red, Green, Blue, and Alpha, if available) is expanded to 8 bits and then multiplied by this value before being summed with the weighted results of the other filter taps.
19:10	TAP2	<b>Tap 2 Coefficient.</b> This coefficient is used for the second tap in the filter (the center tap of the vertical filter or the second tap from the left in the horizontal filter).
9:0	TAP1	<b>Tap 1 Coefficient.</b> This coefficient is used for the first tap in the filter (the upper tap of the vertical filter or the leftmost tap of the horizontal filter).

#### 6.6.10.4 DC Filter Coefficient Data Register 2 (DC\_FILT\_COEFF2)

DC Memory Offset 09Ch  
 Type R/W  
 Reset Value xxxxxxxxh

Any read or write of this register causes a read or write of the horizontal or filter coefficient RAM. If this occurs while the display is active, improper filtering of an output pixel can occur, which may cause temporary visual artifacts (speckling). To avoid this, either disable the display or avoid accessing this register unless during vertical blank.

#### DC\_FILT\_COEFF2 Register Map

31	30	29	28	27	26	25	24	23	22	21	20	19	18	17	16	15	14	13	12	11	10	9	8	7	6	5	4	3	2	1	0
RSVD												TAP5										TAP4									

#### DC\_FILT\_COEFF2 Bit Descriptions

Bit	Name	Description
31:20	RSVD	<b>Reserved.</b> Set to 0. This field is used only when reading or writing the Line Buffer Register.
19:10	TAP5	<b>Tap 5 Coefficient.</b> This coefficient is used for the fifth tap (rightmost) in the horizontal filter.
9:0	TAP4	<b>Tap 4 Coefficient.</b> This coefficient is used for the fourth tap (second from the right) in the horizontal filter.

### 6.6.11 VBI Control Registers

#### 6.6.11.1 DC VBI Even Control (DC\_VBI\_EVEN\_CTL)

DC Memory Offset 0A0h  
 Type R/W  
 Reset Value xxxxxxxxh

Settings written to this register do not take effect until the start of the following frame or interlaced field.

#### DC\_VBI\_EVEN\_CTL Register Map

31	30	29	28	27	26	25	24	23	22	21	20	19	18	17	16	15	14	13	12	11	10	9	8	7	6	5	4	3	2	1	0
VBI_SIG_EN	VBI_16	VBI_UP	VBI_ENA	VBI_EVEN_OFFSET																							0				

#### DC\_VBI\_EVEN\_CTL Bit Descriptions

Bit	Name	Description
31	VBI_SIG_EN	<b>VBI Signature Enable.</b> This bit allows the CRC engine at the output of the DC to be used to check VBI data instead of graphics data. When this bit is set, the CRC is generated based only on VBI data; when cleared, only graphics data is used for the CRC calculation.
30	VBI_16	<b>VBI 16-bit Enable.</b> When set, VBI data is sent 16 bits per Dot clock. When clear, VBI data is sent 8 bits per Dot clock.
29	VBI_UP	<b>VBI Upscale.</b> When set, the VBI data is upscaled by 2. This is accomplished by repeating data twice.



**DC\_VBI\_EVEN\_CTL Bit Descriptions (Continued)**

Bit	Name	Description
28	VBI_ENA	<b>VBI Enable.</b> Setting this bit to 1 enables VBI (Vertical Blank Interrupt) data. This is a data stream that is placed in the off-screen region at the start of each field. This data is passed through the graphics output path, but is not filtered or modified in any way.
27:0	VBI_EVEN_OFFSET	<b>VBI Even Address Offset.</b> Indicates the starting offset for VBI data for even fields. This address must be QWORD aligned; the low three bits are always 0. If interlacing is disabled, this offset is used for VBI data.

**6.6.11.2 DC VBI Odd Control (DC\_VBI\_ODD\_CTL)**

DC Memory Offset 0A4h

Type R/W

Reset Value xxxxxxxxh

Settings written to this register do not take effect until the start of the following frame or interlaced field.

**DC\_VBI\_ODD\_CTL Register Map**

31	30	29	28	27	26	25	24	23	22	21	20	19	18	17	16	15	14	13	12	11	10	9	8	7	6	5	4	3	2	1	0
RSVD			VBI_ODD_OFFSET														0														

**DC\_VBI\_ODD\_CTL Bit Descriptions**

Bit	Name	Description
31:28	RSVD	<b>Reserved.</b> Set to 0.
27:0	VBI_ODD_OFFSET	<b>VBI Odd Address Offset.</b> Indicates the starting offset for VBI data for odd fields. This address must be QWORD aligned; the low three bits are always 0. If interlacing is disabled, the even offset is used for VBI data.

**6.6.11.3 DC VBI Horizontal Control (DC\_VBI\_HOR)**

DC Memory Offset 0A8h

Type R/W

Reset Value xxxxxxxxh

Settings written to this register do not take effect until the start of the following frame or interlaced field.

**DC\_VBI\_HOR Register Map**

31	30	29	28	27	26	25	24	23	22	21	20	19	18	17	16	15	14	13	12	11	10	9	8	7	6	5	4	3	2	1	0
RSVD			VBI_H_END										RSVD			VBI_H_START															

**DC\_VBI\_HOR Bit Descriptions**

Bit	Name	Description
31:28	RSVD	<b>Reserved.</b> Set to 0.
27:16	VBI_H_END	<b>VBI Horizontal End.</b> Specifies the horizontal end position for VBI data minus 1 pixel.
15:12	RSVD	<b>Reserved.</b> Set to 0.
11:0	VBI_H_START	<b>VBI Horizontal Start.</b> Specifies the horizontal start position for VBI data minus 1 pixel.

**6.6.11.4 DC VBI Odd Line Enable (DC\_VBI\_LN\_ODD)**

DC Memory Offset 0ACh

Type R/W

Reset Value xxxxxxxxh

Settings written to this register do not take effect until the start of the following frame or interlaced field.

**DC\_VBI\_LN\_ODD Register Map**

31	30	29	28	27	26	25	24	23	22	21	20	19	18	17	16	15	14	13	12	11	10	9	8	7	6	5	4	3	2	1	0
LN_OFFSET_ODD							LN_EN_ODD															RSVD									

**DC\_VBI\_LN\_ODD Bit Descriptions**

Bit	Name	Description
31:25	LN_OFFSET_ODD	<b>Odd Line Offset.</b> Specifies the offset (in lines) of the start of VBI data from the initial edge of VSYNC. This field is not used if interlacing is disabled. This field must be set to a value of 126 or less.
24:2	LN_EN_ODD	<b>Odd Line Enable.</b> Each of the bits in this field corresponds to a line (24-2) of VBI data. Setting a bit in this field to 1 enables the corresponding line of VBI data in the odd field. This field is not used if interlacing is disabled.
1:0	RSVD	<b>Reserved.</b> Set to 0.

**6.6.11.5 DC VBI Even Line Enable (DC\_VBI\_LN\_EVEN)**

DC Memory Offset 0B0h

Type R/W

Reset Value xxxxxxxxh

Settings written to this register do not take effect until the start of the following frame or interlaced field.

**DC\_VBI\_LN\_EVEN Register Map**

31	30	29	28	27	26	25	24	23	22	21	20	19	18	17	16	15	14	13	12	11	10	9	8	7	6	5	4	3	2	1	0
LN_OFFSET_EVEN							LN_EN_EVEN															RSVD									

**DC\_VBI\_LN\_EVEN Bit Descriptions**

Bit	Name	Description
31:25	LN_OFFSET_EVEN	<b>Even Line Offset.</b> Specifies the offset (in lines) of the start of VBI data from the initial edge of VSYNC. This field is used for all frames if interlacing is disabled. This field must be set to a value of 126 or less.
24:2	LN_EN_EVEN	<b>Even Line Enable.</b> Each of the bits in this field corresponds to a line (24-2) of VBI data. Setting a bit in this field to 1 enables the corresponding line of VBI data in the even field. This field is used for all frames if interlacing is disabled.
1:0	RSVD	<b>Reserved.</b> Set to 0.

### 6.6.11.6 DC VBI Pitch and Size (DC\_VBI\_PITCH)

DC Memory Offset 0B4h

Type R/W

Reset Value xxxxxxxxh

#### DC\_VBI\_PITCH Register Map

31	30	29	28	27	26	25	24	23	22	21	20	19	18	17	16	15	14	13	12	11	10	9	8	7	6	5	4	3	2	1	0
RSVD						VBI_Size										VBI_Pitch															

#### DC\_VBI\_PITCH Bit Descriptions

Bit	Name	Description
31:26	RSVD	<b>Reserved.</b> Set to 0.
25:16	VBI_SIZE	<b>VBI Data Size.</b> Indicates how many QWORDS of data to fetch from memory for each line of VBI
15:0	VBI_PITCH	<b>VBI Data Pitch.</b> Indicates how many QWORDS of memory space to increment when moving from the start of one active VBI line to the start of the next.

### 6.6.12 Color Key Control Registers

#### 6.6.12.1 DC Color Key (DC\_CLR\_KEY)

DC Memory Offset 0B8h

Type R/W

Reset Value 00000000h

#### DC\_CLR\_KEY Register Map

31	30	29	28	27	26	25	24	23	22	21	20	19	18	17	16	15	14	13	12	11	10	9	8	7	6	5	4	3	2	1	0
RSVD							CLR_KEY_EN	CLR_KEY																							

#### DC\_CLR\_KEY Bit Descriptions

Bit	Name	Description
31:25	RSVD	<b>Reserved.</b> Set to 0.
24	CLR_KEY_EN	<b>Color Key Enable.</b> This bit enables color key detection in the DC. When this bit is set, the DC adjusts the alpha value of pixels whose 24-bit RGB values match the value in CLR_KEY (bits [23:0]). A mask is also provided in CLR_KEY_MASK (DC Memory Offset 0BCh[23:0]) to indicate which bits can be ignored when performing this match. Color key detection is performed after the data has been decompressed and the cursor has been overlaid, but before scaling and filtering take place.
23:0	CLR_KEY	<b>Color Key.</b> This field represents the RGB value that will be compared to DC pixels when performing color key detection.

**6.6.12.2 DC Color Key Mask (DC\_CLR\_KEY\_MASK)**

DC Memory Offset 0BCh  
 Type R/W  
 Reset Value 00xxxxxxh

**DC\_CLR\_KEY\_MASK Register Map**

31	30	29	28	27	26	25	24	23	22	21	20	19	18	17	16	15	14	13	12	11	10	9	8	7	6	5	4	3	2	1	0
RSVD								CLR_KEY_MASK																							

**DC\_CLR\_KEY\_MASK Bit Descriptions**

Bit	Name	Description
31:24	RSVD	<b>Reserved.</b> Set to 0.
23:0	CLR_KEY_MASK	<b>Color Key Mask.</b> This field is ANDed with both the pixel and the color key value (in DC_CLR_KEY, DC Memory Offset 0B8h[23:0]) before comparing the values. This allows the value of some bits to be ignored when performing the match.

**6.6.12.3 DC Color Key Horizontal Position (DC\_CLR\_KEY\_X)**

DC Memory Offset 0C0h  
 Type R/W  
 Reset Value 00000000h

Settings written to this register do not take effect until the start of the following frame or interlaced field.

**DC\_CLR\_KEY\_X Register Map**

31	30	29	28	27	26	25	24	23	22	21	20	19	18	17	16	15	14	13	12	11	10	9	8	7	6	5	4	3	2	1	0
RSVD				CLR_KEY_X_END								RSVD				CLR_KEY_X_START															

**DC\_CLR\_KEY\_X Bit Descriptions**

Bit	Name	Description
31:27	RSVD	<b>Reserved.</b> Set to 0.
26:16	CLR_KEY_X_END	<b>Color Key Horizontal End.</b> This field indicates the horizontal end position of the color key region minus 1. This represents the first pixel past the end of the color key region. This field is 0-based; the upper left pixel of the screen is represented by (0,0).
15:11	RSVD	<b>Reserved.</b> Set to 0.
10:0	CLR_KEY_X_START	<b>Color Key Horizontal Start.</b> This field represents the horizontal start position of the color key region minus 1. This represents the first pixel within the color key region.

**6.6.12.4 DC Color Key Vertical Position (DC\_CLR\_KEY\_Y)**

DC Memory Offset 0C4h  
 Type R/W  
 Reset Value 00000000h

Settings written to this register do not take effect until the start of the following frame or interlaced field.

**DC\_CLR\_KEY\_Y Register Map**

31	30	29	28	27	26	25	24	23	22	21	20	19	18	17	16	15	14	13	12	11	10	9	8	7	6	5	4	3	2	1	0
RSVD				CLR_KEY_Y_END								RSVD				CLR_KEY_Y_START															

**DC\_CLR\_KEY\_Y Bit Descriptions**

Bit	Name	Description
31:27	RSVD	<b>Reserved.</b> Set to 0.
26:16	CLR_KEY_Y_END	<b>Color Key Vertical End.</b> This field represents the vertical end position of the color key region minus 1. This represents the first line past the end of the color key region.
15:11	RSVD	<b>Reserved.</b> Set to 0.
10:0	CLR_KEY_Y_START	<b>Color Key Vertical Start.</b> This field represents the vertical start position of the color key region minus 1. This represents the first line within the color key region.

**6.6.12.5 DC Interrupt (DC\_IRQ)**

DC Memory Offset 0C8h  
 Type R/W  
 Reset Value 00000003h

**DC\_IRQ Register Map**

31	30	29	28	27	26	25	24	23	22	21	20	19	18	17	16	15	14	13	12	11	10	9	8	7	6	5	4	3	2	1	0
RSVD														VIP_VSYNC_LOSS_IRQ	IRQ	RSVD														VIP_VSYNC_LOSS_IRQ_MASK	IRQ_MASK

**DC\_IRQ Bit Descriptions**

Bit	Name	Description
31:18	RSVD	<b>Reserved.</b> Set to 0.
17	VIP_VSYNC_LOSS_IRQ	<b>VIP VSYNC Loss IRQ.</b> If set to 1, this field indicates that while GenLock was enabled, GenLock timeout was enabled, and the DC reached the end of a frame and detected VIP_VIDEO_OK (DC Memory Offset D4h[23]) inactive. As a result of this condition, the DC began display of a field/frame based on its own timings.
16	IRQ	<b>IRQ Status.</b> If set to 1, this field indicates that the vertical counter has reached the value set in the IRQ/Filter Control Register. The state of the IRQ_MASK, bit 0, will not prevent this bit from being set. To clear the interrupt, write a 1 to this bit.
15:2	RSVD	<b>Reserved.</b> Set to 0.
1	VIP_VSYNC_LOSS_IRQ_MASK	<b>VIP VSYNC Loss IRQ Mask.</b> Masks generation of an interrupt in the event that the DC reaches the end of a frame with GenLock enabled and GenLock timeout enabled and determines that the VIP_VIDEO_OK (DC Memory Offset D4h[23]) input is inactive.
0	IRQ_MASK	<b>IRQ Mask.</b> Setting this bit to 1 prevents the Display Controller from generating an interrupt signal when the vertical counter reaches the value programmed in DC_IRQ_FILT_CTL (DC Memory Offset 094h). Clearing this bit disables interrupt generation, but will NOT prevent IRQ, bit 16, from being set.

### 6.6.13 Interrupt and GenLock Registers

#### 6.6.13.1 DC GenLock Control (DC\_GENLK\_CTL)

DC Memory Offset 0D4h

Type R/W

Reset Value xxxxxxxxh

Settings written to this register do not take effect until the start of the frame or interlaced field after the timing register update bit (DC Memory Offset 008h[6]) is set.

**DC\_GENLK\_CTL Register Map**

31	30	29	28	27	26	25	24	23	22	21	20	19	18	17	16	15	14	13	12	11	10	9	8	7	6	5	4	3	2	1	0
FLICK_SEL				RSVD		ALPHA_FLICK_EN	FLICK_EN	VIP_VIDEO_OK	GENLOCK_ACTIVE	SKEW_WAIT	VIP_VSYNC_WAIT	GENLK_TO_EN	GENLK_EN	GENLK_SKW																	

**DC\_GENLK\_CTL Bit Descriptions**

Bit	Name	Description
31:28	FLICK_SEL	<b>Flicker Filter Select.</b> When the flicker filter is enabled (FLICK_EN, bit 24 = 1), this field selects the weighting of the three taps in this vertical filter: 0000: 0, 1, 0 (top, middle, bottom) 0001: 1/16, 7/8, 1/16 0010: 1/8, 3/4, 1/8 0100: 1/4, 1/2, 1/4 0101: 5/16, 3/8, 5/16 All other combinations in this field are reserved.
27:26	RSVD	<b>Reserved.</b> Set to 0.
25	ALPHA_FLICK_EN	<b>Alpha Flicker Filter Enable.</b> If set, this bit enables flicker filtering of the alpha value when the flicker filter is enabled (FLICK_EN, bit 24 = 1). If the flicker filter is enabled and this bit is cleared, the alpha value of the center pixel is passed through the flicker filter unchanged.
24	FLICK_EN	<b>Flicker Filter Enable.</b> Enables the 3-tap vertical flicker filter (primarily used for interlaced modes). When set, the graphics output is filtered vertically using the coefficients as indicated in bits [22:21]. When clear, no flicker filtering is performed.
23	VIP_VIDEO_OK (RO)	<b>VIP Video OK (Read Only).</b> This bit indicates the state of the internal VIP VIDEO_OK input. This signal is driven by the VIP to indicate that the VIP is detecting a valid input stream.
22	GENLOCK_ACTIVE (RO)	<b>GenLock Active (Read Only).</b> This bit indicates that the current (or most recent) field/frame was initiated as the result of an active VIP VSYNC. The state of this bit will change coincident with the activation of the VSYNC output. If the VSYNC output occurs as the result of a timeout condition, this bit will be cleared. If GenLock is not enabled (GENLK_EN, bit 18 = 0), this bit will be cleared.
21	SKEW_WAIT (RO)	<b>Skew Wait (Read Only).</b> This status bit indicates that the DC has received a VSYNC from the VIP and that the skew counter is running. This bit is set when the VIP_VSYNC input is set and cleared when the skew counter expires.

**DC\_GENLK\_CTL Bit Descriptions (Continued)**

Bit	Name	Description
20	VIP_VSYNC_WAIT (RO)	<b>VIP VSYNC Wait (Read Only).</b> If set to 1 this status bit indicates that the DC has completed a field or frame and is waiting for the VIP's VSYNC to go active before beginning another frame. Typically, this will occur only if the VIP_VIDEO_OK (bit 23) input is active or the GENLOCK_TO_EN (bit 19) is inactive.
19	GENLK_TO_EN	<b>GenLock Time Out Enable.</b> Setting this bit allows the DC to revert to its own internal timer if a loss of sync is detected by the VIP. This allows for seamless operation of the DC in GenLock mode when the VIP input becomes unstable. Clearing this bit forces the DC to wait for a VSYNC signal from the VIP even if the VIP indicates a loss of sync.
18	GENLK_EN	<b>GenLock Enable.</b> When set to 1, the DC resets to the start of the frame/field upon receipt of a rising edge on the VIP_VSYNC signal.
17:0	GENLK_SKW	<b>GenLock Skew.</b> This value indicates how many Dot clocks to delay the internal recognition of the VIP VSYNC by the DC when GenLock is enabled. If GenLock timeout is also enabled (GENLK_TO_EN, bit 19 = 1), internal recognition of VSYNC occurs immediately upon timeout (without allowing this skew time to elapse after the timeout is detected.) This allows seamless transition from a VIP-supplied VSYNC to an internally-determined VSYNC, while still allowing for a delay in timeout detection.

**6.6.14 Even Field Video Address Registers**

**6.6.14.1 DC Even Field Video Y Start Address Offset (DC\_VID\_EVEN\_Y\_ST\_OFFSET)**

DC Memory Offset 0D8h

Type R/W

Reset Value xxxxxxxxh

Settings written to this register do not take effect until the start of the next even interlaced field.

**DC\_VID\_EVEN\_Y\_ST\_OFFSET Register Map**

31	30	29	28	27	26	25	24	23	22	21	20	19	18	17	16	15	14	13	12	11	10	9	8	7	6	5	4	3	2	1	0
RSVD				OFFSET																											

**DC\_VID\_EVEN\_Y\_ST\_OFFSET Bit Descriptions**

Bit	Name	Description
31:28	RSVD	<b>Reserved.</b> Set to 0.
27:0	OFFSET	<b>Video Y Even Buffer Start Offset.</b> This value represents the starting location for Video Y Buffer for even fields when interlacing is enabled. This field is not used when interlacing is disabled (DC Memory Offset 094h[11] = 0).  This value represents the starting location for Video Y Buffer for even fields when interlacing is enabled (DC Memory Offset 094h[11] = 1). The lower five bits should always be programmed as zero so that the start offset is aligned to a 32-byte boundary. If YUV 4:2:2 mode is selected (DC Memory Offset 004h[20] = 0), the Video Y Buffer is used as a singular buffer holding interleaved Y, U and V data. If YUV 4:2:0 is selected (DC Memory Offset 004h[20] = 1), the Video Y Buffer is used to hold only Y data while U and V data are stored in separate buffers.

**6.6.14.2 DC Even Field Video U Start Address Offset (DC\_VID\_EVEN\_U\_ST\_OFFSET)**

DC Memory Offset 0DCh  
 Type R/W  
 Reset Value xxxxxxxxh

Settings written to this register do not take effect until the start of the next even interlaced field.

**DC\_VID\_EVEN\_U\_ST\_OFFSET Register Map**

31	30	29	28	27	26	25	24	23	22	21	20	19	18	17	16	15	14	13	12	11	10	9	8	7	6	5	4	3	2	1	0
RSVD				OFFSET																											

**DC\_VID\_EVEN\_U\_ST\_OFFSET Bit Descriptions**

Bit	Name	Description
31:28	RSVD	<b>Reserved.</b> Set to 0.
27:0	OFFSET	<b>Video U Even Buffer Start Offset.</b> This value represents the starting location for Video U Buffer for even fields when interlacing is enabled (DC Memory Offset 094h[11] = 1) and YUV 4:2:0 mode is selected (DC Memory Offset 004h[20] = 1). The lower five bits should always be programmed as zero so that the start offset is aligned to a 32-byte boundary.

**6.6.14.3 DC Even Field Video V Start Address Offset (DC\_VID\_EVEN\_V\_ST\_OFFSET)**

DC Memory Offset 0E0h  
 Type R/W  
 Reset Value xxxxxxxxh

Settings written to this register do not take effect until the start of the next even interlaced field.

**DC\_VID\_EVEN\_V\_ST\_OFFSET Register Map**

31	30	29	28	27	26	25	24	23	22	21	20	19	18	17	16	15	14	13	12	11	10	9	8	7	6	5	4	3	2	1	0
RSVD				OFFSET																											

**DC\_VID\_EVEN\_V\_ST\_OFFSET Bit Descriptions**

Bit	Name	Description
31:28	RSVD	<b>Reserved.</b> Set to 0.
27:0	OFFSET	<b>Video V Even Buffer Start Offset.</b> This value represents the starting location for Video V Buffer for even fields when interlacing is enabled (DC Memory Offset 094h[11] = 1) and YUV 4:2:0 is selected (DC Memory Offset 004h[20] = 1). The lower five bits should always be programmed as zero so that the start offset is aligned to a 32-byte boundary.



## 6.6.15 Even Field Vertical Timing Registers

### 6.6.15.1 DC Vertical and Total Timing for Even Fields (DC\_V\_ACTIVE\_EVEN\_TIMING)

DC Memory Offset 0E4h

Type R/W

Reset Value xxxxxxxxh

This register contains vertical active and total timing information. These parameters pertain ONLY to even fields in interlaced display modes (The DC\_V\_ACTIVE\_TIMING register (DC Memory Offset 050h) will take effect for odd fields in interlaced display modes.) Settings written to this register will not take effect until the start of the frame or interlaced field after the timing register update bit is set (DC Memory Offset 008h[6] = 1).

#### DC\_V\_ACTIVE\_EVEN\_TIMING Register Map

31	30	29	28	27	26	25	24	23	22	21	20	19	18	17	16	15	14	13	12	11	10	9	8	7	6	5	4	3	2	1	0
RSVD				V_TOTAL								RSVD				V_ACTIVE															

#### DC\_V\_ACTIVE\_EVEN\_TIMING Bit Descriptions

Bit	Name	Description
31:27	RSVD	<b>Reserved.</b> These bits should be programmed to zero.
26:16	V_TOTAL	<b>Vertical Total.</b> This field represents the total number of lines for a given frame scan minus 1. Note that the value is necessarily greater than the V_ACTIVE field (bits 10:0) because it includes border lines and blanked lines.
15:11	RSVD	<b>Reserved.</b> These bits should be programmed to zero.
10:0	V_ACTIVE	<p><b>Vertical Active.</b> This field represents the total number of lines for the displayed portion of a frame scan minus 1. Note that for flat panels, if this value is less than the panel active vertical resolution (V_PANEL), the parameters V_BLANK_START, V_BLANK_END, V_SYNC_START, and V_SYNC_END should be reduced by the following value (V_ADJUST) to achieve vertical centering:</p> $V\_ADJUST = (V\_PANEL - V\_ACTIVE) / 2$ <p>If graphics scaling is enabled (and interleaved display is enabled), this value represents the height of the final (scaled) field to be displayed. The height of the frame buffer image may be different in this case; FB_ACTIVE (DC Memory Offset 5Ch) is used to program the horizontal and vertical active values in the frame buffer when graphics scaling is enabled.</p>

### 6.6.15.2 DC CRT Vertical Blank Timing for Even Fields (DC\_V\_BLANK\_EVEN\_TIMING)

DC Memory Offset 0E8h

Type R/W

Reset Value xxxxxxxxh

This register contains vertical blank timing information. All values are specified in lines. This register is used ONLY for even fields in interlaced display modes. Settings written to this register do not take effect until the start of the frame or interlaced field after the timing register update bit is set (DC Memory Offset 008h[6] = 1).

#### DC\_V\_BLANK\_EVEN\_TIMING Register Map

31	30	29	28	27	26	25	24	23	22	21	20	19	18	17	16	15	14	13	12	11	10	9	8	7	6	5	4	3	2	1	0
RSVD				V_BLANK_END								RSVD				V_BLANK_START															

#### DC\_V\_BLANK\_EVEN\_TIMING Bit Descriptions

Bit	Name	Description
31:27	RSVD	<b>Reserved.</b> These bits should be programmed to zero.
26:16	V_BLANK_END	<b>Vertical Blank End.</b> This field represents the line at which the vertical blanking signal becomes inactive minus 1. If the display is interlaced, no border is supported, so this value should be identical to V_TOTAL (DC Memory Offset 0E4h[26:16]).
15:11	RSVD	<b>Reserved.</b> These bits should be programmed to zero.
10:0	V_BLANK_START	<b>Vertical Blank Start.</b> This field represents the line at which the vertical blanking signal becomes active minus 1. If the display is interlaced, this value should be programmed to V_ACTIVE (DC Memory Offset 0E4h[10:0]) plus 1.

### 6.6.15.3 DC CRT Vertical Sync Timing for Even Fields (DC\_V\_SYNC\_EVEN\_TIMING)

DC Memory Offset 0ECh

Type R/W

Reset Value xxxxxxxxh

This register contains CRT vertical sync timing information. All values are specified in lines. This register is used ONLY for even fields in interlaced modes. Settings written to this register do not take effect until the start of the frame or interlaced field after the timing register update bit is set (DC Memory Offset 008h[6] = 1).

#### DC\_V\_SYNC\_EVEN\_TIMING Register Map

31	30	29	28	27	26	25	24	23	22	21	20	19	18	17	16	15	14	13	12	11	10	9	8	7	6	5	4	3	2	1	0
RSVD				V_SYNC_END								RSVD				V_SYNC_START															

#### DC\_V\_SYNC\_EVEN\_TIMING Bit Descriptions

Bit	Name	Description
31:27	RSVD	<b>Reserved.</b> These bits should be programmed to zero.
26:16	V_SYNC_END	<b>Vertical Sync End.</b> This field represents the line at which the CRT vertical sync signal becomes inactive minus 1.
15:11	RSVD	<b>Reserved.</b> These bits should be programmed to zero.
10:0	V_SYNC_START	<b>Vertical Sync Start.</b> This field represents the line at which the CRT vertical sync signal becomes active minus 1. For interlaced display, note that the vertical counter is incremented twice during each line and since there are an odd number of lines, the vertical sync pulse will trigger in the middle of a line for one field and at the end of a line for the subsequent field.

### 6.6.16 VGA Block Configuration Registers

#### 6.6.16.1 VGA Configuration (VGA\_CONFIG)

DC Memory Offset 100h  
 Type R/W  
 Reset Value 00000000h

This register controls palette write operations.

**VGA\_CONFIG Register Map**

31	30	29	28	27	26	25	24	23	22	21	20	19	18	17	16	15	14	13	12	11	10	9	8	7	6	5	4	3	2	1	0
RSVD																											WPPAL				

**VGA\_CONFIG Bit Descriptions**

Bit	Name	Description
31:1	RSVD	<b>Reserved.</b> Set to 0.
0	WPPAL	<b>Write Protect Palette.</b> If set to 1, VGA palette write operations are NOT written to the palette RAMs. Palette writes behave normally, except that the data is discarded.

#### 6.6.16.2 VGA Status (VGA\_STATUS)

DC Memory Offset 104h  
 Type RO  
 Reset Value 00000000h

This register provides status information for the individual SMI events enabled in the VGA\_CONFIG register (DC Memory Offset 100h), as well as certain other status bits. Reading this register clears all active events.

**VGA\_STATUS Register Map**

31	30	29	28	27	26	25	24	23	22	21	20	19	18	17	16	15	14	13	12	11	10	9	8	7	6	5	4	3	2	1	0
RSVD		BLINK_CNT				RSVD		V_CNT						RSVD					VSYNC	DISPEN	CRTCIO_SMI	VBLANK_SMI	ISR0_SMI	MISC_SMI							

**VGA\_STATUS Bit Descriptions**

Bit	Name	Description
31:30	RSVD	<b>Reserved.</b>
29:24	BLINK_CNT	<b>Blink Counter Value.</b> Unsynchronized, used as a simulation aid.
23:22	RSVD	<b>Reserved.</b>
21:12	V_CNT	<b>Vertical Counter Value.</b> Unsynchronized, used as a simulation aid.
11:6	RSVD	<b>Reserved.</b>
5	VSYNC	<b>VSYNC.</b> 1 if VSYNC is active (copy of bit 3 of ISR1).
4	DISPEN	<b>Display Enable.</b> 0 if both horizontal and vertical display enable are active (copy of bit 0 of ISR1).
3	CRTCIO_SMI	<b>CRTC Register SMI.</b> If = 1, an SMI was generated due to an I/O read or write to a non-implemented CRTC register.

**VGA\_STATUS Bit Descriptions (Continued)**

Bit	Name	Description
2	VBLANK_SMI	<b>VBLANK SMI.</b> If = 1, an SMI was generated due to leading edge vertical blank.
1	ISR0_SMI	<b>Input Status Register 0 SMI.</b> If = 1, an SMI was generated from an I/O IN to Input Status Register 0.
0	MISC_SMI	<b>Miscellaneous Output Register SMI.</b> If = 1, an SMI was generated from an I/O OUT to the Miscellaneous Output Register.

**6.6.17 VGA Block Standard Registers****6.6.17.1 VGA Miscellaneous Output**

Read Address 3CCh  
 Write Address 3C2h  
 Type R/W  
 Reset Value 02h

**VGA Miscellaneous Output Register Bit Descriptions**

Bit	Name	Description
7	VSYNC_POL	<b>Vertical Sync Polarity.</b> Selects a positive-going VSYNC pulse (bit = 0) or a negative-going VSYNC pulse (bit = 1).
6	HSYNC_POL	<b>Horizontal Sync Polarity.</b> Selects a positive-going HSYNC pulse (bit = 0) or a negative-going HSYNC pulse (bit = 1).
5	PAGE	<b>Page Bit.</b> This bit is used to replace memory address bit A0 as the LSB when bit 1 of the Miscellaneous register (Index 06h[1]) in the VGA Graphics Controller is set to 1.
4	RSVD	<b>Reserved.</b>
3:2	CLK_SEL	<b>Clock Select.</b> Selects the VGA pixel clock source. Writes to this register will directly affect the frequency generated by the Dot clock PLLs. The value of this register is sampled when it is written; The Dot clock frequency can be overridden by subsequent writes to the Dot clock PLL controls. If the VGA is disabled or in fixed timing mode, the Dot clock frequency is NOT affected by writes to this register.  00: Selects clock for 640/320 pixels per line (25.175 MHz Dot clock). 01: Selects clock for 720/360 pixels per line (28.325 MHz Dot clock). 10: Reserved. 11: Reserved.
1	RAM_EN	<b>RAM Enable.</b> Enables the video frame buffer address decode when set to 1.
0	ID_ADDR_SEL	<b>I/O Address Select.</b> Determines the I/O address of the CRTIC Index and Data registers (Index 3?4h and 3?5h), Feature Control register (Index 3?Ah), and Input Status Register 1 (Index 3?Ah) as follows: ? = B when bit set to 0 (MDA I/O address emulation), ? = D when bit set to 1 (CGA address emulation).

**6.6.17.2 VGA Input Status Register 0**

Read Address 3C2h  
 Write Address --  
 Type R/W  
 Reset Value 00h

**VGA Input Status Register 0 Bit Descriptions**

Bit	Name	Description
7	RSVD	<b>Not Implemented.</b> (CRTIC Interrupt Pending)
6:5	RSVD	<b>Reserved.</b>
4	RSVD	<b>Not Implemented.</b> (Display Sense)
3:0	RSVD	<b>Reserved.</b>

**6.6.17.3 VGA Input Status Register 1**

Read Address 3BAh or 3DAh  
 Write Address --  
 Type R/W  
 Reset Value 01h

**VGA Input Status Register 1 Bit Descriptions**

Bit	Name	Description
7:4	RSVD	<b>Reserved.</b>
3	VSYNC	<b>Vertical SYNC.</b> When a 1, indicates that the VSYNC signal is active.
2:1	RSVD	<b>Reserved.</b>
0	DISP_EN	<b>Display Enable.</b> Reads as a 0 when both horizontal and vertical display enable are active. Reads as a 1 when either display enable signal is inactive.

**6.6.17.4 VGA Feature Control**

Read Address 3CAh  
 Write Address 3BAh or 3DAh  
 Type R/W  
 Reset Value xxh

**VGA Feature Control Register Bit Descriptions**

Bit	Name	Description
7:0	RSVD	<b>Reserved.</b>

### 6.6.18 VGA Sequencer Registers

The Sequencer registers are accessed by writing an index value to the Sequencer Index register (3C4h) and reading or writing the register using the Sequencer Data register (3C5h).

**Table 6-51. VGA Sequencer Registers Summary**

Index	Type	Register	Reset Value	Reference
--	R/W	VGA Sequencer Index	0xh	Page 358
--	R/W	VGA Sequencer Data	xxh	Page 358
00h	R/W	VGA Reset	00h	Page 358
01h	R/W	VGA Clocking Mode	02h	Page 359
02h	R/W	VGA Map Mask	00h	Page 359
03h	R/W	VGA Character Map Select	xxh	Page 360
04h	R/W	VGA Memory Mode	02h	Page 360

#### 6.6.18.1 VGA Sequencer Index

Index Address 3C4h  
 Type R/W  
 Reset Value 0xh

**VGA Sequencer Index Register Bit Descriptions**

Bit	Name	Description
7:3	RSVD	<b>Reserved.</b>
2:0	INDEX	<b>Index.</b>

#### 6.6.18.2 VGA Sequencer Data

Data Address 3C5h  
 Type R/W  
 Reset Value xxh

**VGA Sequencer Data Register Bit Descriptions**

Bit	Name	Description
7:0	DATA	<b>Data.</b>

#### 6.6.18.3 VGA Reset

Index 00h  
 Type R/W  
 Reset Value 00h

**VGA Reset Register Bit Descriptions**

Bit	Name	Description
7:2	RSVD	<b>Reserved.</b>
1:0	DIS_EN	<b>Enable Display.</b> Both these bits should be set to 1 (value = 11) to enable display of the VGA screen image. If either of these bits are 0, the display is blanked. The VGA continues to respond to I/O and memory accesses.

**6.6.18.4 VGA Clocking Mode**

Index            01h  
 Type            R/W  
 Reset Value    02h

**VGA Clocking Mode Register Bit Descriptions**

Bit	Name	Description
7:6	RSVD	<b>Reserved.</b>
5	SCREEN_OFF	<b>Screen Off.</b> Setting this bit to a 1 blanks the screen while maintaining the HSYNC and VSYNC signals. This is intended to allow the CPU full access to the memory bandwidth. This bit must be 0 for the display image to be visible.
4	RSVD	<b>Not Supported.</b> (Shift4)
3	DCLK_DIV2	<b>Dot Clock Divide By 2.</b> When set to 1, the incoming pixel clock is divided by two to form the actual Dot clock. When 0, the incoming pixel clock is used unchanged.
2	RSVD	<b>Not Supported.</b> (Shift Load)
1	RSVD	<b>Reserved.</b> Always 1.
0	CHAR_WIDTH	<b>8-Dot Character Width.</b> When set to a 1, the character cells in text mode are eight pixels wide. When set to 0, the character cells are nine pixels wide. The 9th pixel is equal to the 8th pixel for character codes C0h-DFh (the line graphics character codes), and is 0 (background) for all other codes.

**6.6.18.5 VGA Map Mask**

Index            02h  
 Type            R/W  
 Reset Value    00h

These bits enable (bit = 1) writing to their corresponding bytes in each DWORD of the frame buffer (i.e., EM3 enables byte 3, EM2 enables byte 2, etc.). The four maps or planes correspond to the four bytes in each DWORD of the frame buffer. Reads to all maps are always enabled, and are unaffected by these bits.

**VGA Map Mask Register Bit Descriptions**

Bit	Name	Description
7:4	RSVD	<b>Reserved.</b>
3	EM3	<b>Enable Map 3.</b>
2	EM2	<b>Enable Map 2.</b>
1	EM1	<b>Enable Map 1.</b>
0	EM0	<b>Enable Map 0.</b>

### 6.6.18.6 VGA Character Map Select

Index	03h
Type	R/W
Reset Value	xxh

Character Map A (bits [5,3:2]) and Character Map B (bits [4,1:0]) determine which font tables are used when displaying a character in text mode. When bit 3 of the character's attribute = 1, Character Map A is used; when bit 3 of the character's attribute = 0, Character Map B is used. The font tables are stored in the 64 KB in map 2. There are eight font tables. The character map codes select the font tables as shown in Table 6-52.

#### VGA Character Map Select Register Bit Descriptions

Bit	Name	Description
7:6	RSVD	<b>Reserved.</b> Write as read.
5	CHAR_AZ	<b>Character Map A bit 2.</b>
4	CHAR_BZ	<b>Character Map B bit 2.</b>
3:2	CHAR_A	<b>Character Map A bits 1:0.</b>
1:0	CHAR_B	<b>Character Map B bits 1:0.</b>

Table 6-52. Font Table

Code	Font Table Location in Map 2	Code	Font Table Location in Map 2
0	8 KB Block 0	4	8 KB Block 1
1	8 KB Block 2	5	8 KB Block 3
2	8 KB Block 4	6	8 KB Block 5
3	8 KB Block 6	7	8 KB Block 7

### 6.6.18.7 VGA Memory Mode

Index	04h
Type	R/W
Reset Value	02h

#### VGA Memory Mode Register Bit Descriptions

Bit	Name	Description
7:4	RSVD	<b>Reserved.</b>
3	CHAIN4	<b>Chain4.</b> When set to a 1, CPU address bits 1 and 0 are used to select the map or plane in the frame buffer DWORD. For example, if CPU A1:A0 = 3, then map 3 is selected. If CPU A1:A0 = 1, then map 1 is selected. If Chain4 is 0, then the frame buffer addressing is controlled by the CHAIN2 (bit 2).
2	CHAIN2	<b>Chain2.</b> When set to a 0, CPU address bit 0 selects between frame buffer maps 0 and 1, or maps 2 and 3, depending on the value in the graphics controller Read Map Select field (Index 04h[1:0]). For example, if CPU A0 is 0, then map 0 (or 2) is selected.
1	EXT_MEM	<b>Extended Memory.</b> This bit should always be set to a 1. It is a throwback to EGA where the standard frame buffer size was 64 KB and was upgradeable to 256 KB. VGA always has (at least) 256 KB.
0	RSVD	<b>Reserved.</b>



### 6.6.19 VGA CRT Controller Registers

The CRTC registers are accessed by writing an index value to the CRTC Index register (3B4h or 3D4h) and reading or writing the register using the CRTC Data register (3B5h or 3D5h). See the description of the I/O Address Select bit in the Miscellaneous Output register (Section 6.6.17.1 on page 356) for more information on the I/O address of the CRTC registers. The CRT timings are controlled by the CRT Controller registers when the VGA is active. Various third-party VGA adapters implement these registers differently, and so different cards can produce different timings with the same settings. The settings shown in Table 6-53 are recommended for various VGA modes when programming the CRTC registers.

**Table 6-53. CRTC Register Settings**

Index	VGA Mode														
	00	01	02	03	04	05	06	07	0D	0E	0F	10	11	12	13
0	2D	2D	5F	5F	2D	2D	5F	5F	2D	5F	5F	5F	5F	5F	5F
1	27	27	4F	4F	27	27	4F	4F	27	4F	4F	4F	4F	4F	4F
2	28	28	50	50	28	28	50	50	28	50	50	50	50	50	50
3	90	90	82	82	90	90	82	82	90	82	82	82	82	82	82
4	29	29	51	51	29	29	51	51	29	51	51	51	51	51	51
5	8E	8E	9E	9E	8E	8E	9E	9E	8E	9E	9E	9E	9E	9E	9E
6	BF	BF	BF	BF	BF	BF	BF	BF	BF	BF	BF	BF	0B	0B	BF
7	1F	1F	1F	1F	1F	1F	1F	1F	1F	1F	1F	1F	3E	3E	1F
8	00	00	00	00	00	00	00	00	00	00	00	00	00	00	00
9	4F	4F	4F	4F	C1	C1	C1	4F	C0	C0	40	40	40	40	41
A	0D	0D	0D	0D	00	00	00	0D	00	00	00	00	00	00	00
B	0E	0E	0E	0E	00	00	00	0E	00	00	00	00	00	00	00
C	00	00	00	00	00	00	00	00	00	00	00	00	00	00	00
D	00	00	00	00	00	00	00	00	00	00	00	00	00	00	00
E	00	00	00	00	00	00	00	00	00	00	00	00	00	00	00
F	00	00	00	00	00	00	00	00	00	00	00	00	00	00	00
10	9B	9B	9B	9B	9B	9B	9B	9B	9B	9B	83	83	E9	E9	9B
11	8D	8D	8D	8D	8D	8D	8D	8D	8D	8D	85	85	8B	8B	8D
12	8F	8F	8F	8F	8F	8F	8F	8F	8F	8F	5D	5D	DF	DF	8F
13	14	14	28	28	14	14	28	28	14	28	28	28	28	28	28
14	1F	1F	1F	1F	00	00	00	0F	00	00	0F	0F	00	00	40
15	97	97	97	97	97	97	97	97	97	97	65	65	E7	E7	98
16	B9	B9	B9	B9	B9	B9	B9	B9	B9	B9	B9	B9	04	04	B9
17	A3	A3	A3	A3	A2	A2	C2	A3	E3	E3	E3	E3	C3	E3	A3
18	FF	FF	FF	FF	FF	FF	FF	FF	FF	FF	FF	FF	FF	FF	FF

**Note:** The Extended VGA Registers are accessed through the CRTC interface. This section only discusses the base VGA registers, however. See Section 6.6.23 "VGA Block Extended Registers" on page 384 for more information on the extended registers.

Table 6-54. CRTC Registers Summary

Index	Type	Register	Reset Value	Reference
--	R/W	CRTC Index	00h	Page 362
--	R/W	CRTC Data	00h	Page 363
00h	R/W	Horizontal Total	00h	Page 363
01h	R/W	Horizontal Display Enable End	00h	Page 363
02h	R/W	Horizontal Blank Start	00h	Page 363
03h	R/W	Horizontal Blank End	00h	Page 364
04h	R/W	Horizontal Sync Start	00h	Page 364
05h	R/W	Horizontal Sync End	00h	Page 364
06h	R/W	Vertical Total	00h	Page 365
07h	R/W	Overflow	xxh	Page 365
08h	R/W	Preset Row Scan	00h	Page 365
09h	R/W	Maximum Scan Line	00h	Page 366
0Ah	R/W	Cursor Start	00h	Page 366
0Bh	R/W	Cursor End	00h	Page 367
0Ch	R/W	Start Address High	00h	Page 367
0Dh	R/W	Start Address Low	00h	Page 367
0Eh	R/W	Cursor Location High	00h	Page 367
0Fh	R/W	Cursor Location Low	00h	Page 368
10h	R/W	Vertical Sync Start	00h	Page 368
11h	R/W	Vertical Sync End	00h	Page 368
12h	R/W	Vertical Display Enable End	00h	Page 369
13h	R/W	Offset	00h	Page 369
14h	R/W	Underline Location	00h	Page 369
15h	R/W	Vertical Blank Start	00h	Page 370
16h	R/W	Vertical Blank End	00h	Page 370
17h	R/W	CRTC Mode Control	00h	Page 370
18h	R/W	Line Compare	00h	Page 372
22h	R/W	CPU Data Latch State	00h	Page 372
24h	R/W	Attribute Index/Data FF State	00h	Page 372
26h	R/W	Attribute Index State	xxh	Page 373

#### 6.6.19.1 CRTC Index

Index Address 3B4h or 3D4h  
 Type R/W  
 Reset Value 00h

#### CRTC Index Register Bit Descriptions

Bit	Name	Description
7	RSVD	Reserved.
6:0	INDEX	Index.

**6.6.19.2 CRTC Data**

Data Address 3B5h or 3D5h  
 Type R/W  
 Reset Value 00h

**CRTC Data Register Bit Descriptions**

Bit	Name	Description
7	RSVD	<b>Reserved.</b>
6:0	DATA	<b>Data.</b>

**6.6.19.3 Horizontal Total**

Index 00h  
 Type R/W  
 Reset Value 00h

**Horizontal Total Register Bit Descriptions**

Bit	Name	Description
7:0	H_TOTAL	<b>Horizontal Total.</b> This value specifies the number of character clocks per horizontal scan line minus 5. It determines the horizontal line rate/period.

**6.6.19.4 Horizontal Display Enable End**

Index 01h  
 Type R/W  
 Reset Value 00h

**Horizontal Display Enable End Register Bit Descriptions**

Bit	Name	Description
7:0	H_DISP_END	<b>Horizontal Display Enable End.</b> This value specifies the number of displayed characters minus 1. It determines the width of the horizontal display enable signal.

**6.6.19.5 Horizontal Blank Start**

Index 02h  
 Type R/W  
 Reset Value 00h

**Horizontal Blank Start Register Bit Descriptions**

Bit	Name	Description
7:0	H_BLANK_ST	<b>Horizontal Blank Start.</b> This value specifies the character position on the line where the horizontal blanking signal goes active.

**6.6.19.6 Horizontal Blank End**

Index           03h  
 Type            R/W  
 Reset Value    00h

**Horizontal Blank End Register Bit Descriptions**

Bit	Name	Description
7	RSVD	<b>Reserved.</b> Set to 1.
6:5	DISPEN_SKEW	<b>Display Enable Skew Control.</b> This value is a binary encoded value that specifies how many character clocks to skew the horizontal display enable signal by (0 character clocks - 3 character clocks) before it is sent to the attribute controller. This field is used to accommodate differences in the length of the video pipeline (frame buffer to pixel output) in various text and graphics modes.
4:0	H_BLANK_END [4:0]	<b>Horizontal Blank End Register Bits [4:0].</b> This 6-bit value is a compare target for the character count where the horizontal blank signal ends. Bit 5 of this value is in the Horizontal Sync End register (Index 05h[7]). Note that not all horizontal counter bits are compared, which can create aliased compares depending upon the binary values involved in the count range and compare values.

**6.6.19.7 Horizontal Sync Start**

Index           04h  
 Type            R/W  
 Reset Value    00h

**Horizontal Sync Start Register Bit Descriptions**

Bit	Name	Description
7:0	H_SYNC_ST	<b>Horizontal Sync Start.</b> This value specifies the character position where the horizontal sync pulse starts.

**6.6.19.8 Horizontal Sync End**

Index           05h  
 Type            R/W  
 Reset Value    00h

**Horizontal Sync End Register Bit Descriptions**

Bit	Name	Description
7	H_BLANK_END5	<b>Horizontal Blank End bit 5.</b> See H_BLANK_END[4:0] bit description (Index 03h[4:0]).
6:5	RSVD	<b>Not Implemented.</b> (HSync Delay).
4:0	H_SYNC_END	<b>Horizontal Sync End.</b> These bits represent the low five bits of the character position where the horizontal sync signal ends.

**6.6.19.9 Vertical Total**

Index 06h  
 Type R/W  
 Reset Value 00h

**Vertical Total Register Bit Descriptions**

Bit	Name	Description
7:0	V_TOTAL[7:0]	<b>Vertical Total Register Bits [7:0].</b> This is the low eight bits of a value that specifies the total number of scan lines on the screen minus 2. This value includes the blanking area and determines the vertical refresh rate. The high two bits of this value are in the Overflow register (Index 07h[5,1]).

**6.6.19.10 Overflow**

Index 07h  
 Type R/W  
 Reset Value xxh

These are the high-order bits for several of the vertical programming values. See the descriptions of the respective vertical registers for descriptions of these fields.

**Overflow Register Bit Descriptions**

Bit	Name	Description
7	V_SYNC_ST9	<b>Vertical Sync Start Bit 9.</b> See V_SYNC_ST[7:0] bit description (Index 10h[7:0]). V_SYNC_ST8 is located at bit 2
6	V_DISP_EN_END9	<b>Vertical Display Enable End Bit 9.</b> See V_DISP_END[7:0] bit description (Index 12h[7:0]). V_DISP_END8 is located at bit 1
5	V_TOTAL9	<b>Vertical Total Bit 9.</b> See V_TOTAL[7:0] bit description (Index 06h[7:0]). V_TOTAL8 is located at bit 0.
4	LINE_COMP8	<b>Line Compare Bit 8.</b> See LINE_COMP[7:0] bit description (Index 18h[7:0]). LINE_COMP9 is located at Index 09h[6].
3	V_BLANK_ST8	<b>Vertical Blank Start Bit 8.</b> See V_BLANK_ST[7:0] bit description (Index 15h[7:0]). V_BLANK_ST9 is located at Index 09h[5].
2	V_SYNC_ST8	<b>Vertical Sync Start Bit 8.</b> See V_SYNC_ST[7:0] bit description (Index 10h[7:0]). V_SYNC_ST9 is located at bit 7.
1	V_DISP_EN_END8	<b>Vertical Display Enable End Bit 8.</b> See V_DISP_END[7:0] bit description (Index 12h[7:0]). V_DISP_END9 is located at bit 6.
0	V_TOTAL8	<b>Vertical Total Bit 8.</b> See VTOTAL[7:0] bit description (Index 06h[7:0]). V_TOTAL9 is located at bit 5.

**6.6.19.11 Preset Row Scan**

Index 08h  
 Type R/W  
 Reset Value 00h

**Preset Row Scan Register Bit Descriptions**

Bit	Name	Description
7	RSVD	<b>Reserved.</b>

## Preset Row Scan Register Bit Descriptions

Bit	Name	Description
6:5	BYPE_PAN	<b>Byte Panning.</b> This value causes the pixel data stream to be fetched zero, one, two, or three character positions early for use with pel panning in the attribute controller. This field is used when the video serializers are chained together (by two or by four).
4:0	ROW_SCAN	<b>Starting Row Scan.</b> This specifies the value loaded into the row scan counter on the first text line of the screen. Changing this value in text modes allows the screen to be scrolled on a scan line basis rather than a text line basis. The starting row scan count for all subsequent scan lines is 0.

## 6.6.19.12 Maximum Scan Line

Index           09h  
 Type           R/W  
 Reset Value   00h

## Maximum Scan Line Register Bit Descriptions

Bit	Name	Description
7	DBL_SCAN	<b>Double Scan.</b> When this bit is set to a 1, the row scan counter increments every other scan line. When this bit is cleared to 0, the row scan counter increments on every scan line. This bit is used to make 200 line text modes occupy 400 physical scan lines on the screen.
6	LN_CMP9	<b>Line Compare Register Bit 9.</b> See LINE_COMP[7:0] bit description (Index 18h[7:0]). LINE_COMP8 is located at Index 07h[4].
5	V_BLANK_ST9	<b>Vertical Blank Start Register Bit 9.</b> See V_BLANK_ST[7:0] bit description (Index 15h[7:0]). V_BLANK_ST8 is located at Index 09h[3].
4:0	MAX_LINE	<b>Maximum Scan Line.</b> This field specifies the number of scan lines per character row minus 1. The row scan counter will count up to this value then go to 0 for the next character row.

## 6.6.19.13 Cursor Start

Index           0Ah  
 Type           R/W  
 Reset Value   00h

## Cursor Start Register Bit Descriptions

Bit	Name	Description
7:6	RSVD	<b>Reserved.</b>
5	CURS_OFF	<b>Cursor Off.</b> When set to 1, the cursor is turned off and will not appear on the screen. When this bit is 0, the cursor is displayed. This bit is only applicable in text modes.
4:0	CURS_ST	<b>Cursor Start.</b> This field specifies the first scan line in the character box where the cursor is displayed. If this value is greater than the Cursor End value (CURS_END, Index 0Bh[4:0]), then no cursor is displayed. If this value is equal to the CURS_END value, then the cursor occupies a single scan line.

**6.6.19.14 Cursor End**

Index           0Bh  
 Type           R/W  
 Reset Value   00h

**Cursor End Register Bit Descriptions**

Bit	Name	Description
7	RSVD	<b>Reserved.</b>
6:5	CURS_SKEW	<b>Cursor Skew.</b> This field allows the cursor to be skewed by zero, one, two, or three character positions to the right.
4:0	CURS_END	<b>Cursor End.</b> This field specifies the last scan line in the character box where the cursor is displayed. See CURS_ST bit descriptions (Index 0Ah[4:0]) for more information.

**6.6.19.15 Start Address High**

Index           0Ch  
 Type           R/W  
 Reset Value   00h

**Start Address High Register Bit Descriptions**

Bit	Name	Description
7:0	ST_ADDR_HI	<b>Start Address Register Bits [15:8].</b> Together with the register (ST_ADDR_LOW, Index 0Dh[7:0]), this value specifies the frame buffer address used at the beginning of a screen refresh. It represents the upper left corner of the screen.

**6.6.19.16 Start Address Low**

Index           0Dh  
 Type           R/W  
 Reset Value   00h

**Start Address Low Register Bit Descriptions**

Bit	Name	Description
7:0	ST_ADDR_LOW	<b>Start Address Register Bits [7:0].</b> Together with the register (ST_ADDR_HI, Index 0Ch[7:0]), this value specifies the frame buffer address used at the beginning of a screen refresh. It represents the upper left corner of the screen.

**6.6.19.17 Cursor Location High**

Index           0Eh  
 Type           R/W  
 Reset Value   00h

**Cursor Location High Register Bit Descriptions**

Bit	Name	Description
7:0	CURS_HI	<b>Cursor Location Register Bits [15:8].</b> Together with the register (CURS_LOW, Index 0Fh[7:0]), this value specifies the frame buffer address where the cursor is displayed in text mode. The cursor will appear at the character whose memory address corresponds to this value.

**6.6.19.18 Cursor Location Low**

Index 0Fh  
 Type R/W  
 Reset Value 00h

**Cursor Location Low Register Bit Descriptions**

Bit	Name	Description
7:0	CURS_LOW	<b>Cursor Location Register Bits [7:0].</b> Together with the register (CURS_HI, Index 0Eh[7:0]), this value specifies the frame buffer address where the cursor is displayed in text mode. The cursor will appear at the character whose memory address corresponds to this value.

**6.6.19.19 Vertical Sync Start**

Index 10h  
 Type R/W  
 Reset Value 00h

**Vertical Sync Start Register Bit Descriptions**

Bit	Name	Description
7:0	VERT_SYNC_ST	<b>Vertical Sync Start Register Bits [7:0].</b> This value specifies the scan line number where the vertical sync signal will go active. This is a 10-bit value. Bits 9 and 8 are in the Overflow register (Index 07h[7,2]).

**6.6.19.20 Vertical Sync End**

Index 11h  
 Type R/W  
 Reset Value 00h

**Vertical Sync End Register Bit Descriptions**

Bit	Name	Description
7	WR_PROT	<b>Write-Protect Registers.</b> This bit is used to prevent old EGA programs from writing invalid values to the VGA horizontal timing registers. The LINE_COMP8 (Index 07h[4]) is not protected by this bit.
6	RSVD	<b>Not Implemented.</b> (Refresh Cycle Select)
5	RSVD	<b>Not Implemented.</b> (Enable Vertical Interrupt)
4	RSVD	<b>Not Implemented.</b> (Clear Vertical Interrupt)
3:0	V_SYNC_END	<b>Vertical Sync End Register Bits [3:0].</b> This field represents the low four bits of a compare value that specifies which scan line that the vertical sync signal goes inactive.



**6.6.19.21 Vertical Display Enable End**

Index 12h  
 Type R/W  
 Reset Value 00h

**Vertical Display Enable End Register Bit Descriptions**

Bit	Name	Description
7:0	V_DISP_EN_END	<b>Vertical Display Enable End Register Bits [7:0].</b> This is a 10-bit value that specifies the scan line where the vertical display enable signal goes inactive. It represents the number of active scan lines minus 1. Bits 9 and 8 of this value are in the Overflow register (Index 07h[6,1]).

**6.6.19.22 Offset**

Index 13h  
 Type R/W  
 Reset Value 00h

**Offset Register Bit Descriptions**

Bits	Name	Description
7:0	OFST	<b>Offset.</b> This field specifies the logical line width of the screen. This value (multiplied by two or four depending on the CRTIC clocking mode) is added to the starting address of the current scan line to get the starting address of the next scan line.

**6.6.19.23 Underline Location**

Index 14h  
 Type R/W  
 Reset Value 00h

**Underline Location Register Bit Descriptions**

Bit	Name	Description
7	RSVD	<b>Reserved.</b>
6	DW	<b>Doubleword Mode.</b> When this bit is a 1, CRTIC memory addresses are DWORD addresses, and the CRTIC refresh counter effectively increments by 4. When this bit is a 0, the address increment is determined by the Byte Mode bit in the CRTIC Mode Control register (Index 17h[6]).
5	RSVD	<b>Not Implemented.</b> (Count by 4)
4:0	UL	<b>Underline Location.</b> This field specifies the row scan value where the underline appears in the character box in text modes.

**6.6.19.24 Vertical Blank Start**

Index 15h  
 Type R/W  
 Reset Value 00h

**Vertical Blank Start Register Bit Descriptions**

Bit	Name	Description
7:0	V_BL_ST	<b>Vertical Blank Start Register Bits [7:0].</b> This is the low eight bits of a value that specifies the starting scan line of the vertical blank signal. This is a 10-bit value. Bit 8 is in the Overflow register (Index 07h[3]) and bit 9 is in the Maximum Scan Line register (Index 09h[5]).

**6.6.19.25 Vertical Blank End**

Index 16h  
 Type R/W  
 Reset Value 00h

**Vertical Blank End Register Bit Descriptions**

Bit	Name	Description
7:0	V_BL_END	<b>Vertical Blank End.</b> This value specifies the low eight bits of a compare value that represents the scan line where the vertical blank signal goes inactive.

**6.6.19.26 CRTC Mode Control**

Index 17h  
 Type R/W  
 Reset Value 00h

**CRTC Mode Control Register Bit Descriptions**

Bit	Name	Description
7	ENSYNC	<b>Enable Syncs.</b> When set to 1, this bit enables the horizontal and vertical sync signals. When 0, this bit holds both sync flip-flops reset.
6	BTMD	<b>Byte Mode.</b> If the DWORD mode bit (DW, Index 14h[6]) is 0, then this bit configures the CRTC addresses for byte addresses when set to 1, or WORD addresses when set to 0. If DW is set to 1, then this bit is ignored. See Table 6-55 on page 371 for information on the various CRTC addressing modes.
5	AW	<b>Address Wrap.</b> When the CRTC is addressing the frame buffer in Word Mode (Byte Mode = 0, DWORD Mode = 0) then this bit determines which address bit occupies the MA0 bit position of the address sent to the frame buffer memory. If Address Wrap = 0, CRTC address counter bit 13 occupies the MA0 position. If Address Wrap = 1, then CRTC address counter bit 15 is in the MA0 position. See Table 6-55 on page 371 for information on the various CRTC addressing modes.
4	RSVD	<b>Reserved.</b>
3	RSVD	<b>Not Implemented.</b> (Count by 2)
2	VCLK_SL	<b>VCLK Select.</b> This bit determines the clocking for the vertical portion of the CRTC. If this bit is 0, the horizontal sync signal clocks the vertical section. If this bit is 1, the horizontal sync divided by two clocks the vertical section.

## CRTC Mode Control Register Bit Descriptions (Continued)

Bit	Name	Description
1	SL_RSCBT	<b>Select Row Scan Bit.</b> This bit determines which CRTC signal appears on the MA14 address bit sent to the frame buffer memory. If this bit is a 0, bit 1 of the Row Scan counter appears on MA14. If this bit is a 1, then CRTC address counter bit 14, 13, or 12 appears on MA14. See Table 6-55 on page 371 for more information.
0	SL_A13	<b>Select A13.</b> This bit determines which CRTC signal appears on the MA13 address bit sent to the frame buffer memory. If this bit is a 0, bit 0 of the Row Scan counter appears on MA13. If this bit is a 1, then CRTC address counter bit 13, 12, or 11 appears on MA13. See Table 6-55 on page 371 for more information.

Table 6-55 illustrates the various frame buffer addressing schemes. In the table, MA<sub>x</sub> represents the frame buffer memory address signals, A<sub>x</sub> represents the CRTC address counter signals, RS<sub>x</sub> represents row scan counter output bits. The binary value in the column headings is a concatenation of the DWORD Mode and Byte Mode bits. (i.e., {DWORD Mode, ByteMode} in verilog.)

Table 6-55. CRTC Memory Addressing Modes

Frame Buffer Memory Address Bit	Byte Mode (01)	Word Mode (00)	DWORD Mode (1X)
MA0	A0	A15 or A13	A12
MA1	A1	A0	A13
MA2	A2	A1	A0
MA3	A3	A2	A1
MA4	A4	A3	A2
MA5	A5	A4	A3
MA6	A6	A5	A4
MA7	A7	A6	A5
MA8	A8	A7	A6
MA9	A9	A8	A7
MA10	A10	A9	A8
MA11	A11	A10	A9
MA12	A12	A11	A10
MA13	A13 or RS0	A12 or RS0	A11 or RS0
MA14	A14 or RS1	A13 or RS1	A12 or RS1
MA15	A15	A14	A13

**6.6.19.27 Line Compare**

Index            18h  
 Type            R/W  
 Reset Value    00h

**Line Compare Register Bit Descriptions**

Bit	Name	Description
7:0	LINE_COMP[7:0]	<b>Line Compare Register Bits [7:0].</b> This value specifies the low eight bits of a compare value that represents the scan line where the CRTIC frame buffer address counter is reset to 0. This can be used to create a split screen by using the Start Address registers to specify a non-zero location at which to begin the screen image. The lower portion of the screen (starting at frame buffer address 0) is immune to screen scrolling (and pel panning as specified in the Attribute Mode Control register (Index 10h). Line Compare is a 10-bit value. Bit 8 is located in the Overflow register (Index 07h[4]) and bit 9 is in the Maximum Scan Line register (Index 09h[6]).

**6.6.19.28 CPU Data Latch State**

Index            22h  
 Type            RO  
 Reset Value    00h

**CPU Data Latch State Register Bit Descriptions**

Bit	Name	Description
7:0	DLV	<b>Data Latch Value.</b> This read only field returns a byte of the CPU data latches and can be used in VGA save/restore operations. The graphics controller's Read Map Select field (Index 04h[1:0]) specifies which byte/map (0-3) is returned.

**6.6.19.29 Attribute Index/Data FF State**

Index            24h  
 Type            RO  
 Reset Value    00h

**Attribute Index/Data FF State Register Bit Descriptions**

Bit	Name	Description
7	FFST	<b>FF State.</b> This read only bit indicates the state of the attribute controller index/data flip-flop. When this bit is 0, the next write to Index 3C0h will write an index value; when this bit is 1, the next write to Index 3C0h will write a data register value.
6:0	RSVD	<b>Reserved.</b>

**6.6.19.30 Attribute Index State**

Index            26h  
 Type            RO  
 Reset Value    xxh

**Attribute Index State Register Bit Descriptions**

Bit	Name	Description
7:6	RSVD	<b>Reserved.</b>
5:0	ATT_IN_VA	<b>Attribute Index Value.</b> This read only value indicates the value of Attribute Index register bits [5:0] (Index 3C0h).

**6.6.20 VGA Graphics Controller Registers**

The graphics controller registers are accessed by writing an index value to the Graphics Controller Index register (Index Address 3CEh) and reading or writing the register using the Graphics Controller Data register (Data Address 3CFh).

**Table 6-56. Graphics Controller Registers Summary**

Index	Type	Register	Reset Value	Reference
--	R/W	VGA Graphics Controller Index	xxh	Page 373
--	R/W	VGA Graphics Controller Data	xxh	Page 374
00h	R/W	VGA Set/Reset	xxh	Page 374
01h	R/W	VGA Enable Set/Reset	xxh	Page 374
02h	R/W	VGA Color Compare	xxh	Page 375
03h	R/W	VGA Data Rotate	xxh	Page 375
04h	R/W	VGA Read Map Select	xxh	Page 376
05h	R/W	VGA Graphics Mode	xxh	Page 376
06h	R/W	VGA Miscellaneous	xxh	Page 377
07h	R/W	VGA Color Don't Care	xxh	Page 378
08h	R/W	VGA Bit Mask	xxh	Page 378

**6.6.20.1 VGA Graphics Controller Index**

Index Address    3CEh  
 Type            R/W  
 Reset Value    xxh

**VGA Graphics Controller Index Register Bit Descriptions**

Bit	Name	Description
7:4	RSVD	<b>Reserved.</b>
3:0	INDEX	<b>Index.</b>

**6.6.20.2 VGA Graphics Controller Data**

Data Address 3CFh  
 Type R/W  
 Reset Value xxh

**VGA Graphics Controller Data Register Bit Descriptions**

Bit	Name	Description
7:4	RSVD	<b>Reserved.</b>
3:0	DATA	<b>Data.</b>

**6.6.20.3 VGA Set/Reset**

Index 00h  
 Type R/W  
 Reset Value xxh

Bits [3:0] allow bits in their respective maps to be set or reset through write modes 0 or 3. See Section 6.5.5.3 "Write Modes" on page 290 for more information.

**VGA Set/Reset Register Bits Bit Descriptions**

Bit	Name	Description
7:4	RSVD	<b>Reserved.</b>
3	SR_MP3	<b>Set/Reset Map 3.</b>
2	SR_MP2	<b>Set/Reset Map 2.</b>
1	SR_MP1	<b>Set/Reset Map 1.</b>
0	SR_MP0	<b>Set/Reset Map 0</b>

**6.6.20.4 VGA Enable Set/Reset**

Index 01h  
 Type R/W  
 Reset Value xxh

Bits [3:0] enable the Set/Reset function for their respective maps in write mode 0. See Section 6.5.5.3 "Write Modes" on page 290 for more information.

**VGA Enable Set/Reset Register Bit Descriptions**

Bit	Name	Description
7:4	RSVD	<b>Reserved.</b>
3	EN_SR_MP3	<b>Enable Set/Reset Map 3.</b>
2	EN_SR_MP2	<b>Enable Set/Reset Map 2.</b>
1	EN_SR_MP1	<b>Enable Set/Reset Map 1.</b>
0	EN_SR_MP0	<b>Enable Set/Reset Map 0.</b>

**6.6.20.5 VGA Color Compare**

Index            02h  
 Type            R/W  
 Reset Value    xxh

Bits [3:0] specify a compare value that allows the CPU to compare pixels in planar modes. Read mode 1 performs a comparison based on these bits combined with the Color Don't Care bits. Data returned will contain a 1 in each one of the eight pixel positions where a color match is found. See the description of read modes (Section 6.5.5.4 on page 291) for more information.

**VGA Color Compare Register Bit Descriptions**

Bit	Name	Description
7:4	RSVD	<b>Reserved.</b>
3	CO_CM_MP3	<b>Color Compare Map 3.</b>
2	CO_CM_MP2	<b>Color Compare Map 2.</b>
1	CO_CM_MP1	<b>Color Compare Map 1.</b>
0	CO_CM_MP0	<b>Color Compare Map 0.</b>

**6.6.20.6 VGA Data Rotate**

Index            03h  
 Type            R/W  
 Reset Value    xxh

**VGA Data Rotate Bit Descriptions Bit Descriptions**

Bit	Name	Description
7:5	RSVD	<b>Reserved.</b>
4:3	WROP	<b>Write Operation.</b> Data written to the frame buffer by the CPU can be logically combined with data already in the CPU data latches. 00: Copy (CPU data written unmodified). 01: CPU data ANDed with latched data. 10: CPU data ORed with latched data. 11: CPU data XORed with latched data. See the description of write modes (Section 6.5.5.3 on page 290) for more information.
2:0	ROTCNT	<b>Rotate Count.</b> This value is used to rotate the CPU data before it is used in write modes 0 and 3. The CPU data byte written is rotated right, with low bits wrapping to the high bit positions. See the description of write modes (Section 6.5.5.3 on page 290) for more information.

**6.6.20.7 VGA Read Map Select**

Index 04h  
 Type R/W  
 Reset Value xxh

**VGA Read Map Select Register Bit Descriptions**

Bit	Name	Description
7:2	RSVD	<b>Reserved.</b>
1:0	R_MP_SL	<p><b>Read Map Select.</b> This field specifies which map CPU read data is taken from in read mode 0. In Odd/Even modes (specified by the Odd/Even bit in the Graphics Mode register, Index 05h[4]) bit 1 of this field specifies which pair of maps returns data.</p> <p>When bit 1 is 0, data is returned from maps 0 and 1. When bit 1 is 1, data is returned from maps 2 and 3. The CPU read address bit A0 determines which byte is returned (low or high) in Odd/Even modes. In non-Odd/Even modes, these bits (both bits [1:0]) specify the map to read (0, 1, 2, or 3) and the CPU accesses data sequentially within the specified map.</p>

**6.6.20.8 VGA Graphics Mode**

Index 05h  
 Type R/W  
 Reset Value xxh

**VGA Graphics Mode Register Bit Descriptions**

Bit	Name	Description
7	RSVD	<b>Reserved.</b>
6	256_CM	<p><b>256 Color Mode.</b> When set to a 1, this bit configures the video serializers in the graphics controller for the 256 color mode (BIOS mode 13h). When this bit is 0, the Shift Register Mode bit (bit 5) controls the serializer configuration.</p>
5	SH_R_MD	<p><b>Shift Register Mode.</b> When set to a 1, this bit configures the video serializers for BIOS modes 4 and 5. When this bit is 0, the serializers are taken in parallel (i.e., configured for 4-bit planar mode operation).</p> <p>Note that the serializers are also wired together serially so that map 3 bit 7 feeds map 2 bit 0, map 2 bit 7 feeds map 1 bit 0, and map 1 bit 7 feeds map 0 bit 0. This allows for a 32-pixel 1 bit-per-pixel serializer to be used. For this configuration, color planes 1, 2, and 3 should be masked off using the Color Plane Enable register (Attribute Controller, Index 12h, on page 381.)</p>
4	ODD_EVEN	<p><b>Odd/Even.</b> When this bit is set to 1, CPU address bit A0 will select between maps 0 and 1 or maps 2 and 3 depending on the state of the Read Map Select field (Index 04h[1:0]). When this bit is 0, the CPU accesses data sequentially within a map. This bit is equivalent to the Odd/Even bit in the VGA Miscellaneous register (Index 06h[2]), but is inverted in polarity from that bit.</p>
3	RD_MD	<p><b>Read Mode.</b> This bit determines what is returned to the CPU when it reads the frame buffer. When this bit is 1, the result of a color compare operation is returned. The eight bits in the CPU read data contain a 1 in each pixel position where the color compare operation was true, and a 0 where the operation was false. When this bit is 0, frame buffer map data is returned.</p>
2	RSVD	<b>Reserved.</b>



## VGA Graphics Mode Register Bit Descriptions

Bit	Name	Description
1:0	WR_MD	<p><b>Write Mode.</b> This field specifies how CPU data is written to the frame buffer. Note that the Write Operation field in the VGA Data Rotate register (Index 03h[4:3]) specifies how CPU data is combined with data in the data latches for write modes 0, 2, and 3.</p> <p>00: Write Mode 0: CPU data is rotated by the count in the VGA Data Rotate register. Each map enabled by the VGA Map Mask Register (Index 02h) is written by the rotated CPU data combined with the latch data (if set/reset is NOT enabled for that map) or by the map's corresponding set/reset bit replicated across the 8-bit byte (if set/reset IS enabled for that map). The VGA Bit Mask Register (Index 08h) is used to protect individual bits in each map from being updated.</p> <p>01: Write Mode 1: Each map enabled by the VGA Map Mask Register is written with its corresponding byte in the data latches.</p> <p>10: Write Mode 2: CPU data is replicated for each map and combined with the data latches and written to memory. The VGA Bit Mask Register (Index 08h) is used to protect individual bits in each map from being updated.</p> <p>11: Write Mode 3: Each map is written with its corresponding Set/Reset bit replicated through a byte (Enable Set/Reset is ignored). The CPU data is rotated and ANDed with the VGA Bit Mask Register (Index 08h). The resulting mask is used to protect individual bits in each map.</p>

## 6.6.20.9 VGA Miscellaneous

Index	06h
Type	R/W
Reset Value	xxh

## VGA Miscellaneous Register Bit Descriptions

Bit	Name	Description
7:4	RSVD	<b>Reserved.</b>
3:2	MEM_MAP	<p><b>Memory Map.</b> This field controls the address mapping of the frame buffer in the CPU memory space.</p> <p>00: Memory Map 0: A0000 to BFFFF (128 KB)  01: Memory Map 1: A0000 to AFFFF (64 KB)  10: Memory Map 2: B0000 to B7FFF (32 KB)  11: Memory Map 3: B8000 to BFFFF (32 KB)</p>
1	ODD_EVEN	<b>Odd/Even.</b> When set to 1, this bit replaces the CPU A0 address bit with a higher order bit when addressing the frame buffer. Odd maps are then selected when CPU A0 = 1, and even maps selected when CPU A0 = 0.
0	GPH_MD	<p><b>Graphics Mode.</b></p> <p>0: Text mode operation.  1: Graphics mode operation.</p>

### 6.6.20.10 VGA Color Don't Care

Index 07h  
Type R/W  
Reset Value xxh

#### VGA Color Don't Care Register Bit Descriptions

Bit	Name	Description
7:4	RSVD	<b>Reserved.</b>
3	CM_PR3	<b>Compare Map 3.</b> This bit enables (bit = 1) or excludes (bit = 0) map 3 from participating in a color compare operation.
2	CM_PR2	<b>Compare Map 2.</b> This bit enables (bit = 1) or excludes (bit = 0) map 2 from participating in a color compare operation.
1	CM_PR1	<b>Compare Map 1.</b> This bit enables (bit = 1) or excludes (bit = 0) map 1 from participating in a color compare operation.
0	CM_PR0	<b>Compare Map 0.</b> This bit enables (bit = 1) or excludes (bit = 0) map 0 from participating in a color compare operation.

### 6.6.20.11 VGA Bit Mask

Index 08h  
Type R/W  
Reset Value xxh

#### VGA Bit Mask Register Bit Descriptions

Bit	Name	Description
7:0	BT_MSK	<b>Bit Mask.</b> The bit mask is used to enable or disable writing to individual bits in each map. A 1 in the bit mask allows a bit to be updated, while a 0 in the bit mask writes the contents of the data latches back to memory, effectively protecting that bit from update. The data latches must be set by doing a frame buffer read in order for the masking operation to work properly. The bit mask is used in write modes 0, 2, and 3.

### 6.6.21 Attribute Controller Registers

The attribute controller registers are accessed by writing an index value to the Attribute Controller Index register (3C0h) and reading or writing the register using the Attribute Controller Data register (3C0h for writes, 3C1h for reads).

**Table 6-57. Attribute Controller Registers Summary**

Index	Type	Register	Reset Value	Reference
--	R/W	Attribute Controller Index/Data/Data	xxh	Page 379
00h-0Fh	R/W	EGA Palette	xxh	Page 379
10h	R/W	Attribute Mode Control	xxh	Page 380
11h	R/W	Overscan Color	xxh	Page 380
12h	R/W	Color Plane Enable	xxh	Page 381
13h	R/W	Horizontal Pel Panning	xxh	Page 381
14h	R/W	Color Select	xxh	Page 382

**6.6.21.1 Attribute Controller Index/Data**

Index Address	3C0h
Data Address	3C1h (R) 3C0h (W)
Type	R/W
Reset Value	xxh

The attribute controller registers do not have a separate address for writing index and data information. Instead, an internal flip-flop alternates between index and data registers. Reading Input Status Register 1 (3BAh or 3DAh) clears the flip-flop to the index state. The first write to 3C0h following a read from Input Status Register 1 will update the index register. The next write will update the selected data register. The next write specifies a new index, etc.

**Attribute Controller Index Register Bit Descriptions**

Bit	Name	Description
7:6	RSVD	<b>Reserved.</b>
5	INT_PAL_AD	<b>Internal Palette Address.</b> This bit determines whether the EGA palette is addressed by the video pixel stream (bit = 1) or by the Attribute Controller Index register (bit = 0). This bit should be set to 1 for normal VGA operation. CPU I/O accesses to the palette are disabled unless this bit is a 0.
4:0	DATA_RG_INX	<b>Data Register Index.</b> This field addresses the individual palette and data registers.

**6.6.21.2 EGA Palette**

Index	00h-0Fh
Type	R/W
Reset Value	xxh

**EGA Palette Register Bit Descriptions**

Bit	Name	Description
7:6	RSVD	<b>Reserved.</b>
5:0	COL_VAL	<b>Color Value.</b> Each of these 16 registers is used to expand the pixel value from the frame buffer (one, two, or four bits wide) into a 6-bit color value that is sent the video DAC. The EGA palette is "programmed out of the way" in 256 color mode. These registers can only be read or written when the Internal Palette Address bit in the Index register (3C0h) is 0.

**6.6.21.3 Attribute Mode Control**

Index 10h  
 Type R/W  
 Reset Value xxh

**Attribute Mode Control Register Bit Descriptions**

Bit	Name	Description
7	P5:4_SEL	<b>P5:4 Select.</b> When this bit is a 1, bits [5:4] of the 8-bit VGA pixel value are taken from bits [1:0] of the Color Select register (Index 14h). When a 0, bits [5:4] of the pixel are taken from bits [5:4] of the EGA palette output.
6	PEL_W	<b>Pel Width.</b> This bit is used in 256 color mode to shift four pixels through the attribute controller for each character clock. Clearing this bit shifts eight pixels for each character clock.
5	PEL_PAN_COMP	<b>Pel Panning Compatibility.</b> When this bit is a 1, the scan lines following a line compare are immune to the effects of the pel panning. When this bit is a 0, the entire screen is affected by pel panning, regardless of the line compare operation.
4	RSVD	<b>Reserved.</b>
3	EN_BLINK	<b>Enable Blink.</b> When this bit is a 1, attribute bit 7 is used to cause a character to blink (bit 7 = 1) or not (bit 7 = 0). When this bit is 0, attribute bit 7 is used as a background intensity bit.
2	EN_LGC	<b>Enable Line Graphics Codes.</b> When this bit is 0, the 9th Dot in 9-wide character modes is always set to the background color. When this bit is 1, the 9th Dot is equal to the foreground color for character codes C0h-DFh, which are the line graphics character codes.
1	MON_EMU	<b>Monochrome Emulation.</b> When this bit is a 1, the underline in 9-Dot mode extends for all nine Dots and an underlined phrase will have a continuous line under it. When this bit is 0, the underline is only active for eight Dots, and an underlined phrase will have a broken line under it.
0	GR_MODE	<b>Graphics Mode.</b> When this bit is 1, graphics mode is selected and pixel data from the frame buffer is used to produce the pixel stream. When this bit is 0, text mode is selected, and text attribute and font pattern information is used to produce the pixel stream.

**6.6.21.4 Overscan Color**

Index 11h  
 Type R/W  
 Reset Value xxh

**Overscan Color Register Bit Descriptions**

Bit	Name	Description
7:0	OVER_COLOR	<b>Overscan Color.</b> This value is output as the pixel value to the video DAC when the Display Enable signal from the CRTIC is inactive.

**6.6.21.5 Color Plane Enable**

Index 12h  
 Type R/W  
 Reset Value xxh

**Color Plane Enable Register Bit Descriptions**

Bit	Name	Description
7:4	RSVD	<b>Reserved.</b>
3	EN_CO_PN3	<b>Enable Color Plane 3.</b> This bit enables color plane 3. It is ANDed with its corresponding pixel bit and the resulting 4-bit value is used as the address into the EGA palette.
2	EN_CO_PN2	<b>Enable Color Plane 2.</b> This bit enables color plane 2. It is ANDed with its corresponding pixel bit and the resulting 4-bit value is used as the address into the EGA palette.
1	EN_CO_PN1	<b>Enable Color Plane 1.</b> This bit enables color plane 1. It is ANDed with its corresponding pixel bit and the resulting 4-bit value is used as the address into the EGA palette.
0	EN_CO_PN0	<b>Enable Color Plane 0.</b> This bit enables color plane 0. It is ANDed with its corresponding pixel bit and the resulting 4-bit value is used as the address into the EGA palette.

**6.6.21.6 Horizontal Pel Panning**

Index 13h  
 Type R/W  
 Reset Value xxh

**Horizontal Pel Panning Register Bit Descriptions**

Bit	Name	Description																																																																				
7:4	RSVD	<b>Reserved.</b>																																																																				
3:0	HPP	<p><b>Horizontal Pel Panning:</b> This field specifies how many pixels the screen image should be shifted to the left by.</p> <table border="1"> <thead> <tr> <th>Bits [3:0]</th> <th>Mode 13h Panning</th> <th>9-Wide Text Mode Panning</th> <th>Panning for All Other Modes</th> </tr> </thead> <tbody> <tr><td>0000</td><td>0</td><td>1</td><td>0</td></tr> <tr><td>0001</td><td>--</td><td>2</td><td>1</td></tr> <tr><td>0010</td><td>1</td><td>3</td><td>2</td></tr> <tr><td>0011</td><td>--</td><td>4</td><td>3</td></tr> <tr><td>0100</td><td>2</td><td>5</td><td>4</td></tr> <tr><td>0101</td><td>--</td><td>6</td><td>5</td></tr> <tr><td>0110</td><td>3</td><td>7</td><td>6</td></tr> <tr><td>0111</td><td>--</td><td>8</td><td>7</td></tr> <tr><td>1000</td><td>--</td><td>0</td><td>-</td></tr> <tr><td>1001</td><td>--</td><td>--</td><td>--</td></tr> <tr><td>1010</td><td>--</td><td>--</td><td>--</td></tr> <tr><td>1011</td><td>--</td><td>--</td><td>--</td></tr> <tr><td>1100</td><td>--</td><td>--</td><td>--</td></tr> <tr><td>1101</td><td>--</td><td>--</td><td>--</td></tr> <tr><td>1110</td><td>--</td><td>--</td><td>--</td></tr> <tr><td>1111</td><td>--</td><td>--</td><td>--</td></tr> </tbody> </table>	Bits [3:0]	Mode 13h Panning	9-Wide Text Mode Panning	Panning for All Other Modes	0000	0	1	0	0001	--	2	1	0010	1	3	2	0011	--	4	3	0100	2	5	4	0101	--	6	5	0110	3	7	6	0111	--	8	7	1000	--	0	-	1001	--	--	--	1010	--	--	--	1011	--	--	--	1100	--	--	--	1101	--	--	--	1110	--	--	--	1111	--	--	--
Bits [3:0]	Mode 13h Panning	9-Wide Text Mode Panning	Panning for All Other Modes																																																																			
0000	0	1	0																																																																			
0001	--	2	1																																																																			
0010	1	3	2																																																																			
0011	--	4	3																																																																			
0100	2	5	4																																																																			
0101	--	6	5																																																																			
0110	3	7	6																																																																			
0111	--	8	7																																																																			
1000	--	0	-																																																																			
1001	--	--	--																																																																			
1010	--	--	--																																																																			
1011	--	--	--																																																																			
1100	--	--	--																																																																			
1101	--	--	--																																																																			
1110	--	--	--																																																																			
1111	--	--	--																																																																			

**6.6.21.7 Color Select**

Index	14h
Type	R/W
Reset Value	xxh

**Color Select Register Bit Descriptions**

Bit	Name	Description
7:4	RSVD	<b>Reserved.</b>
3:2	P[7:6]	<b>P7 and P6.</b> These bits are used to provide the upper two bits of the 8-bit pixel value sent to the video DAC in all modes except the 256 color mode (mode 13h).
1:0	P[5:4]	<b>P5 and P4.</b> These bits are used to provide bits 5 and 4 of the 8-bit pixel value sent to the video DAC when the P5:4 Select bit is set in the Attribute Mode Control register (Index 10h[7]). In this case, they replace bits [5:4] coming from the EGA palette.

**6.6.22 Video DAC Registers**

Video DAC palette registers are accessed by writing the Palette Address register at the read or write address, then performing three reads or writes, one for each of the red, green, and blue color values. The video DAC provides an address increment feature that allows multiple sets of color triplets to be read or written without writing the Palette Address register again. To invoke this feature, simply follow the first triplet read/write with the next triplet read/write.

The original IBM video DAC behavior for read operations is:

- 1) CPU initiates a palette read by writing INDEX to I/O address 3C7h.
- 2) Video DAC loads a temporary register with the value stored at palette[INDEX].
- 3) Video DAC increments INDEX (INDEX = INDEX + 1).
- 4) CPU reads red, green, blue color values from temporary register at I/O address 3C9h.
- 5) Loop to step 2.

The original IBM video DAC behavior for write operations is:

- 1) CPU initiates a palette write by writing INDEX to I/O address 3C8h.
- 2) CPU writes red, green, blue color values to temporary DAC registers at I/O address 3C9h.
- 3) Video DAC stores the temporary register contents in palette[INDEX].
- 4) Video DAC increments INDEX (INDEX = INDEX + 1).
- 5) Loop to step 2.

**Table 6-58. Video DAC Registers Summary**

I/O Address	Type	Register	Reset Value	Reference
3C8h	RO	Palette Address (Write Mode)	00h	Page 383
3C7h	RO	Palette Address (Read Mode)	00h	Page 383
3C7h	RO	DAC State	00h	Page 383
3C9h	R/W	Palette Data	00h	Page 380
3C6h	R/W	Pel Mask	00h	Page 380

**6.6.22.1 Video DAC Palette Address**

Read Address 3C8h  
 Write Address 3C7h (Palette Read Mode)  
 3C8h (Palette Write Mode)  
 Type RO  
 Reset Value 00h

**Video DAC Palette Address Register Bit Descriptions**

Bit	Name	Description
7:0	ADDR	Palette Address.

**6.6.22.2 Video DAC State**

Read Address 3C7h  
 Write Address --  
 Type RO  
 Reset Value 00h

**Video DAC State Register Bit Descriptions**

Bit	Name	Description
7:2	RSVD	Reserved.
1:0	DAC_ST	<b>DAC State.</b> This register returns the DAC state for save/restore operations. If the last palette address write was to 3C7h (read mode), both bits are 1 (value = 11). If the last palette address write was to 3C8h (write mode), both bits are 0 (value = 00).

**6.6.22.3 Video DAC Palette Data**

Read Address 3C9h  
 Write Address 3C9h  
 Type R/W  
 Reset Value 00h

**Video DAC Palette Data Register Bit Descriptions**

Bit	Name	Description
7:6	RSVD	Reserved.
5:0	CO_CPN_VAL	<b>Color Component Value.</b> This is a 6-bit color component value that drives the video DAC for the appropriate color component when the current palette write address is used to address the video DAC in the pixel stream.

#### 6.6.22.4 Video DAC Palette Mask

Read Address 3C6h  
 Write Address 3C6h  
 Type R/W  
 Reset Value 00h

#### Video DAC Palette Mask Register Bit Descriptions

Bit	Name	Description
7:0	PAL_MSK	<b>Palette Mask.</b> These bits enable their respective color bits between the final VGA 8-bit pixel output and the DAC palette. The bits are ANDed with the incoming VGA pixel value and the result used to address the palette RAM.

#### 6.6.23 VGA Block Extended Registers

The Extended registers are accessed by writing an index value to the CRTC Index register (3B4h or 3D4h) and reading or writing the register using the CRTC Data register (3B5h or 3D5h). See the description of the I/O Address Select bit in the Section 6.6.17.1 "VGA Miscellaneous Output" on page 356 for more information on the I/O address of the CRTC registers.

**Table 6-59. Extended Registers Summary**

Index	Type	Register	Reset Value	Reference
0030h	R/W	ExtendedRegisterLock	FFh	Page 385
043h	R/W (Note 1)	ExtendedModeControl	00h	Page 385
044h	R/W (Note 1)	ExtendedStartAddress	00h	Page 385
047h	R/W (Note 1)	WriteMemoryAperture	00h	Page 386
048h	R/W (Note 1)	ReadMemoryAperture	00h	Page 386
060h	R/W (Note 1)	BlinkCounterCtl (for Sim/Test)	00h	Page 386
061h	R/W (Note 1)	BlinkCounter (for Sim/Test)	00h	Page 387
070h	R/W (Note 1)	VGALatchSavRes	00h	Page 387
071h	R/W (Note 1)	DACIFSavRes	00h	Page 387

Note 1. R/W when unlocked, RO otherwise (see Section 6.6.23.1 "ExtendedRegisterLock" for details).



**6.6.23.1 ExtendedRegisterLock**

CRTC Index 030h  
 Type R/W  
 Reset Value FFh

**ExtendedRegisterLock Register Bit Descriptions**

Bit	Name	Description
7:0	LOCK	<b>Lock.</b> A value of 4Ch unlocks the extended registers. Any other value locks the extended registers so they are read only. If the extended registers are currently locked, a read to this register will return FFh. If they are unlocked, a read will return 0.

**6.6.23.2 ExtendedModeControl**

CRTC Index 043h  
 Type R/W  
 Reset Value 00h

**ExtendedModeControl Register Bit Descriptions**

Bit	Name	Description
7:3	RSVD	<b>Reserved.</b>
2:1	VG_RG_MAP	<b>DC Register Mapping.</b> These bits determine the DC register visibility within the standard VGA memory space (A0000h-BFFFFh). Note that the VGA address space control bits override this feature. If the Miscellaneous Output register RAM Enable bit is 0, all VGA memory space is disabled. Or, if the Memory Map bits of the Graphics Miscellaneous register are set the same as these bits, then the VGA frame buffer memory will appear in this space instead of the GUI registers.  00: Disabled 01: A0000h 10: B0000h 11: B8000h
0	PACK_CH4	<b>Packed Chain4:</b> When this bit is set, the chain4 memory mapping will not skip DWORDs as in true VGA. Host reads and writes to frame buffer DWORDs are contiguous. When this bit is 0, host accesses behave normally and access 1 DWORD out of every 4. Note that this bit has no effect on the VGA display refresh activity. This bit is only intended to provide a front end for packed SVGA modes being displayed by DC.

**6.6.23.3 ExtendedStartAddress**

CRTC Index 044h  
 Type R/W  
 Reset Value 00h

**ExtendedStartAddress Register Bit Descriptions**

Bit	Name	Description
7:6	RSVD	<b>Reserved.</b>
5:0	ST_AD_RG [21:16]	<b>Start Address Register Bits [21:16].</b> Start Address Register Bits [23:18]: These bits extend the VGA start address to 24 bits. Bits [17:10] are in Start Address Hi (Index 0Ch), and bits [9:2] are in Start Address Lo (Index 0Ch).

**6.6.23.4 WriteMemoryAperture**

CRTC Index 047h  
 Type R/W  
 Reset Value 00h

**WriteMemoryAperture Register Bit Descriptions**

Bit	Name	Description
7:0	WR_BASE	<b>WriteBase.</b> Offset added to the graphics memory base to specify where VGA write operations start. This value provides DWORD address bits [21:14] when mapping host VGA writes to graphics memory. This allows the VGA base address to start on any 64 KB boundary within the 8 MB of graphics memory.

**6.6.23.5 ReadMemoryAperture**

CRTC Index 048h  
 Type R/W  
 Reset Value 00h

**ReadMemoryAperture Register Bit Descriptions**

Bit	Name	Description
7:0	RD_BASE	<b>ReadBase.</b> Offset added to the graphics memory base to specify where VGA read operations start. This value provides DWORD address bits [21:14] when mapping host VGA reads to graphics memory. This allows the VGA base address to start on any 64 KB boundary within the 8 MB of graphics memory.

**6.6.23.6 BlinkCounterCtl**

CRTC Index 060h  
 Type R/W  
 Reset Value 00h

This register is for simulation and test only.

**BlinkCounterCtl Register Bit Descriptions**

Bit	Name	Description
7	HLD_CNT	<b>Hold Count.</b> When set, prevents the blink counter from incrementing with each leading edge VSYNC.
6:5	RSVD	<b>Reserved.</b>
4:0	BLNK_CNT	<b>Blink Count.</b> The blink counter is loaded with this value while the Sequencer Reset register is in the reset state.

**6.6.23.7 BlinkCounter**

CRTC Index 061h  
 Type RO  
 Reset Value 00h

This register is for simulation and test only.

**BlinkCounter Register Bit Descriptions**

Bit	Name	Description
7:5	RSVD	<b>Reserved.</b>
4:0	BLNK_CNT	<b>Blink Count.</b> These bits provide a real-time blink counter value. This register is not synchronized to the system clock domain.

**6.6.23.8 VGALatchSavRes**

CRTC Index 070h  
 Type R/W  
 Reset Value 00h

**VGALatchSavRes Register Bit Descriptions**

Bit	Name	Description
7:0	VGA_LSR	<b>VGALatchSavRes.</b> This register is used to save/restore the 32-bit VGA data latch. When the CRTC index register is written, an internal byte counter is cleared to 0. Four successive reads or writes to the CRTC data register at this index will return or write bytes 0 (bits [7:0]), 1 (bits [15:8]), 2 (bits [23:16]), then 3 (bits [31:24]) in sequence.

**6.6.23.9 DACIFSavRes**

CRTC Index 071h  
 Type R/W  
 Reset Value 00h

**DACIFSavRes Register Bit Descriptions**

Bit	Name	Description
7:0	DACIFSR	<b>DACIFSavRes.</b> This register is used to save/restore the VGA palette interface logic state. When the CRTC index register is written, an internal byte counter is cleared to 0. Four successive reads or writes to the CRTC data register at this index will return or write bytes 0 (bits [7:0]), 1 (bits [15:8]), 2 (bits [23:16]), then 3 (bits [31:24]) in sequence.

## 6.7 Video Processor

The Video Processor (VP) module provides a high-performance, low-power CRT/TFT display or video output interface. There are three main functions contained within the VP: the Video Processor, the TFT controller, and the video output port (VOP). The scaling, filtering, and color space conversion algorithms implemented in the VP are of much higher quality than those used in software-only video playback systems. The VP is capable of delivering high-resolution and true-color graphics. It can also overlay or blend a scaled true-color video image on the graphic background. For video input, integrated scaling, and X and Y interpolation, enable real-time motion video output. The video path of the VP also contains horizontal and vertical scaling hardware, and an optional YUV-to-RGB color space converter. This motion video acceleration circuitry is integrated into the Video Processor to improve video playback. By off-loading these arithmetic-intensive tasks from the processor, 30 frame-per-second playback can be easily achieved, while keeping processor utilization to acceptable performance levels. The graphics and video path is illustrated in Figure 6-23 on page 389.

### General Features

- Hardware video acceleration
- Graphics/video overlay and blending
- Progressive video from the Display Controller module
- Dot Clocks up to 350 MHz

### Hardware Video Acceleration

- Arbitrary X and Y interpolation using three line-buffers
- YUV-to-RGB color space conversion
- Horizontal filtering and downscaling
- Supports 4:2:2 and 4:2:0 YUV formats and RGB 5:6:5 format

### Graphics-Video Overlay and Blending

- Overlay of true-color video up to 24-bpp
- Supports chroma key and color key for both graphics and video streams
- Supports alpha-blending with up to three alpha windows that can overlap one another
- 8-bit alpha values with automatic increment or decrement on each frame
- Optional gamma correction for video or graphics

### Compatibility

- Supports Microsoft's Direct Draw/Direct Video and DCI (Display Controller Interface) v2.0 for full motion video playback acceleration
- Compatible with VESA, VGA, and DPMS standards for enhanced display control and power management

### 6.7.1 Architecture Overview

The Video Processor module contains the following functional blocks. (Figure 6-23 on page 389 shows the relationships between these blocks):

- Video Data Interface
  - Video Formatter
  - Downscaler
  - 5 Line Buffers
  - Vertical Upscaler (Programmable up to x8)
  - Horizontal Upscaler (Programmable up to x8)
- Control Registers
- Mixer/Blender
  - Color Space Converter (CSC)
  - Gamma RAM
  - Color Keys
  - Alpha Blender
- CRT DACs
- TFT Interface
- Video Output Port

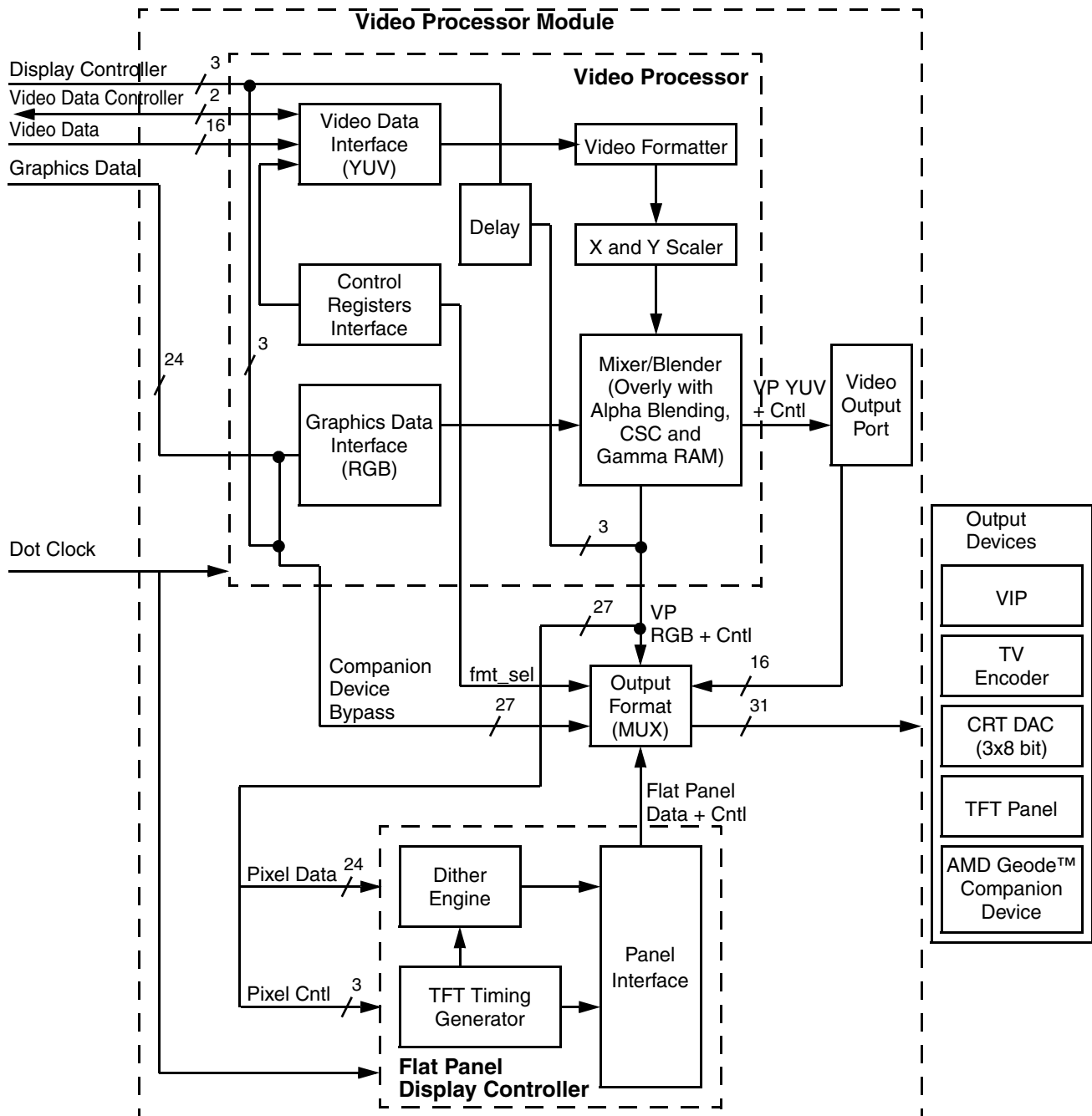


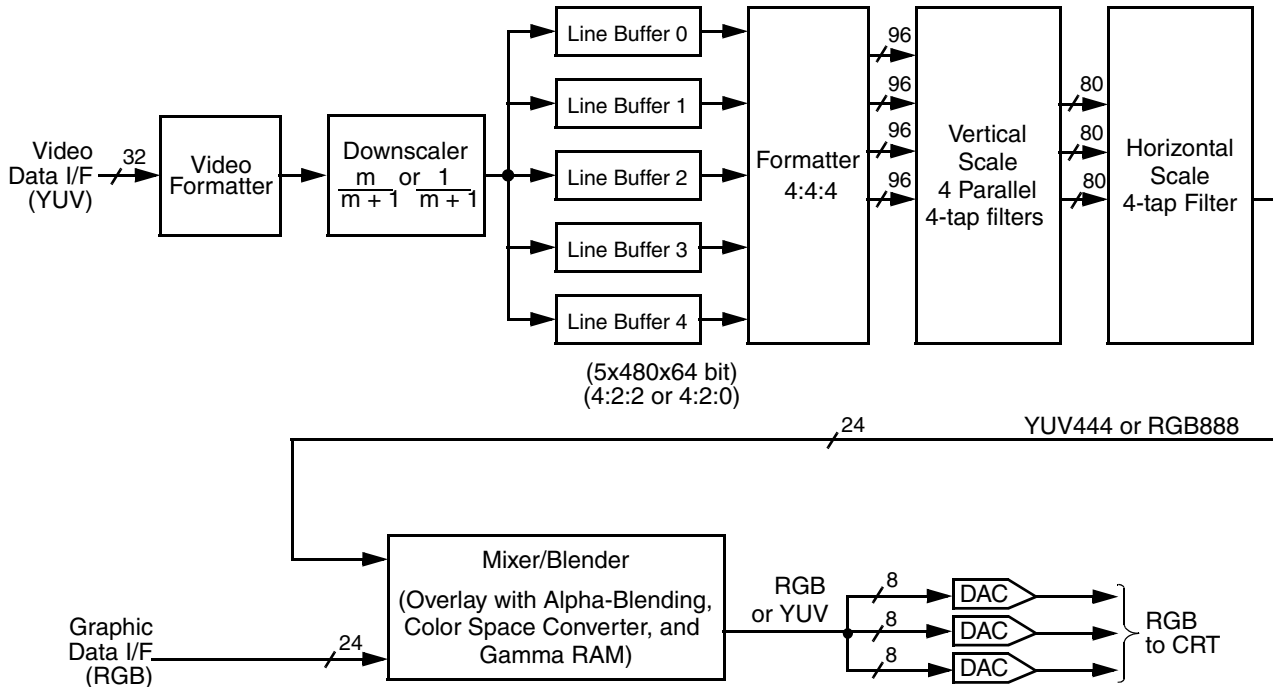
Figure 6-23. Video Processor Block Diagram

**6.7.2 Functional Description**

The VP receives the input video stream in either YUV (4:2:2 or 4:2:0) or RGB (5:6:5) format. The VP has an integrated color space converter to convert YUV data to RGB data. The video clock must always be active (regardless of the source of video input).

Either graphics, or graphics and video mixed (via color-keying or alpha-blending) can be displayed. Mixing can be performed in either the RGB or YUV domain.

For video input, integrated scaling and X and Y interpolation enable real-time motion video output. The video path of the VP also contains horizontal and vertical scaling hardware, and an optional YUV-to-RGB color space converter. This motion video acceleration circuitry is integrated into the VP to improve video playback. By off-loading these arithmetic-intensive tasks from the CPU, 30 frame-per-second playback can be easily achieved, while keeping CPU utilization to acceptable performance levels.



**Figure 6-24. Video Processor Block Diagram**

### 6.7.2.1 Video Formatter

The Video Processor module accepts video data at a rate asynchronous to the GLIU clock rate. The byte order of video input data can be configured using the VID\_FMT bits in the Video Configuration register (VP Memory Offset 000h[3:2]).

Video input data can be in YUV 4:2:2, YUV 4:2:0, or RGB 5:6:5 format. The video input data is packed into a 32-bit WORD and written to one of three on-chip line buffers to significantly reduce video bandwidth. Each line buffer is 480x64 bits, and supports up to a maximum of 1920 horizontal source video pixels.

#### YUV Video Formats

Two different input data formats can be used by the video formatter for overlay of video or graphics data:

##### 1) 4:2:2 Video Format

Four different types of 4:2:2 formats may be used. See the VID\_FMT bits in the Video Configuration register (VP Memory Offset 000h[3:2]) for details about these formats. Ensure that the selected format is appropriate for the data source.

##### 2) 4:2:0 Video Format

This format contains all Y data for each line followed by all U data and all V data. For example, for a line with 720 pixels, 720 bytes of Y data is followed by 360 bytes of U data and 360 bytes of V data for that line. This format is usually used for input from the processor video buffer (i.e., generated by application software).

This format is selected when the EN\_420 bit (VP Memory Offset 000h[28]) is set to 1. The following possible subformat types (described for four bytes of data) can be selected via the VID\_FMT bits (VP Memory Offset 000h[3:2]):

```
00: Y0 Y1 Y2 Y3
01: Y3 Y2 Y1 Y0
10: Y1 Y0 Y3 Y2
11: Y1 Y2 Y3 Y0
```

**Note:** The above formats describe Y data. U and V data have the same format (where “U” and “V” replace the “Y” in this sample).

#### RGB Video Format

In this format, each pixel is described by 16 bits:

```
Bits [15:11]: Red
Bits [10:5]: Green
Bits [4:0]: Blue
```

This format can be used for a second graphics plane if video mixing is not used.

Four subformats can be selected via the VID\_FMT bits (VP Memory Offset 000h[3:2]):

```
00: P1L P1M P2L P2M
01: P2M P2L P1M P1L
10: P1M P1L P2M P2L
11: P1M P2L P2M P1L
```

#### Notes:

- 1) P1M is the most significant byte (MSB) of pixel 1.
- 2) P1L is the least significant byte (LSB) of pixel 1.
- 3) P2M is the MSB of pixel 2.
- 4) P2L is the LSB of pixel 2.
- 5) Within each pixel (2 bytes) RGB ordering is constant.
- 6) This mode does not work if EN\_420 is high (VP Memory Offset 000h[28] = 1).

### 6.7.2.2 4x4 Filter/Scaler

- Accepts all SD and HD television resolutions as well as non-standard video window sizes.
- Horizontal arbitrary scaling:
  - Up to 1:8 upscale.
  - Down to 8:1 downscale.
- Vertical arbitrary scaling:
  - Up to 1:8 upscale.
  - Down to 2:1 downscale.
- 16-pixel filtering:
  - One horizontal 4-tap filter.
  - Four parallel vertical 4-tap filters.
  - 128 or 256 phase in both horizontal and vertical directions.
  - Programmable 16-bit signed horizontal and vertical coefficients.
- Five video line buffers:
  - Four active line buffers.
  - One extra line buffer for buffer elasticity and downscale.
- Line buffer interface operates at GLIU clock up to 400 MHz.
- Horizontal and vertical filter/scaler operates at Dot clock up to 350 MHz

The VP 4x4 filter/scaler contains multiple 4-tap filters that are used in conjunction with an upscale/downscale processing section. There are five video line buffers that store YUV pixels for upcoming display lines.

### 6.7.2.3 Horizontal Downscaling

The Video Processor module supports horizontal downscaling (see Figure 6-25). The downscaler can be implemented in the Video Processor module to shrink the video window by a factor of up to 8:1, in one-pixel increments. The Downscaler Factor Select ( $m$ ) is programmed in the Video Downscaler Control register (VP Memory Offset 078h[4:1]). If bit 0 (DCF) of this register is set to 0, the downscaler logic is bypassed.

**Note:** Horizontal downscaling is supported in 4:2:2 YUV video format only, not 4:2:0 YUV or 5:6:5 RGB.

The downscaler supports up to 29 downscaler factors. There are two types of factors:

- Type A is  $(1/m+1)$ . One pixel is retained, and  $m$  pixels are dropped. This enables downscaling factors of 1/8, 1/7, 1/6, 1/5, 1/4, 1/3, and 1/2.
- Type B is  $(m/m+1)$ .  $m$  pixels are retained, and one pixel is dropped. This enables downscaling factors of 2/3, 3/4, 4/5, 5/6, 6/7, 7/8.

Bit 6 of the Video Downscaler Control register (VP Memory Offset 078h) selects the type of downscaling factor to be used.

**Note:** There is no vertical downscaling in the Video Processor module.

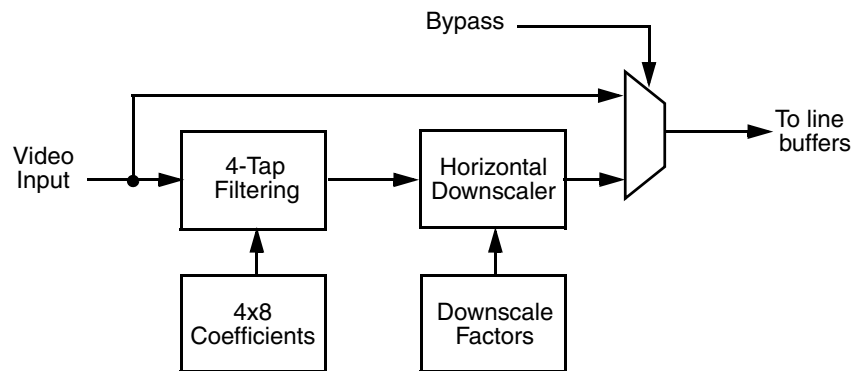


Figure 6-25. Downscaler Block Diagram



### 6.7.3 X and Y Upscaler

After the video data has been buffered, the upscaling algorithm is applied. The Video Processor module employs a Digital Differential Analyzer-style (DDA) algorithm for both horizontal and vertical upscaling. The scaling parameters are programmed via the Video Scale register (VP Memory Offset 020h). The scalars support up to 8x scale factors both horizontally and vertically. The scaled video pixel stream is then passed through bi-linear interpolating filters (2-tap, 8-phase) to smooth the output video, significantly enhancing the quality of the displayed image.

The X and Y Upscaler uses the DDA and linear interpolating filter to calculate (via interpolation) the values of the pixels to be generated. The interpolation formula uses  $A_{i,j}$ ,  $A_{i,j+1}$ ,  $A_{i+1,j}$ , and  $A_{i+1,j+1}$  values to calculate the value of intermediate points. The actual location of calculated points is determined by the DDA algorithm.

The location of each intermediate point is one of eight phases between the original pixels (see Figure 6-26).

### 6.7.4 Color Space Converter

After scaling and filtering have been performed, YUV video data is passed through the color space converter to obtain 24-bit RGB video data.

Color space conversion equations are based on the BT.601-1 recommendation:

Standard definition color space conversion equations are based on Microsoft's recommendations as follows:

$$R = 1.164383(Y-16) + 1.596027(V-128)$$

$$G = 1.164383(Y-16) - 0.812968(V-128) - 0.391762(U-128)$$

$$B = 1.164383(Y-16) + 2.017232(U-128)$$

For high definition video, the color space conversion equations are based on Rec. ITU-R BT.709 as follows:

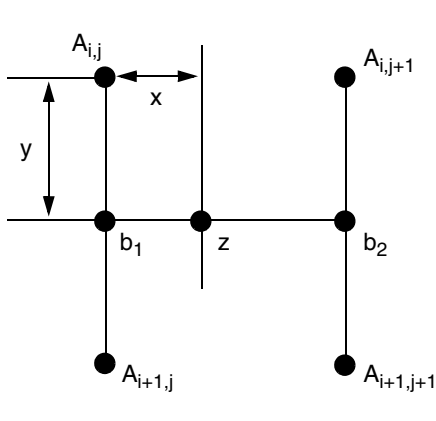
$$R = 1.164383(Y-16) + 1.792742(V-128)$$

$$G = 1.164383(Y-16) - 0.532909(V-128) - 0.213249(U-128)$$

$$B = 1.164383(Y-16) + 2.112402(U-128)$$

The color space converter clamps inputs to prevent them from exceeding acceptable limits.

The color space converter can be bypassed for overlaying 16-bpp graphics data.



#### Notes:

x and y are 0 - 7

$$b_1 = (A_{i,j}) \frac{8-y}{8} + (A_{i,j+1}) \frac{y}{8}$$

$$b_2 = (A_{i,j+1}) \frac{8-y}{8} + (A_{i+1,j+1}) \frac{y}{8}$$

$$z = (b_1) \frac{8-x}{8} + (b_2) \frac{x}{8}$$

Figure 6-26. Linear Interpolation Calculation

### 6.7.5 Video Overlay

Video data is mixed with graphics data according to the video window position. The video window position is programmable via the Video X Position (VP Memory Offset 010h) and Video Y Position (VP Memory Offset 018h) registers. A color-keying and alpha-blending mechanism is employed to compare either the source (video) or destination (graphics) color to the color key programmed via the Video Color Key register (VP Memory Offset 028h), and to select the appropriate bits in the Video Color Mask register (VP Memory Offset 030h). This mechanism greatly reduces the software overhead for computing visible pixels, and ensures that the video display window can be partially hidden by overlapping graphics data. See Figure 6-27 on page 395.

The Video Processor module accepts graphics data at the graphics Dot clock rate. The Video Processor module can display graphics resolutions up to 1920x1440 on CRT, at color depths up to 24-bpp while simultaneously overlaying a video window.

#### 6.7.5.1 Alpha-Blending

Alpha-blending can be performed using RGB blending or YUV blending:

- For RGB blending, graphic data in RGB format and video data in RGB format (YUV to RGB conversion) are blended.
- YUV blending eliminates video de-interlacing and YUV to RGB conversion of video data. For YUV blending, the graphic data is converted to YUV and blended with video in YUV format.

Up to three alpha windows can be defined in the video window. Alpha values for blending are defined for each pixel in the upper 8 bits of video data. If alpha windows overlap, the alpha window with the highest priority (programmable) is used (for the overlapped area).

Alpha-blending is performed using the following formula:

$$\text{alpha} * G + (1 - \text{alpha}) * V$$

Where G is the graphic value and V is the video value of the current pixel.

### Color Keys

A color key mechanism is used with alpha-blending. Color key values are defined for a cursor color key and for a normal color key. The cursor color key is compared to each 24-bit value of graphic input data. If a match is found, the selected cursor color is displayed. Two possible cursor colors can be defined. The COLOR\_REG\_OFFSET field (in the Cursor Color Key register, VP Memory Offset 0A0h[28:24]) is used to select the bit in the input graphic stream that determines the cursor color to use. Each cursor color is stored in a separate cursor color register. Figure 6-28 on page 396 illustrates the logic used to determine how to implement the color key and alpha-blending logic.

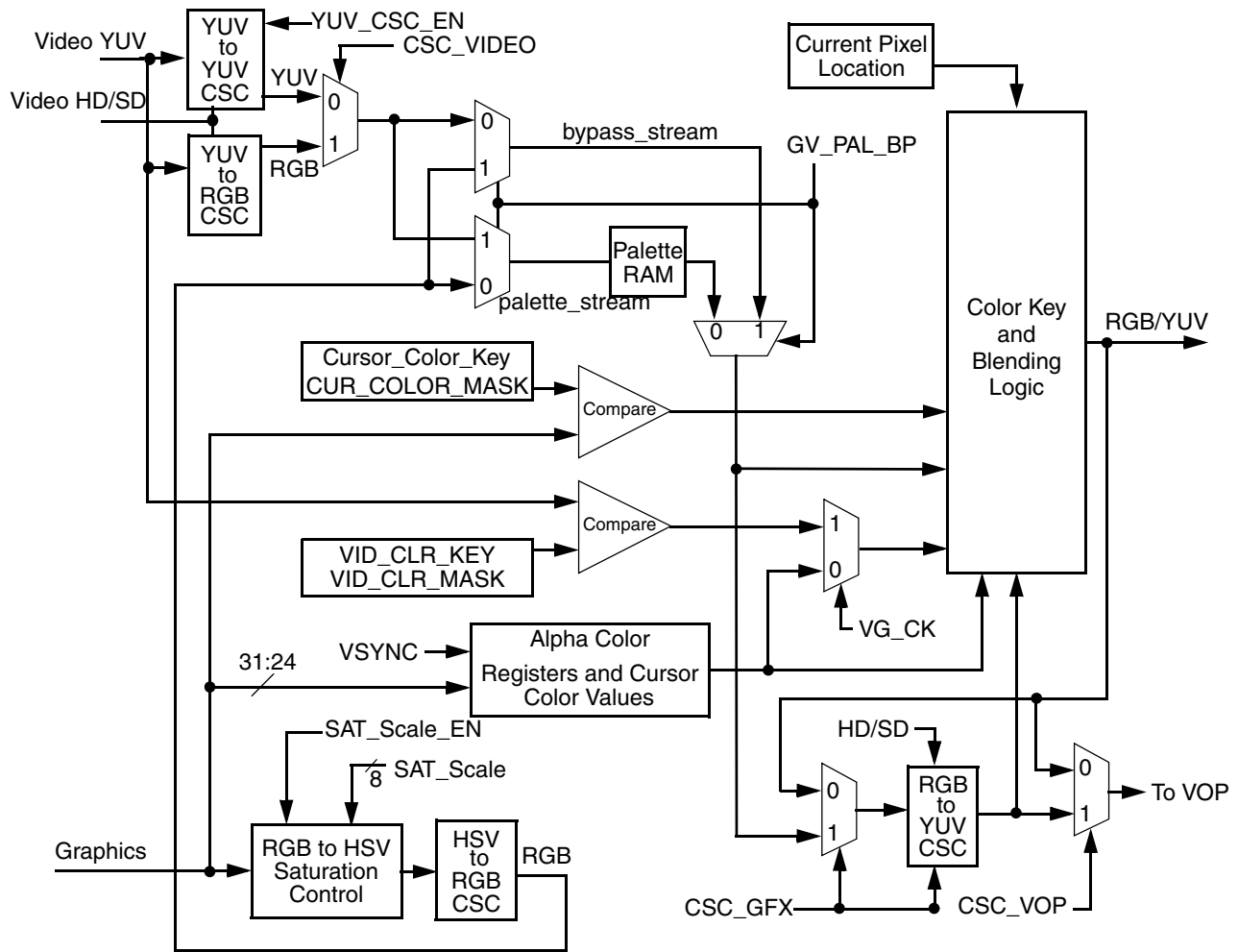
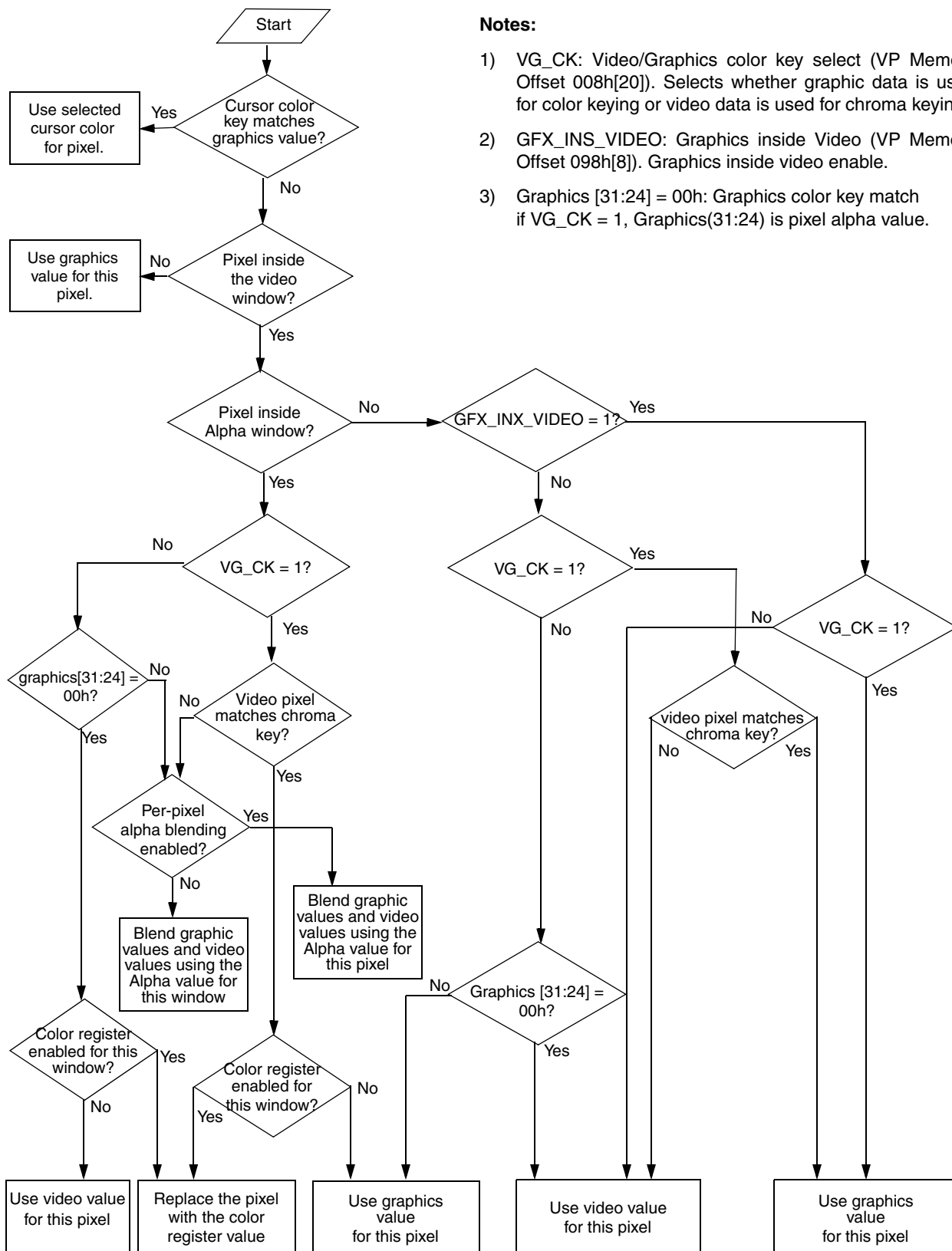


Figure 6-27. Mixer Block Diagram



**Notes:**

- 1) VG\_CK: Video/Graphics color key select (VP Memory Offset 008h[20]). Selects whether graphic data is used for color keying or video data is used for chroma keying.
- 2) GFX\_INS\_VIDEO: Graphics inside Video (VP Memory Offset 098h[8]). Graphics inside video enable.
- 3) Graphics [31:24] = 00h: Graphics color key match if VG\_CK = 1, Graphics(31:24) is pixel alpha value.

**Figure 6-28. Color Key and Alpha-Blending Logic**

Table 6-60 represents the same logic that is displayed in Figure 6-28 on page 396.

**Table 6-60. Truth Table for Alpha-Blending**

VG_CK (Note 1)	Windows	Configuration (Note 2)	Graphics Data Match Cursor Color Key	Graphics [31:24] = 00h	Per-pixel Alpha Blending Enabled	Video Data Match Normal Color Key	Mixer Output
x (Note 3)	x	x	Yes	x	x	x	Cursor color
x	Not in Video Window	x	No	x	x	x	Graphic data
Graphics Color Key (VG_CK = 0)	Not in Alpha Window	GFX_INS_VIDEO = 0	No	Yes	x	x	Video data
			No	No	x	x	Graphic data
		GFX_INS_VIDEO = 1	No	x	x	x	Video data
	Inside Alpha Window x	ALPHAx_COLOR_REG_EN = 1	No	Yes	x	x	Color from color register
		ALPHAx_COLOR_REG_EN = 0	No	Yes	x	x	Video data
		x	No	No	No	x	Window alpha- blended data
x		No	No	Yes	x	Per-pixel alpha- blended data	
Video Chroma Key (VG_CK = 1)	Not in Alpha Window	GFX_INS_VIDEO = 0	No	x	x	Yes	Graphic data
			No	x	x	No	Video data
		GFX_INS_VIDEO = 1	No	x	x	x	Graphic data
	Inside Alpha Window x	ALPHAx_COLOR_REG_EN = 1	No	x	x	Yes	Color from color register
		ALPHAx_COLOR_REG_EN = 0	No	x	x	Yes	Graphic data
		x	No	x	Yes	No	Per-pixel alpha- blended data
x		No	x	No	No	Window alpha- blended data	

Note 1. VG\_CK is bit 20 in the Display Configuration register (VP Memory Offset 0008h).

Note 2. GFX\_INS\_VIDEO is bit 8 in the Video De-interlacing and Alpha Control register (VP Memory Offset 0098h).

ALPHAx\_COLOR\_REG\_EN are bit 24 in the Alpha Window Color registers (VP Memory Offsets 0D0h, 0F0h, and 110h).

Note 3. x = Don't care.

### 6.7.5.2 Gamma RAM

Either the graphics or video stream can be routed through an integrated palette RAM for gamma-correction of the data stream or (for video data) contrast/brightness adjustments.

A bypass path is provided for either the graphics or video stream (depending on which is sent through the gamma RAM).

### 6.7.5.3 Video Processor Module Display Interface

The Video Processor module connects directly to either the internal CRT DACs, or provides a standard digital TFT interface.

### 6.7.5.4 Video Interface

The VP uses a two-wire protocol to control the sequence of data on the video port. This protocol consists of VID\_VAL and VID\_RDY. VID\_VAL indicates the DC has placed valid data on the 32-bit VID\_DATA bus. VID\_RDY indicates the VP is ready to accept video data for the next video source line. The VP typically starts fetching video data five scan lines before the data is required for display.

## 6.7.6 Video Output Port

### 6.7.6.1 Functional Overview

The Video Output Port (VOP) receives YUV 4:4:4 encoded data from the VP and formats the data into a video-stream that is BT.656 or BT.601 compliant. Output from the VOP goes to either a VIP or a TV encoder. The VOP must be BT.656/BT.601 compliant since its output may go directly (or indirectly) to a display.

### 6.7.6.2 Supported Features

- VIP 2.0 (level I and II) with VIP 1.1 compatibility mode, BT.656 mode supported
- Support for VIP 2.0 NON\_INT bit (REPEAT and EXT\_FLAG not supported)
- BT.601 mode supported
- VBI data supported (no support for ancillary data)

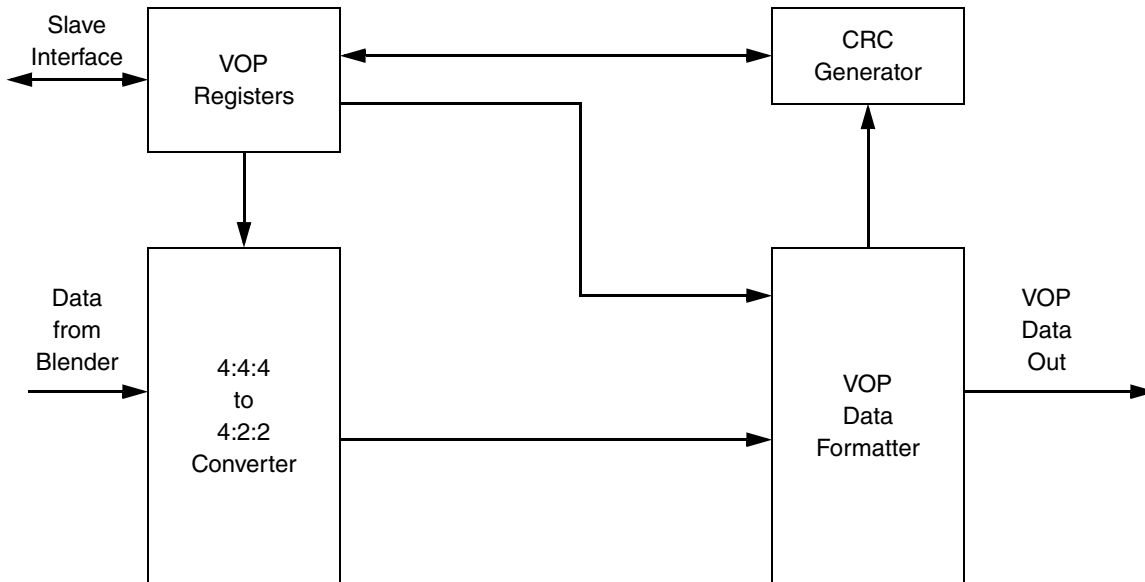


Figure 6-29. VOP Internal Block Diagram

### 6.7.6.3 HBLANK and VBLANK Signals

HBLANK and VBLANK signals are different from HSYNC and VSYNC. The HSYNC and VSYNC signals are only active for a portion of the blanking time, while the HBLANK and VBLANK signals are active through the entire time. HBLANK is a function of horizontal pixel position, while

VBLANK is a function of the vertical line number and the horizontal pixel position. Figures 6-30 to 6-34 show the formation of these signals using a 525-line NTSC video window.

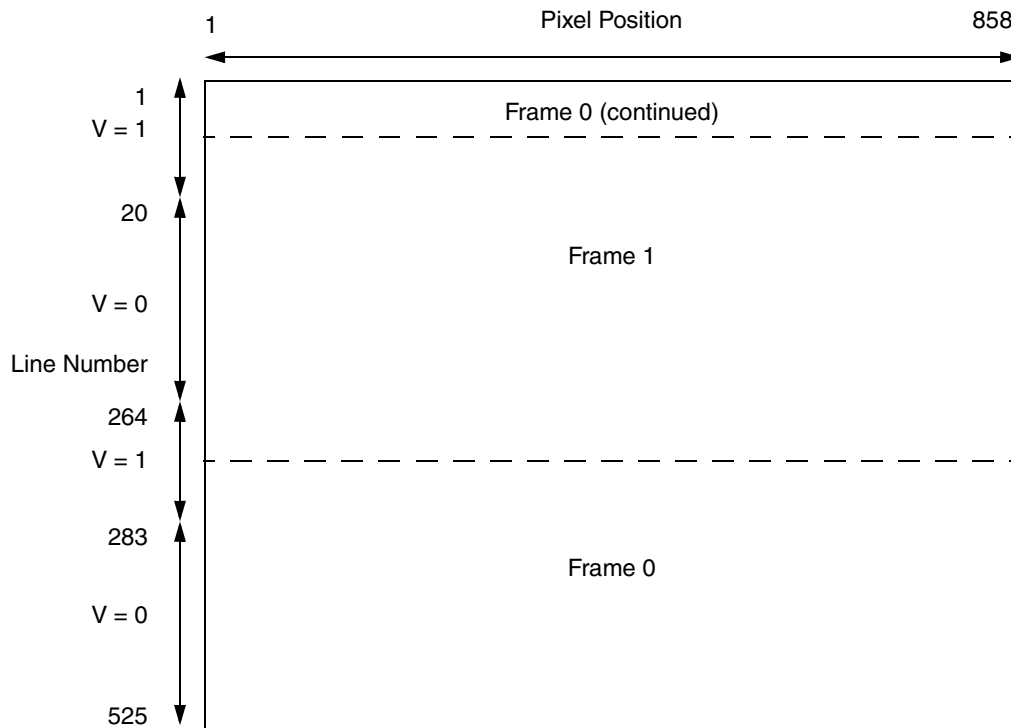


Figure 6-30. 525-Line NTSC Video Window

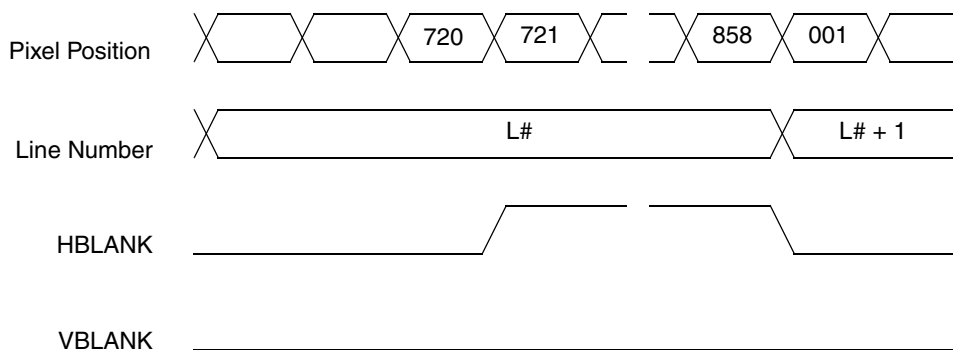
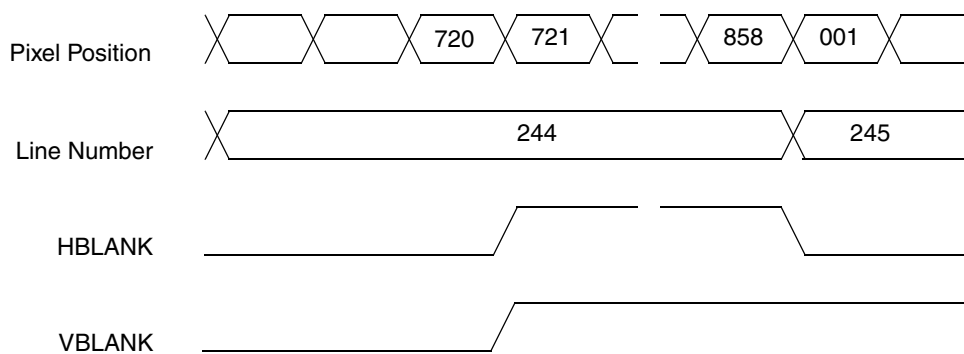
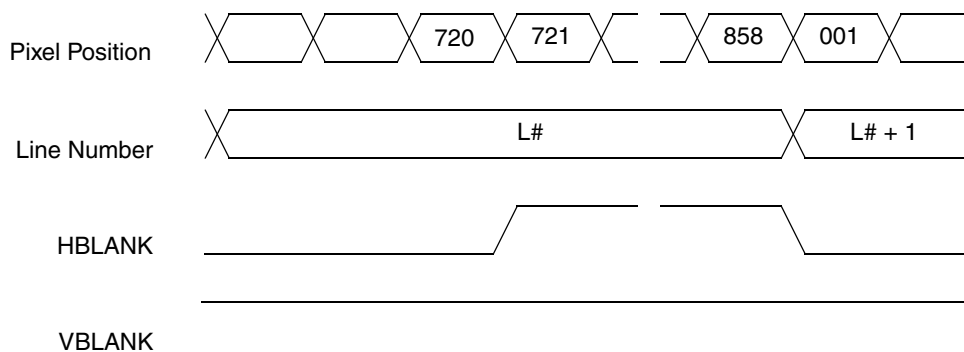


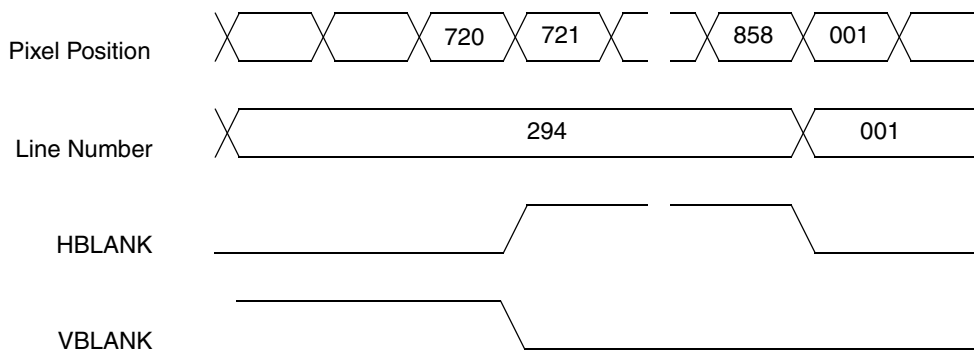
Figure 6-31. HBLANK and VBLANK for Lines 20-262, 283-524



**Figure 6-32. HBLANK and VBLANK for Lines 263, 525**



**Figure 6-33. HBLANK and VBLANK for Lines 1-18, 264-281**



**Figure 6-34. HBLANK and VBLANK for Lines 19, 282**



**6.7.6.4 Interface to Video Processor**

The output from the Video Processor is connected via a 24-bit bus. Bytes on this bus are aligned as shown below:

[23:16] Y  
 [15:8] Cr (V)  
 [7:0] Cb (U)

The VOP takes this 24-bit 4:4:4 data bus and converts it to a 16-bit 4:2:2 data bus (the Y component on the high byte, the U/V components alternating on the low byte).

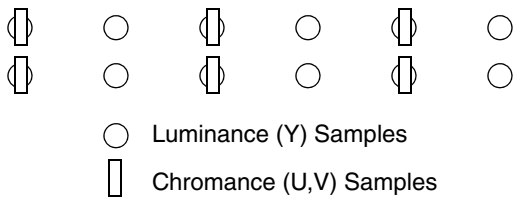
The VOP provides three different methods for translating from 4:4:4 to 4:2:2 data depending on the value of the mode select bits from the VOP Configuration register (VP Memory Offset 800h[5:4]) as shown in Table 6-61.

**Table 6-61. VOP Mode**

Mode	Bits	Description
0	00	4:2:2 Co-sited (Recommended)
1	01	4:2:2 Interspersed
2	10	4:2:2 Interspersed, free-running

**Mode 0: 4:2:2 Co-sited**

In this mode, the U/V samples are dropped on alternating sample sets, resulting in the below representation.



Sampling algorithm:

Y, U, V : 4:4:4 Input data

Y', U', V' : 4:2:2 Sampled data

$$Y1' = Y1, U1' = U1, V1' = V1$$

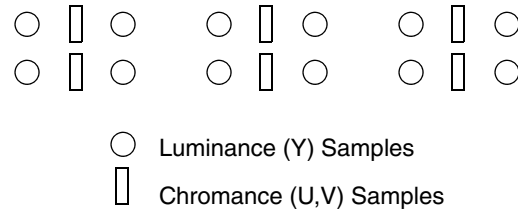
$$Y2' = Y2$$

$$Y3' = Y3, U3' = U3, V3' = V3$$

etc.

**Mode 1: 4:2:2 Interspersed**

In this mode, adjacent pairs of U/V sample data are averaged, with the U/V samples coming from the same adjacent sample sets.



Sampling algorithm:

Y, U, V : 4:4:4 Input data

Y', U', V' : 4:2:2 Sampled data

$$Y1' = Y1, U1' = (U1+U2)/2, V1' = (V1+V2)/2$$

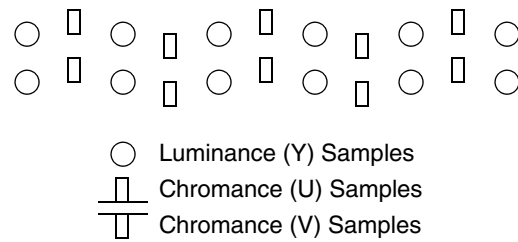
$$Y2' = Y2$$

$$Y3' = Y3, U3' = (U3+U4)/2, V3' = (V3+V4)/2$$

etc.

**Mode 2: 4:2:2 Interspersed (free-running)**

This mode is the same as Mode 1 with the exception that the U sample is averaged between the first two samples, and the V sample is averaged between the second and third samples.



Sampling algorithm:

Y, U, V : 4:4:4 Input data

Y', U', V' : 4:2:2 Sampled data

$$Y1' = Y1, U1' = (U1+U2)/2$$

$$Y2' = Y2, V2' = (V2+V3)/2$$

$$Y3' = Y3, U3' = (U3+U4)/2$$

$$Y4' = Y4, V3' = (V4+V5)/2$$

etc.

### 6.7.6.5 Operating Modes

#### BT.656 Mode

BT.656 is the basic standard that specifies the encoding of the control lines into the data bus. In this mode the separate control lines are encoded into the data bus as specified by Recommendation ITU-R BT.656.

Each line begins with a Start of Active Video (SAV) header, and ends with an End of Active Video (EAV) header. Each of these are four-byte sequences beginning with FF, 00, 00. The fourth byte of the header provides important information about this line. The bit format of the SAV and EAV headers is shown in Table 6-62.

**Table 6-62. SAV/EAV Sequence**

Parameter	D7	D6	D5	D4	D3	D2	D1	D0
Preamble	1	1	1	1	1	1	1	1
	0	0	0	0	0	0	0	0
	0	0	0	0	0	0	0	0
Status Word	T	F	V	H	P3	P2	P1	P0

The T bit is specified in BT.656 as a constant logic 1. The F bit indicates Field - 1 for even (also called Field 2), 0 for odd (Field 1). The V bit indicates Vertical Blanking. The H bit indicates Horizontal Blanking. Bits P3 through P0 are protection bits used to detect and correct single-bit errors. The bits are defined as follows:

$$P3 = (V + H) + \sim T$$

$$P2 = (F + H) + \sim T$$

$$P1 = (F + V) + \sim T$$

$$P0 = (F + V) + H$$

Using the above formulas, the bit values are listed in Table 6-63.

**Table 6-63. Protection Bit Values**

T	F	V	H	P3	P2	P1	P0	Hex
0	0	0	0	1	1	1	0	0E
0	0	0	1	0	0	1	1	13
0	0	1	0	0	1	0	1	25
0	0	1	1	1	0	0	0	38
0	1	0	0	1	0	0	1	49
0	1	0	1	0	1	0	0	54
0	1	1	0	0	0	1	0	62
0	1	1	1	1	1	1	1	7F
1	0	0	0	0	0	0	0	80
1	0	0	1	1	1	0	1	9D
1	0	1	0	1	0	1	1	AB
1	0	1	1	0	1	1	0	B6
1	1	0	0	0	1	1	1	C7
1	1	0	1	1	0	1	0	DA
1	1	1	0	1	1	0	0	EC
1	1	1	1	0	0	0	1	F1

#### VIP 1.1 Compatible Mode

VIP 1.1 compatible mode builds on CBT.656 mode with the following changes/additions:

- Video Flags T, F, and V can only be changed in the EAV code. During vertical blanking there must be a minimum of one SAV/EAV scan line in order to convey the updated T, F, and V bits.
- Task bit is used to indicate VBI data within the video stream (T = 0 for VBI Data, T = 1 for active video).
- P3-P0 are ignored.

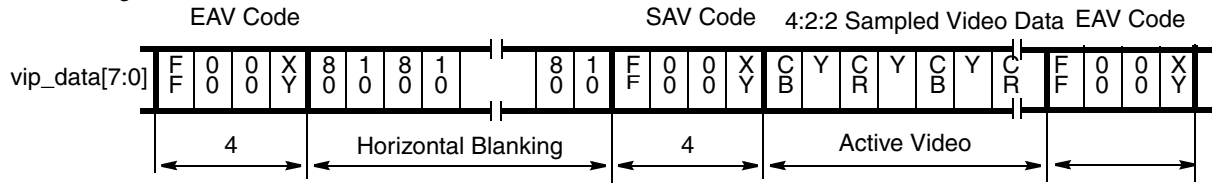
**VIP 2.0 Modes (8 or 16 bits)**

VIP 2.0 mode builds on VIP 1.1 with the following changes/additions:

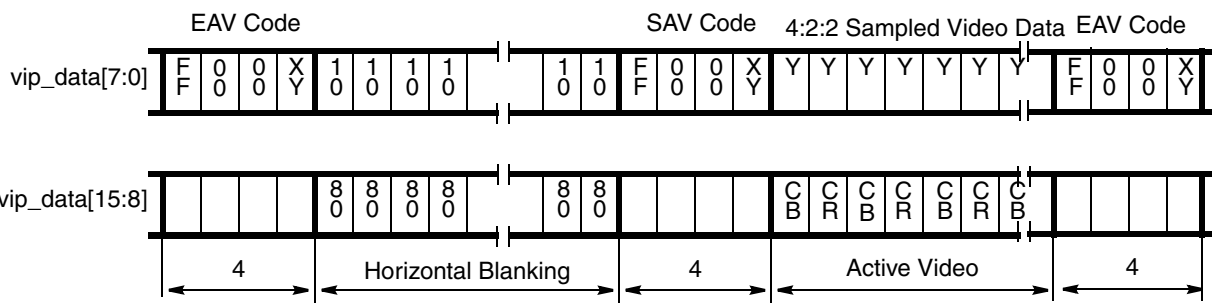
- Video Flags T, F, and V are valid in the EAV and SAV code, valid values must appear no later than the SAV of the first scan line of the next active region (see Figure 6-35).
- Task bit differentiates between two video streams. These streams can be interleaved at a line or field rate.

- New Video Flags - The P Nibble is redefined as [NON\_INT, REPEAT, Reserved, EXT\_FLAG].
  - NON\_INT - 1 = non-interlaced source, 0 = interlaced source.
  - REPEAT - 1 = repeat field in 3:2 pull-down, 0 = not a repeat field (tied to 0).
  - EXT\_FLAG - 1 = extra flag byte follows this EAV, 0 = no extra flag byte (this flag is always 0).

Start of Digital Line



**8-Bit VIP Data (VIP 1.1 and VIP 2.0 Level I)**



**16-Bit VIP Data (VIP 2.0 Level II)**

**Figure 6-35. BT.656 8/16 Bit Line Data**

### 6.7.6.6 New VIP 2.0 Video Flags

Four bits are defined (shown in Table 6-64) by the VIP specification that allow the VIP slave to communicate field/frame-specific information to the graphics chip during the video stream output. These flags are embedded in the lower nibble of the SAV or EAV header. These video flags allow the graphics chip to handle Bob and Weave, as well as 3:2 pull-down in hardware. Only bit 3 is implemented in the AMD Geode LX processor.

**Table 6-64. SAV VIP Flags**

Bit	Flag	Description
3	NON_INT	1 indicates that the video is from a non-interlaced source. 0 indicates that the video is from an interlaced source.
2	REPEAT	1 indicates that the current field is a repeat field. This occurs during 3:2 pull-down. This flag enables a VIP master to drop the repeat field in the weave mode. This bit is not supported in the AMD Geode™ LX processor (tied to 0).
1	RSVD	Reserved.
0	EXT_FLAG	0 indicates no extended flags. This bit is not supported in the AMD Geode LX processor (tied to 0).

### 6.7.6.7 BT.601 Support

When VOP is configured for BT.601 mode, the HSYNCs and VSYNCs are used to determine the timing of each data line sent out. The SAV/EAV codes are not used.

### 6.7.6.8 VIP 2.0 Level System

For even field detection, some devices require a shift in VSYNC with respect to HSYNC. This shift is programmed at DC Memory Offset 080h. Also for correct odd/even field shift, VP Memory Offset 800h[6] = 1.

**Table 6-65. VOP Clock Rate**

Level	Video Port	Max. PIXCLK
I	8-bit	75 MHz
II	16-bit	75 MHz

### 6.7.6.9 VBI Data

Vertical Blanking Interval (VBI) data is not part of the active video (i.e., not directly displayed). This data is sent between fields of active video data during vertical blanking. VBI data has many uses: closed captioning, timecodes, teletext, etc. Although there are some specified standards with respect to closed captioning which are generally decoded at the TV, basically, as long as the data is sent and received correctly, there are no restrictions.

Indication of VBI data is configurable for the different modes.

In BT.656 mode, typically the TASK bit in the EAV/SAV header is fixed at 1. In this case, there is no indication of VBI data. If the VBI bit in the VOP Configuration register is set to 1 (VP Memory Offset 800h[11] = 1), then VBI data will be indicated by a TASK bit value of 0 (active video has the value of 1).

In VIP 1.1 mode, by definition the TASK bit in the EAV/SAV header is 0 for VBI data, and 1 for active video. The VBI bit in the VOP Configuration register has no effect in this mode.

In VIP 2.0 mode, the TASK bit value in the EAV/SAV header is configurable by selecting a value for the TASK bit in the VOP Configuration register. If it is desired to have the TASK bit in the EAV/SAV header indicate VBI data, then setting the VBI bit will use the inverse value of the TASK bit in the VOP Configuration register to indicate VBI data (i.e., if TASK = 1, then VBI data is indicated by a TASK bit value of 0 in the EAV/SAV, if TASK = 0, then VBI data is indicated by a TASK bit value of 1 in the EAV/SAV).

## 6.7.7 Flat Panel Display Controller

### 6.7.7.1 FP Functional Overview

The flat panel (FP) display controller converts the digital RGB output of the Video Mixer block to digital output suitable for driving a TFT flat panel LCD.

Features include:

- 24-bit color support for digital pixel input.
- 170 MHz pixel clock operation supports up to 1600x1200 TFT panels.
- Supports most SVGA TFT panels and the VESA FPD1 (Flat Panel Display Interface) Revision 1.0 Specification.
- TFT panel support provided by use of one connector allows a pass-through mode for the digital pixel input.
- 9-, 12-, 18-, and 24-bit 1 pixel per clock TFT support.

- 9+9 or 12+12-bit, and 24-bit 2 pixels per clock TFT panel support.
- Programmable dither, up to 64 levels.

### 6.7.7.2 FP Architecture Overview

The FP display controller contains the following functional blocks, as shown in Figure 6-36:

- Dither Engine
- Control Registers
- TFT Timing Generator
- Panel Interface
- CRC (Cyclical Redundancy Check) Engine

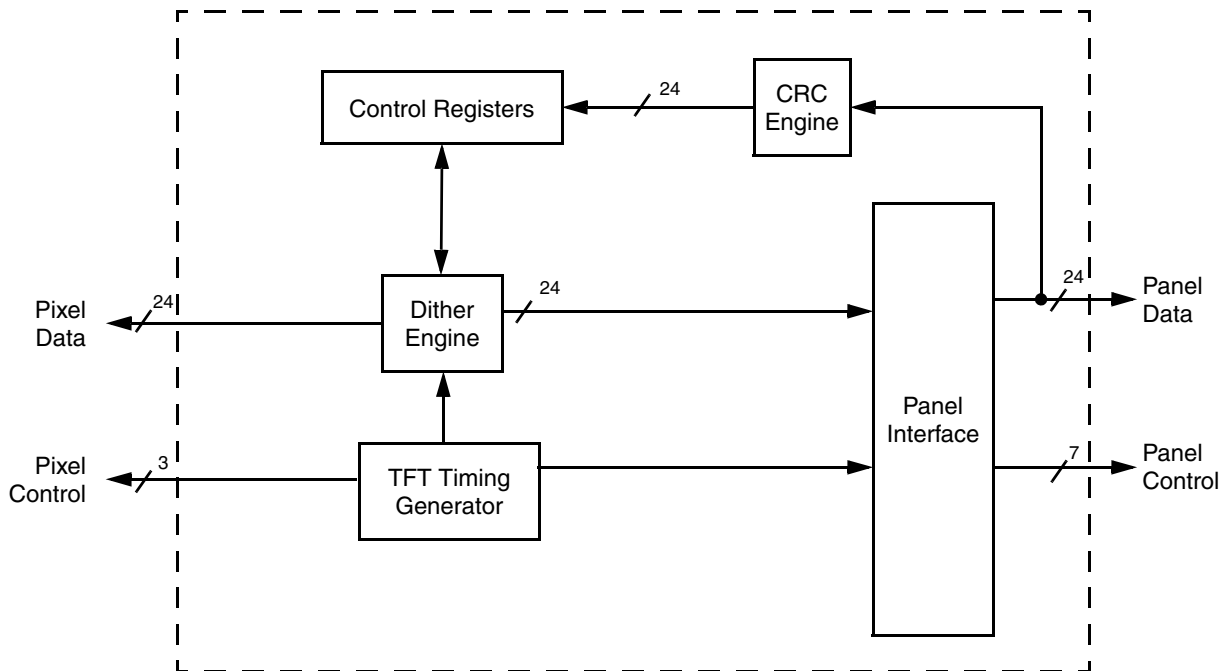


Figure 6-36. Flat Panel Display Controller Block Diagram

### 6.7.7.3 FP Functional Description

The FP connects to the RGB port of the video mixer.

#### LCD Interface

The FP interfaces directly to industry standard 18-bit or 24-bit active matrix thin-film-transistor (TFT). The digital RGB or video data that is supplied by the video logic is converted into a suitable format to drive a wide variety range of panels with variable bits. The LCD interface includes dithering logic to increase the apparent number of colors displayed for use on panels with less than 6 bits per color. The LCD interface also supports automatic power sequence of panel power supplies.

#### Mode Selection

The FP can be configured for operation with most standard TFT panels:

- Supports TFT panels with up to 24-bit interface with 640x480, 800x600, 1024x768, 1280x1024, and 1600x1200 pixel resolutions. Either one or two pixels per clock is supported for all resolutions. Other resolutions below 640x480 are also supported.

Table 6-66 shows the mapping of the data in the supported modes.

For TFT panel support, the output from the dither block is directly fed on to the panel data pins (DRGBx). The data that is being sent on to the panel data pins is in sync with the TFT timing signals such as HSYNC, VSYNC, and LDE. One pixel (or two pixels in 2 pix/clk mode) is shifted on every positive edge of the clock as long as DISP\_ENA is active.

**Table 6-66. Panel Output Signal Mapping**

Pin Name	TFT 9-Bit	TFT 18-Bit	TFT 24-Bit	TFT 9+9-Bit	TFT 12+12-Bit
DRGB0			B0		BB0
DRGB1			B1	BB0	BB1
DRGB2		B0	B2	BB1	BB2
DRGB3		B1	B3	BB2	BB3
DRGB4		B2	B4		GB0
DRGB5	B0	B3	B5	GB0	GB1
DRGB6	B1	B4	B6	GB1	GB2
DRGB7	B2	B5	B7	GB2	GB3
DRGB8			G0		RB0
DRGB9			G1	RB0	RB1
DRGB10		G0	G2	RB1	RB2
DRGB11		G1	G3	RB2	RB3
DRGB12		G2	G4		BA0
DRGB13	G0	G3	G5	BA0	BA1
DRGB14	G1	G4	G6	BA1	BA2
DRGB15	G2	G5	G7	BA2	BA3
DRGB16			R0		GA0
DRGB17			R1	GA0	GA1
DRGB18		R0	R2	GA1	GA2
DRGB19		R1	R3	GA2	GA3
DRGB20		R2	R4		RA0
DRGB21	R0	R3	R5	RA0	RA1
DRGB22	R1	R4	R6	RA1	RA2
DRGB23	R2	R5	R7	RA2	RA3

**Table 6-66. Panel Output Signal Mapping (Continued)**

Pin Name	TFT 9-Bit	TFT 18-Bit	TFT 24-Bit	TFT 9+9-Bit	TFT 12+12-Bit
DOTCLK	CLK	CLK	CLK	CLK	CLK
HSYNC	HSYNC	HSYNC	HSYNC	HSYNC	HSYNC
VSYNC	VSYNC	VSYNC	VSYNC	VSYNC	VSYNC
LDEMOD	LDE	LDE	LDE	LDE	LDE
VDDEN	ENLVDD	ENLVDD	ENLVDD	ENLVDD	ENLVDD

**Maximum Frequency**

The FP will operate at a DOTCLK frequency of up to 170 MHz. There is no minimum frequency; however, many flat panels have signal timings that require minimum frequencies. Refer to the flat panel display manufacturer's specifications as appropriate.

**CRC Signature**

The FP contains hardware/logic that performs Cyclical Redundancy Checks (CRCs) on the digital video/graphics pipeline. This feature is used for error detection and makes it possible to capture a unique 24-or 32-bit signature for any given mode setup. An error in the video/graphics memory interface, control logic, or pixel pipeline will produce a different signature when compared to a known good signature value. This allows the programmer to quickly and accurately test a video screen without having to visually inspect the screen for errors. By default, a 24-bit signature generator is used. For more accuracy, a 32-bit signature generator may be selected.

**Dithering**

After the video mixer gamma RAM logic, the graphic data or the video data goes through the dithering logic.

Some panels have limitations of supporting maximum number of bits to display all color shades that the CRT monitor can support. For example, if the selected mode is 24-bpp and the panel can support only 18-bpp, the remaining two bits for each color is used for dithering to get the desired number of shades as compared to the CRT.

The idea behind dithering is to achieve intermediate color intensities by allowing the human eye to blend or average the intensities of adjacent pixels on a screen. Intensity resolution is gained by sacrificing spatial resolution.

For example, consider just the red color component of a 2x2 square of pixels. If the only two options for the red color component were to be turned on or off, then there would only be two colors, black and the brightest red. However, if two of the pixels' red color components in the 2x2 square were turned on and two were turned off, the human eye would blend these adjacent pixels and the 2x2 pixel square would appear to be half as bright as the brightest red. The drawback is that fine details and boundaries between regions of differing color intensities become slightly blurred.

The FP supports dithering patterns over an 8x8 pixel area. An 8x8 pixel area supports 64 different dithering patterns. This means that the 8-bit input intensity for a given pixel primary color component can be reduced down to its two most significant bits by using the six least significant bits to select a 8x8 pixel pattern whose average intensity is equal to the original 8-bit input intensity value.

As an example, consider a display screen that is capable of producing six different intensities of the red color component for each pixel. Given an 8-bit red intensity value, 01010110, the problem is to come up with a 8x8 pixel pattern, using only the six available red pixel intensities, that when averaged together, yield the value of the original 8-bit intensity.

The values of the six available intensities, padded out to eight bits, are 00000000, 01000000, 01010000, 10000000, 11000000, and 11010000. The given intensity, 010110, lies between 01000000 and 10000000, so these two intensities are used in the 8x8 pixel pattern, as shown in Figure 6-37 on page 408. The average intensity of this 8x8 pattern is 01010110.

The actual dithering pattern is an 8x8 pattern of 1s and 0s. A 0 in a given position of the pattern indicates that the truncated value of the input color component intensity be used. A 1 means use the next higher truncated value. In the previous example, the intensity value was 01010110, the truncated value is 01000000 (least significant six bits set to 0), and the next higher truncated value is 10000000.

The 8x8 dithering pattern for an input intensity value whose least significant six bits are already zero is made up of all 0s. This means that the next higher truncated intensity value is never used because the input intensity value is the same as its truncated value. As the value of the least significant six bits of the input intensity value increases, the input intensity value gets closer to the next higher truncated intensity value, and more 1s are added to the pattern. For example, when the value of the least significant six bits of the input intensity value is 16, there will be sixteen 1s in the dithering pattern and the next higher truncated intensity value will be used sixteen times within the 8x8 pattern.

		X-Count[3:0]							
		000	001	010	011	100	101	110	111
Y-Count[3:0]	000	10000000	01000000	01000000	10000000	01000000	10000000	10000000	01000000
	001	01000000	10000000	01000000	01000000	01000000	10000000	01000000	01000000
	010	01000000	01000000	10000000	01000000	01000000	10000000	10000000	01000000
	011	01000000	01000000	01000000	10000000	01000000	10000000	01000000	10000000
	100	10000000	01000000	01000000	01000000	10000000	10000000	01000000	01000000
	101	01000000	10000000	01000000	01000000	01000000	10000000	01000000	01000000
	110	01000000	01000000	10000000	01000000	01000000	10000000	10000000	01000000
	111	01000000	01000000	01000000	10000000	01000000	10000000	01000000	10000000

**Figure 6-37. Dithered 8x8 Pixel Pattern**

All discussions to this point have referred to a 6-bit dithering scheme. A 6-bit dithering scheme is one in which the least significant six bits of the input intensity value for each pixel color component are truncated and these least significant six bits are used to select an 8x8 dithering pattern.

The FP also supports 4-, 3-, 2-, and 1-bit dithering schemes. In the 4-bit dithering scheme, only the least significant four bits of the input intensity value for each color component are truncated. As the value of the least significant four bits increases from 0 to 15, the order in which 1s are added to the dithering is much the same as in a 6-bit scheme except that two 1s are added to the pattern for each increment of the 4-bit value.

The 3-bit dithering scheme selects a dithering pattern based on the least significant three bits of the input intensity value for each color component. The order in which 1s are added to the dithering pattern as the value of these two bits increases from 0 to 7 is the same as the order for the 6-bit scheme except that two 1s are added to the pattern for each increment of the 3-bit value.

The 2-bit dithering scheme selects a dithering pattern based on the least significant two bits of the input intensity value for each color component. The order in which 1s are added to the dithering pattern as the value of these two bits increases from 0 to 3 is the same as the order for the 6-bit scheme except that four 1s are added to the pattern for each increment of the 2-bit value.

The 1-bit dithering scheme uses the least significant bit of the input intensity value to select one of two dithering patterns. The order that 1s are added to the dithering pattern is the same as the 6-bit scheme except that eight 1s are added to the pattern when the least significant bit is a 1. When the least significant bit is 0, the pattern is all 0s. When the least significant bit is 1, the pattern is alternating 0s and 1s.

Figure 6-38 on page 409 shows the suggested order for adding 1s to the dithering patterns for the 4-, 3-, 2-, and 1-bit dithering schemes.



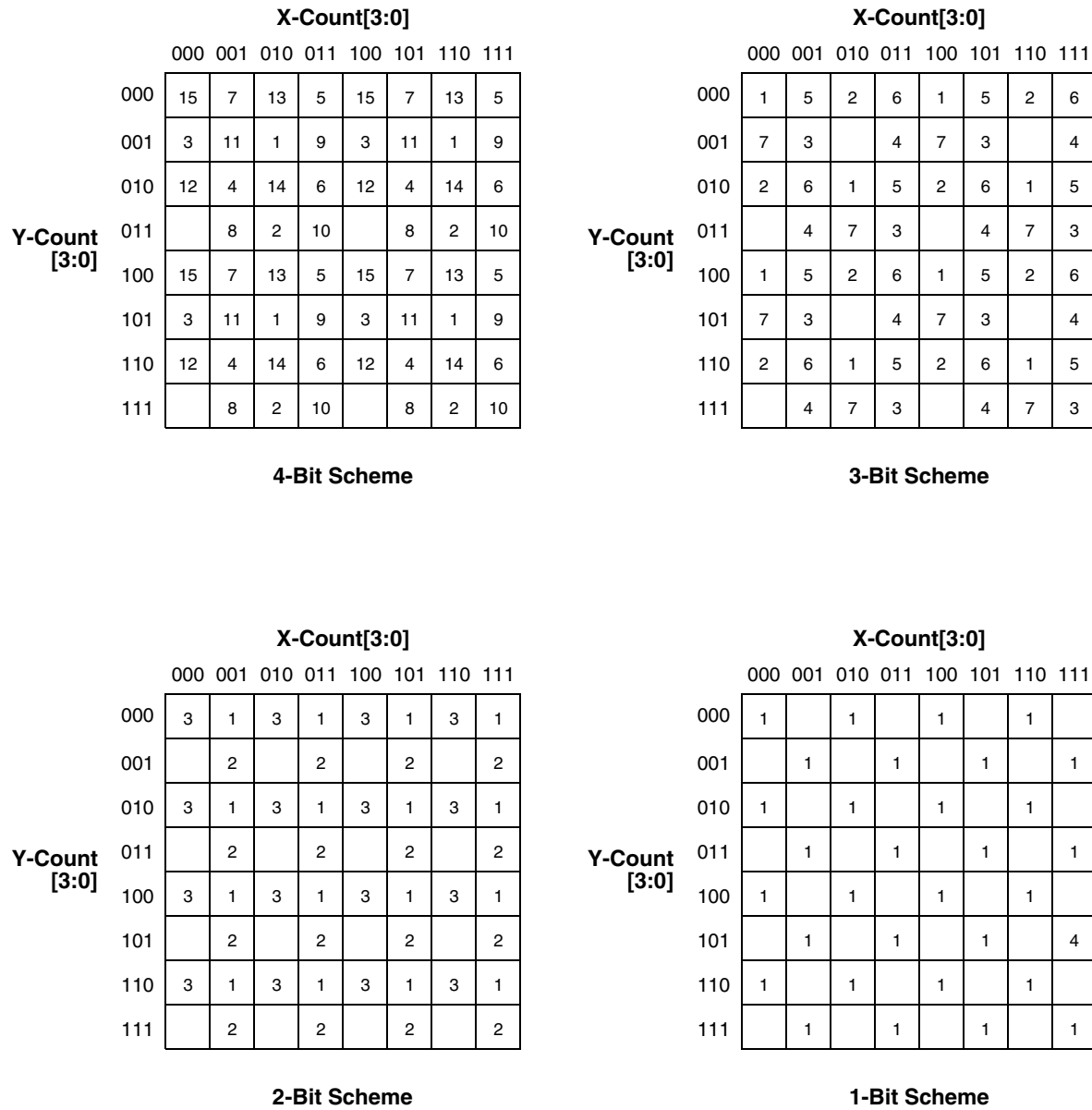


Figure 6-38. N-Bit Dithering Pattern Schemes

**CRC Signature**

The FP contains hardware/logic that performs Cyclical Redundancy Checks (CRCs) on the panel data digital pipeline. This feature is used for error detection and makes it possible to capture a unique 24- or 32-bit signature for any given mode setup. An error in the dither pixel pipeline produces a different signature when compared to a known good signature value. The dither data path can be configured in two basic modes: dither enable and dither disable by programming the DENB bit (FP Memory Offset 418h[0]). This allows the programmer to quickly and accurately test a video screen without having to visually inspect the screen for errors. Table 6-67 shows the bit settings that provide this feature.

Panel selection is done through FP Memory Offset 408h[18:16]. The selection of these bits results in two functions.

- 1) Generates the desired PANEL CLK from the pixel clock based on the panel type selected.
- 2) Steers the internal pixel bus on to the panel interface data pins. All the unused pins are driven with 0s.

This panel data is sent to the CRC signature generator.

The CRC number varies for each panel configuration for a fixed on-screen image.

**Table 6-67. Register Settings for Dither Enable/Disable Feature**

Dither Enable for TFT	Bypass Dither for TFT	Bypass FP
FP Memory Offset 418h[6:0] 000,001,1 001,010,1 010,011,1 011,100,1 100,101,1 101,xxx,x	FP Memory Offset 418h[6:0] 101,xxx,x	FP Memory Offset 408h[30] is set to 1

**Addressing the Dithering Memories**

The least significant four bits of each color component intensity value are used to select a 4x4 dithering pattern. In other words, there are 16 different 16-bit dithering patterns for each color component (red, green, and blue). This requires one 256x1-bit memory for each color component. The address to one of these dithering pattern memories is then eight bits in length.

The bit address for dithering memory is defined as the concatenation of:

- 1) The least significant two bits of the display screen horizontal position pixel count
- 2) The least significant two bits of the display screen vertical position pixel count
- 3) The least significant four bits of the input intensity value

This concatenation is as shown below:

$$\text{Dithering Memory Bit Address}[7:0] = \{X\text{-Count}[1:0], Y\text{-Count}[1:0], \text{Intensity}[3:0]\}$$

The FP GLIU interface programs the red, green, and blue dither memories individually, or all at once. Writing to all three dither memories at the same time means that the dithering patterns are the same for each of the three color components.

### 6.7.8 VP Resolution Table

Supported CRT and flat panel resolutions of the VP are provided in Table 6-32 on page 281. All resolutions can be up to 8 bits per color, or 24 bits per pixel. In general, all display resolutions contained in VESA Monitor Timing Specifications Version 1.0 v0.8 are supported for CRT. Flat panels up to 1600x1200x60 are supported. For those resolutions not listed in the VESA specification, the maximum dot clock frequency is 340 MHz for CRT and 170 MHz for TFT.

All SDTV and HDTV resolutions are also supported

### 6.7.9 Display RGB Modes

Mode overview:

1) CRT: Normal functional, CRT display.

- 2) TFT Online: Normal functional, TFT display.
- 3) CRT Legacy RGB: Use companion device as off-chip display controller, graphics only for CRT.
- 4) TFT Legacy RGB: Use the AMD Geode companion device as off-chip display controller, graphics only for CRT.
- 5) CRT Debug: Normal functional, access to debug signals. The DBG signals are driven on the specified pins outside the VP module, listed here for information only.
- 6) TFT Legacy RGB Debug: Use companion device as off-chip display controller, reduced graphics only for CRT, access to debug signals. The DBG signals are driven on the specified pins outside the VP module, listed here for information only.
- 7) VOP: Normal function

**Table 6-68. Display RGB Modes**

Pin	CRT 1	TFT ONLINE 2	CRT Legacy RGB 3	TFT Legacy RGB 4	CRT Debug 5	TFT LEGACY RGB Debug 6	VOP 7
DRGB23	0	TFT23	R7	R7	DBG15	DBG15	0
DRGB22	0	TFT22	R6	R6	DBG14	DBG14	0
DRGB21	0	TFT21	R5	R5	DBG13	DBG13	0
DRGB20	0	TFT20	R4	R4	DBG12	DBG12	0
DRGB19	0	TFT19	R3	R3	DBG11	DBG11	0
DRGB18	0	TFT18	0	R2	0	R7	0
DRGB17	0	TFT17	0	R1	0	R6	0
DRGB16	0	TFT16	0	R0	0	R5	0
DRGB15	0	TFT15	G7	G7	DBG10	DBG10	VOP8
DRGB14	0	TFT14	G6	G6	DBG09	DBG09	VOP9
DRGB13	0	TFT13	G5	G5	DBG08	DBG08	VOP10
DRGB12	0	TFT12	G4	G4	DBG07	DBG07	VOP11
DRGB11	0	TFT11	G3	G3	DBG06	DBG06	VOP12
DRGB10	0	TFT10	G2	G2	DBG05	DBG05	VOP13
DRGB9	0	TFT9	0	G1	0	G7	VOP14
DRGB8	0	TFT8	0	G0	0	G6	VOP15
DRGB7	0	TFT7	B7	B7	DBG04	DBG04	VOP0
DRGB6	0	TFT6	B6	B6	DBG03	DBG03	VOP1
DRGB5	0	TFT5	B5	B5	DBG02	DBG02	VOP2
DRGB4	0	TFT4	B4	B4	DBG01	DBG01	VOP3
DRGB3	0	TFT3	B3	B3	DBG00	DBG00	VOP4
DRGB2	0	TFT2	0	B2	0	G5	VOP5
DRGB1	0	TFT1	0	B1	0	B7	VOP6
DRGB0	0	TFT0	0	B0	0	B6	VOP7
DOTCLK	0	FP_SHFCLK	DF_DOT_CLK	DF_DOT_CLK	DBG_CLK	DF_DOT_CLK	VOPCLK
HSYNC	VP_HSYNC	FP_HSYNC	VG_HSYNC	VG_HSYNC	VP_HSYNC	VG_HSYNC	0
VSYNC	VP_VSYNC	FP_VSYNC	VG_VSYNC	VG_VSYNC	VP_VSYNC	VG_VSYNC	0
DISPEN	0	BKLEN	0	VG_DISP_EN	0	VG_DISP_EN	0
VDDEN	0	FP_VDDEN	0	0	0	0	0
LDEMOD	0	FP_LDE	0	0	0	0	0

## 6.8 Video Processor Register Descriptions

This section provides information on the registers associated with the Video Processor: Standard GeodeLink Device (GLD) and Video Processor Specific MSRs (accessed via the RDMSR and WRMSR instructions), and two blocks of functional memory mapped registers (Video Processor and Flat Panel).

Table 6-75 through Table 6-78 are register summary tables that include reset values and page references where the bit descriptions are provided.

**Note:** The MSR address is derived from the perspective of the CPU Core. See Section 4.1 "MSR Set" on page 45 for more details on MSR addressing.

For memory offset mapping details, see Section 4.1.3 "Memory and I/O Mapping" on page 47.

**Table 6-69. Standard GeodeLink™ Device MSRs Summary**

MSR Address	Type	Register Name	Reset Value	Reference
48002000h	RO	GLD Capabilities MSR (GLD_MSR_CAP)	00000000_0013F0xxh	Page 415
48002001h	R/W	GLD Master Configuration MSR (GLD_MSR_CONFIG)	00000000_00040E00h	Page 415
48002002h	R/W	GLD SMI MSR (GLD_MSR_SMI)	00000000_00000000h	Page 417
48002003h	R/W	GLD Error MSR (GLD_MSR_ERROR)	00000000_00000000h	Page 417
48002004h	R/W	GLD Power Management MSR (GLD_MSR_PM)	00000000_00000555h	Page 418
48002005h	R/W	GLD Diagnostic MSR (GLD_MSR_DIAG)	00000002_00000000h	Page 418

**Table 6-70. Video Processor Module Specific MSRs Summary**

MSR Address	Type	Register Name	Reset Value	Reference
48002010h	R/W	VP Diagnostic MSR (MSR_DIAG_VP)	00000000_00000000h	Page 419
48002011h	R/W	Pad Select MSR (MSR_PADSEL)	00000000_00000000h	Page 420

**Table 6-71. Video Processor Module Configuration Control Registers Summary**

VP Memory Offset	Type	Register Name	Reset Value	Reference
<b>Video Processor</b>				
000h	R/W	Video Configuration (VCFG)	00000000_00000000h	Page 421
008h	R/W	Display Configuration (DCFG)	00000000_00000000h	Page 422
010h	R/W	Video X Position (VX)	00000000_00000000h	Page 424
018h	R/W	Video Y Position (VY)	00000000_00000000h	Page 425
020h	R/W	Video Scale (SCL)	00000000_00000000h	Page 425
028h	R/W	Video Color Key Register (VCK)	00000000_00000000h	Page 426
030h	R/W	Video Color Mask (VCM)	00000000_00000000h	Page 427
038h	R/W	Palette Address (PAR)	00000000_000000xxh	Page 428
040h	R/W	Palette Data (PDR)	00000000_00xxxxxxh	Page 428
048h	R/W	Saturation Scale (SLR)	00000000_00000000h	Page 429

**Table 6-71. Video Processor Module Configuration Control Registers Summary (Continued)**

VP Memory Offset	Type	Register Name	Reset Value	Reference
050h	R/W	Miscellaneous (MISC)	00000000_00000C00h	Page 430
058h	R/W	CRT Clock Select (CCS)	00000000_00000000h	Page 431
060h	R/W	Video Y Scale (VYS)	00000000_00000000h	Page 431
068h	R/W	Video X Scale (VXS)	00000000_00000000h	Page 431
070h	--	Reserved (RSVD)	--	--
078h	R/W	Video Downscaler Control (VDC)	00000000_00000000h	Page 432
080h	--	Reserved	--	--
088h	R/W	CRC Signature (CRC)	00000000_00000000h	Page 433
090h	RO	32-Bit CRC Signature (CRC32)	00000000_00000001h	Page 434
098h	R/W	Video De-Interlacing and Alpha Control (VDE)	00000000_00000400h	Page 434
0A0h	R/W	Cursor Color Key (CCK)	00000000_00000000h	Page 436
0A8h	R/W	Cursor Color Mask (CCM)	00000000_00000000h	Page 437
0B0h	R/W	Cursor Color 1 (CC1)	00000000_00000000h	Page 437
0B8h	R/W	Cursor Color 2 (CC2)	00000000_00000000h	Page 438
0C0h	R/W	Alpha Window 1 X Position (A1X)	00000000_00000000h	Page 438
0C8h	R/W	Alpha Window 1 Y Position (A1Y)	00000000_00000000h	Page 439
0D0h	R/W	Alpha Window 1 Color (A1C)	00000000_00000000h	Page 439
0D8h	R/W	Alpha Window 1 Control (A1T)	00000000_00000000h	Page 440
0E0h	R/W	Alpha Window 2 X Position (A2X)	00000000_00000000h	Page 441
0E8h	R/W	Alpha Window 2 Y Position (A2Y)	00000000_00000000h	Page 442
0F0h	R/W	Alpha Window 2 Color (AC2)	00000000_00000000h	Page 442
0F8h	R/W	Alpha Window 2 Control (A2T)	00000000_00000000h	Page 443
100h	R/W	Alpha Window 3 X Position (A3X)	00000000_00000000h	Page 444
108h	R/W	Alpha Window 3 Y Position (A3Y)	00000000_00000000h	Page 445
110h	R/W	Alpha Window 3 Color (A3C)	00000000_00000000h	Page 445
118h	R/W	Alpha Window 3 Control (A3T)	00000000_00000000h	Page 446
120h	R/W	Video Request (VRR)	00000000_001B0017h	Page 447
128h	RO	Alpha Watch (AWT)	00000000_00000000h	Page 448
130h	R/W	Video Processor Test Mode (VTM)	00000000_00000000h	Page 448
138h	R/W	Even Video Y Position (VYE)	00000000_00000000h	Page 449
140h	R/W	Even Alpha Window 1 Y Position (A1YE)	00000000_00000000h	Page 449
148h	R/W	Even Alpha Window 2 Y Position (A2YE)	00000000_00000000h	Page 450
150h	R/W	Even Alpha Window 3 Y Position (A3YE)	00000000_00000000h	Page 450
158h-3FFh	--	Reserved	--	--

Table 6-71. Video Processor Module Configuration Control Registers Summary (Continued)

VP Memory Offset	Type	Register Name	Reset Value	Reference
<b>Flat Panel</b>				
400h	R/W	Panel Timing Register 1 (PT1)	00000000_00000000h	Page 451
408h	R/W	Panel Timing Register 2 (PT2)	00000000_00000000h	Page 453
410h	R/W	Power Management (PM)	00000000_00000002h	Page 454
418h	R/W	Dither and Frame Rate Control (DFC)	00000000_00000000h	Page 456
420h	--	Reserved	--	--
428h	--	Reserved	--	--
430h	--	Reserved	--	--
438h	--	Reserved	--	--
440h	--	Reserved	--	--
448h	R/W	Dither RAM Control and Address (DCA)	00000000_00000000h	Page 457
450h	R/W	Dither Memory Data (DMD)	00000000_00000000h	Page 458
458h	R/W	Panel CRC Signature (CRC)	00000000_00000000h	Page 458
460h	--	Reserved	--	--
468h	RO	32-Bit Panel CRC (CRC32)	00000000_00000001h	Page 459
<b>Video Output Port (VOP)</b>				
800h	R/W	Video Output Port Configuration (VOP_CONFIG)	00000000_00000000h	Page 459
808h	RO	Video Output Port Signature (VOP_SIG)	00000000_00000000h	Page 461
810h-8FFh	--	Reserved	--	--
1000h-1FFFh	R/W	Video Coefficient RAM (VCR)	xxxxxxxx_xxxxxxxh	Page 451

## 6.8.1 Standard GeodeLink™ Device MSRs

### 6.8.1.1 GLD Capabilities MSR (GLD\_MSR\_CAP)

MSR Address 48002000h  
 Type RO  
 Reset Value 00000000\_0013F0xxh

**GLD\_MSR\_CAP Register Map**

63	62	61	60	59	58	57	56	55	54	53	52	51	50	49	48	47	46	45	44	43	42	41	40	39	38	37	36	35	34	33	32
RSVD																															
31	30	29	28	27	26	25	24	23	22	21	20	19	18	17	16	15	14	13	12	11	10	9	8	7	6	5	4	3	2	1	0
RSVD								DEV_ID														REV_ID									

**GLD\_MSR\_CAP Bit Descriptions**

Bit	Name	Description
63:24	RSVD	<b>Reserved.</b> Reads back as 0.
23:8	DEV_ID	<b>Device ID.</b> Identifies device (13F0h).
7:0	REV_ID	<b>Revision ID.</b> Identifies device revision. See <i>AMD Geode™ LX Processors Specification Update</i> document for value.

### 6.8.1.2 GLD Master Configuration MSR (GLD\_MSR\_CONFIG)

MSR Address 48002001h  
 Type R/W  
 Reset Value 00000000\_00040E00h

**GLD\_MSR\_CONFIG Register Map**

63	62	61	60	59	58	57	56	55	54	53	52	51	50	49	48	47	46	45	44	43	42	41	40	39	38	37	36	35	34	33	32
RSVD																															
31	30	29	28	27	26	25	24	23	22	21	20	19	18	17	16	15	14	13	12	11	10	9	8	7	6	5	4	3	2	1	0
SP											VIDPRI	MSKCS	GPRI			FPC	IUV	DIV					FMTBO		FMT		PID				

**GLD\_MSR\_CONFIG Bit Descriptions**

Bit	Name	Description
63:32	RSVD (RO)	<b>Reserved (Read Only).</b> Reads back as 0.
31:21	SP	<b>Spares.</b> Bits are read/write, but have no function.
20	VIDPRI	<b>Video Priority.</b> Sets the video priority level to the video generator. If this bit is set the video stream will be put in high priority mode.
19	MSKCS	<b>Mask Palette Chip Select Fix.</b> If this bit is set, the fix for the chip select bug in the palette RAM is inactivated and the chip select remains active if the bypass both is not set. If this bit is clear, then the chip select is throttled on individual accesses to the RAM.
18:16	GPRI	<b>GLIU Master Priority.</b> 000 in this field sets the Video Processor module at the lowest GLIU priority and 111 sets the Video Processor module at the highest GLIU priority.

## GLD\_MSR\_CONFIG Bit Descriptions (Continued)

Bit	Name	Description
15	FPC	<b>Simultaneous Flat Panel (or VOP) and CRT.</b> Primary display is flat panel. Setting this bit activates the CRT DAC interface to allow simultaneous display of both panel and CRT. Leaving this bit reset forces the CRT DAC signals to zero.  This bit is ignored if bits [5:3] of this register are set to 0 or 4.
14	IUV	<b>Interchange UV.</b> Interchange byte order of the U and V bytes (see bits [7:6]). This applies only to DRGB mode (see bits [5:3]).
13:8	DIV	<b>Clock Divider.</b> GLIU clock divider to produce 14.3 MHz reference clock. Result must be equal to or less than 14.3 MHz. $GLIU\ clock\ speed / DIV = reference\ clock$ .
7:6	FMTBO	<b>Format Byte Order.</b> The lower 24 bits of the DRGB output bus byte order can be modified for any required interface. These bits, along with bit 14, are used to output the following combinations of byte order. This applies only to DRGB mode.  000 = RGB / YUV ( $Y C_b C_r$ ) 001 = BGR / VUY ( $C_r C_b Y$ ) 010 = BGR / VYU ( $C_r Y C_b$ ) 011 = BRG / VUY ( $C_r C_b Y$ ) 100 = RGB / YVU ( $Y C_r C_b$ ) 101 = BGR / VYU ( $C_r Y C_b$ ) 110 = BGR / VUY ( $C_r C_b Y$ ) 111 = BRG / VYU ( $C_r Y C_b$ )
5:3	FMT	<b>VP Output Format Select.</b> Video Processor module display outputs formatted for CRT or flat panel. Resets to CRT; software must change if a different mode is required.  000: CRT. 001: Flat Panel. 010: Reserved. 011: Reserved. 100: CRT Debug mode. 101: Reserved. 110: VOP. 111: DRGB.
2:0	PID	<b>VP Priority Domain.</b> Video Processor module assigned priority domain identifier.



**6.8.1.3 GLD SMI MSR (GLD\_MSR\_SMI)**

MSR Address 48002002h  
 Type R/W  
 Reset Value 00000000\_00000000h

The Video Processor does not produce SMI interrupts, therefore this register is not used. Always write 0.

**6.8.1.4 GLD Error MSR (GLD\_MSR\_ERROR)**

MSR Address 48002003h  
 Type R/W  
 Reset Value 00000000\_00000000h

**GLD\_MSR\_ERROR Register Map**

63	62	61	60	59	58	57	56	55	54	53	52	51	50	49	48	47	46	45	44	43	42	41	40	39	38	37	36	35	34	33	32
RSVD																															EM
31	30	29	28	27	26	25	24	23	22	21	20	19	18	17	16	15	14	13	12	11	10	9	8	7	6	5	4	3	2	1	0
RSVD																															EM

**GLD\_MSR\_ERROR Bit Descriptions**

Bit	Name	Description
63:33	RSVD (RO)	<b>Reserved (Read Only).</b> Reads back as 0.
32	E	<b>VP Error Status.</b> Any GLIU request made of an unsupported function type causes this bit to be set by the hardware. Writing a 1 to this bit clears the status. Bit 0 must be 0 for the error to be generated.  0: Error not pending. 1: Error pending.
31:1	RSVD (RO)	<b>Reserved (Read Only).</b>
0	EM	<b>DF Error Mask.</b>  0: Unmask the Error (i.e., error generation is enabled). 1: Mask the Error (i.e., error generation is disabled).

**6.8.1.5 GLD Power Management MSR (GLD\_MSR\_PM)**

MSR Address 48002004h  
 Type R/W  
 Reset Value 00000000\_00000555h

**GLD\_MSR\_PM Register Map**

63	62	61	60	59	58	57	56	55	54	53	52	51	50	49	48	47	46	45	44	43	42	41	40	39	38	37	36	35	34	33	32	
RSVD																																
31	30	29	28	27	26	25	24	23	22	21	20	19	18	17	16	15	14	13	12	11	10	9	8	7	6	5	4	3	2	1	0	
RSVD				SP				RSVD														PMD5	RSVD	PMD4	RSVD	PMD3	RSVD	PMD2	RSVD	PMD1	RSVD	PMD0

**GLD\_MSR\_PM Bit Descriptions**

Bit	Name	Description
63:28	RSVD	<b>Reserved.</b>
27:24	SP	<b>Spare.</b> Read/write, no function.
23:11	RSVD	<b>Reserved.</b>
10	PMD5	<b>VOP 2x Dot Clock Power Mode.</b> 0: Disable clock gating. Clocks are always ON. 1: Enable active hardware clock gating.
9	RSVD	<b>Reserved.</b>
8	PMD4	<b>VP Video Dot Clock Power Mode.</b> 0: Disable clock gating. Clocks are always ON. 1: Enable active hardware clock gating.
7	RSVD	<b>Reserved.</b>
6	PMD3	<b>FP Dot Clock Power Mode.</b> 0: Disable clock gating. Clocks are always ON. 1: Enable active hardware clock gating.
5	RSVD	<b>Reserved.</b>
4	PMD2	<b>FP GLIU Clock Power Mode.</b> 0: Disable clock gating. Clocks are always ON. 1: Enable active hardware clock gating.
3	RSVD	<b>Reserved.</b>
2	PMD1	<b>VP Graphics Dot Clock Power Mode.</b> 0: Disable clock gating. Clocks are always ON. 1: Enable active hardware clock gating.
1	RSVD	<b>Reserved.</b>
0	PMD0	<b>VP GLIU Clock Power Mode.</b> 0: Disable clock gating. Clocks are always ON. 1: Enable active hardware clock gating.

**6.8.1.6 GLD Diagnostic MSR (GLD\_MSR\_DIAG)**

MSR Address 48002005h  
 Type R/W  
 Reset Value 00000002\_00000000h

This register is reserved for internal use by AMD and should not be written to.

## 6.8.2 Video Processor Module Specific MSRs

### 6.8.2.1 VP Diagnostic MSR (MSR\_DIAG\_VP)

MSR Address 48002010h  
 Type R/W  
 Reset Value 00000000\_00000000h

**MSR\_DIAG\_VP Register Map**

63	62	61	60	59	58	57	56	55	54	53	52	51	50	49	48	47	46	45	44	43	42	41	40	39	38	37	36	35	34	33	32
RSVD																															
31	30	29	28	27	26	25	24	23	22	21	20	19	18	17	16	15	14	13	12	11	10	9	8	7	6	5	4	3	2	1	0
CM	NDM	SM	DVAL									D	TSEL					SP													

**MSR\_DIAG\_VP Bit Descriptions**

Bit	Name	Description
63:32	RSVD	<b>Reserved.</b>
31	CM	<b>32-Bit CRC Mode.</b> Selects 32-bit CRC generation. 0: Disable. 1: Enable.
30	NDM	<b>New Dither Mode.</b> Selects either the legacy dither mode, or new dither mode. The legacy dither mode has an errata with the first pixel. The new dither mode fixes this errata. This bit provided for backward compatibility. 0: Legacy dither mode. 1: New dither mode.
29:28	SM	<b>Sim Mode.</b> This field is used to put the VP in modes to aid verification. 00: Normal operation. 01: Graphics input bypasses VP and goes directly to FP. 10: Reserved. 11: Reserved.
27:20	DVAL	<b>DAC Test Value.</b> 8-bit data value to drive to CRT DAC when selected by bit 19. Duplicate copies of DAC Test Value are driven on DAC RGB. crt_dac_r[7:0] = DAC Test Value[7:0] ([27:20] is this register) crt_dac_g[7:0] = DAC Test Value[7:0] ([27:20] is this register) crt_dac_b[7:0] = DAC Test Value[7:0] ([27:20] is this register) To enable DAC Test Value to be driven to CRT DAC: (DAC Test Value Select must = 0) <b>AND</b> (VTM[6] = 0 AND MBD_MSR_DIAG[18:16] = 101h) OR (VTM[6] = 1 AND VTM[3:0] = 0001h)
19	D	<b>DAC Test Value Select.</b> Selects which data stream is sent to CRT DAC during CRT DAC test mode. 0: 24-bit data to CRT DAC = {3{DAC Test Value[27:20]}} (3 time repeated 8-bit value). 1: 24-bit data to CRT DAC = gfx_data[23:0] (raw input from Display Controller).
18:16	RSVD	<b>Reserved.</b> Reserved for test purposes. Set to 000 for normal operation.
15:0	SP	<b>Spares.</b> Read/write, no function.

**6.8.2.2 Pad Select MSR (MSR\_PADSEL)**

MSR Address 48002011h  
 Type R/W  
 Reset Value 00000000\_00000000h

**MSR\_PADSEL Register Map**

63	62	61	60	59	58	57	56	55	54	53	52	51	50	49	48	47	46	45	44	43	42	41	40	39	38	37	36	35	34	33	32
RSVD																							VOPCINV	RSVD	DF_DRGB[31:26]						
31	30	29	28	27	26	25	24	23	22	21	20	19	18	17	16	15	14	13	12	11	10	9	8	7	6	5	4	3	2	1	0
DF_DRGB[25:24]		RSVD	DF_DCLK	DF_DISP_EN	DF_LDE	DF_VSYNC	DF_HSYNC	DF_DRGB[23:0]																							

**MSR\_PADSEL Bit Descriptions**

Bit	Name	Description
63:40	RSVD	<b>Reserved.</b>
39	VOPCINV	<b>Invert VOP Clock.</b> This is used to invert the VOP output clock. This may be used to meet system timing requirements. 0: Non-inverted. 1: Inverted.
38	RSVD	<b>Reserved.</b>
37:0	PADS	<b>Select for Registered or Non-Registered VP Outputs.</b> Bits select whether to use the registers in the pad logic. The reset value of 38'b0 is valid for TFT 2 pixel per clock and CRT mode.  <b>Bits [37:30]: DF_DRGB[31:24]</b> 0: Registered output. 1: Direct output.  <b>Bit 29: RSVD.</b> Always write 0.  <b>Bit 28: DF_DCLK</b> <b>Bit 27: DF_DISP_EN</b> <b>Bit 26: DF_LDE</b> <b>Bit 25: DF_VSYNC</b> <b>Bit 24: DF_HSYNC</b> <b>Bits [23:0]: DF_DRGB[23:0]</b> 0: Registered output. 1: Direct output.

### 6.8.3 Video Processor Module Control/Configuration Registers

#### 6.8.3.1 Video Configuration (VCFG)

VP Memory Offset 000h

Type R/W

Reset Value 00000000\_00000000h

**VCFG Register Map**

63	62	61	60	59	58	57	56	55	54	53	52	51	50	49	48	47	46	45	44	43	42	41	40	39	38	37	36	35	34	33	32
RSVD																															
31	30	29	28	27	26	25	24	23	22	21	20	19	18	17	16	15	14	13	12	11	10	9	8	7	6	5	4	3	2	1	0
RSVD			EN_420	BIT_8_LINE_SIZE	BIT_9_LINE_SIZE	SP	INIT_RD_LN_SIZE	INIT_RD_ADDR								VID_LIN_SIZ								SP	SC_BYP	RSVD	VID_FMT	RSVD	VID_EN		

**VCFG Bit Descriptions**

Bit	Name	Description
63:29	RSVD (RO)	<b>Reserved (Read Only).</b> Reads back as 0.
28	EN_420	<b>Enable 4:2:0 Format.</b> 0: Disable. 1: Enable. <b>Note:</b> When the input video stream is RGB, this bit must be set to 0.
27	BIT_8_LINE_SIZE	<b>Bit 8 Line Size.</b> When enabled, this bit increases line size from VID_LIN_SIZ (bits [15:8]) DWORDs by adding 256 DWORDs. 0: Disable. 1: Enable.
26	BIT_9_LINE_SIZE	<b>Bit 9 Line Size.</b> When enabled, this bit increases line size from {BIT_8_LINE_SIZE, VID_LIN_SIZ (bits [15:8])} DWORDs by adding 512 DWORDs. 0: Disable. 1: Enable.
25	SP	<b>Spare.</b> Bit is R/W but has no function.
24	INIT_RD_LN_SIZE	<b>Increase Initial Buffer Read Address.</b> Increases INIT_RD_ADDR (bits [23:16]) by adding 256 DWORDs to the initial buffer address. (Effectively INIT_RD_ADDR becomes 9 bits (bits [24:16]) of address to the line buffers. Each line buffer location contains 4 pixels. Therefore INIT_RD_ADDR is restricted to 4 pixel resolution.) If sub-4 pixel start is desired, use the VP Memory Offset 010h[11:0]. 0: Disable. 1: Enable.
23:16	INIT_RD_ADDR	<b>Initial Buffer Read Address.</b> This field preloads the starting read address for the line buffers at the beginning of each display line. It is used for hardware clipping of the video window at the left edge of the active display. Since each line buffer contains 4 pixels, INIT_RD_ADDR is restricted to 4 pixel resolution. For an unclipped window, this value should be 0. For 420 mode, set bits [17:16] to 00.
15:8	VID_LIN_SIZ	<b>Video Line Size (in DWORDs).</b> Represents the number of DWORDs that make up the horizontal size of the source video data.
7:6	SP	<b>Spares.</b> Bits are R/W but have not function.

**VCFG Bit Descriptions (Continued)**

Bit	Name	Description
5	SC_BYP	<b>Scaler Bypass.</b> Bypass scaling math functions. Should only be used for non-scaled video outputs. Scale factors set to 10000h. 0: Scaler enabled. 1: Scaler disabled.
4	RSVD (RO)	<b>Reserved (Read Only).</b> Reads back as 0.
3:2	VID_FMT	<b>Video Format.</b> Byte ordering of video data on the video input bus. The interpretation of these bits depends on the settings for bit 28 (EN_420) and bit 13 (GV_SEL) of the VDE register (VP Memory Offset 098h).  If GV_SEL and EN_420 are both set to 0 (4:2:2): 00: Cb Y0 Cr Y1 01: Y1 Cr Y0 Cb 10: Y0 Cb Y1 Cr 11: Y0 Cr Y1 Cb  If GV_SEL is set to 0 and EN_420 is set to 1 (4:2:0): 00: Y0 Y1 Y2 Y3 01: Y3 Y2 Y1 Y0 10: Y1 Y0 Y3 Y2 11: Y1 Y2 Y3 Y0  If GV_SEL is set to 1 and EN_420 is set to 0 (5:6:5): 00: P1L P1M P2L P2M 01: P2M P2L P1M P1L 10: P1M P1L P2M P2L 11: P1M P2L P2M P1L  Both RGB 5:6:5 and YUV 4:2:2 contain two pixels in each 32-bit DWORD. YUV 4:2:0 contains a stream of Y data for each line, followed by U and V data for that same line. Cb = u, Cr = v.
1	RSVD (RO)	<b>Reserved (Read Only).</b> Reads back as 0.
0	VID_EN	<b>Video Enable.</b> Enables video acceleration hardware. 0: Disable (reset) video module. 1: Enable.

**6.8.3.2 Display Configuration (DCFG)**

VP Memory Offset 008h  
 Type R/W  
 Reset Value 00000000\_00000000h

**DCFG Register Map**

63	62	61	60	59	58	57	56	55	54	53	52	51	50	49	48	47	46	45	44	43	42	41	40	39	38	37	36	35	34	33	32	
RSVD																																
31	30	29	28	27	26	25	24	23	22	21	20	19	18	17	16	15	14	13	12	11	10	9	8	7	6	5	4	3	2	1	0	
SP				RSVD	DAC_VREF	RSVD					GV_GAM	VG_CK	RSVD				CRT_SYNC_SKW	SP				CRT_VSYNC_POL	CRT_HSYNC_POL	RSVD			SP		DAC_BL_EN	VSYNC_EN	HSYNC_EN	CRT_EN

## DCFG Bit Descriptions

Bit	Name	Description
63:32	RSVD (RO)	<b>Reserved (Read Only).</b> Reads back as 0.
31:28	SP	<b>Spares.</b> Bits are read/write, but have no function.
27	RSVD (RO)	<b>Reserved (Read Only).</b> Reads back as 0.
26	DAC_VREF	<b>Select CRT DAC VREF.</b> Allows use of an external voltage reference for CRT DAC. 0: Disable external VREF. 1: Use external VREF.
25:22	RSVD (RO)	<b>Reserved (Read Only).</b> Reads back as 0.
21	GV_GAM	<b>Graphics/Video Gamma.</b> Selects whether the graphic or video data should pass through the Gamma Correction RAM. 0: Graphic data passes through the Gamma Correction RAM. 1: Video data passes through the Gamma Correction RAM.
20	VG_CK	<b>Video/Graphics Color Key Select.</b> Selects whether the graphic data is used for color-keying or the video data is used for chroma-keying. Note that this affects the final output with or without blending enabled. See Figure 6-31 on page 438 and Table 6-64 on page 439 for details. 0: Graphic data is compared to the color key. 1: Video data is compared to the chroma key.
19:17	RSVD (RO)	<b>Reserved (Read Only).</b> Reads back as 0.
16:14	CRT_SYNC_SKW	<b>CRT Sync Skew.</b> Represents the number of pixel clocks to skew the horizontal and vertical sync that are sent to the CRT. This field should be programmed to 100 (i.e., baseline sync is not moved) as the baseline. Via this register, the sync can be moved forward (later) or backward (earlier) relative to the pixel data. This register can be used to compensate for possible delay of pixel data being processed via the Video Processor. 000: Sync moved 4 clocks backward. 001: Sync moved 3 clocks backward. 010: Sync moved 2 clocks backward. 011: Sync moved 1 clock backward. 100: Baseline sync is not moved. (Default) 101: Sync moved 1 clock forward. 110: Sync moved 2 clocks forward. 111: Sync moved 3 clocks forward.
13:10	SP	<b>Spares.</b> Bits are read/write, but have no function.
9	CRT_VSYNC_POL	<b>CRT Vertical Synchronization Polarity.</b> Selects the polarity for CRT vertical sync. 0: CRT vertical sync is normally low and is set high during the sync interval. 1: CRT vertical sync is normally high and is set low during the sync interval
8	CRT_HSYNC_POL	<b>CRT Horizontal Synchronization Polarity.</b> Selects the polarity for CRT horizontal sync. 0: CRT horizontal sync is normally low and is set high during sync interval. 1: CRT horizontal sync is normally high and is set low during sync interval.
7:6	RSVD (RO)	<b>Reserved (Read Only).</b> Reads back as 0.
5:4	SP	<b>Spares.</b> Bits are read/write, but have no function.
3	DAC_BL_EN	<b>DAC Blank Enable.</b> Controls blanking of the CRT DACs. 0: DACs are constantly blanked. 1: DACs are blanked normally (i.e., during horizontal and vertical blank).

## DCFG Bit Descriptions (Continued)

Bit	Name	Description
2	VSYNC_EN	<b>CRT Vertical Sync Enable.</b> Enables/disables CRT vertical sync (used for VESA DPMS support). 0: Disable. 1: Enable.
1	HSYNC_EN	<b>CRT Horizontal Sync Enable.</b> Enables/disables CRT horizontal sync (used for VESA DPMS support). 0: Disable. 1: Enable.
0	CRT_EN	<b>CRT Enable.</b> Enables the graphics display control logic. This bit is also used to reset the display logic. 0: Reset display control logic. 1: Enable display control logic.

## 6.8.3.3 Video X Position (VX)

VP Memory Offset 010h

Type R/W

Reset Value 00000000\_00000000h

## VX Register Map

63	62	61	60	59	58	57	56	55	54	53	52	51	50	49	48	47	46	45	44	43	42	41	40	39	38	37	36	35	34	33	32
RSVD																															
31	30	29	28	27	26	25	24	23	22	21	20	19	18	17	16	15	14	13	12	11	10	9	8	7	6	5	4	3	2	1	0
RSVD				VID_X_END												RSVD				VID_X_START											

## VX Bit Descriptions

Bit	Name	Description
63:28	RSVD (RO)	<b>Reserved (Read Only).</b> Reads back as 0.
27:16	VID_X_END	<b>Video X End Position.</b> Represents the horizontal end position of the video window. This register is programmed relative to CRT horizontal sync input (not the physical screen position). This value is calculated according to the following formula: Value = Desired screen position + (H_TOTAL – H_SYNC_END) – 13. (Note 1)
15:12	RSVD (RO)	<b>Reserved (Read Only).</b> Reads back as 0.
11:0	VID_X_START	<b>Video X Start Position.</b> Represents the horizontal start position of the video window. This value is calculated according to the following formula: Value = Desired screen position + (H_TOTAL – H_SYNC_END) – 14. (Note 1)

Note 1. H\_TOTAL and H\_SYNC\_END are the values written in the Display Controller module registers.



**6.8.3.4 Video Y Position (VY)**

VP Memory Offset 018h

Type R/W

Reset Value 00000000\_00000000h

**VY Register Map**

63	62	61	60	59	58	57	56	55	54	53	52	51	50	49	48	47	46	45	44	43	42	41	40	39	38	37	36	35	34	33	32
RSVD																															
31	30	29	28	27	26	25	24	23	22	21	20	19	18	17	16	15	14	13	12	11	10	9	8	7	6	5	4	3	2	1	0
RSVD				VID_Y_END												RSVD				VID_Y_START											

**VY Bit Descriptions**

Bit	Name	Description
63:27	RSVD (RO)	<b>Reserved (Read Only).</b> Reads back as 0.
26:16	VID_Y_END	<b>Video Y End Position.</b> Represents the vertical end position of the video window. This value is calculated according to the following formula: Value = Desired screen position + (V_TOTAL – V_SYNC_END) + 2. (Note 1)
15:11	RSVD (RO)	<b>Reserved (Read Only).</b> Reads back as 0.
10:0	VID_Y_START	<b>Video Y Start Position.</b> Represents the vertical start position of the video window. This register is programmed relative to CRT Vertical sync input (not the physical screen position). This value is calculated according to the following formula: Value = Desired screen position + (V_TOTAL – V_SYNC_END) + 1. (Note 1)

Note 1. V\_TOTAL and V\_SYNC\_END are the values written in the Display Controller module registers.

**6.8.3.5 Video Scale (SCL)**

VP Memory Offset 020h

Type R/W

Reset Value 00000000\_00000000h

**SCL Register Map**

63	62	61	60	59	58	57	56	55	54	53	52	51	50	49	48	47	46	45	44	43	42	41	40	39	38	37	36	35	34	33	32			
RSVD																																		
31	30	29	28	27	26	25	24	23	22	21	20	19	18	17	16	15	14	13	12	11	10	9	8	7	6	5	4	3	2	1	0			
GP	GP	RSVD														SP	DID	COED	LPS	SP	VSL													

**SCL Bit Descriptions**

Bit	Name	Description
63:32	RSVD (RO)	<b>Reserved (Read Only).</b> Reads back as 0.
31	GP (RO)	<b>GLIU Passed (Read Only).</b> This bit set indicates the GLIU line buffer fill has been passed by the Dot display. Screen display tearing might occur. This bit clears on read.  This bit is typically set if during vertical downscale, the 2nd line buffer fill hasn't started before the Dot display has started. This indicates an error in that the GLIU line buffer fill can't keep up with the Dot clock display rate.

**SCL Bit Descriptions**

Bit	Name	Description
30	GB (RO)	<b>GLIU Behind (Read Only).</b> This bit set indicates the GLIU line buffer fill is falling behind the Dot display. This bit clears on read.  This bit is typically set if during vertical downscale, the 2nd line buffer fill has not completed before the Dot display has started. This does not necessarily indicate an error, recovery is possible.
29:16	RSVD	<b>Reserved.</b>
15	SP	<b>Spare.</b> Bit is R/W but has no function.
14	DHD	<b>Double Horizontal Downscale.</b> Selects which method data gets written into line buffers. 0: Write data from video interface directly. 1: Write data from video interface averaged each 2 pixels.  This bit should only be set when horizontal downscale greater than 4:1 is desired.
13	COED	<b>Coefficient Mode.</b> Selects between 128 and 256 coefficient usage. 0: Use common 256 vert/horz coefficient table. 1: Use separate 128 vert/horz coefficient tables.  When using separate tables, the vertical coefficient should be placed in the lower half of the coefficient RAM (0-127 = vertical 128-255 = horizontal).
12	LPS	<b>Last Pixel Select.</b> Selects method to choose last pixel for the scaler to use. 0: Use video source line size. 1: Use video window size.  The preferred setting is 0. This will avoid unnecessary horizontal mirroring.
11	SP	<b>Spare.</b> Bit is R/W but has no function.
10:0	VSL	<b>Video Source Lines.</b> Represents the total number of video source lines. For example, a 720x480 video image would have VSL = 480.

**6.8.3.6 Video Color Key Register (VCK)**

VP Memory Offset 028h

Type R/W

Reset Value 00000000\_00000000h

**VCK Register Map**

63	62	61	60	59	58	57	56	55	54	53	52	51	50	49	48	47	46	45	44	43	42	41	40	39	38	37	36	35	34	33	32
RSVD																															
31	30	29	28	27	26	25	24	23	22	21	20	19	18	17	16	15	14	13	12	11	10	9	8	7	6	5	4	3	2	1	0
RSVD								VID_CLR_KEY																							

**VCK Bit Descriptions**

Bit	Name	Description
63:24	RSVD (RO)	<b>Reserved (Read Only).</b> Reads back as 0.

## VCK Bit Descriptions (Continued)

Bit	Name	Description
23:0	VID_CLR_KEY	<p><b>Video Color Key.</b> The video color key is a 24-bit RGB or YUV value.</p> <ul style="list-style-type: none"> <li>If VG_CK (VP Memory Offset 008h[20]) is set to 0, the video pixel is selected within the target window if the corresponding graphics pixel matches the color key. The color key is an RGB value.</li> <li>If VG_CK (VP Memory Offset 008h[20]) is set to 1, the video pixel is selected within the target window only if it (the video pixel) does not match the color key. The color key is usually an RGB value. However, if both GV_SEL and CSC_VIDEO (VP Memory Offset 098[13,10]) are set to 0, the color key is a YUV value (i.e., video is not converted to RGB).</li> </ul> <p>The graphics or video data being compared can be masked prior to the compare via the Video Color Mask register (VP Memory Offset 030h). The video color key can be used to allow irregular shaped overlays of graphics onto video, or video onto graphics, within a scaled video window.</p>

## 6.8.3.7 Video Color Mask (VCM)

VP Memory Offset 030h

Type R/W

Reset Value 00000000\_00000000h

## VCM Register Map

63	62	61	60	59	58	57	56	55	54	53	52	51	50	49	48	47	46	45	44	43	42	41	40	39	38	37	36	35	34	33	32
RSVD																															
31	30	29	28	27	26	25	24	23	22	21	20	19	18	17	16	15	14	13	12	11	10	9	8	7	6	5	4	3	2	1	0
RSVD								VID_CLR_MASK																							

## VCM Bit Descriptions

Bit	Name	Description
63:24	RSVD (RO)	<b>Reserved (Read Only).</b> Reads back as 0.
23:0	VID_CLR_MASK	<p><b>Video Color Mask.</b> This mask is a 24-bit RGB value. Zeros in the mask cause the corresponding bits in the graphics or video stream to be forced to match.</p> <p>For example:</p> <p>A mask of FFFFFFFh causes all 24 bits to be compared (single color match).</p> <p>A mask of 000000h causes none of the 24 bits to be compared (all colors match).</p> <p>For more information about the color key, see VP Memory Offset 028h on page 426. The video color mask is used to mask bits of the graphics or video stream being compared to the color key. It allows a range of values to be used as the color key.</p>

**6.8.3.8 Palette Address (PAR)**

VP Memory Offset 038h

Type R/W

Reset Value 00000000\_000000xxh

**PAR Register Map**

63	62	61	60	59	58	57	56	55	54	53	52	51	50	49	48	47	46	45	44	43	42	41	40	39	38	37	36	35	34	33	32
RSVD																															
31	30	29	28	27	26	25	24	23	22	21	20	19	18	17	16	15	14	13	12	11	10	9	8	7	6	5	4	3	2	1	0
RSVD																								PAL_ADDR							

**PAR Bit Descriptions**

Bit	Name	Description
63:8	RSVD (RO)	<b>Reserved (Read Only).</b> Reads back as 0.
7:0	PAL_ADDR	<b>Gamma Address.</b> Specifies the address to be used for the next access to the Palette Data register (VP Memory Offset 040h[23:0]). Each access to the PDR automatically increments the PAR. If non-sequential access is made to the palette, the PAR must be loaded between each non-sequential data block.

**6.8.3.9 Palette Data (PDR)**

VP Memory Offset 040h

Type R/W

Reset Value 00000000\_00xxxxxxh

**PDR Register Map**

63	62	61	60	59	58	57	56	55	54	53	52	51	50	49	48	47	46	45	44	43	42	41	40	39	38	37	36	35	34	33	32
RSVD																															
31	30	29	28	27	26	25	24	23	22	21	20	19	18	17	16	15	14	13	12	11	10	9	8	7	6	5	4	3	2	1	0
RSVD																PAL_DATA															

**PDR Bit Descriptions**

Bit	Name	Description
63:24	RSVD (RO)	<b>Reserved (Read Only).</b> Reads back as 0.
23:0	PAL_DATA	<b>Palette Data.</b> Contains the read or write data for a Gamma Correction RAM (palette). Provides the video palette data. The data can be read or written to the Gamma Correction RAM (palette) via this register. Prior to accessing this register, an appropriate address should be loaded to the PAR (VP Memory Offset 038h[7:0]). Subsequent accesses to the PDR cause the internal address counter to be incremented for the next cycle.  <b>Note:</b> When a read or write to the Gamma Correction RAM occurs, the previous output value is held for one additional DOTCLK period. This effect should go unnoticed during normal operation.

**6.8.3.10 Saturation Scale (SLR)**

VP Memory Offset 048h

Type R/W

Reset Value 00000000\_00000000h

**SLR Register Map**

63	62	61	60	59	58	57	56	55	54	53	52	51	50	49	48	47	46	45	44	43	42	41	40	39	38	37	36	35	34	33	32
RSVD																															
31	30	29	28	27	26	25	24	23	22	21	20	19	18	17	16	15	14	13	12	11	10	9	8	7	6	5	4	3	2	1	0
RSVD																					EN	SPARE	SAT_SCALE								

**SLR Bit Descriptions**

Bit	Name	Description
63:10	RSVD (RO)	<b>Reserved (Read Only).</b> Reads back as 0.
9	EN	<b>Enable.</b> Enable Saturation Scaling. If this bit is cleared, saturation conversion does not occur. If it is set, saturation conversion and scaling occurs prior to YUV conversion of the graphics.
8	SPARE	<b>SPARE.</b> Bit is R/W but has no function.
7:0	SAT_SCALE	<b>Saturation Scale.</b> Saturation scale value set by software to scale the saturation value derived by the RGB to HSV conversion of the graphics. After scaling the S value, the result is then converted to YUV format prior to blending with the video. This 8-bit value represents 256 equal steps between 0 and 1.

**6.8.3.11 Miscellaneous (MISC)**

VP Memory Offset 050h  
 Type R/W  
 Reset Value 00000000\_00000C00h

**MISC Register Map**

63	62	61	60	59	58	57	56	55	54	53	52	51	50	49	48	47	46	45	44	43	42	41	40	39	38	37	36	35	34	33	32
RSVD																															
31	30	29	28	27	26	25	24	23	22	21	20	19	18	17	16	15	14	13	12	11	10	9	8	7	6	5	4	3	2	1	0
RSVD																		SP	APWRDN	DACPWRDN	RSVD										BYP_BOTH

**MISC Bit Descriptions**

Bit	Name	Description
63:13	RSVD (RO)	<b>Reserved (Read Only).</b> Reads back as 0.
12	SP	<b>Spare.</b> Read/write; no function.
11	APWRDN	<b>Analog Interface Power Down.</b> Enables power down of the analog section of the internal CRT DAC. 0: Normal. 1: Power down.
10	DACPWRDN	<b>DAC Power Down.</b> Enables power down of the digital section of the internal CRT DAC. For this bit to take effect: VP Memory Offset 130h[6] must be = 1 or MSR Address 48000010h[18:16] must not equal 101. 0: Normal. 1: Power down.
9:1	RSVD (RO)	<b>Reserved (Read Only).</b> Reads back as 0.
0	BYP_BOTH	<b>Bypass Both.</b> Indicates if both graphics and video data should bypass gamma correction RAM. 0: The stream selected by the Display Configuration (DCFG) register (VP Memory Offset 008h[21]) is passed through gamma correction RAM. 1: Both graphics and video bypass gamma correction RAM.

**6.8.3.12 CRT Clock Select (CCS)**

VP Memory Offset 058h  
 Type R/W  
 Reset Value 00000000\_00000000h

This register is made up of read only reserved bits and spare bits with no functions.

**6.8.3.13 Video Y Scale (VYS)**

VP Memory Offset 060h  
 Type R/W  
 Reset Value 00000000\_00000000h

**VYS Register Map**

63	62	61	60	59	58	57	56	55	54	53	52	51	50	49	48	47	46	45	44	43	42	41	40	39	38	37	36	35	34	33	32
RSVD																															
31	30	29	28	27	26	25	24	23	22	21	20	19	18	17	16	15	14	13	12	11	10	9	8	7	6	5	4	3	2	1	0
Y_ACC_INIT												VID_Y_SCL																			

**VYS Bit Descriptions**

Bit	Name	Description
63:32	RSVD (RO)	<b>Reserved (Read Only).</b> Reads back as 0.
31:20	Y_ACC_INIT	<b>Y Accumulator Initial Value.</b> Load this value before each video frame. Works with vertical scaling, in case a sub-line offset is required prior to displaying video. Pad 4 LSBs with 0 when loading.
19:0	VID_Y_SCL	<p><b>Video Y Scale Factor.</b> Bits [19:16] represent the integer part of vertical scale factor of the video window according to the following formula:</p> $Y\_SCL\_INT = 1/Y_s$ <p>Where:</p> <p><math>Y_s</math> = Arbitrary vertical scaling factor.</p> <p>Bits [15:0] represent the fractional part of vertical scale factor of the video window according to the following formula:</p> $VID\_Y\_SCL = FFFFh * 1/Y_s$ <p><b>Note:</b> If no scaling is intended, set to 10000h. Will be greater than 10000h when down-scaling. Will be less than 10000h when upscaling.</p>

**6.8.3.14 Video X Scale (VXS)**

VP Memory Offset 068h  
 Type R/W  
 Reset Value 00000000\_00000000h

**VXS Register Map**

63	62	61	60	59	58	57	56	55	54	53	52	51	50	49	48	47	46	45	44	43	42	41	40	39	38	37	36	35	34	33	32
RSVD																															
31	30	29	28	27	26	25	24	23	22	21	20	19	18	17	16	15	14	13	12	11	10	9	8	7	6	5	4	3	2	1	0
X_ACC_INIT												VID_X_SCL																			

## VXS Bit Descriptions

Bit	Name	Description
63:32	RSVD (RO)	<b>Reserved (Read Only).</b> Reads back as 0.
31:20	X_ACC_INIT	<b>X Accumulator Initial Value.</b> Load this value before each video line. Works with horizontal scaling, in case a sub-pixel offset is required prior to displaying video. Pad 4 LSBs with 0 when loading.
19:0	VID_X_SCL	<p><b>Video X Scale Factor.</b> Bits [19:16] represent the integer part of horizontal scale factor of the video window according to the following formula:</p> $X\_SCL\_INT = 1/Xs$ <p>Where:</p> <p>Xs = Arbitrary horizontal scaling factor.</p> <p>Bits [5:0] represent the fractional part of horizontal scale factor of the video window according to the following formula:</p> $VID\_X\_SCL = FFFFh * 1/Xs$ <p><b>Note:</b> If no scaling is intended, set to 10000h. Will be greater than 1000h when down-scaling. Will be less than 10000h when upscaling.</p>

## 6.8.3.15 Video Downscaler Control (VDC)

VP Memory Offset 078h

Type R/W

Reset Value 00000000\_00000000h

## VDC Register Map

63	62	61	60	59	58	57	56	55	54	53	52	51	50	49	48	47	46	45	44	43	42	41	40	39	38	37	36	35	34	33	32
RSVD																															
31	30	29	28	27	26	25	24	23	22	21	20	19	18	17	16	15	14	13	12	11	10	9	8	7	6	5	4	3	2	1	0
RSVD																							DTS	RSVD	DFS			DCF			

## VDC Bit Descriptions

Bit	Name	Description
63:7	RSVD (RO)	<b>Reserved (Read Only).</b> Reads back as 0.
6	DTS	<p><b>Downscale Type Select.</b></p> <p>0: Type A (downscale formula is <math>1/m + 1</math>, m pixels are dropped, one pixel is kept).</p> <p>1: Type B (downscale formula is <math>m/m + 1</math>, m pixels are kept, one pixel is dropped).</p>
5	RSVD (RO)	<b>Reserved (Read Only).</b> Reads back as 0.
4:1	DFS	<p><b>Downscale Factor Select.</b> Determines the downscale factor to be programmed into these bits, where m is used to derive the desired downscale factor depending on bit 6 (DTS). Only values up to 7 are valid.</p>
0	DCF	<p><b>Downscaler and Filtering.</b> Enables/disables downscaler and filtering logic.</p> <p>0: Disable.</p> <p>1: Enable.</p>



**6.8.3.16 CRC Signature (CRC)**

VP Memory Offset 088h

Type R/W

Reset Value 00000000\_00000000h

**CRC Register Map**

63	62	61	60	59	58	57	56	55	54	53	52	51	50	49	48	47	46	45	44	43	42	41	40	39	38	37	36	35	34	33	32
RSVD																															
31	30	29	28	27	26	25	24	23	22	21	20	19	18	17	16	15	14	13	12	11	10	9	8	7	6	5	4	3	2	1	0
RSVD																													SIGVAL	SIGFR	SIGEN

**CRC Bit Descriptions**

Bit	Name	Description
63:3	RSVD (RO)	<b>Reserved (Read Only).</b> Reads back as 0.
2	SIGVAL (RO)	<b>Signature Valid (Read Only).</b> If this bit is set, the signature operation has completed and the signature may be safely read from the 32-Bit CRC Signature Register (VP Memory Offset 090h).
1	SIGFR	<b>Signature Free Run.</b> 0: Disable. (Default). If this bit was previously set to 1, the signature process will stop at the end of the current frame (i.e., at the next falling edge of VSYNC). 1: Enable. If SIGEN (bit 0) is set to 1, the signature register captures data continuously across multiple frames.
0	SIGEN	<b>Signature Enable.</b> 0: Disable. The SIGVAL (bits [31:8]) is reset to 000001h in 24-bit mode or 000000h in 32-bit mode and held (no capture). (Default) 1: Enable. When this bit is set to 1, the next falling edge of VSYNC is counted as the start of the frame to be used for CRC checking with each pixel clock beginning with the next VSYNC. If SIGFR (bit 1) is set to 1, the signature register captures the pixel data signature continuously across multiple frames. If SIGFR (bit 1) is cleared to 0, a signature is captured one frame at a time, starting from the next falling VSYNC. After a signature capture is complete, the SIGVAL (bit 2) can be read to determine the CRC check status. In 32-bit CRC mode, the full 32-bit signature can be read from the 32-Bit CRC Signature (VP Memory Offset 090h[31:0]). Then proceed to reset SIGEN, which initializes SIGVAL as an essential preparation for the next round of CRC checks.

**6.8.3.17 32-Bit CRC Signature (CRC32)**

VP Memory Offset 090h  
 Type RO  
 Reset Value 00000000\_00000001h

**CRC32 Register Map**

63	62	61	60	59	58	57	56	55	54	53	52	51	50	49	48	47	46	45	44	43	42	41	40	39	38	37	36	35	34	33	32
RSVD																															
31	30	29	28	27	26	25	24	23	22	21	20	19	18	17	16	15	14	13	12	11	10	9	8	7	6	5	4	3	2	1	0
SIG_VALUE																															

**CRC32 Bit Descriptions**

Bit	Name	Description
63:32	RSVD (RO)	<b>Reserved (Read Only).</b> Reads back as 0.
31:0	SIG_VALUE (RO)	<b>Signature Value (Read Only).</b> A 32-bit signature value is stored in this field when in 32-bit CRC mode and can be read at any time. The 32-bit CRC mode select bit is located in VP Diagnostic MSR (MSR 48000010h[31]). The signature is produced from the RGB data before it is sent to the CRT DACs. This field is used for test purposes only. See VP Memory Offset 088h for more information.

**6.8.3.18 Video De-Interlacing and Alpha Control (VDE)**

VP Memory Offset 098h  
 Type R/W  
 Reset Value 00000000\_00000400h

**VDE Register Map**

63	62	61	60	59	58	57	56	55	54	53	52	51	50	49	48	47	46	45	44	43	42	41	40	39	38	37	36	35	34	33	32
RSVD																															
31	30	29	28	27	26	25	24	23	22	21	20	19	18	17	16	15	14	13	12	11	10	9	8	7	6	5	4	3	2	1	0
RSVD										A3P	A2P	A1P	ALPHA_DRBG	VID_ALPHA_EN	GV_SEL	CSC_VOP	CSC_GFX	CSC_VIDEO	HDSD	GFX_INS_VIDEO	YUV_CSC_EN	HDSD_VIDEO	RSVD	SP	RSVD	SP					

**VDE Bit Descriptions**

Bit	Name	Description
63:22	RSVD (RO)	<b>Reserved (Read Only).</b> Reads back as 0.
21:20	A3P	<b>Alpha Window 3 Priority.</b> Indicates the priority of alpha window 3. A higher number indicates a higher priority. Priority is used to determine display order for overlapping alpha windows.  This field is reset by hardware to 00.
19:18	A2P	<b>Alpha Window 2 Priority.</b> Indicates the priority of alpha window 2. A higher number indicates a higher priority. Priority is used to determine display order for overlapping alpha windows.  This field is reset by hardware to 00.

## VDE Bit Descriptions (Continued)

Bit	Name	Description
17:16	A1P	<b>Alpha Window 1 Priority.</b> Indicates the priority of alpha window 1. A higher number indicates a higher priority. Priority is used to determine display order for overlapping alpha windows.  This field is reset by hardware to 00.
15	ALPHA_DRGB	<b>Enable Alpha on DRGB[31:24].</b> The source of the alpha value is the upper 8 bits [31:24] of the graphics input bus. When this bit is set, the upper 8 bits of the graphics input bus is passed through to the upper 8 bits [31:24] of the DRGB output bus. If bit 14 is also set, the actual video blended alpha value replaces the graphics alpha value when inside an alpha window.  00: DRGB[31:24] are not driven. 01: DRGB[31:24] are not driven. 10: DRGB[31:24] contain contents of graphics input bus [31:24]. 11: DRGB[31:24] contain contents of graphics input bus [31:24] when NOT inside any alpha window; inside any alpha window, DRGB[31:24] contains actual video alpha value.
14	VID_ALPHA_EN	<b>Enable Video Alpha value onto DRGB[31:24].</b> When inside an alpha window, drive the video alpha value (graphics per-pixel alpha value multiplied by the multiplier) onto bits [31:24] of the DRGB output bus.  00: DRGB[31:24] are not driven. 01: DRGB[31:24] are not driven. 10: DRGB[31:24] contain contents of graphics input bus [31:24]. 11: DRGB[31:24] contain contents of graphics input bus [31:24] when NOT inside any alpha window; inside any alpha window, DRGB[31:24] contains actual video alpha value.
13	GV_SEL	<b>Graphics Video Select.</b> Selects input video format.  0: YUV format. 1: RGB format.  If this bit is set to 1, bit EN_420 (VP Memory Offset 000h[28]) must be set to 0.
12	CSC_VOP	<b>Color Space Converter for VOP.</b> Determines whether or not the output from the blender is passed through the Color Space Converter (CSC) before entering the VOP.  0: Disable. The output of the blender is sent “as is” to the mixer/blender. 1: Enable. The output of the blender is passed through the CSC (for RGB to YUV conversion).
11	CSC_GFX	<b>Color Space Converter for Graphics.</b> Determines whether or not the graphics stream is passed through the Color Space Converter (CSC).  0: Disable. The graphics stream is sent “as is” to the mixer/blender. 1: Enable. The graphics stream is passed through the CSC (for RGB to YUV conversion).
10	CSC_VIDEO	<b>Color Space Converter for Video.</b> Determines whether or not the video stream from the video module is passed through the Color Space Converter (CSC).  0: Disable. The video stream is sent “as is” to the video mixer/blender. 1: Enable. The video stream is passed through the CSC (for YUV to RGB conversion).
9	HDSD	<b>High Definition/Standard Definition CSC.</b> Determines which algorithm to use for graphics color space conversion from RGB to YUV.  0: Standard Definition. 1: High Definition.

## VDE Bit Descriptions (Continued)

Bit	Name	Description
8	GFX_INS_VIDEO	<b>Graphics Window inside Video Window.</b> 0: Disable. The video window is assumed to be inside the graphics window. Outside the alpha window, graphics or video is displayed, depending on the result of color key comparison. 1: Enable. The graphics window is assumed to be inside the video window. Outside the alpha windows, video is displayed instead of graphics. Color key comparison is not performed outside the alpha window.
7	YUV_CSC_EN	<b>YUV Color Space Conversion Enable.</b> Enables YUV to YUV color space conversion on the video YUV input. HDS_D_VIDEO (bit 6) is used to determine which resolution the source video is. The video will be converted to the opposite resolution. If HDS_D_VIDEO = 0: YUV <sub>SD</sub> -> YUV <sub>HD</sub> If HDS_D_VIDEO = 1: YUV <sub>HD</sub> -> YUV <sub>SD</sub>
6	HDS_D_VIDEO	<b>High Definition/Standard Definition CSC on Video.</b> Determines what the source video resolution is for both YUV to RGB and YUV to YUV color space conversion algorithms. 0: Video source is in Standard Definition (Rec.ITU-R BT-601). 1: Video source is in High Definition (Rec.ITU-R BT-709).
5	RSVD (RO)	<b>Reserved (Read Only).</b> Reads back as 0.
4	SP	<b>Spare. Read/write, no function.</b>
3	RSVD (RO)	<b>Reserved (Read Only).</b> Reads back as 0.
2:0	SP	<b>Spares. Read/write, no function.</b>

## 6.8.3.19 Cursor Color Key (CCK)

VP Memory Offset 0A0h

Type R/W

Reset Value 00000000\_00000000h

## CCK Register Map

63	62	61	60	59	58	57	56	55	54	53	52	51	50	49	48	47	46	45	44	43	42	41	40	39	38	37	36	35	34	33	32	
RSVD																																
31	30	29	28	27	26	25	24	23	22	21	20	19	18	17	16	15	14	13	12	11	10	9	8	7	6	5	4	3	2	1	0	
RSVD		CCK_EN	COLOR_REG_OFFSET				CUR_COLOR_KEY																									

## CCK Bit Descriptions

Bit	Name	Description
63:30	RSVD (RO)	<b>Reserved (Read Only).</b> Reads back as 0.
29	CCK_EN	<b>Cursor Color Key Enable.</b> This bit enables the cursor color key matching function. 0: Disable. Graphics data will never match the cursor color key. 1: Enable. Graphics data is compared to the cursor color key.
28:24	COLOR_REG_OFFSET	<b>Cursor Color Register Offset.</b> This field indicates a bit in the incoming graphics stream that is used to indicate which of the two possible cursor color registers should be used for color key matches for the bits in the graphics stream.
23:0	CUR_COLOR_KEY	<b>Cursor Color Key.</b> Specifies the 24-bit RGB value of the cursor color key. The incoming graphics stream is compared with this value. If a match is detected, the pixel is replaced by a 24-bit value from one of the cursor color registers.

**6.8.3.20 Cursor Color Mask (CCM)**

VP Memory Offset 0A8h

Type R/W

Reset Value 00000000\_00000000h

**CCM Register Map**

63	62	61	60	59	58	57	56	55	54	53	52	51	50	49	48	47	46	45	44	43	42	41	40	39	38	37	36	35	34	33	32
RSVD																															
31	30	29	28	27	26	25	24	23	22	21	20	19	18	17	16	15	14	13	12	11	10	9	8	7	6	5	4	3	2	1	0
RSVD								CUR_COLOR_MASK																							

**CCM Bit Descriptions**

Bit	Name	Description
63:24	RSVD (RO)	<b>Reserved (Read Only).</b> Reads back as 0.
23:0	CUR_COLOR_MASK	<b>Cursor Color Mask.</b> This mask is a 24-bit value. Zeroes in the mask cause the corresponding bits in the incoming graphics stream to be forced to match. Example: A mask of FFFFFFFh causes all 24 bits to be compared (single color match). A mask of 000000h causes none of the 24 bits to be compared (all colors match).

**6.8.3.21 Cursor Color 1 (CC1)**

VP Memory Offset 0B0h

Type R/W

Reset Value 00000000\_00000000h

**CC1 Register Map**

63	62	61	60	59	58	57	56	55	54	53	52	51	50	49	48	47	46	45	44	43	42	41	40	39	38	37	36	35	34	33	32
RSVD																															
31	30	29	28	27	26	25	24	23	22	21	20	19	18	17	16	15	14	13	12	11	10	9	8	7	6	5	4	3	2	1	0
RSVD								CUR_COLOR_REG1																							

**CC1 Bit Descriptions**

Bit	Name	Description
63:24	RSVD (RO)	<b>Reserved (Read Only).</b> Reads back as 0.
23:0	CUR_COLOR_REG1	<b>Cursor Color Register 1.</b> Specifies a 24-bit cursor color value. This is an RGB value (for RGB blending). This is one of two possible cursor color values. Bits[28:24] of the Cursor Color Key register (VP Memory Offset 0A0h) determine a bit of the graphics data that if even, selects this color to be used.

**6.8.3.22 Cursor Color 2 (CC2)**

VP Memory Offset 0B8h

Type R/W

Reset Value 00000000\_00000000h

**CC2 Register Map**

63	62	61	60	59	58	57	56	55	54	53	52	51	50	49	48	47	46	45	44	43	42	41	40	39	38	37	36	35	34	33	32
RSVD																															
31	30	29	28	27	26	25	24	23	22	21	20	19	18	17	16	15	14	13	12	11	10	9	8	7	6	5	4	3	2	1	0
RSVD								CUR_COLOR_REG2																							

**CC2 Bit Descriptions**

Bit	Name	Description
63:24	RSVD (RO)	<b>Reserved (Read Only).</b> Reads back as 0.
23:0	CUR_COLOR_REG2	<b>Cursor Color Register 2.</b> Specifies a 24-bit cursor color value. This is an RGB value (for RGB blending).  This is one of two possible cursor color values. COLOR_REG_OFFSET (VP Memory Offset 0A0h[28:24] determine a bit of the graphics data that if odd, selects this color to be used.

**6.8.3.23 Alpha Window 1 X Position (A1X)**

VP Memory Offset 0C0h

Type R/W

Reset Value 00000000\_00000000h

**A1X Register Map**

63	62	61	60	59	58	57	56	55	54	53	52	51	50	49	48	47	46	45	44	43	42	41	40	39	38	37	36	35	34	33	32
RSVD																															
31	30	29	28	27	26	25	24	23	22	21	20	19	18	17	16	15	14	13	12	11	10	9	8	7	6	5	4	3	2	1	0
RSVD				ALPHA1_X_END												RSVD				ALPHA1_X_START											

**A1X Bit Descriptions**

Bit	Name	Description
63:28	RSVD (RO)	<b>Reserved (Read Only).</b> Reads back as 0.
27:16	ALPHA1_X_END	<b>Alpha Window 1 X End.</b> Indicates the horizontal end position of alpha window 1. This value is calculated according to the following formula: Value = Desired screen position + (H_TOTAL – H_SYNC_END) – 1. (Note 1)
15:12	RSVD (RO)	<b>Reserved (Read Only).</b> Reads back as 0.
11:0	ALPHA1_X_START	<b>Alpha Window 1 X Start.</b> Indicates the horizontal start position of alpha window 1. This value is calculated according to the following formula: Value = Desired screen position + (H_TOTAL – H_SYNC_END) – 2. (Note 1)

Note 1. H\_TOTAL and H\_SYNC\_END are values programmed in the Display Controller module registers. The value of (H\_TOTAL – H\_SYNC\_END) is sometimes referred to as “horizontal back porch.”

**6.8.3.24 Alpha Window 1 Y Position (A1Y)**

VP Memory Offset 0C8h

Type R/W

Reset Value 00000000\_00000000h

**A1Y Register Map**

63	62	61	60	59	58	57	56	55	54	53	52	51	50	49	48	47	46	45	44	43	42	41	40	39	38	37	36	35	34	33	32
RSVD																															
31	30	29	28	27	26	25	24	23	22	21	20	19	18	17	16	15	14	13	12	11	10	9	8	7	6	5	4	3	2	1	0
RSVD				ALPHA1_Y_END												RSVD				ALPHA1_Y_START											

**A1Y Bit Descriptions**

Bit	Name	Description
63:27	RSVD (RO)	<b>Reserved (Read Only).</b> Reads back as 0.
26:16	ALPHA1_Y_END	<b>Alpha Window 1 Y End.</b> Indicates the vertical end position of alpha window 1. This value is calculated according to the following formula: Value = Desired screen position + (V_TOTAL – V_SYNC_END) + 2. (Note 1)
15:11	RSVD (RO)	<b>Reserved (Read Only).</b> Reads back as 0.
10:0	ALPHA1_Y_START	<b>Alpha Window 1 Y Start.</b> Indicates the vertical start position of alpha window 1. This value is calculated according to the following formula: Value = Desired screen position + (V_TOTAL – V_SYNC_END) + 1. (Note 1)

Note 1. V\_TOTAL and V\_SYNC\_END are values programmed in the Display Controller module registers. The value of (V\_TOTAL – V\_SYNC\_END) is sometimes referred to as “vertical back porch.”

**6.8.3.25 Alpha Window 1 Color (A1C)**

VP Memory Offset 0D0h

Type R/W

Reset Value 00000000\_00000000h

**A1C Register Map**

63	62	61	60	59	58	57	56	55	54	53	52	51	50	49	48	47	46	45	44	43	42	41	40	39	38	37	36	35	34	33	32
RSVD																															
31	30	29	28	27	26	25	24	23	22	21	20	19	18	17	16	15	14	13	12	11	10	9	8	7	6	5	4	3	2	1	0
RSVD							ALPHA1_COLOR_REG_EN	ALPHA1_COLOR_REG																							

**A1C Bit Descriptions**

Bit	Name	Description
63:25	RSVD (RO)	<b>Reserved (Read Only).</b> Reads back as 0.
24	ALPHA1_COLOR_REG_EN	<p><b>Alpha Window 1 Color Register Enable.</b> Enable bit for the color key matching in alpha window 1.</p> <p>0: Disable. If this bit is disabled, the alpha window is enabled, and VG_CK = 0 (VP Memory Offset 008h[20]); then where there is a color key match within the alpha window, video is displayed.</p> <p>If this bit is disabled, the alpha window is enabled, and VG_CK = 1 (VP Memory Offset 008h[20]); then where there is a chroma-key match within the alpha window, graphics are displayed. See Figure 6-31 on page 438.</p> <p>1: Enable. If this bit is enabled and the alpha window is enabled, then where there is a color key match within the alpha window; the color value in ALPHA1_COLOR_REG (bits [23:0]) is displayed.</p>
23:0	ALPHA1_COLOR_REG	<p><b>Alpha Window 1 Color Register.</b> Specifies the color to be displayed inside the alpha window when there is a color key match in the alpha window.</p> <p>This color is only displayed if the alpha window is enabled and ALPHA1_COLOR_REG_EN (bit 24) is enabled.</p>

**6.8.3.26 Alpha Window 1 Control (A1T)**

VP Memory Offset 0D8h  
 Type R/W  
 Reset Value 00000000\_00000000h

**A1T Register Map**

63	62	61	60	59	58	57	56	55	54	53	52	51	50	49	48	47	46	45	44	43	42	41	40	39	38	37	36	35	34	33	32			
RSVD																																		
31	30	29	28	27	26	25	24	23	22	21	20	19	18	17	16	15	14	13	12	11	10	9	8	7	6	5	4	3	2	1	0			
RSVD													PPA1_EN	LOAD_ALPHA	ALPHA1_WIN_EN	ALPHA1_INC										ALPHA1_MUL								



## A1T Bit Descriptions

Bit	Name	Description
63:19	RSVD (RO)	<b>Reserved (Read Only).</b> Reads back as 0.
18	PPA1_EN	<b>Per-Pixel Alpha Window 1 Enable.</b> Enable per-pixel alpha functionality for alpha window 1. 0: Single alpha value for entire alpha window 1 (ALPHA1_MUL). 1: Each pixel has its own alpha value defined in the upper 8 bits of the graphics bus.
17	LOAD_ALPHA (WO)	<b>Load Alpha (Write Only).</b> When set to 1, this bit causes the Video Processor to load the alpha value (bits [31:24] of the video data path) multiplied with the alpha multiplier bits (ALPHA1_MUL, bits [7:0]) at the start of the next frame. This bit is cleared by the deassertion of VSYNC.
16	ALPHA1_WIN_EN	<b>Alpha Window 1 Enable.</b> Enable bit for alpha window 1. 0: Disable alpha window 1. 1: Enable alpha window 1.
15:8	ALPHA1_INC	<b>Alpha Window 1 Increment.</b> Specifies the alpha value increment/decrement. This is a signed 8-bit value that is added to the alpha value for each frame. The MSB (bit 15) indicates the sign (i.e., increment or decrement). When this value reaches either the maximum or the minimum alpha value (255 or 0), it keeps that value (i.e., it is not incremented/decremented) until it is reloaded via LOAD_ALPHA (bit 17).
7:0	ALPHA1_MUL	<b>Alpha Window 1 Value.</b> Specifies the alpha value to be used for this window.

## 6.8.3.27 Alpha Window 2 X Position (A2X)

VP Memory Offset 0E0h

Type R/W

Reset Value 00000000\_00000000h

## A2X Register Map

63	62	61	60	59	58	57	56	55	54	53	52	51	50	49	48	47	46	45	44	43	42	41	40	39	38	37	36	35	34	33	32
RSVD																															
31	30	29	28	27	26	25	24	23	22	21	20	19	18	17	16	15	14	13	12	11	10	9	8	7	6	5	4	3	2	1	0
RSVD				ALPHA2_X_END												RSVD				ALPHA2_X_START											

## A2X Bit Descriptions

Bit	Name	Description
63:28	RSVD (RO)	<b>Reserved (Read Only).</b> Reads back as 0.
27:16	ALPHA2_X_END	<b>Alpha Window 2 X End.</b> Indicates the horizontal end position of alpha window 2. This value is calculated according to the following formula: Value = Desired screen position + (H_TOTAL – H_SYNC_END) – 1. (Note 1)
15:12	RSVD (RO)	<b>Reserved (Read Only).</b> Reads back as 0.
11:0	ALPHA2_X_START	<b>Alpha Window 2 X Start.</b> Indicates the horizontal start position of alpha window 2. This value is calculated according to the following formula: Value = Desired screen position + (H_TOTAL – H_SYNC_END) – 2. (Note 1)

Note 1. H\_TOTAL and H\_SYNC\_END are values programmed in the Display Controller module registers. The value of (H\_TOTAL – H\_SYNC\_END) is sometimes referred to as “horizontal back porch.”

**6.8.3.28 Alpha Window 2 Y Position (A2Y)**

VP Memory Offset 0E8h  
 Type R/W  
 Reset Value 00000000\_00000000h

**A2Y Register Map**

63	62	61	60	59	58	57	56	55	54	53	52	51	50	49	48	47	46	45	44	43	42	41	40	39	38	37	36	35	34	33	32
RSVD																															
31	30	29	28	27	26	25	24	23	22	21	20	19	18	17	16	15	14	13	12	11	10	9	8	7	6	5	4	3	2	1	0
RSVD				ALPHA2_Y_END												RSVD				ALPHA2_Y_START											

**A2Y Bit Descriptions**

Bit	Name	Description
63:27	RSVD (RO)	<b>Reserved (Read Only).</b> Reads back as 0.
26:16	ALPHA2_Y_END	<b>Alpha Window 2 Y End.</b> Indicates the vertical end position of alpha window 2. This value is calculated according to the following formula: Value = desired screen position + (V_TOTAL – V_SYNC_END) + 2. (Note 1)
15:11	RSVD (RO)	<b>Reserved (Read Only).</b> Reads back as 0.
10:0	ALPHA2_Y_START	<b>Alpha Window 2 Y Start.</b> Indicates the vertical start position of alpha window 2. This value is calculated according to the following formula: Value = desired screen position + (V_TOTAL – V_SYNC_END) + 1. (Note 1)

Note 1. V\_TOTAL and V\_SYNC\_END are values programmed in the Display Controller module registers. The value of (V\_TOTAL – V\_SYNC\_END) is sometimes referred to as “vertical back porch.”

**6.8.3.29 Alpha Window 2 Color (AC2)**

VP Memory Offset 0F0h  
 Type R/W  
 Reset Value 00000000\_00000000h

**A2C Register Map**

63	62	61	60	59	58	57	56	55	54	53	52	51	50	49	48	47	46	45	44	43	42	41	40	39	38	37	36	35	34	33	32
RSVD																															
31	30	29	28	27	26	25	24	23	22	21	20	19	18	17	16	15	14	13	12	11	10	9	8	7	6	5	4	3	2	1	0
RSVD							ALPHA2_COLOR_REG_EN	ALPHA2_COLOR_REG																							

## A2C Bit Descriptions

Bit	Name	Description
63:25	RSVD (RO)	<b>Reserved (Read Only).</b> Reads back as 0.
24	ALPHA2_COLOR_REG_EN	<p><b>Alpha Window 2 Color Register Enable.</b> Enable bit for the color key matching in alpha window 2.</p> <p>0: Disable. If this bit is disabled, the alpha window is enabled, and VG_CK = 0 (VP Memory Offset 008h[20]); then where there is a color key match within the alpha window, video is displayed.</p> <p>If this bit is disabled, the alpha window is enabled, and VG_CK = 1 (VP Memory Offset 008h[20]); then where there is a chroma-key match within the alpha window, graphics are displayed. See Figure 6-31 on page 438.</p> <p>1: Enable. If this bit is enabled and the alpha window is enabled, then where there is a color key match within the alpha window; the color value in ALPHA2_COLOR_REG (bits [23:0]) is displayed.</p>
23:0	ALPHA2_COLOR_REG	<p><b>Alpha Window 2 Color Register.</b> Specifies the color to be displayed inside the alpha window when there is a color key match in the alpha window.</p> <p>This color is only displayed if the alpha window is enabled and ALPHA2_COLOR_REG_EN (bit 24) is enabled.</p>

## 6.8.3.30 Alpha Window 2 Control (A2T)

VP Memory Offset 0F8h

Type R/W

Reset Value 00000000\_00000000h

## A2T Register Map

63	62	61	60	59	58	57	56	55	54	53	52	51	50	49	48	47	46	45	44	43	42	41	40	39	38	37	36	35	34	33	32
RSVD																															
31	30	29	28	27	26	25	24	23	22	21	20	19	18	17	16	15	14	13	12	11	10	9	8	7	6	5	4	3	2	1	0
RSVD													PPA2_EN	LOAD_ALPHA	ALPHA2_WIN_EN	ALPHA2_INC								ALPHA2_MUL							

## A2T Bit Descriptions

Bit	Name	Description
63:19	RSVD (RO)	<b>Reserved (Read Only).</b> Reads back as 0.
18	PPA2_EN	<p><b>Per-Pixel Alpha Window 2 Enable.</b> Enable per-pixel alpha functionality for alpha window 2.</p> <p>0: Single alpha value for entire alpha window 2 (ALPHA2_MUL).</p> <p>1: Each pixel has its own alpha value defined in the upper 8 bits of the graphics bus.</p>
17	LOAD_ALPHA	<p><b>Load Alpha (Write Only).</b> When set to 1, this bit causes the Video Processor module to load the alpha value (bits [31:24] of the video data path) multiplied with the alpha multiplier (ALPHA2_MUL, bits [7:0]) at the start of the next frame. This bit is cleared by the deassertion of VSYNC.</p>

**A2T Bit Descriptions (Continued)**

Bit	Name	Description
16	ALPHA2_WIN_EN	<b>Alpha Window 2 Enable.</b> Enable bit for alpha window 2. 0: Disable alpha window 2. 1: Enable alpha window 2.
15:8	ALPHA2_INC	<b>Alpha Window 2 Increment.</b> Specifies the alpha value increment/decrement. This is a signed 8-bit value that is added to the alpha value for each frame. The MSB (bit 15) indicates the sign (i.e., increment or decrement). When this value reaches either the maximum or the minimum alpha value (255 or 0) it keeps that value (i.e., it is not incremented/decremented) until it is reloaded via LOAD_ALPHA (bit 17).
7:0	ALPHA2_MUL	<b>Alpha Window 2 Value.</b> Specifies the alpha value to be used for this window.

**6.8.3.31 Alpha Window 3 X Position (A3X)**

VP Memory Offset 100h

Type R/W

Reset Value 00000000\_00000000h

**A3X Register Map**

63	62	61	60	59	58	57	56	55	54	53	52	51	50	49	48	47	46	45	44	43	42	41	40	39	38	37	36	35	34	33	32
RSVD																															
31	30	29	28	27	26	25	24	23	22	21	20	19	18	17	16	15	14	13	12	11	10	9	8	7	6	5	4	3	2	1	0
RSVD				ALPHA3_X_END												RSVD				ALPHA3_X_START											

**A3X Bit Descriptions**

Bit	Name	Description
63:28	RSVD (RO)	<b>Reserved (Read Only).</b> Reads back as 0.
27:16	ALPHA3_X_END	<b>Alpha Window 3 X End.</b> Indicates the horizontal end position of alpha window 3. This value is calculated according to the following formula: Value = Desired screen position + (H_TOTAL – H_SYNC_END) – 1. (Note 1)
15:12	RSVD (RO)	<b>Reserved (Read Only).</b> Reads back as 0.
11:0	ALPHA3_X_START	<b>Alpha Window 3 X Start.</b> Indicates the horizontal start position of alpha window 3. This value is calculated according to the following formula: Value = Desired screen position + (H_TOTAL – H_SYNC_END) – 2. (Note 1)

Note 1. H\_TOTAL and H\_SYNC\_END are values programmed in the Display Controller module registers. The value of (H\_TOTAL – H\_SYNC\_END) is sometimes referred to as “horizontal back porch.”

**6.8.3.32 Alpha Window 3 Y Position (A3Y)**

VP Memory Offset 108h

Type R/W

Reset Value 00000000\_00000000h

**A3Y Register Map**

63	62	61	60	59	58	57	56	55	54	53	52	51	50	49	48	47	46	45	44	43	42	41	40	39	38	37	36	35	34	33	32
RSVD																															
31	30	29	28	27	26	25	24	23	22	21	20	19	18	17	16	15	14	13	12	11	10	9	8	7	6	5	4	3	2	1	0
RSVD				ALPHA3_Y_END												RSVD				ALPHA3_Y_START											

**A3Y Bit Descriptions**

Bit	Name	Description
63:27	RSVD (RO)	<b>Reserved (Read Only).</b> Reads back as 0.
26:16	ALPHA3_Y_END	<b>Alpha Window 3 Y End.</b> Indicates the vertical end position of alpha window 3. This value is calculated according to the following formula: Value = Desired screen position + (V_TOTAL – V_SYNC_END) + 2. (Note 1)
15:11	RSVD (RO)	<b>Reserved (Read Only).</b> Reads back as 0.
10:0	ALPHA3_Y_START	<b>Alpha Window 3 Y Start.</b> Indicates the vertical start position of alpha window 3. This value is calculated according to the following formula: Value = Desired screen position + (V_TOTAL – V_SYNC_END) + 1. (Note 1)

Note 1. V\_TOTAL and V\_SYNC\_END are values programmed in the Display Controller module.

The value of (V\_TOTAL – V\_SYNC\_END) is sometimes referred to as “vertical back porch.”

**6.8.3.33 Alpha Window 3 Color (A3C)**

VP Memory Offset 110h

Type R/W

Reset Value 00000000\_00000000h

**A3C Register Map**

63	62	61	60	59	58	57	56	55	54	53	52	51	50	49	48	47	46	45	44	43	42	41	40	39	38	37	36	35	34	33	32
RSVD																															
31	30	29	28	27	26	25	24	23	22	21	20	19	18	17	16	15	14	13	12	11	10	9	8	7	6	5	4	3	2	1	0
RSVD							ALPHA3_COLOR_REG_EN	ALPHA3_COLOR_REG																							

**A3C Bit Descriptions**

Bit	Name	Description
63:25	RSVD (RO)	<b>Reserved (Read Only).</b> Reads back as 0.
24	ALPHA3_COLOR_REG_EN	<p><b>Alpha Window 3 Color Register Enable.</b> Enable bit for the color key matching in alpha window 3.</p> <p>0: Disable. If this bit is disabled, the alpha window is enabled, and VG_CK = 0 (VP Memory Offset 008h[20]); then where there is a color key match within the alpha window, video is displayed.</p> <p>If this bit is disabled, the alpha window is enabled, and VG_CK = 1 (VP Memory Offset 008h[20]); then where there is a chroma-key match within the alpha window; graphics are displayed. See Figure 6-31 on page 438.</p> <p>1: Enable. If this bit is enabled and the alpha window is enabled, then where there is a color key match within the alpha window; the color value in ALHPA3_COLOR_REG (bits [23:0]) is displayed.</p>
23:0	ALPHA3_COLOR_REG	<p><b>Alpha Window 3 Color Register.</b> Specifies the color to be displayed inside the alpha window when there is a color key match in the alpha window.</p> <p>This color is only displayed if the alpha window is enabled and the ALPHA3_COLOR_REG_EN (bit 24) is enabled.</p>

**6.8.3.34 Alpha Window 3 Control (A3T)**

VP Memory Offset 118h  
 Type R/W  
 Reset Value 00000000\_00000000h

**A3T Register Map**

63	62	61	60	59	58	57	56	55	54	53	52	51	50	49	48	47	46	45	44	43	42	41	40	39	38	37	36	35	34	33	32
RSVD																															
31	30	29	28	27	26	25	24	23	22	21	20	19	18	17	16	15	14	13	12	11	10	9	8	7	6	5	4	3	2	1	0
RSVD													PPA3_EN	LOAD_ALPHA	ALPHA3_WIN_EN	ALPHA3_INC								ALPHA3_MUL							

**A3T Bit Descriptions**

Bit	Name	Description
63:19	RSVD (RO)	<b>Reserved (Read Only).</b> Reads back as 0.
18	PPA3_EN	<p><b>Per-Pixel Alpha Window 3 Enable.</b> Enable per-pixel alpha functionality for alpha window 3.</p> <p>0: Single alpha value for entire alpha window 3 (ALPHA3_MUL)                      1: Each pixel has its own alpha value defined in the upper 8 bits of the graphics bus.</p>
17	LOAD_ALPHA (WO)	<p><b>Load Alpha (Write Only).</b> When set to 1, this bit causes the video processor to load the alpha value (bits [31:24] of the video data path) multiplied with the alpha multiplier (ALPHA3_MUL, bits [7:0]) at the start of the next frame. This bit is cleared by the de-assertion of VSYNC.</p>

## A3T Bit Descriptions (Continued)

Bit	Name	Description
16	ALPHA3_WIN_EN	<b>Alpha Window 3 Enable.</b> Enable bit for alpha window 3. 0: Disable alpha window 3. 1: Enable alpha window 3.
15:8	ALPHA3_INC	<b>Alpha Window 3 Increment.</b> Specifies the alpha value increment/decrement. This is a signed 8-bit value that is added to the alpha value for each frame. The MSB (bit 15) indicates the sign (i.e., increment or decrement). When this value reaches either the maximum or the minimum alpha value (255 or 0) it keeps that value (i.e., it is not incremented/decremented) until it is reloaded via LOAD_ALPHA (bit 17).
7:0	ALPHA3_MUL	<b>Alpha Window 3 Value.</b> Specifies the alpha value to be used for this window.

## 6.8.3.35 Video Request (VRR)

VP Memory Offset 120h

Type R/W

Reset Value 00000000\_001B0017h

## VRR Register Map

63	62	61	60	59	58	57	56	55	54	53	52	51	50	49	48	47	46	45	44	43	42	41	40	39	38	37	36	35	34	33	32
RSVD																															
31	30	29	28	27	26	25	24	23	22	21	20	19	18	17	16	15	14	13	12	11	10	9	8	7	6	5	4	3	2	1	0
RSVD				XRQ												RSVD				YRQ											

## VRR Bit Descriptions

Bit	Name	Description
63:28	RSVD (RO)	<b>Reserved (Read Only).</b> Reads back as 0.
27:16	XRQ	<b>Video X Request.</b> Indicates the horizontal (pixel) location to start requesting video data from.
15:11	RSVD (RO)	<b>Reserved (Read Only).</b> Reads back as 0.
10:0	YRQ	<b>Video Y Request.</b> Indicates the line number to start requesting video data from.

**6.8.3.36 Alpha Watch (AWT)**

VP Memory Offset 128h

Type RO

Reset Value 00000000\_00000000h

Alpha values may be automatically incremented/decremented for successive frames. This register can be used to read alpha values that are being used in the current frame.

**AWT Register Map**

63	62	61	60	59	58	57	56	55	54	53	52	51	50	49	48	47	46	45	44	43	42	41	40	39	38	37	36	35	34	33	32
RSVD																															
31	30	29	28	27	26	25	24	23	22	21	20	19	18	17	16	15	14	13	12	11	10	9	8	7	6	5	4	3	2	1	0
RSVD								AW3								AW2								AW1							

**AWT Bit Descriptions**

Bit	Name	Description
63:24	RSVD	<b>Reserved.</b> Reads back as 0.
23:16	AW3	<b>Alpha Value for Window 3.</b>
15:8	AW2	<b>Alpha Value for Window 2.</b>
7:0	AW1	<b>Alpha Value for Window 1.</b>

**6.8.3.37 Video Processor Test Mode (VTM)**

VP Memory Offset 130h

Type R/W

Reset Value 00000000\_00000000h

**VTM Register Map**

63	62	61	60	59	58	57	56	55	54	53	52	51	50	49	48	47	46	45	44	43	42	41	40	39	38	37	36	35	34	33	32
RSVD																															
31	30	29	28	27	26	25	24	23	22	21	20	19	18	17	16	15	14	13	12	11	10	9	8	7	6	5	4	3	2	1	0
SP	RSVD																				SP	RSVD	RSVD	RSVD							

**VTM Bit Descriptions**

Bit	Name	Description
63:32	RSVD (RO)	<b>Reserved (Read Only).</b> Reads back as 0.
31	SP	<b>Spare.</b> Read/write; no function.
30:11	RSVD (RO)	<b>Reserved (Read Only).</b> Reads back as 0.
10:9	SP	<b>Spares.</b> Read/write; no function.
8:7	RSVD (RO)	<b>Reserved (Read Only).</b> Reads back as 0.
6	RSVD	<b>Reserved.</b> Reserved for test purposes.
5:4	RSVD (RO)	<b>Reserved (Read Only).</b> Reads back as 0.
3:0	RSVD	<b>Reserved.</b> Reserved for test purposes.



**6.8.3.38 Even Video Y Position (VYE)**

VP Memory Offset 138h

Type R/W

Reset Value 00000000\_00000000h

**VYE Register Map**

63	62	61	60	59	58	57	56	55	54	53	52	51	50	49	48	47	46	45	44	43	42	41	40	39	38	37	36	35	34	33	32
RSVD																															
31	30	29	28	27	26	25	24	23	22	21	20	19	18	17	16	15	14	13	12	11	10	9	8	7	6	5	4	3	2	1	0
RSVD				VID_Y_END												RSVD				VID_Y_START											

**VYE Bit Descriptions**

Bit	Name	Description
63:27	RSVD (RO)	<b>Reserved (Read Only).</b> Reads back as 0.
26:16	VID_Y_END	<b>Video Y End Position.</b> Represents the vertical end position of the video window. This value is calculated according to the following formula: Value = Desired screen position + (V_TOTAL – V_SYNC_END) + 2. (Note 1)
15:11	RSVD (RO)	<b>Reserved (Read Only).</b> Reads back as 0.
10:0	VID_Y_START	<b>Video Y Start Position.</b> Represents the vertical start position of the video window. This register is programmed relative to CRT Vertical sync input (not the physical screen position). This value is calculated according to the following formula: Value = Desired screen position + (V_TOTAL – V_SYNC_END) + 1. (Note 1)

Note 1. V\_TOTAL and V\_SYNC\_END are the values written in the Display Controller module registers.

**6.8.3.39 Even Alpha Window 1 Y Position (A1YE)**

VP Memory Offset 140h

Type R/W

Reset Value 00000000\_00000000h

**A1YE Register Map**

63	62	61	60	59	58	57	56	55	54	53	52	51	50	49	48	47	46	45	44	43	42	41	40	39	38	37	36	35	34	33	32
RSVD																															
31	30	29	28	27	26	25	24	23	22	21	20	19	18	17	16	15	14	13	12	11	10	9	8	7	6	5	4	3	2	1	0
RSVD				ALPHA1_Y_END												RSVD				ALPHA1_Y_START											

**A1YE Bit Descriptions**

Bit	Name	Description
63:27	RSVD (RO)	<b>Reserved (Read Only).</b> Reads back as 0.
26:16	ALPHA1_Y_END	<b>Alpha Window 1 Y End.</b> Indicates the vertical end position of alpha window 1. This value is calculated according to the following formula: Value = Desired screen position + (V_TOTAL – V_SYNC_END) + 2. (Note 1)
15:11	RSVD (RO)	<b>Reserved (Read Only).</b> Reads back as 0.
10:0	ALPHA1_Y_START	<b>Alpha Window 1 Y Start.</b> Indicates the vertical start position of alpha window 1. This value is calculated according to the following formula: Value = Desired screen position + (V_TOTAL – V_SYNC_END) + 1. (Note 1)

Note 1. V\_TOTAL and V\_SYNC\_END are values programmed in the Display Controller module registers. The value of (V\_TOTAL – V\_SYNC\_END) is sometimes referred to as “vertical back porch”.

**6.8.3.40 Even Alpha Window 2 Y Position (A2YE)**

VP Memory Offset 148h

Type R/W

Reset Value 00000000\_00000000h

**A2YE Register Map**

63	62	61	60	59	58	57	56	55	54	53	52	51	50	49	48	47	46	45	44	43	42	41	40	39	38	37	36	35	34	33	32
RSVD																															
31	30	29	28	27	26	25	24	23	22	21	20	19	18	17	16	15	14	13	12	11	10	9	8	7	6	5	4	3	2	1	0
RSVD				ALPHA2_Y_END												RSVD				ALPHA2_Y_START											

**A2YE Bit Descriptions**

Bit	Name	Description
63:27	RSVD (RO)	<b>Reserved (Read Only).</b> Reads back as 0.
26:16	ALPHA2_Y_END	<b>Alpha Window 2 Y End.</b> Indicates the vertical end position of alpha window 2. This value is calculated according to the following formula: Value = Desired screen position + (V_TOTAL – V_SYNC_END) + 2. (Note 1)
15:11	RSVD (RO)	<b>Reserved (Read Only).</b> Reads back as 0.
10:0	ALPHA2_Y_START	<b>Alpha Window 2 Y Start.</b> Indicates the vertical start position of alpha window 2. This value is calculated according to the following formula: Value = Desired screen position + (V_TOTAL – V_SYNC_END) + 1. (Note 1)

Note 1. V\_TOTAL and V\_SYNC\_END are values programmed in the Display Controller module registers. The value of (V\_TOTAL – V\_SYNC\_END) is sometimes referred to as “vertical back porch”.

**6.8.3.41 Even Alpha Window 3 Y Position (A3YE)**

VP Memory Offset 150h

Type R/W

Reset Value 00000000\_00000000h

**A3YE Register Map**

63	62	61	60	59	58	57	56	55	54	53	52	51	50	49	48	47	46	45	44	43	42	41	40	39	38	37	36	35	34	33	32
RSVD																															
31	30	29	28	27	26	25	24	23	22	21	20	19	18	17	16	15	14	13	12	11	10	9	8	7	6	5	4	3	2	1	0
RSVD				ALPHA3_Y_END												RSVD				ALPHA3_Y_START											

**A3YE Bit Descriptions**

Bit	Name	Description
63:27	RSVD (RO)	<b>Reserved (Read Only).</b> Reads back as 0.
26:16	ALPHA3_Y_END	<b>Alpha Window 3 Y End.</b> Indicates the vertical end position of alpha window 3. This value is calculated according to the following formula: Value = Desired screen position + (V_TOTAL – V_SYNC_END) + 2. (Note 1)
15:11	RSVD (RO)	<b>Reserved (Read Only).</b> Reads back as 0.
10:0	ALPHA3_Y_START	<b>Alpha Window 3 Y Start.</b> Indicates the vertical start position of alpha window 3. This value is calculated according to the following formula: Value = Desired screen position + (V_TOTAL – V_SYNC_END) + 1. (Note 1)

Note 1. V\_TOTAL and V\_SYNC\_END are values programmed in the Display Controller module registers. The value of (V\_TOTAL – V\_SYNC\_END) is sometimes referred to as “vertical back porch”.

**6.8.3.42 Video Coefficient RAM (VCR)**

VP Memory Offset 1000h-1FFFh

Type R/W

Reset Value xxxxxxxx\_xxxxxxxh

**VCR Register Map**

63	62	61	60	59	58	57	56	55	54	53	52	51	50	49	48	47	46	45	44	43	42	41	40	39	38	37	36	35	34	33	32
VC3																VC2															
31	30	29	28	27	26	25	24	23	22	21	20	19	18	17	16	15	14	13	12	11	10	9	8	7	6	5	4	3	2	1	0
VC1																VC0															

**VCR Bit Descriptions**

Bit	Name	Description
63:48	VC3	<b>Coefficient 3.</b> Coefficient for tap 3 of filter.
47:32	VC2	<b>Coefficient 2.</b> Coefficient for tap 2 of filter.
31:16	VC1	<b>Coefficient 1.</b> Coefficient for tap 1 of filter.
15:0	VC0	<b>Coefficient 0.</b> Coefficient for tap 0 of filter.

**6.8.3.43 Panel Timing Register 1 (PT1)**

VP Memory Offset 400h

Type R/W

Reset Value 00000000\_00000000h

**PT1 Register Map**

63	62	61	60	59	58	57	56	55	54	53	52	51	50	49	48	47	46	45	44	43	42	41	40	39	38	37	36	35	34	33	32
RSVD																															
31	30	29	28	27	26	25	24	23	22	21	20	19	18	17	16	15	14	13	12	11	10	9	8	7	6	5	4	3	2	1	0
RSVD	FP_VSYNC_POL	FP_HSYNC_POL	RSVD	HSYNC_SRC	RSVD																		HSYNC_DELAY	HSYNC_PLS_WIDTH							

**PT1 Bit Descriptions**

Bit	Name	Description
63:32	RSVD (RO)	<b>Reserved (Read Only).</b> Reads back as 0.
31	RSVD	<b>Reserved.</b> This bit is not defined.
30	FP_VSYNC_POL	<b>FP_VSYNC Input Polarity.</b> Selects positive or negative polarity of the FP_VSYNC input. Program this bit to match the polarity of the incoming FP_VSYNC signal. Note that FP Memory Offset 408h[23] controls the polarity of the output VSYNC. 0: FP_VSYNC is normally low, transitioning high during sync interval. (Default) 1: FP_VSYNC is normally high, transitioning low during sync interval

## PT1 Bit Descriptions (Continued)

Bit	Name	Description
29	FP_HSYNC_POL	<b>FP_HSYNC Input Polarity.</b> Selects positive or negative polarity of the FP_HSYNC input. Program this bit to match the polarity of the incoming FP_HSYNC signal. Note that FP Memory Offset 408h[22] controls the polarity of the output HSYNC. 0: FP_HSYNC is normally low, transitioning high during sync interval. (Default) 1: FP_HSYNC is normally high, transitioning low during sync interval
28	RSVD	<b>Reserved.</b> This bit is not defined.
27	HSYNC_SRC	<b>TFT Horizontal Sync Source.</b> Selects a delayed or undelayed TFT horizontal sync output. This bit determines whether to use the HSYNC for the TFT panel without delaying the input HSYNC, or delay the HSYNC before sending it on to TFT. HSYNC_DELAY (bits [7:5]) determine the amount of the delay. 0: Do not delay the input HSYNC before it is output onto the LP/HSYNC. (Default) 1: Delay the input HSYNC before it is output onto the LP/HSYNC
26:8	RSVD	<b>Reserved.</b> R/W; no function.
7:5	HSYNC_DELAY	<b>Horizontal Sync Delay.</b> Selects the amount of delay in the output HSYNC pulse with respect to the input HSYNC pulse. The delay is programmable in steps of one DOTCLK. SYNC_SRC (bit 27) must be set in order for HSYNC_DELAY to be recognized. HSYNC_DELAY is only used for TFT modes. 000: No delay from the input HSYNC. (Default) 001-111: Delay the HSYNC start by one to seven DOTCLKs.
4:0	HSYNC_PLS_WIDTH	<b>Horizontal Sync Pulse Width.</b> Stretch the HSYNC pulse width by up to 31 DOTCLKs. The pulse width is programmable in steps of one DOTCLK. HSYNC_PLS_WIDTH is only used for TFT modes. 00000: Does not generate the HSYNC pulse. The TFT panel uses the default input timing, which is selected by keeping the HSYNC_SRC bit (bit 27) set to 0. (Default) 00001-11111: The HSYNC pulse width can be varied from one to 31 DOTCLKs.

**6.8.3.44 Panel Timing Register 2 (PT2)**

VP Memory Offset 408h

Type R/W

Reset Value 00000000\_00000000h

**PT2 Register Map**

63	62	61	60	59	58	57	56	55	54	53	52	51	50	49	48	47	46	45	44	43	42	41	40	39	38	37	36	35	34	33	32	
RSVD																																
31	30	29	28	27	26	25	24	23	22	21	20	19	18	17	16	15	14	13	12	11	10	9	8	7	6	5	4	3	2	1	0	
SP	TFT_PASS_THRU	LPOL	RSVD	SCRC	RSVD			VSP	HSP	RSVD			MCS	PIXF			RSVD															

**PT2 Bit Descriptions**

Bit	Name	Description
63:32	RSVD (RO)	<b>Reserved (Read Only).</b> Reads back as 0.
31	SP	<b>Spare.</b> Bit is read/write, but has no function.
30	TFT_PASS_THRU	<b>TFT Pass Through.</b> Activates the TFT Pass Through mode. In TFT Pass Through mode, the input timing and the pixel data is passed directly on to the panel interface timing and the panel data pins to drive the TFT panel. In Pass Through mode the internal FP TFT logic and timing is not used.  0: Normal mode; uses the TFT logic and timing from the FP. 1: TFT Pass Through mode; FP TFT timing logic functions are not used.
29	LPOL	<b>Display Timing Strobe Polarity Select.</b> Selects the polarity of the LDE/MOD pin. This can be used for panels that require an active low timing LDE interface signal.  0: LDE/MOD signal is active high. (Default) 1: LDE/MOD signal is active low
28	RSVD	<b>Reserved.</b> This bit is not defined.
27	SCRC	<b>Panel Shift Clock Retrace Activity Control.</b> Programs the shift clock (SHFCLK) to be either free running, or active only during the display period. Some TFT panels recommend keeping the shift clock running during the retrace time.  0: Shift clock is active only during active display period. 1: Shift clock is free running during the entire frame period.
26:24	RSVD	<b>Reserved.</b> These bits are not defined.
23	VSP	<b>Vertical Sync Output Polarity.</b> Selects polarity of the output VSYNC signal. Note that VP Memory Offset 400h[30] selects the polarity of the input VSYNC.  0: VSYNC output is active high. 1: VSYNC output is active low
22	HSP	<b>Horizontal Sync Output Polarity.</b> Selects polarity of output HSYNC signal. Note that VP Memory Offset 400h[29] selects the polarity of the input HSYNC, and this bit controls the output polarity.  0: HSYNC output is active high. 1: HSYNC output is active low
21:20	RSVD	<b>Reserved.</b> These bits are not defined.

**PT2 Bit Descriptions (Continued)**

Bit	Name	Description
19	MCS	<b>Color/Mono Select.</b> Selects color or monochrome LCD panel. 0: Color. 1: Monochrome.
18:16	PIXF	<b>Pixel Output Format.</b> These bits define the pixel output format. The selection of the pixel output format determines how the pixel data is formatted before being sent on to the DRGB pins. These settings also determine the SHFCLK frequency for the specific panel. 000: Up to 24-bit TFT panel with one pixel per clock. SHFCLK = DOTCLK. 001: 18/24-bit TFT XGA panel with two pixels per clock. SHFCLK = 1/2 of DOTCLK. 010, 011, 100, 101, 110, and 111: Reserved.
15:0	RSVD	<b>Reserved.</b> These bits are not defined.

**6.8.3.45 Power Management (PM)**

FP Memory Offset 410h  
 Type R/W  
 Reset Value 00000000\_00000002h

**PM Register Map**

63	62	61	60	59	58	57	56	55	54	53	52	51	50	49	48	47	46	45	44	43	42	41	40	39	38	37	36	35	34	33	32
RSVD																															
31	30	29	28	27	26	25	24	23	22	21	20	19	18	17	16	15	14	13	12	11	10	9	8	7	6	5	4	3	2	1	0
SP				PWR_SEQ_SEL	PNL_PWR_SIM	D	P	PUB2	PUB1	PUB0	PD2	PD1	PD0	HDEL	VDEL	SP											SINV	PANEL_PWR_UP	PANEL_PWR_DOWN	PANEL_OFF	PANEL_ON

**PM Bit Descriptions**

Bit	Name	Description
63:32	RSVD (RO)	<b>Reserved (Read Only).</b> Reads back as 0.
31:28	SP	<b>Spares.</b> Read/write; no function.
27	PWR_SEQ_SEL	<b>Power Sequence Select.</b> Selects whether to use internal or external power sequence. The power sequence controls the order in which VDDEN, the data and control signals, and the backlight control signal DISPEN become active during power up, and inactive during power down. 0: Use internal power sequencing (timing is controlled by bits [24:18]). 1: Use external power sequencing. Must be written to 0.
26	PNL_PWR_SIM	<b>Panel Power Sequence Test Mode.</b> This bit should always be set to 0. For simulating the model of the panel power sequence logic, this bit may be set to 1. It connects the 14 MHz reference clock to the 32 Hz panel power sequence clock for faster simulations. The hardware will not function properly if this bit is set to 1.

## PM Bit Descriptions (Continued)

Bit	Name	Description
25	D	<b>Display Off Control Source.</b> Selects how DISPEN is controlled. Independent control may be used to disable the backlight to save power even if the panel is otherwise ON. 0: DISPEN is controlled by with the power up/down sequence. 1: DISPEN is controlled independently of the power sequence.
24	P	<b>Panel Power On.</b> Selects whether the panel is powered down or up following the power sequence mechanism. 0: Power down. 1: Power up.
23	PUB2	<b>Panel Power Up Phase Bit 2.</b> Selects the amount of time from when V <sub>CORE</sub> is enabled to when the panel data signals are enabled. 0: 32 ms 1: 128 ms
22	PUB1	<b>Panel Power Up Phase Bit 1.</b> Selects the time amount of from when the panel data signals are enabled to PUB0. 0: 32 ms. 1: 128 ms.
21	PUB0	<b>Panel Power Up Phase Bit 0.</b> Selects the amount of time from PUB1 to when DISPEN is enabled. 0: 32 ms. 1: 128 ms.
20	PD2	<b>Panel Power Down Phase Bit 2.</b> Selects the amount of time from when panel DISPEN is disabled to PD1. 0: 32 ms. 1: 128 ms.
19	PD1	<b>Panel Power Down Phase Bit 1.</b> Selects the amount of time from PD2 to when the panel data signals are disabled. 0: 32 ms. 1: 128 ms.
18	PD0	<b>Panel Power Down Phase Bit 0.</b> Selects the amount of time from when the panel data signals are disabled to when panel V <sub>CORE</sub> is disabled. 0: 32 ms. 1: 128 ms.
17:16	HDEL	<b>HSYNC Delay.</b> Delays HSYNC 0 - 3 Dot clocks.
15:14	VDEL	<b>VSYNC Delay.</b> Delays VSYNC 0 - 3 Dot clocks.
13	SINV	<b>SHFCLK Invert.</b> Invert SHFCLK to panel.
12:4	SP	<b>Spares.</b> Read/write; no function.
3	PANEL_PWR_UP (RO)	<b>Panel Power-Up Status (Read Only).</b> A 1 indicates the flat panel is currently powering up.
2	PANEL_PWR_DOWN (RO)	<b>Panel Power-Down Status (Read Only).</b> A 1 indicates the flat panel is currently powering down.
1	PANEL_OFF (RO)	<b>Panel OFF Status (Read Only).</b> A 1 indicates the flat panel is currently fully off.
0	PANEL_ON (RO)	<b>Panel ON Status (Read Only).</b> A 1 indicates the flat panel is currently fully on.

**6.8.3.46 Dither and Frame Rate Control (DFC)**

VP Memory Offset 418h  
 Type R/W  
 Reset Value 00000000\_00000000h

**DFC Register Map**

63	62	61	60	59	58	57	56	55	54	53	52	51	50	49	48	47	46	45	44	43	42	41	40	39	38	37	36	35	34	33	32
RSVD																															
31	30	29	28	27	26	25	24	23	22	21	20	19	18	17	16	15	14	13	12	11	10	9	8	7	6	5	4	3	2	1	0
RSVD																		RRS	RSVD	RVRS	RSVD				BC		DBS			DENB	

**DFC Bit Descriptions**

Bit	Name	Description
63:13	RSVD (RO)	<b>Reserved (Read Only).</b> Reads back as 0.
12	RRS	<b>RAM or ROM Select.</b> This bit selects either internal ROM or internal RAM as the source of the dither patterns.  0: Selects fixed (internal to FP) ROM for dither patterns. (Default) 1: Selects programmable (internal to FP) RAM for dither patterns.  To update the dither RAM, this bit must = 1. See FP Memory Offset 448h[6].
11	RSVD (RO)	<b>Reserved (Read Only).</b> Reads back as 0.
10	RVRS	<b>Negative Image.</b> This converts the black to white and white to black and all colors in between to their logical inverse to provide a negative image of the original image. It acts as though the incoming data stream were logically inverted (1 becomes 0 and 0 becomes 1).  0: Normal display mode. 1: Negative image display mode.
9:7	RSVD (RO)	<b>Reserved (Read Only).</b> Reads back as 0.
6:4	BC	<b>Base Color.</b> This field is used in conjunction with the DBS field (bits [3:1]). The value in bits [6:4] sets the base color used prior to dithering.  000: Select 1 MSB for base color use prior to dithering. 001: Select 2 MSB for base color use prior to dithering. 010: Select 3 MSB for base color use prior to dithering. 011: Select 4 MSB for base color use prior to dithering. 100: Select 5 MSB for base color use prior to dithering. 101: Select 6 MSB for base color use prior to dithering. 110: Select 7 MSB for base color use prior to dithering. 111: Select 8 MSB for base color, no dithering.
3:1	DBS	<b>Dithering Bits Select.</b> This field is used to select the number of bits to be used for the dithering pattern. Dither bits are the LSBs of each pixel's final color value; FRM bits are the MSBs.  000: Selects 6 bits as dither bits. 001: Selects 5 bits as dither bits. 010: Selects 4 bits as dither bits. 011: Selects 3 bits as dither bits. 100: Selects 2 bits as dither bits. 101: Selects 1 bits as dither bits. 110, 111: Reserved.



## DFC Bit Descriptions (Continued)

Bit	Name	Description
0	DENB	<p><b>Dithering Enable.</b> Enable/disable dithering. The dither bit must be enabled in order for dither RAM reads or writes to occur. When this bit is cleared, the internal dither RAM is powered down, which saves power.</p> <p>0: Dither disable. The dithering function is turned off. When the dither is disabled the Dithering Bits Select (bits [3:1]) do not have any effect and the dither RAM is not accessible.</p> <p>1: Dither enable. The dither functions with the number of dither bits as set in the Dithering Bits Select (bits [3:1]).</p>

## 6.8.3.47 Dither RAM Control and Address (DCA)

VP Memory Offset 448h

Type R/W

Reset Value 00000000\_00000000h

## DCA Register Map

63	62	61	60	59	58	57	56	55	54	53	52	51	50	49	48	47	46	45	44	43	42	41	40	39	38	37	36	35	34	33	32
RSVD																															
31	30	29	28	27	26	25	24	23	22	21	20	19	18	17	16	15	14	13	12	11	10	9	8	7	6	5	4	3	2	1	0
RSVD																							A	U	ADDR						

## DCA Bit Descriptions

Bit	Name	Description
63:8	RSVD (RO)	<b>Reserved (Read Only).</b> Reads back as 0.
7	A	<p><b>Dither RAM Access Bit.</b> Allows reads and writes to/from Dither RAM.</p> <p>0: Disable (do not allow reads or writes).</p> <p>1: Enable (allow reads and writes).</p> <p>To perform dither RAM writes and reads, both bits 7 and 6 must be set to 1. In addition VP Memory Offset 418h bits 12 and 0 must both be set to 1. If any of these bits are not set to 1, the RAM goes into power-down mode.</p>
6	U	<p><b>Dither RAM Update.</b> This bit works in conjunction with bit 7. If this bit is enabled, it allows the data to update the RAM.</p> <p>0: Disable (do not allow dither RAM accesses).</p> <p>1: Enable (allow dither RAM accesses).</p> <p>To perform dither RAM writes and reads, both bits 7 and 6 must be set to 1. In addition VP Memory Offset 418h bits 12 and 0 must both be set to 1. If any of these bits are not set to 1, the RAM goes into power-down mode.</p>
5:0	ADDR	<b>RAM Address.</b> This 6-bit field specifies the address to be used for the next access to the dither RAM.

**6.8.3.48 Dither Memory Data (DMD)**

VP Memory Offset 450h

Type R/W

Reset Value 00000000\_00000000h

**DMD Register Map**

63	62	61	60	59	58	57	56	55	54	53	52	51	50	49	48	47	46	45	44	43	42	41	40	39	38	37	36	35	34	33	32
RSVD																															
31	30	29	28	27	26	25	24	23	22	21	20	19	18	17	16	15	14	13	12	11	10	9	8	7	6	5	4	3	2	1	0
RDAT																															

**DMD Bit Descriptions**

Bit	Name	Description
63:32	RSVD (RO)	<b>Reserved (Read Only).</b> Reads back as 0.
31:0	RDAT	<b>RAM Data.</b> This 32-bit field contains the read or write data for the RAM access.

**6.8.3.49 Panel CRC Signature (CRC)**

VP Memory Offset 458h

Type R/W

Reset Value 00000000\_00000000h

**CRC Register Map**

63	62	61	60	59	58	57	56	55	54	53	52	51	50	49	48	47	46	45	44	43	42	41	40	39	38	37	36	35	34	33	32
RSVD																															
31	30	29	28	27	26	25	24	23	22	21	20	19	18	17	16	15	14	13	12	11	10	9	8	7	6	5	4	3	2	1	0
RSVD																							FRCT			SIGVAL	SIGFR	SIGEN			

**CRC Bit Descriptions**

Bit	Name	Description
63:9	RSVD (RO)	<b>Reserved (Read Only).</b> Reads back as 0.
8:3	FRCT (RO)	<b>Frame Count (Read Only).</b> Represents the frame count, which is an index for the generated signature for that frame.
2	SIGVAL (RO)	<b>Signature Valid (Read Only).</b> If this bit is set, the signature operation has completed and the signature may be safely read from the 32-Bit Panel CRC Register (VSP Memory Offset 468h).
1	SIGFR	<b>Signature Free Run.</b> If this bit is high, with signature enabled (bit 0 = 1), the signature generator captures data continuously across multiple frames. This bit may be set high when the signature is started, then later set low, which causes the signature generation process to stop at the end of the current frame. 0: Capture signature for only one frame. 1: Free run across multiple frames.
0	SIGEN	<b>Signature Enable.</b> Enables/disables signature capture. 1: Enable signature capture. 0: Disable signature capture.

**6.8.3.50 32-Bit Panel CRC (CRC32)**

VP Memory Offset 468h

Type RO

Reset Value 00000000\_00000001h

**CRC32 Register Map**

63	62	61	60	59	58	57	56	55	54	53	52	51	50	49	48	47	46	45	44	43	42	41	40	39	38	37	36	35	34	33	32
RSVD																															
31	30	29	28	27	26	25	24	23	22	21	20	19	18	17	16	15	14	13	12	11	10	9	8	7	6	5	4	3	2	1	0
CRC																															

**CRC32 Bit Descriptions**

Bit	Name	Description
63:32	RSVD	<b>Reserved.</b> Reads back as 0.
31:0	CRC	<b>32-Bit CRC.</b> 32-Bit Signature when in 32-bit CRC mode. See FP Memory Offset 458h for additional information.

**6.8.3.51 Video Output Port Configuration (VOP\_CONFIG)**

VP Memory Offset 800h

Type R/W

Reset Value 00000000\_00000000h

**VOP\_CONFIG Register Map**

63	62	61	60	59	58	57	56	55	54	53	52	51	50	49	48	47	46	45	44	43	42	41	40	39	38	37	36	35	34	33	32
RSVD																															
31	30	29	28	27	26	25	24	23	22	21	20	19	18	17	16	15	14	13	12	11	10	9	8	7	6	5	4	3	2	1	0
SPARE							VBI_SWAP	RSVD	RGB_MODE	VALID_SIG	INV_DE_POL	INV_VS_POL	INV_HS_POL	UV_SWAP	VSYNC_SHFT	DIS_DEC	601_MODE	VBI	RSVD	TASK	SGFR	SIGE	SC120X_MODE	422_MODE	EXT_VIP_CODES	VIP_LEVEL	VIP_MODE				

**VOP\_CONFIG Bit Descriptions**

Bit	Name	Description
63:32	RSVD (RO)	<b>Reserved (Read Only).</b> Reads back as 0.
31:25	SPARE	<b>Spare.</b>
24	VBI SWAP	<b>VBI Swap.</b> When set to 1, swap upper and lower bytes of VBI data.
22:23	RSVD	<b>Reserved.</b>
21	RGB MODE	<b>RGB Mode.</b> Set this bit to 1 if RGB data sent: applicable in 24-bit 601 mode so as to choose correct blanking data. If this bit is set, then blanking data is 0, otherwise it is YUV = 10, 80, 80.
20	VALID SIG (RO)	<b>Valid Signature (Read Only).</b> If signature enabled, this bit can be read to determine if the signature is valid.
19	INV DE POL	<b>Invert Display Enable Polarity.</b> Set to 1 to invert polarity of display enable (for 601 mode only).

## VOP\_CONFIG Bit Descriptions (Continued)

Bit	Name	Description
18	INV VS POL	<b>Invert VSYNC Polarity.</b> Set to 1 to invert polarity of VSYNC (for 601 mode only).
17	INV HS POL	<b>Invert HSYNC Polarity.</b> Set to 1 to invert polarity of HSYNC (for 601 mode only).
16	UV SWAP	<b>UV Swap.</b> 0: No swap. 1: Swap lowest byte with next lowest byte in [23:0] input data stream. This is essentially swapping the U and V, and if in RGB, swapping G and B.
15:14	VSYNC SHFT	<b>VSYNC Shift.</b> This is the number of VOP clocks to shift the VSYNC with respect to HSYNC for odd field detection in 601 mode. 00: Shift VSYNC earlier by 4 cycles (-4). 01: Shift VSYNC earlier by 2 cycles (-2). 10: Zero shift - both are aligned as they were received from Display Controller. 11: Shift later based on programmable value in DC Memory Offset 080h.
13	DIS DEC	<b>Disable Decimation.</b> This is used in conjunction with 601 mode for 24-bit YUV/RGB output on VOP.
12	601 MODE	<b>Enable 601 Mode.</b> 0: Disable. 1: Enable.
11	VBI	<b>Vertical Blanking Interval.</b> When this bit is set to 1, the Task bit (bit 9) is used to indicate VBI data.  In BT.656 mode, the TASK bit (bit 9) in the EAV/SAV is fixed at 1, if this VBI bit is set, then a value of 0 in the TASK bit location indicates VBI data.  In VIP 1.1 mode, the TASK bit in the EAV/SAV is defined such that 0 is VBI data, and 1 is active video data. Therefore, this VBI bit has no effect in VIP 1.1 mode.  In VIP 2.0 mode, the TASK bit determines the value of the TASK bit in the EAV/SAV. With the VBI bit set, the inverse of TASK indicates VBI data.
10	RSVD	<b>Reserved.</b> Reads back as 0.
9	TASK	<b>TASK.</b> Value for the Task bit in VIP 2.0 mode.
8	SGFR	<b>Signature Free Run.</b> 0: Disable. If this bit was previously set to 1, the signature process will stop at the end of the current frame. 1: Enable. If SIGE (bit 7) is set to 1, the signature register captures data continuously across multiple frames.
7	SIGE	<b>Signature Enable.</b> 0: Disable. VP Memory Offset 808h[31:0] is reset to 0000_0000h and held (no capture). 1: Enable. The next falling edge of VSYNC is counted as at the start of the frame to be used for CRC checking with each pixel clock beginning with the next VSYNC.  If the SGFR bit (bit 8) is set to 1, the signature register captures the pixel data signature continuously across multiple frames.  If SGFR is cleared to 0, a signature is captured for one frame at a time, starting from the next falling VSYNC.  After a signature capture is complete, VP Memory Offset 808h[31:0] can be read to determine the CRC check status. Then proceed to reset the SIGE which initializes VP Memory Offset 808h[31:0] as an essential preparation for the next round of CRC checks.

## VOP\_CONFIG Bit Descriptions (Continued)

Bit	Name	Description
6	SC120X_MODE	<b>SC120X Compatible Mode.</b> Creates EAV/SAV codes consistent with the AMD Geode™ SC1200 and SC1201 processor's VOP. 0: Normal mode. 1: SC1200/SC1201 compatible mode. Set to 1 for BT.601 mode.
5:4	422_MODE	<b>4:4:4 to 4:2:2 Conversion Algorithm.</b> Selects which method is used to convert 4:4:4 data to 4:2:2. 00: 4:2:2 Co-sited. 01: 4:2:2 Interspersed (U,V samples from respective co-samples). 10: 4:2:2 Interspersed (U,V samples from alternating successive samples). 11: Not used.
3	EXT_VIP_CODES	<b>Extended VIP SAV Codes.</b> Additional SAV codes not defined in VIP 2.0 spec, but used in numerous available other applications (also used in BT.656). 0: Do not use extended codes. 1: Use extended codes. Note: Selecting BT.656 mode (in bits [1:0]) automatically uses the extended codes.
2	VIP_LEVEL	<b>VIP 2.0 Level Selection.</b> 0: VIP 2.0 Level I (8-bit), 601 8-bit. 1: VIP 2.0 Level II (16-bit), 601 16-bit.
1:0	VIP_MODE	<b>VIP Mode.</b> Selects between VESA VIP standards. 00: VOP disabled (logic 0's on data buses). 01: VIP v1.1. 10: VIP v2.0/ BT.601. Selects VIP v2.0 or BT.601 if 601 MODE bit (bit 12) is set. 11: BT.656.

## 6.8.3.52 Video Output Port Signature (VOP\_SIG)

VP Memory Offset 808h

Type RO

Reset Value 00000000\_00000000h

## VOP\_SIG Register Map

63	62	61	60	59	58	57	56	55	54	53	52	51	50	49	48	47	46	45	44	43	42	41	40	39	38	37	36	35	34	33	32
RSVD																															
31	30	29	28	27	26	25	24	23	22	21	20	19	18	17	16	15	14	13	12	11	10	9	8	7	6	5	4	3	2	1	0
CRC																															

## VOP\_SIG Bit Descriptions

Bit	Name	Description
63:32	RSVD	<b>Reserved.</b> Reads back as 0.
31:0	CRC	<b>32-Bit CRC.</b> 32-Bit Signature when in 32-bit CRC mode.

## 6.9 Video Input Port

### 6.9.1 Features

- VESA 1.1, 2.0 and BT.601, BT.656 compliant, 150 MHz (excludes host interface).
  - Standard 9 or 17 pin interface (8/16 data + clock)
  - 8/16-bit BT.656 video
  - TASK A/B video and VBI (two video streams)
  - 8/16-bit ancillary data
  - HD capable (up to 1280x720 progressive scan, 1920x1080 interlaced)
  - VIP 1.1 compatible mode (8 bit)
- 8/16-bit BT.601 type input video with HSYNC and VSYNC
- 8-bit message and streaming video transfer mode
  - (8 + clock + control on vid[10:8])
- Video data stored in linear or planar buffers
- Even line or even field decimation (4:2:2 -> 4:2:0 translation)
- Automatic paging for multi-frame storage

- Provides full frame buffer generation from interlaced input (Weave)
- Mutli-burst GLIU packets (programmable)
- Internal loopback using VOP outputs as source data
- vip\_sync\_to\_pin output pin to request next frame or data packet from external data source (GenLock)
- vip\_sync\_to\_vg output to DC/VP for frame synchronization (VSYNC indication)
- frame\_to\_vg output to DC/VP for frame synchronization (odd/even field indication)
- vip\_int output for interrupt generation on frame/field/line boundaries

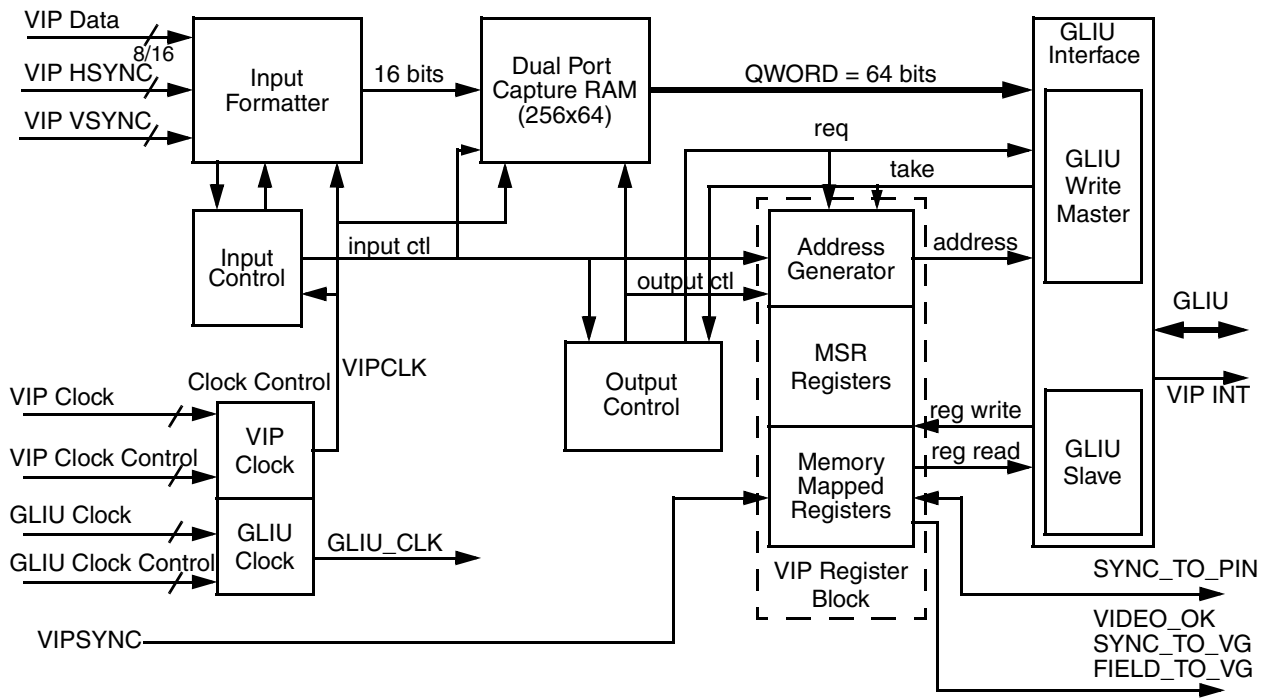
#### 6.9.1.1 Performance Metrics

- System goals:
- 150 MHz video interface
- 400 MHz GLIU interface
- Adequate GLIU bandwidth in HD capture mode (HD VIP requires ~20 million QWORDS/sec)
- GLIU Latency requirements

**Table 6-72. VIP Capabilities**

Input	Output (to memory)	Memory Storage	Supports	Task
YUV 4:2:2 Interlaced (8/16-bit) SD/HD	YUV 4:2:2	Linear, Single Frame Buffer	Weave	A or B
	YUV 4:2:2	Planar, Single Frame Buffer	Not Applicable	A or B
	YUV 4:2:2	Linear, Odd/Even Field Buffers	Bob	A or B
	YUV 4:2:2	Planar, Odd/Even Field Buffers	Not Applicable	A or B
	YUV 4:2:0	Planar, Single Frame Buffer	Rotation/Weave	A or B
	YUV 4:2:0	Planar, Odd/Even Field Buffers	Rotation/Bob	A or B
YUV 4:2:2 Progressive (8/16-bit) SD/HD	YUV 4:2:2	Linear, Single Frame Buffer	Standard Mode	A or B
	YUV 4:2:2	Planar, Single Frame Buffer	Not Applicable	A or B
	YUV 4:2:0	Planar, Single Frame Buffer	Rotation	A or B
YUV 4:2:0	YUV 4:2:0	Linear	SC1200 Compatible	A or B
VBI Data (8/16-bit)	VBI Data	Linear	VBI Data	A or B
Ancillary Data (8/16-bit)	ANC Data	Linear, Circular Buffer	Ancillary Data	N/A
Message Data (8-bit only)	MSG Data	Linear, Dual Buffers	Message Data	N/A
Streaming Data (8-bit only)	RAW Data	Linear, Dual Buffers	RAW Data	N/A

### 6.9.2 VIP Block Descriptions



Planar mode: 512 byte(64 QWORDS) YUV, Ancillary FIFO  
 Linear mode: 1536 byte(192 QWORDS) Video, 256 (64 QWORDS) byte Ancillary FIFO

**Figure 6-39. VIP Block Diagram**

### 6.9.2.1 Input Formatter

The Input Formatter receives 8- or 16-bit VIP input data, It does a 4:2:2 to 4:2:0 translation (if enabled) and formats it into either linear data or planar data for storage in the Capture RAM.

### 6.9.2.2 Input Control

The Input Control block operates in either VIP 2.0 16-bit mode, VIP 2.0 8-bit mode, VIP 1.1 compatible mode, Message Passing mode, Data Streaming mode, or BT.601 Input mode. The Input Control block decodes preamble and status from EAV/SAV and ancillary packets as well as start/stop control for message passing packets or HSYNC/VSYNC timing in BT.601 like input mode and generates control to the Input Formatter and Capture RAM. Video frame timing is decoded and passed on to the Address Generator and GLIU. The VIP input state machine is implemented in the Input Control block.

It should be noted that values from the configuration and control registers are synchronized to the video clock before being used by the Input Control block.

The VIP Input Control block contains:

- A state machine that keeps track of the video stream protocol.
- Logic to infer the odd/even VBI/ancillary packet information necessary to store data in memory.
- Sequencing control generation for the Input Formatter.
- Generation of start and stop capture, as well as capture active status.
- Line start and end logic.

### 6.9.2.3 VIP Capture RAM

The Capture FIFO is a 256 WORDx64bit dual port RAM. The input side is driven by the VIP clock. The output side is driven by the GLIU clock. The memory is divided into a 192 QWORD buffer for video and a 64 QWORD buffer for ancillary data when linear buffers are defined in system memory. It is partitioned into four 64 QWORD buffers when planar buffers are defined in system memory. One 64 QWORD buffer is used for each of the Y, U, V and ancillary data types. Data is stored in QWORDS. The watermark at which the FIFO begins emptying is programmable. Generally, a minimum of eight QWORDS are stored in a buffer before GLIU write. This enables two consecutive burst write requests to be issued, which should provide the most efficient cycle times to system memory. Programmable threshold level flags are available to monitor data levels. This should be helpful in debugging. Memory BIST is implemented and can be invoked from the JTAG logic from a MSRs. The memory can also be read/written using VIP memory mapped registers.

### 6.9.2.4 VIP Register Block

The VIP register block contains the Address Generator, MSR registers and memory mapped registers.

The Address Generator supports up to four data streams (Y, Cr, Cb, and ancillary). Each data stream has an independent logical FIFO. The Capture RAM is partitioned into four FIFOs for planar storage mode (Y, Cr, Cb, and ancillary) each being 64 QWORDS deep. In linear storage mode the Capture RAM is partitioned into two FIFOs (Y = 192 QWORDS, ancillary = 64 QWORDS). Four `vip_output_addr` blocks provide individual FIFO management and the VIP Output Control block controls the time-slicing of GLIU request for each FIFO. A separate buffer (system memory address) is maintained for each data type as described by Table 6-74 on page 475. The video base addresses registers are double buffered so address updates can be made for the next frame while the current frame is being processed.

The memory mapped registers are contained in the VIP register block. Interrupt generation, and logic for updating the base registers at frame boundaries is also implemented in this block.

### 6.9.2.5 GLIU Interface

The GLIU provides a standard interface to the AMD Geode LX processor. The VIP is both a write master and a slave on this bus.

As a write master, the VIP performs write requests to send single beat writes, or a burst of four QWORDS to memory. The VIP is considered a low-bandwidth isochronous master to the GLIU. A FIFO watermark threshold is programmable, which allows the write transaction priority to be increased when the data count in the FIFO exceeds the threshold. Handshaking exists between the GLIU master and the Output Control/Address Generation blocks so that address and data is supplied at the correct cycles.

As a slave, the VIP stores register data from the GLIU and returns register data being read by the GLIU. Bursts are not supported by the slave interface. Both MSRs and memory mapped registers are accessible through the slave interface. The front end control generates the per-byte write enables to all registers except the base registers.



### 6.9.3 Functional Description

The Video Input Port (VIP) receives 8- or 16-bit video or ancillary data, 8-bit message data, or 8-bit raw video, and passes it to data buffers located in system memory. The primary operational mode is as a compliant VIP 2.0 slave. The VIP 2.0 specification defines the protocol for receiving video, VBI, and ancillary data. The addition of the Message Passing and Data Streaming modes provide flexibility in receiving non-VIP 2.0 compliant data streams. The VIP is essentially a DMA engine. Input data is packed into QWORDS, buffered into a FIFO, and sent to system memory over the GLIU. The VIP masters the internal GLIU and transfers the data from the FIFO to system memory. The maximum input data rate (8 or 16 bits) is 150 MHz. The GLBus (64 bits) operates from 200-400 MHz corresponding to the DDR clock rate to external memory.

The VIP can successfully input line sizes as small as 12 clocks with 20 clocks of blanking, with a 16-bit data/100 MHz VIP clock rate at 400 MHz GLIU, when the VIP's priority is equal to that of the DC. The limitation has to do with the total line length (active data + blanking time). Any size of active data can be received if a reasonable amount of blanking is provided. The above case corresponds to a 6-pixel line. This is likely smaller than anything that realistically will be received (and at a higher frequency than the 75 MHz max). The VIP line size limitation is determined by the input frequency and the GLIU latency. The worst case is with a high frequency VIP clock and low frequency GLIU clock in a busy system. The VIP FIFO Line Wrap Interrupt (INT) is generated if the line is not received correctly. If this INT occurs, VIP priority should be increased and/or the blanking time of the input line increased. As there is no specification/requirement regarding VIP minimum line size, it is recommended that any non-standard input have ~100 clocks of blanking. This prevents any special priority requirements for "postage stamp" size frames.

### 6.9.4 VIP Operation Modes

The VIP provides direct hardware compatibility with the VESA 2.0 Standard (VIP 2.0), Level II. VIP 2.0 data is a simplified BT.656 video format. The simplification is due to VIP only having to receive data. (VIP does not concern itself with specific frame timing) The data the VIP receives is only stored in system memory. In addition to receiving BT.656 video format data, the VIP can also receive 8-bit message data and 8-bit streaming data, allowing the AMD Geode CS5536 companion device connected to the VIP to load data directly into the AMD Geode LX processor's system memory. The Message Passing and Data Streaming modes are not defined in the VESA 2.0 specification. The VIPSYNC output provides a software controlled output that can be used for frame/data synchronization with output devices that support data throttling. VIP must be configured to receive specific data types. The following input modes are supported by the VIP.

- Mode 1a - VIP 1.1 compatible mode (BT.656 data with following notes):

- Task bit is used to indicate VBI data within the video stream (T = 0 for VBI Data, T = 1 for active video).
- Video data is stored in the Task A video base address. VBI data is saved in the Task A VBI base address.
- Video Flags T, F, and V can only be changed in the EAV code.
- During vertical blanking there must be a minimum of one SAV/EAV scan line.
- 8-bit data only (EAV/SAV packets + ancillary data packets).
- Mode 1b - 8-bit VIP 2.0 Level I mode (BT.656 data with following notes):
  - Video Flags T, F, and V are valid in the EAV and SAV code, valid values must appear no later than the SAV of the first scan line of the next active region.
  - Task bit differentiates between two video streams. These streams can be interleaved at a scan or field rate.
  - V bit differentiates between active video and VBI data (V = 1 for VBI data, V = 0 for active video).
  - During vertical blanking there must be a minimum of one SAV/EAV scan line.
  - New Video Flags - The P Nibble is redefined as [NON\_INT, REPEAT, Reserved, EXT\_FLAG].
  - 8-bit data only (EAV/SAV packets + ancillary data packets).
- Mode 1c - 16-bit VIP 2.0 Level II mode (BT.656 data with following notes):
  - Video Flags T, F, and V are valid in the EAV and SAV code, valid values must appear no later than the SAV of the first scan line of the next active region.
  - Task bit differentiates between two video streams. These streams can be interleaved at a scan or field rate.
  - V bit differentiates between active video and VBI data (V = 1 for VBI data, V = 0 for active video).
  - During vertical blanking there must be a minimum of one SAV/EAV scan line.
  - New Video Flags - The P Nibble is redefined as [NON\_INT, REPEAT, Reserved, EXT\_FLAG].
  - 16-bit data only (EAV/SAV packets + ancillary data packets).
- Mode 2 - Message Passing mode (8-bit):
  - vip\_vdata[8] = start\_msg, vip\_vdata[9] = end\_msg.
  - 8-bit data only.
- Mode 3 - Data Streaming mode (8-bit):
  - vip\_data[8] = start\_msg, vip\_vdata[9] = vip\_data\_enable.
  - 8-bit data only.
- Mode 4 - BT.601 mode (8/16-bit):
  - No SAV/EAV recognition. Input timing based on VSYNC and HSYNC inputs.
  - HSYNC input on pin LDEMOD, VSYNC input on pin VDDEN.
  - TFT output mode cannot be used when VIP is configured in BT.601 mode.

### 6.9.5 Mode 1a,b,c - VIP Input Data (simplified BT.656)

The VIP 2.0 specification describes an 8- or 16-bit data stream incorporating both control and data. The data/control is delivered in packets. There are two different packet types, SAV/EAV and ancillary packets. The specification also requires backwards compatibility to VIP 1.1 data formats. Three different VIP data modes are supported: VIP 1.1 compatible mode, VIP 2.0 8-bit mode, and VIP 2.0 16-bit mode. Differences in these modes are noted in the descriptions of the different packet types in Section 6.9.5.1 on page 466.

#### 6.9.5.1 SAV/EAV Packets

The SAV/EAV packets begin with 3 bytes of preamble followed by a Start of Active Video (SAV) status WORD. Active data follows. The packet ends with the reception of another 3 bytes of preamble followed by an End of Active

Video (EAV) status WORD. The preamble consists of FF-00-00. The codes FF and 00 codes are prohibited as video samples and reserved for header and synchronization purposes. The code 00 can be used within a packet to mark an empty cycle. If a 00 code appears between the SAV and EAV, that sample is ignored. Note that in 16-bit mode, only the 8 LSBs are checked. If 00, the entire 16-bit WORD is ignored. The preamble and status WORD always occurs on bits [7:0] of the input data, even in 16-bit mode. The active data is received on bits [7:0] in 8-bit mode and on bits [15:0] in 16-bit mode. The Y values appear on bits [7:0] and Cx values on bits [15:8]. Both active video and VBI data are received in SAV/EAV packets. The format of the SAV and EAV preamble and status WORD is shown in Table 6-73. A sample SAV/EAV line is shown in Figure 6-40 on page 467. A full frame is shown in Figure 6-41 on page 468.

**Table 6-73. SAV/EAV Sequence**

Parameter	D7	D6	D5	D4	D3	D2	D1	D0
Preamble	1	1	1	1	1	1	1	1
	0	0	0	0	0	0	0	0
	0	0	0	0	0	0	0	0
Status WORD	T	F	V	H	P3	P2	P1	P0

The status WORD provides the raster reference information:

T = Task BIT	0 = Task B	1 = Task A
F = Field ID	0 = Odd	1 = Even
V = Vertical blanking	0 = Active video	1 = Vertical blanking
H = Horizontal blanking	0 = Active line	1 = Horizontal blanking
P3-0 = Reserved in VIP 1.1, New Flags in VIP 2.0		

VIP 1.1 compatible mode:

- Video Flags T, F, and V can only be changed in the EAV code per the VIP 1.1 specification. These flags are only captured in the EAV code.
- In VIP 1.1, the Task bit is used to indicate VBI data within the video stream (T = 0 for VBI data, T = 1 for active video). In VIP 1.1 mode, the Task bit is used in place of the V bit to indicate VBI data.
- P3-P0 are ignored.

VIP 2.0 modes (8- or 16-bit data):

- Video Flags T, F, and V are valid in the EAV and SAV code. Valid values must appear no later than the SAV of the first scan line of the next active region.
- Task bit differentiates between two video streams. These streams can be interleaved at a line or field rate.
- V bit differentiates between active video and VBI data (V = 1 for VBI data, V = 0 for active video).

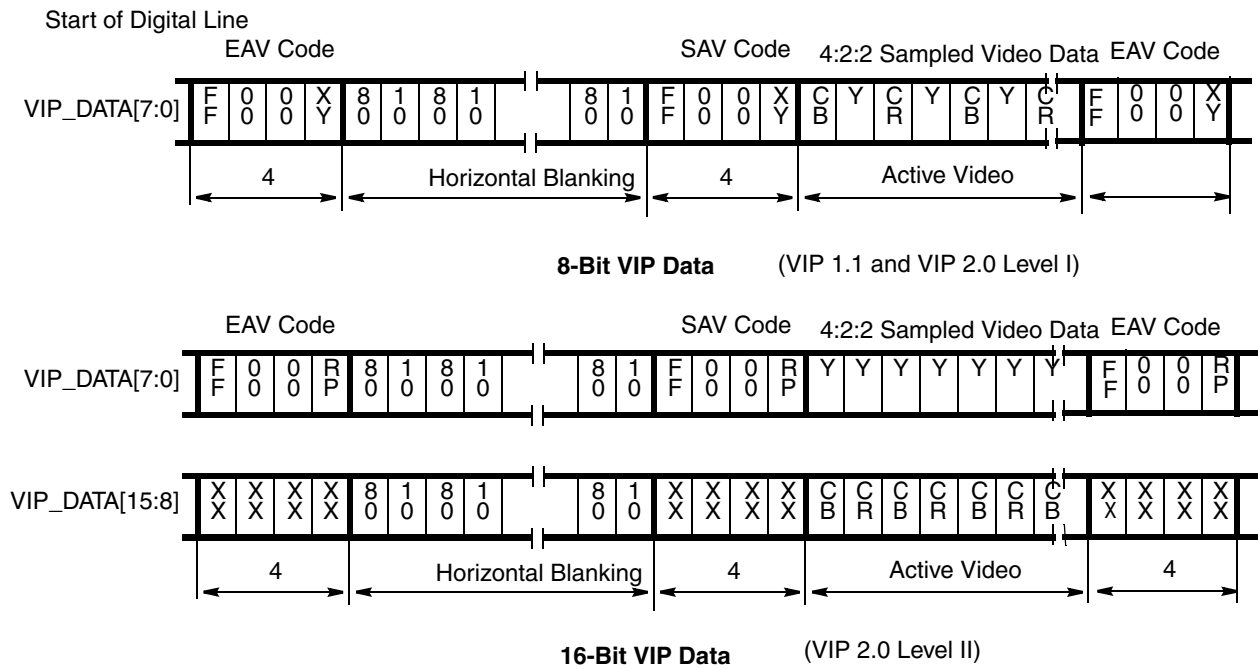
- New Video Flags - The P Nibble is redefined as [NON\_INT,REPEAT,Reserved,EXT\_FLAG]:
  - NON\_INT: 1 = non-interlaced source, 0 = interlaced source (not used).
  - REPEAT: 1 = Repeat field in 3:2 pull-down, 0 = not a repeat field (repeat fields can be ignored by VIP). The repeat flag must be set in the SAV for every line in the field. The line will be saved to memory if the repeat flag is not set. (This function needs to be enabled in VIP Memory Offset 04h[29]).
  - EXT\_FLAG: 1 = Extra flag byte follows this EAV, 0 = no extra flag byte (not implemented).

**VIP 2.0 Video Flags**

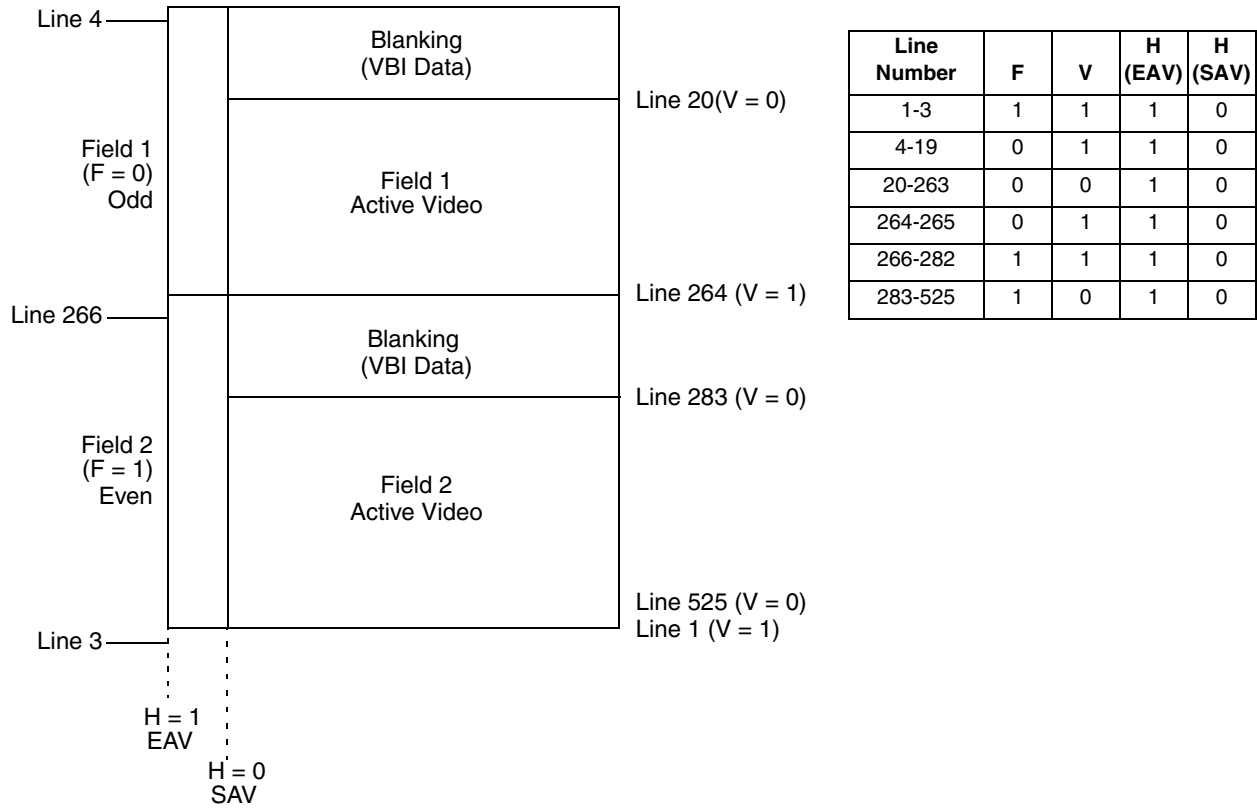
Two new video flags are defined in the VIP 2.0 specification to decode whether the input video is interlaced or noninterlaced and whether the data is merely a repeated field. These flags are meant to enable VIP to handle Bob and Weave, as well as 3:2 pull down in hardware. The new flags are embedded in the lower nibble of the SAV and EAV header. The non-interlace flag NON\_INT (bit 3 of the status WORD) is ignored by the VIP. The video stream must be known and the software must set up the appropriate base and pitch addresses to store the video into system memory. The repeat flag (bit 2 of the status WORD) can be decoded by the VIP if the feature is enabled in the VIP Control Register 2 (VIP Memory Offset 04h[29]). The

repeat flag is set during 3:2 pull down. In 3:2 pull down, fields are repeated to increase the frame rate. The VIP ignores fields (lines) with the repeat flag set. This reduces the amount of data being transferred to system memory, reducing overall bandwidth requirements. Additional flag bytes are also supported in the VIP 2.0 specification. These extra flag bytes can only occur during EAV (NOT SAV). The VIP ignores extra flag bytes.

**Note:** Since the extra flag byte can only occur during EAV, they can be ignored without effecting the reception of following SAV/EAV packets.



**Figure 6-40. BT.656, 8/16-Bit Line Data**



In VIP 1.1 mode, the T,F,V video flags are only captured from the EAV code. In VIP 2.X modes, these flags are captured from both the SAV and the EAV codes. (The H bit is always captured to distinguish between and SAV and EAV code). Note that for VIP 1.1 mode, there must be a minimum of one SAV/EAV scan line during vertical blanking in order for the VBlank flag to transition from 0->1->0.

An End-of-Frame event is detected the same in VIP 1.1 and VIP 2.0 modes. (A 0->1 transition of VBlank when F = 1 causes an End-of-Frame event during interlaced video, A 0->1 transition of V-Blank causes an End-of-Frame event during progressive scan video) An End-of-Frame event is used for starting/stopping capture and for updating buffer addresses. Line #1 of a frame does not necessarily coincide with the End-of-Frame event. Line #1 is specified differently with respect to VBlank depending on the frame type (resolution/interlaced/...). When line#1 is defined other than on the falling transition of VBlank, VBI data received after the V-Blank transition will be stored in updated buffer address. VBI data is generally not sent during this time.

**Figure 6-41. 525 line, 60 Hz Digital Vertical Timing**

### 6.9.5.2 Ancillary Packets

Ancillary packets are received during vertical and/or horizontal blanking. The ancillary packet has a 6-byte header of 00-FF-FF-DID-SDID-NN. The first three bytes are the pre-amble. The DID and SDID bytes are the data identifier and the secondary data identifier bytes. The NN byte is the data count and specifies the length of the ancillary data block in DWORDs (4-byte blocks). The entire ancillary data packet is stored to memory, including all 6 bytes of preamble/header. See Section 6.9.10 on page 475 for further

explanation. There is no restriction on the code in the data section of the packet (codes 00 and FF are allowed) The SAV/EAV packet preamble detection circuitry is disabled during the reception of these NN blocks of data to allow reception of 00, FF codes. The active data is received on bits [7:0] in 8-bit mode, [9:0] in 10-bit mode and on [15:0] in 16-bit mode.

A sample ancillary packet is shown in Figure 6-42.

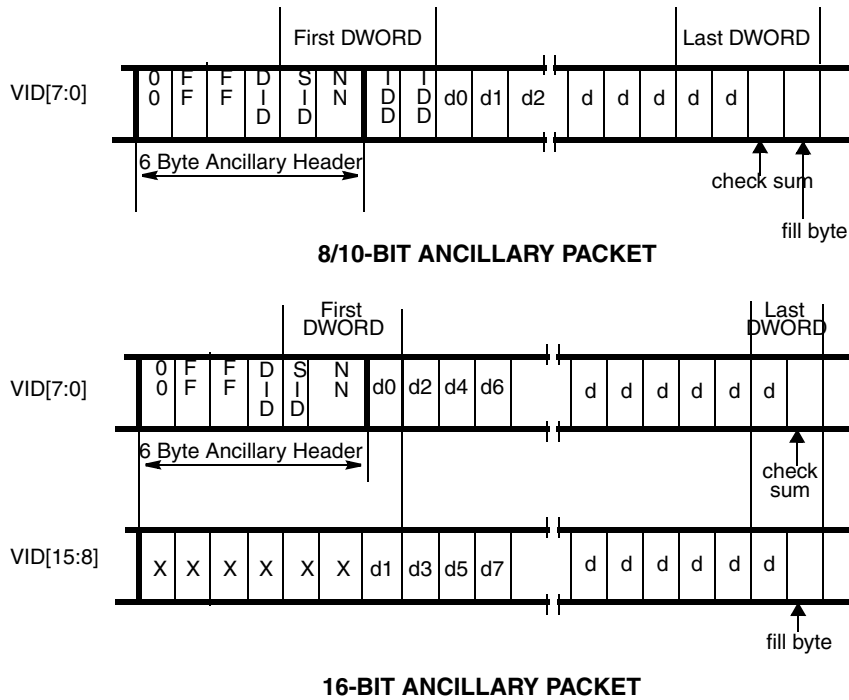


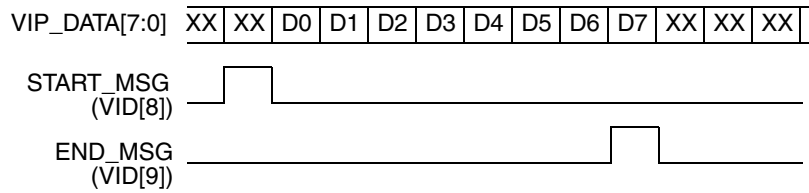
Figure 6-42. Ancillary Data Packets

**6.9.6 Message Passing Mode**

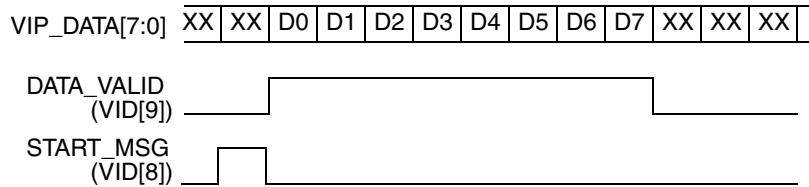
The Message Passing mode (MSG) allows an external device to pass raw data packets to the AMD Geode LX processor system memory (see Figure 6-43). In Message Passing mode, VID8 is redefined as a start message indication and VID9 is redefined as an end message indication. Video data reception (SAV/EAV packets and ancillary packets) is disabled while in Message Passing mode.

**6.9.7 Data Streaming Mode**

The Data Streaming mode (STRM) allows an external device to pass raw data to the processor system memory (see Figure 6-44). When in Data Streaming mode, the VID9 data pin is redefined as a DATA\_VALID control input. VID8 is the START\_MSG indicator. The VIP stores all data during the time that the DATA\_VALID input is active. The data is stored sequentially into system memory. Figure 6-44 shows the Data Streaming format. Video data reception (SAV/EAV packets and ancillary packets) is disabled while in Data Streaming mode.



**Figure 6-43. Message Passing Data Packet**

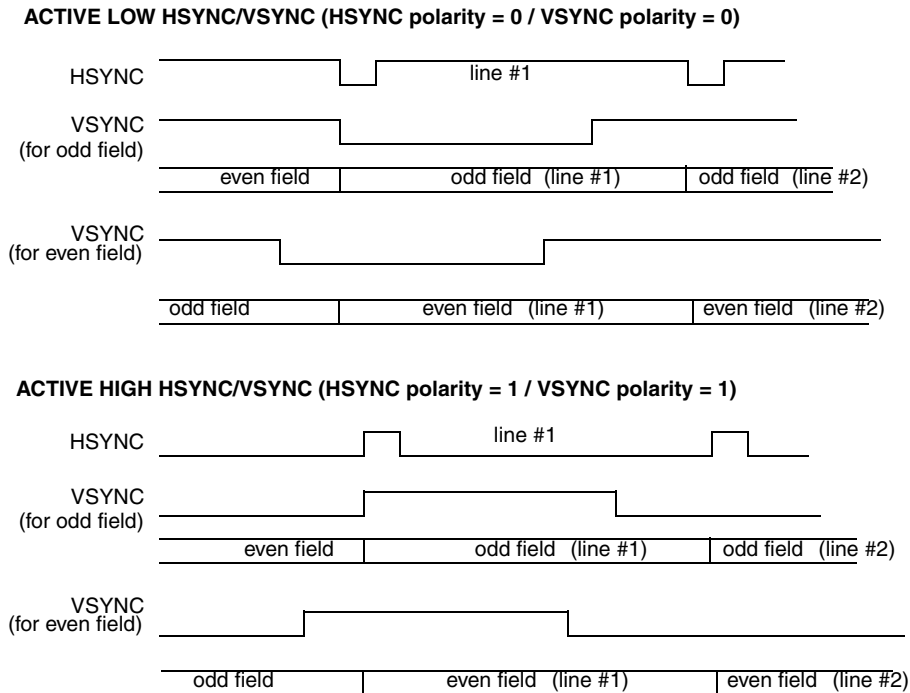


**Figure 6-44. Data Streaming Data Packet**

### 6.9.8 BT.601 Mode

BT.601 mode allows reception of 8- or 16-bit video input which consists of HSYNC, VSYNC, and 8/16 bit data. Vertical and horizontal start/stop registers provide the information for data capture in each field/frame. The BT.656 SAV/EAV codes (if present) are ignored. Frame/line timing is derived from the HSYNC and VSYNC inputs only. Odd/even field is determined by the leading edges of VSYNC and HSYNC. Default field detection is shown in Figure 6-45. A detection window is programmable using the VIP Memory Offset 50h. If the leading edge of VSYNC occurs

within the window, the field is odd. If the leading edge of VSYNC occurs outside the window, the field is even. The VIP Memory Offset 50h default value requires that the HSYNC and VSYNC leading edges occur simultaneously for odd field detection (see Figure 6-46 on page 472). The horizontal and vertical input timings of the input video frame are also programmable. See Figure 6-47 and Figure 6-48.

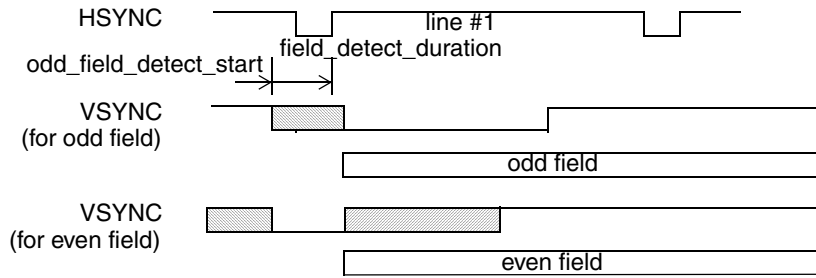


Odd field is indicated when leading edge of VSYNC and the leading edge of HSYNC occur simultaneously (VIP allows for a programmable detection window for odd field).

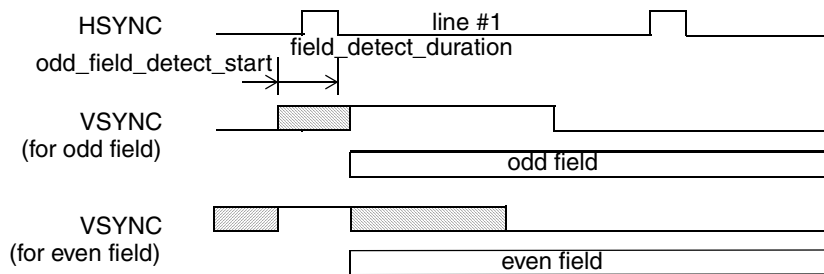
Even field is indicated when leading edge of VSYNC occurs prior to the leading edge of HSYNC.

**Figure 6-45. BT.601 Mode Default Field Detection**

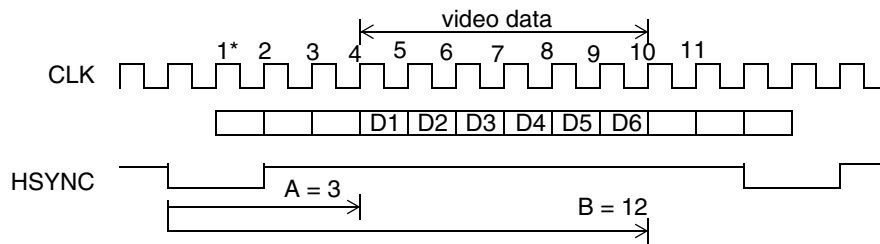
**ACTIVE LOW HSYNC/VSYNC (HSYNC Polarity = 0 / VSYNC Polarity = 0)**



**ACTIVE HIGH HSYNC/VSYNC (HSYNC Polarity = 1 / VSYNC Polarity = 1)**



**Figure 6-46. BT.601 Mode Programmable Field Detection**

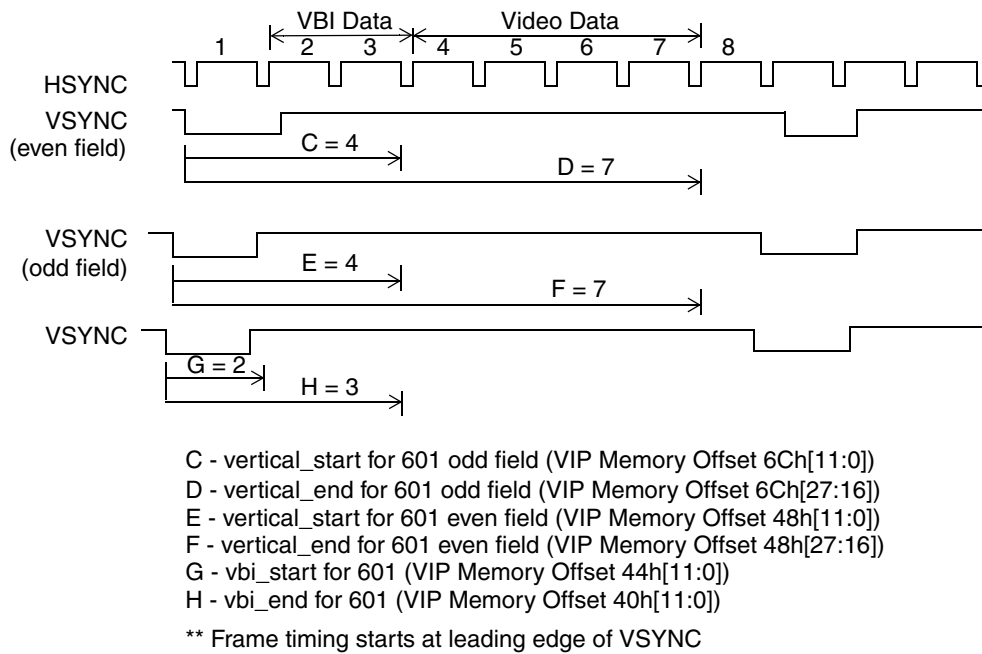


A - horizontal\_start for 601 (VIP Memory Offset 3Ch)  
 B - horizontal\_end for 601 (VIP Memory Offset 38h)

\* Clock #1 occurs at leading transition of HSYNC

**Figure 6-47. BT.601 Mode Horizontal Timing**





**Figure 6-48. BT.601 Mode Vertical Timing**

### 6.9.9 YUV 4:2:2 to YUV 4:2:0 Translation

The VIP provides the option to translate incoming 4:2:2 co-sited video to YUV 4:2:0. The U and V values of even lines are simply discarded. No filtering is performed. VIP stores the 4:2:0 data to system memory in a planar format. In planar format, the Y, U, and V data is partitioned into separate buffers. A single Y, U, V buffer (three buffers) can be used in the case of progressive scan or with interlaced data when using Weave. Two sets of buffers (six buffers) are used to store the odd and even field data separately when using the Bob method of de-interlacing.

Figure 6-49 on page 474 illustrates the positioning of the YCbCr samples for the 4:2:2 and 4:2:0 formats when:

- 1) Receiving a progressive scan frame.
- 2) Receiving interlaced odd and even fields for use with the Bob display mode.
- 3) For receiving odd and even fields with the Weave display mode.

In addition to the standard 4:2:2 translation, VIP can also decimate all U/V values in the even field.



### 6.9.10 Software Model

The VIP receives data and stores it into system memory. The VIP input modes with associated data types are shown in Table 6-74. VIP 2.0 is the VESA VIP 2.0 Level I (8-bit) standard or the VESA VIP 2.0 Level II (16-bit) standard. VIP 1.1 is the VESA (8-bit) standard in which only a single video stream is supported and the TASK bit is used to distinguish between video and VBI data. MSG is the 8-bit Message Passing mode, and STRM, the Data Streaming mode, provides support for generic 8-bit data streaming.

MSG and STRM modes are proprietary data transfer formats and are not defined in the VESA VIP specification.

Table 6-74 defines the data types received in each mode. VIP 2.0 supports nine different data types. This allows reception of two separate video streams (Task A and B) plus ancillary data. VIP 1.1 mode supports five data types (Task A only). One data type is associated with the MSG and STRM modes.

**Table 6-74. VIP Data Types / Memory Registers**

Mode	Data Type	T F V (Flags)	Base Register	Pitch/Size Register	Planar Registers
VIP 2.0	Task A, Odd Field, Active Video	1 0 0	VIP_TASK_A_VID_ODD_BASE	VIP_TASK_A_VID_PITCH	VIP_TASK_A_U_OFFSET VIP_TASK_A_V_OFFSET
	Task A, Even Field, Active Video	1 1 0	VIP_TASK_A_VID_EVEN_BASE		VIP_TASK_A_U_OFFSET VIP_TASK_A_V_OFFSET
	Task A, Odd Field, VBI	1 0 1	VIP_TASK_A_VBI_ODD_BASE		N/A
	Task A, Even Field, VBI	1 1 1	VIP_TASK_A_VBI_EVEN_BASE		N/A
	Task B, Odd Field, Active Video	0 0 0	VIP_TASK_B_VID_ODD_BASE	VIP_TASK_B_VID_PITCH	VIP_TASK_B_U_OFFSET VIP_TASK_B_V_OFFSET
	Task B, Even Field, Active Video	0 1 0	VIP_TASK_B_VID_EVEN_BASE		VIP_TASK_B_U_OFFSET VIP_TASK_B_V_OFFSET
	Task B, Odd Field, VBI	0 0 1	VIP_TASK_B_VBI_ODD_BASE		N/A
	Task B, Even Field, VBI	0 1 1	VIP_TASK_B_VBI_EVEN_BASE		N/A
	Ancillary	N/A	VIP_ANC_MSG_1_BASE	VIP_ANC_MSG_SIZE	N/A
VIP 1.1	Task A, Odd Field, Active Video	1 0 0	VIP_TASK_A_VID_ODD_BASE	VIP_TASK_A_VID_PITCH	VIP_TASK_A_U_OFFSET VIP_TASK_A_V_OFFSET
	Task A, Even Field, Active Video	1 1 0	VIP_TASK_A_VID_EVEN_BASE		VIP_TASK_A_U_OFFSET VIP_TASK_A_V_OFFSET
	Task A, Odd Field, VBI	0 0 1	VIP_TASK_A_VBI_ODD_BASE		N/A
	Task A, Even Field, VBI	0 1 1	VIP_TASK_A_VBI_EVEN_BASE		N/A
	Ancillary	N/A	VIP_ANC_MSG_1_BASE	VIP_ANC_MSG_SIZE	N/A
BT. 601	Task A, Odd Field, Active Video	1 0 0	VIP_TASK_A_VID_ODD_BASE	VIP_TASK_A_VID_PITCH	VIP_TASK_A_U_OFFSET VIP_TASK_A_V_OFFSET
	Task A, Even Field, Active Video	1 1 0	VIP_TASK_A_VID_EVEN_BASE		VIP_TASK_A_U_OFFSET VIP_TASK_A_V_OFFSET
	Task A, Odd Field, VBI	0 0 1	VIP_TASK_A_VBI_ODD_BASE		N/A
	Task A, Even Field, VBI	0 1 1	VIP_TASK_A_VBI_EVEN_BASE		N/A
MSG	Message passing	N/A	VIP_ANC_MSG_1_BASE, VIP_ANC_MSG_2_BASE	VIP_ANC_MSG_SIZE	N/A
STRM	Data Streaming	N/A	VIP_ANC_MSG_1_BASE, VIP_ANC_MSG_2_BASE		N/A

### 6.9.10.1 Video Data Buffers

Video data buffers can be organized in linear or planar formats. Linear buffers pack YUV values contiguous in memory. Planar buffers have separate subbuffers for each set of YUV values in a field or frame. The VIP Control 1 register (VIP Memory Offset 00h[4]) determines if the video storage format is linear or planar.

In linear format, the first video line is stored beginning at the `vid_base` address, the second line is stored beginning at `vid_base + pitch`, the third line at `task_base + (2 x pitch)` and so on until the end of the field/frame. See Figure 6-51 on page 477 for an example of a 4:2:2 SAV/EAV packets stored in system memory in a linear format.

In planar format, the Y buffer begins at the `task_base` address, the U buffer begins at the (`vid_base + U_buffer_offset`), and the V values start at the (`vid_base + V_buffer_offset`). The pitch value for Y is `vid_pitch`. The pitch value for V and U is `task_A_UV_pitch` (for Task A UV data) or `task_b_pitch/2` (Task b UV data). In 4:2:2 or 4:2:0 video, there are twice as many Y data values per line as there are U or V values. Additional odd/even offsets and pitch registers are provided for Task A data. Input U/V values can be decimated (even lines or even fields). This further reduces the U and V data to 1/4 of the Y data.

See Figure 6-51 on page 477 and Figure 6-52 on page 478 for examples of SAV/EAV packets stored in linear buffer and planar buffer format.

### 6.9.10.2 VBI Data Buffers

The VBI data packets are stored in linear format. VBI data is essentially a line of video that occurs during vertical blanking. The first VBI line is stored beginning at `vbi_base`, the second line is stored beginning at `vbi_base + vid_pitch`, the third line at `vbi_base + (2 x vid_pitch)` and on until the end of the vertical blanking period.

### 6.9.10.3 Ancillary Data Buffers

Ancillary data packets are stored starting at the buffer address defined by `anc_msg_1`. Packet storage continues to address `anc_msg_1 + anc_msg_size` at which point the address is wrapped back around to `anc_msg_1`. When a new packet is received, the packet count is incremented. When software reads a packet from the buffer, it decrements the count by writing a 1 to the Decrement Ancillary Packet Count bit in the VIP Status register (VIP Memory Offset 08h[18]).

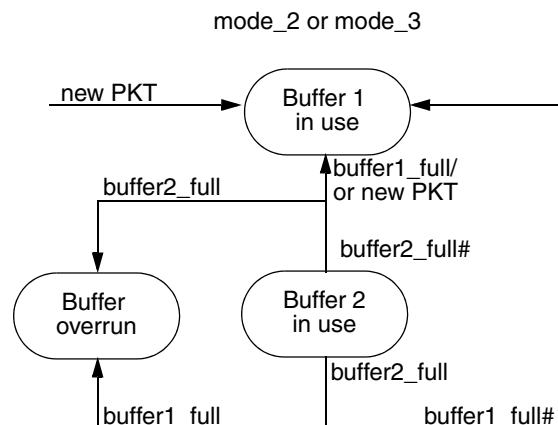
Ancillary data packets include a checksum. After packet reception, the internally generated checksum is compared to the checksum sent with the ancillary packet. If these values do not compare, the packet is marked bad by writing a F0 in fill byte immediately following the checksum byte (8/16 ancillary data) or a 1111 in bits [15:12] of the checksum DWORD for 10-bit ancillary data. Parity checking is also performed on the DID, SDID, NN, and checksum WORDs. Packets with parity errors set the same error bits as when a checksum error occurs. Parity and checksum errors are reported in the VIP Status register (VIP Memory Offset 08h). They share a status bit. Parity checking can be dis-

abled via the ANCPEN bit in Control Register 2 (VIP Memory Offset 04h[26]).

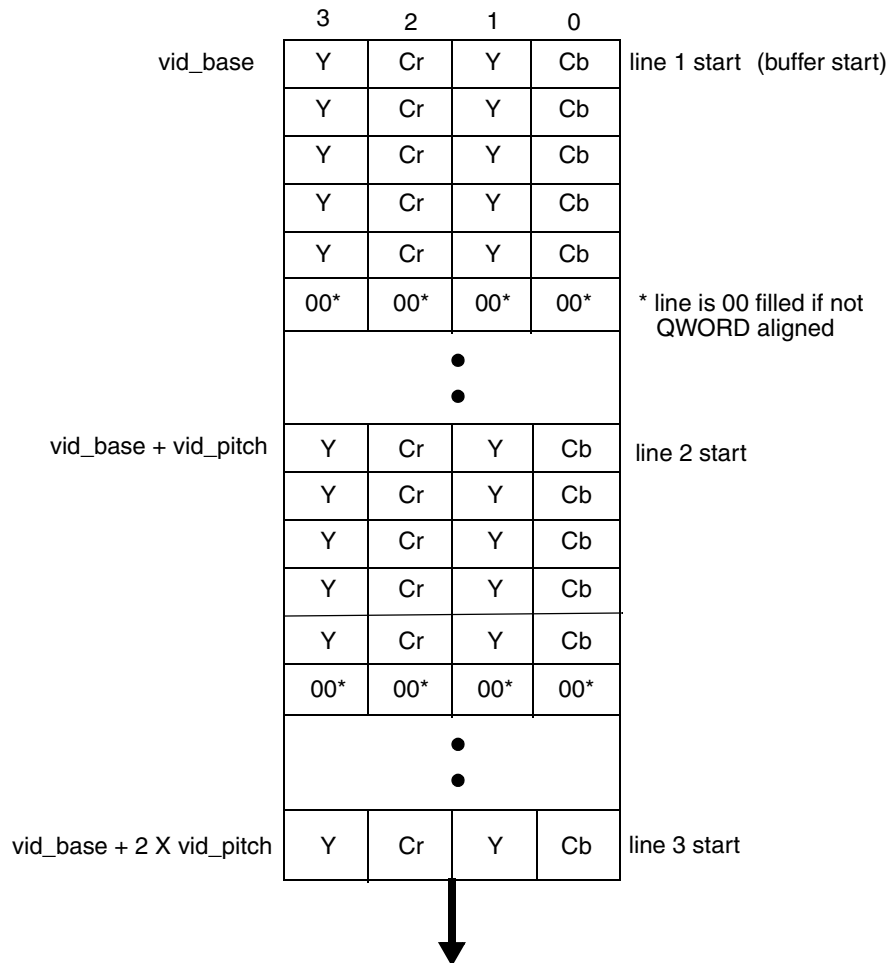
Figure 6-53 on page 479 shows an example of ancillary packets stored in system memory.

### 6.9.10.4 Message Passing/Data Streaming Modes

The MSG and STRM modes provide a mechanism for the AMD Geode CS5536 companion device to send raw data to the AMD Geode LX processor system memory. MSG and STRM modes have identical software models. Two buffers are used (see Figure 6-50). The `VIP_ANC_MSG_1_BASE` and `VIP_ANC_MSG_2_BASE` registers (VIP Memory Offset 58h and 5Ch) define the two buffer locations. The `VIP_ANC_MSG_SIZE` register (VIP Memory Offset 60h) defines the maximum size of each buffer. The first packet (data associated with a Start/End indication) is saved starting at `msg_1_base` address. The MB bit in Control Register 1 (VIP Memory Offset 00h[18]) determines when buffer swapping occurs. When `MB = 0`, buffers are swapped each packet. When `MB = 1`, buffers are only swapped when full. This mode might be used if a continuous data stream is being delivered. A Message Buffer Full interrupt occurs when a buffer swap occurs. Software can read the VIP Status register to determine which buffer or buffers are full. Software must reset the bit in order for the buffer to become available. The MSG Buffer Error status bit (bit 14) is set when a buffer swap occurs from buffer 1 to buffer 2 with buffer 2 being unavailable or if a buffer swap occurs from buffer 2 to buffer 1 with buffer 1 being unavailable.

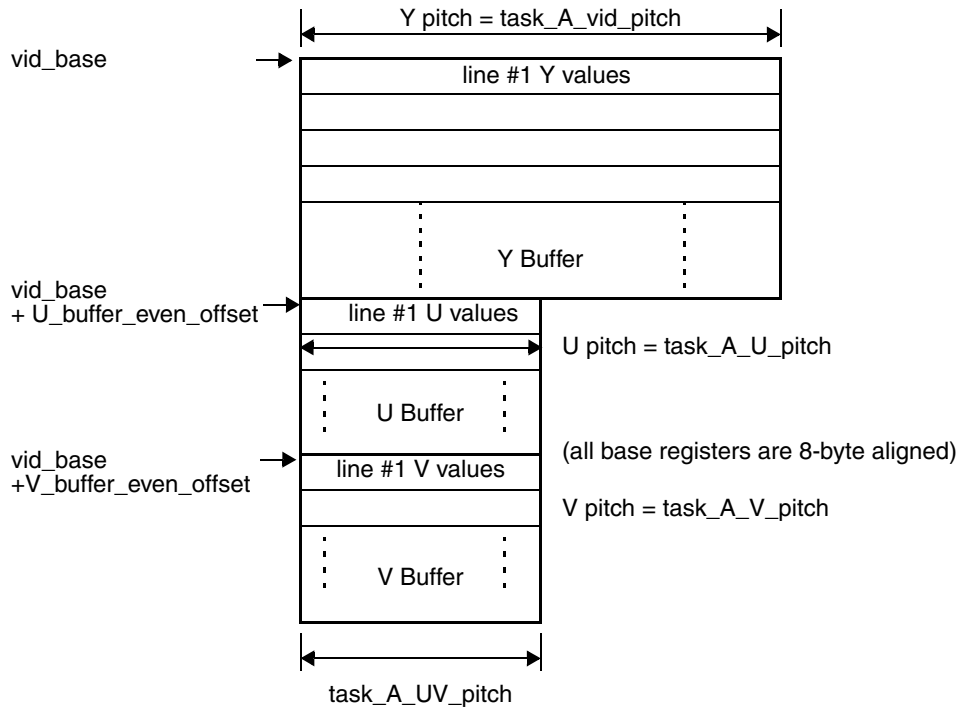


**Figure 6-50. Dual Buffer for Message Passing and Data Streaming Modes**



\* Similar buffer can exist for Task A odd video, Task A even video, Task B odd video, Task B even video, Task A odd VBI data, Task A even VBI data, Task B odd VBI data, Task B even VBI data

**Figure 6-51. Example VIP YUV 4:2:2 SAV/EAV Packets Stored in System Memory in a Linear Buffer**



\*\* Similar buffers can exist for Task A even video

\*\* Odd/even de-interlacing is not supported for Task B (Task B shares pointers between odd/even fields)

Note: Line lengths, which are not divisible by 8, will result in an odd number of U and V data for each line. When this occurs, the fill values used (for QWORD boundaries) may not be 00. This occurs only if non-standard video formats are used. The non 00 data is not part of the line.

**Figure 6-52. Example VIP YUV 4:2:0 Planar Buffer**

anc\_message\_base  
(8-byte aligned)

**8/16-BIT ANCILLARY DATA**

	3	2	1	0	
	DID	FF	FF	00	packet 1 start - buffer start
	data	data	NN=4	SDID	
	data	data	data	data	
	data	data	data	data	
	data	data	data	data	
	00*	CS	data	data	* packet is 00 filled to QWORD aligned address
	DID	FF	FF	00	packet 2 start
	data	data	NN=6	SDID	
	data	data	data	data	
	data	data	data	data	
	data	data	data	data	
	data	data	data	data	
	data	data	data	data	
	00*	CS	data	data	* packet is 00 filled if not QWORD aligned
	data	data	NN=7	SID	packet 3 start

**10-BIT ANCILLARY DATA**

	3	2	1	0	
	3FF		000		packet 1 start - buffer start
	DID		3FF		
	NN=4		SDID		
	data		data		
	data		data		
	00*		CS		* packet is 00 filled to QWORD aligned address
	3FF		000		packet 2 start
	DID		3FF		
	NN=8		SDID		
	data		data		
	data		data		
	data		data		
	data		data		
	00*		CS		* packet is 00 filled if not QWORD aligned
	3FF		000		packet 3 start

**Figure 6-53. Example VIP 8/16- and 10-bit Ancillary Packets Stored in System Memory**

### 6.9.11 Bob and Weave

Bob and Weave are two methods of outputting interlaced video, captured by the VIP, in a progressive scan format. An example of this is when VIP receives 30 Hz interlaced (NTSC format) and the data is to be displayed on a TFT panel that requires progressive scan with a 60-85 Hz refresh rate. In the Bob method, VIP stores the odd and even fields in separate buffers. This uses less bandwidth since each field is line doubled by the display controller, and displayed as a full frame. The disadvantage is that there are some observable visual effects due to the reduction in resolution. In the Weave method, VIP assembles a full frame from the two fields. The Display Controller then displays a full resolution frame. This requires more bandwidth.

#### 6.9.11.1 Bob

In the Bob method, VIP saves the even and odd fields in separate buffers. The VIP field interrupt is enabled to indicate to software when a field has been completed. A field status bit is available that indicates whether an odd or even field was received. Software can manage these field buffers so that the Display Controller always accesses fully assembled field data.

#### 6.9.11.2 Weave

In the Weave method, VIP assembles the odd field and even fields together to form the complete frame in system memory. Since both fields are rendered simultaneously, the frame must be double buffered. This allows VIP to render a frame while the Display Controller is outputting a previous frame. To assemble the odd and even fields into a single frame, the VIP must be setup such that the video data odd base address is separated from the video data even base address by one horizontal line. The video pitch register must be programmed with the value of two horizontal lines. The VIP field interrupt is enabled to indicate to software when each field has been completed. A field status bit is available that indicates whether an odd or even field was received. Software can manage these field/frame buffers so that the Display Controller always accesses fully assembled frame data.

### 6.9.12 VIP Interrupts

Software applications need synchronization events and input error indications from the VIP to manage video display and processing. Interrupts are generated by the VIP in the form of Interrupts (INT) and/or Asynchronous System Management Interrupts (ASMI). The following events can generate an INT or ASMI. These INTs/ASMI are disabled at power-up.

**FIFO Line Wrap Error** - In cases where minimum line sizes are input with a low GLIU frequency and high GLIU latency, there is a potential error condition where the VIP can receive a third line of video before the first line has been completely output. VIP can not handle more than two lines of video in its FIFO. If this condition occurs, the input video line size should be increased by increasing the blanking time between each line.

**FIFO Overflow Error** - FIFO overflows can occur if GLIU latencies become too long. If a FIFO overflow occurs, the VIP automatically resets the FIFO. Data in the FIFO is discarded. Video reception begins again at the start of the next line. No software intervention is required. This INT is generated to indicate that a FIFO overflow occurred. A high frequency of these interrupts is likely an indication of system bandwidth issues.

**FIFO Threshold Hit** - The FIFO threshold hit is a programmable count that gets compared to the number of WORDs in a FIFO. If the FIFO data level surpasses the FIFO threshold, then a FIFO threshold hit INT is generated. The request priority level is also elevated to its high value. Separate threshold values exist for video and ancillary data. This INT may be enabled for debug to determine if potential bandwidth issues are effecting video capture.

**Runaway Line (> 3000 clocks) Error** - This error occurs when a SAV code occurs, but a corresponding EAV does not. VIP Memory Offset 00h[23] (ERR\_DETECT) must be set to 1 to enable the runaway line error. A runaway line error causes video reception to stop. Video reception starts again at the beginning of the next line.



**Vertical Timing Error (Frame or Address Error) /Message Missed Error** - This error indicates a frame error or an address error. A frame error occurs when the time between VSYNCs exceeds the window defined by the VIP\_SYNC\_ERR\_COUNT register (VIP Memory Offset 78h). The VIP\_SYNC\_ERR\_COUNT register must be programmed. An address error occurs when the GLIU address equals or exceeds the address programmed in the VIP\_MAX\_ADDR register (VIP Memory Offset 14h). The A\_ERR\_EN bit must be enabled (VIP Memory Offset 04h[30] = 1). An address error causes data reception to stop. The A\_ERR\_EN must be set to a 0 to reset the Address Error so data reception can restart. Setting the VRST bit in Control Register 1 also resets the Address Error (VIP Memory Offset 00h[0]).

**Active Pixels Per Line Error** - This error is only valid when receiving BT.656 data. This INT indicates that the amount of active data received between SAV and EAV codes is not the same from one line to the next. This indicates that there is a problem in the video input data stream.

**VIP Clock Input Error** - This error indicates that the VIP input clock has stopped for 128 GLIU clocks.

**Ancillary Checksum or Parity Error** - This error indicates that a checksum value on an ancillary packet was wrong or the parity on an ancillary packet was wrong. The ancillary parity check can be disabled by setting the ANCPEN bit to 0 (VIP Memory Offset 04h[26] = 0).

**Message Buffer Full or Ancillary Threshold Packet Count Reached** - When in Message Passing mode, this indicates that a message buffer swap has occurred. The status register can be read to find out which message buffer has been filled. When in a video mode, this indicates that the number of outstanding ancillary packets has reached the threshold count programmed in VIP Memory Offset 60h.

**End of Vertical Blanking** - Indicates that a falling edge of VBLANK has occurred.

**Start of Vertical Blanking** - Indicates that a rising edge of VBLANK has occurred.

**Start of Even Field** - Indicates that the start of the even field has occurred (for interlaced video data only).

**Start of Odd Field** - Indicates that the start of the odd field has occurred (for interlaced video data only).

**Current Line = VIP Line Target** - Indicates that the video line number programmed in the VIP Current/Target register (VIP Memory Offset 10h) has been reached.

### 6.9.13 VIP Input Video Status

The VIP checks the input video for conditions that could indicate an invalid data stream. These indications are provided to software via interrupts. Another component of the video detection story is the generation of the video\_ok signal to the DC. When in GenLock mode, the VIP transfers video data to memory and synchronously to the DC extracting the video from memory and sending it on to a display. If the video data is interrupted, the DC needs to know so that it can switch over to internally generated timing and data. The video\_ok signal provides the indication that the video data being received by the VIP is OK. The ERR\_DETECT bits (VIP memory Offset 00h[23:20]) are used to enable/disable the specific checks. When an error occurs, the video\_ok signal remains 0 until the error is reset by clearing the associated interrupt pending bit in the VIP Interrupt register (VIP Memory Offset 0Ch). The following checks on the video data can be performed.

- Clock Input Error - Enabled when bit 20 = 1
- Line Input Error - Enabled when bit 21 = 1
- Runaway Line Input Error - Enabled when bit 23 = 1
- Vertical Timing Error - Enabled when bit 22 = 1
- Address Error (VIP Memory Offset 04h[30] must = 1) - Enabled when bit 22 = 1

## 6.10 Video Input Port Register Descriptions

The registers associated with the VIP are the Standard GeodeLink Device (GLD) MSRs (accessed via the RDMSR and WRMSR instructions) and VIP Configuration/Control Registers. Table 6-75 and Table 6-76 are register summary

tables that include reset values and page references where the bit descriptions are provided.

**Note:** The MSR address is derived from the perspective of the CPU Core. See Section 4.1 "MSR Set" on page 45 for more details on MSR addressing.

**Table 6-75. Standard GeodeLink™ Device MSRs Summary**

MSR Address	Type	Register Name	Reset Value	Reference
54002000h	RO	GLD Capabilities MSR (GLD_MSR_CAP)	00000000_0003C4xxh	Page 484
54002001h	R/W	GLD Configuration MSR (GLD_MSR_CONFIG)	00000000_00000000h	Page 484
54002002h	R/W	GLD SMI MSR (GLD_MSR_SMI)	00000000_ xxx7FFFh	Page 485
54002003h	R/W	GLD Error MSR (GLD_MSR_ERROR)	00000000_00000000h	Page 486
54002004h	R/W	GLD Power Management Register (GLD_MSR_PM)	00000000_00000005h	Page 487
54002005h	R/W	GLD Diagnostic MSR (GLD_MSR_DIAG)	00000000_00000000h	Page 487

**Table 6-76. VIP Configuration/Control Registers Summary**

VIP Memory Offset	Type	Register Name	Reset Value	Reference
00h	R/W	VIP Control Register 1 (VIP_CTL_REG1)	42000001h	Page 488
04h	R/W	VIP Control Register 2 (VIP_CTL_REG2)	00000000h	Page 490
08h	R/W	VIP Status (VIP_STATUS)	xxxxxxxh	Page 492
0Ch	R/W	VIP Interrupt (VIP_INT)	xxxxFFFEh	Page 494
10h	R/W	VIP Current/Target (VIP_CUR_TAR)	00000000h	Page 495
14h	R/W	VIP Max Address (VIP_MAX_ADDR)	FFFFFFFFh	Page 495
18h	R/W	VIP Task A Video Even Base Address (VIP_TASK_A_VID_EVEN_BASE)	00000000h	Page 496
1Ch	R/W	VIP Task A Video Odd Base Address (VIP_TASK_A_VID_ODD_BASE)	00000000h	Page 496
20h	R/W	VIP Task A VBI Even Base Address (VIP_TASK_A_VBI_EVEN_BASE)	00000000h	Page 497
24h	R/W	VIP Task A VBI Odd Base Address (VIP_TASK_A_VBI_ODD_BASE)	00000000h	Page 497
28h	R/W	VIP Task A Video Pitch (VIP_TASK_A_VID_PITCH)	00000000h	Page 498
2Ch	R/W	VIP Control Register 3 (VIP_CONTRL_REG3)	00000020h	Page 498
30h	R/W	VIP Task A V Offset (VIP_TASK_A_V_OFFSET)	00000000h	Page 499
34h	R/W	VIP Task A U Offset (VIP_TASK_A_U_OFFSET)	00000000h	Page 500
38h	R/W	VIP Task B Video Even Base/Horizontal End (VIP_TASK_B_VID_EVEN_BASE_HORIZ_END)	00000000h	Page 500
3Ch	R/W	VIP Task B Video Odd Base/Horizontal Start (VIP_TASK_B_VID_ODD_BASE_HORIZ_START)	00000000h	Page 501
40h	R/W	VIP Task B VBI Even Base/VBI End (VIP_TASK_B_VBI_EVEN_BASE_VBI_END)	00000000h	Page 501

Table 6-76. VIP Configuration/Control Registers Summary

VIP Memory Offset	Type	Register Name	Reset Value	Reference
44h	R/W	VIP Task B VBI Odd Base/VBI Start (VIP_TASK_B_VBI_ODD_BASE_VBI_START)	00000000h	Page 502
48h	R/W	VIP Task B Data Pitch/Vertical Start Even (VIP_TASK_B_DATA_PITCH_VERT_START_EVEN)	00000000h	Page 502
4Ch	--	Reserved	--	--
50h	R/W	VIP Task B V Offset (VIP_TASK_B_V_Offset)	00000000h	Page 503
54h	R/W	VIP Task B U Offset (VIP_TASK_B_U_OFFSET)	00000000h	Page 504
58h	R/W	VIP Ancillary Data/Message Passing/Data Streaming Buffer1 Base Address (VIP_ANC_MSG_1_BASE)	00000000h	Page 504
5Ch	R/W	VIP Ancillary Data/Message Passing/Data Streaming Buffer 2 Base Address (VIP_ANC_MSG_2_BASE)	00000000h	Page 505
60h	R/W	VIP Ancillary Data/Message Passing/Data Streaming Buffer Size (VIP_ANC_MSG_SIZE)	00000000h	Page 505
64h	--	Reserved	--	--
68h	R/W	VIP Page Offset/ Page Count (VIP_PAGE_OFFSET)	00000000h	Page 506
6Ch	R/W	VIP Vertical Start/Stop (VIP_VERT_START_STOP)	00000000h	Page 506
70h	R/W	VIP FIFO Address (VIP_FIFO_R_W_ADDR)	00000000h	Page 507
74h	R/W	VIP FIFO Data (VIP_FIFO_DATA)	xxxxxxxh	Page 507
78h	R/W	VIP VSYNC Error Count (VIP_SYNC_ERR_COUNT)	00000000h	Page 508
7Ch	R/W	VIP Task A U Even Offset (VIP_TASK_A_U_EVEN_OFFSET)	00000000h	Page 508
80h	R/W	VIP Task A V Even Offset (VIP_TASK_A_V_EVEN_OFFSET)	00000000h	Page 509

### 6.10.1 Standard GeodeLink™ Device (GLD) MSRs

#### 6.10.1.1 GLD Capabilities MSR (GLD\_MSR\_CAP)

MSR Address 54002000h  
 Type RO  
 Reset Value 00000000\_0003C4xxh

**GLD\_MSR\_CAP Register Map**

63	62	61	60	59	58	57	56	55	54	53	52	51	50	49	48	47	46	45	44	43	42	41	40	39	38	37	36	35	34	33	32
RSVD																															
31	30	29	28	27	26	25	24	23	22	21	20	19	18	17	16	15	14	13	12	11	10	9	8	7	6	5	4	3	2	1	0
NSMI				NCLK				DEV_ID														REV_ID									

**GLD\_MSR\_CAP Bit Descriptions**

Bit	Name	Description
63:32	RSVD	<b>Reserved.</b>
31:27	NSMI	<b>Number of SMI Registers.</b> The VIP generates 15 possible SMI interrupts.
26:24	NCLK	<b>Number of Clock Domains.</b> The VIP contains two clock domains; GLIU clock and VIP video clock.
23:8	DEV_ID	<b>Device ID.</b> Identifies device (03C4h).
7:0	REV_ID	<b>Revision ID.</b> Identifies device revision. See <i>AMD Geode™ LX Processors Specification Update</i> document for value.

#### 6.10.1.2 GLD Configuration MSR (GLD\_MSR\_CONFIG)

MSR Address 54002001h  
 Type R/W  
 Reset Value 00000000\_00000000h

**GLD\_MSR\_CONFIG Register Map**

63	62	61	60	59	58	57	56	55	54	53	52	51	50	49	48	47	46	45	44	43	42	41	40	39	38	37	36	35	34	33	32
RSVD																															
31	30	29	28	27	26	25	24	23	22	21	20	19	18	17	16	15	14	13	12	11	10	9	8	7	6	5	4	3	2	1	0
RSVD																					PRI1		RSVD	PRI0		RSVD	PID				

**GLD\_MSR\_CONFIG Bit Descriptions**

Bit	Name	Description
63:11	RSVD	<b>Reserved.</b>
10:8	PRI1	<b>Secondary Priority Level.</b> This value is the priority level the VIP uses when performing high priority GLIU accesses. This is the case when the FIFO is nearly full.
7	RSVD	<b>Reserved.</b>
6:4	PRI0	<b>Primary Priority Level.</b> This value is the priority level the VIP uses for most accesses (i.e., when the VIP FIFO is not in danger of being full).
3	RSVD	<b>Reserved.</b>
2:0	PID	<b>Priority ID.</b> This value is the priority ID (PID) value used when the VIP initiates GLIU transactions.

**6.10.1.3 GLD SMI MSR (GLD\_MSR\_SMI)**

MSR Address 54002002h  
 Type R/W  
 Reset Value 00000000\_ xxxx7FFFh

**GLD\_MSR\_SMI Register Map**

63	62	61	60	59	58	57	56	55	54	53	52	51	50	49	48	47	46	45	44	43	42	41	40	39	38	37	36	35	34	33	32
RSVD																															
31	30	29	28	27	26	25	24	23	22	21	20	19	18	17	16	15	14	13	12	11	10	9	8	7	6	5	4	3	2	1	0
RSVD	SMI_STATUS															RSVD	SMI_MASK														

**GLD\_MSR\_SMI Bit Descriptions**

Bit	Name	Description
63:31	RSVD	<b>Reserved.</b>
30:16	SMI_STATUS	<p><b>VIP SMI Interrupt Status.</b></p> <p>0: SMI not pending.            1: SMI pending.</p> <p>Writing a 1 to this bit clears the status:</p> <p>Bit 30: Reserved.            Bit 29: FIFO overflow error.            Bit 28: FIFO threshold hit.            Bit 27: Long line (&gt; 3000 clocks) error.            Bit 26: Vertical timing error.            Bit 25: Active pixels per line error.            Bit 24: VIP clock input error.            Bit 23: Ancillary packet checksum error.            Bit 22: Message buffer full or ancillary threshold packet count reached.            Bit 21: End of vertical blanking.            Bit 20: Start of vertical blanking.            Bit 19: Start of even field.            Bit 18: Start of odd field.            Bit 17: Current line = VIP Line Target (see Current/Target Line register).            Bit 16: GLIU Address or Type error.</p>
15	RSVD	<b>Reserved.</b>
14:0	SMI_MASK	<p><b>VIP SMI Masks.</b></p> <p>0: Enable, unmask the SMI.            1: Disabled, mask the SMI.</p> <p>Bit 14: Reserved.            Bit 13: FIFO overflow error.            Bit 12: FIFO threshold hit.            Bit 11: Long line (&gt; 3000 clocks) error.            Bit 10: Vertical timing error.            Bit 9: Active pixels per line error.            Bit 8: VIP clock input error.            Bit 7: Ancillary packet checksum error.            Bit 6: Message buffer full or ancillary threshold packet count reached.            Bit 5: End of vertical blanking.            Bit 4: Start of vertical blanking.            Bit 3: Start of even field.            Bit 2: Start of odd field.            Bit 1: Current line = VIP Line Target (see Current/Target Line register).            Bit 0: GLIU Address or Type error.</p>

**6.10.1.4 GLD Error MSR (GLD\_MSR\_ERROR)**

MSR Address 54002003h  
 Type R/W  
 Reset Value 00000000\_00000000h

**GLD\_MSR\_ERROR Register Map**

63	62	61	60	59	58	57	56	55	54	53	52	51	50	49	48	47	46	45	44	43	42	41	40	39	38	37	36	35	34	33	32
RSVD																															
31	30	29	28	27	26	25	24	23	22	21	20	19	18	17	16	15	14	13	12	11	10	9	8	7	6	5	4	3	2	1	0
RSVD														E1	E0	RSVD														EM1	EM0

**GLD\_MSR\_ERROR Bit Descriptions**

Bit	Name	Description
63:18	RSVD	<b>Reserved.</b>
17	E1	<b>Error Status 1.</b> Writing a 1 to this bit clears the status. 0: VIP error not pending. 1: VIP error pending. Types of Errors reported: Bit 17: Unexpected Address.
16	E0	<b>Error Status 0.</b> Writing a 1 to this bit clears the status. 0: VIP error not pending. 1: VIP error pending. Types of Errors reported: Bit 16: Unexpected Type.
15:2	RSVD	<b>Reserved.</b>
1	EM1	<b>Error Mask 1.</b> 0: Unmask the error (Enabled). 1: Mask the error (Disabled).
0	EM0	<b>Error Mask 0.</b> 0: Unmask the error (Enabled). 1: Mask the error (Disabled).

**6.10.1.5 GLD Power Management Register (GLD\_MSR\_PM)**

MSR Address 54002004h  
 Type R/W  
 Reset Value 00000000\_00000005h

**GLD\_MSR\_PM Register Map**

63	62	61	60	59	58	57	56	55	54	53	52	51	50	49	48	47	46	45	44	43	42	41	40	39	38	37	36	35	34	33	32
RSVD																															
31	30	29	28	27	26	25	24	23	22	21	20	19	18	17	16	15	14	13	12	11	10	9	8	7	6	5	4	3	2	1	0
RSVD																												0	P1	0	P0

**GLD\_MSR\_PM Bit Descriptions**

Bit	Name	Description
63:4	RSVD	<b>Reserved.</b>
3	RSVD	<b>Reserved.</b> Always set to 0.
2	P1	<b>VIP Clock Power Mode.</b> 0: Disable clock gating. VIP clock is always ON. 1: Enable active hardware clock gating.  The VIP input clock to the video input block is enabled when this bit is 0. When this bit is 1, the VIP input clock is enabled whenever the VIP reset bit (VIP Memory Offset 00h[0]) is 0 or if VIP_MODE (VIP Memory Offset 00h bit [3:1]) is in a non 000 state. This bit defaults to 1.
1	RSVD	<b>Reserved.</b> Always set to 0.
0	P0	<b>GLIU Clock Power Mode.</b> 0: Disable clock gating. GLIU clock is always ON. 1: Enable active hardware clock gating.  GLIU clock is always on if the VIP reset bit (VIP Memory Offset 00h[0]) is 0. When the VIP reset bit is 1 and this bit is 1, the internal VIP GLIU clocks are only turned on in response to requests (memory mapped read/writes and MSR read/writes) from the GLIU. This bit defaults to 1.

**6.10.1.6 GLD Diagnostic MSR (GLD\_MSR\_DIAG)**

MSR Address 54002005h  
 Type R/W  
 Reset Value 00000000\_00000000h

This register is reserved for internal use by AMD and should not be written to.

## 6.10.2 VIP Control/Configuration Registers

### 6.10.2.1 VIP Control Register 1 (VIP\_CTL\_REG1)

VIP Memory Offset 00h

Type R/W

Reset Value 42000001h

**VIP\_CTL\_REG1 Register Map**

31	30	29	28	27	26	25	24	23	22	21	20	19	18	17	16	15	14	13	12	11	10	9	8	7	6	5	4	3	2	1	0
ANC_FF		VID_FF				ERR_DETECT		NI	MB	DZ	DD	DT_EN						RUN_MODE		P	VIP_MODE		VPRST								

**VIP\_CTL\_REG1 Bit Descriptions**

Bit	Name	Description
31:29	ANC_FF	<p><b>Ancillary FIFO Flush.</b> Watermark level for flushing the 64-deep ancillary FIFO. This value determines how full the ancillary FIFO is before VIP starts writing QWORDS to system memory. If the FIFO has greater than 4 QWORDS and the address is aligned, VIP generates a burst (4 QWORDS) transaction. This value is reset to 2 (flush when 17 QWORDS).</p> <p>0: Flush when there is at least 1 QWORD.            1: Flush when there are at least 9 QWORDS.            2: Flush when there are at least 17 QWORDS. (Default)            n: Flush when there are at least <math>nx8 + 1</math> QWORDS (up to <math>n = 7x8 + 1 = 57</math>).            (ANC FIFO size is 64 QWORDS).</p>
28:24	VID_FF	<p><b>Video FIFO Flush.</b> Watermark level for flushing the 64-deep (planar mode) or 192-deep (linear mode) FIFO(s). This value determines how full the ancillary FIFO is before VIP starts writing QWORDS to system memory. If the FIFO has greater than 4 QWORDS and the address is aligned, VIP generates a burst (4 QWORDS) transaction. This value is reset to 2 (flush when 17 QWORDS).</p> <p>0: Flush when there is at least 1 QWORD.            1: Flush when there are at least 9 QWORDS.            2: Flush when there are at least 17 QWORDS. (Default)            n: Flush when there are at least <math>nx8+1</math> QWORDS.            (FIFO size is 192 QWORDS in Linear mode, maximum value is 17H/23d).            (FIFO size is 64 QWORDS in Planar mode, maximum value is 7).</p>
23:20	ERR_DETECT	<p><b>Video Detection Enable.</b> Selects what detection circuitry is used to detect loss of valid video input. When an error is detected, the video_ok output is set low. The associated interrupt pending bit must be cleared to allow the video_ok signal to return high.</p> <p>Bit 23: Runaway Line Error Abort (aborts line if a line is detected longer then 3000 clocks).</p> <p>Bit 22: Vertical Timing error (Vertical Count Register must be programmed) or addressing error (max_addr reg must be programmed).</p> <p>Bit 21: Number of clocks per active line error (checks that each line has the same # of data).</p> <p>Bit 20: Loss of VIP clock (watchdog timer using GLIU clocks --128 GLIU clocks).</p>



## VIP\_CTL\_REG1 Bit Descriptions (Continued)

Bit	Name	Description
19	NI	<p><b>Non-Interlaced Video Input.</b> This bit determines if the start/end-of-frame event occurs each field (for non-interlaced video) or at the end of the odd field (for interlaced video). The start/end-of-frame indication is used as the start/end-of-frame indication for the Run Mode Capture. When in 601 input modes, the NI bit determines if separate vertical back-porch values are used. For interlaced modes, different vertical start/end values can be programmed.</p> <p>0: Interlaced video (use FIELD and VBLANK flags for start/end-of-frame indication). 1: Non-Interlaced video (use only VBLANK flag for start/end-of-frame indication).</p>
18	MB	<p><b>Message/Streaming Control.</b></p> <p>0: Switch buffers each packet input or at end of buffer. 1: Switch buffers only when buffer is full. Store multiple packets in buffer.</p>
17	DZ	<p><b>Disable Zero Detect.</b> Disables ignoring zero data within SAV/EAV packets. When set, zero data is received and saved in system memory.</p> <p>0: Normal operation - Zero data in SAV/EAV packets is ignored and not saved to system memory. 1: Accept 0 data and save in system memory.</p>
16	DD	<p><b>Disable Decimation.</b> Disables decimation of even lines of Cr,Cb data for 4:2:2-&gt;4:2:0 translation.</p> <p>0: Normal operation - Even lines of Cr,Cb data do NOT get saved in Cr,Cb buffers when in planar mode. 1: All Cr,Cb data is stored in Cr,Cb main memory buffers.</p>
15:8	DT_EN	<p><b>Data Type Capture Enable.</b> (Only used when VIP_MODE (bits [3:1]) = 001, 010, 011)</p> <p>0: Disable capture data. 1: Enable capture data.</p> <p>Bit 8: Task A Video. Bit 9: Task A VBI. Bit 10: Task B Video. Bit 11: Task B VBI. Bit 12: Ancillary, Rising edge resets the ancillary packet count, the next packet will be stored starting at the base address. Bit 13: Reserved (always program to 0). Bit 14-15: Reserved (always program to 0).</p>
7:5	RUN_MODE	<p><b>Run Mode Capture.</b> Selects capture run mode.</p> <p>000: Stop capture. 001: Stop capture at end of the current line. 010: Stop capture at end of next field. 011: Stop capture at end of the next frame. 100: Start capture at beginning of next line. 101: Start capture at beginning of the next field. 110: Start capture at beginning of next frame. 111: Start capture (required for msg/data streaming modes).</p>
4	P	<p><b>Planar.</b> Determines if video data is stored in a linear format or planar format in system memory.</p> <p>0: Store data in linear format. 1: Store video data in planar format.</p>

## VIP\_CTL\_REG1 Bit Descriptions (Continued)

Bit	Name	Description
3:1	VIP_MODE	<b>VIP Operating Mode.</b> 000: IDLE. This mode forces VID[15:0] to 0 from pads to VIP. 001: VIP 2.0 8-bit mode. 010: VIP 2.0 16-bit. 011: VIP 1.1 8-bit. 100: Message Passing. 101: Data Streaming. 110: 601 type 8-bit mode. 111: 601 type 16-bit mode.
0	VRST	<b>VIP Reset.</b> When set to 1, this bit causes the VIP input logic to be reset. The control registers and base registers are not reset. Data is received/stored once this bit is set back to 0 according to Control Register 1 and 2. A 1 should also be written to the FIFO Reset (Control Register 3 (VIP Memory Offset 2Ch[0])) between writing a 1 and 0 to this register. The power-up value of VRST is 1.

## 6.10.2.2 VIP Control Register 2 (VIP\_CTL\_REG2)

VIP Memory Offset 04h

Type R/W

Reset Value 00000000h

## VIP\_CTL\_REG2 Register Map

31	30	29	28	27	26	25	24	23	22	21	20	19	18	17	16	15	14	13	12	11	10	9	8	7	6	5	4	3	2	1	0
FI	A_ERR_EN	R_EN	SWC	ANC10	ANCPEN	LPB	FF_R/W	PAGE_CNT				ANC_FF_THRESH				RSVD	VID_FF_THRESH				SYNC_TO_PIN			FIELD_TO_DC		SYNC_TO_DC					

## VIP\_CTL\_REG2 Bit Descriptions

Bit	Name	Description
31	FI	<b>Field Invert.</b> When set to 1, the polarity of the input field bit is inverted. This allows for devices that violate the VIP 2.0 specification.
30	A_ERR_EN	<b>Address Error Enable.</b> When set to 1, the GLIU address that VIP is writing to is compared to the Max Address register (VIP Memory Offset 14h). If a comparison is made, the VIP Run Mode control is forced to 0 causing VIP to stop capturing data. The frame error interrupt is generated.
29	R_EN	<b>Repeat Flag Enable.</b> When set to 1, the repeat flag in the SAV or EAV header is used to determine if the packet is saved. This allows the VIP to drop repeat fields during 3:2 pull down.
28	SWC	<b>Sub-Window Capture Enable.</b> When set to 1, only a portion of the frame/field is captured. Capture starts on the line specified in the Vertical Start/Stop register (VIP Memory Offset 6Ch) and ends after the line specified in the Vertical Start/Stop register.
27	ANC10	<b>10-bit Ancillary Data Input.</b> When set to 1, ancillary data is received as 10-bit data. (This is only applicable in 16-bit VIP mode).

## VIP\_CTL\_REG2 Bit Descriptions (Continued)

Bit	Name	Description
26	ANCPEN	<b>Ancillary Parity Check Enable.</b> When set to 1, ancillary DID, SDID, NN, and check sum bytes are checked for even parity. The error is reported on MSR 4002002h[23]. When this bit is 0, the Ancillary Checksum or Parity Error bit only indicates ancillary checksum errors.
25	LPB	<b>VOP to VIP Loopback.</b> When set to 1, the VOP clock and data are used as the clock and data inputs to the VIP. This allows for loopback testing of the VOP and VIP functions. This bit must be set to 0 for normal VIP operation.
24	FF_R/W	<b>FIFO R/W Enable.</b> When set to 1, the FIFO Address (VIP Memory Offset 70h) and FIFO Data (VIP Memory Offset 74h) registers can be used to write and read the 256x32 bit FIFO. This bit must be set to 0 for normal VIP operation.
23:21	PAGE_CNT	<b>Page Count.</b> Determines how many pages of video data are used. When this value is 000, a single page of video data is stored (Default). Additional pages are saved by adding the value in the Page Offset register (VIP Memory Offset 68h) to each base. 000: 1 Page. (Default) 001: 2 Pages. " 111: 8 Pages.
20:16	ANC_FF_THRESH	<b>Ancillary FIFO Threshold.</b> Watermark level for setting the ancillary FIFO threshold. This value also determines when the secondary priority is used during a write request. If the FIFO WORD count exceeds this value, the secondary priority ID is used. An INT or SMI can also be generated if this threshold is exceeded. Threshold value. 0-31. The Ancillary FIFO depth is always 64 QWORDS.
15	RSVD	<b>Reserved.</b>
14:8	VID_FF_THRESH	<b>Video FIFO Threshold.</b> Watermark level for setting the video FIFO threshold. This value also determines when the secondary priority is used during a write request. If the FIFO WORD count exceeds this value, the secondary priority ID is used. An INT or SMI can also be generated if this threshold is exceeded. Threshold value. 0-127 Linear mode: Y buffer depth is 192 QWORDS. Planar mode: Y,U,V buffer depths are all 64 QWORDS
7:5	SYNC_TO_PIN	<b>Sync Select.</b> Selects signal timing for VIP_VSYNC pin. 000: 0 (output disabled). 001: Select vsync_in from DC. 010: Select vsync_in from DC (inverted). 011: Select bit 17 of Status register (VIP Memory Offset 08h). 100-111: 0.
4:3	FIELD_TO_DC	<b>Field to DC Select.</b> Selects signal for field_to_vg. 00: Field input. 01: Inverted field input. 10: LSB of page being written (indicates which page is currently active). 11: Inverted LSB of page being written.
2:0	SYNC_TO_DC	<b>VSYNC Select.</b> Selects signal timing for VIP_VSYNC output to the DC. 000: Sync from pin. 001: Inverted sync from pin. 010: VBLANK. 011: Inverted VBLANK. 100: Field. 101: Inverted field. 110: When vip_current_line = target_line. 111: 0.

**6.10.2.3 VIP Status (VIP\_STATUS)**

VIP Memory Offset 08h

Type R/W

Reset Value xxxxxxxxh

**VIP\_STATUS Register Map**

31	30	29	28	27	26	25	24	23	22	21	20	19	18	17	16	15	14	13	12	11	10	9	8	7	6	5	4	3	2	1	0
APC								RSVD	FPE			RSVD	DPC	SO	BRNU	RSVD	MSG_BERR	B2_FULL	B1_FULL	RSVD			GLWC	FE	RSVD			F	V	RUN_STATUS	

**VIP\_STATUS Bit Descriptions**

Bit	Name	Description
31:24	APC (RO)	<b>Ancillary Packet Count (Read Only).</b> Number of ancillary packets available in the ancillary buffer in system memory. This count is incremented each time an ancillary packet is received. It gets decremented when a 1 is written to the DPC bit (bit 18).
23	RSVD	<b>Reserved.</b>
22:20	FPE (RO)	<b>FIFO Pointer Error (Read Only).</b> These bits indicate if the FIFO pointers are misaligned at the point when the base registers are updated. A 1 indicates that the pointers may be misaligned, which could result in an horizontal image shift. These bits are valid only when VBI data reception is disabled. INT15 is generated when any of these bits go active.  [22] - B FIFO. [21] - R FIFO. [20] - Y FIFO.
19	RSVD	<b>Reserved.</b>
18	DPC (WO)	<b>Decrement Ancillary Packet Count (Write Only).</b> Writing a 1 to this bit causes the ancillary packet count to be decremented by 1.
17	SO (WO)	<b>Sync Out (Write Only).</b> Writing a 1 to this bit causes a 0-1-0 transition on the VIP_VSYNC pin (32 GLIU clocks).
16	BRNU (RO)	<b>Base Register Not Updated (Read Only).</b>  0: All base registers are updated. 1: One or more of the base registers have been written but have not yet been updated. <b>Note:</b> The following base registers are updated at a start-of-frame event.  TASK_A_VID_EVEN_BASE, TASK_A_VID_ODD_BASE, TASK_A_VBI_EVEN_BASE, TASK_A_VID_ODD_BASE, TASK_A_VID_EVEN_BASE, TASK_A_VID_ODD_BASE, TASK_A_VBI_EVEN_BASE, TASK_A_VID_ODD_BASE  The start-of-frame event occurs when entering a vertical blanking interval during the Odd field (for interlaced video) or when entering any vertical blanking interval (non-interlaced video). Since the base pointers are initialized to 0 at reset, a start-of-frame event <b>MUST</b> occur before enabling VIP to receive data. Otherwise, VIP will save the first video frame to address 0 in system memory. One way of insuring this is to initialize VIP to receive video data with the RUN_MODE bits (VIP Memory Offset 00h bits [7:5]) set to 0. This enables the VIP input interface, but it will not capture video. Poll this bit until the internal base register updates have occurred. The RUN_MODE control can then be programmed to start capturing data on the next line/field/frame boundary.
15	RSVD	<b>Reserved.</b>

## VIP\_STATUS Bit Descriptions (Continued)

Bit	Name	Description
14	MSG_BERR	<b>Message Buffer Error.</b> 0: No error. 1: Message buffer was overwritten. This occurs when both msg buffers are full and a msg/dstrm packet is received. Writing a 1 to the bit resets it to 0.
13	B2_FULL	<b>MSG Buffer 2 Full.</b> 0: Buffer 2 empty. 1: Buffer 2 full. Writing a 1 to the bit resets it to 0.
12	B1_FULL	<b>MSG Buffer 1 Full.</b> 0: Buffer 1 empty. 1: Buffer 1 full. Writing a 1 to the bit resets it to 0.
11:10	RSVD	<b>Reserved.</b>
9	GLWC	<b>GLIU Writes Completed.</b> 0: VIP has outstanding GLIU transactions. 1: VIP has completed all outstanding GLIU transactions.
8	FE	<b>VIP FIFO Empty.</b> 0: VIP FIFO is NOT empty. 1: VIP FIFO is empty.
7:5	RSVD	<b>Reserved.</b>
4	F (RO)	<b>Field Indication (Read Only).</b> Indicates current status of field being received. 0: Odd field is being received. 1: Even field is being received.
3	V (RO)	<b>VBLANK Indication (Read Only).</b> Indicates current status of VBLANK being received. 0: Active video. 1: Vertical blanking.
2:0	Run Status (RO)	<b>Run Status (Read Only).</b> Indicates active data types received. Bit 2: Indicates that an ancillary packet has been received. Bit 1: Indicates that a VBI packet has been received. Bit 0: Indicates that a video packet or Msg/Data Streaming packet has been received. Writing a 1 to a bit resets it to 0. These bits are enabled when the corresponding DT_EN bits are set in the VIP Control 1 register (VIP Memory Offset 00h) along with the VIP_MODE bits.

**6.10.2.4 VIP Interrupt (VIP\_INT)**

VIP Memory Offset 0Ch

Type R/W

Reset Value xxxxFFFEh

**VIP\_INT Register Map**

31	30	29	28	27	26	25	24	23	22	21	20	19	18	17	16	15	14	13	12	11	10	9	8	7	6	5	4	3	2	1	0
INT_STATUS																INT_MASK															

**VIP\_INT Bit Descriptions**

Bit	Name	Description
31:16	INT_STATUS	<p><b>VIP Interrupt Status.</b></p> <p>0: INT not pending. 1: INT pending.</p> <p>Writing a 1 to this bit clears the status.</p> <p>Bit 30: FIFO line wrap error. Bit 29: FIFO overflow error. Bit 28: FIFO threshold hit. Bit 27: Long line (&gt; 3000 clocks) error. Bit 26: Vertical timing error (frame error or address error)/Msg missed error. Bit 25: Active pixels per line error. Bit 24: VIP clock input error. Bit 23: Ancillary checksum or parity error. Bit 22: Msg buffer full or ancillary threshold packet count reached. Bit 21: End of vertical blanking. Bit 20: Start of vertical blanking. Bit 19: Start of even field. Bit 18: Start of odd field. Bit 17: Current line = VIP Line Target (see Current/Target Line register). Bit 16: Not used (0).</p>
15:0	INT_MASK	<p><b>VIP Interrupt Masks.</b></p> <p>0: Enable, unmask the INT. 1: Disabled, mask the INT.</p> <p>Bit 14: When enabled (0), allows FIFO line wrap error INT. Bit 13: When enabled (0), allows FIFO overflow error INT. Bit 12: When enabled (0), allows FIFO threshold hit INT. Bit 11: When enabled (0), allows Long line (&gt; 3000 clocks) error INT. Bit 10: When enabled (0), allows vertical timing error (frame error or address error) INT. Bit 9: When enabled (0), allows the active pixel input video error INT. Bit 8: When enabled (0), allows the VIP clock input error INT. Bit 7: When enabled (0), allows ancillary checksum or parity error INT. Bit 6: When enabled (0), allows msg buffer full INT or ancillary threshold packet count reached INT. Bit 5: When enabled (0), allows end of vertical blanking INT. Bit 4: When enabled (0), allows start of vertical blanking INT. Bit 3: When enabled (0), allows start of even field INT. Bit 2: When enabled (0), allows start of odd field INT. Bit 1: When enabled (0), allows current line = VIP Line Target INT (see Current/Target Line register). Bit 0: Not used (R/W).</p>

**6.10.2.5 VIP Current/Target (VIP\_CUR\_TAR)**

VIP Memory Offset 10h

Type R/W

Reset Value 00000000h

**VIP\_CUR\_TAR Register Map**

31	30	29	28	27	26	25	24	23	22	21	20	19	18	17	16	15	14	13	12	11	10	9	8	7	6	5	4	3	2	1	0
LINE_TARGET																CURRENT_LINE															

**VIP\_CUR\_TAR Register Bit Descriptions**

Bit	Name	Description
31:16	LINE_TARGET	<b>Line Target.</b> Indicates the video line to generate an interrupt on.
15:0	CURRENT_LINE (RO)	<b>Current Line (Read Only).</b> Indicates the video line currently being captured. Line counting begins on the first active line. The count indicated in this field is reset to 0 at the start of each field (interlaced) or frame (non-interlaced).

**6.10.2.6 VIP Max Address (VIP\_MAX\_ADDR)**

VIP Memory Offset 14h

Type R/W

Reset Value FFFFFFFFh

**VIP\_MAX\_ADDR Register Map**

31	30	29	28	27	26	25	24	23	22	21	20	19	18	17	16	15	14	13	12	11	10	9	8	7	6	5	4	3	2	1	0
MAX_ADDR																												RSVD			

**VIP\_MAX\_ADDR Bit Descriptions**

Bit	Name	Description
31:3	MAX_ADDR	<b>Max Address.</b> This value is compared with the GLIU address. If the GLIU address is equal or greater than this value, a VIP addressing error is detected. This resets the RUN_MODE bits (VIP Memory Offset 00h[7:5]) to 000, stopping the VIP from capturing data. A frame error INT is also generated. The A_ERR_EN bit (VIP Memory Offset 04h[30]) must be set to enable this function. The VIP must be reset by writing a 1 to the VRST bit (VIP Memory Offset 00h[0]) to clear the addressing error. Bits [2:0] of this register are not used in the comparison. Note that the VIP will only stop capturing data on this address, it will continue writing data from the FIFO into memory. Up to 192 QWORDS (1536 bytes) can be written past this address (max # data in FIFO, although it is more likely that ~10-20 QWORDS are written).
2:0	RSVD	<b>Reserved.</b> Set to 0.

**6.10.2.7 VIP Task A Video Even Base Address (VIP\_TASK\_A\_VID\_EVEN\_BASE)**

VIP Memory Offset 18h

Type R/W

Reset Value 00000000h

**VIP\_TASK\_A\_VID\_EVEN\_BASE Register Map**

31	30	29	28	27	26	25	24	23	22	21	20	19	18	17	16	15	14	13	12	11	10	9	8	7	6	5	4	3	2	1	0
TASK_A_VIDEO_EVEN_BASE_ADDRESS																											Program to 00000				

**VIP\_TASK\_A\_VID\_EVEN\_BASE Bit Descriptions**

Bit	Name	Description
31:0	TASK_A_VIDEO_EVEN_BASE	<p><b>Task A Video Even Base Address.</b> This register specifies the base address in graphics memory where Task A even video field data will be stored. Changes to this register take effect at the beginning of the next field. This value needs to be 32-byte aligned. (Bits [4:0] are required to be 00000.)</p> <p><b>Note:</b> This register is double buffered. When a new value is written to this register, the new value is placed in a special pending register, and the Base Register Not Updated bit (VIP Memory Offset 08h[16]) is set to 1. The Task A Video Data Even Base Address register is not updated at this point. When the first data of the next field is captured, the pending values of all base registers are written to the appropriate base registers, and the Base Register Not Updated bit is cleared.</p>

**6.10.2.8 VIP Task A Video Odd Base Address (VIP\_TASK\_A\_VID\_ODD\_BASE)**

VIP Memory Offset 1Ch

Type R/W

Reset Value 00000000h

**VIP\_TASK\_A\_VID\_ODD\_BASE Register Map**

31	30	29	28	27	26	25	24	23	22	21	20	19	18	17	16	15	14	13	12	11	10	9	8	7	6	5	4	3	2	1	0
TASK_A_VIDEO_ODD_BASE																											Program to 00000				

**VIP\_TASK\_A\_VID\_ODD\_BASE Bit Descriptions**

Bit	Name	Description
31:0	TASK_A_VIDEO_ODD_BASE	<p><b>Task A Video Odd Base Address.</b> This register specifies the base address in graphics memory where Task A odd video field data will be stored. Changes to this register take effect at the beginning of the next field. This value needs to be 32-byte aligned. (Bits [4:0] are required to be 00000.)</p> <p><b>Note:</b> This register is double buffered. When a new value is written to this register, the new value is placed in a special pending register, and the Base Register Not Updated bit (VIP Memory Offset 08h[16]) is set to 1. The Task A Video Data Odd Base Address Register is not updated at this point. When the first data of the next field is captured, the pending values of all base registers are written to the appropriate base registers, and the Base Register Not Updated bit is cleared.</p>



**6.10.2.9 VIP Task A VBI Even Base Address (VIP\_TASK\_A\_VBI\_EVEN\_BASE)**

VIP Memory Offset 20h

Type R/W

Reset Value 00000000h

**VIP\_TASK\_A\_VBI\_EVEN\_BASE Register Map**

31	30	29	28	27	26	25	24	23	22	21	20	19	18	17	16	15	14	13	12	11	10	9	8	7	6	5	4	3	2	1	0
TASK_A_VBI_DATA_EVEN_BASE																										Program to 00000					

**VIP\_TASK\_A\_VBI\_EVEN\_BASE Bit Descriptions**

Bit	Name	Description
31:0	TASK_A_VBI_EVEN_BASE	<p><b>Task AVBI Even Base Address.</b> This register specifies the base address in graphics memory where VBI data for even fields is stored. Changes to this register take effect at the beginning of the next field. The value in this register is 16-byte aligned. This value needs to be 32-byte aligned. (Bits [4:0] are required to be 00000.)</p> <p><b>Note:</b> This register is double buffered. When a new value is written to this register, the new value is placed in a special pending register, and the Base Register Not Updated bit (VIP Memory Offset 08h[16]) is set to 1. The Task A VBI Even Base Address register is not updated at this point. When the first data of the next field is captured, the pending values of all base registers are written to the appropriate base registers, and the Base Register Not Updated bit is cleared.</p>

**6.10.2.10 VIP Task A VBI Odd Base Address (VIP\_TASK\_A\_VBI\_ODD\_BASE)**

VIP Memory Offset 24h

Type R/W

Reset Value 00000000h

**VIP\_TASK\_A\_VBI\_ODD\_BASE Register Map**

31	30	29	28	27	26	25	24	23	22	21	20	19	18	17	16	15	14	13	12	11	10	9	8	7	6	5	4	3	2	1	0
TASK_A_VBI_DATA_ODD_BASE																										Program to 00000					

**VIP\_TASK\_A\_VBI\_ODD\_BASE Bit Description**

Bit	Name	Description
31:0	TASK_A_VBI_ODD_BASE	<p><b>Task A VBI Odd Base Address.</b> This register specifies the base address in graphics memory where Task A VBI data for odd fields are stored. Changes to this register take effect at the beginning of the next field. The value in this register is 8-byte aligned. This value needs to be 32-byte aligned. (Bits [4:0] are required to be 00000.)</p> <p><b>Note:</b> This register is double buffered. When a new value is written to this register, the new value is placed in a special pending register, and the Task A Base Register Not Updated bit (VIP Memory Offset 08h[16]) is set to 1. The Task A VBI Odd Base Address register is not updated at this point. When the first data of the next field is captured, the pending values of all base registers are written to the appropriate base registers, and the Base Register Not Updated bit is cleared.</p>

**6.10.2.11 VIP Task A Video Pitch (VIP\_TASK\_A\_VID\_PITCH)**

VIP Memory Offset 28h

Type R/W

Reset Value 00000000h

**VIP\_TASK\_A\_VID\_PITCH Register Map**

31	30	29	28	27	26	25	24	23	22	21	20	19	18	17	16	15	14	13	12	11	10	9	8	7	6	5	4	3	2	1	0
TASK_A_UV_PITCH											Program to 00000						TASK_A_VIDEO_PITCH						Program to 00000								

**VIP\_TASK\_A\_VID\_PITCH Bit Descriptions**

Bit	Name	Description
31:16	TASK_A_UV_PITCH	<b>Task A UV Pitch.</b> Specifies the logical width of the video data buffer when in linear mode. Specifies the logical width of the U and V buffers when in planar mode. This value is added to the start of the line address to get the address of the next line where captured video data will be stored. This value must be an integral number of QWORDS. This value needs to be 32-byte aligned. (Bits [20:16] are required to be 00000.)
15:0	TASK_A_VIDEO_PITCH	<b>Task A Video Pitch.</b> Specifies the logical width of the video data buffer when in linear mode. Specifies the logical width of the Y buffer when in planar mode. This value is added to the start of the line address to get the address of the next line where captured video data will be stored. This value must be an integral number of QWORDS. This value needs to be 32-byte aligned. (Bits [4:0] are required to be 00000.)

**6.10.2.12 VIP Control Register 3 (VIP\_CONTRL\_REG3)**

VIP Memory Offset 2Ch

Type R/W

Reset Value 00000020h

**VIP\_CONTRL\_REG3 Register Map**

31	30	29	28	27	26	25	24	23	22	21	20	19	18	17	16	15	14	13	12	11	10	9	8	7	6	5	4	3	2	1	0			
RSVD																					PDM	BRU	DOR	EFD	TP	VP	HP	RSVD						EF

**VIP\_CONTRL\_REG3 Bit Descriptions**

Bit	Name	Description
31:11	RSVD	<b>Reserved.</b>
10	PDM	<b>Planar De-interlace Mode.</b> When set to 1, the U/V even buffers are referenced to the Task A Video Odd Base Address (VIP Memory Offset 18h) rather than the Task A Video Even Base Address (VIP Memory Offset 1Ch). This bit should always be set to 0. (Possibly used in some de-interlacing schemes, but not likely.)
9	BRU	<b>Base Register Update.</b> When set to 1, base registers are updated at the beginning of each field when in interlaced mode. When 0, the base registers are updated at the beginning of each frame when in interlaced mode. This bit has no effect in non-interlaced mode where start of field is the same as start of frame.
8	DOR	<b>Disable Overflow Recovery.</b> When set to 1, the overflow recovery logic is disabled. An overflow interrupt is generated. It is then up to the software to do a FIFO reset to recover from the overflow condition

## VIP\_CONTRL\_REG3 Bit Descriptions (Continued)

Bit	Name	Description
7	EFD	<b>Even Field UV Decimation.</b> When set to 1, the U and V values of the even frame will be discarded. <b>Note:</b> The DD bit (VIP Memory Offset 00h[16]) should be set to 1 or even lines will also be decimated.
6	TP	<b>Task Polarity.</b> When set to 1, the input TASK bit is inverted.
5	VP	<b>VSYNC Polarity.</b> This bit is set to 1 when the VSYNC input is active high (high during VBLANK) or 0 when the VSYNC input is active low (low during VBLANK). This is only used for 601 type input video where HSYNC and VSYNC signals are used rather than the SAV/EAV codes.
4	HP	<b>HSYNC Polarity.</b> This bit is set to 1 when the HSYNC input is active high (high during HBLANK) or 0 when the HSYNC input is active low (low during HBLANK). This is only used for 601 type input video where HSYNC and VSYNC signals are used rather than the SAV/EAV codes.
3:1	RSVD	<b>Reserved.</b>
0	FR	<b>FIFO Reset.</b> Setting this bit forces the VIP FIFO pointers and data counts to their reset state. This might be used in cases where high GLIU latencies cause continuous FIFO overflows, when a line overrun error occurs, or if the line offset gets corrupted which could result in an image shift. This bit remains a 1 during the FIFO reset sequence. When the FIFO reset sequence has completed, this bit is automatically reset to a 0.  The FIFO reset sequence consists of: Input reception is halted. The input and output FIFO addresses and data counts are reset. Wait for all outstanding GLIU requests to be completed. The FIFO Reset bit is set to 0.  Input data reception starts after the programmed run control event has occurred (i.e., start of line, field, frame).

## 6.10.2.13 VIP Task A V Offset (VIP\_TASK\_A\_V\_OFFSET)

VIP Memory Offset 30h

Type R/W

Reset Value 00000000h

## VIP\_TASK\_A\_V\_OFFSET Register Map

31	30	29	28	27	26	25	24	23	22	21	20	19	18	17	16	15	14	13	12	11	10	9	8	7	6	5	4	3	2	1	0
TASK_A_V_ODD_OFFSET																											Program to 00000				

## VIP\_TASK\_A\_V\_OFFSET Bit Descriptions

Bit	Name	Description
31:0	TASK_A_V_ODD_OFFSET	<b>Task A V Odd Offset.</b> This register determines the starting address of the V buffer when data is stored in planar format. The start of the V buffer is determined by adding the contents of this register to that of the base address. This value must be 32-byte aligned. (Bits [4:0] are required to be 00000.)

**6.10.2.14 VIP Task A U Offset (VIP\_TASK\_A\_U\_OFFSET)**

VIP Memory Offset 34h

Type R/W

Reset Value 00000000h

**VIP\_TASK\_A\_U\_OFFSET Register Map**

31	30	29	28	27	26	25	24	23	22	21	20	19	18	17	16	15	14	13	12	11	10	9	8	7	6	5	4	3	2	1	0
Task A U Odd Offset																										Program to 00000					

**VIP\_TASK\_A\_U\_OFFSET Bit Descriptions**

Bit	Name	Description
31:0	Task A U Odd Offset	<b>Task A U Odd Offset.</b> This register determines the starting address of the U buffer when data is stored in planar format. For interlaced input, this register will determine the starting address of the U data for the odd field. The start of the U buffer is determined by adding the contents of this register to that of the base address. This value needs to be 32-byte aligned. (Bits [4:0] are required to be 00000.)

**6.10.2.15 VIP Task B Video Even Base/Horizontal End (VIP\_TASK\_B\_VID\_EVEN\_BASE\_HORIZ\_END)**

VIP Memory Offset 38h

Type R/W

Reset Value 00000000h

**VIP\_TASK\_B\_VID\_EVEN\_BASE\_HORIZ\_END Register Map**

31	30	29	28	27	26	25	24	23	22	21	20	19	18	17	16	15	14	13	12	11	10	9	8	7	6	5	4	3	2	1	0
TASK_B_VID_EVEN_BASE_HORIZ_END (601 type modes)																															

**VIP\_TASK\_B\_VID\_EVEN\_BASE\_HORIZ\_END Bit Descriptions**

Bit	Name	Description
31:0	TASK_B_VID_EVEN_BASE	<b>Task B Video Even Base Address.</b> This register specifies the base address in graphics memory where even video field data are stored. Changes to this register take effect at the beginning of the next field. The value in this register is 16-byte aligned. Bits [3:0] are always 0, and define the required address space.  <b>Note:</b> This register is double buffered. When a new value is written to this register, the new value is placed in a special pending register, and the Base Register Not Updated bit (VIP Memory Offset 08h[16]) is set to 1. The Task B Video Even Base Address register is not updated at this point. When the first data of the next field is captured, the pending values of all base registers are written to the appropriate base registers, and the Base Register Not Updated bit is cleared.
15:0	HORIZ_END	<b>Horizontal End.</b> This register is redefined in BT.601 mode. In BT. 601 type input modes timing is derived from the external HSYNC and VSYNC inputs. This value specifies where video data ends for the line.

**6.10.2.16 VIP Task B Video Odd Base/Horizontal Start (VIP\_TASK\_B\_VID\_ODD\_BASE\_HORIZ\_START)**

VIP Memory Offset 3Ch

Type R/W

Reset Value 00000000h

**VIP\_TASK\_B\_VID\_ODD\_BASE\_HORIZ\_START Register Map**

31	30	29	28	27	26	25	24	23	22	21	20	19	18	17	16	15	14	13	12	11	10	9	8	7	6	5	4	3	2	1	0
TASK_B_VID_ODD_BASE_HORIZ_START (601 type modes)																															

**VIP\_TASK\_B\_VID\_ODD\_BASE\_HORIZ\_START Bit Descriptions**

Bit	Name	Description
31:0	TASK_B_VID_ODD_BASE	<p><b>Task B Video Odd Base Address.</b> This register specifies the base address in graphics memory where odd video field data is stored. Changes to this register take effect at the beginning of the next field. This value must be 32-byte aligned. (Bits[4:0] are required to be 00000.)</p> <p><b>Note:</b> This register is double buffered. When a new value is written to this register, the new value is placed in a special pending register, and the “Base Register Not Updated” bit (VIP Memory Offset 08h[16]) is set to 1. The Video Data Odd Base Address register is not updated at this point. When the first data of the next field is captured, the pending values of all base registers are written to the appropriate base registers, and the Base Register Not Updated bit is cleared.</p>
11:0	HORIZ_START	<p><b>Horizontal Start.</b> This register is redefined in BT.601 mode. In BT.601 type input modes timing is derived from the external HSYNC and VSYNC inputs. This value specifies where video data starts for the line. See Figure 6-47 "BT.601 Mode Horizontal Timing" on page 472 for programing information.</p>

**6.10.2.17 VIP Task B VBI Even Base/VBI End (VIP\_TASK\_B\_VBI\_EVEN\_BASE\_VBI\_END)**

VIP Memory Offset 40h

Type R/W

Reset Value 00000000h

**VIP\_TASK\_B\_VBI\_EVEN\_BASE\_VBI\_END Register Map**

31	30	29	28	27	26	25	24	23	22	21	20	19	18	17	16	15	14	13	12	11	10	9	8	7	6	5	4	3	2	1	0
TASK_B_VBI_DATA_EVEN_BASE_VBI_END (for 601 type modes)																															

**VIP\_TASK\_B\_VBI\_EVEN\_BASE\_VBI\_END Bit Descriptions**

Bit	Name	Description
31:0	TASK_B_VBI_DATA_EVEN_BASE_VBI_END	<p><b>Task B VBI Even Base Address.</b> This register specifies the base address in graphics memory where VBI data for even fields is stored. Changes to this register take effect at the beginning of the next field. This value must be 32-byte aligned. (Bits [4:0] are required to be 00000.)</p> <p><b>Note:</b> This register is double buffered. When a new value is written to this register, the new value is placed in a special pending register, and the Base Register Not Updated bit (VIP Memory Offset 08h[16]) is set to 1. The VBI Odd Base Address register is not updated at this point. When the first data of the next field is captured, the pending values of all base registers are written to the appropriate base registers, and the VBI Base Register Not Updated bit is cleared.</p>

**VIP\_TASK\_B\_VBI\_EVEN\_BASE\_VBI\_END Bit Descriptions (Continued)**

Bit	Name	Description
11:0	VBI_END	<b>VBI End.</b> This register is redefined in BT.601 mode. In BT.601 type input modes, timing is derived from the external HSYNC and VSYNC inputs. This value specifies what line the VBI data ends in each field/frame. The end of VBI data is reached when the number of lines from the falling edge of VSYNC equals this value. See Figure 6-48 "BT.601 Mode Vertical Timing" on page 473 for additional detail.

**6.10.2.18 VIP Task B VBI Odd Base/VBI Start (VIP\_TASK\_B\_VBI\_ODD\_BASE\_VBI\_START)**

VIP Memory Offset 44h

Type R/W

Reset Value 00000000h

**VIP\_TASK\_B\_VBI\_ODD\_BASE\_VBI\_START Register Map**

31	30	29	28	27	26	25	24	23	22	21	20	19	18	17	16	15	14	13	12	11	10	9	8	7	6	5	4	3	2	1	0
TASK_B_VBI_DATA_ODD_BASE_VBI_START (for 601 type modes)																															

**VIP\_TASK\_B\_VBI\_ODD\_BASE\_VBI\_START Bit Descriptions**

Bit	Name	Description
31:0	TASK_B_VBI_DATA_ODD_BASE	<b>Task B VBI Odd Base Address.</b> This register specifies the base address in graphics memory where VBI data for odd fields is stored. Changes to this register take effect at the beginning of the next field. This value must be 32-byte aligned. (Bits [4:0] are required to be 00000.)  <b>Note:</b> This register is double buffered. When a new value is written to this register, the new value is placed in a special pending register, and the Base Register Not Updated bit (VIP Memory Offset 08h[16]) is set to 1. The VBI Odd Base Address register is not updated at this point. When the first data of the next field is captured, the pending values of all base registers are written to the appropriate base registers, and the VBI Base Register Not Updated bit is cleared.
11:0	VBI_START	<b>VBI Start.</b> This register is redefined in BT.601 mode. In BT.601 type input modes, timing is derived from the external HSYNC and VSYNC inputs. This value specifies what line the VBI data starts in each field/frame. The start of VBI data begins when the number of lines from the leading edge of VSYNC equals this value. See Figure 6-48 "BT.601 Mode Vertical Timing" on page 473 for additional detail.

**6.10.2.19 VIP Task B Data Pitch/Vertical Start Even (VIP\_TASK\_B\_DATA\_PITCH\_VERT\_START\_EVEN)**

VIP Memory Offset 48h

Type R/W

Reset Value 00000000h

**VIP\_TASK\_B\_DATA\_PITCH\_VERT\_START\_EVEN Register Map**

31	30	29	28	27	26	25	24	23	22	21	20	19	18	17	16	15	14	13	12	11	10	9	8	7	6	5	4	3	2	1	0
RSVD				VERTICAL_END_EVEN												TASK_B_DATA_PITCH_VERT_START_EVEN															

**VIP\_TASK\_B\_DATA\_PITCH\_VERT\_START\_EVEN BIT Descriptions**

Bit	Name	Description
31:28	RSVD	<b>Reserved.</b>

## VIP\_TASK\_B\_DATA\_PITCH\_VERT\_START\_EVEN BIT Descriptions (Continued)

Bit	Name	Description
27:16	VERTICAL_END_EVEN (even/second field)	<b>Vertical End Even.</b> This register is redefined in BT.601 mode. In BT.601 type input modes timing is derived from the external HSYNC and VSYNC inputs. This value specifies the last line of the even field captured in interlaced modes. This value is ignored when the NI bit (VIP Memory Offset 00h[19]) is set (indicating non-interlaced input). The VERT_END (VIP Memory Offset 6Ch[27:16]) value is used for non-interlaced modes. See Figure 6-48 "BT.601 Mode Vertical Timing" on page 473 for additional detail.
15:0	TASK_B_DATA_PITCH	<b>Task B Data Pitch/.</b> Specifies the logical width of the video data buffer. This value is added to the start of the line address to get the address of the next line where captured video data will be stored. The value in this register needs to be 32-byte aligned in linear mode, and 64-byte aligned in planar mode. (In linear mode, bits [4:0] are required to be 00000. In planar mode, bits [5:0] are required to be 000000.)
11:0	VERT_START_EVEN (even/second field)	<b>Vertical Start Even.</b> This register is redefined in BT.601 mode. In BT.601 type input modes, timing is derived from the external HSYNC and VSYNC inputs. This value specifies the line that the even field video data begins. Even field video data is captured until Vertical End Even This value is ignored when the NI bit (VIP Memory Offset 00h[19]) is set (indicating non-interlaced input). The VERT_START (VIP Memory Offset 6Ch) value is used for non-interlaced modes. See Figure 6-48 "BT.601 Mode Vertical Timing" on page 473 for additional detail.

## 6.10.2.20 VIP Task B V Offset (VIP\_TASK\_B\_V\_Offset)

VIP Memory Offset 50h

Type R/W

Reset Value 00000000h

## VIP\_TASK\_B\_V\_OFFSET Register Map

31	30	29	28	27	26	25	24	23	22	21	20	19	18	17	16	15	14	13	12	11	10	9	8	7	6	5	4	3	2	1	0
TASK_B_V_OFFSET_START_ODD																															

## VIP\_TAS\_B\_V\_OFFSET Bit Descriptions

Bit	Name	Description
31:0	TASK_B_V_OFFSET	<b>Task B V Offset.</b> This register determines the starting address of the V buffer when data is stored in planar format. The start of the V buffer is determined by adding the contents of this register to that of the base address. The value in this register needs to be 32-byte aligned. (Bits [4:0] are required to be 00000.)  <b>Note:</b> This register is NOT double buffered and should be initialized before start of video capture.
11:0 23:16	START_ODD	<b>Start Odd Field Detect/Duration.</b> This register is redefined in BT.601 mode. When in BT.601 interlaced mode, this register determines the window for field detection. The Start bits [11:0] are the number of clocks from the leading edge of HSYNC to when the detection window begins, the duration bits [23:16] are the # of clocks that the detection window is active. If the leading edge of VSYNC occurs within the window, the field is set to odd, otherwise it is set to even. At the default state of 0, the leading edge of VBLANK must transition simultaneously with the leading edge of HSYNC for odd field detection. When the NI bit in (VIP Memory Offset 00h[19]) is set (non-interlaced mode), all frames are considered to be odd fields.

**6.10.2.21 VIP Task B U Offset (VIP\_TASK\_B\_U\_OFFSET)**

VIP Memory Offset 54h

Type R/W

Reset Value 00000000h

**VIP\_TASK\_B\_U\_OFFSET Register Map**

31	30	29	28	27	26	25	24	23	22	21	20	19	18	17	16	15	14	13	12	11	10	9	8	7	6	5	4	3	2	1	0
TASK_B_U_OFFSET																											Program to 00000				

**VIP\_TASK\_B\_U\_OFFSET Bit Descriptions**

Bit	Name	Description
31:0	TASK_B_U_OFFSET	<p><b>Task B U Offset.</b> This register determines the starting address of the U buffer when data is stored in planar format. The start of the U buffer is determined by adding the contents of this register to that of the base address. The value in this register must be 32-byte aligned. (Bits [4:0] are required to be 00000.)</p> <p><b>Note:</b> This register is NOT double buffered and should be initialized before start of video capture.</p>

**6.10.2.22 VIP Ancillary Data/Message Passing/Data Streaming Buffer1 Base Address (VIP\_ANC\_MSG\_1\_BASE)**

VIP Memory Offset 58h

Type R/W

Reset Value 00000000h

**VIP\_ANC\_MSG\_1\_BASE Register Map**

31	30	29	28	27	26	25	24	23	22	21	20	19	18	17	16	15	14	13	12	11	10	9	8	7	6	5	4	3	2	1	0
ANC_MSG_1_BASE																											Program to 00000				

**VIP\_ANC\_MSG\_1\_BASE Bit Descriptions**

Bit	Name	Description
31:0	ANC_MSG_1_BASE	<p><b>Ancillary Data/Message Passing Data/Data Streaming Base Address.</b> This register specifies the base address for the ancillary data when in VIP modes or message/streaming data when in Message Passing or Data Streaming modes. Changes to this register take effect at the beginning of the next field when in VIP mode. It takes place immediately when in Message Passing or Data Streaming mode. The value in this register must be 32-byte aligned. (Bits [4:0] are required to be 00000.)</p> <p><b>Note:</b> This register is NOT double buffered.</p>



**6.10.2.23 VIP Ancillary Data/Message Passing/Data Streaming Buffer 2 Base Address (VIP Anc\_Msg\_2\_Base)**

VIP Memory Offset 5Ch

Type R/W

Reset Value 00000000h

**VIP Anc\_Msg\_2\_Base Register Map**

31	30	29	28	27	26	25	24	23	22	21	20	19	18	17	16	15	14	13	12	11	10	9	8	7	6	5	4	3	2	1	0
ANC_MSG_2_BASE																											Program to 00000				

**VIP Anc\_Msg\_2\_Base Bit Descriptions**

Bit	Name	Description
31:0	ANC_MSG_2_BASE	<b>Message Passing Data/Data Streaming Base Address.</b> This register specifies the base address for the second buffer used in Message Passing and Data Streaming modes. Data written to this register takes place immediately (no double buffer). The value in this register must be 32-byte aligned. (Bits [4:0] are required to be 00000.) <b>Note:</b> This register is NOT double buffered.

**6.10.2.24 VIP Ancillary Data/Message Passing/Data Streaming Buffer Size (VIP Anc\_Msg\_Size)**

VIP Memory Offset 60h

Type R/W

Reset Value 00000000h

**VIP Anc\_Msg\_Size Register Map**

31	30	29	28	27	26	25	24	23	22	21	20	19	18	17	16	15	14	13	12	11	10	9	8	7	6	5	4	3	2	1	0
ANC_PACK_INT_THRESH								RSVD				ANC_MSG_STREAM_SIZE																			

**VIP Anc\_Msg\_Size Bit Descriptions**

Bit	Name	Description
31:24	ANC_PACK_INT_THRESH	<b>Ancillary Packet Interrupt Threshold Value.</b> This value determines when the ancillary interrupt occurs. The Ancillary Packet Count (APC) bits (VIP Memory Offset 08h[31:24]) is compared to this value. If the APC is equal to or greater than this value, the ancillary interrupt is generated.
23:19	RSVD	<b>Reserved.</b>
18:0	ANC_MSG_STREAM_SIZE	<b>Ancillary Data/Message Passing Data/Data Streaming Buffer Size.</b> This register specifies the size of the ancillary, message passing, and data streaming buffers in bytes. Changes to this register take effect immediately (not double buffered). The value in this register is 8-byte aligned. Bits [2:0] are ignored.

**6.10.2.25 VIP Page Offset/ Page Count (VIP\_PAGE\_OFFSET)**

VIP Memory Offset 68h

Type R/W

Reset Value 00000000h

**VIP\_PAGE\_OFFSET Register Map**

31	30	29	28	27	26	25	24	23	22	21	20	19	18	17	16	15	14	13	12	11	10	9	8	7	6	5	4	3	2	1	0
PAGE_OFFSET																											Program to 00000				

**VIP\_PAGE\_OFFSET Bit Descriptions**

Bit	Name	Description
31:0	PAGE_OFFSET	<b>Page Offset.</b> This register specifies the offset to the next page of buffer data. If the page count is 2 or greater, the next frame of data is started at an address of buffer + PAGE_OFFSET. Up to eight pages (frames) can be accumulated. The address of the next frame is located at a "Page Offset" address. Note that ancillary data and MSG/STRM data is not paged. This only applies to video and VBI data. The value in this register needs to be 32-byte aligned. (Bits [4:0] are required to be 00000.)

**6.10.2.26 VIP Vertical Start/Stop (VIP\_VERT\_START\_STOP)**

VIP Memory Offset 6Ch

Type R/W

Reset Value 00000000h

**VIP\_VERT\_START\_STOP Register Map**

31	30	29	28	27	26	25	24	23	22	21	20	19	18	17	16	15	14	13	12	11	10	9	8	7	6	5	4	3	2	1	0
RSVD				VERT_END								RSVD				VERT_START															

**VIP\_VERT\_START\_STOP Bit Description**

Bit	Name	Description
31:28	RSVD	<b>Reserved.</b> Set to 0.
27:16	VERT_END	<b>Vertical End Capture.</b> This register specifies the last line # in a field/frame that is captured when the subwindow capture function is enabled in non BT.601 modes. In BT.601 interlaced modes, this register determines when the odd field line capture completes. In 601 non-interlaced modes, this register determines when the video capture completes. See Figure 6-48 "BT.601 Mode Vertical Timing" on page 473 for additional detail.
15:12	RSVD	<b>Reserved.</b> Set to 0.
11:0	VERT_START	<b>Vertical Start Capture.</b> This register specifies the first line # in a field/frame that is captured when the subwindow capture function is enabled in non 601 modes. In BT.601 interlaced modes, this register determines when the odd field video capture starts. In BT.601 non-interlaced modes, this register determines when the video capture starts. See Figure 6-48 "BT.601 Mode Vertical Timing" on page 473 for additional detail.

**6.10.2.27 VIP FIFO Address (VIP\_FIFO\_R\_W\_ADDR)**

VIP Memory Offset 70h

Type R/W

Reset Value 00000000h

**VIP\_FIFO\_R\_W\_ADDR Register Map**

31	30	29	28	27	26	25	24	23	22	21	20	19	18	17	16	15	14	13	12	11	10	9	8	7	6	5	4	3	2	1	0
RSVD																FIFO_ADDRESS															

**VIP\_FIFO\_R\_W\_ADDR Bit Descriptions**

Bit	Name	Description
31:9	RSVD	<b>Reserved.</b> Set to 0.
8:0	FIFO_ADDRESS	<b>FIFO ADDRESS.</b> FIFO address for which a FIFO read or write occurs. The data is written/read via the FIFO Data register (VIP Memory Offset 74h). Note that the 256x64 bit FIFO is mapped as a 512x32 bit memory.

**6.10.2.28 VIP FIFO Data (VIP\_FIFO\_DATA)**

VIP Memory Offset 74h

Type R/W

Reset Value xxxxxxxxh

**VIP\_FIFO\_DATA Register Map**

31	30	29	28	27	26	25	24	23	22	21	20	19	18	17	16	15	14	13	12	11	10	9	8	7	6	5	4	3	2	1	0
FIFO_DATA																															

**VIP\_FIFO\_DATA Bit Descriptions**

Bit	Name	Description
31:0	FIFO_DATA	<b>FIFO Data.</b> When the FF_R/W bit is set (VIP Memory Offset 04h[24] = 1), data written to this register is stored in FIFO_ADDR (VIP Memory Offset 70h[7:0]). When the FF_R/W bit is reset, data from the FIFO corresponding to the address in the FIFO_ADDR is returned

**6.10.2.29 VIP VSYNC Error Count (VIP\_SYNC\_ERR\_COUNT)**

VIP Memory Offset 78h

Type R/W

Reset Value 00000000h

**VIP\_SYNC\_ERR\_COUNT Register Map**

31	30	29	28	27	26	25	24	23	22	21	20	19	18	17	16	15	14	13	12	11	10	9	8	7	6	5	4	3	2	1	0
VERTICAL_WINDOW								VERTICAL_COUNT																							

**VIP\_SYNC\_ERR\_COUNT Bit Descriptions**

Bit	Name	Description
31:24	VERTICAL_WINDOW	<b>Vertical Window.</b> This field defines the number of VIP clocks the input VBLANK can vary before it is considered invalid. (16-4095 clocks)
23:0	VERTICAL_COUNT	<b>Vertical Count.</b> This field provides the check point for verifying that the input data stream is maintaining consistent VSYNC timing. This count is the minimum number of VIP clocks expected in an input field (interlaced video) or frame (non-interlaced video). If the number of video clocks between rising edges of VBLANK is less then this number (or greater then VERTICAL_COUNT + VERTICAL_WINDOW), a VSYNC error interrupt is generated and the video_ok output signal is forced low indicating invalid input video. (0-16,777,215 clocks)  <b>Note:</b> A 60 Hz VBLANK rate @75 MHz input clock = 1,250,000 clocks.

**6.10.2.30 VIP Task A U Even Offset (VIP\_TASK\_A\_U\_EVEN\_OFFSET)**

VIP Memory Offset 7Ch

Type R/W

Reset Value 00000000h

**VIP\_TASK\_A\_U\_EVEN\_OFFSET Register Map**

31	30	29	28	27	26	25	24	23	22	21	20	19	18	17	16	15	14	13	12	11	10	9	8	7	6	5	4	3	2	1	0
TASK_A_U_EVEN_OFFSET																											Program to 00000				

**VIP\_TASK\_A\_U\_EVEN\_OFFSET Bit Descriptions**

Bit	Name	Description
31:0	TASK_A_U_EVEN_OFFSET	<b>Task A U Even Offset.</b> This register determines the starting address of the U buffer for the even field when in interlaced input mode and data is stored in planar format. This register is not used when in non-interlaced input mode. The value in this register needs to be 32-byte aligned. (Bits [4:0] are required to be 00000.)

**6.10.2.31 VIP Task A V Even Offset (VIP\_TASK\_A\_V\_EVEN\_OFFSET)**

VIP Memory Offset 80h

Type R/W

Reset Value 00000000h

**VIP\_TASK\_A\_V\_EVEN\_OFFSET Register Map**

31	30	29	28	27	26	25	24	23	22	21	20	19	18	17	16	15	14	13	12	11	10	9	8	7	6	5	4	3	2	1	0
TASK_A_V_EVEN_OFFSET																												Program to 00000			

**VIP\_TASK\_A\_V\_EVEN\_OFFSET Bit Descriptions**

Bit	Name	Description
31:0	TASK_A_V_EVEN_OFFSET	<b>Task A V Even Offset.</b> This register determines the starting address of the V buffer for the even field when in interlaced input mode and data is stored in planar format. This register is not used when in non-interlaced input mode. The value in this register needs to be 32-byte aligned. (Bits [4:0] are required to be 00000.)

## 6.11 Security Block

The Security Block provides a hardware Advanced Encryption Standard (AES) encryption/decryption engine and interface for accessing EEPROM memory for storing unique IDs and/or security keys. The AES and EEPROM sections have separate control registers but share a single set of interrupt registers.

- Programmable “Hidden” AES key
- Can use interrupts, SMLs, or be polled for completion status
- Memory mapped register interface

- True Random Number Generator (TRNG)
  - Read via MSR

**Note:** For security purposes, the EEPROM interface resets to the “debug disabled” state. It takes approximately 490 us to read the EEPROM and unlock the debug interface. Therefore, the “CPU stall” feature must be available even when the debug interface is disabled. Since the EEPROM may not respond for up to 10 ms after a write operation, the time out for accessing the EEPROM is set to approximately 17 ms. Therefore it takes approximately 17 ms for a part without an EEPROM to unlock after the release from reset.

### 6.11.1 Security Block Features

- AES
  - Electronic Code Book (ECB) or Cipher Block Chaining (CBC) 128-bit hardware encryption and decryption
  - CBC 128-bit hardware encryption and decryption
  - DMA read and write (two contexts)
  - Hidden key, (stored on EEPROM)
  - Writable key can be written by the x86 processor
  - Can use interrupts, SMLs, or be polled for completion status
  - Memory mapped register interface
- EEPROM I/F
  - Provides 2K bit of EEPROM storage
  - Programmable lock bits

#### 6.11.1.1 Performance Metrics

- System goals:
  - 400 MHz GLIU interface
  - > 40 MB/Sec. encrypt or decrypt

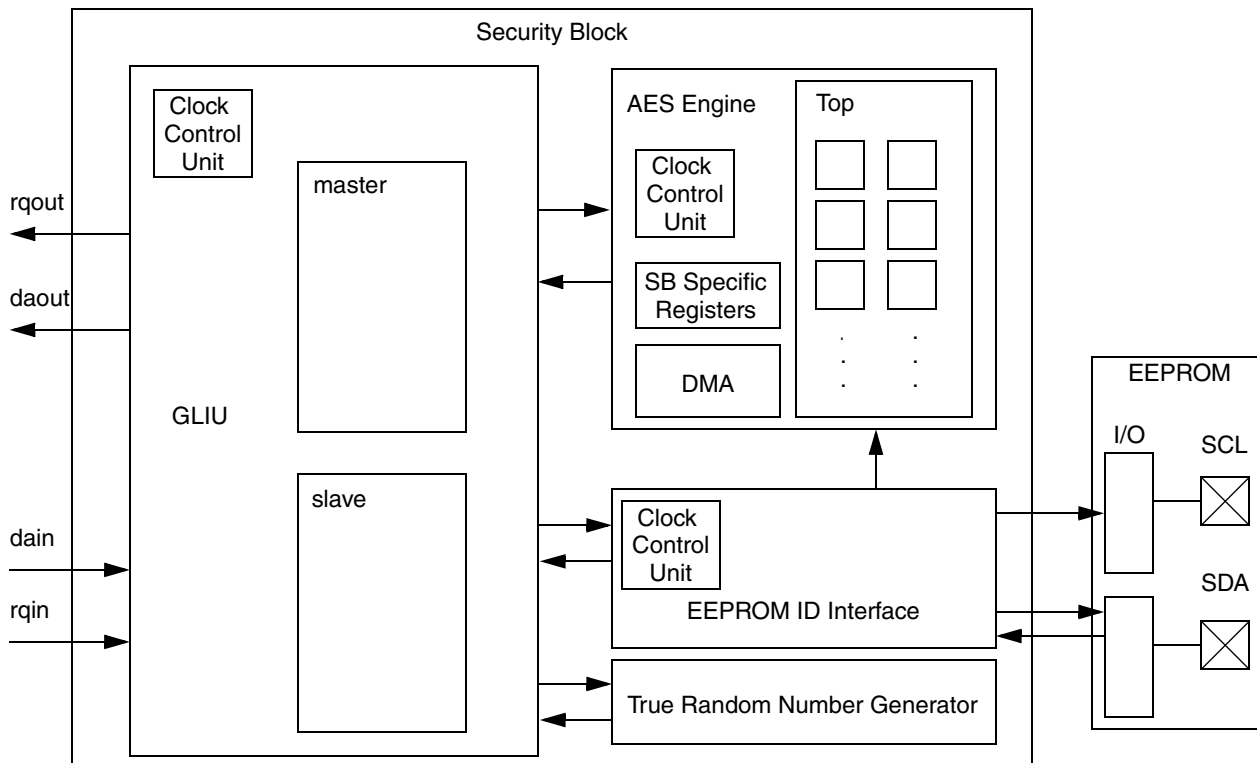


Figure 6-54. Security Block Diagram

### 6.11.2 Functional Description

The AES engine provides ECB and CBC 128-bit hardware encryption and decryption for the AMD Geode LX processor using the Advanced Encryption Standard algorithm.

The Security Block has two key sources. One is a hidden 128-bit key stored in non-volatile memory. It is expected that this key is loaded into the non-volatile memory once at the factory and the memory is locked to prevent future writes. This key is loaded automatically by hardware after reset and is not visible to the x86 processor, (also, these locations in non-volatile memory cannot be read using the non-volatile memory interface). The second key is writable, (but not readable) by the x86 processor. It appears as a series of four writable 32-bit QWORDS in the Security Block memory address space. Reads to these registers always return zeros. Note that these bits are accessible via the debug interface unless the debug interface has been locked.

For any single operation, the Security Block can work in either encryption or decryption mode. The same two key registers (hidden and writable) are used for both modes.

The Security Block provides a mastering DMA interface to system memory. It contains two sets of pointer registers (contexts A and B) for controlling the DMA operations. For each set, there is a 32-bit DMA Source register that points to the start of the source data in memory. The lower four LSBs are zero, forcing the address to align to a 16-byte boundary. There is a 32-bit DMA Destination register that points to the region in memory where the AES block writes its results. This pointer also forces alignment to a 16-byte boundary. For consistency with other block architecture specifications, these registers are described as QWORDS in the Security Block memory space. In addition to the 32-bit DMA Source register, there is a 32-bit Length register that holds a count of the number of bytes to be encrypted/decrypted. Again the lower four bits are zero forcing the length to be an integer multiple of 16-byte blocks. If the source data does not end on a 16-byte boundary, software must pad the data out to the next 16-byte boundary. Having two separate contexts allows the software to queue a second encryption/decryption request while the first operation is completing. The Security Block only contains a single AES hardware block so the second request is not processed until the first request completes.

The Control registers (SB Memory Offset 00h and 04h) are used to configure the Security Block. There are two sets of control bits to select the key source (hidden vs. writable) and the operational mode (encryption/decryption), and the data coherency flags for memory accesses. There are also two start bits (A and B) to initiate an operation once the appropriate pointers have been configured. The Security Block can be configured to generate an interrupt on completion of an encryption/decryption operation. Alternatively, the interrupt can be masked and the completion bit can be polled.

For each start command, the Security Block processes the data starting at the DMA source address and continues for the number of bytes specified in the Length register. The results are written starting at the address in the Destination register. For each start command, the Security Block processes the data starting at the DMA source address and continues for the number of bytes specified in the Length register. The results are written starting at the address in the Destination register. For each start command, the AES can be configured for key source, encryption/decryption mode, and memory coherence flags. No changes to the A registers should be made during an encryption or decryption operation for A, and no changes to the B registers should be made during an encryption or decryption operation for B. In CBC mode, the CBC Initialization Vector register value is used by both A and B channels.

The AMD Geode LX processor supports AES CBC mode and a True Random Number Generator. CBC encryption/decryption is similar to ECB. When doing CBC mode encryption/decryption, the 128-bit initialization vector is written to the CBC Initialization Vector registers (SB Memory Offset 40h-4Ch) prior to the start of the encryption/decryption. The random number generator function provides true random numbers required for the initialization values for AES CBC encryption. Software must read the 32-bit random number register four times to build the 128-bit initialization vector (IV). This can then be used to program the CBC Initialization Vector registers prior to the CBC encryption.

### 6.11.2.1 EEPROM ID Interface

The EEPROM ID interface provides an interface to an EEPROM non-volatile memory available for storing ID numbers, keys, or other security related information. The EEPROM ID interface consists of a 2K (256-byte) array with 2 bytes reserved for EEPROM control state, 238 bytes are available as general purpose non-volatile storage, and 16 bytes reserved for use as a hidden key for the AES engine. (Note that locations 18-33 are reserved for a Unique ID, but can be used for general purpose storage.)

After reset, the EEPROM ID interface state machine reads the two access control bytes from the EEPROM. These define the access policies for the EEPROM. It also automatically copies the 128-bit hidden key from the array to the AES engine's hidden key register. When an AMD Geode LX processor device is initially manufactured, the EEPROM is programmed to all ones and the control bytes are set to the unlocked state allowing writing of the entire EEPROM array and reading of all location except the hidden key. Information can be stored in the EEPROM and then optionally the EEPROM can be locked to prevent further writes and/or disable certain debug features of the AMD Geode LX processor.

The EEPROM controller defaults to the unlocked state if it cannot access an EEPROM after reset. This allows parts built without EEPROMs to have functional debug interfaces.

The EEPROM ID interface works on a byte-wide basis. The EEPROM Address register (SB Memory Offset 804h) is first programmed by software, and then the EEPROM Command register (SB Memory Offset 804h) is written to initiate a write from the EEPROM Data register (SB Mem-

ory Offset 808h) to the array or a read from the array to the Data register. The START bit in the Command register (SB Memory Offset 800h) resets automatically once the EEPROM access has completed. The user may also enable an interrupt to be generated when the access has completed. Since the EEPROM access is slow, this simple command interface allows the processor to continue with other tasks while waiting for the access to complete. Table 6-77 shows common usage of the EEPROM.

**Note:** The EEPROM interface is designed to work with a GLIU frequency up to 400 MHz. For operation above 400 MHz, several internal design parameters must be changed.

### 6.11.2.2 Security Block Interrupts

The Security Block has three possible sources for an interrupt: completion of an AES task on context A, completion of an AES task on context B, and completion of an EEPROM read or write operation. The interrupt event and interrupt mask registers are memory mapped. These three sources can also generate an SMI. The SMI event and SMI mask registers are accessible via MSRs. Any one of these events will simultaneously set the SMI and interrupt event bits. The mask bits may be used to enable either an interrupt or an SMI if desired.

### 6.11.2.3 GLIU Interface

The GLIU provides a standard interface to the AMD Geode LX processor. The Security Block is both a master and a slave on this bus.

**Table 6-77. EEPROM Address Map**

Byte Address	Range	Description
0	Lower	Access control byte 0 (WPU and WPL)
1		Access control byte 1 (WPE and DBL)
2-17		Hidden key storage (128 bits)
18-33		Unique ID (128 bits)
34-127		User data
128-255	Upper	User data



## 6.12 Security Block Register Descriptions

This section provides information on the registers associated with the Security Block (SB), including the Standard GeodeLink Device (GLD) MSRs, the Security Block Specific MSRs (accessed via the RDMSR and WRMSR instructions), and the Security Block Configuration/Control registers. Table 6-78 through Table 6-80 are register summary

tables that include reset values and page references where the bit descriptions are provided.

The MSR address is derived from the perspective of the CPU Core. See Section 4.1 "MSR Set" on page 45 for more detail on MSR addressing.

**Table 6-78. Standard GeodeLink™ Device MSRs Summary**

MSR Address	Type	Register Name	Reset Value	Reference
58002000h	RO	GLD Capabilities MSR (GLD_MSR_CAP)	00000000_001304xxh	Page 515
58002001h	R/W	GLD Master Configuration MSR (GLD_MSR_CONFIG)	00000000_00000000h	Page 515
58002002h	R/W	GLD SMI MSR (GLD_MSR_SMI)	00000000_00000007h	Page 516
58002003h	R/W	GLD Error MSR (GLD_MSR_ERROR)	00000000_00000019h	Page 516
58002004h	R/W	GLD Power Management MSR (GLD_MSR_PM)	00000000_00000015h	Page 518
58002005h	R/W	GLD Diagnostic MSR (GLD_MSR_DIAG)	00000000_00000000h	Page 518

**Table 6-79. Security Block Specific MSRs**

MSR Address	Type	Register Name	Reset Value	Reference
58002006h	R/W	GLD Control MSR (GLD_MSR_CTRL)	00000000_00000003h	Page 519

**Table 6-80. Security Block Configuration/Control Registers Summary**

SB Memory Offset	Type	Register Name	Reset Value	Reference
000h	R/W	SB Control A (SB_CTL_A)	00000000h	Page 520
004h	R/W	SB Control B (SB_CTL_B)	00000000h	Page 521
008h	R/W	SB AES Interrupt (SB_AES_INT)	00000007h	Page 522
010h	R/W	SB Source A (SB_SOURCE_A)	00000000h	Page 522
014h	R/W	SB Destination A (SB_DEST_A)	00000000h	Page 523
018h	R/W	SB Length A (SB_LENGTH_A)	00000000h	Page 523
020h	R/W	SB Source B (SB_SOURCE_B)	00000000h	Page 524
024h	R/W	SB Destination B (SB_DEST_B)	00000000h	Page 524
028h	R/W	SB Length B (SB_LENGTH_B)	00000000h	Page 525
030h	WO	SB Writable Key 0 (SB_WKEY_0)	00000000h	Page 525
034h	WO	SB Writable Key 1 (SB_WKEY_1)	00000000h	Page 526
038h	WO	SB Writable Key 2 (SB_WKEY_2)	00000000h	Page 526
03Ch	WO	SB Writable Key 3 (SB_WKEY_3)	00000000h	Page 527
040h	R/W	SB CBC Initialization Vector 0 (SB_CBC_IV_0)	00000000h	Page 527
044h	R/W	SB CBC Initialization Vector 1 (SB_CBC_IV_1)	00000000h	Page 528

**Table 6-80. Security Block Configuration/Control Registers Summary (Continued)**

SB Memory Offset	Type	Register Name	Reset Value	Reference
048h	R/W	SB CBC Initialization Vector 2 (SB_CBC_IV_2)	00000000h	Page 528
04Ch	R/W	SB CBC Initialization Vector 3 (SB_CBC_IV_3)	00000000h	Page 528
050h	RO	SB Random Number (SB_RANDOM_NUM)	00000000h	Page 529
054h	RO	SB Random Number Status (SB_RANDOM_NUM_STATUS)	00000001h	Page 529
800h	R/W	SB EEPROM Command (SB_EEPROM_COMM)	00000000h	Page 530
804h	R/W	SB EEPROM Address (SB_EEPROM_ADDR)	000000FFh	Page 531
808h	R/W	SB EEPROM Data (SB_EEPROM_DATA)	00000000h	Page 531
80Ch	RO	SB EEPROM Security State (SB_EEPROM_SEC_STATE)	00000000h	Page 532

## 6.12.1 Standard GeodeLink™ (GLD) Device MSRs

### 6.12.1.1 GLD Capabilities MSR (GLD\_MSR\_CAP)

MSR Address 58002000h  
 Type RO  
 Reset Value 00000000\_001304xxh

**GLD\_MSR\_CAP Register Map**

63	62	61	60	59	58	57	56	55	54	53	52	51	50	49	48	47	46	45	44	43	42	41	40	39	38	37	36	35	34	33	32
RSVD																															
31	30	29	28	27	26	25	24	23	22	21	20	19	18	17	16	15	14	13	12	11	10	9	8	7	6	5	4	3	2	1	0
RSVD								DEV_ID														REV_ID									

**GLD\_MSR\_CAP Bit Descriptions**

Bit	Name	Description
63:24	RSVD	Reserved.
23:8	DEV_ID	<b>Device ID.</b> Identifies device (1304h).
7:0	REV_ID	<b>Revision ID.</b> Identifies device revision. See <i>AMD Geode™ LX Processors Specification Update</i> document for value.

### 6.12.1.2 GLD Master Configuration MSR (GLD\_MSR\_CONFIG)

MSR Address 58002001h  
 Type R/W  
 Reset Value 00000000\_00000000h

**GLD\_MSR\_CONFIG Register Map**

63	62	61	60	59	58	57	56	55	54	53	52	51	50	49	48	47	46	45	44	43	42	41	40	39	38	37	36	35	34	33	32
RSVD																															
31	30	29	28	27	26	25	24	23	22	21	20	19	18	17	16	15	14	13	12	11	10	9	8	7	6	5	4	3	2	1	0
RSVD																								PRI		RSVD	PID				

**GLD\_MSR\_CONFIG Bit Descriptions**

Bit	Name	Description
63:7	RSVD	Reserved.
6:4	PRI	<b>AES Priority Level.</b> This is the Priority level used by the AES interface.
3	RSVD	Reserved.
2:0	PID	<b>AES Priority Domain.</b> Assigned priority domain identifier.

**6.12.1.3 GLD SMI MSR (GLD\_MSR\_SMI)**

MSR Address 58002002h  
 Type R/W  
 Reset Value 00000000\_00000007h

**GLD\_MSR\_SMI Register Map**

63	62	61	60	59	58	57	56	55	54	53	52	51	50	49	48	47	46	45	44	43	42	41	40	39	38	37	36	35	34	33	32
RSVD																												SMI_STAT US			
31	30	29	28	27	26	25	24	23	22	21	20	19	18	17	16	15	14	13	12	11	10	9	8	7	6	5	4	3	2	1	0
RSVD																												SMI_MASK			

**GLD\_MSR\_SMI Bit Descriptions**

Bit	Name	Description
63:35	RSVD	<b>Reserved.</b>
34:32	SMI_STATUS	<p><b>SMI Status.</b> There are three SMI status sources. For each source, the individual bit has the following meaning:</p> <p>0: SMI not pending.                      1: SMI pending.</p> <p>Writing a 1 to the bit clears the status.</p> <p>Bit 34: EEPROM Operation Complete SMI.                      Bit 33: AES Context B Complete SMI.                      Bit 32: AES Context A Complete SMI.</p>
31:3	RSVD	<b>Reserved.</b>
2:0	SMI_MASK	<p><b>SMI Masks.</b> There are three SMI status masks. For each source, the individual bit has the following meaning:</p> <p>0: Enable. Unmask the SMI.                      1: Disable. Mask the SMI.</p> <p>Bit 2: When enabled (0), allows EEPROM Operation Complete SMI.                      Bit 1: When enabled (0), allows AES Context B Complete SMI.                      Bit 0: When enabled (0), allows AES Context A Complete SMI.</p>

**6.12.1.4 GLD Error MSR (GLD\_MSR\_ERROR)**

MSR Address 58002003h  
 Type R/W  
 Reset Value 00000000\_00000019h

## GLD\_MSR\_ERROR Register Map

63	62	61	60	59	58	57	56	55	54	53	52	51	50	49	48	47	46	45	44	43	42	41	40	39	38	37	36	35	34	33	32
RSVD																											RB_ERR_STATUS	RA_ERR_STATUS	RSVD	AES_ERR_STATUS	
31	30	29	28	27	26	25	24	23	22	21	20	19	18	17	16	15	14	13	12	11	10	9	8	7	6	5	4	3	2	1	0
RSVD																											RB_ERR_MASK	RA_ERR_MASK	RSVD	AES_ERR_MASK	

## GLD\_MSR\_Error Bit Descriptions

Bit	Name	Description
63:37	RSVD	<b>Reserved.</b>
36	RB_ERR_STATUS	<b>Response B Error Status.</b> When set, this bit indicates that context B received a response with either the SSMI or Exception flag set. This can occur on any of the read responses or on the last write of an encrypt or decrypt operation that also requires a response. If the error occurs on a read response, the operation is terminated and the state machine returns to idle and signals completion. Write a one to this bit to clear the status.
35	RA_ERR_STATUS	<b>Response A Error Status.</b> When set, this bit indicates that context A received a response with either the SSMI or Exception flag set. This can occur on any of the read responses or on the last write of an encrypt or decrypt operation that also requires a response. If the error occurs on a read response, the operation is terminated and the state machine returns to idle and signals completion. Write a one to this bit to clear the status.
34-33	RSVD	<b>Reserved.</b>
32	AES_ERR_STATUS	<b>AES Error Status.</b> Reserved Type. This bit is set if the module receives a transaction identified with a reserved transaction type. This implies a hardware error. 0: AES Error not pending. 1: AES Error pending. Writing a 1 to this bit clears the status.
31:3	RSVD	<b>Reserved.</b>
4	RB_ERR_MASK	<b>Response B Error Mask.</b> When set, this bit masks the Response B Error (bit 36) and prevents generation of the error output. When cleared, the error is enabled and assertion of Response B Error will generate an error.
3	RA_ERR_MASK	<b>Response A Error Mask.</b> When set, this bit masks the Response A Error (bit 35) and prevents generation of the error output. When cleared, the error is enabled and assertion of Response A Error will generate an error.
2:1	RSVD	<b>Reserved.</b>
0	AES_ERR_MASK	<b>AES Error Mask.</b> Reserved Type. 0: Unmask the Error (enabled). 1: Mask the Error (disabled).

**6.12.1.5 GLD Power Management MSR (GLD\_MSR\_PM)**

MSR Address 58002004h  
 Type R/W  
 Reset Value 00000000\_00000015h

**GLD\_MSR\_PM Register Map**

63	62	61	60	59	58	57	56	55	54	53	52	51	50	49	48	47	46	45	44	43	42	41	40	39	38	37	36	35	34	33	32
RSVD																															
31	30	29	28	27	26	25	24	23	22	21	20	19	18	17	16	15	14	13	12	11	10	9	8	7	6	5	4	3	2	1	0
RSVD																											PMD2	RSVD	PMD1	RSVD	PMD0

**GLD\_MSR\_PM Bit Descriptions**

Bit	Name	Description
63:5	RSVD	<b>Reserved.</b>
4	PMD2	<b>Power Mode 2 (EEPROM).</b> 0: Disable clock gating. Clocks are always ON. 1: Enable active hardware clock gating.
3	RSVD	<b>Reserved.</b>
2	PMD1	<b>Power Mode 1 (AES core, GLIU clock/2).</b> 0: Disable clock gating. Clocks are always ON. 1: Enable active hardware clock gating.
1	RSVD	<b>Reserved.</b>
0	PMD0	<b>Power Mode 0 (GLIU clock).</b> 0: Disable clock gating. Clocks are always ON. 1: Enable active hardware clock gating.

**6.12.1.6 GLD Diagnostic MSR (GLD\_MSR\_DIAG)**

MSR Address 58002005h  
 Type R/W  
 Reset Value 00000000\_00000000h

This register is reserved for internal use by AMD and should not be written to.

## 6.12.2 Security Block Specific MSRs

### 6.12.2.1 GLD Control MSR (GLD\_MSR\_CTRL)

MSR Address 58002006h  
 Type R/W  
 Reset Value 00000000\_00000003h

**GLD\_MSR\_CTRL Register Map**

63	62	61	60	59	58	57	56	55	54	53	52	51	50	49	48	47	46	45	44	43	42	41	40	39	38	37	36	35	34	33	32
RSVD																															
31	30	29	28	27	26	25	24	23	22	21	20	19	18	17	16	15	14	13	12	11	10	9	8	7	6	5	4	3	2	1	0
RSVD																				T_TM	T_NE	T_SEL	RSVD			TW	SBY	SBI	DIV		

**GLD\_MSR\_CTRL Bit Descriptions**

Bit	Name	Description
63:12	RSVD	<b>Reserved.</b> These bits are implemented but reserved for future use. When writing to this MSR, software should set these bits to 0 and ignore them on read.
11	T_TM	<b>TRNG Test Mode.</b> This bit enables the TRNG test mode. Deterministic TRNG values are generated when this bit is 1.
10	T_NE	<b>TRNG Noise Enable.</b> This bit enables the noise generator for the TRNG. 0: Disable. 1: Enable.
9:8	T_SEL	<b>TRNG SEL.</b> These bits select post processing of the TRNG output. 00: Raw output. 01: LFSR output. 10: Whitener output. 11: LFSR + Whitener output.
7:5	RSVD	<b>Reserved.</b> These bits are implemented but reserved for future use. When writing to this MSR, software should set these bits to 0 and ignore them on read.
4	TW	<b>Time Write.</b> This bit controls the EEPROM write timing within the EEPROM interface module. Normally the EEPROM interface signals completion immediately after it finishes shifting out the last bit of a write operation. The start of any other EEPROM access begins a polling process. Once, the EEPROM has completed its internally timed write operation, it responds to the polling and the next operation can begin. Setting this bit causes the EEPROM interface to delay for slightly more than 10 ms after writing to the EEPROM, before indicating write completion. That is, the start bit will be held high, and the interrupt and SMI generation will be delayed for 10 ms. This ensures that the EEPROM has completed its internal write and should be ready to respond to the next access immediately. This is a “chicken” bit to avoid using the acknowledge polling (as described in the Atmel datasheet), after a write.
3	SBY	<b>Swap Bytes.</b> This bit controls a byte-swapping feature within the AES module. When set, the bytes within the 16-byte block are swapped on both AES DMA reads and writes. Byte 15 is swapped with byte 0, byte 14 is swapped with byte 1, etc. Asserting this bit does not affect the slave operations to AES registers, (including the writable key), nor does it affect EEPROM operations. When this bit is cleared, the DMA operations read and write bytes with the same byte order as they appear in memory.

## GLD\_MSR\_CTRL Bit Descriptions (Continued)

Bit	Name	Description
2	SBI	<b>Swap Bits.</b> This bit controls a bit-swapping feature within the AES module. When set, the bits within each byte are swapped on both AES DMA reads and writes. Bit 7 is swapped with bit 0, bit 6 is swapped with 1, etc. Asserting this bit does not affect the slave operations to AES registers, (including the writable key), nor does it affect EEPROM operations. When this bit is cleared, the DMA operations read and write bytes with the same bit order as they appear in memory.
1:0	DIV	<b>AES Enable Divider.</b> These two bits control the ratio between the GLIU clock frequency and the updating of the AES encryption engine registers. The AES module is clocked at the GLIU frequency, however, the state registers only update on an enable pulse that occurs each n cycles, where n is determined by the DIV value. This register should not be changed during an AES operation.  00: Divide by 1 (use for 100 MHz GLIU or less). 01: Divide by 2 (use for 100 MHz to 200 MHz GLIU). 10: Divide by 3 (use for 200 MHz to 300 MHz GLIU). 11: Divide by 4 (use for 300 MHz to 400 MHz GLIU).

## 6.12.3 Security Block Configuration/Control Registers

## 6.12.3.1 SB Control A (SB\_CTL\_A)

SB Memory Offset 000h  
 Type R/W  
 Reset Value 00000000h

## SB\_CTL\_A Register Map

31	30	29	28	27	26	25	24	23	22	21	20	19	18	17	16	15	14	13	12	11	10	9	8	7	6	5	4	3	2	1	0
RSVD																								RSVD	CBCA	SCA	DCA	WKA	ECA	STA	

## SB\_CTL\_A Register Bit Descriptions

Bit	Name	Description
31:8	RSVD	<b>Reserved.</b>
7:6	RSVD	<b>Reserved.</b> These bits are implemented but reserved for future use. When writing to this register, software should set these bits to 0 and ignore them on read.
5	CBCA	<b>Cipher Block Chaining (CBC) Mode for A Pointer.</b> When set, the AES engine encrypts/decrypts using the Cipher Block Chaining Mode for the A pointer. When reset, the AES engine encrypts/decrypts using the Electronic Codebook (ECB) Mode. No initialization vector is used when in ECB mode.
4	SCA	<b>Source Coherency for A Pointer Set.</b> When set, the source memory fetches using the GLIU interface are flagged as coherent operations. When reset, the operations are non-coherent.
3	DCA	<b>Destination Coherency for A Pointer Set.</b> When set, the destination memory writes using the GLIU interface are flagged as coherent operations. When reset, the operations are non-coherent.
2	WKA	<b>Writable Key for A Pointer Set.</b> When set, the AES engine uses the key from the writable key register (SB Memory Offset 030h-03Ch) for its next operation. When reset, it uses the hidden key value.
1	ECA	<b>Encrypt for A Pointer.</b> When set, the AES operates in encryption mode. When reset, it operates in decryption mode.



**SB\_CTL\_A Register Bit Descriptions (Continued)**

Bit	Name	Description
0	STA	<b>Start for A Pointer.</b> When set, this bit commands the AES to start a new operation based on the current control register setting and the settings in SB Memory Offset 010h and 014h. This bit is reset automatically when the operation completes. Setting this bit also clears the “Complete” flag in the AES Interrupt register (SB Memory Offset 008h[16]) and in SB GLD_MSR_SMI (MSR 58002002h[32]). If an operation using the B pointer set is already underway, the new operation for pointer set A will not start until the previous B operation completes. If both A and B start bits are asserted in the same write operation, the A operation take precedence.

**6.12.3.2 SB Control B (SB\_CTL\_B)**

SB Memory Offset 004h

Type R/W

Reset Value 00000000h

**SB\_CTL\_B Register Map**

31	30	29	28	27	26	25	24	23	22	21	20	19	18	17	16	15	14	13	12	11	10	9	8	7	6	5	4	3	2	1	0
RSVD																							RSVD	CBCB	SCB	DCB	WKB	ECB	STB		

**SB\_CTL\_B Register Bit Descriptions**

Bit	Name	Description
31:8	RSVD	<b>Reserved.</b>
7:6	RSVD	<b>Reserved.</b> These bits are implemented but reserved for future use. When writing to this register, software should set these bits to 0 and ignore them on read.
5	CBCB	<b>Cipher Block Chaining (CBC) Mode for B Pointer.</b> When set, the AES engine encrypts/decrypts using the Cipher Block Chaining Mode for the B pointer. When reset, the AES engine encrypts/decrypts using the Electronic Codebook (ECB) Mode. No initialization vector is used when in ECB mode.
4	SCB	<b>Source Coherency for B Pointer Set.</b> When set, the source memory fetches using the GLIU interface are flagged as coherent operations. When reset, the operations are non-coherent.
3	DCB	<b>Destination Coherency for B Pointer Set.</b> When set, the destination memory writes using the GLIU interface are flagged as coherent operations. When reset, the operations are non-coherent.
2	WKB	<b>Writable Key for B Pointer Set.</b> When set, the AES engine uses the key from the Writable Key register (SB Memory Offset 030h-03Ch) for its next operation. When reset, it uses the hidden key value.
1	ECB	<b>Encrypt for B Pointer.</b> When set, the AES operates in encryption mode. When reset, it operates in decryption mode.
0	STB	<b>Start for B Pointer.</b> When set, this bit commands the AES to start a new operation based on the current control register setting and the settings in SB Memory Offset 020h and 024h. This bit is reset automatically when the operation completes. Setting this bit also clears the “Complete” flag in the AES Interrupt register (SB Memory Offset 008h[17]) and in the SB GLD_MSR_SMI (MSR 58002002h[33]). If an operation using the A pointer set is already underway, the new operation for pointer set B will not start until the previous A operation completes. If both A and B start bits are asserted in the same write operation, the A operation take precedence.

**6.12.3.3 SB AES Interrupt (SB\_AES\_INT)**

SB Memory Offset 008h

Type R/W

Reset Value 00000007h

**SB\_AES\_INT Register Map**

31	30	29	28	27	26	25	24	23	22	21	20	19	18	17	16	15	14	13	12	11	10	9	8	7	6	5	4	3	2	1	0
RSVD													INT_STATUS			RSVD													INT_MASK		

**SB\_AES\_INT Register Bit Descriptions**

Bit	Name	Description
31:19	RSVD	<b>Reserved.</b>
18:16	INT_STATUS	<b>AES Interrupt Status.</b> 0: INT not pending. 1: INT pending.  Writing a 1 to this bit clears the status.  18: EEPROM operation complete. 17: AES context B complete. 16: AES context A complete.
15:3	RSVD	<b>Reserved.</b>
2:0	INT_MASK	<b>AES Interrupt Mask.</b> 0: Enable, unmask the INT. 1: Disabled, mask the INT.  2: When enabled (0), allows EEPROM operation complete INT. 1: When enabled (0), allows AES context B complete INT. 0: When enabled (0), allows AES context A complete INT.

**6.12.3.4 SB Source A (SB\_SOURCE\_A)**

SB Memory Offset 010h

Type R/W

Reset Value 00000000h

**SB\_SOURCE\_A Register Map**

31	30	29	28	27	26	25	24	23	22	21	20	19	18	17	16	15	14	13	12	11	10	9	8	7	6	5	4	3	2	1	0
SOURCE_A																												RSVD			

**SB\_SOURCE\_A Register Bit Descriptions**

Bit	Name	Description
31:4	SOURCE_A	<b>Source A.</b> The Source field is a 32-bit pointer to system memory. It points to the start of data to be encrypted or decrypted. The lower four bits must be written as zero and always read zero. This forces the data fetching to begin on a 16-byte boundary. This register should not be changed during an AES encryption or decryption operation using the A pointer (i.e., while STA is asserted, SB Memory Offset 000h[0] = 1). This register can be modified during an operation using the B pointer set (while STB is asserted, SB Memory Offset 004h[0] = 1).
3:0	RSVD	<b>Reserved.</b> Set to 0.

**6.12.3.5 SB Destination A (SB\_DEST\_A)**

SB Memory Offset 014h

Type R/W

Reset Value 00000000h

**SB\_DEST\_A Register Map**

31	30	29	28	27	26	25	24	23	22	21	20	19	18	17	16	15	14	13	12	11	10	9	8	7	6	5	4	3	2	1	0
Destination A																												RSVD			

**SB\_DEST\_A Register Bit Descriptions**

Bit	Name	Description
31:4	DEST_A	<b>Destination A.</b> The Destination field is a 32-bit pointer to system memory. It points to the start of memory where the results of encryption or decryption operation are to be written. The lower four bits must be written as zero and always read zero. This forces the data writing to begin on a 16-byte boundary. This register should not be changed during an AES encryption or decryption operation using the A pointer set (i.e., while STA is asserted, SB Memory Offset 000h[0] = 1). This register can be modified during an operation using the B pointer set (while STB is asserted, SB Memory Offset 004h[0] = 1).
3:0	RSVD	<b>Reserved.</b> Set to 0.

**6.12.3.6 SB Length A (SB\_LENGTH\_A)**

SB Memory Offset 018h

Type R/W

Reset Value 00000000h

**SB\_LENGTH\_A Register Map**

31	30	29	28	27	26	25	24	23	22	21	20	19	18	17	16	15	14	13	12	11	10	9	8	7	6	5	4	3	2	1	0
LENGTH_A																												RSVD			

**SB\_LENGTH\_A Register Bit Descriptions**

Bit	Name	Description
31:4	LENGTH_A	<b>Length A.</b> The Length field is a 32-bit value that describes the number of bytes to be encrypted or decrypted in the next operation using pointer set A. The lower four bits must be written as zero and always read zero. This forces the data length to be an integer number of 16-byte blocks. This register should not be changed during an AES encryption or decryption operation using the A pointer set (i.e., while STA is asserted, SB Memory Offset 000h[0] = 1). This register can be modified during an operation using the B pointer set (while STB is asserted, SB Memory Offset 004h[0] = 1).
3:0	RSVD	<b>Reserved.</b>

**6.12.3.7 SB Source B (SB\_SOURCE\_B)**

SB Memory Offset 020h

Type R/W

Reset Value 00000000h

**SB\_SOURCE\_B Register Map**

31	30	29	28	27	26	25	24	23	22	21	20	19	18	17	16	15	14	13	12	11	10	9	8	7	6	5	4	3	2	1	0
SOURCE_B																												RSVD			

**SB\_SOURCE\_B Register Bit Descriptions**

Bit	Name	Description
31:4	SOURCE_B	<b>Source B.</b> The Source field is a 32-bit pointer to system memory. It points to the start of data to be encrypted or decrypted. The lower four bits must be written as zero and always read zero. This forces the data fetching to begin on a 16-byte boundary. This register should not be changed during an AES encryption or decryption operation using the A pointer set (i.e., while STA is asserted, SB Memory Offset 000h[0] = 1). This register can be modified during an operation using the B pointer set (while STB is asserted, SB Memory Offset 004h[0] = 1).
3:0	RSVD	<b>Reserved.</b> Set to 0.

**6.12.3.8 SB Destination B (SB\_DEST\_B)**

SB Memory Offset 024h

Type R/W

Reset Value 00000000h

**SB\_DEST\_B Register Map**

31	30	29	28	27	26	25	24	23	22	21	20	19	18	17	16	15	14	13	12	11	10	9	8	7	6	5	4	3	2	1	0
DEST_B																												RSVD			

**SB\_DEST\_B Register Bit Descriptions**

Bit	Name	Description
31:4	DEST_B	<b>Destination B.</b> The Destination field is a 32-bit pointer to system memory. It points to the start of memory where the results of encryption or decryption operation are to be written. The lower four bits must be written as zero and always read zero. This forces the data writing to begin on a 16-byte boundary. This register should not be changed during an AES encryption or decryption operation using the A pointer set (i.e., while STA is asserted, SB Memory Offset 000h[0] = 1). This register can be modified during an operation using the B pointer set (while STB is asserted, SB Memory Offset 004h[0] = 1).
3:0	RSVD	<b>Reserved.</b> Set to 0.

**6.12.3.9 SB Length B (SB\_LENGTH\_B)**

SB Memory Offset 028h

Type R/W

Reset Value 00000000h

**SB\_LENGTH\_B Register Map**

31	30	29	28	27	26	25	24	23	22	21	20	19	18	17	16	15	14	13	12	11	10	9	8	7	6	5	4	3	2	1	0
LENGTH_B																												RSVD			

**SB\_LENGTH\_B Register Bit Descriptions**

Bit	Name	Description
31:4	LENGTH_B	<b>Length B.</b> The Length field is a 32-bit value that describes the number of bytes to be encrypted or decrypted in the next operation using pointer set B. The lower four bits must be written as zero and always read zero. This forces the data length to be an integer number of 16-byte blocks. This register should not be changed during an AES encryption or decryption operation using the A pointer set (i.e., while STA is asserted, SB Memory Offset 000h[0] = 1). This register can be modified during an operation using the B pointer set (while STB is asserted, SB Memory Offset 004h[0] = 1).
3:0	RSVD	<b>Reserved.</b> Set to 0.

**6.12.3.10 SB Writable Key 0 (SB\_WKEY\_0)**

SB Memory Offset 030h

Type WO

Reset Value 00000000h

**SB\_W\_KEY0 Register Map**

31	30	29	28	27	26	25	24	23	22	21	20	19	18	17	16	15	14	13	12	11	10	9	8	7	6	5	4	3	2	1	0
W_EY_0[31:0]																															

**SB\_WKEY\_0 Bit Descriptions**

Bit	Name	Description
31:0	WKEY_0	<b>Writable Key 0.</b> Bits [31:0] of the Writable Key for the Security Block. This register should not be changed during an AES encryption or decryption operation. To prevent one process from reading the key written by another process, this register is not readable.

**6.12.3.11 SB Writable Key 1 (SB\_WKEY\_1)**

SB Memory Offset 034h

Type WO

Reset Value 00000000h

**SB\_WKEY\_1 Register Map**

31	30	29	28	27	26	25	24	23	22	21	20	19	18	17	16	15	14	13	12	11	10	9	8	7	6	5	4	3	2	1	0
WKEY_1[63:32]																															

**SB\_WKEY\_1 Bit Descriptions**

Bit	Name	Description
31:0	WKEY_1	<b>Writable Key 1.</b> Bits [63:32] of the Writable Key for the Security Block. This register should not be changed during an AES encryption or decryption operation. To prevent one process from reading the key written by another process, this register is not readable.

**6.12.3.12 SB Writable Key 2 (SB\_WKEY\_2)**

SB Memory Offset 038h

Type WO

Reset Value 00000000h

**SB\_WKEY\_2 Register Map**

31	30	29	28	27	26	25	24	23	22	21	20	19	18	17	16	15	14	13	12	11	10	9	8	7	6	5	4	3	2	1	0
WKEY_2[95:64]																															

**SB\_WKEY\_2 Bit Descriptions**

Bit	Name	Description
31:0	WKEY_2	<b>Writable Key 2.</b> Bits [95:64] of the Writable Key for the Security Block. This register should not be changed during an AES encryption or decryption operation. To prevent one process from reading the key written by another process, this register is not readable.

**6.12.3.13 SB Writable Key 3 (SB\_WKEY\_3)**

SB Memory Offset 03Ch  
 Type WO  
 Reset Value 00000000h

**SB\_WKEY\_3 Register Map**

31	30	29	28	27	26	25	24	23	22	21	20	19	18	17	16	15	14	13	12	11	10	9	8	7	6	5	4	3	2	1	0
WKEY_3[127:96]																															

**SB\_WKEY\_3 Bit Descriptions**

Bit	Name	Description
31:0	Writable Key 3	<b>Writable Key 3.</b> Bits [127:96] of the Writable Key for the Security Block. This register should not be changed during an AES encryption or decryption operation. To prevent one process from reading the key written by another process, this register is not readable.

**6.12.3.14 SB CBC Initialization Vector 0 (SB\_CBC\_IV\_0)**

SB Memory Offset 040h  
 Type R/W  
 Reset Value 00000000h

**SB\_CBC\_IV\_0 Register Map**

31	30	29	28	27	26	25	24	23	22	21	20	19	18	17	16	15	14	13	12	11	10	9	8	7	6	5	4	3	2	1	0
CBC_IV_0[31:0]																															

**SB\_CBC\_IV\_0 Bit Descriptions**

Bit	Name	Description
31:0	CBC_IV_0 [31:0]	<b>CBC Initialization Vector 0 [31:0].</b> Bits [31:0] of the initialization vector (IV) for the CBC AES mode (Cipher Block Chaining). Change this register only when both A and B channels are IDLE. (A and B start bits, SB Memory Offset 000h and 004h, bit 0 = 0). This register must be programmed with the IV vector prior to starting an AES CBC mode encryption or decryption.

**6.12.3.15 SB CBC Initialization Vector 1 (SB\_CBC\_IV\_1)**

SB Memory Offset 044h  
 Type R/W  
 Reset Value 00000000h

**SB\_CBC\_IV\_1 Register Map**

31	30	29	28	27	26	25	24	23	22	21	20	19	18	17	16	15	14	13	12	11	10	9	8	7	6	5	4	3	2	1	0
CBC_IV_1[63:32]																															

**SB\_CBC\_IV\_1 Bit Descriptions**

Bit	Name	Description
31:0	IV[63:32]	<b>CBC Initialization Vector 1 [63:32]</b> . Bits [63:32] of the IV for the CBC AES mode. Change this register only when both A and B channels are IDLE. (A and B start bits, SB Memory Offset 000h and 004h, bit 0 = 0). This register must be programmed with the IV prior to starting an AES CBC mode encryption or decryption.

**6.12.3.16 SB CBC Initialization Vector 2 (SB\_CBC\_IV\_2)**

SB Memory Offset 048h  
 Type R/W  
 Reset Value 00000000h

**SB\_CBC\_IV\_2 Register Map**

31	30	29	28	27	26	25	24	23	22	21	20	19	18	17	16	15	14	13	12	11	10	9	8	7	6	5	4	3	2	1	0
CBC_IV_2[95:64]																															

**SB\_CBC\_IV\_2 Bit Descriptions**

Bit	Name	Description
31:0	CBC_IV_2 [95:64]	<b>CBC Initialization Vector 2 [95:64]</b> . Bits [95:64] of the IV for the CBC AES mode. Change this register only when both A and B channels are IDLE. (A and B start bits, SB Memory Offset 000h and 004h, bit 0 = 0). This register must be programmed with the IV prior to starting an AES CBC mode encryption or decryption.

**6.12.3.17 SB CBC Initialization Vector 3 (SB\_CBC\_IV\_3)**

SB Memory Offset 04Ch  
 Type R/W  
 Reset Value 00000000h

**SB\_CBC\_IV\_3 Register Map**

31	30	29	28	27	26	25	24	23	22	21	20	19	18	17	16	15	14	13	12	11	10	9	8	7	6	5	4	3	2	1	0
CBC_IV_3[127:96] (rev2.0)																															

**SB\_CBC\_IV\_3 Bit Descriptions**

Bit	Name	Description
31:0	CBC_IV_3 [127:96]	<b>CBC Initialization Vector 3 [127:96]</b> . Bits [127:96] of the IV for the CBC AES Mode. Change this register only when both A and B channels are IDLE. (A and B start bits, SB Memory Offset 000h and 004h, bit 0 = 0). This register must be programmed with the IV prior to starting an AES CBC mode encryption or decryption.



**6.12.3.18 SB Random Number (SB\_RANDOM\_NUM)**

SB Memory Offset 050h

Type RO

Reset Value 00000000h

**SB\_RANDOM\_NUM Register Map**

31	30	29	28	27	26	25	24	23	22	21	20	19	18	17	16	15	14	13	12	11	10	9	8	7	6	5	4	3	2	1	0
RANDOM_NUM																															

**SB Random Number Bit Descriptions**

Bit	Name	Description
31:0	RANDOM_NUM	<b>Random Number.</b> Returns a 32-bit random number. Check the TRNG_VALID bit (SB Memory Offset 054h[0]) before reading this register. If the status bit (TRNG_VALID) is 1, the value in this register is ready for use. A 0 in the status bit indicates that the random number is in the process of being generated.

**6.12.3.19 SB Random Number Status (SB\_RANDOM\_NUM\_STATUS)**

SB Memory Offset 054h

Type RO

Reset Value 00000001h

**SB\_RANDOM\_NUM\_STATUS Register Map**

31	30	29	28	27	26	25	24	23	22	21	20	19	18	17	16	15	14	13	12	11	10	9	8	7	6	5	4	3	2	1	0
RSVD																															TRNG_VALID

**SB\_RANDOM\_NUM\_STATUS Bit Descriptions**

Bit	Name	Description
31:1	RSVD	<b>Reserved.</b> Returns 0.
0	TRNG_VALID	<b>Random Number Valid.</b> When 1, the random number is valid. When 0, the random number is in the process of being generated.

**6.12.3.20 SB EEPROM Command (SB\_EEPROM\_COMM)**

SB Memory Offset 800h

Type R/W

Reset Value 00000000h

**SB\_EEPROM\_COMM Register Map**

31	30	29	28	27	26	25	24	23	22	21	20	19	18	17	16	15	14	13	12	11	10	9	8	7	6	5	4	3	2	1	0
RSVD																								RSVD	HKD	SD	KV	EX	WR	ST	

**SB\_EEPROM\_COMM Bit Descriptions**

Bit	Name	Description
31:8	RSVD	<b>Reserved.</b>
7:6	RSVD	<b>Reserved.</b> These bits are implemented but reserved for future use. When writing to this register, software should set these bits to 0 and ignore them on read.
5	HKD	<b>Hidden Key Disable.</b> Reset to 0. When set, this bit disables the hidden key by forcing all of the bits to zero. This bit can be written to a 1 by software, but once set, it can only be cleared by reset. Setting this bit also forces the Key Valid bit (bit 3) to 0.
4	SD	<b>Soft Lock.</b> Reset to 0. When set, this bit locks the same debug functions locked by the DBL bit (SB Memory Offset 80Ch[10:8]), and is displayed in the Access Control register. This bit can be written to a 1 by software, but once set, it can only be cleared by reset.
3	KV	<b>Key Valid.</b> Reset to 0. After reset, this bit is set automatically by the state machine to indicate that the automatic load of the hidden key into the AES key register has completed and the key is now ready for use. No AES operations using the hidden key register should be initiated before this bit is set. This bit is cleared by reset or by asserting the Hidden Key Disable bit (bit 5).
2	EX	<b>Exception.</b> The current access operation did not complete successfully. Note that this bit may also be set after a reset if the initial read of the EEPROM control bytes or hidden key did not complete successfully. This bit should only be set on a fatal hardware access error. Write 1 to clear. If the exception occurs on the initial EEPROM read after reset, it is assumed that no EEPROM is preset and the EEPROM interface is disabled. When the interface is disabled, this bit is not clearable.
1	WR	<b>Write.</b> When set, the EEPROM interface initiates a write operation to the EEPROM when the START bit (bit 0) is set. When reset, the EEPROM interface initiates a read operation when the START bit is set.
0	ST	<b>START.</b> When set, this bit commands the EEPROM interface to start a new operation based on the current Control register setting and the settings in the Address and Data registers. This bit is reset automatically when the operation completes. Setting this bit also clears the EEPROM Complete flag in the AES Interrupt register (SB Memory Offset 008h[18]) and in the SMI MSR register (MSR 58002002h[34]).

**6.12.3.21 SB EEPROM Address (SB\_EEPROM\_ADDR)**

SB Memory Offset 804h

Type R/W

Reset Value 000000FFh

**SB\_EEPROM\_ADDR Register Map**

31	30	29	28	27	26	25	24	23	22	21	20	19	18	17	16	15	14	13	12	11	10	9	8	7	6	5	4	3	2	1	0
RSVD											RSVD			EE_ADDR																	

**SB\_EEPROM\_ADDR Bit Descriptions**

Bit	Name	Description
31:11	RSVD	<b>Reserved.</b>
10:8	RSVD	<b>Reserved.</b> These bits are reserved for future expansion of the EEPROM size and must be written to 0.
7:0	EE_ADDR	<b>EEPROM Address.</b> This is the 8-bit address for accessing one of the 256 bytes within the EEPROM array.

**6.12.3.22 SB EEPROM Data (SB\_EEPROM\_DATA)**

SB Memory Offset 808h

Type R/W

Reset Value 00000000h

This register contains the Data bits for writing to or reading from the EEPROM.

**SB\_EEPROM\_DATA Register Map**

31	30	29	28	27	26	25	24	23	22	21	20	19	18	17	16	15	14	13	12	11	10	9	8	7	6	5	4	3	2	1	0
RSVD																EE_DATA															

**SB\_EEPROM\_DATA Bit Descriptions**

Bit	Name	Description
31:8	RSVD	<b>Reserved.</b>
7:0	EE_DATA	<b>EEPROM Data.</b> This register holds the 8-bit data value to be written the EEPROM array or the data most recently read from the array. Note that when reading a hidden location, this register will return the previous read or write data with no indication of an error. Writes to locked locations are ignored with no indication of an error.

### 6.12.3.23 SB EEPROM Security State (SB\_EEPROM\_SEC\_STATE)

SB Memory Offset 80Ch  
 Type RO  
 Reset Value 00000000h

This read only register contains the current state of the access control bits for controlling reads and writes from/to the EEPROM. It is reloaded from the EEPROM array after every reset. The initial state of the EEPROM is all ones. Therefore the unlocked state of the control bits must be one. The user locks the part by programming zeroes into the protect bits of the Access Control bytes. Each lock control is a 3-bit field. The user normally programs all three bits to a zero. The multi-bit fields are used to prevent a single bit disturb of the EEPROM array from unlocking the part.

#### SB\_EEPROM\_SEC\_STATE Register Map

31	30	29	28	27	26	25	24	23	22	21	20	19	18	17	16	15	14	13	12	11	10	9	8	7	6	5	4	3	2	1	0
RSVD																EEPROM byte 1						EEPROM byte 0									
RSVD																WPE			DBL			RSVD		WPU		WPL					

#### SB\_EEPROM\_SEC\_STATE Bit Descriptions

Bit	Name	Description
31:14	RSVD	<b>Reserved.</b>
13:11	WPE	<b>Write Protect Extended.</b> Reserved for future use. This register holds the 3-bit value of the access control bits used to block write access to any address above the 2 Kbit range (byte address greater than 255). This is included for possible future support of larger EEPROM memories. With the currently specified 2 Kbit memory, these bits have no effect. If any of these bits are reset, write operations are blocked to addresses above 255. These bits correspond to the state of bits [5:3] of byte 1 of the EEPROM array as read after the last reset. To change these bits, the user must program the Access Control byte 1 (address 1 of the EEPROM), and the part must be reset.
10:8	DBL	<b>Debug Lock.</b> This register holds the 3-bit value of the access control bits used to disable certain debug features of the AMD Geode LX processor. If any of these bits are reset, debug operations are blocked. These bits correspond to the state of bits [2:0] of byte 1 of the EEPROM array as read after the last reset. To change these bits, the User must program the Access Control byte 1 (address 1 of the EEPROM), and the part must be reset. Although reset to the locked state (000), these bits will revert to the unlocked state (111), if no EEPROM is detected after reset. This unlocking will occur approximately 17 ms after the release from reset with no EEPROM present.
7:6	RSVD	<b>Reserved.</b>
5:3	WPU	<b>Write Protect Upper.</b> This register holds the 3-bit value of the access control bits used to block write access to the upper half of the EEPROM array, (address 120 through 255). If any of these bits are reset, write operations are blocked. These bits correspond to the state of bits [5:3] of byte 0 of the EEPROM array as read after the last reset. To change these bits, the user must program the Access Control byte 0 (address 0 of the EEPROM), and the part must be reset.
2:0	WPL	<b>Write Protect Lower.</b> This register holds the 3-bit value of the access control bits used to block write access to the lower half of the EEPROM array, (address 0 through 127). (Note, these addresses include these access control bits as well as the hidden key bits.) If any of these bits are reset, write operations are blocked forever. These bits correspond to the state of bits [2:0] of byte 0 of the EEPROM array as read after the last reset. To change these bits, the user must program the Access Control byte 0 (address 0 of the EEPROM), and the part must be reset.

### 6.13 GeodeLink™ Control Processor

The GeodeLink Control Processor (GLCP) functionality covers these areas (see Figure 6-55):

- Scan chain control
- JTAG interface to boundary scan, BIST, GLIU1, and debug logic
- Power (clock) control
- Reset logic
- PLL control
- Internal logic analyzer/debugger
- 1KB FIFO/SRAM
- Compliant with GLIU System Architecture Specification v1.07
- Supports AMD Geode™ CS5536 companion device interface
- Supports physical pins for SUSPA# and IRQ13
- Supports muxed pin for SUSP#

#### 6.13.1 TAP Controller

The TAP controller is IEEE 1149.1 compliant. TMS, TDI, TCLK, and TDO are directly supported (TRST is available as a bootstrap pin during reset, but is always inactive if the system reset is inactive). The Instruction register (IR) is 25 bits wide. The meanings of the various instructions are shown in Table 6-81 on page 534 along with the length of the Data register that can be accessed once the instruction is entered. All Data registers shift in and out data, LSB first. The Instruction and all Data registers are shift registers, so if more bits are shifted in than the register can hold, only the last bits shifted in (the MSBs) are used.

The TAP controller has specific pre-assigned meanings to the bits in the 25-bit IR. The meanings are summarized in Table 6-82 on page 534. Note that the bits only affect the chip once the “Update-IR” JTAG state occurs in the JTAG controller. Shifting through these bits does not change the state of internal signals (for example TEST\_MODE). For details on JTAG controller states, refer to the IEEE Standard 1149.1-1990.

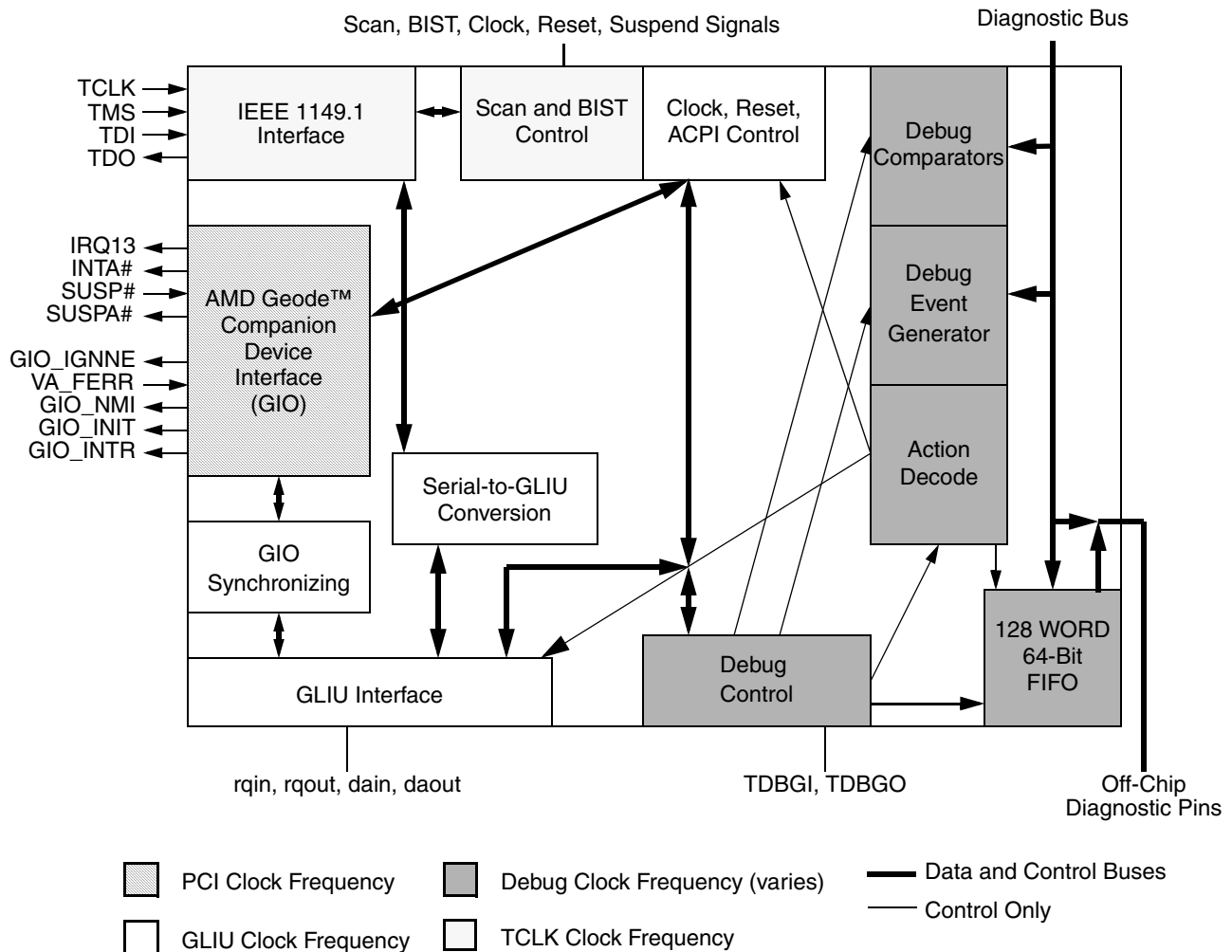


Figure 6-55. GLCP Block Diagram

**Table 6-81. TAP Control Instructions (25-Bit IR)**

Instruction	DR Length	IR Name	Description
123FFFAh	8	BYPASS_MODES	This register is read/write.
127FFFAh	8	REVID	Should be 10h for initial AMD Geode™ LX processor (upper nibble is major rev, lower nibble is minor) changes for each metal spin
1FFFE0h	441	MULTISCAN	Parallel scan (muxes scan outputs onto many chip pins)
1FFFFDFh	1	TRISTATE	Put chip into TRI-STATE and comparison mode
1FFFFDh	29	BISTDR	Parallel RAM BIST - internal data register (for chip test)
1FFFFEh	32	IDCODE	ID Code = 0D5A1003h
1FFFFFFh	1	BYPASS	Bypass; IEEE 1149.1 spec requires all 1s to be bypass

**Table 6-82. TAP Instruction Bits**

Bit	Name	Description
24	TAPSCAN#	Also USER[6] in the design. This is a user bit added by AMD; low indicates that an internal scan chain is accessed by the TAP.
23:18	USER[5:0]	User bits used to identify an internal scan chain or, if bit 24 is high, to access a special internal DR, as shown in Table 6-81.
17:16	bistEnable[4:3]	Bits 4 and 3 of the BIST enable for individual BIST chain access.
15:13	clkRatio[2:0]#	Not used in the AMD Geode™ LX processor (bits should always be high); clock ratio controls for LogicBist.
12	freezeMode	Not used in the AMD Geode LX processor (should always be high); another clock control signal.
11:10	setupMode[1:0]#	Not used in the AMD Geode LX processor (should always be high); these are special BIST controller bits.
9:7	bistEnable[2:0]	BIST[2:0] of BIST enable. Works in conjunction with bits [17:16].
6	testMode#	Active low TEST_MODE for entire chip. Puts internal logic into scan test mode.
5	forceDis#	Active low bit TRI-STATEs all output pins.
4	selectJtagOut#	Active low bit that allows boundary scan cells to control pads.
3	selectJtagIn#	Active low bit that allows boundary scan cells to drive data into core logic of chip.
2:0	OP[2:0]	Opcode that selects how the JTAG chains are wired together.

## EXTEST JTAG Instruction

The EXTEST instruction accesses the boundary scan chain around the chip and controls the pin logic such that the boundary scan data controls the data and enable signals for the pins. IEEE 1149.1 requires that an all-zero instruction access the boundary scan chain; the controller actually catches the all-zero condition during the “Update-IR” state and loads 1FFFFE8h into the internal instruction register. As seen by Table 6-82, this select OP = 000 (access boundary scan chain) and selectJtagOut# is set active so that the boundary cells control the pads.

## DELAY\_CONTROLS

This chain controls the delay timing for the inputs and outputs. This register can be overridden with an MSR write to GLCP\_DELAY\_CONTROLS (GLCP MSR 4C00000Fh) if bit 63 of the MSR is set high. Bits [62:0] of this register have the same meaning as in the MSR description for GLCP\_DELAY\_CONTROLS (see Section 6.14.2.8 on page 549).

## REVID

This 8-bit JTAG register can be reprogrammed with any metal layer change to identify silicon changes. This register has the same value as the GLCP\_REV\_ID bits (MSR 4C002000h[7:0]).

## MULTISCAN

During manufacturing test, multiple scan chains are available on the signal pins. Table 6-81 on page 534 identifies the specific scan behaviors of various pins when in this mode. The Data register associated with this TAP instruction is the boundary scan chain and the instruction bits configure the pads such that the boundary scan ring is providing data into the core and the captured data on the boundary scan chain is the data coming from the core.

## TRI-STATE

This instruction TRI-STATes all of the signals. The Data register accessed is the Bypass register.

## BYPASS

According to IEEE 1149.1, shifting all 1s into the IR must connect the 1-bit Bypass register. The register has no function except as a storage flip-flop.

## 6.13.2 Reset Logic

One of the major functions of the GLCP is to control the resetting of the AMD Geode LX processor. There are two methods to reset the processor: either by a hard reset using the input signal RESET#, or by a soft reset by writing to an internal MSR in the GLCP.

RESET# is used for power-on reset. During power-on reset, all internal blocks are reset until the release of the RESET# signal.

Soft reset is activated by writing to GLCP\_SYS\_RSTPLL (MSR 4C000014h). Soft reset resets all the internal blocks

to their initial status except the TAP controller. TAP reset is achieved by holding IRQ13 low during power-on reset.

## 6.13.3 Clock Control

The clock control function controls the generation of the AMD Geode LX processor internal clocks. For this purpose, there are two MSRs: GLCP\_SYS\_RSTPLL and GLCP\_DOTPLL (MSR 4C000014h and 4C000015h).

As shown in Figure 6-56 on page 536, the internal clocks are generated by SYSPLL and DOTPLL. In normal operation mode MSR 4C000014h[12, 11] = 0 and MSR 4C000015h[15] = 0. The SYSPLL output clock drives the internal clocks of the CPU Core, the GeodeLink modules, and SDRAM. The output of DOTPLL drives the DOTCLK, that in turn, drives the Video Processor and Display Controller modules.

In Bypass mode, when MSR 4C000014h[12] = 1, the DOTREF input clock drives the clocks of the GLIU and SDRAM, and when MSR 4C000014h[11] = 1 the DOTREF input clock drives the clocks of the CPU Core. Also, when GLCP\_DOTPLL[15] = 1, the DOTREF input drives the DOTCLK.

### 6.13.3.1 Power Management

The GLCP controls the chip-wide power management by controlling when to activate and deactivate the PLL clocks of the AMD Geode LX processor.

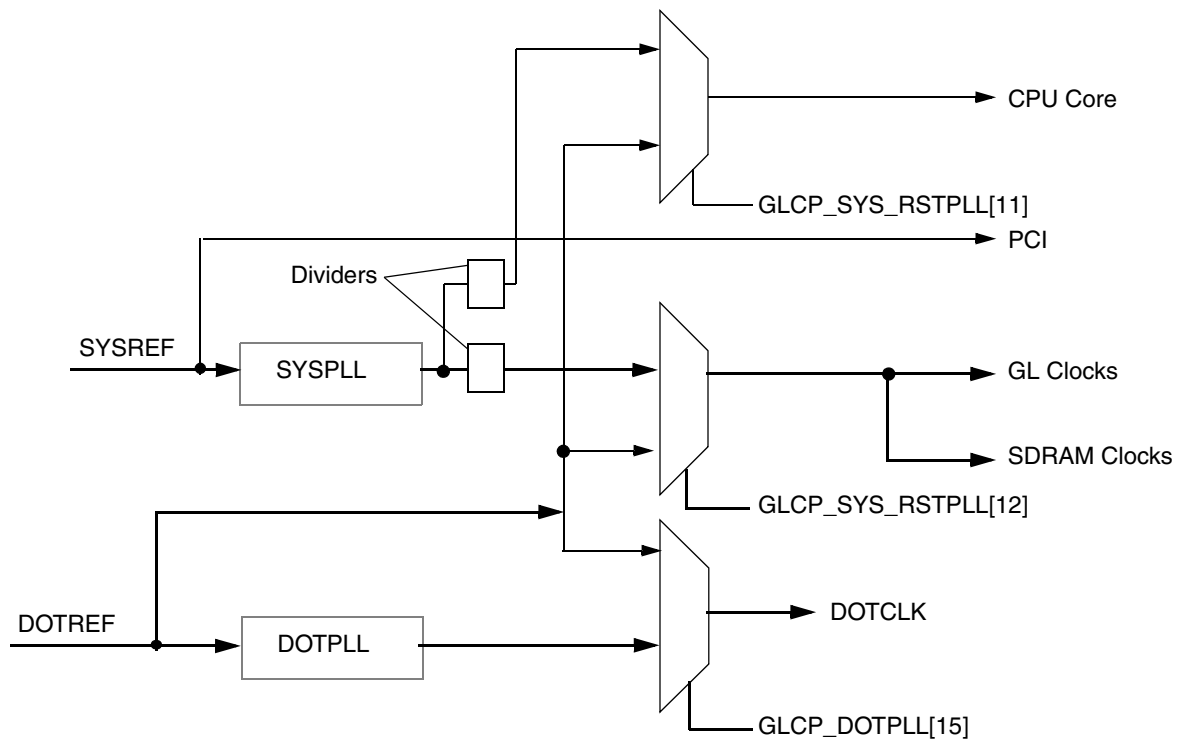
Selection of module-level hardware clock gating is done by programming the GLD\_MSR\_PM (MSR 4C002004h) of each module. When hardware clock gating is activated, each module enters into power save mode when it is not busy, and leaves power save mode if a new GeodeLink request or external event is received.

Each module has a power management module called clock control.

### GLIU1 Power Management Support

The GLCP MSRs directly involved in power management are:

- GLCP Clock Disable Delay Value (GLCP\_CLK\_DIS\_DELAY)
- GLCP Global Power Management Controls (GLCP\_GLB\_PM)
- GLCP Clock Mask for Sleep Request (GLCP\_PMCLKDISABLE)
- GLCP Clock Active Mask for Suspend Acknowledge (GLCP\_CLK4ACK)
- GLCP Control (GLCP\_CNT)
- GLCP Level 2 (GLCP\_LVL2)
- GLCP Throttle or C2 Start Delay (GLCP\_TH\_SD)
- GLCP Scale Factor (GLCP\_TH\_SF)
- GLCP Processor Throttle Off Delay (GLCP\_TH\_OD)



**Figure 6-56. Processor Clock Generation**

### 6.13.4 Companion Device Interface

The AMD Geode companion device interface for I/O connections (GIO) provides the system interface between the AMD Geode CS5536 companion device and the AMD Geode LX processor. The GIO supports companion device modes for current and future companion device needs. The major blocks (shown in Figure 6-57 on page 537) of the GIO are:

- GIO\_GLIU
- GIO\_SYNC
- GIO\_PCI

#### Features

- CS5536 companion device support:
  - Supports CPU Interface Serial (CIS) that mux'es signals: INPUT\_DISABLE, OUTPUT\_DISABLE and Legacy (LGCY) signals: A20M, INIT, SUSP, NMI, INTR, SMI.
  - System interface signals clocked on raw PCI input clock.
- No master capabilities.

#### 6.13.4.1 GIO\_GLIU

The GIO\_GLIU interface module is responsible for all the GLIU slave functionality. The GIO\_GLIU slave implements a large MSR space consisting of the required standard GLIU device MSRs and the MSR controls for the I/O companion modes and the Legacy signals. The GIO\_GLIU must properly decode all possible GLIU transaction types including the unexpected addresses, request types and sizes, and must return the proper number of responses. In addition, it provides error logic to detect unexpected addresses and types and implements the processor floating point exception handling logic.

#### 6.13.4.2 GIO\_SYNC

The GIO synchronization module, GIO\_SYNC, handles synchronization of all signals that cross from the GLIU to PCI domain or PCI to GLIU domain.

#### 6.13.4.3 GIO\_PCI

The GIO\_PCI module drives the values of the system interface signals. Table 6-83 on page 537 shows the source of each output signal in each of the AMD Geode companion device modes.



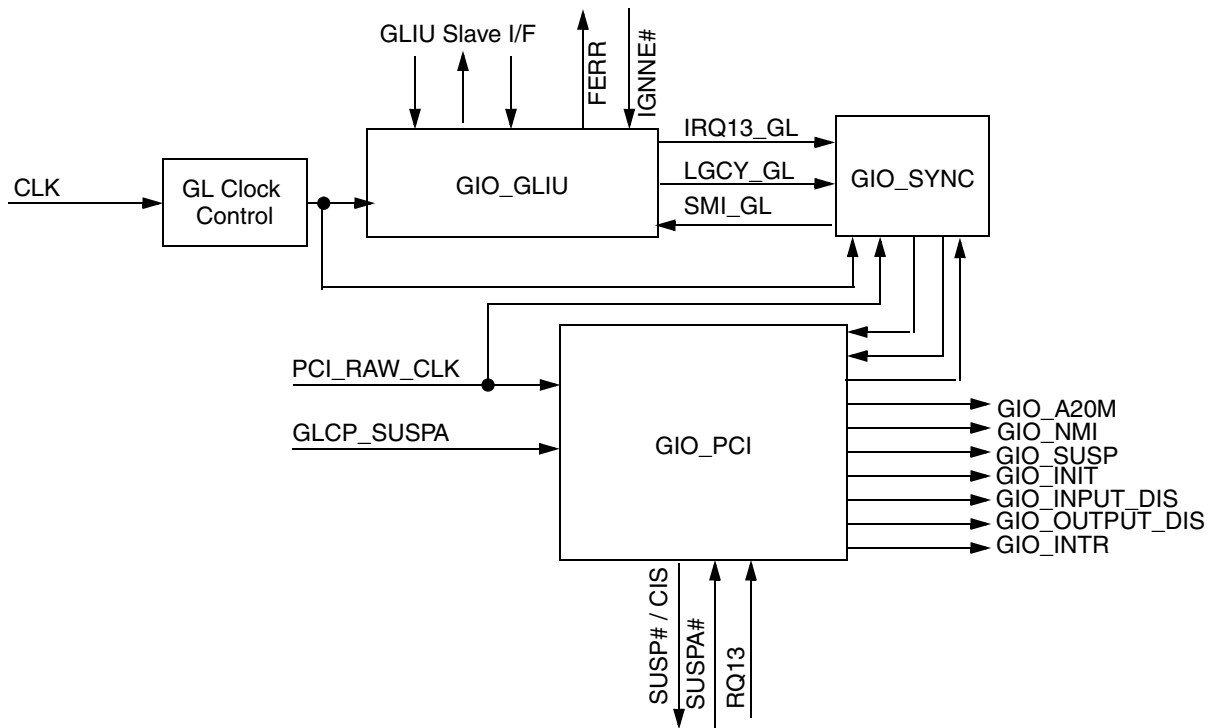


Figure 6-57. GIO Interface Block Diagram

Table 6-83. GIO\_PCI Outputs

GIO Output	Mode A	Mode B
GIO_SUSP	SUSP# pin in serial mode	SUSP# pin in serial mode
GIO_SUSPA	SUSPA# pin	SUSPA# pin
GIO_IRQ13	IRQ13 pin	IRQ13 pin

### GIO\_PCI Serial Protocol

The GIO can override the functionality of its SUSP# pin to create a serial bus called CPU Interface Serial (CIS). The reset mode for this pin is the SUSP# function. To properly operate as the CIS interface, the CISM bit in MSR 51000010h[4:3] in the companion device must be programmed for Mode C. Notice that all the input signals are active low. They are all inverted inside the GIO and converted to active high signals. The protocol is shown in Table 6-84. The SUSP# pin must always be parked as inactive or 1.

Serial packets are expected whenever the companion device signals transitions. Back to back serial packets can occur once the entire serial packet has completed. The AMD Geode LX processor decoded signals are guaranteed to transition only after the entire completion of the packet, although they may transition during the transmission of the packet.

### SUSP#/CIS Pin Initialization

The SUSP# function must NOT be active until the initialization code can set the CISM bits in the companion device to set the correct companion device mode.

### GIO\_SMI Synchronization

If the companion device generates a synchronous SMI in response to a specific CPU initiated instruction (I/O), the SMI# signal is transmitted to the processor before the completion of the PCI cycle. Therefore, the companion device must not complete read or write cycles until it has transmitted the SMI. The design guarantees that if the PCI cycle completes on the PCICLK after the SMI transmission, the SMI will reach the processor before the I/O completion response. Therefore, the processor can handle the SMI before completing the instruction.

### GIO\_A20M

GIO\_A20M is emulated with an SMI. The processor receives an SMI from the companion device on I/Os that modify the state of A20M. The SMI handler must then write to MSR\_A20M (MSR 4C000031h) in the GIO to trigger a real A20M signal back to the processor. When the instruction completes, A20M is asserted.

### GIO\_NMI

The GIO\_NMI signal is the real NMI from the companion device.

### GIO\_INPUT\_DIS, GIO\_OUTPUT\_DIS

GIO\_INPUT\_DIS and GIO\_OUTPUT\_DIS are part of the GLIU power management. See the *AMD Geode™ CS5536 Companion Device Data Book* (publication ID 33238) for details.

### GIO\_INIT

GIO\_INIT is triggered via MSR 4C000033h in the GLCP for all companion device modes. INIT is used to reset the CPU. It is NOT a CPU soft reset.

**Table 6-84. CIS Signaling Protocol**

Phase	Bit Definition (GIO CIS Mode C)
0 (START)	0
1 (START)	0
2	RSVD
3	RSVD
4	SUSP#
5	NMI#
6	INPUT_DIS#
7	OUTPUT_DIS#
8	SMI#
9	INTR#
10	1
11	1
12	1
13	1
14	1
15	1
16	1
17	1
18 (END)	1
19 (END)	1

## 6.14 GeodeLink™ Control Processor Register Descriptions

All GeodeLink Control Processor registers are Model Specific Registers (MSRs) and are accessed via the RDMSR and WRMSR instructions.

The registers associated with the GLCP are the Standard GeodeLink™ Device (GLD) MSRs and GLCP Specific MSRs. Table 6-85 and Table 6-86 are register summary

tables that include reset values and page references where the bit descriptions are provided.

**Note:** The MSR address is derived from the perspective of the CPU Core. See Section 4.1 "MSR Set" on page 45 for more details on MSR addressing.

**Table 6-85. Standard GeodeLink™ Device MSRs Summary**

MSR Address	Type	Register Name	Reset Value	Reference
4C002000h	RO	GLD Capabilities MSR (GLD_MSR_CAP)	00000000_00002400h	Page 541
4C002001h	R/W	GLD Master Configuration MSR (GLD_MSR_CONFIG)	00000000_00000000h	Page 541
4C002002h	R/W	GLD SMI MSR (GLD_MSR_SMI)	00000000_0000001Fh	Page 542
4C002003h	R/W	GLD Error MSR (GLD_MSR_ERROR)	00000000_00000000h	Page 543
4C002004h	R/W	GLD Power Management MSR (GLD_MSR_PM)	00000000_00000015h	Page 544
4C002005h	R/W	GLD Diagnostic MSR (GLD_MSR_DIAG)	00000000_00000000h	Page 544

**Table 6-86. GLCP Specific MSRs Summary**

MSR Address	Type	Register Name	Reset Value	Reference
<b>GLCP Control MSRs</b>				
4C000008h	R/W	GLCP Clock Disable Delay Value (GLCP_CLK_DIS_DELAY)	00000000_00000000h	Page 545
4C000009h	R/W	GLCP Clock Mask for Sleep Request (GLCP_PMCLKDISABLE)	00000000_00000000h	Page 545
4C00000Ah	RO	Chip Fabrication Information (GLCP_FAB)	00000000_00000001h	Page 547
4C00000Bh	R/W	GLCP Global Power Management Controls (GLCP_GLB_PM)	00000000_00000000h	Page 547
4C00000Ch	R/W	GLCP Debug Output from Chip (GLCP_DBGOUT)	00000000_00000000h	Page 548
4C00000Dh	R/W	GLCP Processor Status (GLCP_PROCSTAT)	Bootstrap Dependant	Page 548
4C00000Eh	R/W	GLCP DOWSER (GLCP_DOWSER)	00000000_00000000h	Page 549
4C00000Fh	R/W	GLCP I/O Delay Controls (GLCP_DELAY_CONTROLS)	00000000_00000000h	Page 549
4C000010h	R/W	GLCP Clock Control (GLCP_CLKOFF)	00000000_00000000h	Page 551
4C000011h	RO	GLCP Clock Active (GLCP_CLKACTIVE)	Input Determined	Page 552
4C000012h	R/W	GLCP Clock Mask for Debug Clock Stop Action (GLCP_CLKDISABLE)	00000000_00000000h	Page 553
4C000013h	R/W	GLCP Clock Active Mask for Suspend Acknowledge (GLCP_CLK4ACK)	00000000_00000000h	Page 553
4C000014h	R/W	GLCP System Reset and PLL Control (GLCP_SYS_RSTPLL)	Bootstrap specific	Page 554

Table 6-86. GLCP Specific MSRs Summary (Continued)

MSR Address	Type	Register Name	Reset Value	Reference
4C000015h	R/W	GLCP Dot Clock PLL Control (GLCP_DOTPLL)	000000D7_02000000h	Page 557
4C000016h	R/W	GLCP Debug Clock Control (GLCP_DBGCLKCTL)	00000000_00000002h	Page 559
4C000017h	RO	Chip Revision ID (GLCP_CHIP_REVID)	00000000_000000xxh	Page 559
<b>GLCP I/O Address MSRs</b>				
4C000018h	R/W - I/O Offset 00h	GLCP Control (GLCP_CNT)	00000000_000000Fh	Page 560
4C000019h	R/W - I/O Offset 04h	GLCP Level 2 (GLCP_LVL2)	00000000_00000000h	Page 560
4C00001Ah	--	Reserved	--	--
4C00001Bh	--	Reserved	--	--
4C00001Ch	R/W - I/O Offset 10h	GLCP Throttle or C2 Start Delay (GLCP_TH_SD)	00000000_00000000h	Page 561
4C00001Dh	R/W - I/O Offset 14h	GLCP Scale Factor (GLCP_TH_SF)	00000000_00000000h	Page 561
4C00001Eh	R/W - I/O Offset 18h	GLCP Processor Throttle Off Delay (GLCP_TH_OD)	00000000_00000000h	Page 562
4C00001Eh	R/W - I/O Offset 18h	GLCP Processor Throttle Off Delay (GLCP_TH_OD)	00000000_00000000h	Page 562
4C00001Fh	--	Reserved	--	--
<b>GLCP Debug Interface MSRs</b>				
4C000023h	R/W	GLCP DAC (GLCP_DAC)	00000000_00000000h	Page 563
<b>GLCP IGNNE I/Os</b>				
F0h, F1h	W	GLCP IGNNE I/Os	NA	Page 562
<b>GLCP I/O Companion Interface MSRs</b>				
4C000031h	R/W	CPU A20M Signal (MSR_A20M)	00000000_00000000h	Page 564
4C000033h	R/W	CPU INIT Signal (MSR_INIT)	00000000_00000000h	Page 564
4C000036h	RO	GLIU Device Interrupt Status (MSR_INTAX)	00000000_00000000h	Page 565

## 6.14.1 Standard GeodeLink™ Device MSRs

### 6.14.1.1 GLD Capabilities MSR (GLD\_MSR\_CAP)

MSR Address 4C002000h  
 Type RO  
 Reset Value 00000000\_00002400h

**GLD\_MSR\_CAP Register Map**

63	62	61	60	59	58	57	56	55	54	53	52	51	50	49	48	47	46	45	44	43	42	41	40	39	38	37	36	35	34	33	32
RSVD																															
31	30	29	28	27	26	25	24	23	22	21	20	19	18	17	16	15	14	13	12	11	10	9	8	7	6	5	4	3	2	1	0
RSVD								DEV_ID																REV_ID							

**GLD\_MSR\_CAP Bit Descriptions**

Bit	Name	Description
63:24	RSVD	<b>Reserved.</b> Reads as 0.
23:8	DEV_ID	<b>Device ID.</b> Identifies device (0024h).
7:0	REV_ID	<b>Revision ID.</b> Identifies device revision. See <i>AMD Geode™ LX Processors Specification Update</i> document for value.

### 6.14.1.2 GLD Master Configuration MSR (GLD\_MSR\_CONFIG)

MSR Address 4C002001h  
 Type R/W  
 Reset Value 00000000\_00000000h

**GLD\_MSR\_CONFIG Register Map**

63	62	61	60	59	58	57	56	55	54	53	52	51	50	49	48	47	46	45	44	43	42	41	40	39	38	37	36	35	34	33	32
RSVD																															
31	30	29	28	27	26	25	24	23	22	21	20	19	18	17	16	15	14	13	12	11	10	9	8	7	6	5	4	3	2	1	0
RSVD																												PID			

**GLD\_MSR\_CONFIG Bit Descriptions**

Bit	Name	Description
63:3	RSVD	<b>Reserved.</b> Write as read.
2:0	PID	<b>Assigned Priority Domain.</b> Unused by the GLCP.

**6.14.1.3 GLD SMI MSR (GLD\_MSR\_SMI)**

MSR Address 4C002002h  
 Type R/W  
 Reset Value 00000000\_0000001Fh

**GLD\_MSR\_SMI Register Map**

63	62	61	60	59	58	57	56	55	54	53	52	51	50	49	48	47	46	45	44	43	42	41	40	39	38	37	36	35	34	33	32
RSVD																															
31	30	29	28	27	26	25	24	23	22	21	20	19	18	17	16	15	14	13	12	11	10	9	8	7	6	5	4	3	2	1	0
RSVD											SMI_EXT	SMI_PML2	SMI_PMCNT	SMI_DBG	SMI_ERR	RSVD											SMI_EXT_MASK	SMI_PML2_MASK	SMI_PMCNT_MASK	SMI_DBG_MASK	SMI_ERR_MASK

**GLD\_MSR\_SMI Bit Descriptions**

Bit	Name	Description
63:21	RSVD	<b>Reserved.</b>
20	SMI_EXT	<b>SMI from I/O Companion.</b> ASMI generated when most recent serial packet had SMI bit set. This bit ALWAYS represents the state of the SMI bit in the last serial packet received. It cannot be written. To clear external SMI sources, proper external controls must be sent (i.e., via the PCI bus).
19	SMI_PML2	<b>SMI Power Management GLCP_LVL2.</b> SSMI generated when GLCP_LVL2 (MSR 4C000019h) I/O register was read. Write 1 to clear, 0 has no effect.
18	SMI_PMCNT	<b>SMI Power Management GLCP_CNT Mask.</b> SSMI generated when GLCP_CNT (MSR 4C000018h) I/O register was written. Write 1 to clear, 0 has no effect.
17	SMI_DBG	<b>SMI Debug.</b> ASMI generated due to debug event or PROCSTAT access. Write 1 to clear, 0 has no effect.
16	SMI_ERR	<b>SMI Error.</b> ASMI generated due to error signal. Write 1 to clear, 0 has no effect.
15:5	RSVD	<b>Reserved.</b>
4	SMI_EXT_MASK	<b>SMI from I/O Companion Mask.</b> If clear, enables serial packets from external device to generate an ASMI.
3	SMI_PML2_MASK	<b>SMI Power Management GLCP_LVL2 Mask.</b> If clear, enables power management logic to generate an SSMI when GLCP_LVL2 I/O register (MSR 4C000019h) is read.
2	SMI_PMCNT_MASK	<b>SMI Power Management GLCP_CNT Mask.</b> If clear, enables power management logic to generate an SSMI when GLCP_CNT (MSR 4C000018h) I/O register is written.
1	SMI_DBG_MASK	<b>SMI Debug Mask.</b> If clear, enables debug logic to generate an ASMI.
0	SMI_ERR_MASK	<b>SMI Error Mask.</b> If clear, then any GLIU device error signal (including GLCP) causes an ASMI.

**6.14.1.4 GLD Error MSR (GLD\_MSR\_ERROR)**

MSR Address 4C002003h  
 Type R/W  
 Reset Value 00000000\_00000000h

**GLD\_MSR\_ERROR Register Map**

63	62	61	60	59	58	57	56	55	54	53	52	51	50	49	48	47	46	45	44	43	42	41	40	39	38	37	36	35	34	33	32
RSVD																												ERR_SYSPLL	ERR_DOTPLL	ERR_SIZE	ERR_TYPE
31	30	29	28	27	26	25	24	23	22	21	20	19	18	17	16	15	14	13	12	11	10	9	8	7	6	5	4	3	2	1	0
RSVD																												ERR_SYSPLL_MASK	ERR_DOTPLL_MASK	ERR_SIZE_MASK	ERR_TYPE_MASK

**GLD\_MSR\_ERROR Bit Descriptions**

Bit	Name	Description
63:36	RSVD	<b>Reserved.</b>
35	ERR_SYSPLL	<b>Error System PLL.</b> System PLL lock signal was active when POR was inactive. Writing 1 clears error; 0 leaves unchanged.
34	ERR_DOTPLL	<b>Error Dot Clock PLL.</b> Dot clock PLL lock signal was active when POR was inactive. Writing 1 clears error; 0 leaves unchanged.
33	ERR_SIZE	<b>Error Size.</b> The GLIU interface detected a read or write of more than 1 data packet (size = 16 bytes or 32 bytes). If a response packet is expected, the exception bit will be set, in all cases the asynchronous error signal will be set. Writing 1 clears error; 0 leaves unchanged.
32	ERR_TYPE	<b>Error Type.</b> An unexpected type was sent to the GLCP GLIU interface (start request with BEX type, snoop, peek_write, debug_req, or NULL type). If a response packet is expected, the exception bit will be set, in all cases the asynchronous error signal will be set. Writing a 1 clears the error, writing a 0 leaves unchanged.
31:4	RSVD	<b>Reserved.</b>
3	ERR_SYSPLL_MASK	<b>Error System PLL Mask.</b> When set to 1, disables error signaling based on the state of the ERR_SYSPLL flag (bit 35).
2	ERR_DOTPLL_MASK	<b>Error Dot Clock PLL Mask.</b> When set to 1, disables error signaling based on the state of the ERR_DOTPLL flag (bit 34).
1	ERR_SIZE_MASK	<b>Error Size Mask.</b> When set to 1, disables error signaling based on the state of the ERR_SIZE flag (bit 33).
0	ERR_TYPE_MASK	<b>Error Type Mask.</b> When set to 1, disables error signaling based on the state of the ERR_TYPE flag (bit 32).

**6.14.1.5 GLD Power Management MSR (GLD\_MSR\_PM)**

MSR Address 4C002004h  
 Type R/W  
 Reset Value 00000000\_00000015h

The debug logic powers up selecting GLIU1 for its clock. Debug clock select is in GLCP\_DBGCLKCTL (MSR 4C000016h[2:0]).

**GLD\_MSR\_PM Register Map**

63	62	61	60	59	58	57	56	55	54	53	52	51	50	49	48	47	46	45	44	43	42	41	40	39	38	37	36	35	34	33	32
RSVD																															
31	30	29	28	27	26	25	24	23	22	21	20	19	18	17	16	15	14	13	12	11	10	9	8	7	6	5	4	3	2	1	0
RSVD																											PM_PCI		PM_DBG		PM_GLIU

**GLD\_MSR\_PM Bit Descriptions**

Bit	Name	Description
63:32	RSVD	<b>Reserved.</b> Write as read.
31:6	RSVD	<b>Reserved.</b> Write as 0.
5:4	PM_PCI	<b>GLCP PCI Clock Power Mode.</b> 00: Clock always on. 01: Hardware clock gating (GIO interface will wake instantly when SUSP goes low). 1x: Reserved.
3:2	PM_DBG	<b>GLCP Debug Clock Power Mode.</b> 00: Clock always on. 01: Hardware clock gating if debug inactive (if GLCP_DBGCLKCTL = 0). 1x: Reserved.
1:0	PM_GLIU	<b>GLCP GLIU Clock Power Mode.</b> 00: Clock always on. 01: Hardware clock gating if GLCP inactive. 1x: Reserved.

**6.14.1.6 GLD Diagnostic MSR (GLD\_MSR\_DIAG)**

MSR Address 4C002005h  
 Type R/W  
 Reset Value 00000000\_00000000h

This register is reserved for internal use by AMD and should not be written to.



### 6.14.2 GLCP Specific MSRs - GLCP Control MSRs

#### 6.14.2.1 GLCP Clock Disable Delay Value (GLCP\_CLK\_DIS\_DELAY)

MSR Address 4C000008h  
 Type R/W  
 Reset Value 00000000\_00000000h

**GLCP\_CLK\_DIS\_DELAY Register Map**

63	62	61	60	59	58	57	56	55	54	53	52	51	50	49	48	47	46	45	44	43	42	41	40	39	38	37	36	35	34	33	32
RSVD																															
31	30	29	28	27	26	25	24	23	22	21	20	19	18	17	16	15	14	13	12	11	10	9	8	7	6	5	4	3	2	1	0
RSVD								CLK_DELAY																							

**GLCP\_CLK\_DIS\_DELAY Bit Descriptions**

Bit	Name	Description
63:24	RSVD	<b>Reserved.</b> Write as read.
23:0	CLK_DELAY	<b>Clock Disable Delay.</b> If enabled in GLCP_GLB_PM (CLK_DLY_EN bit, MSR 4C00000Bh[4] = 1), indicates the period to wait from SLEEP_REQ before gating off clocks specified in GLCP_PMCLKDISABLE (MSR 4C000009h). If this delay is enabled, it overrides or disables the function of GLCP_CLK4ACK (MSR 4C000013h). If the CLK_DLY_EN bit is not set, but this register is non-zero, then this register serves as a timeout for the CLK4ACK behavior.

#### 6.14.2.2 GLCP Clock Mask for Sleep Request (GLCP\_PMCLKDISABLE)

MSR Address 4C000009h  
 Type R/W  
 Reset Value 00000000\_00000000h

**GLCP\_PMCLKDISABLE Register Map**

63	62	61	60	59	58	57	56	55	54	53	52	51	50	49	48	47	46	45	44	43	42	41	40	39	38	37	36	35	34	33	32
RSVD																														VIPVIP	VIPGLIU
31	30	29	28	27	26	25	24	23	22	21	20	19	18	17	16	15	14	13	12	11	10	9	8	7	6	5	4	3	2	1	0
AES	AESGLIU	AESEE	GLCPDBG	GLCPGLIU	GLCPPCI	VPVOP	VPDOT_2	VPDOT_1	VPDOT_0	VPGLIU_1	VPGLIU_0	PCIPCIF	PCIPCI	PCIGLIU	GLIU1_1	GLIU1_0	DCGLIU_1	DCGLIU_0	RSVD	DCDOT_0	GLIU0_1	GLIU0_0	GP	GLMC	DRAM	BC_GLIU	BC_VA	MSS	IPIPE	FPFAST	FPUSLOW

**GLCP\_PMCLKDISABLE Bit Descriptions**

Bit	Name	Description
63:34	RSVD	<b>Reserved.</b>
33	VIPVIP	<b>VIP VIPCLK Off.</b> When set, disables VIP VIPCLK.
32	VIPGLIU	<b>VIP GLIU Clock Off.</b> When set, disables VIP GLIU clock.
31	AES	<b>AES Core Functional Clock Off.</b> When set, disables AES encryption/decryption clock.
30	AESGLIU	<b>AES GLIU Clock Off.</b> When set, disables AES GLIU interface clock.
29	AESEE	<b>AES EEPROM Clock Off.</b> When set, disables AES EEPROM clock.

## GLCP\_PMCLKDISABLE Bit Descriptions (Continued)

Bit	Name	Description
28	GLCPDBG	<b>GLCP Debug Clock Off.</b> When set, disables GLCP DBG logic clock.
27	GLCPGLIU	<b>GLCP GLIU Clock Off.</b> When set, disables GLCP GLIU clock.
26	GLCPPCI	<b>GLCP GIO PCI Clock Off.</b> When set, disables GLCP's GIO PCI clock.
25	VPVOP	<b>VP VOP Clock Off.</b> When set, disables VOP logic clock.
24	VPDOT_2	<b>VP Dot Clock 2 Off.</b> When set, disables VP Dot Clock 2 (vp_vid).
23	VPDOT_1	<b>VP DOT Clock 1 Off.</b> When set, disables VP Dot Clock 1 (lcd_pix).
22	VPDOT_0	<b>VP DOT Clock 0 Off.</b> When set, disables VP Dot Clock 0 (vp_pix).
21	VPGLIU_1	<b>VP GLIU Clock 1 Off.</b> When set, disables VP GLIU Clock 1 (lcd).
20	VPGLIU_0	<b>VP GLIU Clock 0 Off.</b> When set, disables VP GLIU Clock 0 (vp).
19	PCICIPF	<b>Fast PCI Clock Off.</b> When set, disables fast PCI clock inside GLPCI block.
18	PCIPCI	<b>PCI Clock Off.</b> When set, disables normal PCI clock inside GLPCI block.
17	PCIGLIU	<b>GLPCI Clock Off.</b> When set, disables clock entering GLPCI block.
16	GLIU1_1	<b>GLIU1 Clock Off.</b> When set, disables main clock to secondary GLIU.
15	GLIU1_0	<b>GLIU1 Timer Logic Clock Off.</b> When set, disables clock to timer logic of secondary GLIU.
14	DCGLIU_1	<b>DC GLIU clock 1 Off.</b> When set, disables DC GLIU Clock 1 (vga).
13	DCGLIU_0	<b>DC GLIU clock 0 Off.</b> When set, disables DC GLIU Clock 0 (DC).
12	RSVD	<b>Reserved.</b> Unused bit, reads what was written, value written has no effect.
11	DCDOT_0	<b>DC Dot Clock Off.</b> When set, disables DC Dot Clock 0 (DC).
10	GLIU0_1	<b>GLIU0 Clock Off.</b> When set, disables main clock to primary GLIU.
9	GLIU0_0	<b>GLIU0 Timer Logic Clock Off.</b> When set, disables clock to timer logic of primary GLIU.
8	GP	<b>GP Clock Off.</b> When set, disables GP clock (GLIU).
7	GLMC	<b>GLMC Clock Off.</b> When set, disables GLIU clock to GLMC.
6	DRAM	<b>DRAM Clocks Off.</b> When set, disables external DRAM clocks (and, hence, feedback clocks).
5	BC_GLIU	<b>Bus Controller Clock Off.</b> When set, disables clock to CPU bus controller block.
4	BC_VA	<b>CPU to Bus Controller Clock Off.</b> When set, disables CPU clock to bus controller block.
3	MSS	<b>CPU to MSS Clock Off.</b> When set, disables CPU clock to memory subsystem block.
2	IPIPE	<b>CPU to IPIPE Clock Off.</b> When set, disable CPU clock to IPIPE block.
1	FPUFAST	<b>FPU Fast Clock Off.</b> When set, disables the fast FPU clock.
0	FPUSLOW	<b>FPU Clock Off.</b> When set, disables the slow CPU clock to FPU.

**6.14.2.3 Chip Fabrication Information (GLCP\_FAB)**

MSR Address 4C00000Ah  
 Type RO  
 Reset Value 00000000\_00000001h

This read only register is used to track various fab, process, and product family parameters. It is meant for AMD internal use only. Reads return reset value.

**6.14.2.4 GLCP Global Power Management Controls (GLCP\_GLB\_PM)**

MSR Address 4C00000Bh  
 Type R/W  
 Reset Value 00000000\_00000000h

**GLCP\_GLB\_PM Register Map**

63	62	61	60	59	58	57	56	55	54	53	52	51	50	49	48	47	46	45	44	43	42	41	40	39	38	37	36	35	34	33	32	
RSVD																																
31	30	29	28	27	26	25	24	23	22	21	20	19	18	17	16	15	14	13	12	11	10	9	8	7	6	5	4	3	2	1	0	
RSVD														DOTPLL_EN	SYSPLL_EN	RSVD				OUT_VP	OUT_GIO	OUT_GLMC	OUT_PCI	OUT_OTHER	RSVD			CLK_DLY_EN	CLK_DIS_EN	RSVD	RSVD	THT_EN

**GLCP\_GLB\_PM Bit Descriptions**

Bit	Name	Description
63:18	RSVD	<b>Reserved.</b>
17	DOTPLL_EN	<b>DOTPLL Enable.</b> Enables turning off the Dot clock PLL during sleep when high.
16	SYSPLL_EN	<b>SYSPLL Enable.</b> Enables turning off the system PLLs during sleep when high.
15:13	RSVD	<b>Reserved.</b>
12	OUT_VP	<b>VP Outputs.</b> When set, enables VP outputs to TRI_STATE during a sleep sequence.
11	OUT_GIO	<b>GIO Outputs.</b> When set, enables AMD Geode™ I/O companion (GIO) to TRI_STATE device outputs during a sleep sequence.
10	OUT_GLMC	<b>GLMC Outputs.</b> When set, enables GLMC to TRI_STATE outputs during a sleep sequence.
9	OUT_PCI	<b>GLPCI Outputs.</b> When set, enables GLPCI to TRI_STATE outputs during a sleep sequence.
8	OUT_OTHER	<b>Other Outputs.</b> When set, enables TDBG0 and SUSPA# to TRI_STATE during a sleep sequence.
7:5	RSVD	<b>Reserved.</b>
4	CLK_DLY_EN	<b>Clock Delay Enable.</b> Enables gating off clock enables from a delay rather than GLCP_CLK4ACK (MSR 4C000013h) when high.
3	CLK_DIS_EN	<b>Clock Display Enable.</b> Enables the assertion of internal signal, mb_clk_dis_req, during a sleep sequence when high.
2:1	RSVD	<b>Reserved.</b>
0	THT_EN	<b>Throttle Enable.</b> Enables processor throttling functions. If this bit is low, all the functions related to throttling are disabled (GLCP_TH_OD, GLCP_CNT, etc.).

**6.14.2.5 GLCP Debug Output from Chip (GLCP\_DBGOUT)**

MSR Address 4C00000Ch  
 Type R/W  
 Reset Value 00000000 00000000h

This register is reserved for internal use by AMD and should not be written to.

**6.14.2.6 GLCP Processor Status (GLCP\_PROCSTAT)**

MSR Address 4C00000Dh  
 Type R/W  
 Reset Value Bootstrap Dependant

Note that the names of these bits have the read status data before the "\_" and the write behavior after it.

**GLCP\_PROCSTAT Register Map**

63	62	61	60	59	58	57	56	55	54	53	52	51	50	49	48	47	46	45	44	43	42	41	40	39	38	37	36	35	34	33	32
RSVD																															
31	30	29	28	27	26	25	24	23	22	21	20	19	18	17	16	15	14	13	12	11	10	9	8	7	6	5	4	3	2	1	0
RSVD																								RESET_NONE	STOPCLK_NONE	GLACT_UNSTALL	GLCPSTALL_DMI	STALL_SMI	SUSP_STOPCLK	DMI_STALL	

**GLCP\_PROCSTAT Bit Descriptions**

Bit	Name	Description
63:7	RSVD	<b>Reserved.</b> Writing these bits has no effect.
6	RESET_NONE	<b>Reset Status.</b> When read, this bit is high if a hard or soft reset to the AMD Geode™ LX processor has occurred since this register was last read. Writing this bit has no effect.
5	STOPCLK_NONE	<b>Stop Clock Status.</b> When read, this bit is high if a GLCP stop clock action has occurred since this register was last read. Writing this bit has no effect.
4	GLACT_UNSTALL	<b>GLIU1 Debug Action Status.</b> When read, this bit is high if the GLCP has triggered a GLIU1 debug action since this register was last read. Writing this bit high uninstalls the processor.
3	GLCPSTALL_DMI	<b>GLCP Stall Status.</b> When read, this bit is high if the GLCP is stalling the CPU. Writing this bit high causes a GLCP DMI to the processor.
2	STALL_SMI	<b>CPU Stall Status.</b> When read, this bit is high if the CPU is stalled for any reason. Writing this bit high causes a GLCP SMI to the processor. Bit 1 of GLD_MSR_SMI (MSR 4C000002h) gets set by this SMI and an SMI is triggered, assuming appropriate SMI enable settings.
1	SUSP_STOPCLK	<b>CPU Suspended Stop Clock Status.</b> When read, this bit is high if the CPU has suspended execution for any reason since this register was last read. Writing this bit high causes the GLCP to stop all clocks identified in GLCP_CLKDISABLE (MSR 4C000012h).
0	DMI_STALL	<b>CPU DMI Stall Status.</b> When read, this bit is high if the CPU is in DMI mode. Writing this bit high causes the GLCP to "DEBUG_STALL" the processor.



## GLCP\_DELAY\_CONTROLS Bit Definition (Continued)

Bit	Name	Description
59	SDCLK_SET	SDCLK Setup. 0: Full SDCLK setup. 1: Half SDCLK setup for control signals.
58:56	DDR_RLE	DDR read latch enable position.
55	SDCLK_DIS	SDCLK disable [1,3,5]. 0: All SDCLK output. 1: SDCLK[4,2,0] output only.
54:52	TLA1_OA	TLA hint pin output adjust.
51:50	D_TLA1	Output delay for TLA1.
49:48	D_TLA0	Output delay for TLA0.
47:46	D_DQ_E	Output delay for DQ, DQM - even byte lanes.
45:44	D_DQ_O	Output delay for DQ, DQM - odd byte lanes.
43:42	RSVD	Reserved.
41:40	D_SDCLK	Output delay for SDCLK.
39:38	D_CMD_O	Output delay for CKE, CS, RAS, CAS, WE - odd bits.
37:36	D_CMS_E	Output delay for CKE, CS, RAS, CAS, WE - even bits.
35:34	D_MA_O	Output delay for BA and MA - odd bits.
33:32	D_MA_E	Output delay for BA and MA - even bits.
31:30	D_PCI_O	Output delay for pci_ad, IRQ13, SUSPA#, INTA# - odd bits.
29:28	D_PCI_E	Output delay for pci_ad, CBE#, PAR, STOP#, FRAME#, IRDY#, TRDY#, DEVSEL#, REQ#, GNT# - even bits.
27:26	D_DOTCLK	Output delay for DOTCLK.
25:24	D_DRBG_O	Output delay for DRGB[31:0] - odd bits.
23:22	D_DRBG_E	Output delay for DRGB[31:0], HSYNC, VSYNC, DISPEN, VDDEN, LDE_MOD - even bits.
21:20	D_PCI_IN	Input delay for AD[31:0], CBE#, PAR, STOP#, FRAME#, IRDY#, TRDY#, DEVSEL#, REQ#, GNT#, CIS.
19:18	D_TDBGI	Input delay for TDBGI.
17:16	D_VIP	Input delay for VID[15:0], VIP_HSYNC, VIP_VSYNC.
15:14	D_VIPCLK	Input delay for VIPCLK.
13	H_SDCLK	Half SDCLK hold select (for cmd addr). 1: Half SDCLK setup for MA and BA signals. 0: Full SDCLK setup.
12:11	PLL_FD_DEL	PLL Feedback Delay. 00: No feedback delay. 11: Max feedback delay. (01: ~350 ps, 10: ~700 ps, 11: ~1100 ps).
10:6	RSVD	<b>Reserved.</b>
5	DLL_OV	DLL Override (to DLL).
4:0	DLL_OVS/RSDA	DLL Override Setting or Read Strobe Delay Adjust. When DLL Override is 1 this is the DQS overide delay. When DLL Override is 0 this is the offset adjust value.

**6.14.2.9 GLCP Clock Control (GLCP\_CLKOFF)**

MSR Address 4C000010h  
 Type R/W  
 Reset Value 00000000\_00000000h

This register has bits that, when set, force clocks off using GeodeLink™ Clock Control (GLCC) logic in the system. This is for debugging only, and should not be used for power management.

**GLCP\_CLKOFF Register Map**

63	62	61	60	59	58	57	56	55	54	53	52	51	50	49	48	47	46	45	44	43	42	41	40	39	38	37	36	35	34	33	32			
RSVD																																	VIPVIP	VIPGLIU
31	30	29	28	27	26	25	24	23	22	21	20	19	18	17	16	15	14	13	12	11	10	9	8	7	6	5	4	3	2	1	0			
AES	AESGLIU	AESEE	GLCPDBG	GLCPGLIU	GLCPPCI	VPVOP	VPDOT_2	VPDOT_1	VPDOT_0	VPGLIU_1	VPGLIU_0	PCIPCIF	PCIPCI	PCIGLIU	GLIU1_1	GLIU1_0	DCGLIU_1	DCGLIU_0	RSVD	DCDOT_0	GLIU0_1	GLIU0_0	GP	GLMC	DRAM	BC_GLIUS	BC_VA	MSS	IPIPE	FPUFAST	FPUSLOW			

**GLCP\_CLKOFF Bit Descriptions**

Bit	Name	Description
63:34	RSVD	<b>Reserved.</b>
33	VIPVIP	<b>VIP VIPCLK Off.</b> When set, disables VIP VIPCLK.
32	VIPGLIU	<b>VIP GLIU Clock Off.</b> When set, disables VIP GLIU clock.
31	AES	<b>AES Core Functional Clock Off.</b> When set, disables AES encryption/decryption clock.
30	AESGLIU	<b>AES GLIU Clock Off.</b> When set, disables AES GLIU interface clock.
29	AESEE	<b>AES EEPROM Clock Off.</b> When set, disables AES EEPROM clock.
28	GLCPDBG	<b>GLCP Debug Clock Off.</b> When set, disables GLCP DBG logic clock.
27	GLCPGLIU	<b>GLCP GLIU Clock Off.</b> When set, disables GLCP GLIU clock.
26	GLCPPCI	<b>GLCP GIO PCI Clock Off.</b> When set, disables GLCP's GIO PCI clock.
25	VPVOP	<b>VP VOP Clock Off.</b> When set, disables VOP logic clock.
24	VPDOT_2	<b>VP DOT Clock 2 Off.</b> When set, disables VP Dot Clock 2 (vp_vid).
23	VPDOT_1	<b>VP Dot Clock 1 Off.</b> When set, disables VP Dot Clock 1 (lcd_pix).
22	VPDOT_0	<b>VP Dot Clock 0 Off.</b> When set, disables VP Dot Clock 0 (vp_pix).
21	VPGLIU_1	<b>VP GLIU Clock 1 Off.</b> When set, disables VP GLIU Clock 1 (lcd).
20	VPGLIU_0	<b>VP GLIU Clock 0 Off.</b> When set, disables VP GLIU Clock 0 (vp).
19	PCIPCIF	<b>Fast PCI Clock Off.</b> When set, disables fast PCI clock inside GLPCI block.
18	PCIPCI	<b>PCI Clock Off.</b> When set, disables normal PCI clock inside GLPCI block.
17	PCIGLIU	<b>GLPCI Clock Off.</b> When set, disables clock entering GLPCI block.
16	GLIU1_1	<b>GLIU1 Clock Off.</b> When set, disables main clock to secondary GLIU.
15	GLIU1_0	<b>GLIU1 Timer Logic Clock Off.</b> When set, disables clock to timer logic of secondary GLIU.
14	DCGLIU_1	<b>DC GLIU Clock 1 Off.</b> When set, disables DC GLIU Clock 1 (VGA).
13	DCGLIU_0	<b>DC GLIU Clock 0 Off.</b> When set, disables DC GLIU Clock 0 (DC).
12	RSVD	<b>Reserved.</b> Unused bit, reads what was written, value written has no effect.

**GLCP\_CLKOFF Bit Descriptions (Continued)**

Bit	Name	Description
11	DCDOT_0	<b>DC Dot Clock Off.</b> When set, disables DC Dot Clock 0 (DC).
10	GLIU0_1	<b>GLIU0Clock Off.</b> When set, disables main clock to primary GLIU.
9	GLIU0_0	<b>GLIU0 Timer Logic Clock Off.</b> When set, disables clock to timer logic of primary GLIU.
8	GP	<b>GP Clock Off.</b> When set, disables GP clock (GLIU).
7	GLMC	<b>GLMC Clock Off.</b> When set, disables GLIU clock to memory controller.
6	DRAM	<b>DRAM Clocks Off.</b> When set, disables external DRAM clocks (and, hence, feedback clocks).
5	BC_GLIU	<b>Bus Controller Clock Off.</b> When set, disables clock to CPU bus controller block.
4	BC_VA	<b>CPU to Bus Controller Clock Off.</b> When set, disables CPU clock to bus controller block.
3	MSS	<b>CPU to MSS Clock Off.</b> When set, disables CPU clock to MSS block.
2	IPIPE	<b>CPU to IPIPE Clock Off.</b> When set, disable CPU clock to IPIPE block.
1	FPUFAST	<b>FPU Fast Clock Off.</b> When set, disables the fast FPU clock.
0	FPUSLOW	<b>FPU Clock Off.</b> When set, disables the slow CPU clock to FPU.

**6.14.2.10 GLCP Clock Active (GLCP\_CLKACTIVE)**

MSR Address 4C000011h  
 Type RO  
 Reset Value Input Determined

**GLCP\_CLKACTIVE Register Map**

63	62	61	60	59	58	57	56	55	54	53	52	51	50	49	48	47	46	45	44	43	42	41	40	39	38	37	36	35	34	33	32	
RSVD																																
AES	AESGLIU	AESEE	GLCPDBG	GLCPGLIU	GLCPPCI	VPVOP	VPDOT_2	VPDOT_1	VPDOT_0	VPGLIU_1	VPGLIU_0	PCIPCF	PCIPCI	PCIGLIU	GLIU1_1	GLIU1_0	DCGLIU_1	DCGLIU_0	RSVD	DCDOT_0	GLIU0_1	GLIU0_0	GP	GLMC	DRAM	BC_GLIU	BC_VA	MSS	IPIPE	FPUFAST	FPUSLOW	

See "GLCP\_CLKOFF Bit Descriptions" on page 551 for bit descriptions.



**6.14.2.11 GLCP Clock Mask for Debug Clock Stop Action (GLCP\_CLKDISABLE)**

MSR Address 4C000012h  
 Type R/W  
 Reset Value 00000000\_00000000h

**GLCP\_CLKDISABLE Register Map**

63	62	61	60	59	58	57	56	55	54	53	52	51	50	49	48	47	46	45	44	43	42	41	40	39	38	37	36	35	34	33	32			
RSVD																																	VIPVIP	VIPGLIU
31	30	29	28	27	26	25	24	23	22	21	20	19	18	17	16	15	14	13	12	11	10	9	8	7	6	5	4	3	2	1	0			
AES	AESGLIU	AESEE	GLCPDBG	GLCPGLIU	GLCPPCI	VPVOP	VPDOT_2	VPDOT_1	VPDOT_0	VPGLIU_1	VPGLIU_0	PCIPCIF	PCIPCI	PCIGLIU	GLIU1_1	GLIU1_0	DCGLIU_1	DCGLIU_0	RSVD	DCDOT_0	GLIU0_1	GLIU0_0	GP	GLMC	DRAM	BC_GLIU	BC_VA	MSS	IPIPE	FPUFAST	FPUSLOW			

See "GLCP\_CLKOFF Bit Descriptions" on page 551 for bit descriptions.

**6.14.2.12 GLCP Clock Active Mask for Suspend Acknowledge (GLCP\_CLK4ACK)**

MSR Address 4C000013h  
 Type R/W  
 Reset Value 00000000\_00000000h

**GLCP\_CLK4ACK Register Map**

63	62	61	60	59	58	57	56	55	54	53	52	51	50	49	48	47	46	45	44	43	42	41	40	39	38	37	36	35	34	33	32			
RSVD																																	VIPVIP	VIPGLIU
31	30	29	28	27	26	25	24	23	22	21	20	19	18	17	16	15	14	13	12	11	10	9	8	7	6	5	4	3	2	1	0			
AES	AESGLIU	AESEE	GLCPDBG	GLCPGLIU	GLCPPCI	VPVOP	VPDOT_2	VPDOT_1	VPDOT_0	VPGLIU_1	VPGLIU_0	PCIPCIF	PCIPCI	PCIGLIU	GLIU1_1	GLIU1_0	DCGLIU_1	DCGLIU_0	RSVD	DCDOT_0	GLIU0_1	GLIU0_0	GP	GLMC	DRAM	BC_GLIU	BC_VA	MSS	IPIPE	FPUFAST	FPUSLOW			

See "GLCP\_CLKOFF Bit Descriptions" on page 551 for bit descriptions.

**6.14.2.13 GLCP System Reset and PLL Control (GLCP\_SYS\_RSTPLL)**

MSR Address 4C000014h  
 Type R/W  
 Reset Value Bootstrap specific

This register is initialized during POR, but otherwise is not itself reset by any “soft-reset” features. Note that writing this register always has immediate effect, so read-modify-writes must be done to avoid corrupting the PLL timing settings. When using this register functionally to change PLL frequencies, the CHIP\_RESET bit (bit 0) should be set. Writing this register with the CHIP\_RESET bit set will never send a write-response over the GLIU (this allows halting bus traffic before the reset occurs).

**GLCP\_SYS\_RSTPLL Register Map**

63	62	61	60	59	58	57	56	55	54	53	52	51	50	49	48	47	46	45	44	43	42	41	40	39	38	37	36	35	34	33	32
RSVD														GLIUMULT				MBDIV	COREMULT				COREDIV								
31	30	29	28	27	26	25	24	23	22	21	20	19	18	17	16	15	14	13	12	11	10	9	8	7	6	5	4	3	2	1	0
SWFLAGS						GLIULOCK	CORELOCK	HOLD_COUNT								RSVD	GLIUPD	COREPD	GLIUBYPASS	COREBYPASS	LPFEN	VA_SEMI_SYNC_MODE	PCI_SEMI_SYNC_MODE	BOOTSTRAPS					CHIP_RESET		

**GLCP\_SYS\_RSTPLL Bit Descriptions**

Bit	Name	Description
63:44	RSVD	<b>Reserved.</b>
43:39	GLIUMULT	<b>GLIU Multiplier (Bootstrap Dependent, see Table 6-87).</b> 00000: Multiply by 1,.... 11111: Multiply by 32.
38	GLIUDIV	<b>GLIU Divide.</b> When set, predivide the GLIU PLL input frequency by 2. 0: Do not predivide input. (Default) 1: Divide by 2.
37:33	COREMULT	<b>CPU Core Multiplier (bootstrap dependent, see Table 6-87 on page 556).</b> 00000: Multiply by 1,.... 11111: Multiply by 32.
32	COREDIV	<b>CPU Core Divide.</b> When set, predivide the GLIU PLL input frequency by 2. 0: Do not predivide input. (Default) 1: Divide by 2.
31:26	SWFLAGS	<b>Flags.</b> Flags that are reset only by the POR# signal, not the CHIP_RESET (bit 0). They are reset to 0 and can be used as flags in the boot code that survive CHIP_RESET.
25	GLIULOCK (RO)	<b>Lock (Read Only).</b> Lock signal from the system PLL. The worst-case lock time for a AMD Geode™ LX processor PLL is 100 µs.
24	CORELOCK (RO)	<b>Lock (Read Only).</b> Lock signal from the system PLL. The worst-case lock time for a AMD Geode LX processor PLL is 100 µs.

## GLCP\_SYS\_RSTPLL Bit Descriptions (Continued)

Bit	Name	Description
23:16	HOLD_COUNT	<b>Hold Count.</b> The number of PLL reference clock cycles (divided by 16) that the PLL is powered down for, and also the number before releasing CHIP_RESET. 0: Wait 0 cycles. (Default) 1: Wait 16 clock cycles, etc.
15	RSVD	<b>Reserved.</b> Always write 0.
14	GLIUPD	<b>GLIU Power Down.</b> This signal controls the power down mode of the GLIU PLL. It is active high. This bit is always cleared by a CHIP_RESET (bit 0).
13	COREPD	<b>Core Power Down.</b> This signal controls the power down mode of the CPU core PLL. It is active high. This bit is always cleared by a CHIP_RESET (bit 0).
12	GLIUBYPASS	<b>GLIU Bypass.</b> This signal controls the Bypass mode of the GLIU clocking. If this bit is high, the DOTPLL is configured for bypass and the DOTREF input clock directly drives the GLIU clock spines. (For SYSREF bypass through the GLIU PLL, the CLKSEL JTAG register must be used).
11	COREBYPASS	<b>Core Bypass.</b> This signal controls the Bypass mode of the Core clock. If this bit is high, the DOTPLL is configured for bypass and the DOTREFF input clock directly drives the Core clock. (For SYSREF bypass through the Core PLL, the CLKSEL JTAG register must be used).
10	LPFEN	<b>Loop Filter Enable.</b> This bit is tied to both the GLIU and Core PLL loop filter enables. This PLL control enables the use of an external resistor. It should be clear for normal operation.
9	VA_SEMI_SYNC_MODE	<b>CPU Sync Mode.</b> This bit controls whether the CPU uses a FIFO for interfacing with the GLIU. If the bit is high, the CPU will not use the FIFO. It behaves as if the CPU and GLIU domains are synchronous. This bit can be set high as long as the CPU and GLIU frequencies are multiples of each other. The bit is always reset low.
8	PCI_SEMI_SYNC_MODE	<b>PCI Sync Mode.</b> This bit controls whether the PCI uses the falling edges of mb_func_clk and pci_func_clk for interfacing with GLIU or not. If the bit is high, PCI does not use falling clock edges. It behaves as if the PCI and GLIU domains are synchronous. This bit can be set high as long as the PCI and GLIU frequencies are multiples of each other. The bit always resets low.
7:1	BOOTSTRAPS (RO)	<b>Bootstraps (Read Only).</b> These bits are copies of the state of bootstraps when power-on reset (PCI reset) is released. Bit 7: PW1 pad - active high when the PCI clock is 66 MHz, low for 33 MHz. Bit 6: IRQ13 pad - active high for stall-on-reset debug feature, otherwise low. Bit 5: PW0 pad - part of CPU/GLIU frequency selects. Bit 4: SUSPA# pad - part of CPU/GLIU frequency selects. Bit 3: GNT2# pad - part of CPU/GLIU frequency selects. Bit 2: GNT1# pad - part of CPU/GLIU frequency selects. Bit 1: GNT0# pad - part of CPU/GLIU frequency selects.
0	CHIP_RESET	<b>Chip Reset.</b> When written to a 1, the chip enters reset and does not come out until the HOLD_COUNT (bits [23:16]) is reached. This register and the JTAG logic are not reset by CHIP_RESET, but otherwise the entire chip is reset. (Default = 0)

The PW1 pin (66 MHz PCI) is wired directly to the COREDIV and GLDIV signals during reset. The IRQ13 pin (stall after reset) has no effect on the PLL controls but is still stored in the BOOTSTRAP bits (MSR 4C000018h[7:1]). Table 6-87 shows examples of reset values when PW1 and/or IRQ13 are high during reset. The hard reset state of this register always leaves the PLL in bypass mode. The BIOS must clear the bypass bits in order to achieve the desired frequency.

**Table 6-87. Bootstrap Bit Settings and Reset State of GLCP\_SYS\_RSTPLL (PW1 and IRQ13 = 0)**

{PW1,IRQ13,PW0,SUSPA#, GNT#[2:0]} same as GLCP_SYS_RSTPLL[7:1]	CPU Core Speed (MHz)	CPU Core MULT	GLIU Speed (MHz)	GLIU MULT	GLCP_SYS_RSTPLL Reset Value
0000000	Bypass	11	Bypass	7	00000396_00001800h
0000001	166	4	166	4	00000208_03001802h
0000010	200	5	200	5	0000028A_03001804h
0000011	266	7	200	5	0000028E_03001806h
0000100	266	7	266	7	0000038E_03001808h
0000101	333	9	200	5	00000292_0300180Ah
0000110	333	9	266	7	00000392_0300180Ch
0000111	333	9	333	9	00000492_0300180Eh
0001000	366	10	200	5	00000294_03001810h
0001001	366	10	266	7	00000394_03001812h
0001010	366	10	333	9	00000494_03001814h
0001011	400	11	200	5	00000296_03001816h
0001100	400	11	266	7	00000396_03001818h
0001101	400	11	333	9	00000496_0300181Ah
0001110	400	11	400	11	00000596_0300181Ch
0001111	433	12	266	7	00000398_0300181Eh
0010000	433	12	333	9	00000498_03001820h
0010001	433	12	400	11	00000598_03001822h
0010010	466	13	266	7	0000039A_03001824h
0010011	466	13	333	9	0000049A_03001826h
0010100	466	13	400	11	0000059A_03001828h
0010101	500	14	266	7	0000039C_0300182Ah
0010110	500	14	333	9	0000049C_0300182Ch
0010111	500	14	400	11	0000059C_0300182Eh
0011000	533	15	266	7	0000039E_03001830h
0011001	533	15	333	9	0000049E_03001832h
0011010	533	15	400	11	0000059E_030001834h
0011011	600	17	200	5	000002A2_03001836h
0011100	566	16	333	9	000004A0_03001838h
0011101	566	16	400	11	000005A0_0300183Ah
0011110	600	17	333	9	000004A2_0300003Ch
0011111	600	17	400	11	000005A2_0300183Eh

**Table 6-88. Bootstrap Bit Settings and Reset State of GLCP\_SYS\_RSTPLL (PW1 and IRQ13 vary)**

{PW1,IRQ13,PW0,SUSPA#,GNT#[2:0]} same as GLCP_SYS_RSTPLL[7:1]	CPU Speed	CORE MULT	GLIU Speed	GLIU MULT	GLCP_SYS_RSTPLL Reset Value
0100000	Bypass	11	Bypass	7	00000396_00001840h
1000001	166	4	166	4	00000249_03000082h
1110111	500	14	400	11	000005DD_030000EEh

**6.14.2.14 GLCP Dot Clock PLL Control (GLCP\_DOTPLL)**

MSR Address 4C000015h  
 Type R/W  
 Reset Value 000000D7\_02000000h

This register does not include hardware handshake controls like the GLCP\_SYS\_RSTPLL register (MSR 4C000014h), so care should be taken when changing the settings. For example, to change the DIV settings: write the register with the DOT-RESET bit (bit 0) set and either in the same write or another write change the DIV settings; read the register until the LOCK bit (bit 25) goes active (or until a timeout occurs, if desired); write the register with the same DIV settings and with the DOT-RESET bit clear. The MDIV, NDIV, and PDIV (bits [46:32]) settings work in conjunction to create the internal DOTCLK using this equation:

$$F_{out} = F_{in} \cdot \frac{(NDIV + 1)}{(MDIV + 1) \cdot (PDIV + 1)}$$

For example, with bits [46:32] in the GLCP\_DOTPLL register set to 0x00D7 (reset), the Dot clock frequency that the DC and VP would run with would be:

$$F_{out} = 14.318MHz \cdot \frac{(13 + 1)}{(0 + 1)(7 + 1)} = 25.0565MHz$$

However, not all MDIV, NDIV, and PDIV settings lock and not all that lock have good long-term jitter characteristics. The PLL resets to 25.0565 MHz for VGA monitors assuming a 14.31818 MHz input. A 27 MHz input will successfully lock at about 47 MHz, and should then be changed to the desired pixel rate.

**GLCP\_DOTPLL Register Map**

63	62	61	60	59	58	57	56	55	54	53	52	51	50	49	48	47	46	45	44	43	42	41	40	39	38	37	36	35	34	33	32
RSVD															DIV4	RSVD	MDIV			NDIV						PDIV					
31	30	29	28	27	26	25	24	23	22	21	20	19	18	17	16	15	14	13	12	11	10	9	8	7	6	5	4	3	2	1	0
SWFLAGS						LOCK	HALFPIX	RSVD								BYPASS	PD	CAPEN	RSVD						DOTRESET						

## GLCP\_DOTPLL Bit Descriptions

Bit	Name	Description
63:49	RSVD	<b>Reserved.</b> Write as read.
48	DIV4	<b>Divide by 4.</b> When set, the PLL output is divided by 4 before clocking the logic. This bit is intended for generating frequencies below the PLL spec limit of 15 MHz.
47	RSVD	<b>Reserved.</b>
46:44	MDIV	<b>Input Clock Divisor.</b> The DOTPLL M setting (resets to VGA timing).
43:36	NDIV	<b>Dot Clock PLL Divisor.</b> The DOTPLL N setting (resets to VGA timing).
35:32	PDIV	<b>Post Scaler Divisor.</b> The DOTPLL P setting (resets to VGA timing).
31:26	SWFLAGS	<b>Software Flags.</b> Unlike in the GLCP_SYS_RSTPLL register (MSR 4C000014h), these bits are reset to 0 by a soft reset to the chip. These bits are otherwise read/writable by software. They are not reset by a DOTRESET (bit 0 of this register).
25	LOCK (RO)	<b>Lock (Read Only).</b> Lock signal from the DOTCLK PLL.
24	HALFPIX	<b>Half Pixel.</b> The DC and VP receive a half-frequency Dot clock while the VOP logic receives the normal frequency determined by the MDIV, NDIV, PDIV settings. This feature enables 8-bit VOP of SD data at 27 MHz VOP clock (pixel rate only 13.5 MHz).
23:16	RSVD	<b>Reserved.</b> Write as read.
15	BYPASS	<b>Dot PLL Bypass.</b> This signal controls the bypass mode of the DOTCLK PLL. If this bit is high, the DOTREF input clock directly drives the raw DOTCLK, bypassing the MDIV, NDIV, and PDIV logic.
14	PD	<b>Power Down.</b> This bit controls the power down mode of the DOTCLK PLL. It is active high.
13	CAPEN	<b>Capacitor Enable.</b> The CAPEN signal to the DOTPLL enables an external capacitor for the loop filter. 0: An external capacitor is not used. Internal circuitry is used to stabilize the loop operation. 1: Enables the use of an external capacitor for the loop filter.
12:10	RSVD	<b>Reserved.</b>
9:1	RSVD	<b>Reserved.</b> Read/writable bits not currently used.
0	DOTRESET	<b>Dot Clock Reset.</b> The reset pin to the Dot clock time blocks. The Dot reset is held active when CHIP_RESET (MSR 4C000014h[0]) is high, but this bit resets to 0. It is recommended that software set this bit when changing PLL settings and observe LOCK before releasing this reset. Unlike the SYS_RSTPLL register, this bit is not required to be set before the other bits in this register affect the PLL.

**6.14.2.15 GLCP Debug Clock Control (GLCP\_DBGCLKCTL)**

MSR Address 4C000016h  
 Type R/W  
 Reset Value 00000000\_00000002h

Note that after the mux to select the clock, a standard clock control gate exists. This register should never be changed from one non-zero value to another. Always write this register to 0 when moving to an alternative debug clock.

**GLCP\_DBGCLKCTL Register Map**

63	62	61	60	59	58	57	56	55	54	53	52	51	50	49	48	47	46	45	44	43	42	41	40	39	38	37	36	35	34	33	32
RSVD																															
31	30	29	28	27	26	25	24	23	22	21	20	19	18	17	16	15	14	13	12	11	10	9	8	7	6	5	4	3	2	1	0
RSVD																											CLKSEL				

**GLCP\_DBGCLKCTL Bit Descriptions**

Bit	Name	Description
63:3	RSVD	<b>Reserved.</b> Write as read.
2:0	CLKSEL	<b>Clock Select.</b> Selects the clock to drive into the debug logic. 000: None. 001: CPU Core clock. 010: GLIU1 clock. 011: DOTCLK. 100: PCI clock. 101-111: Reserved.

**6.14.2.16 Chip Revision ID (GLCP\_CHIP\_REVID)**

MSR Address 4C000017h  
 Type RO  
 Reset Value 00000000\_000000xxh

**GLCP\_CHIP\_REVID Register Map**

63	62	61	60	59	58	57	56	55	54	53	52	51	50	49	48	47	46	45	44	43	42	41	40	39	38	37	36	35	34	33	32
RSVD																															
31	30	29	28	27	26	25	24	23	22	21	20	19	18	17	16	15	14	13	12	11	10	9	8	7	6	5	4	3	2	1	0
RSVD																								MAJ						MIN	

**GLCP\_CHIP\_REVID Bit Descriptions**

Bit	Name	Description
63:8	RSVD	<b>Reserved.</b> Reads as 0.
7:4	MAJ	<b>Major Revision.</b> Identifies major silicon revision. See <i>AMD Geode™ LX Processors Specification Update</i> document for value.
3:0	MIN	<b>Minor Revision.</b> Identifies minor silicon revision. See <i>AMD Geode™ LX Processors Specification Update</i> document for value.

**6.14.2.17 GLCP Control (GLCP\_CNT)**

MSR Address 4C000018h  
 Type R/W - I/O Offset 00h  
 Reset Value 00000000\_000000Fh

This register is used in conjunction with GLIU1 Power Management. I/O writes, which include the lowest byte of this register, may trigger an SMI if GLD\_MSR\_SMI (MSR 4C002002h) is configured appropriately. MSR writes do not cause SMIs. The throttle sequence starts after the delay specified by GLCP\_TH\_SD (MSR 4C00001Ch), which can allow for SMI handling time or any other preparations. Throttling is temporarily stopped in IRQ, SSMI, ASMI, or DMI. NMI and system sleep (C2) always clear THT\_EN (bit 4).

**GLCP\_CNT Register Map**

63	62	61	60	59	58	57	56	55	54	53	52	51	50	49	48	47	46	45	44	43	42	41	40	39	38	37	36	35	34	33	32
RSVD																															
31	30	29	28	27	26	25	24	23	22	21	20	19	18	17	16	15	14	13	12	11	10	9	8	7	6	5	4	3	2	1	0
RSVD																											THT_EN	CLK_VAL			

**GLCP\_CNT Bit Descriptions**

Bit	Name	Description
63:5	RSVD	<b>Reserved.</b> Write as read.
4	THT_EN	<b>Throttle Enable.</b> When high, enables throttling of processor for power management. This bit is always cleared by an NMI to the processor or when system sleep initiates, it may clear from an SMI or IRQ depending on GLCP_TH_OD (MSR 4C00001Eh) settings.
3:0	CLK_VAL	<b>Clock Throttling Value.</b> The value 0000 is reserved and should not be used. The value 0001 yields the most throttling while the value 1111 has the effect of no throttling (1111 is the reset value). Reads return value written. THT_EN (bit 4) must be low to change the value of CLK_VAL. See also GLCP_TH_SF (MSR 4C00001Dh). During processor throttling, processor suspend is applied the amount of time of “(15-CLK_VAL)*GLCP_TH_SF” and then removed the amount of time of “CLK_VAL*GLCP_TH_SF”.

**6.14.2.18 GLCP Level 2 (GLCP\_LVL2)**

MSR Address 4C000019h  
 Type R/W - I/O Offset 04h  
 Reset Value 00000000\_00000000h

This register has no writable bits. I/O reads to the lower byte of this register (with or without reading the other three bytes) return 0 and cause the system to enter “C2 processor state” as defined by the GLIU1 power management spec; that is, suspend the processor. I/O reads to the lower byte of this register may trigger an SMI if GLD\_MSR\_SMI (MSR 4C002002h) is configured appropriately. Note that the suspend starts after a delay specified by GLCP\_TH\_SD (MSR 4C00001Ch), which can allow for SMI handling or any other preparations. P\_LVL2\_IN (MSR 4C00001Ch[12]) can abort the suspend operation. MSR reads to this register return 0, but perform no further action.



**6.14.2.19 GLCP Throttle or C2 Start Delay (GLCP\_TH\_SD)**

MSR Address 4C00001Ch  
 Type R/W - I/O Offset 10h  
 Reset Value 00000000\_00000000h

**GLCP\_TH\_SD Register Map**

63	62	61	60	59	58	57	56	55	54	53	52	51	50	49	48	47	46	45	44	43	42	41	40	39	38	37	36	35	34	33	32
RSVD																															
31	30	29	28	27	26	25	24	23	22	21	20	19	18	17	16	15	14	13	12	11	10	9	8	7	6	5	4	3	2	1	0
RSVD																			P_LVL2_IN	THT_DELAY											

**GLCP\_TH\_SD Bit Descriptions**

Bit	Name	Description
63:13	RSVD	<b>Reserved.</b> By convention, always write zero.
12	P_LVL2_IN	<b>Enable Indicator.</b> If P_LVL2 (in MSR 4C000019h) was read, then this bit reads high. If this bit is written to a one, the suspend is aborted. This bit is always cleared and Suspend de-asserted on NMI, IRQ, SSMI, ASMI, DMI, or system Sleep.
11:0	THT_DELAY	<b>Throttle Delay.</b> Indicates how long to wait before beginning the processor throttling process as defined by MSR 4C000018h. The delay setting is multiplied by 16 to get the number of PCI clock cycles to wait, thus setting THT_DELAY = 3 causes a wait of 48 PCI clock cycles.

**6.14.2.20 GLCP Scale Factor (GLCP\_TH\_SF)**

MSR Address 4C00001Dh  
 Type R/W - I/O Offset 14h  
 Reset Value 00000000\_00000000h

**GLCP\_TH\_SF Register Map**

63	62	61	60	59	58	57	56	55	54	53	52	51	50	49	48	47	46	45	44	43	42	41	40	39	38	37	36	35	34	33	32
RSVD																															
31	30	29	28	27	26	25	24	23	22	21	20	19	18	17	16	15	14	13	12	11	10	9	8	7	6	5	4	3	2	1	0
RSVD																							SCALE								

**GLCP\_TH\_SF Bit Descriptions**

Bit	Name	Description
63:8	RSVD	<b>Reserved.</b> By convention, always write 0.
7:0	SCALE	<b>Scale Factor.</b> This value is used in conjunction with CLK_VAL in the GLCP_CNT MSR (4C000018h[3:0]). This value times CLK_VAL (or 15-CLK_VAL) indicates the number of PCI clock cycles to wait during processor active (or suspend) periods. The setting is multiplied by 16 to get the number of PCI clock cycles per period, thus SCALE = 3 and CLK_VAL = 5 will have the processor active for 240 PCI clocks and suspended for 480 PCI clocks.

### 6.14.2.21 GLCP Processor Throttle Off Delay (GLCP\_TH\_OD)

MSR Address 4C00001Eh  
 Type R/W - I/O Offset 18h  
 Reset Value 00000000\_00000000h

**GLCP\_TH\_OD Register Map**

63	62	61	60	59	58	57	56	55	54	53	52	51	50	49	48	47	46	45	44	43	42	41	40	39	38	37	36	35	34	33	32	
RSVD																																
31	30	29	28	27	26	25	24	23	22	21	20	19	18	17	16	15	14	13	12	11	10	9	8	7	6	5	4	3	2	1	0	
RSVD																IRQ_EN	SMI_EN	OFF_DELAY														

**GLCP\_TH\_OD Bit Descriptions**

Bit	Name	Description
63:16	RSVD	<b>Reserved.</b> By convention, always write 0.
15	IRQ_EN	<b>Enable Throttling Restart after IRQ.</b> If this bit is set and throttling is not disabled during the IRQ handling, throttling restarts after the period specified by OFF_DELAY (bits [13:0]). If this bit is clear, then an IRQ clears THT_EN (MSR 4C000018h[4]).
14	SMI_EN	<b>Enable Throttling Restart after SMI.</b> If this bit is set and throttling is not disabled during the SMI handling, throttling restarts after the period specified by OFF_DELAY (bits [13:0]) If this bit is clear, then an ASMI clears THT_EN (MSR 4C000018h[4]).
13:0	OFF_DELAY	<b>Throttle Off Delay.</b> Indicates the period to wait from receipt of IRQ_EN (bit 15) or SMI_EN (bit 14) before restarting throttle operation. This setting is multiplied by 16 to get the number of PCI clock cycles to wait. If the OFF_DELAY has not expired and another IRQ or SMI occurs, the OFF_DELAY timer is cleared again and the wait begins again. Setting OFF_DELAY to 0 results in only one PCI clock cycle of throttling being disabled after an IRQ or SMI.

### 6.14.3 GLCP IGNNE I/Os

GLCP I/O Offset F0h, F1h  
 Type W  
 Reset Value NA

The GLCP's GLIU is responsible for all the GLIU functionality. The GLCP's GLIU implements a large MSR space consisting of the required standard GLIU device MSRs, MSR controls for clock and PLL interfacing, the MSR controls for the I/O companion modes and MVPI signals, and MSR controls for the debug logic. The GLCP's GLIU must properly decode all possible GLIU transaction types including the unexpected addresses, request types and sizes. It must respond with the proper number of response packets. In addition, it provides error logic to detect unexpected addresses and types.

The GLCP's GLIU also implements the processor floating point exception handling logic.

```

always @(va_ferr or irq13 or write_to_F0F1 or ignee)
  if (!va_ferr) nxt_ignne = 0;
  else if (irq13 && write_to_F0F1) nxt_ignne = 1;
  else nxt_ignne = ignne;
always @(posege ck)
  ignee <= nxt_ignne;
  irq13 <= va_ferr & !nxt_ignne;

```

The GLCP's GLIU maintains MSRs that control the source and value of the companion device system outputs. It also controls the current companion device mode.

Read data returns GLD\_MSR\_CAP data.

#### 6.14.4 GLCP Specific MSRs - GLCP Debug Interface MSRs

##### 6.14.4.1 GLCP DAC (GLCP\_DAC)

MSR Address 4C000023h  
 Type R/W  
 Reset Value 00000000\_00000000h

This register has DAC diagnostic controls and status. It ties directly to inputs and outputs on the DAC module.

Bits [13:11] of this register are only valid after the DAC is enabled.

**GLCP\_DAC Register Map**

63	62	61	60	59	58	57	56	55	54	53	52	51	50	49	48	47	46	45	44	43	42	41	40	39	38	37	36	35	34	33	32
RSVD																															
31	30	29	28	27	26	25	24	23	22	21	20	19	18	17	16	15	14	13	12	11	10	9	8	7	6	5	4	3	2	1	0
RSVD																		SB	SG	SR	INREFEN	OL	AB			AG			AR		

**GLCP\_DAC Bit Descriptions**

Bit	Name	Description
64:14	RSVD	<b>Reserved.</b>
13	SB (RO)	<b>Status Blue (Read only).</b> A logic level 1 means the Blue DAC output is above 0.35V.
12	SG (RO)	<b>Status Green (Read only).</b> A logic level 1 means the Green DAC output is above 0.35V.
11	SR (RO)	<b>Status Red (Read only).</b> A logic level 1 means the Red DAC output is above 0.35V.
10	INREFEN	<b>Internal Reference Enable.</b> Internal reference enable to the DAC.
9	OL	<b>Output Level.</b> 0: RGB. 1: TV - for testing only, analog TV out is not supported).
8:6	AB	<b>Adjust for Blue DAC.</b> 000: 0%. 011: 7.5%. 100: -10%. 111: -2.5%.
5:3	AG	<b>Adjust for Green DAC.</b> 000: 0%. 011: 7.5%. 100: -10%. 111: -2.5%.
2:0	AR	<b>Adjust for Red DAC.</b> 000: 0%. 011: 7.5%. 100: -10%. 111: -2.5%.

**6.14.5 GLCP Specific MSRs - GLCP Companion Device Interface MSRs**

**6.14.5.1 CPU A20M Signal (MSR\_A20M)**

MSR Address 4C000031h  
 Type R/W  
 Reset Value 00000000\_00000000h

**MSR\_A20M Register Map**

63	62	61	60	59	58	57	56	55	54	53	52	51	50	49	48	47	46	45	44	43	42	41	40	39	38	37	36	35	34	33	32
RSVD																															
31	30	29	28	27	26	25	24	23	22	21	20	19	18	17	16	15	14	13	12	11	10	9	8	7	6	5	4	3	2	1	0
RSVD																															MSR_A20M

**MSR\_A20M Bit Descriptions**

Bit	Name	Description
63:1	RSVD	Reserved.
0	MSR_A20M	A20M. Value of A20M driven to CPU logic.

**6.14.5.2 CPU INIT Signal (MSR\_INIT)**

MSR Address 4C000033h  
 Type R/W  
 Reset Value 00000000\_00000000h

**MSR\_INIT Register Map**

63	62	61	60	59	58	57	56	55	54	53	52	51	50	49	48	47	46	45	44	43	42	41	40	39	38	37	36	35	34	33	32
RSVD																															
31	30	29	28	27	26	25	24	23	22	21	20	19	18	17	16	15	14	13	12	11	10	9	8	7	6	5	4	3	2	1	0
RSVD																															MSR_INIT

**MSR\_INIT Bit Descriptions**

Bit	Name	Description
63:1	RSVD	Reserved.
0	MSR_INIT	MSR_INIT. Value of INIT signal driven to CPU.

**6.14.5.3 GLIU Device Interrupt Status (MSR\_INTAX)**

MSR Address 4C000036h  
 Type RO  
 Reset Value 00000000\_00000000h

This is a read only MSR with the status of interrupt signals from the various blocks. This register is intended for debug purposes. For functional interrupt handlers, the block-specific interrupt registers are memory-mapped. For devices that do not support interrupts, the associated bit is 0.

**MSR\_INTAX Register Map**

63	62	61	60	59	58	57	56	55	54	53	52	51	50	49	48	47	46	45	44	43	42	41	40	39	38	37	36	35	34	33	32		
RSVD																																	
31	30	29	28	27	26	25	24	23	22	21	20	19	18	17	16	15	14	13	12	11	10	9	8	7	6	5	4	3	2	1	0		
RSVD																	GLIU1_INT6	GLIU1_INT5	GLIU1_INT4	GLIU1_INT3	GLIU1_INT2	GLIU1_INT1	GLIU1_INT0	RSVD	RSVD	GLIU0_INT5	GLIU0_INT4	GLIU0_INT3	GLIU0_INT2	GLIU0_INT1	GLIU0_INT0		

**MSR\_INTAX Bit Descriptions**

Bit	Name	Description
63:15	RSVD	Reserved.
14	GLIU1_INT6	Value of INTR signal from GLIU1, Port 6 (Security Block (AES)).
13	GLIU1_INT5	Value of INTR signal from GLIU1, Port 5 (VIP).
12	GLIU1_INT4	Value of INTR signal from GLIU1, Port 4 (GLPCI).
11	GLIU1_INT3	Value of INTR signal from GLIU1, Port 3 (GLCP).
10	GLIU1_INT2	Value of INTR signal from GLIU1, Port 2 (VP).
9	GLIU1_INT1	Value of INTR signal from GLIU1, Port 1 (GLIU).
8	GLIU1_INT0	Value of INTR signal from GLIU1, Port 0 (GLIU).
7	RSVD	Reserved.
6	RSVD	Reserved.
5	GLIU0_INT5	Value of INTR signal from GLIU0, Port 5 (GP).
4	GLIU0_INT4	Value of INTR signal from GLIU0, Port 4 (DC).
3	GLIU0_INT3	Value of INTR signal from GLIU0, Port 3 (CPU).
2	GLIU0_INT2	Value of INTR signal from GLIU0, Port 2 (GLIU)
1	GLIU0_INT1	Value of INTR signal from GLIU0, Port 1 (GLMC).
0	GLIU0_INT0	Value of INTR signal from GLIU0, Port 0 (GLIU).

## 6.15 GeodeLink™ PCI Bridge

The GeodeLink™ PCI Bridge (GLPCI) module provides a PCI interface for GeodeLink Interface Unit-based designs. The GLPCI module is composed of five major blocks:

- GeodeLink Interface
- FIFO/Synchronization
- Transaction Forwarding
- PCI Bus Interface
- PCI Arbiter

The GeodeLink and PCI Bus Interface blocks provide adaptation to the respective buses. The Transaction Forwarding block provides bridging logic.

### Features

- PCI Version 2.2 compliance
- 32-bit, 66 MHz PCI bus operation
- Target support for fast back-to-back transactions
- Arbiter support for three external PCI bus masters
- Write gathering and write posting for in-bound write requests
- Virtual PCI header support
- Delayed transactions for in-bound read requests
- Zero wait state operation within a PCI burst
- Dynamic clock stop/start support for GLIU and PCI clock domains (this is not CLKRUN support)
- Capable of handling out of bound transactions immediately after reset

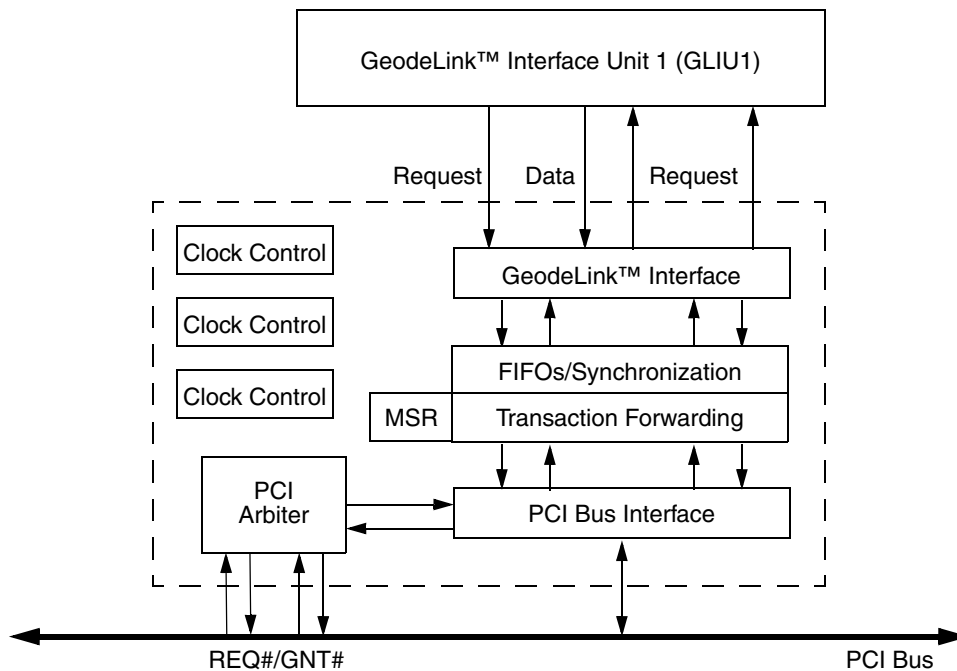


Figure 6-58. GLPCI Block Diagram

### 6.15.1 GeodeLink™ Interface Block

The GeodeLink Interface block provides a thin protocol conversion layer between the Transaction Forwarding block and GeodeLink Interface Unit 1 (GLIU1). It is responsible for multiplexing in-bound write request data with out-bound read response data on the single GLIU1 data out bus.

### 6.15.2 FIFO/Synchronization Block

The FIFO module consists of a collection of in-bound and out-bound FIFOs. Each FIFO provides simple, synchronous interfaces to read and write requests.

### 6.15.3 Transaction Forwarding Block

The Transaction Forwarding block receives, processes, and forwards transaction requests and responses between the GeodeLink Interface and PCI Bus Interface blocks. It implements the transaction ordering rules and performs write gathering and read prefetching as needed. It also performs the necessary translation between GLIU1 and PCI commands; except for the creation of PCI configuration cycles in response to I/O accesses of address 0CFCh. The Transaction Forwarding block also handles the conversion between 64-bit GLIU1 data paths and 32-bit PCI data paths.

Out-bound transactions are handled in a strongly ordered fashion. Some out-bound burst writes may be combined into a larger PCI transaction. This is accomplished by dynamically concatenating together contiguous bursts as they are streamed out in a PCI bus transaction. Single 32-bit WORD accesses are not gathered. It is anticipated that the processor generates the majority of out-bound requests. Out-bound memory writes will not be posted. Thus, any queued out-bound requests need NOT be flushed prior to handling an in-bound read request.

Dynamic concatenation of contiguous bursts may occur when reading the penultimate (next to last) data WORD from the out-bound write data FIFO. On that cycle, if a suitable request is available at the head of the out-bound request FIFO, the PCI burst will be extended.

In-bound requests are handled using slightly relaxed ordering. All in-bound writes are gathered as much as possible. Any partially gathered in-bound writes are flushed when a cache line boundary is reached. All in-bound writes are posted. Thus, any queued in-bound write data MUST be written to system memory prior to the processor receiving data for an out-bound read request. This is accomplished by sorting out-bound read response data amongst in-bound write data. Thus, a pending out-bound read request need not be deferred while posted in-bound write data is flushed. The out-bound read request may be performed on

the PCI bus at the same time that the in-bound write data is flowing through GLIU1.

When handling an in-bound read request, the intended size of the transfer is unknown. In-bound read requests for non-prefetchable addresses only fetch the data explicitly indicated in the PCI transaction. Thus, all in-bound read requests made to non-prefetchable addresses return at most a single 32-bit WORD. In-bound read requests made to prefetchable memory may cause more than a 32-bit WORD to be prefetched. The amount of data prefetched is configured via the read threshold fields of the CTRL model specific register of GLPCI\_CTRL (MSR 50002010h). Multiple read requests may be generated to satisfy the read threshold value.

In-bound read requests may pass posted in-bound write data when there is no address collision between the read request and the address range of the posted write data (different cache lines) and the read address is marked as being prefetchable.

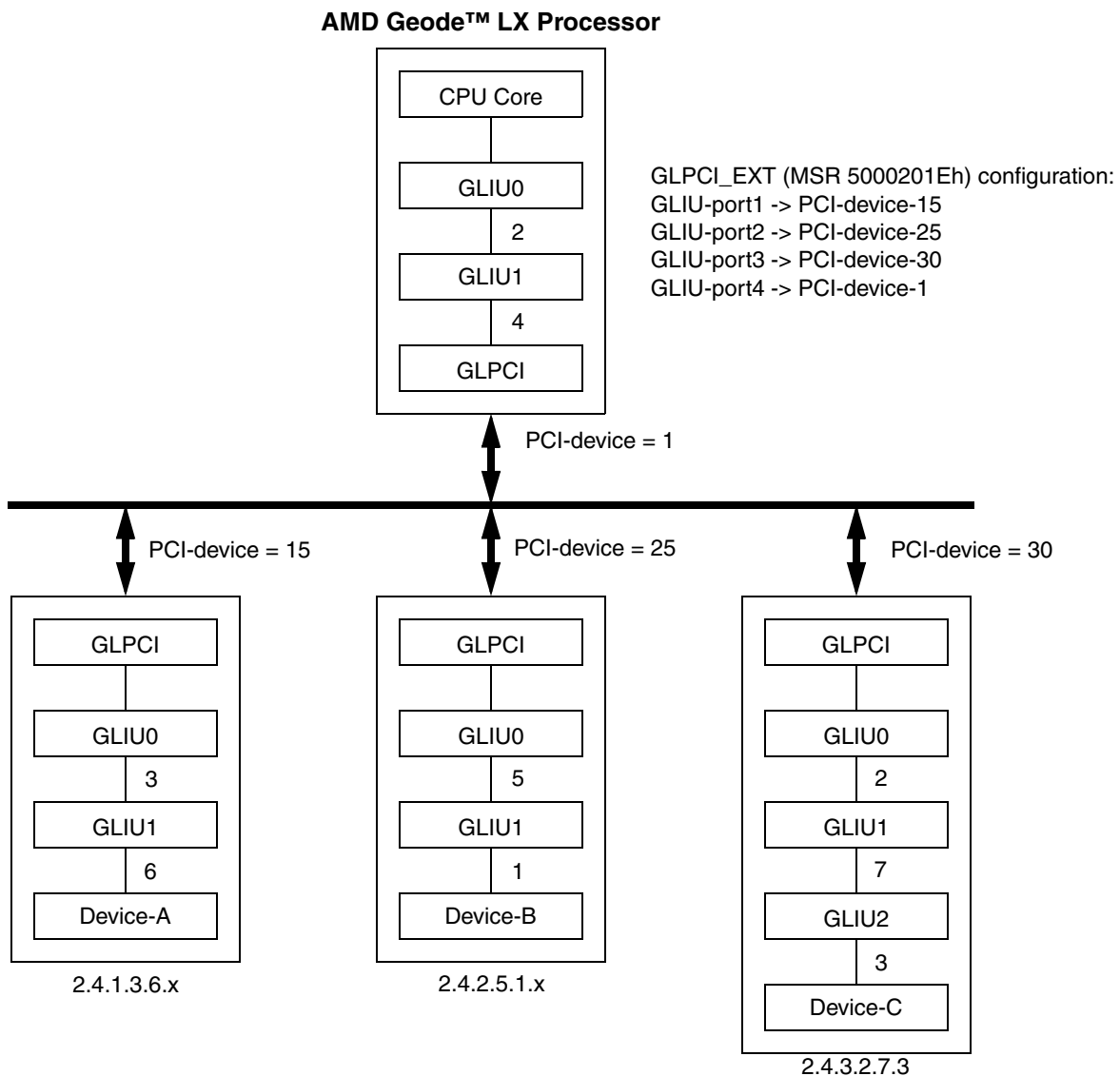
#### 6.15.3.1 Atomic External MSR Access

The companion device implements a mailbox scheme similar to the AMD Geode LX processor. To access internal model specific registers on the AMD Geode companion device's GLIU it is necessary to perform multiple PCI configuration cycles. The GLPCI module provides a mechanism to give software atomic, transparent access to the companion device's GLIU resident MSRs. It translates MSR read/writes received from the AMD Geode LX processor's GLIUs into the multiple PCI configuration needed to access the companion device's internal MSR. From software's point of view, the GLPCI module routes MSR read/write requests like a GLIU. The GLPCI module terminates MSR accesses where the three most significant bits are zero. Otherwise it uses the same three MSBs as an index to look up a PCI device number and a PCI function number in GLPCI\_EXT (MSR 5000201Eh). This device number is then further mapped onto AD[31:11] pins using the same mapping as with software generated PCI configuration cycles. Next the GLPCI module performs three PCI configuration bus cycles.

- Write MSR address to offset F4h
- Read/write MSR data to/from offset F8h
- Read/write MSR data to/from offset FCh

**Note:** The GLPCI module attempts to do a burst PCI configuration read or write. It is expected that the target PCI device will typically cause this burst to get broken up into two by performing a slave termination after each DWORD of data is transferred.

The GLPCI module can address up to seven external PCI devices in this manner.



**Figure 6-59. Atomic MSR Accesses Across the PCI Bus**



### 6.15.4 PCI Bus Interface Block

The PCI Bus Interface block is compliant to the PCI 2.2 specification, except in the handling of SERR#/PERR# signals. These signals are not available.

The PCI Bus Interface block provides a protocol conversion layer between the Transaction Forwarding block and the PCI bus. The master and target portions of this block operate independently. Thus, out-bound write requests and in-bound read responses are effectively multiplexed onto the PCI bus. It generates configuration cycles and software generated special cycles using the standard 0CF8h/0CFCh I/O address scheme. It includes address decoding logic to recognize distinct address regions for slave operation. Each address region is defined by a base address, a size, and some attached attributes (i.e., prefetchable, coherent).

This block is responsible for retrying out-bound requests when a slave termination without data is seen on the PCI bus. It must restart transactions on the PCI bus that are prematurely ended with a slave termination. This block always slave terminates in-bound read transactions issued to non-prefetchable regions after a single DWORD has been transferred.

The maximum inbound write throughput is only limited by the PCI latency timer (see register GLPCI\_CTRL bits [39:35]), which will interrupt an inbound transaction after the specified number of cycles. With this latency timer disabled (GLPCI\_CTRL bit 9), the maximum throughput is achieved

The maximum inbound read throughput is also affected by the PCI latency timer in a similar fashion to the inbound write throughput. It is also affected by the inbound read prefetch threshold setting (GLPCI\_CTRL bits [59:56]). With the latency timer disabled and the read prefetch set to 0Ah to 0Fh, the maximum throughput is achieved. With the read prefetch threshold set to the default of 04h, the throughput is not optimal.

#### 6.15.4.1 PCI Configuration and Virtual PCI Header Support

The PCI Bus Interface block implements the logic to generate PCI configuration cycles. The standard mechanism for generating PCI configuration cycles (as described in the PCI 2.2 specification) is used.

To access the internal PCI configuration registers of the AMD Geode LX processor, the Configuration Address register (CONFIG\_ADDRESS) must be written as a DWORD using the format shown in Table 6-89. Any other size will be interpreted as an I/O write to Port 0CF8h. Also, when entering the Configuration Index, only the six most significant bits of the offset are used, and the two least significant bits must be 00.

BYTE and WORD sized I/O accesses to 0CF8h pass through the PCI Bus Interface block onto the PCI bus. Writes to the CONFIG\_DATA register are translated into PCI configuration write bus cycles. Reads to the CONFIG\_DATA register are translated into PCI configuration read bus cycles. Bit 31 of the CONFIG\_ADDRESS register gates the translation of I/O accesses to 0CFCh into PCI configuration cycles.

IDSEL assertions are realized where device numbers 1 through 21 are mapped to the AD[11] through AD[31] pins.

In addition, support is included for virtualization of PCI buses and secondary bus devices. When a device or bus is virtualized, the PCI Bus Interface block generates a synchronous SMI for access to the CONFIG\_DATA register instead of generating a configuration cycle on the PCI bus. See GLPCI\_PBUS (MSR register (MSR 50002012h[31:0])) for details on virtual PCI header support.

The PCI Bus Interface block can be configured to accept in-bound PCI configuration cycles. This is used as a debug method for indirectly accessing the internal model specific register from the PCI bus. When this capability is enabled, the PCI Bus Interface block responds to in-bound PCI configuration cycles that make the PCI Bus Interface block's IDSEL signal become asserted (expected to be device 1). In this case, the PCI Bus Interface block ignores writes and returns FFFFFFFFh for accesses to locations 00h through EFh of the PCI configuration space. This makes the PCI Bus Interface block invisible to PCI Plug&Play software.

**Table 6-89. Format for Accessing the Internal PCI Configuration Registers**

31	30	29	28	27	26	25	24	23	22	21	20	19	18	17	16	15	14	13	12	11	10	9	8	7	6	5	4	3	2	1	0
1	Reserved							0	0	0	0	0	0	0	0	0	0	0	0	0	0	0	0	Configuration Index						0	0

Table 6-90. PCI Device to AD Bus Mapping

PCI Device	AD Pin	PCI Device	AD Pin	PCI Device	AD Pin	PCI Device	AD Pin
0	N/A	8	18	16	26	24	N/A
1	11	9	19	17	27	25	N/A
2	12	10	20	18	28	26	N/A
3	13	11	21	19	29	27	N/A
4	14	12	22	20	30	28	N/A
5	15	13	23	21	31	29	N/A
6	16	14	24	22	N/A	30	N/A
7	17	15	25	23	N/A	31	N/A

### 6.15.5 PCI Arbiter

The PCI arbiter implements a fair arbitration scheme with special support for the companion device. By default it operates as a simple round-robin arbiter that rotates priority in circular fashion (see Figure 6-60). There are three external REQ#/GNT# pairs, numbered 0 through 2, and an internal REQ#/GNT# pair for the CPU. REQ2#/GNT2# is reserved for the AMD Geode companion device (i.e., southbridge).

Each requestor can be configured to be preemptable/non-preemptable (Figure 6-61), given a repeat-count attribute and given a grant-hold timeout attribute. The repeat-count and grant-hold attributes are present to help balance the fairness of the PCI bus when mixing bus masters of different bursting characteristics. For example, the companion device drops its REQ# signal after each grant and issues relatively small bursts, while some other bus masters present very long bursts on the PCI bus. When both bus masters are concurrently active, the companion device gets a very small share of the PCI bus. The repeat-count allows a bus master to retain control of the PCI bus across multiple bus tenures and the grant-hold keeps the grant asserted with an idle bus for a configurable number of clock cycles, giving the bus master a chance to reassert REQ# again. Together they allow a small bursting bus master, like the companion device, to repeatedly issue a sequence of bursts before being preempted, giving it fair access to PCI bandwidth even in the presence of a large bursting bus master (e.g., a modern network adapter). Use of the repeat-count attribute has an impact on the preemptability of the bus master. That master can only be preempted when working on its last repeated access to the bus. For example, if a bus master has a repeat-count of 2 it may only be preempted on its third access to the bus. The arbiter can be configured to temporarily override this non-preemptability, particular masters that are requesting access to the PCI bus.

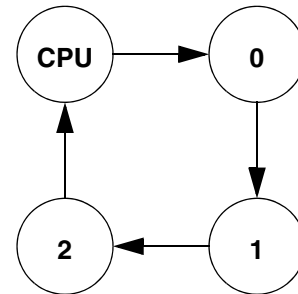


Figure 6-60. Simple Round-Robin

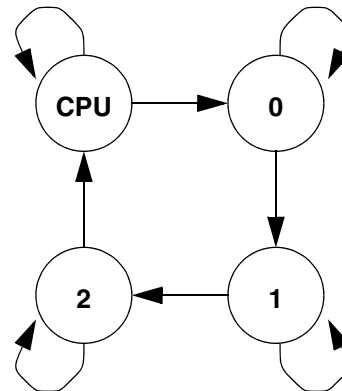


Figure 6-61. Weighted Round-Robin

## 6.15.6 Exception Handling

### 6.15.6.1 Out-Bound Write Exceptions

When performing an out-bound write on the PCI bus, two errors may occur: target abort and PERR# assertion. When a target abort occurs, the PCI Bus Interface block must flush any stored write data. It must then report the error. The assertion of PERR# is handled generically. The failed transaction will not be retried.

### 6.15.6.2 Out-Bound Read Exceptions

When performing an out-bound read on the PCI bus, two errors may occur: target abort and parity error. When a target abort occurs, the PCI Bus Interface block must return the expected amount of data with sufficient error signals.

### 6.15.6.3 In-Bound Write Exceptions

When performing an in-bound write from the PCI bus, two errors may occur: a detected parity error and a GLIU exception. A GLIU exception cannot be relayed back to the originating PCI bus master because in-bound PCI writes are always posted. When a parity error is detected, the PERR# signal must be asserted by the PCI Bus Interface block. However, the corrupted write data will be passed along to the GLIU.

### 6.15.6.4 In-Bound Read Exceptions

When performing an in-bound read from the GLIU, the EXCEP flag may be set on any received bus-WORD of data. This may be due to an address configuration error caused by software or by an error reported by the source of data. The asynchronous ERR and/or SMI bit will be set by the PCI Bus Interface block and the read data, valid or not, will be passed to the PCI Interface block along with the associated exceptions. The PCI Bus Interface block should simply pass the read response data along to the PCI bus.

## 6.16 GeodeLink™ PCI Bridge Register Descriptions

All GeodeLink™ PCI Bridge (GLPCI) registers are Model Specific Registers (MSRs) and are accessed via the RDMSR and WRMSR instructions.

The registers associated with the GLPCI are the Standard GeodeLink Device (GLD) MSRs and GLPCI Specific MSRs. Table 6-91 and Table 6-92 are register summary

tables that include reset values and page references where the bit descriptions are provided.

The MSR address is derived from the perspective of the CPU Core. See Section 4.1 "MSR Set" on page 45 for more detail on MSR addressing.

**Table 6-91. Standard GeodeLink™ Device MSRs Summary**

MSR Address	Type	Register Name	Reset Value	Reference
50002000h	RO	GLD Capabilities MSR (GLD_MSR_CAP)	00000000_001054xxh	Page 574
50002001h	R/W	GLD Master Configuration MSR (GLD_MSR_CONFIG)	00000000_00000000h	Page 574
50002002h	R/W	GLD SMI MSR (GLD_MSR_SMI)	00000000_0000003Fh	Page 575
50002003h	R/W	GLD Error MSR (GLD_MSR_ERROR)	00000000_0000003Fh	Page 576
50002004h	R/W	GLD Power Management MSR (GLD_MSR_PM)	00000000_00000015h	Page 577
50002005h	R/W	GLD Diagnostic MSR (GLD_MSR_DIAG)	00000000_00000000h	Page 577

**Table 6-92. GLPCI Specific Registers Summary**

MSR Address	Type	Register Name	Reset Value	Reference
50002010h	R/W	GLPCI Global Control (GLPCI_CTRL)	44000000_00000000h	Page 578
50002011h	R/W	GLPCI Arbiter Control (GLPCI_ARB)	00000000_00000000h	Page 581
50002012h	R/W	GLPCI VPH / PCI Configuration Cycle Control (GLPCI_PBUS)	00FF0000_00000000h	Page 584
50002013h	R/W	GLPCI Debug Packet Configuration (GLPCI_DEBUG)	00000000_00000000h	Page 584
50002014h	R/W	GLPCI Fixed Region Enables (GLPCI_REN)	00000000_00000000h	Page 584
50002015h	R/W	GLPCI Fixed Region Configuration A0-BF (GLPCI_A0)	00000000_00000000h	Page 585
50002016h	R/W	GLPCI Fixed Region Configuration C0-DF (GLPCI_C0)	00000000_00000000h	Page 586
50002017h	R/W	GLPCI Fixed Region Configuration E0-FF (GLPCI_E0)	00000000_00000000h	Page 587
50002018h	R/W	GLPCI Memory Region 0 Configuration (GLPCI_R0)	00000000_00000000h	Page 588
50002019h	R/W	GLPCI Memory Region 1 Configuration (GLPCI_R1)	00000000_00000000h	Page 589
5000201Ah	R/W	GLPCI Memory Region 2 Configuration (GLPCI_R2)	00000000_00000000h	Page 590
5000201Bh	R/W	GLCPI Memory Region 3 Configuration (GLPCI_R3)	00000000_00000000h	Page 591
5000201Ch	R/W	GLCPI Memory Region 4 Configuration (GLPCI_R4)	00000000_00000000h	Page 592

**Table 6-92. GLPCI Specific Registers Summary**

<b>MSR Address</b>	<b>Type</b>	<b>Register Name</b>	<b>Reset Value</b>	<b>Reference</b>
5000201Dh	R/W	GLPCI Memory Region 5 Configuration (GLPCI_R5)	00000000_00000000h	Page 593
5000201Eh	R/W	GLPCI External MSR Access Configuration (GLPCI_EXT_MSR)	00000000_00000000h	Page 594
5000201Fh	R/W	GLPCI Spare	00000000_00000000h	Page 595
50002020h	R/W	GLPCI General Purpose I/O (GLPCI_GPIO)	00000000_00000000h	Page 596

**6.16.1 Standard GeodeLink™ Device (GLD) MSRs**

**6.16.1.1 GLD Capabilities MSR (GLD\_MSR\_CAP)**

MSR Address 50002000h  
 Type RO  
 Reset Value 00000000\_001054xxh

**GLD\_MSR\_CAP Register Map**

63	62	61	60	59	58	57	56	55	54	53	52	51	50	49	48	47	46	45	44	43	42	41	40	39	38	37	36	35	34	33	32
RSVD																															
31	30	29	28	27	26	25	24	23	22	21	20	19	18	17	16	15	14	13	12	11	10	9	8	7	6	5	4	3	2	1	0
RSVD								DEV_ID																REV_ID							

**GLD\_MSR\_CAP Bit Descriptions**

Bit	Name	Description
63:24	RSVD	<b>Reserved.</b> Reserved for future use.
23:8	DEV_ID	<b>Device ID.</b> Identifies device (1054h).
7:0	REV_ID	<b>Revision ID.</b> Identifies device revision. See <i>AMD Geode™ LX Processors Specification Update</i> document for value.

**6.16.1.2 GLD Master Configuration MSR (GLD\_MSR\_CONFIG)**

MSR Address 50002001h  
 Type R/W  
 Reset Value 00000000\_00000000h

**GLD\_MSR\_CONFIG Register Map**

63	62	61	60	59	58	57	56	55	54	53	52	51	50	49	48	47	46	45	44	43	42	41	40	39	38	37	36	35	34	33	32
RSVD																															
31	30	29	28	27	26	25	24	23	22	21	20	19	18	17	16	15	14	13	12	11	10	9	8	7	6	5	4	3	2	1	0
RSVD																								PRI			RSVD	PID			

**GLD\_MSR\_CONFIG Bit Descriptions**

Bit	Name	Description
63:7	RSVD (RO)	<b>Reserved (Read Only).</b> Reserved for future use.
6:4	PRI	<b>Priority.</b> Default priority.
3	RSVD (RO)	<b>Reserved (Read Only).</b> Reserved for future use.
2:0	PID	<b>Priority ID.</b> Assigned priority domain.

**6.16.1.3 GLD SMI MSR (GLD\_MSR\_SMI)**

MSR Address 50002002h  
 Type R/W  
 Reset Value 00000000\_0000003Fh

**GLD\_MSR\_SMI Register Map**

63	62	61	60	59	58	57	56	55	54	53	52	51	50	49	48	47	46	45	44	43	42	41	40	39	38	37	36	35	34	33	32
RSVD																															
31	30	29	28	27	26	25	24	23	22	21	20	19	18	17	16	15	14	13	12	11	10	9	8	7	6	5	4	3	2	1	0
RSVD										PARE	SYSE	VPHE	BME	TARE	MARE	RSVD										PARM	SYSM	VPHM	BMM	TARM	MARM

**GLD\_MSR\_SMI Bit Descriptions**

Bit	Name	Description
63:22	RSVD (RO)	<b>Reserved (Read Only).</b> Reserved for future use.
21	PARE	<b>Parity Error Event (Read/Write-1-to-Clear).</b> This bit is asserted due to detection of a PCI bus parity error. Write 1 to clear. PS (MSR 50002010h[27]) must be set to enable this event. The event causes an ASMI if PARM (bit 5) is cleared.
20	SYSE	<b>System Error Event (Read/Write-1-to-Clear).</b> This bit is asserted due to the detection of a PCI bus system error. Write 1 to clear. PS (MSR 50002010h[27]) must be set to enable this event. The event causes an ASMI if SYSM (bit 4) is cleared.
19	VPHE	<b>Virtual PCI Header Event (Read/Write-1-to-Clear).</b> This bit is set by Virtual PCI Header support logic, write 1 to clear. The event causes an SSMI if VPHM (bit 3) is cleared.
18	BME	<b>Broken Master Event (Read/Write-1-to-Clear).</b> This bit is asserted due to detection of a broken PCI bus master. Write 1 to clear. BMS (MSR 50002010h[26]) must be set to enable this event. The event causes an ASMI if BMM (bit 2) is cleared.
17	TARE	<b>Target Abort Received Event (Read/Write-1-to-Clear).</b> This bit is asserted due to reception of target abort on PCI. Write 1 to clear. TARS (MSR50002010h[25]) must be set to enable this event. The event causes an ASMI if TARM (bit 1) is cleared.
16	MARE	<b>Master Abort Received Event (Read/Write-1-to-Clear).</b> This bit is asserted due to reception of master abort on PCI. Write 1 to clear. MARS (MSR 50002010h[24]) must be set to enable this event. The event causes an ASMI if MARM (bit 0) is cleared.
15:6	RSVD	<b>Reserved.</b> Reserved for future use.
5	PARM	<b>Parity Error Mask.</b> Clear to allow PARE (bit 21) to generate an ASMI.
4	SYSM	<b>System Error Mask.</b> Clear to allow SYSE (bit 20) to generate an ASMI.
3	VPHM	<b>Virtual PCI Header Mask.</b> Clear to allow SSMI flag to be set in selected GLIU response packets. I/O reads and writes to location 0CFCh may cause an SSMI depending upon the configuration of this bit and the GLPCI_PBUS (MSR 50002012h) model specific registers.
2	BMM	<b>Broken Master Mask.</b> Clear to allow BME (bit 18) to generate an ASMI.
1	TARM	<b>Target Abort Received Mask.</b> Clear to allow TARE (bit 17) to generate an ASMI.
0	MARM	<b>Master Abort Received Mask.</b> Clear to allow MARE (bit 16) to generate an ASMI.

**6.16.1.4 GLD Error MSR (GLD\_MSR\_ERROR)**

MSR Address 50002003h  
 Type R/W  
 Reset Value 00000000\_0000003Fh

**GLD\_MSR\_ERROR Register Map**

63	62	61	60	59	58	57	56	55	54	53	52	51	50	49	48	47	46	45	44	43	42	41	40	39	38	37	36	35	34	33	32
RSVD																															
31	30	29	28	27	26	25	24	23	22	21	20	19	18	17	16	15	14	13	12	11	10	9	8	7	6	5	4	3	2	1	0
RSVD										PARE	SYSE	RSVD	BME	TARE	MARE	RSVD										PARM	SYSM	RSVD	BMM	TARM	MARM

**GLD\_MSR\_ERROR Bit Descriptions**

Bit	Name	Description
63:22	RSVD (RO)	<b>Reserved (Read Only).</b> Reserved for future use.
21	PARE	<b>Parity Error Event (Read/Write-1-to-Clear).</b> This bit is asserted due to detection of a PCI bus parity error. Write 1 to clear. PE (MSR 50002010h[31]) must be set to enable this event. The event causes an ERR if PARM (bit 5) is cleared.
20	SYSE	<b>System Error Event (Read/Write-1-to-Clear).</b> This bit is asserted due to the detection of a PCI bus system error. Write 1 to clear. PE (MSR 50002010h[31]) must be set to enable this event. The event causes an ERR if SYSM (bit 4) is cleared.
19	RSVD (RO)	<b>Reserved (Read Only).</b> Reserved for future use.
18	BME	<b>Broken Master Event (Read/Write-1-to-Clear).</b> This bit is asserted due to detection of a broken PCI bus master. Write 1 to clear. BME (MSR 50002010h[30]) must be set to enable this event. The event causes an ERR if BMM (bit 2) is cleared.
17	TARE	<b>Target Abort Received Event (Read/Write-1-to-Clear).</b> This bit is asserted due to the reception of a target abort on PCI. Write 1 to clear. TARE (MSR 50002010h[29]) must be set to enable this event. The event causes an ERR if TARM (bit 1) is cleared.
16	MARE	<b>Master Abort Received Event (Read/Write-1-to-Clear).</b> This bit is asserted due to the reception of a master abort on PCI. Write 1 to clear. MARE (MSR 50002010h[28]) must be set to enable this event. The event causes an ERR if MARM (bit 0) is cleared.
15:6	RSVD (RO)	<b>Reserved (Read Only).</b> Reserved for future use.
5	PARM	<b>Parity Error Mask.</b> Clear to allow PARE (bit 21) to generate an ERR.
4	SYSM	<b>System Error Mask.</b> Clear to allow SYSE (bit 20) to generate an ERR.
3	RSVD (RO)	<b>Reserved (Read Only).</b> Reserved for future use.
2	BMM	<b>Broken Master Mask.</b> Clear to allow BME (bit 18) to generate an ERR.
1	TARM	<b>Target Abort Received Mask.</b> Clear to allow TARE (bit 17) to assert ERR.
0	MARM	<b>Master Abort Received Mask.</b> Clear to allow MARE (bit 16) to assert ERR.



**6.16.1.5 GLD Power Management MSR (GLD\_MSR\_PM)**

MSR Address 50002004h  
 Type R/W  
 Reset Value 00000000\_00000015h

**GLD\_MSR\_PM Register Map**

63	62	61	60	59	58	57	56	55	54	53	52	51	50	49	48	47	46	45	44	43	42	41	40	39	38	37	36	35	34	33	32
RSVD																															
31	30	29	28	27	26	25	24	23	22	21	20	19	18	17	16	15	14	13	12	11	10	9	8	7	6	5	4	3	2	1	0
RSVD																											PM2	RSVD	PM1	RSVD	PM0

**GLD\_MSR\_PM Bit Descriptions**

Bit	Name	Description
63:5	RSVD (RO)	<b>Reserved (Read Only).</b> Reserved for future use.
4	PM2	<b>Power Mode 2.</b> Power mode for PCI-fast clock domain. 0: Disable clock gating. Clocks are always ON. 1: Enable active hardware clock gating.
3	RSVD (RO)	<b>Reserved (Read Only).</b> Reserved for future use.
2	PM1	<b>Power Mode 1.</b> Power mode for PCI clock domain. 0: Disable clock gating. Clocks are always ON. 1: Enable active hardware clock gating.
1	RSVD (RO)	<b>Reserved (Read Only).</b> Reserved for future use.
0	PM0	<b>Power Mode 0.</b> Power mode for GLIU clock domain. 0: Disable clock gating. Clocks are always ON. 1: Enable active hardware clock gating.

**6.16.1.6 GLD Diagnostic MSR (GLD\_MSR\_DIAG)**

MSR Address 50002005h  
 Type R/W  
 Reset Value 00000000\_00000000h

This register is for AMD use only and should not be written to.

6.16.2 GLPCI Specific Registers

6.16.2.1 GLPCI Global Control (GLPCI\_CTRL)

MSR Address 50002010h  
 Type R/W  
 Reset Value 44000000\_00000000h

GLPCI\_CTRL Register Map

63	62	61	60	59	58	57	56	55	54	53	52	51	50	49	48	47	46	45	44	43	42	41	40	39	38	37	36	35	34	33	32	
FTH				RTH				SBRTH				RTL				DTL				WTO		SLTO	ILTO		LAT				0			
31	30	29	28	27	26	25	24	23	22	21	20	19	18	17	16	15	14	13	12	11	10	9	8	7	6	5	4	3	2	1	0	
PE	BME	TARE	MARE	PS	BMS	TARS	MARS	SUS				IRFT		IRFC		IOD				ST	ER	RHE	LDE	RUPO	BZ	NI	ISO	OWC	IWC	PCD	IE	ME

GLPCI\_CTRL Bit Descriptions

Bit	Name	Description
63:60	FTH	<b>In-Bound Flush Threshold.</b> Controls the timing for requesting new read data while concurrently flushing previously prefetched, stale read data. If the number of prefetched 64-bit WORDs reaches this level then a pending request will be made.
59:56	RTH	<b>In-Bound Read Threshold.</b> Controls the timing for prefetching read data. If the number of prefetched 32-bit WORDs reaches this threshold, a subsequent GLIU request will be generated to fetch the next cache line of read data.
55:52	SBRTH	<b>Southbridge In-Bound Read Threshold.</b> Controls the timing for prefetching read data for the AMD Geode™ companion device. If the number of prefetched 32-bit WORDs reaches this threshold, a subsequent GLIU request will be generated to fetch the next cache line of read data. The status of the companion device's GNT# pin (GNT2#) is sampled to determine when the companion device is generating an in-bound request.
51:49	RTL	<b>Retry Transaction Limit.</b> Limits the number of out-bound retries. If a target signals retry indefinitely, the PCI interface may be configured to abort the failing out-bound request. 000: No limit 001: 8 retries 010: 16 retries 011: 32 retries 100: 64 retries 101: 128 retries 110: 256 retries 111: 512 retries
48:46	DTL	<b>Delayed Transaction Limit.</b> Limits the duration of delayed transactions. Once a read transaction is delayed (retried before the first data phase has completed) all other in-bound transactions are rejected until the original request is satisfied. If the original master stops retrying, a live-lock condition may occur. If the number of rejected transactions reaches the limit defined by this field, then the delayed transaction is forgotten. 000: No limit 001: 2 rejections 010: 4 rejections 011: 8 rejections 100: 16 rejections 101: 32 rejections 110: 64 rejections 111: 128 rejections
45:43	WTO	<b>In-Bound Write Timeout.</b> Controls the flushing of in-bound posted write data. When an in-bound write has completed on the PCI bus, an internal counter is loaded with a value derived from this field. It will then count down on each PCI clock edge. When the counter reaches 0, the posted write data is flushed to memory. 000: 4 PCI clock edge 001: 8 PCI clock edge 010: 16 PCI clock edge 011: 32 PCI clock edges 100: 64 PCI clock edges 101: 128 PCI clock edges 110: 256 PCI clock edges 111: No timeout

## GLPCI\_CTRL Bit Descriptions (Continued)

Bit	Name	Description
42	SLTO	<b>Subsequent Latency Timeout Select.</b> Specifies the subsequent target latency timeout limit. If within a burst, the GLPCI module does not respond with the configured number of clock ticks, the PCI interface will terminate the PCI bus cycle. 0: 8 PCI clock edges 1: 4 PCI clock edges
41:40	ILTO	<b>Initial Latency Timeout Select.</b> Specifies the initial target latency timeout limit for the PCI interface. If the GLPCI module does not respond with the first data phase within the configured number of clock edges, the PCI interface will terminate the PCI bus cycle. If AILTO (MSR 5000201Fh[6]) = 0 00: 32 PCI clock edges                      10: 8 PCI clock edges 01: 16 PCI clock edges                      11: 4 PCI clock edges If AILTO = 1 00: 64 PCI clock edges                      10: 256 PCI clock edges 01: 128 PCI clock edges                      11: No timeout
39:35	LAT	<b>PCI Latency Timer.</b> Latency timeout value for limiting bus tenure.
34:32	0 (RO)	<b>Constant 0 (Read Only).</b> The three least significant bits of the PCI latency timer field are fixed as zeros. These bits are not used as part of the PCI latency timer comparison.
31	PE	<b>PCI Error.</b> Allow detection of either a parity error or a system error to be reported in the PARE bit (MSR 50002003h[21]). 0: Disable. 1: Enable.
30	BME	<b>Broken Master Error.</b> Allow detection of a broken PCI bus master to be reported in the BME bit (MSR 50002003h[18]). 0: Disable. 1: Enable.
29	TARE	<b>Target Abort Received Error.</b> Allow reception of a PCI bus target abort to be reported in the TARE bit (MSR 50002003h[17]). 0: Disable. 1: Enable.
28	MARE	<b>Master Abort Received Error.</b> Allow reception of a PCI bus master abort to be reported in the MARE bit (MSR 50002003h[16]). 0: Disable. 1: Enable.
27	PS	<b>PCI ASMI.</b> Allow detection of either a parity error or a system error to be reported in the PARE bit (MSR 50002002h[21]). 0: Disable. 1: Enable.
26	BMS	<b>Broken Master ASMI.</b> Allow detection of a broken PCI bus master to be reported in the BME bit (MSR 50002002h[18]). 0: Disable. 1: Enable.
25	TARS	<b>Target Abort Received ASMI.</b> Allow reception of a PCI bus target abort to be reported in the TARE bit (MSR 50002002h[17]). 0: Disable. 1: Enable.

## GLPCI\_CTRL Bit Descriptions (Continued)

Bit	Name	Description
24	MARS	<b>Master Abort Receive ASMI.</b> Allow reception of a PCI bus master abort to be reported in the TARE bit (MSR 50002002h[17]). 0: Disable. 1: Enable.
23:21	SUS	<b>Busy Sustain.</b> Controls the sustain time for keeping the clocks running after the internal busy signals indicate that the clocks may be gated. 000: No sustain 001: 4 clock cycles 010: 8 clock cycles 011: 16 clock cycles 100: 32 clock cycles 101: 64 clock cycles 110: 128 clock cycles 111: 256 clock cycles
20:18	IRFT	<b>In-Bound Read Flush Timeout.</b> Controls the flushing of in-bound prefetch read data. When an in-bound read has completed on the PCI bus, an internal counter is loaded with a value derived from this field. It then counts down on each PCI clock edge. When the counter reaches 0, any remaining prefetched data is flushed. The counter stops counting down if a subsequent in-bound read is received. It continues to count down through an in-bound write and through any out-bound traffic. 000: 4 PCI clock edge 001: 8 PCI clock edges 010: 16 PCI clock edges 011: 32 PCI clock edges 100: 64 PCI clock edges 101: 128 PCI clock edges 110: 256 PCI clock edges 111: No timeout
17:16	IRFC	<b>In-Bound Read Flush Control.</b> Controls the policy for discarding stale data from in-bound read data FIFO. 00: Discard at end of in-bound read PCI transaction. 01: Discard upon timeout. 10: Discard at start of out-bound write or upon timeout. 11: Discard at start of out-bound write, at start of out-bound read or upon timeout. In addition to these policies, in-bound read data will be discarded whenever a non-contiguous in-bound read is accepted, or when an in-bound write is received that will affect the prefetched memory.
15:13	IOD	<b>I/O Delay.</b> Delay completion of out-bound I/O transactions for a configurable number of PCI clock cycles. 000: 0 PCI clock cycles 001: 1 PCI clock cycles 010: 2 PCI clock cycles 011: 4 PCI clock cycles 100: 8 PCI clock cycles 101: 16 PCI clock cycles 110: 32 PCI clock cycles 111: 64 PCI clock cycles
12	ST	<b>Short Timer.</b> When cleared to 0, delayed transactions are discarded after $2^{15}$ PCI clock cycles. When set to 1, delayed transactions are discarded after $2^5$ PCI clock cycles. For normal operation, this bit should be cleared.
11	ER	<b>Early Read.</b> When cleared to 0, out-bound reads are stalled until there is enough FIFO space in the out-bound read FIFO to hold data for the entire transaction. When set to 1, out-bound reads will start as soon as possible.
10	RHE	<b>Read Hints Enable.</b> When cleared to 0, all out-bound reads use PCI CMD = 6. When set to 1, the PCI CMD provides a hint about the size of the read request. 6: 1, 2 or 4 DWORDs E: 8 DWORDs

## GLPCI\_CTRL Bit Descriptions (Continued)

Bit	Name	Description
9	LDE	<b>Latency Disconnect Enable.</b> Writing 1, causes the PCI interface to disconnect from a PCI bus master when a latency timer expiration occurs. This enforces the configured minimum latency upon PCI bus masters where the GLPCI module is a target on the PCI bus. The latency timer must be greater than 0 when using this feature.
8	RUPO	<b>Relax Up-Stream Ordering.</b> Removes ordering restrictions for out-bound read response data with respect to in-bound write data. Setting this bit also causes the GLPCI to clear the SEND_RESPONSE flag for in-bound GLIU request packets. This bit should be cleared for normal operation.
7	BZ	<b>Bizarro Flag.</b> BIZARRO flag configuration to use on in-bound I/O reads and writes.
6	NI	<b>No Invalidate Flag.</b> Force the INVALIDATE flag to be cleared for all in-bound writes.
5	ISO	<b>In-Bound Strong Ordering.</b> Disables the ability of in-bound reads to coherently pass posted in-bound writes. When set to 1, a PCI read request received by the host bridge target is not forwarded to GLIU until all posted write data has been flushed to memory. This bit should be cleared for normal operation.
4	OWC	<b>Out-Bound Write Combining.</b> Enables concatenation of out-bound write bursts into a larger PCI burst. Setting this bit does NOT add any additional latency to out-bound writes.
3	IWC	<b>In-Bound Write Combining.</b> Enables combining of different in-bound PCI write transactions into a single GLIU host write transaction. When cleared to 0, PCI write data received from the host bridge target is not held in the posted write buffer; a GLIU transaction is generated immediately.
2	PCD	<b>In-Bound PCI Configuration Disable.</b> Disables the handling of in-bound PCI configuration cycles. When set to 1, PCI configuration cycles are not accepted by this PCI interface. After reset, the GLPCI module accepts in-bound PCI configuration cycles to provide a means of generating MSR transactions onto the internal GLIU. For normal operation this capability should be disabled.
1	IE	<b>I/O Enable.</b> Enable handling of in-bound I/O transactions from PCI. When set to 1, the PCI interface accepts all in-bound I/O transactions from PCI. This mode is only intended for design verification purposes. When cleared to 0, no in-bound I/O transactions are accepted.
0	ME	<b>Memory Enable.</b> Enable handling of in-bound memory access transaction from PCI. When cleared to 0 the PCI interface does not accept any in-bound memory transactions from the PCI bus. When set to 1, the PCI interface accepts in-bound memory transactions for those address ranges defined in the region configuration registers.

## 6.16.2.2 GLPCI Arbiter Control (GLPCI\_ARB)

MSR Address 50002011h  
 Type R/W  
 Reset Value 00000000\_00000000h

## GLPCI\_ARB Register Map

63	62	61	60	59	58	57	56	55	54	53	52	51	50	49	48	47	46	45	44	43	42	41	40	39	38	37	36	35	34	33	32	
CR				R2				R1				R0				CH				H2				H1				H0				
31	30	29	28	27	26	25	24	23	22	21	20	19	18	17	16	15	14	13	12	11	10	9	8	7	6	5	4	3	2	1	0	
RSVD								COV	OV2	OV1	OV0	RSVD	MSK2	MSK1	MSK0	RSVD				CPRE	PRE2	PRE1	PRE0	BM1	BMO	RSVD				EA	BMD	PARK

## GLPCI\_ARB Bit Definitions

Bit	Name	Description
63:60	CR	<b>CPU Repeat.</b> Controls the number of consecutive grants given to the CPU before rotating to the next requestor. This is only valid if there is a non-zero value for the CPU Hold-Grant control (CH, bits [47:44]). This may be overridden by either OV2, OV1 or OV0 (bits [22:20]). It is also ignored if the CPRE (bit 11) is cleared.
59:56	R2	<b>Request Repeat 2.</b> Controls the number of consecutive grants given to PCI requestor 2 before rotating to the next requestor. This is only valid if there is a non-zero value for the Request Hold-Grant2 control (H2, bits [43:40]). This may be overridden by either COV, OV1, or OV0 (bits [23,21,20]). It is also ignored if the ARB.PRE2 bit is cleared.
55:52	R1	<b>Request Repeat 1.</b> Controls the number of consecutive grants given to PCI requestor 1 before rotating to the next requestor. This is only valid if there is a non-zero value for the Request Hold-Grant1 control (H1, bits [39:36]). This may be overridden by either COV, OV2, or OV1 (bits [23,22,21]). It is also ignored if the PRE1 (bit 9) is cleared.
51:48	R0	<b>Request Repeat 0.</b> Controls the number of consecutive grants given to PCI requestor 0 before rotating to the next requestor. This is only valid if there is a non-zero value for the Request Hold-Grant0 control (H0, bits [35:32]). This may be overridden by either the ARB.COV, ARB.OV2 or ARB.OV1 controls. It is also ignored if PRE0 (bit 8) is cleared.
47:44	CH	<b>CPU Hold-Grant Controls.</b> Controls the number of PCI clock edges that the PCI bus must be idle after a CPU transaction before arbitration continues. This is only valid if there is a non-zero value for the CPU Repeat field (CR, bits [63:60]). This may be overridden by either OV2, OV1, or OV0 (bits [22,21,20]). It is also ignored if CPRE (bit 11) is cleared.
43:40	H2	<b>Request Hold-Grant 2.</b> Controls the number of PCI clock edges that the PCI bus must be idle after a requestor 2 transaction before arbitration continues. This is only valid if there is a non-zero value for the Request Repeat 2 field (R2, bits [59:56]). This may be overridden by either COV, OV1, or OV0 (bits [23,21,20]). It is also ignored if PRE2 (bit 10) is cleared.
39:36	H1	<b>Request Hold-Grant 1.</b> Controls the number of PCI clock edges that the PCI bus must be idle after a requestor 1 transaction before arbitration continues. This is only valid if there is a non-zero value for the Request Repeat 1 field (R1, bits [55:52]). This may be overridden by either COV, OV1, or OV0 (bits [23,21,20]). It is also ignored if the if PRE2 (bit 10) is cleared.
35:32	H0	<b>Request Hold-Grant 0.</b> Controls the number of PCI clock ticks that the PCI bus must be idle after a requestor 0 transaction before arbitration continues. This is only valid if there is a non-zero value for the Request Repeat 0 field (R0, bits [51:48]). This may be overridden by either COV, OV1, or OV0 (bits [23,21,20]). It is also ignored if PRE2 (bit 10) is cleared.
31:24	RSVD (RO)	<b>Reserved (Read Only).</b> Reserved for future use.
23	COV	<b>CPU Override.</b> Enables the CPU to override the repeat-count and grant-hold for other requestors. When COV is set and the CPU is requesting access to PCI, repeat-count and grant-hold mechanisms for other masters are temporarily disabled. This bit does not change the round robin arbitration cycle, it only overrides repeat-count and grant-hold for other requestors.
22	OV2	<b>Override 2.</b> Enables requester2 to override the repeat-count and grant-hold for other requestors. When OV2 is set and REQ2# is asserted, repeat-count and grant-hold mechanisms for other masters are temporarily disabled. This bit does not change the round robin arbitration cycle, it only overrides repeat-count and grant-hold for other requestors.
21	OV1	<b>Override 1.</b> Enables requester1 to override the repeat-count and grant-hold for other requestors. When OV1 is set and REQ1# is asserted, repeat-count and grant-hold mechanisms for other masters are temporarily disabled. This bit does not change the round robin arbitration cycle, it only overrides repeat-count and grant-hold for other requestors.

## GLPCI\_ARB Bit Definitions (Continued)

Bit	Name	Description
20	OV0	<b>Override 0.</b> Enables requester0 to override the repeat-count and grant-hold for other requestors. When OV0 is set and REQ0# is asserted, repeat-count and grant-hold mechanisms for other masters are temporarily disabled. This bit does not change the round robin arbitration cycle, it only overrides repeat-count and grant-hold for other requestors.
19	RSVD (RO)	<b>Reserved (Read Only).</b> Reserved for future use.
18	MSK2	<b>Request Mask 2.</b> Disables REQ2# when set to 1. Resets to 0.
17	MSK1	<b>Request Mask 1.</b> Disables REQ1# when set to 1. Resets to 0.
16	MSK0	<b>Request Mask 0.</b> Disables REQ0# when set to 1. Resets to 0.
15:12	RSVD (RO)	<b>Reserved (Read Only).</b> Reserved for future use.
11	CPRE	<b>CPU Preemption Enable.</b> When set to 1, the CPU's PCI grant may be de-asserted before the CPU's request is de-asserted. If this bit is cleared, the arbiter ignores CH and CR, bits [47:44] and [63:60].
10	PRE2	<b>Preemption Enable 2.</b> When set to 1, GNT2# may be de-asserted before REQ2# is de-asserted. If this bit is cleared, the arbiter ignores R2 and H2, bits [59:56] and [43:40].
9	PRE1	<b>Preemption Enable 1.</b> When set to 1, GNT1# may be de-asserted before REQ1# is de-asserted. If this bit is cleared, the arbiter ignores the R1 and H1, bits [55:52] and [39:36].
8	PRE0	<b>Preemption Enable 0.</b> When set to 1, GNT0# may be de-asserted before REQ0# is de-asserted. If this bit is cleared, the arbiter ignores R0 and H0, bits [51:48] and [35:32].
7	BM1 (RO)	<b>Broken Master 1 (Read Only).</b> Indicates when a broken master is attached to REQ1#. This bit is set when the arbiter detects that the PCI bus master attached to REQ1# has not asserted FRAME# within 16 PCI clock edges after being granted the PCI bus. This bit is cleared by setting BMD (bit 1) to 1.
6	BM0 (RO)	<b>Broken Master 0 (Read Only).</b> Indicates when a broken master is attached to REQ0#. This bit is set when the arbiter detects that the PCI bus master attached to REQ[0]# has not asserted FRAME# within 16 PCI clock edges after being granted the PCI bus. This bit is cleared by setting the BMD (bit 1) to 1.
5:2	RSVD (RO)	<b>Reserved (Read Only).</b> Reserved for future use.
1	BMD	<b>Broken Master Timer Disable.</b> Controls the operation of the broken master detector in the PCI arbiter. When set to 1, the arbiter does not recognize a broken master condition on the PCI bus. When cleared to 0, the arbiter detects a broken master condition when a granted PCI bus master takes 16 or more clock cycles before asserting FRAME#. The broken master is NOT allowed to gain access to the PCI bus. Software may restore any broken master's permission to use the PCI bus by clearing this bit, and optionally, setting it again.
0	PARK	<b>Parking Policy.</b> When cleared to 0, the arbiter always parks the PCI bus on the AMD Geode™ LX processor. When set to 1, the arbiter parks the PCI bus on the last granted bus master. If this bit is set, the clock for the PCI-fast clock domain should not be gated.

**6.16.2.3 GLPCI VPH / PCI Configuration Cycle Control (GLPCI\_PBUS)**

MSR Address 50002012h  
 Type R/W  
 Reset Value 00FF0000\_00000000h

The PBUS model specific register is used to control the way that the GLPCI module generates (or does not generate) PCI configuration cycles onto the PCI bus. SEC (bits [39:32]) should be configured with the PCI bus number for the locally attached PCI bus. SUB (bits [55:48]) should be configured with the PCI bus number for the highest numbered PCI bus that is accessible via the PCI interface. DEV (bits [31:0]) should be configured to indicate which device numbers will NOT generate PCI configuration cycles on the PCI bus.

**GLPCI\_PBUS Register Map**

63	62	61	60	59	58	57	56	55	54	53	52	51	50	49	48	47	46	45	44	43	42	41	40	39	38	37	36	35	34	33	32
RSVD								SUB								RSVD								SEC							
31	30	29	28	27	26	25	24	23	22	21	20	19	18	17	16	15	14	13	12	11	10	9	8	7	6	5	4	3	2	1	0
DEV																															

**GLPCI\_PBUS Bit Descriptions**

Bit	Name	Description
63:56	RSVD (RO)	<b>Reserved (Read Only).</b> Reserved for future use.
55:48	SUB	<b>Subordinate Bus Number.</b> Specifies the subordinate PCI bus number for all PCI buses reachable via the PCI interface.
47:40	RSVD (RO)	<b>Reserved (Read Only).</b> Reserved for future use.
39:32	SEC	<b>Secondary Bus Number.</b> Specifies the secondary PCI bus number for the PCI interface.
31:0	DEV	<b>Device Bitmap.</b> Specifies the virtualized PCI devices. Each bit position corresponds to a device number. A 0 instructs the GLPCI to allow PCI configuration cycles for the device to be generated on the PCI bus. A 1 tells the GLPCI to virtualize the device by generating an SSMI instead of a PCI configuration cycle.

**6.16.2.4 GLPCI Debug Packet Configuration (GLPCI\_DEBUG)**

MSR Address 50002013h  
 Type R/W  
 Reset Value 00000000\_00000000h

Control relay of debug packets to PCI. The functionality that this register controls has been removed from the GLIU. Therefore this register is obsolete.

**6.16.2.5 GLPCI Fixed Region Enables (GLPCI\_REN)**

MSR Address 50002014h  
 Type R/W  
 Reset Value 00000000\_00000000h

**GLPCI\_REN Register Map**

63	62	61	60	59	58	57	56	55	54	53	52	51	50	49	48	47	46	45	44	43	42	41	40	39	38	37	36	35	34	33	32
Spare																															
31	30	29	28	27	26	25	24	23	22	21	20	19	18	17	16	15	14	13	12	11	10	9	8	7	6	5	4	3	2	1	0
RSVD								E0	E8	E4	F0	EC	E8	E4	E0	DC	D8	D4	D0	CC	C8	C4	C0	BC	B8	B4	B0	AC	A8	A4	A0



**GLPCI\_REN Bit Descriptions**

Bit	Name	Description
63:32	Spare	<b>Spare Bits.</b> Extra bits available for future use. These bits may be set and cleared, but do not control anything.
31:24	RSVD (RO)	<b>Reserved (Read Only).</b> Reserved for future use
23	FC	<b>FC Enable.</b> Enables memory access to FC000 through FFFFF from PCI.
22	F8	<b>F8 Enable.</b> Enables memory access to F8000 through FBFFF from PCI.
21	F4	<b>F4 Enable.</b> Enables memory access to F4000 through F7FFF from PCI.
20	F0	<b>F0 Enable.</b> Enables memory access to F0000 through F3FFF from PCI.
19	EC	<b>EC Enable.</b> Enables memory access to EC000 through EFFFF from PCI.
18	E8	<b>E8 Enable.</b> Enables memory access to E8000 through EBFFF from PCI.
17	E4	<b>E4 Enable.</b> Enables memory access to E4000 through E7FFF from PCI.
16	E0	<b>E0 Enable.</b> Enables memory access to E0000 through E3FFF from PCI.
15	DC	<b>DC Enable.</b> Enables memory access to DC000 through DFFFF from PCI.
14	D8	<b>D8 Enable.</b> Enables memory access to D8000 through DBFFF from PCI.
13	D4	<b>D4 Enable.</b> Enables memory access to D4000 through D7FFF from PCI.
12	D0	<b>D0 Enable.</b> Enables memory access to D0000 through D3FFF from PCI.
11	CC	<b>CC Enable.</b> Enables memory access to CC000 through CFFFF from PCI.
10	C8	<b>C8 Enable.</b> Enables memory access to C8000 through CBFFF from PCI.
9	C4	<b>C4 Enable.</b> Enables memory access to C4000 through C7FFF from PCI.
8	C0	<b>C0 Enable.</b> Enables memory access to C0000 through C3FFF from PCI.
7	BC	<b>BC Enable.</b> Enables memory access to BC000 through BFFFF from PCI.
6	B8	<b>B8 Enable.</b> Enables memory access to B8000 through BBFFF from PCI.
5	B4	<b>B4 Enable.</b> Enables memory access to B4000 through B7FFF from PCI.
4	B0	<b>B0 Enable.</b> Enables memory access to B0000 through B3FFF from PCI.
3	AC	<b>AC Enable.</b> Enables memory access to AC000 through AFFFF from PCI.
2	A8	<b>A8 Enable.</b> Enables memory access to A8000 through ABFFF from PCI.
1	A4	<b>A4 Enable.</b> Enables memory access to A4000 through A7FFF from PCI.
0	A0	<b>A0 Enable.</b> Enables memory access to A0000 through A3FFF from PCI.

**6.16.2.6 GLPCI Fixed Region Configuration A0-BF (GLPCI\_A0)**

MSR Address 50002015h  
 Type R/W  
 Reset Value 00000000\_00000000h

**GLPCI\_A0 Register Map**

63	62	61	60	59	58	57	56	55	54	53	52	51	50	49	48	47	46	45	44	43	42	41	40	39	38	37	36	35	34	33	32
BC								B8								B4								B0							
31	30	29	28	27	26	25	24	23	22	21	20	19	18	17	16	15	14	13	12	11	10	9	8	7	6	5	4	3	2	1	0
AC								A8								A4								A0							

**GLPCI\_A0 Bit Descriptions**

Bit	Name	Description (Note 1)
63:56	BC	<b>BC Properties.</b> Region properties for BC000 through BFFFF.
55:48	B8	<b>B8 Properties.</b> Region properties for B8000 through BBFFF.
47:40	B4	<b>B4 Properties.</b> Region Properties for B4000 through B7FFF.
39:32	B0	<b>B0 Properties.</b> Region properties for B0000 through B3FFF.
31:24	AC	<b>AC Properties.</b> Region properties for AC000 through AFFFF.
23:16	A8	<b>A8 Properties.</b> Region Properties for A8000 through ABFFF.
15:8	A4	<b>A4 Properties.</b> Region Properties for A4000 through A7FFF.
7:0	A0	<b>A0 Properties.</b> Region properties for A0000 through A3FFF.

Note 1. See Table 6-93 for region properties bit decodes.

**Table 6-93. Region Properties**

Bit	Name	Description
7:6	RSVD (RO)	<b>Reserved (Read Only).</b> Reserved for future use.
5	PF	<b>Prefetchable.</b> Reads to this region have no side-effects.
4	WC	<b>Write Combine.</b> Writes to this region may be combined.
3	RSVD (RO)	<b>Reserved (Read Only).</b> Reserved for future use.
2	WP	<b>Write Protect.</b> When set to 1, only read accesses are allowed. Write accesses are ignored (master abort).
1	DD	<b>Discard Data.</b> When set to 1, write access are accepted and discarded. Read accesses are ignored (master abort).
0	CD	<b>Cache Disable.</b> When set to 1, accesses are marked as non-coherent. When cleared to 0, accesses are marked as coherent.

**6.16.2.7 GLPCI Fixed Region Configuration C0-DF (GLPCI\_C0)**

MSR Address 50002016h  
 Type R/W  
 Reset Value 00000000\_00000000h

**GLPCI\_C0 Register Map**

63	62	61	60	59	58	57	56	55	54	53	52	51	50	49	48	47	46	45	44	43	42	41	40	39	38	37	36	35	34	33	32
DC								D8								D4								D0							
31	30	29	28	27	26	25	24	23	22	21	20	19	18	17	16	15	14	13	12	11	10	9	8	7	6	5	4	3	2	1	0
CC								C8								C4								C0							

**GLPCI\_C0 Bit Descriptions**

Bit	Name	Description (Note 1)
63:56	DC	<b>DC Properties.</b> Region properties for DC000 through DFFFF.
55:48	D8	<b>D8 Properties.</b> Region properties for D8000 through DBFFF.
47:40	D4	<b>D4 Properties.</b> Region Properties for D4000 through D7FFF.

## GLPCI\_C0 Bit Descriptions (Continued)

Bit	Name	Description (Note 1)
39:32	D0	<b>D0 Properties.</b> Region properties for D0000 through D3FFF.
31:24	CC	<b>CC Properties.</b> Region properties for CC000 through CFFFF.
23:16	C8	<b>C4 Properties.</b> Region Properties for C8000 through CBFFF.
15:8	C4	<b>C4 Properties.</b> Region Properties for C4000 through C3FFF.
7:0	C0	<b>C0 Properties.</b> Region properties for C0000 through C3FFF.

Note 1. See Table 6-93 on page 586 for region properties bit decodes.

## 6.16.2.8 GLPCI Fixed Region Configuration E0-FF (GLPCI\_E0)

MSR Address 50002017h  
 Type R/W  
 Reset Value 00000000\_00000000h

## GLPCI\_E0 Register Map

63	62	61	60	59	58	57	56	55	54	53	52	51	50	49	48	47	46	45	44	43	42	41	40	39	38	37	36	35	34	33	32
FC								F8								F4								F0							
31	30	29	28	27	26	25	24	23	22	21	20	19	18	17	16	15	14	13	12	11	10	9	8	7	6	5	4	3	2	1	0
EC								E8								E4								E0							

## GLPCI\_E0 Bit Descriptions

Bit	Name	Description (Note 1)
63:56	FC	<b>FC Properties.</b> Region properties for FC000 through FFFFF.
55:48	F8	<b>F8 Properties.</b> Region properties for F8000 through FBFFF.
47:40	F4	<b>F4 Properties.</b> Region Properties for F4000 through F7FFF.
39:32	F0	<b>F0 Properties.</b> Region properties for F0000 through F3FFF.
31:24	EC	<b>EC Properties.</b> Region properties for EC000 through EFFFF.
23:16	E8	<b>E4 Properties.</b> Region Properties for E8000 through EBFFF.
15:8	E4	<b>E4 Properties.</b> Region Properties for E4000 through E3FFF.
7:0	E0	<b>E0 Properties.</b> Region properties for E0000 through E3FFF.

Note 1. See Table 6-93 on page 586 for region properties bit decodes.

**6.16.2.9 GLPCI Memory Region 0 Configuration (GLPCI\_R0)**

MSR Address 50002018h  
 Type R/W  
 Reset Value 00000000\_00000000h

**GLPCI\_R0 Register Map**

63	62	61	60	59	58	57	56	55	54	53	52	51	50	49	48	47	46	45	44	43	42	41	40	39	38	37	36	35	34	33	32
TOP														RSVD																	
31	30	29	28	27	26	25	24	23	22	21	20	19	18	17	16	15	14	13	12	11	10	9	8	7	6	5	4	3	2	1	0
BASE														RSVD		EN	RSVD		PF	WC	RSVD	WP	DD	CD							

**GLPCI\_R0 Bit Descriptions**

Bit	Name	Description
63:44	TOP	<b>Top of Region.</b> 4 KB granularity, inclusive.
43:32	RSVD (RO)	<b>Reserved (Read Only).</b> Reserved for future use.
31:12	BASE	<b>Base of Region.</b> 4 KB granularity, inclusive.
11:9	RSVD (RO)	<b>Reserved (Read Only).</b> Reserved for future use.
8	EN	<b>Region Enable.</b> Set to 1 to enable access to this region.
7:6	RSVD (RO)	<b>Reserved (Read Only).</b> Reserved for future use.
5	PF	<b>Prefetchable.</b> Reads to this region have no side-effects.
4	WC	<b>Write Combine.</b> Writes to this region may be combined.
3	RSVD (RO)	<b>Reserved (Read Only).</b> Reserved for future use.
2	WP	<b>Write Protect.</b> When set to 1, only read accesses are allowed. Write accesses are ignored (master abort).
1	DD	<b>Discard Data.</b> When set to 1, write access are accepted and discarded. Read accesses are ignored (master abort).
0	CD	<b>Cache Disable.</b> When set to 1, accesses are marked as non-coherent. When cleared to 0 accesses are marked as coherent.

**6.16.2.10 GLPCI Memory Region 1 Configuration (GLPCI\_R1)**

MSR Address 50002019h  
 Type R/W  
 Reset Value 00000000\_00000000h

**GLPCI\_R1 Register Map**

63	62	61	60	59	58	57	56	55	54	53	52	51	50	49	48	47	46	45	44	43	42	41	40	39	38	37	36	35	34	33	32
TOP														RSVD																	
31	30	29	28	27	26	25	24	23	22	21	20	19	18	17	16	15	14	13	12	11	10	9	8	7	6	5	4	3	2	1	0
BASE														RSVD		EN	RSVD		PF	WC	RSVD	WP	DD	CD							

**GLPCI\_R1 Bit Descriptions**

Bit	Name	Description
63:44	TOP	<b>Top of Region.</b> 4 KB granularity, inclusive.
43:32	RSVD (RO)	<b>Reserved (Read Only).</b> Reserved for future use.
31:12	BASE	<b>Base of Region.</b> 4 KB granularity, inclusive.
11:9	RSVD (RO)	<b>Reserved (Read Only).</b> Reserved for future use.
8	EN	<b>Region Enable.</b> Set to 1 to enable access to this region.
7:6	RSVD (RO)	<b>Reserved (Read Only).</b> Reserved for future use.
5	PF	<b>Prefetchable.</b> Reads to this region have no side-effects.
4	WC	<b>Write Combine.</b> Writes to this region may be combined.
3	RSVD (RO)	<b>Reserved (Read Only).</b> Reserved for future use.
2	WP	<b>Write Protect.</b> When set to 1, only read accesses are allowed. Write accesses are ignored (master abort).
1	DD	<b>Discard Data.</b> When set to 1, write access are accepted and discarded. Read accesses are ignored (master abort).
0	CD	<b>Cache Disable.</b> When set to 1, accesses are marked as non-coherent. When cleared to 0, accesses are marked as coherent.

**6.16.2.11 GLPCI Memory Region 2 Configuration (GLPCI\_R2)**

MSR Address 5000201Ah  
 Type R/W  
 Reset Value 00000000\_00000000h

**GLPCI\_R2 Register Map**

63	62	61	60	59	58	57	56	55	54	53	52	51	50	49	48	47	46	45	44	43	42	41	40	39	38	37	36	35	34	33	32
TOP														RSVD																	
31	30	29	28	27	26	25	24	23	22	21	20	19	18	17	16	15	14	13	12	11	10	9	8	7	6	5	4	3	2	1	0
BASE														RSVD		EN	RSVD		PF	WC	RSVD	WP	DD	CD							

**GLPCI\_R2 Bit Descriptions**

Bit	Name	Description
63:44	TOP	<b>Top of Region.</b> 4 KB granularity, inclusive.
43:32	RSVD (RO)	<b>Reserved (Read Only).</b> Reserved for future use.
31:12	BASE	<b>Base of Region.</b> 4 KB granularity, inclusive.
11:9	RSVD (RO)	<b>Reserved (Read Only).</b> Reserved for future use.
8	EN	<b>Region Enable.</b> Set to 1 to enable access to this region.
7:6	RSVD (RO)	<b>Reserved (Read Only).</b> Reserved for future use.
5	PF	<b>Prefetchable.</b> Reads to this region have no side-effects.
4	WC	<b>Write Combine.</b> Writes to this region may be combined.
3	RSVD (RO)	<b>Reserved (Read Only).</b> Reserved for future use.
2	WP	<b>Write Protect.</b> When set to 1, only read accesses are allowed. Write accesses are ignored (master abort).
1	DD	<b>Discard Data.</b> When set to 1, write access are accepted and discarded. Read accesses are ignored (master abort).
0	CD	<b>Cache Disable.</b> When set to 1, accesses are marked as non-coherent. When cleared to 0, accesses are marked as coherent.

**6.16.2.12 GLPCI Memory Region 3 Configuration (GLPCI\_R3)**

MSR Address 5000201Bh  
 Type R/W  
 Reset Value 00000000\_00000000h

**GLPCI\_R3 Register Map**

63	62	61	60	59	58	57	56	55	54	53	52	51	50	49	48	47	46	45	44	43	42	41	40	39	38	37	36	35	34	33	32
TOP														RSVD																	
31	30	29	28	27	26	25	24	23	22	21	20	19	18	17	16	15	14	13	12	11	10	9	8	7	6	5	4	3	2	1	0
BASE														RSVD		EN	RSVD		PF	WC	RSVD	WP	DD	CD							

**GLPCI\_R3 Bit Descriptions**

Bit	Name	Description
63:44	TOP	<b>Top of Region.</b> 4 KB granularity, inclusive.
43:32	RSVD (RO)	<b>Reserved (Read Only).</b> Reserved for future use.
31:12	BASE	<b>Base of Region.</b> 4 KB granularity, inclusive.
11:9	RSVD (RO)	<b>Reserved (Read Only).</b> Reserved for future use.
8	EN	<b>Region Enable.</b> Set to 1 to enable access to this region.
7:6	RSVD (RO)	<b>Reserved (Read Only).</b> Reserved for future use.
5	PF	<b>Prefetchable.</b> Reads to this region have no side-effects.
4	WC	<b>Write Combine.</b> Writes to this region may be combined.
3	RSVD (RO)	<b>Reserved (Read Only).</b> Reserved for future use.
2	WP	<b>Write Protect.</b> When set to 1, only read accesses are allowed. Write accesses are ignored (master abort).
1	DD	<b>Discard Data.</b> When set to 1, write access are accepted and discarded. Read accesses are ignored (master abort).
0	CD	<b>Cache Disable.</b> When set to 1, accesses are marked as non-coherent. When cleared to 0, accesses are marked as coherent.

**6.16.2.13 GLPCI Memory Region 4 Configuration (GLPCI\_R4)**

MSR Address 5000201Ch  
 Type R/W  
 Reset Value 00000000\_00000000h

**GLPCI\_R4 Register Map**

63	62	61	60	59	58	57	56	55	54	53	52	51	50	49	48	47	46	45	44	43	42	41	40	39	38	37	36	35	34	33	32
TOP														RSVD																	
31	30	29	28	27	26	25	24	23	22	21	20	19	18	17	16	15	14	13	12	11	10	9	8	7	6	5	4	3	2	1	0
BASE														RSVD		EN	RSVD		PF	WC	RSVD	WP	DD	CD							

**GLPCI\_R4 Bit Descriptions**

Bit	Name	Description
63:44	TOP	<b>Top of Region.</b> 4 KB granularity, inclusive.
43:32	RSVD (RO)	<b>Reserved (Read Only).</b> Reserved for future use.
31:12	BASE	<b>Base of Region.</b> 4 KB granularity, inclusive.
11:9	RSVD (RO)	<b>Reserved (Read Only).</b> Reserved for future use.
8	EN	<b>Region Enable.</b> Set to 1 to enable access to this region.
7:6	RSVD (RO)	<b>Reserved (Read Only).</b> Reserved for future use.
5	PF	<b>Prefetchable.</b> Reads to this region have no side-effects.
4	WC	<b>Write Combine.</b> Writes to this region may be combined.
3	RSVD (RO)	<b>Reserved (Read Only).</b> Reserved for future use.
2	WP	<b>Write Protect.</b> When set to 1, only read accesses are allowed. Write accesses are ignored (master abort).
1	DD	<b>Discard Data.</b> When set to 1, write access are accepted and discarded. Read accesses are ignored (master abort).
0	CD	<b>Cache Disable.</b> When set to 1, accesses are marked as non-coherent. When cleared to 0, accesses are marked as coherent.



**6.16.2.14 GLPCI Memory Region 5 Configuration (GLPCI\_R5)**

MSR Address 5000201Dh  
 Type R/W  
 Reset Value 00000000\_00000000h

**GLPCI\_R5 Register Map**

63	62	61	60	59	58	57	56	55	54	53	52	51	50	49	48	47	46	45	44	43	42	41	40	39	38	37	36	35	34	33	32
TOP														RSVD																	
31	30	29	28	27	26	25	24	23	22	21	20	19	18	17	16	15	14	13	12	11	10	9	8	7	6	5	4	3	2	1	0
BASE														RSVD		EN	RSVD		PF	WC	RSVD	WP	DD	CD							

**GLPCI\_R5 Bit Descriptions**

Bit	Name	Description
63:44	TOP	<b>Top of Region.</b> 4 KB granularity, inclusive.
43:32	RSVD (RO)	<b>Reserved (Read Only).</b> Reserved for future use.
31:12	BASE	<b>Base of Region.</b> 4 KB granularity, inclusive.
11:9	RSVD (RO)	<b>Reserved (Read Only).</b> Reserved for future use.
8	EN	<b>Region Enable.</b> Set to 1 to enable access to this region.
7:6	RSVD (RO)	<b>Reserved (Read Only).</b> Reserved for future use.
5	PF	<b>Prefetchable.</b> Reads to this region have no side-effects.
4	WC	<b>Write Combine.</b> Writes to this region may be combined.
3	RSVD (RO)	<b>Reserved (Read Only).</b> Reserved for future use.
2	WP	<b>Write Protect.</b> When set to 1, only read accesses are allowed. Write accesses are ignored (master abort).
1	DD	<b>Discard Data.</b> When set to 1, write access are accepted and discarded. Read accesses are ignored (master abort).
0	CD	<b>Cache Disable.</b> When set to 1, accesses are marked as non-coherent. When cleared to 0, accesses are marked as coherent.

**6.16.2.15 GLPCI External MSR Access Configuration (GLPCI\_EXT\_MSR)**

MSR Address 5000201Eh  
 Type R/W  
 Reset Value 00000000\_00000000h

**GLPCI\_EXT\_MSR Register Map**

63	62	61	60	59	58	57	56	55	54	53	52	51	50	49	48	47	46	45	44	43	42	41	40	39	38	37	36	35	34	33	32
RSVD								FUNC-7				DEVICE-7				FUNC-6			DEVICE-6				FUNC-5			DEVICE-5					
31	30	29	28	27	26	25	24	23	22	21	20	19	18	17	16	15	14	13	12	11	10	9	8	7	6	5	4	3	2	1	0
FUNC-4				DEVICE-4				FUNC-3				DEVICE-3				FUNC-2			DEVICE-2				FUNC-1			DEVICE-1					

**GLPCI\_EXT\_MSR Bit Descriptions**

Bit	Name	Description
63:56	RSVD (RO)	<b>Reserved (Read Only).</b> Reserved for future use.
55:53	FUNC-7	<b>Function Number 7.</b> PCI function number to use for MSR accesses addressed to Port 7.
52:48	DEVICE-7	<b>Device Number 7.</b> PCI device number to use for MSR accesses addressed to Port 7.
47:45	FUNC-6	<b>Function Number 6.</b> PCI function number to use for MSR accesses addressed to Port 6.
44:40	DEVICE-6	<b>Device Number 6.</b> PCI device number to use for MSR accesses addressed to Port 6.
39:37	FUNC-5	<b>Function Number 5.</b> PCI function number to use for MSR accesses addressed to Port 5.
36:32	DEVICE-5	<b>Device Number 5.</b> PCI device number to use for MSR accesses addressed to Port 5.
31:29	FUNC-4	<b>Function Number 4.</b> PCI function number to use for MSR accesses addressed to Port 4.
28:24	DEVICE-4	<b>Device Number 4.</b> PCI device number to use for MSR accesses addressed to Port 4.
23:21	FUNC-3	<b>Function Number 3.</b> PCI function number to use for MSR accesses addressed to Port 3.
20:16	DEVICE-3	<b>Device Number 3.</b> PCI device number to use for MSR accesses addressed to Port 3.
15:13	FUNC-2	<b>Function Number 2.</b> PCI function number to use for MSR accesses addressed to Port 2.
12:8	DEVICE-2	<b>Device Number 2.</b> PCI device number to use for MSR accesses addressed to Port 2.
7:5	FUNC-1	<b>Function Number 1.</b> PCI function number to use for MSR accesses addressed to Port 1.
4:0	DEVICE-1	<b>Device Number 1.</b> PCI device number to use for MSR accesses addressed to Port 1.

**Note:** MSR accesses addressed to Port 0 are handled directly by the GLPCI module.

**6.16.2.16 GLPCI Spare**

MSR Address 5000201Fh  
 Type R/W  
 Reset Value 00000000\_00000003h

**GLPCI Spare**

63	62	61	60	59	58	57	56	55	54	53	52	51	50	49	48	47	46	45	44	43	42	41	40	39	38	37	36	35	34	33	32
Spare																															
31	30	29	28	27	26	25	24	23	22	21	20	19	18	17	16	15	14	13	12	11	10	9	8	7	6	5	4	3	2	1	0
Spare																					RSVD		AILTO	PPD	PPC	MPC	MME	NSE	SUPO		

**GLPCI Spare Bit Descriptions**

Bit	Name	Description
63:10	Spare	<b>Spare Bits.</b> Extra bits available for future use. These bits may be set and cleared, but do not control anything.
9:7	RSVD	<b>Reserved.</b> Write as read.
6	AILTO	<b>Alternate Initial Latency Timeout.</b> Enables alternate initial latency timeout values to be configured via ILTO (MSR 50002010h[41:40]).
5	PPD	<b>Post PIO Data.</b> Enables posting of I/O writes to addresses: 170h and 1F0h.
4	PPC	<b>Post PIO Control.</b> Enables posting of I/O writes to addresses: 171h, 172h, 173h, 174h, 175h, 176h, 177h, 1F1h, 1F2h, 1F3h, 1F4h, 1F5h, 1F6h and 1F7h.
3	MPC	<b>Maximum Posted Count.</b> Controls the maximum number of PIO I/O writes that may be posted in the GLPCI. When cleared, one I/O write may be posted. When set, two I/O writes may be posted.
2	MME	<b>Mask External MSR Exceptions.</b> Set to 1 to force the GLIU synchronous exception flag to be cleared for all external MSR transactions.
1	NSE	<b>No Synchronous Exceptions.</b> Controls when out-bound read data is written into the OBRD FIFO. When this bit is cleared, the GLPCI pipelines the writing of all out-bound read data into the FIFO. This allows PCI transaction status to be sampled and included synchronously with the read data. When this bit is cleared, the GLPCI only pipelines read data for external MSR accesses and I/O read of the configuration data port (0CFCh).
0	SUPO	<b>Strict Up-Stream Ordering.</b> Controls how out-bound reads get sorted with in-bound writes. When this bit is set the ordering rules are strictly applied; meaning that all GLIU write responses associated with a in-bound PCI write transaction must complete before data from a subsequent out-bound PCI read may be placed onto the GLIU. When this bit is cleared the out-bound read data may be placed onto the GLIU after the in-bound write data has been placed onto the GLIU.

**6.16.2.17 GLPCI General Purpose I/O (GLPCI\_GPIO)**

MSR Address 50002020h  
 Type R/W  
 Reset Value 00000000\_00000000h

**GLPCI\_GPIO Register Map**

63	62	61	60	59	58	57	56	55	54	53	52	51	50	49	48	47	46	45	44	43	42	41	40	39	38	37	36	35	34	33	32
MSW	RSVD															SAMPDIV															
	31	30	29	28	27	26	25	24	23	22	21	20	19	18	17	16	15	14	13	12	11	10	9	8	7	6	5	4	3	2	1
RSVD													OE2	OE1	OE0	RSVD						OUT2	OUT1	OUT0	RSVD				IN2	IN1	IN0

**GLPCI\_GPIO Register Bit Descriptions**

Bit	Name	Description
63	MSW	<b>Most Significant Word Enable.</b> Must be set on writes to alter SAMPDIV (bits [47:32]). When cleared, the SAMPDIV field will not be updated. When set, the SAMPDIV field will be written.
62:48	RSVD (RO)	<b>Reserved (Read Only).</b> Reserved for future use.
47:32	SAMPDIV	<b>Sample Divider.</b> Controls the frequency of sampling input data fed into each filter. With a value of zero, each input is sampled on every PCI clock edge. With a value of 1, each input is sampled every other clock edge. With a value of 2, it is sampled every third clock edge, and so on.
31:19	RSVD (RO)	<b>Reserved (Read Only).</b> Reserved for future use.
18	OE2	<b>Output Enable 2.</b> Output enable for GNT2# pin.
17	OE1	<b>Output Enable 1.</b> Output enable for REQ1# pin.
16	OE0	<b>Output Enable 0.</b> Output enable for GNT1# pin.
15:11	RSVD (RO)	<b>Reserved (Read Only).</b> Reserved for future use.
10	OUT2	<b>Output 2.</b> Output for GNT2# pin.
9	OUT1	<b>Output 1.</b> Output for REQ1# pin.
8	OUT0	<b>Output 0.</b> Output for GNT1# pin.
7:3	RSVD (RO)	<b>Reserved (Read Only).</b> Reserved for future use.
2	IN2 (RO)	<b>Input 2 (Read Only).</b> Filtered input from GNT2# pin.
1	IN1 (RO)	<b>Input 1 (Read Only).</b> Filtered input from REQ1# pin.
0	IN0 (RO)	<b>Input 0 (Read Only).</b> Filtered input from GNT1# pin.

# Electrical Specifications

# 7

This section provides information on electrical connections, absolute maximum ratings, operating conditions, and DC/AC characteristics for the AMD Geode™ LX processor. All voltage values in the electrical specifications are with respect to  $V_{SS}$  unless otherwise noted.

## 7.1 Electrical Connections

### 7.1.1 PWR/GND Connections and Decoupling

Testing and operating the AMD Geode LX processor requires the use of standard high frequency techniques to reduce parasitic effects. When using this device, the effects can be minimized by filtering the DC power leads with low-inductance decoupling capacitors, using low-impedance wiring, and by connecting all  $V_{CORE}$ ,  $V_{IO}$ ,  $V_{MEM}$ , and analog balls to the appropriate voltage levels.

### 7.1.2 NC-Designated Balls

Balls designated as NC (No Connection) should be left disconnected. Connecting an NC ball to a pull-up/-down resistor, or an active signal could cause unexpected results and possible circuit malfunctions.

### 7.1.3 Unused Inputs

All inputs not used by the system designer should be kept at either ground or  $V_{IO}$ . To prevent possible spurious operation. For active-high inputs to ground through a 20-k $\Omega$  ( $\pm 10\%$ ) pull-down resistor and active-low inputs to  $V_{IO}$  through a 20-k $\Omega$  ( $\pm 10\%$ ) pull-up resistor can be used if desired.

## 7.2 Absolute Maximum Ratings

Table 7-1 lists absolute maximum ratings for the AMD Geode LX processor. Stresses beyond the listed ratings may cause permanent damage to the device. Exposure to conditions beyond these limits may (1) reduce device reliability and (2) result in premature failure even when there is no immediately apparent sign of failure. Prolonged exposure to conditions at or near the absolute maximum ratings may also result in reduced useful life and reliability. These are stress ratings only and do not imply that operation under any conditions other than those listed in Table 7-2 "Operating Conditions" on page 598 is possible.

**Table 7-1. Absolute Maximum Ratings**

Symbol	Parameter	Min	Max	Unit	Comments
$T_{STORAGE}$	Storage Temperature	-65	150	°C	No Bias
$V_{CORE}$	Core Supply Voltage		1.5	V	
$V_{IO}$	I/O Supply Voltage	3.0	3.6	V	Also applies to $V_{CA}$ , $V_{MA}$ , $V_{VA}$ , and $V_{DAC}$
$V_{MEM}$	Memory Voltage		3.6	V	
$V_{MAX}$	Voltage On Any Pin	-0.5	3.8	V	Except HSYNC, VSYNC
	Voltage on HSYNC, VSYNC	-0.5	5.5	V	
	ESD - Human Body Model		2000	V	
	ESD - Machine Model		200	V	

## 7.3 Operating Conditions

Table 7-2 lists the operating conditions for the AMD Geode LX processor.

**Table 7-2. Operating Conditions**

Symbol	Parameter (Note 1)	Min	Typ	Max	Unit	Comments
TC	Operating Case Temperature LX 900@1.5W	0		80	°C	
	Operating Case Temperature LX 800@0.9W	0		85	°C	See Section A.1 "Order Information" for applicable OPN.
		-40		85	°C	
	Operating Case Temperature LX 700@0.8W LX 600@0.7W	0		85	°C	
VCORE	Core Supply Voltage LX 900@1.5W	1.36	1.40	1.44	V	Filtered version of this supply also supplies PLL power. Note 2
	Core Supply Voltage LX 800@0.9W	1.21	1.25	1.29	V	
	Core Supply Voltage LX 700@0.8W LX 600@0.7W	1.16	1.20	1.24	V	
VIO	I/O Supply Voltage	3.14	3.3	3.46	V	Filtered version of this supply also supplies DAC power. Note 3
VVA	Video PLL Supply Voltage	3.14	3.30	3.46	V	Filtered version of VIO. Note 3
VMA	Memory PLL Supply Voltage	3.14	3.30	3.46	V	
VCA	CPU PLL Supply Voltage	3.14	3.30	3.46	V	
VDAC	DAC PLL Supply Voltage	3.14	3.30	3.46	V	
VMEM	DDR (2.6V SSTL) LX 900@1.5W, LX 800@0.9W	2.47	2.60	2.73	V	Note 3
	DDR (2.5V SSTL) LX 700@0.8W	2.38	2.50	2.63	V	
	DDR2 (1.9V) LX 900@1.5W, LX 800@0.9W LX 700@0.8W	1.81	1.90	2.00	V	
	DDR2 (1.8V) LX 600@0.7W	1.71	1.80	1.89	V	
MVREF	DDR LX 900@1.5W, LX 800@0.9W	1.23	1.30	1.37	V	Note 3, Note 4
	DDR LX 700@0.8W	1.19	1.25	1.31	V	
	DDR2 LX 900@1.5W, LX 800@0.9W LX 700@0.8W	0.90	0.95	1.0		
	DDR2 (1.8V) LX 600@0.7W	0.86	0.90	0.95		

Note 1. The AMD Geode LX 900@1.5W processor operates at 600 MHz, the AMD Geode LX 800@0.9W processor operates at 500 MHz, the AMD Geode LX 700@0.8W processor operates at 433 MHz and the AMD Geode LX 600@.07W processor operates at 366 MHz. Model numbers reflect performance as described here: <http://www.amd.com/connectivitysolutions/geodelxbenchmark>.

Note 2. This parameter is calculated as nominal  $\pm 3\%$ .

Note 3. This parameter is calculated as nominal  $\pm 5\%$ .

Note 4.  $MVREF = 1/2 V_{MEM}$ .

## 7.4 DC Current

DC current is not a simple measurement. Three of the AMD Geode LX processor's power states (ON, Active Idle, and Sleep) were selected for measurement. For the ON power state measured, two functional characteristics (Typical Average and Absolute Maximum) are used to determine how much current the processor requires.

### 7.4.1 Power State Parameter Definitions

The DC current tables in this section list Core and I/O current for three of the power states.

- **On (S0/C0):** All internal and external clocks with respect to the AMD Geode LX processor are running and all functional blocks (CPU Core, Memory Controller, Display Controller, etc.) are actively generating cycles. This is equivalent to the ACPI specification's "S0/C0" state.
- **Active Idle (S0/C1):** The CPU Core has been halted and all other functional blocks (including the Display Controller for refreshing the display) are actively generating cycles. This state is entered when a HLT instruction is executed by the CPU Core. From a user's perspective, this state is indistinguishable from the On state and is equivalent to the ACPI specification's "S0/C1" state.
- **Sleep (S1):** This is the lowest power state the AMD Geode LX processor can be in with voltage still applied to the device's core and I/O supply pins. This is equivalent to the ACPI specification's "S1" state.

All measurements were taken at 25°C ambient air.

### 7.4.2 Definition and Measurement Techniques of Current Parameters

The following two parameters describe the AMD Geode LX processor current while in the ON state:

#### Typical Average

Typical Average (Typ Avg) indicates the average current used by the AMD Geode LX processor while in the ON state, with no active power management. This measurement is comprised of two components: WinBench® 99 Business Graphics Test and Active Idle power measurements. WinBench 99 represents a maximum typical state as it simulates a knowledgeable worker's typical day compressed into the shortest period of time possible. Since it is not possible for someone to operate as fast as the benchmark, the resulting power from the benchmark is averaged with Active Idle in an 80/20 ratio, with 80% of the time being in the Windows® XP Idle state and 20% of the time running applications. This results in a Typical Average power result.

For each voltage, power is measured at one second intervals. The measurements are then averaged together to produce the final number. The CRT resolution is 1024x768x32 bpp, at 85 Hz refresh and the TFT resolution

is 1024x768 x16 bpp at 60 Hz refresh. This number is provided for reference only since it can vary depending on the usage model of the system.

#### Thermal Design Power

Absolute Maximum and Thermal Design Power (TDP) indicates the maximum average current used by the AMD Geode LX processor. This is measured with the voltages at maximum. An internally-developed AMD application called *Pathological Power Measurement Application* causes the AMD Geode LX processor to consume the maximum amount of power for the Core and I/O rails, while WinBench 99 Business Graphics Test causes the AMD Geode LX processor to consume maximum power on the memory rail. All tests were run at the maximum supported resolution of 1920x1440x32 bpp at 72 Hz refresh for the CRT and 1600x1200x16 bpp at 60 Hz refresh for TFT.

This test does not guarantee maximum current. There may be pathological applications that result in higher measured currents.

TDP is a function of all power contributors at maximum. Applications that do not use the CRT or TFT output will have a somewhat lower TDP. Operating the memory subsystem at a lower frequency will also lower TDP. Specific software applications may place lower compute demands on the CPU, which lowers the TDP as well.

If needed, it is up to the system designer to determine TDP for systems that operate with conditions that are different than those specified, however, the TDP specified is the maximum.

#### Active Idle

Active Idle power is measured at the Windows XP Idle state when the monitor is still turned on. During this state the "Bliss" background is used. The CRT resolution is 1024x768x32 bpp, at 85 Hz refresh and 1024x768 x16 bpp at 60 Hz refresh is used for TFT. This number is provided for reference only since it can vary depending on the background image and processes running on the system.

#### Sleep

The Sleep power state is achieved by forcing the system into a "S1" state as defined by the ACPI specification.

### 7.4.3 DC Current Measurements

Tables 7-3, 7-4, and 7-5 show the DC current measurements of the AMD Geode LX processor family. The processor supports CRT or TFT displays.

The CRT DACs require current; while the TFT interface, even though it has no DAC to power, also draws current while it is active. Therefore, the CRT DACs and the TFT interface currents are specified in separate tables.

The data bus on the DDR SDRAM has a low voltage swing when actively terminated (terminated topology). The terminated topology supports higher data transfer rates and is less constrained, but it consumes more power. Many designs should be able to operate reliably without active termination (unterminated topology). The design constraints are smaller memory subsystems and tight control on routing. See the application note, *AMD Geode™ LX Processor and CS5535/CS5536 Companion Device Layout Recommendations* (publication ID #32739), for more information.

When series termination resistors are used, as specified in the *AMD Geode™ LX Processor and CS5535/CS5536 Companion Device Layout Recommendations*, the actual power provided by the  $V_{MEMLX}$  supply is split between the processor and the series and parallel termination (see Figure 7-1). Therefore, it is impossible to specify the power used by the processor's memory subsystem with one hundred percent accuracy. A conservative estimate, is that 32.5% of the power is consumed by the processor and

67.5% by the termination resistors. See the *AMD Geode™ LX Processor Determining Memory Interface I/O Power Consumption* document (publication ID #40554) for the detailed analysis. This number is used for the results in DC Current tables (Tables 7-3, 7-4, and 7-5).

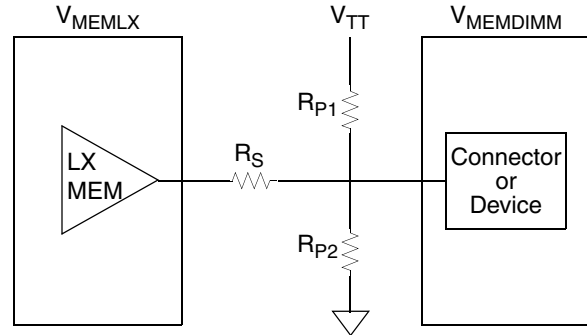


Figure 7-1.  $V_{MEMLX}$  Power Split

Table 7-3. AMD Geode LX 900@1.5W Processor DC Currents

LX 900@1.5W (600 MHz), No EEPROM, $V_{CORE} = 1.4V$ , $TDP_T = 5.3W$ , $TDP_U = 5.1W$ (Note 1)					
Symbol	Parameter	Typ Avg	Max	Unit	Comments
$I_{CC3ON}$ - CRT Display	Power State: On (S0/C0)	85	100	mA	
$I_{CC3ON}$ - TFT Display		37	45		
$I_{COREON}$		1420	3140		
$I_{MEMON}$ - Terminated		150	165		Note 2, Note 3
$I_{MEMON}$ - Unterminated		90	100		Note 3
$I_{MEMDDR2ON}$		80	95		
$I_{CC3IDLE}$ - CRT Display	Power State: Active Idle (S0/C1)	85		mA	
$I_{CC3IDLE}$ - TFT Display		37			
$I_{COREIDLE}$		1250			
$I_{MEMIDLE}$ - Terminated		150			Note 2, Note 3
$I_{MEMIDLE}$ - Unterminated		80			Note 3
$I_{CC3SLP}$ - CRT Display		Power State: Sleep (S1)	4		
$I_{CC3SLP}$ - TFT Display	4				
$I_{CORESLP}$	600				
$I_{MEMSLP}$ - Terminated	100			Note 2, Note 3	
$I_{MEMSLP}$ - Unterminated	35			Note 3	

Note 1. The AMD Geode LX 900@1.5W processor operates at 600 MHz. Model numbers reflect performance as described here: <http://www.amd.com/connectivitysolutions/geodelxbenchmark>.

T = Terminated and U = Unterminated.

Note 2. Calculations are based on a 32.5/67.5 split between  $V_{MEMLX}$  used by the AMD Geode LX processor and series termination resistors. See Section 7.4.3 on page 599 for more details.

Note 3.  $V_{MEM}$  is 2.6V for the LX 900@1.5W processor.



Table 7-4. AMD Geode LX 800@0.9W Processor DC Currents

LX 800@0.9W (500 MHz), No EEPROM, $V_{CORE} = 1.25V$ , $TDP_T = 3.8W$ , $TDP_U = 3.6W$ (Note 1)					
Symbol	Parameter	Typ Avg	Max	Unit	Comments
$I_{CC3ON}$ - CRT Display	Power State: On (S0/C0)	85	100	mA	
$I_{CC3ON}$ - TFT Display		37	45		
$I_{COREON}$		1010	2290		
$I_{MEMON}$ - Terminated		150	165		Note 2, Note 3
$I_{MEMON}$ - Unterminated		90	100		Note 3
$I_{MEMDDR2ON}$		80	95		
$I_{CC3IDLE}$ - CRT Display	Power State: Active Idle (S0/C1)	85		mA	
$I_{CC3IDLE}$ - TFT Display		37			
$I_{COREIDLE}$		885			
$I_{MEMIDLE}$ - Terminated		150			Note 2, Note 3
$I_{MEMIDLE}$ - Unterminated		80			Note 3
$I_{CC3SLP}$ - CRT Display		Power State: Sleep (S1)	4		
$I_{CC3SLP}$ - TFT Display	4				
$I_{CORESLP}$	225				
$I_{MEMSLP}$ - Terminated	100			Note 2, Note 3	
$I_{MEMSLP}$ - Unterminated	35			Note 3	

Note 1. The AMD Geode LX 800@0.9W processor operates at 500 MHz. Model numbers reflect performance as described here: <http://www.amd.com/connectivitysolutions/geodelxbenchmark>.

T = Terminated and U = Unterminated.

Note 2. Calculations are based on a 32.5/67.5 split between  $V_{MEMLX}$  used by the AMD Geode LX processor and series termination resistors. See Section 7.4.3 on page 599 for more details.

Note 3.  $V_{MEM}$  is 2.6V for the LX 800@0.9W processor.

Table 7-5. AMD Geode LX 700@0.8W Processor DC Currents

LX 700@0.8W (433 MHz), No EEPROM or EEPROM, $V_{CORE} = 1.20V$ , $TDP_T = 3.2W$ , $TDP_U = 3.1W$ (Note 1)					
Symbol	Parameter	Typ Avg	Max	Unit	Comments
$I_{CC3ON}$ - CRT Display	Power State: On (S0/C0)	85	100	mA	
$I_{CC3ON}$ - TFT Display		37	45		
$I_{COREON}$		650	1945		
$I_{MEMON}$ - Terminated		145	155		Note 2, Note 3
$I_{MEMON}$ - Unterminated		85	95		Note 3
$I_{MEMDDR2ON}$		75	90		
$I_{CC3IDLE}$ - CRT Display	Power State: Active Idle (S0/C1)	85		mA	
$I_{CC3IDLE}$ - TFT Display		37			
$I_{COREIDLE}$		555			
$I_{MEMIDLE}$ - Terminated		145			Note 2, Note 3
$I_{MEMIDLE}$ - Unterminated		75			Note 3
$I_{CC3SLP}$ - CRT Display		Power State: Sleep (S1)	4		
$I_{CC3SLP}$ - TFT Display	4				
$I_{CORESLP}$	195				
$I_{MEMSLP}$ - Terminated	95			Note 2, Note 3	
$I_{MEMSLP}$ - Unterminated	30			Note 3	

Note 1. The AMD Geode LX 700@0.8W processor operates at 433 MHz. Model numbers reflect performance as described here: <http://www.amd.com/connectivitysolutions/geodelxbenchmark>.

T = Terminated and U = Unterminated.

Note 2. Calculations are based on a 32.5/67.5 split between  $V_{MEMLX}$  used by the AMD Geode LX processor and series termination resistors. See Section 7.4.3 on page 599 for more details.

Note 3.  $V_{MEM}$  is 2.5V for the LX 700@0.8W processor.

Table 7-6. AMD Geode LX 600@0.7W Processor DC Currents

LX 600@0.7W (366 MHz), No EEPROM, $V_{CORE} = 1.20V$ , $TDP_T = 2.9W$ , $TDP_U = 2.8W$ (Note 1)					
Symbol	Parameter	Typ Avg	Max	Unit	Comments
$I_{CC3ON}$ - CRT Display	Power State: On (S0/C0)	85	100	mA	
$I_{CC3ON}$ - TFT Display		37	45		
$I_{COREON}$		600	1765		
$I_{MEMON}$ - Terminated		140	150		Note 2, Note 3
$I_{MEMON}$ - Unterminated		80	90		Note 3
$I_{MEMDDR2ON}$		70	85		
$I_{CC3IDLE}$ - CRT Display	Power State: Active Idle (S0/C1)	85		mA	
$I_{CC3IDLE}$ - TFT Display		37			
$I_{COREIDLE}$		510			
$I_{MEMIDLE}$ - Terminated		140			Note 2, Note 3
$I_{MEMIDLE}$ - Unterminated		70			Note 3
$I_{CC3SLP}$ - CRT Display		Power State: Sleep (S1)	4		
$I_{CC3SLP}$ - TFT Display	4				
$I_{CORESLP}$	185				
$I_{MEMSLP}$ - Terminated	90			Note 2, Note 3	
$I_{MEMSLP}$ - Unterminated	30			Note 3	

Note 1. The AMD Geode LX 600@0.7W processor operates at 366 MHz. Model numbers reflect performance as described here: <http://www.amd.com/connectivitysolutions/geodelxbenchmark>.

T = Terminated and U = Unterminated.

Note 2. Calculations are based on a 32.5/67.5 split between  $V_{MEMLX}$  used by the AMD Geode LX processor and series termination resistors. See Section 7.4.3 on page 599 for more details.

Note 3.  $V_{MEM}$  is 2.5V for the LX 600@0.7W processor.

## 7.5 DC Characteristics

All DC parameters and current measurements in this section were measured under the operating conditions listed in Table 7-2 "Operating Conditions", unless otherwise noted. The signals associated with the seven signal buffer types on the AMD Geode LX processor, are shown Table 3-5 "Ball Assignments - Sorted by Ball Number" on page 26.

**Table 7-7. DC Characteristics**

Symbol	Parameter	Min	Max	Units	Comments
V <sub>IL</sub>	Low Level Input Voltage, Note 1				
	PCI	-0.5	0.3*V <sub>IO</sub>	V	
	24/Q3	-0.5	0.8	V	
	24/Q5	-0.5	0.8	V	
	24/Q7	-0.5	0.8	V	
	5V	-0.5	0.8	V	
	DDR	-0.3	MVREF-0.2	V	
	DDRCLK	N/A	N/A		
V <sub>IH</sub>	High Level Input Voltage, Note 1				
	PCI	0.5*V <sub>IO</sub>	V <sub>IO</sub> +0.5	V	
	24/Q3	2.0	V <sub>IO</sub> +0.5	V	
	24/Q5	2.0	V <sub>IO</sub> +0.5	V	
	24/Q7	2.0	V <sub>IO</sub> +0.5	V	
	5V	2.0	5.5V	V	Overvoltage tolerant
	DDR	MVREF+0.2	V <sub>MEM</sub> +0.3	V	
	DDRCLK	N/A	N/A		
V <sub>OL</sub>	Low Level Output Voltage, Note 1				
	PCI		0.1*V <sub>IO</sub>	V	
	24/Q3		0.4	V	
	24/Q5		0.4	V	
	24/Q7		0.4	V	
	5V		0.4	V	
	DDR		0.35	V	
	DDRCLK		MVREF-0.4	V	
V <sub>OH</sub>	High Level Output Voltage, Note 1				
	PCI	0.9*V <sub>IO</sub>		V	
	24/Q3	2.4		V	
	24/Q5	2.4		V	
	24/Q7	2.4		V	
	5V	2.4		V	
	DDR	V <sub>MEM</sub> -0.43		V	
	DDRCLK	MVREF+0.4		V	

Table 7-7. DC Characteristics (Continued)

Symbol	Parameter	Min	Max	Units	Comments
I <sub>LEAK</sub>	Input Leakage Current Including Hi-Z Output Leakage, Note 1				
	PCI	-3.0	3.0	μA	
	24/Q3	-3.0	3.0	μA	
	24/Q5	-3.0	3.0	μA	
	24/Q7	-3.0	3.0	μA	
	5V	-3.0	3.0	μA	If V <sub>IH</sub> > V <sub>IO</sub> , I <sub>LEAK</sub> max = 20 μA
	DDR	-3.0	3.0	μA	
	DDRCLK	-5.0	5.0	μA	
I <sub>PU/PD</sub>	Weak Pull-Up/Down Current, Note 1				
	PCI	N/A		---	
	24/Q3	50	150	μA	These pull-downs are only enabled during reset or power sequencing system behaviors. Note 2.
	24/Q5	50	150	μA	
	24/Q7	50	150	μA	
	5V	50	150	μA	
	DDR	N/A		---	
	DDRCLK	N/A		---	
I <sub>OH</sub>	Output High Current, Note 1				V <sub>O</sub> = V <sub>OH</sub> (Min)
	PCI	-500		μA	
	24/Q3	-24.0		mA	
	24/Q5	-24.0		mA	
	24/Q7	-24.0		mA	Note 2
	5V	-16.0		mA	
	DDR (BA[1:0], MA[13:0])	-15.2		mA	I <sub>OH</sub> min = -11 mA with half-drive set for pad
	DDR (DQ[63:0], CKE[1:0], CS[3:0]#, RAS[1:0]#, CAS[1:0]#, WE[1:0]#, DQS[7:0], DQM[7:0], TLA[1:0])	-11		mA	I <sub>OH</sub> min = -8 mA with quarter-drive set for pad
	DDRCLK	-10.0		mA	

Table 7-7. DC Characteristics (Continued)

Symbol	Parameter	Min	Max	Units	Comments
I <sub>OL</sub>	Output Low Current, Note 1				V <sub>O</sub> = V <sub>OL</sub> (Max)
	PCI	1500		μA	
	24/Q3	24.0		mA	
	24/Q5	24.0		mA	
	24/Q7	24.0		mA	
	5V	16.0		mA	
	DDR (BA[1:0], MA[13:0])	15.2		mA	I <sub>OL</sub> min = 11 mA with half-drive set for pad
	DDR (DQ[63:0], CKE[1:0], CS[3:0]#, RAS[1:0]#, CAS[1:0]#, WE[1:0]#, DQS[7:0], DQM[7:0], TLA[1:0])	11		mA	I <sub>OL</sub> min = 8 mA with quarter-drive set for pad
DDRCLK	10.0		mA		
C <sub>IO</sub>	Input and Output Capacitance, Note 1				
	PCI		8.0	pF	
	24/Q3		5.0	pF	
	24/Q5		5.0	pF	
	24/Q7		5.0	pF	
	5V		5.0	pF	
	DDR		8.0	pF	
	DDRCLK		15.0	pF	

Note 1. Refer to the Table 3-5 "Ball Assignments - Sorted by Ball Number" on page 26 for package signal names associated with each buffer type.

Note 2. The SDA pad is designed to use a pull-up on-chip functionally, hence I<sub>OH</sub> is not used to drive high, I<sub>LEAK</sub> is instead

## 7.6 AC Characteristics

The following tables list the AC characteristics including output delays, input setup requirements, input hold requirements, and output float delays. The rising-clock-edge reference level  $V_{REF}$  and other reference levels are shown in Figure 7-2. Input or output signals must cross these levels during testing.

Input setup and hold times are specified minimums that define the smallest acceptable sampling window for which a synchronous input signal must be stable for correct operation.

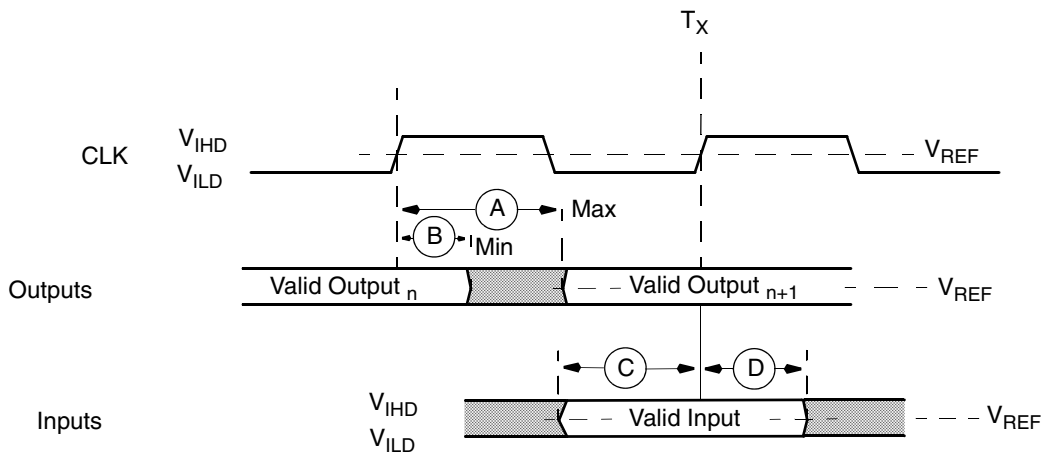
All AC tests are performed at the following parameters using the timing diagram shown in Figure 7-2 unless otherwise specified:

- $V_{CORE}$ : 1.14V to 1.26V (1.2V Nominal)
- $V_{IO}$ : 3.14V to 3.46V (3.3V Nominal)
- $V_{MEM}$ : 2.5V SSTL

- MVREF: DDR:1.25V
- $T_C$ : 0°C to 85°C
- $R_L$ : 50  $\Omega$
- $C_L$ : 50 pF

While most minimum, maximum, and typical AC characteristics are only shown as a single value, they are tested and guaranteed across the entire processor core voltage range of 1.14V to 1.26V. AC characteristics that are affected significantly by the core voltage or speed grade are documented accordingly.

All AC timing measurements are taken at 50% crossing points for both input times and output times.



- Legend:** A = Maximum Output or Float Delay Specification  
 B = Minimum Output or Float Delay Specification  
 C = Minimum Input Setup Specification  
 D = Minimum Input Hold Specification

**Figure 7-2. Drive Level and Measurement Points for Switching Characteristics**

Table 7-8. System Interface Signals

Symbol	Parameter	Min	Max	Unit	Comments
$t_{CK}$	SYSREF Cycle time	15.0	INF	ns	66 MHz
$t_{CH}$	SYSREF High time	6.0		ns	40% $t_{CK}$
$t_{CL}$	SYSREF Low time	6.0		ns	40% $t_{CK}$
$t_{SU1}$	RESET# Setup time to SYSREF	3		ns	Note 1
$t_{H1}$	RESET# Hold time from SYSREF	1		ns	Note 1
$t_{SU2}$	CIS Setup time to SYSREF	3.0		ns	
$t_{H2}$	CIS Hold time from SYSREF	0		ns	
$t_{VAL1}$	IRQ13 Valid Delay time from SYSREF	2.0	6.0	ns	
$t_{VAL2}$	SUSPA# Valid Delay time from SYSREF	2.0	6.0	ns	
$t_{ON}$	$V_{IO}$ and $V_{MEM}$ power on after $V_{CORE}$	0	100	ms	Note 2
$t_{MVON}$	MVREF power on after $V_{MEM}$	0	100	ms	
$t_{RSTX}$	Reset Active time after SYSREF clock stable	100		us	For PLL lock
$t_z$	Output drive delay after RESET# released		20	ns	

Note 1. RESET# is asynchronous. The setup/hold times stated are for testing purposes that require sequential repeatability.

Note 2. For proper powerup of DRGB and flat panel controls,  $V_{IO}$  must power up after  $V_{CORE}$ . Otherwise,  $V_{CORE}$  can be last.

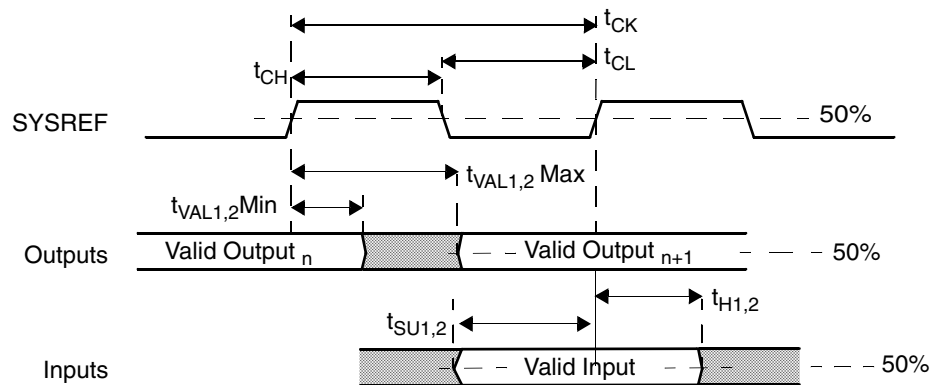


Figure 7-3. Drive Level and Measurement Points for Switching Characteristics



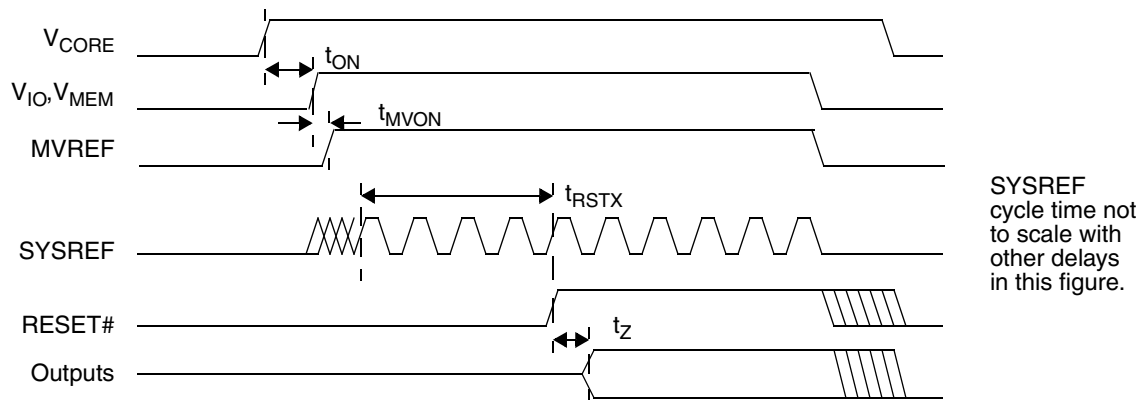


Figure 7-4. Power Up Sequencing

Table 7-9. PCI Interface Signals

Symbol	Parameter	Min	Max	Unit	Comments
$t_{SU1}$	Input Setup time to SYSREF (AD[31:0], DEVSEL#, GNT[2:0]#, IRDY#, PAR, STOP#, TRDY#)	3.0		ns	
$t_{SU2}$	REQ[2:0]# Input Setup time to SYSREF	4.5		ns	
$t_H$	Input Hold time from SYSREF for all PCI inputs (STOP#) (DEVSEL#, FRAME#, GNT[2:0]#, IRDY#, PAR, TRDY#, REQ[2:0]#, STOP#)	0		ns	Note 1
$t_{VAL1}$	Bused signals Valid Delay time from SYSREF (AD[31:0])	2.0	6.0	ns	Note 2
$t_{VAL2}$	GNT[2:0]# Valid Delay time from SYSREF	2.0	5.5	ns	Note 2

Note 1. The GNT[2:0]#, IRQ13, SUSPA#, PW0, and PW1 signals are only inputs during RESET# active. They must be stable between five and two PCI clocks before RESET# inactive.

Note 2. Output delay includes tristate-to-valid transitions and valid-to-tristate timing.

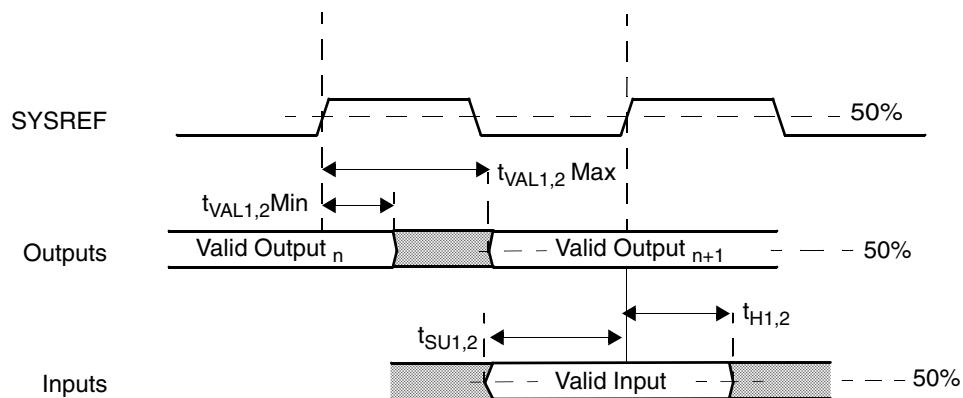


Figure 7-5. Drive Level and Measurement Points for Switching Characteristics

Table 7-10. VIP Interface Signals

Symbol	Parameter	Min	Max	Unit	Comments
$t_{CK}$	VIPCLK period	12.5		ns	80 MHz
$t_{CH}$	VIPCLK High time	3.0		ns	45% $t_{CK}$
$t_{CL}$	VIPCLK Low time	3.0		ns	45% $t_{CK}$
$t_{VAL}$	VIP_SYNC Output Valid Delay time from VIPCLK	1.0	4.0	ns	
$t_{SU1}$	VID[7:0] Input Setup time to VIPCLK	2.0		ns	
$t_{H1}$	VID[7:0] Input Hold time from VIPCLK.	0.2		ns	

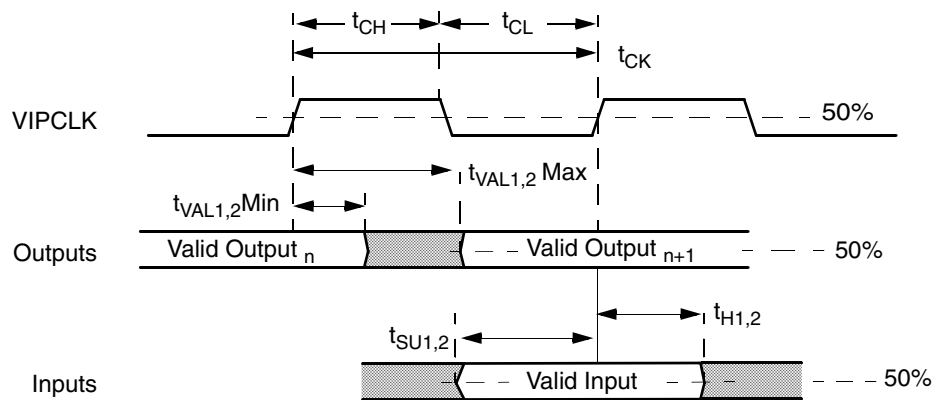
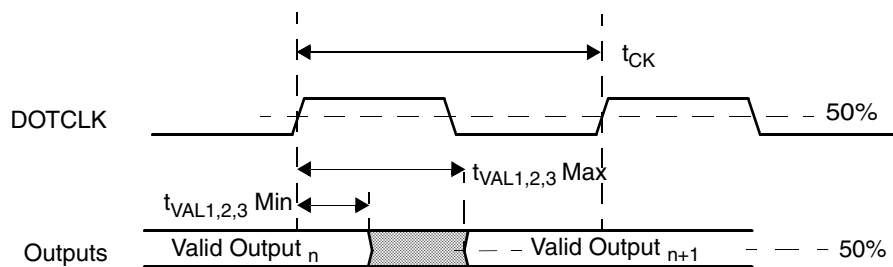


Figure 7-6. Drive Level and Measurement Points for Switching Characteristics

**Table 7-11. Flat Panel Interface Signals**

Symbol	Parameter	Min	Max	Unit	Comments
$t_{CK}$	DOTCLK period	6.0		ns	166 MHz
$t_{CH}$	DOTCLK High time	2.7		ns	45% $t_{CK}$
$t_{CL}$	DOTCLK Low time	2.7		ns	45% $t_{CK}$
	DOTCLK long term output jitter		15%	$t_{CK}$	Note 1
$t_{VAL1}$	DRGB[31:0] Output Valid Delay time from rising edge of DOTCLK	0.5	3.0	ns	
$t_{VAL2}$	DISPEN, LDEMODO Output Valid Delay time from rising edge of DOTCLK	0.5	3.0	ns	
$t_{VAL3}$	HSYNC, VSYNC Output Valid Delay time from rising edge of DOTCLK	0.5	3.0	ns	

Note 1. Measured as per VESA requirements. The jitter is observed at its worst case point on a scan line after HSYNC triggers up to and including the next HSYNC trigger.



**Figure 7-7. Drive Level and Measurement Points for Switching Characteristics**

Table 7-12. CRT Interface Signals

Symbol	Parameter	Min	Max	Unit	Comments
$t_{CK}$	DOTCLK Period	2.8		ns	350 MHz
$t_{CH}$	DOTCLK High time	1.2		ns	45% $t_{CK}$
$t_{CL}$	DOTCLK Low time	1.2		ns	45% $t_{CK}$
	DOTCLK long term output jitter		15%	$t_{CK}$	Note 1
$t_{SKEW}$	Skew between RED, GREEN, BLUE Output Valid	0	0.6	ns	Between any two signals Note 2

Note 1. Measured as per VESA requirements. The jitter is observed at its worst case point on a scan line after HSYNC triggers up to and including the next HSYNC trigger.

Note 2. HSYNC and VSYNC for CRT timing are generated from the same on-chip clock that is used to generate the RED, GREEN, and BLUE signals.

Table 7-13. CRT Display Recommended Operating Conditions

Symbol	Parameter	Min	Typ	Max	Units	Comments
$V_{DAC}$	Power Supply connected to $DAV_{DD}$	3.14	3.3	3.46	V	
$R_L$	Output Load RED, GREEN and BLUE		37.5 Note 1		$\Omega$	One each signal.
$I_{OUT}$	Output Current RED, GREEN and BLUE			21	mA	One each signal.
$R_{SET}$	Value of the full-scale adjust resistor connected to DRSET		1.2K		$\Omega$	This resistor should have a 1% tolerance.
$V_{EXT_{REF}}$	External voltage reference connected to the DVREF pin		1.235		V	

Note 1. There is a 75  $\Omega$  resistor on the motherboard and a 75  $\Omega$  resistor in the CRT monitor to create the effective 37.5  $\Omega$  typical resistance.

Table 7-14. CRT Display Analog (DAC) Characteristics

Symbol	Parameter	Min	Typ	Max	Units	Comments (Note 1)
$V_{OS}$	Output Voltage Saturation Limit	1.25			V	
$I_{OVAR}$	Output Current		18.67		mA	Achieves 700 mV on $37.5\Omega$
INL	Integral Linearity Error			+/-1	LSB	
DNL	Differential Linearity Error			+/-1	LSB	
$t_{FS}$	Full Scale Settling Time			2.5	ns	Note 2
--	DAC-to-DAC matching		1	4	%	
--	Analog Power Supply Rejection		45		dB	@ 1 KHz
$t_{RISE}$	Output Rise Time	0.5		1.25	ns	Note 3 and Note 4
$t_{FALL}$	Output Fall Time	0.5		1.25	ns	Note 3 and Note 4

Note 1. All tests, unless otherwise specified, are at  $V_{IO} = 3.14V$  to  $3.46V$ ,  $T_C = 0^\circ C$  to  $85^\circ C$  (or  $-40^\circ C$  to  $85^\circ C$  if LX 800@0.9w industrial temperature range part), and  $C_L = 50$  pF.

Note 2. Full-scale transition time is measured from 50% of full-scale transition until output remaining within 1LSB of target.

Note 3. Timing measurements are made with a  $75\Omega$  doubly-terminated load, with  $V_{EXT\_REF} = 1.235V$  and  $R_{SET} = 1.2$  K $\Omega$ .

Note 4. 10% to 90% of full-scale transition.

Table 7-15. Memory (DDR) Interface Signals

Symbol (Note 1)	Parameter	Min	Max	Unit	Comments
$t_{CK}$	SDCLK[5:0]P, SDCLK[5:0]N period	5.0		ns	Note 2
$t_{CH}$	SDCLK[5:0]P, SDCLK[5:0]N High time	2.4		ns	48% $t_{CK}$
$t_{CL}$	SDCLK[5:0]P, SDCLK[5:0]N Low time	2.4		ns	48% $t_{CK}$
$t_{SKEW1}$	SDCLK[n]P to SDCLK[n]N skew (n=0..5)		0.1	ns	Guaranteed by design
$t_{DEL1}$	SDCLK[5:1]P, SDCLK[5:0]N edge delay from SDCLK[0]P	-0.2	0.2	ns	Note 2, Note 3
	DQS[7:0] Input and output period	5.0		ns	Same as $t_{CK}$
$t_{DQSK}$	DQS[7:0] Input delay relative to SDCLK[5:0]	-0.5	$t_{CK}-2$	ns	Note 4
$t_{DEL2}$	DQS[7:0] output edge delay from SDCLK[5:0]	-0.5	0.5	ns	Note 3
$t_{RPRE}$	DQS input preamble before first DQS rising edge	$0.25*t_{CK}$		ns	Note 3
$t_{RPST}$	DQS input postamble after last DQS rising edge	$0.25*t_{CK}$			Note 3
$t_{WPRE}$	DQS output write preamble valid time before SDCLK[5:0] rising edge	$0.5*t_{CK}-0.4$	$0.5*t_{CK}+1$	ns	
$t_{WPST}$	DQS output write postamble after last DQS falling edge	$0.75*t_{CK}-0.4$	$0.75*t_{CK}+1$	ns	
$t_{DQSQs}$	DQ[63:0] Input setup time from DQS	$-0.25*t_{CK}+0.5$		ns	Note 3, Note 5
$t_{DQSQh}$	DQ[63:0] Input hold time from DQS	$0.25*t_{CK}+0.5$		ns	Note 3, Note 5
$t_{VAL1}$	DQ[63:0], DQM[7:0] Output Data Valid Delay time from DQS rising OR falling edge	$0.25*t_{CK}-0.4$	$0.25*t_{CK}+0.4$	ns	Note 3,
$t_{VAL2}$	MA[12:0], BA[1:0], CAS[1:0]#, RAS[1:0]#, CKE[1:0], CS[3:0]#, WE[1:0] Output Valid Delay time from SDCLK[5:0]	1.1	3.0	ns	Note 3, Note 4

Note 1. Refer to Figure 7-8 "DDR Write Timing Measurement Points" on page 615 and Figure 7-9 "DDR Read Timing Measurement Points" on page 616.

Note 2. The SDCLKP and SDCLKN clocks are inversions of each other (differential clocking).

Note 3. These parameters guarantee device timing, but they may be tested to a looser value to allow for tester uncertainties. Devices that meet the loosened tester values meet specs when correlated with lab measurements.

Note 4.  $t_{VAL2}$  and  $t_{DQSK}$  timings are achieved for different DIMM loadings by proper initial settings of the GLCP\_DELAY\_CONTROLS MSR. Typical tester results with clock and address loaded equally and no programmed delay for address are 0 ns for  $t_{VAL2}$ .

Note 5. The DQ timing relative to DQS are on a per-byte basis only. DQ[7:0] and DQM[0] should be measured against DQS[0], DQ[15:8] and DQM[1] should be measured against DQS[1], etc.

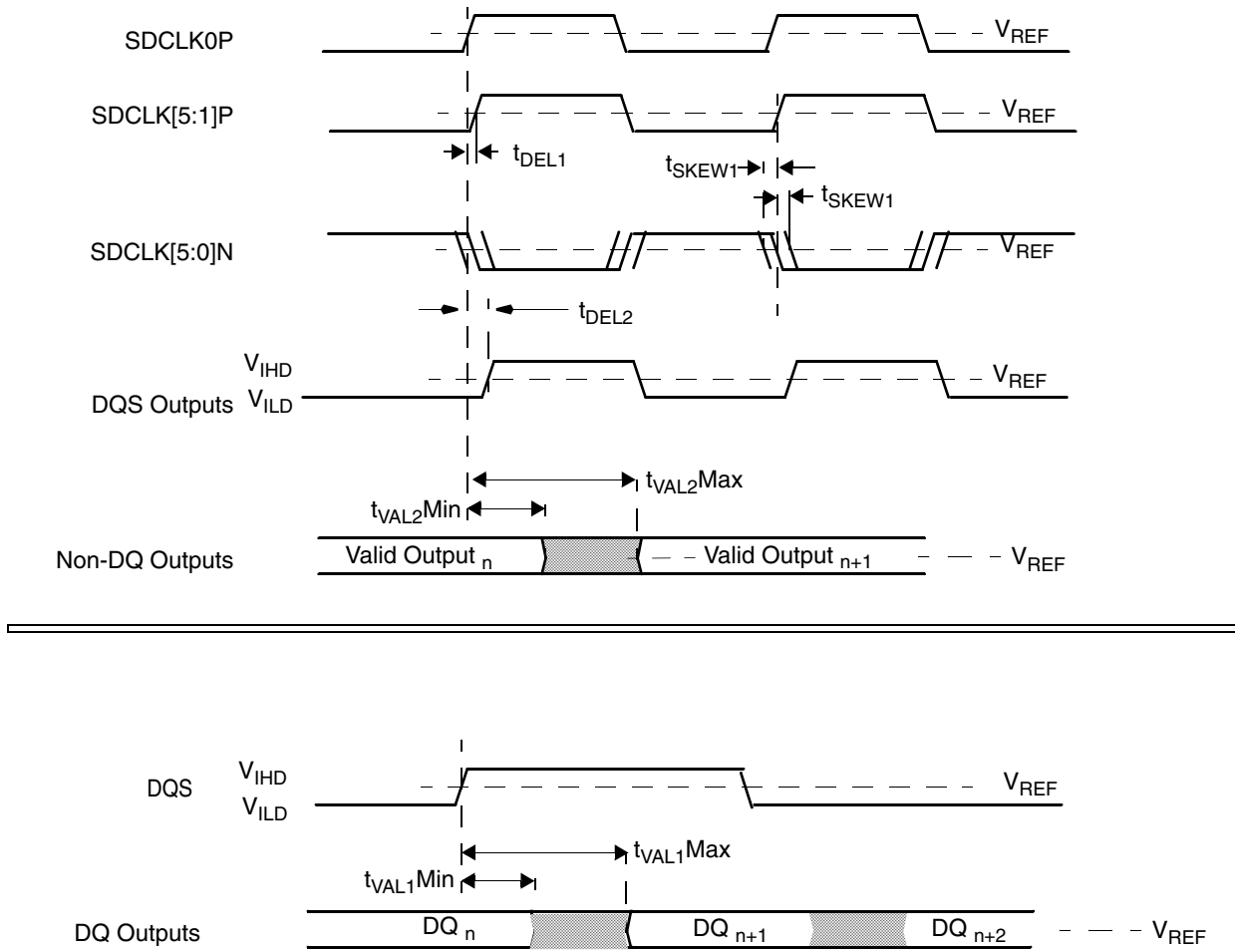


Figure 7-8. DDR Write Timing Measurement Points

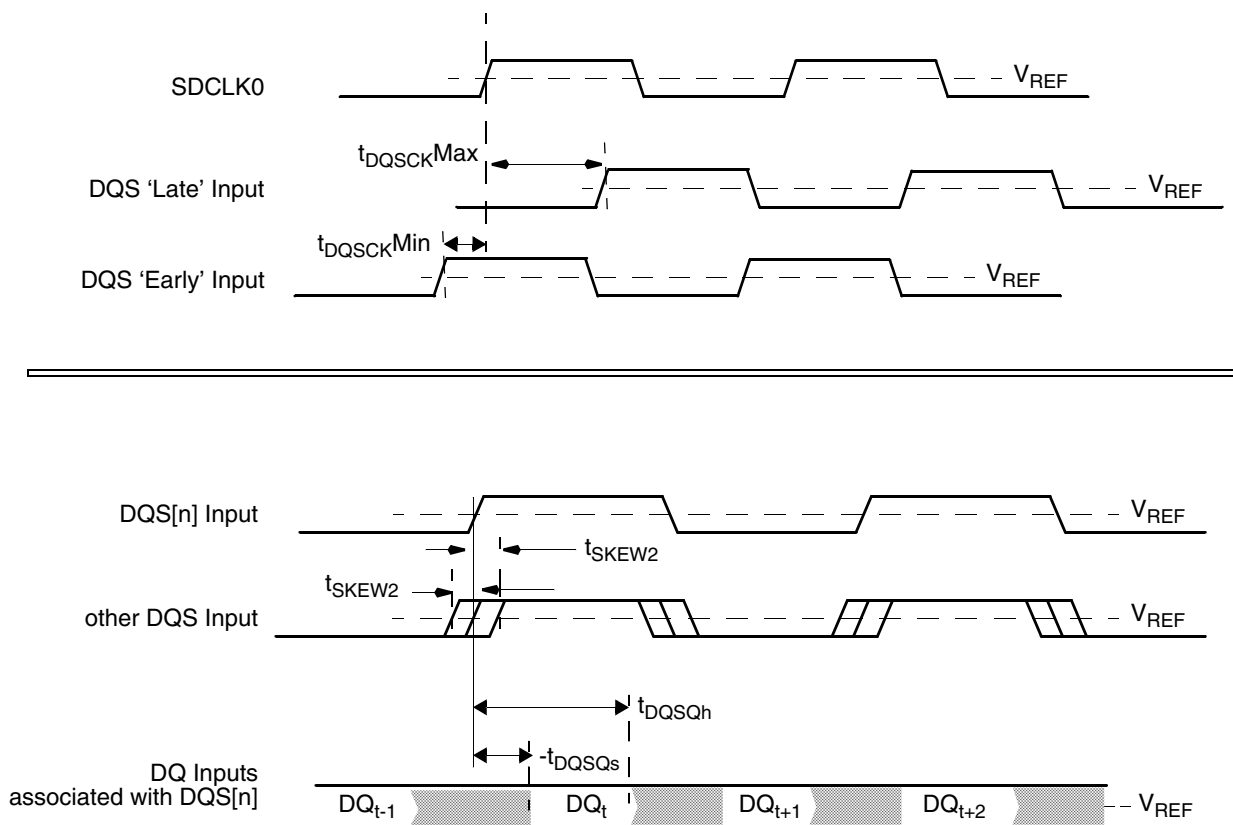


Figure 7-9. DDR Read Timing Measurement Points



Table 7-16. JTAG Interface Signals

Symbol	Parameter	Min	Max	Unit	Comments
	TCLK period	15		ns	Note 1
	TCLK High time	4		ns	40% period
	TCLK Low time	4		ns	40% period
	TDI, TMS Setup time to TCLK rising edge	1.5		ns	
	TMS Hold time from TCLK rising edge	3.0		ns	
	TDI Hold time from TCLK rising edge - Boundary scan	3.0		ns	
	TDI Hold time from TCLK rising edge - Functional	$2 \cdot T_{\text{GLBus}}$		ns	Hold for 2 GLBus clocks
	TDO Output Valid Delay time from TCLK falling edge when running boundary scan test	3.0	70.0	ns	
	TDO Output Valid Delay time from TCLK falling edge in normal functional mode	3.0	10.0	ns	
	All chip I/O Setup time to TCLK rise - boundary scan	1.0		ns	
	All chip I/O Hold time from TCLK rise - boundary scan	3		ns	
	All chip I/O Output Valid Delay time from TCLK falling edge - boundary scan test	2.0	70.0	ns	

Note 1. TCLK limited during functional mode to 100 MHz or 1/4 of the memory data frequency.



# Instruction Set

This chapter provides the general instruction set format and detailed information on the AMD Geode™ LX processor's instructions/instruction encodings. The instruction set is divided into three categories:

- CPUID Instruction Set - listed in Section 8.2 on page 627.
- Processor Core Instruction Set - listed in Section 8.3 on page 633.
- MMX™, FPU, and AMD 3DNow!™ Instruction Sets (including extensions) - listed in Section 8.4 on page 658.

In the above listed sections are tables that provide information on the instruction encoding, and the instruction clock counts for each instruction. The clock count values for these tables are based on the following assumptions:

- 1) All clock counts refer to the internal processor core clock frequency.
- 2) The instruction has been prefetched, decoded, and is ready for execution.
- 3) Any needed memory operands are in the cache in the last accessed way (i.e., Way0, Way1, Way2, or Way3). Add two clocks if not in last accessed way.
- 4) No exceptions are detected during instruction execution.
- 5) If an effective address is calculated, it does not use two general register components. One register, scaling, and a displacement value can be used within the clock count shown. However, if the effective address calculation uses a base register, an index register, and a displacement value, a cycle must be added to the count.
- 6) All clock counts assume an 8-byte span of 32-bit memory/IO operands.
- 7) If instructions access a 32-bit operand not within an 8-byte block, add one clock for read or write and add two clocks for read and write.
- 8) For non-cached memory accesses, add several clocks. Cache miss accesses are approximately an additional 25 clocks, the exact number depends upon the cycle/operation running.
- 9) Locked cycles are not cacheable. Therefore, using the LOCK prefix with an instruction adds additional clocks as specified in item 8 above.

## 8.1 General Instruction Set Format

Depending on the instruction, the AMD Geode LX processor core instructions follow the general instruction format shown in Table 8-1. These instructions vary in length and can start at any byte address. An instruction consists of one or more bytes that can include prefix bytes, at least one opcode byte, a mod r/m byte, an s-i-b byte, address displacement, and immediate data. An instruction can be as short as one byte and as long as 15 bytes. If there are more than 15 bytes in the instruction, a general protection fault (error code 0) is generated.

The fields in the general instruction format at the byte level are summarized in Table 8-2 on page 620 and detailed in the following subsections.

**Table 8-1. General Instruction Set Format**

Prefix (Optional)	Opcode	Register and Address Mode Specifier						Address Displacement	Immediate Data
		mod r/m Byte			s-i-b Byte				
		mod	reg	r/m	ss	index	base		
0 or More Bytes	1 or 2 Bytes	7:6	5:3	2:0	7:6	5:3	2:0	0, 8, 16, or 32 Bits	0, 8, 16, or 32 Bits

**Table 8-2. Instruction Fields**

Field Name	Description
Prefix (optional)	Prefix Field(s): One or more optional fields that are used to specify segment register override, address and operand size, repeat elements in string instruction, and LOCK# assertion.
Opcode	Opcode Field: Identifies instruction operation.
mod	Address Mode Specifier: Used with the r/m field to select addressing mode.
reg	General Register Specifier: Uses reg, sreg3, or sreg2 encoding depending on opcode field.
r/m	Address Mode Specifier: Used with mod field to select addressing mode.
ss	Scale factor: Determines scaled-index address mode.
index	Index: Determines general register to be used as index register.
base	Base: Determines general register to be used as base register.
Address Displacement	Displacement: Determines address displacement.
Immediate Data	Immediate Data: Immediate data operand used by instruction.

### 8.1.1 Prefix (Optional)

Prefix bytes can be placed in front of any instruction to modify the operation of that instruction. When more than one prefix is used, the order is not important. There are five types of prefixes that can be used:

- 1) Segment Override explicitly specifies which segment register the instruction will use for effective address calculation.
- 2) Address Size switches between 16-bit and 32-bit addressing by selecting the non-default address size.
- 3) Operand Size switches between 16-bit and 32-bit operand size by selecting the non-default operand size.
- 4) Repeat is used with a string instruction to cause the instruction to be repeated for each element of the string.

Table 8-3 lists the encoding for different types of prefix bytes.

**Table 8-3. Instruction Prefix Summary**

Prefix	Encoding	Description
ES:	26h	Override segment default, use ES for memory operand.
CS:	2Eh	Override segment default, use CS for memory operand.
SS:	36h	Override segment default, use SS for memory operand.
DS:	3Eh	Override segment default, use DS for memory operand.
FS:	64h	Override segment default, use FS for memory operand.
GS:	65h	Override segment default, use GS for memory operand.
Operand Size	66h	Make operand size attribute the inverse of the default.
Address Size	67h	Make address size attribute the inverse of the default.
LOCK	F0h	Assert LOCK# internal hardware signal.
REPNE	F2h	Repeat the following string instruction.
REP/REPE	F3h	Repeat the following string instruction.

## 8.1.2 Opcode

The opcode field specifies the operation to be performed by the instruction. The opcode field is either one or two bytes in length and may be further defined by additional bits in the mod r/m byte. Some operations have more than one opcode, each specifying a different form of the operation. Certain opcodes name instruction groups. For example, opcode 80h names a group of operations that have an immediate operand and a register or memory operand. The reg field may appear in the second opcode byte or in the mod r/m byte.

The opcode may contain w, d, s, and eee opcode fields, for example, as shown in Table 8-26 on page 634.

### 8.1.2.1 w Field (Operand Size)

When used, the 1-bit w field selects the operand size during 16-bit and 32-bit data operations. See Table 8-4.

**Table 8-4. w Field Encoding**

w Field	Operand Size	
	16-Bit Data Operations	32-Bit Data Operations
0	8 bits	8 bits
1	16 bits	32 bits

### 8.1.2.2 d Field (Operand Direction)

When used, the 1-bit d field determines which operand is taken as the source operand and which operand is taken as the destination. See Table 8-5.

**Table 8-5. d Field Encoding**

d Field	Direction of Operation	Source Operand	Destination Operand
0	Register-to-Register or Register-to-Memory	reg	mod r/m or mod ss-index-base
1	Register-to-Register or Memory-to-Register	mod r/m or mod ss-index-base	reg

### 8.1.2.3 s Field (Immediate Data Field Size)

When used, the 1-bit s field determines the size of the immediate data field. If the s bit is set, the immediate field of the opcode is 8 bits wide and is sign-extended to match the operand size of the opcode. See Table 8-6.

**Table 8-6. s Field Encoding**

s Field	Immediate Field Size		
	8-Bit Operand Size	16-Bit Operand Size	32-Bit Operand Size
0 (or not present)	8 bits	16 bits	32 bits
1	8 bits	8 bits (sign-extended)	8 bits (sign-extended)

### 8.1.2.4 eee Field (MOV-Instruction Register Selection)

The eee field (bits [5:3]) is used to select the control, debug, and test registers in the MOV instructions. The type of register and base registers selected by the eee field are listed in Table 8-7. The values shown in Table 8-7 are the only valid encodings for the eee bits.

**Table 8-7. eee Field Encoding**

eee Field	Register Type	Base Register
000	Control Register	CR0
010	Control Register	CR2
011	Control Register	CR3
100	Control Register	CR4
000	Debug Register	DR0
001	Debug Register	DR1
010	Debug Register	DR2
011	Debug Register	DR3
110	Debug Register	DR6
111	Debug Register	DR7
000	Test Register	TR0
001	Test Register	TR1
010	Test Register	TR2
011	Test Register	TR3
100	Test Register	TR4
101	Test Register	TR5
110	Test Register	TR6
111	Test Register	TR7

### 8.1.3 mod and r/m Byte (Memory Addressing)

The mod and r/m fields within the mod r/m byte select the type of memory addressing to be used. Some instructions use a fixed addressing mode (e.g., PUSH or POP) and therefore, these fields are not present. Table 8-8 lists the addressing method when 16-bit addressing is used and a mod r/m byte is present. Some mod r/m field encodings are dependent on the w field and are shown in Table 8-9.

**Table 8-8. mod r/m Field Encoding**

mod Field	r/m Field	16-Bit Address Mode with mod r/m Byte (Note 1)	32-Bit Address Mode with mod r/m Byte and No s-i-b Byte Present (Note 1)
00	000	DS:[BX+SI]	DS:[EAX]
00	001	DS:[BX+DI]	DS:[ECX]
00	010	SS:[BP+SI]	DS:[EDX]
00	011	SS:[BP+DI]	DS:[EBX]
00	100	DS:[SI]	s-i-b is present (See Table 8-15 on page 626)
00	101	DS:[DI]	DS:[d32]
00	110	DS:[d16]	DS:[ESI]
00	111	DS:[BX]	DS:[EDI]

**Table 8-8. mod r/m Field Encoding (Continued)**

mod Field	r/m Field	16-Bit Address Mode with mod r/m Byte (Note 1)	32-Bit Address Mode with mod r/m Byte and No s-i-b Byte Present (Note 1)
01	000	DS:[BX+SI+d8]	DS:[EAX+d8]
01	001	DS:[BX+DI+d8]	DS:[ECX+d8]
01	010	SS:[BP+SI+d8]	DS:[EDX+d8]
01	011	SS:[BP+DI+d8]	DS:[EBX+d8]
01	100	DS:[SI+d8]	s-i-b is present (See Table 8-15 on page 626)
01	101	DS:[DI+d8]	SS:[EBP+d8]
01	110	SS:[BP+d8]	DS:[ESI+d8]
01	111	DS:[BX+d8]	DS:[EDI+d8]
10	000	DS:[BX+SI+d16]	DS:[EAX+d32]
10	001	DS:[BX+DI+d16]	DS:[ECX+d32]
10	010	SS:[BP+SI+d16]	DS:[EDX+d32]
10	011	SS:[BP+DI+d16]	DS:[EBX+d32]
10	100	DS:[SI+d16]	s-i-b is present (See Table 8-15 on page 626)
10	101	DS:[DI+d16]	SS:[EBP+d32]
10	110	SS:[BP+d16]	DS:[ESI+d32]
10	111	DS:[BX+d16]	DS:[EDI+d32]
11	xxx	See Table 8-9.	See Table 8-9

Note 1. d8 refers to 8-bit displacement, d16 refers to 16-bit displacement, and d32 refers to a 32-bit displacement.

**Table 8-9. General Registers Selected by mod r/m Fields and w Field**

mod	r/m	16-Bit Operation		32-Bit Operation	
		w = 0	w = 1	w = 0	w = 1
11	000	AL	AX	AL	EAX
11	001	CL	CX	CL	ECX
11	010	DL	DX	DL	EDX
11	011	BL	BX	BL	EBX
11	100	AH	SP	AH	ESP
11	101	CH	BP	CH	EBP
11	110	DH	SI	DH	ESI
11	111	BH	DI	BH	EDI

### 8.1.4 reg Field

The reg field (Table 8-10) determines which general registers are to be used. The selected register is dependent on whether a 16-bit or 32-bit operation is current and on the status of the w bit.

**Table 8-10. reg Field**

reg	16-Bit Operation		32-Bit Operation	
	w = 0	w = 1	w = 0	w = 1
000	AL	AX	AL	EAX
001	CL	CX	CL	ECX
010	DL	DX	DL	EDX
011	BL	BX	BL	EBX
100	AH	SP	AH	ESP
101	CH	BP	CH	EBP
110	DH	SI	DH	ESI
111	BH	DI	BH	EDI

#### 8.1.4.1 sreg2 Field (ES, CS, SS, DS Register Selection)

The sreg2 field (Table 8-11) is a 2-bit field that allows one of the four 286-type segment registers to be specified.

**Table 8-11. sreg2 Field Encoding**

sreg2 Field	Segment Register Selected
00	ES
01	CS
10	SS
11	DS

#### 8.1.4.2 sreg3 Field (FS and GS Segment Register Selection)

The sreg3 field (Table 8-12) is 3-bit field that is similar to the sreg2 field, but allows use of the FS and GS segment registers.

**Table 8-12. sreg3 Field (FS and GS Segment Register Selection)**

sreg3 Field	Segment Register Selected
000	ES
001	CS
010	SS
011	DS
100	FS
101	GS
110	Undefined
111	Undefined



### 8.1.5 s-i-b Byte (Scale, Indexing, Base)

The s-i-b fields provide scale factor, indexing, and a base field for address selection. The ss, index, and base fields are described next.

#### 8.1.5.1 ss Field (Scale Selection)

The ss field (Table 8-13) specifies the scale factor used in the offset mechanism for address calculation. The scale factor multiplies the index value to provide one of the components used to calculate the offset address.

**Table 8-13. ss Field Encoding**

ss Field	Scale Factor
00	x1
01	x2
01	x4
11	x8

#### 8.1.5.2 Index Field (Index Selection)

The index field (Table 8-14) specifies the index register used by the offset mechanism for offset address calculation. When no index register is used (index field = 100), the ss value must be 00 or the effective address is undefined.

**Table 8-14. index Field Encoding**

Index Field	Index Register
000	EAX
001	ECX
010	EDX
011	EBX
100	none
101	EBP
110	ESI
111	EDI

### 8.1.5.3 Base Field (s-i-b Present)

In Table 8-8 on page 622, the note “s-i-b is present” for certain entries forces the use of the mod and base field as listed in Table 8-15. The first two digits in the first column of Table 8-15 identify the mod bits in the mod r/m byte. The last three digits in the second column of this table identify the base fields in the s-i-b byte.

**Table 8-15. mod base Field Encoding**

mod Field within mod/rm Byte (bits[7:6])	base Field within s-i-b Byte (bits [2:0])	32-Bit Address Mode with mod r/m and s-i-b Bytes Present
00	000	DS:[EAX+(scaled index)]
00	001	DS:[ECX+(scaled index)]
00	010	DS:[EDX+(scaled index)]
00	011	DS:[EBX+(scaled index)]
00	100	SS:[ESP+(scaled index)]
00	101	DS:[d32+(scaled index)]
00	110	DS:[ESI+(scaled index)]
00	111	DS:[EDI+(scaled index)]
01	000	DS:[EAX+(scaled index)+d8]
01	001	DS:[ECX+(scaled index)+d8]
01	010	DS:[EDX+(scaled index)+d8]
01	011	DS:[EBX+(scaled index)+d8]
01	100	SS:[ESP+(scaled index)+d8]
01	101	SS:[EBP+(scaled index)+d8]
01	110	DS:[ESI+(scaled index)+d8]
01	111	DS:[EDI+(scaled index)+d8]
10	000	DS:[EAX+(scaled index)+d32]
10	001	DS:[ECX+(scaled index)+d32]
10	010	DS:[EDX+(scaled index)+d32]
10	011	DS:[EBX+(scaled index)+d32]
10	100	SS:[ESP+(scaled index)+d32]
10	101	SS:[EBP+(scaled index)+d32]
10	110	DS:[ESI+(scaled index)+d32]
10	111	DS:[EDI+(scaled index)+d32]

## 8.2 CPUID Instruction Set

The CPUID instruction (opcode 0FA2) allows software to make processor inquiries as to the vendor, family, model, stepping, features, and specific cache organization information. The presence of support for the CPUID instruction is indicated by the ability to change the value of the ID flag, bit 21, in the EFLAGS register.

The CPUID level allows the CPUID instruction to return different information in EAX, EBX, ECX, and EDX registers. The level is determined by the initialized value of the EAX register prior to execution of the CPUID instruction.

### 8.2.1 Standard CPUID Levels

The standard CPUID levels are part of the standard x86 instruction set.

#### 8.2.1.1 CPUID Instruction with EAX = 0000000h

Standard function 0000000h (EAX = 0000000h) of the CPUID instruction returns the maximum standard CPUID levels, as well as the processor vendor string.

After the instruction is executed, the EAX register contains the maximum standard CPUID levels supported. The maximum standard CPUID level is the highest acceptable value for the EAX register input. This does not include the extended CPUID levels.

The EBX through EDX registers contain the vendor string of the processor as shown in Table 8-16.

#### 8.2.1.2 CPUID Instruction with EAX = 0000001h

Standard function 0000001h (EAX = 0000001h) of the CPUID instruction returns the processor type, family, model, stepping information in the EAX register, and the supported standard feature flags in the EDX register. The EBX and ECX registers are reserved. Table 8-17 provides a register map.

In the EDX register, each flag refers to a specific feature. Some of these features have protection control in CR4. Before using any of these features, the software should check the corresponding feature flag. Attempting to execute an unavailable feature can cause exceptions and unexpected behavior. For example, software must check EDX[4] before attempting to use the Time Stamp Counter instruction.

Table 8-18 on page 628 shows the EAX and EDX bit field formats when EAX = 0000001h and indicates if a feature is not supported.

**Table 8-16. CPUID Instruction with EAX = 0000000h**

Register (Note 1)	Returned Contents	Description	Comment
EAX	00000001h	Maximum Standard Level	
EBX	68747541h {htuA}	Vendor ID String 1	
EDX	69746E65h {itne}	Vendor ID String 2	
ECX	444D4163h {DMAc}	Vendor ID String 3	

Note 1. The “Register” column is intentionally out of order.

**Table 8-17. CPUID Instruction with EAX = 0000001h**

Register	Returned Contents	Description	Comment
EAX	000005Axh	Type/Family/Model/Step	
EBX	00000400h	Reserved	
ECX	00000000h	Reserved	
EDX	0088A93Dh	Standard Feature Flags	

Table 8-18. CPUID Instruction Codes with EAX = 00000000

Register	Reset Value	Description	Comment
EAX[31:28]	0x0	Reserved	
EAX[27:20]	0x00	Extended Family	
EAX[19:16]	0x00	Extended Model	
EAX[15:12]	0x0	Reserved	
EAX[11:8]	0x5	Processor/Instruction Family	
EAX[7:4]	0xA	Processor Model	
EAX[3:0]	0x2	Processor Stepping	May change with CPU revision
EBX[31:24]	0x00	Initial local APCI physical ID	
EBX[23:16]	0x00	Reserved	
EBX[15:08]	0x04	CLFLUSH cache line size in QWORD - 8 byte increments	
EBX[7:0]	0x00	8-bit brand ID	
EDX[31:27]	0000	Reserved	
EDX[26]	0	XMM2. Streaming SIMD Extensions	Not supported
EDX[25]	0	XMM. Streaming SIMD Extensions	Not supported
EDX[24]	0	FXSR. Fast FP Save and Restore	Not supported
EDX[23]	1	MMX™. MMX Instruction Set and Architecture	
EDX[22:20]	000	Reserved	
EDX[19]	1	CLFSH. CLFLUSH feature is supported	
EDX[18]	0	PN. 96-Bit Serial Number Feature	Not supported
EDX[17]	0	PSE36. 36-Bit Page Size Extensions	Not supported
EDX[16]	0	PAT. Page Attribute Table	Not supported
EDX[15]	1	CMOV. Conditional Move Instruction	
EDX[14]	0	MCA. Machine Check Architecture	Not supported
EDX[13]	1	PGE. Page Global Enable Feature	
EDX[12]	0	MTRR. Memory Type Range Registers	Not supported
EDX[11]	1	SEP. Sysenter/Sysexit Instruction	
EDX[10]	0	Reserved	
EDX[9]	0	APIC. Advanced Programmable Interrupt	Not supported
EDX[8]	1	CX8. Compare Exchange (CMPXCHG8B) Instruction	
EDX[7]	0	MCE. Machine Check Exception	Not supported
EDX[6]	0	PAE. Page Address Extension	Not supported
EDX[5]	1	MSR. Model Specific Registers via RDMSR/WRMSR Instructions	
EDX[4]	1	TSC. Time Stamp Counter and RDTSC Instruction	
EDX[3]	1	PSE. 4 MB Page Size Extension	
EDX[2]	1	DE. Debugging Extension	

**Table 8-18. CPUID Instruction Codes with EAX = 00000000**

Register	Reset Value	Description	Comment
EDX[1]	0	VME. Virtual Interrupt Flag in VM86	Not supported
EDX[0]	1	FPU. Floating Point Unit On Chip	

### 8.2.2 Extended CPUID Levels

Testing for extended CPUID instruction support can be accomplished by executing a CPUID instruction with the EAX register initialized to 80000000h. If a value greater than or equal to 80000000h is returned to the EAX register by the CPUID instruction, the processor supports extended CPUID levels.

#### 8.2.2.1 CPUID Instruction with EAX = 80000000h

Extended function 80000000h (EAX = 80000000h) of the CPUID instruction returns the maximum extended CPUID supported levels as well as the processor vendor string.

After the instruction is executed, the EAX register contains the maximum extended CPUID levels supported. The maximum extended standard CPUID level is the highest acceptable value for the EAX register input.

The EBX through EDX registers contain the vendor string of the processor as shown in Table 8-19.

#### 8.2.2.2 CPUID Instruction with EAX = 80000001h

Extended function 80000001h (EAX = 80000001h) of the CPUID instruction returns the processor type, family, model, stepping information in the EAX register, and the supported extended feature flags in the EDX register. The EBX and ECX registers are reserved. Table 8-20 provides a register map.

In the EDX register, each flag refers to a specific extended feature. Some of these features have protection control in CR4. Before using any of these extended features, the software should check the corresponding flag. Attempting to execute an unavailable extended feature can cause exceptions and unexpected behavior.

Table 8-21 on page 630 shows the EAX and EDX bit field formats when EAX = 80000001h and indicates if a feature is not supported.

**Table 8-19. CPUID Instruction with EAX = 80000000h**

Register (Note 1)	Returned Contents	Description	Comment
EAX	80000006h	Maximum Extended CPUID Level	
EBX	68747541h {htuA}	Vendor ID String 1	
EDX	69746E65h {itne}	Vendor ID String 2	
ECX	444D4163h {DMAc}	Vendor ID String 3	

Note 1. The "Register" column is intentionally out of order.

**Table 8-20. CPUID Instruction with EAX = 80000001h**

Register	Returned Contents	Description	Comment
EAX	000005Axh	Type/Family/Model/Step	
EBX	00000000h	Reserved	
ECX	00000000h	Reserved	
EDX	C0C0A13Dh	Feature Flags	

Table 8-21. CPUID Instruction Codes with EAX = 8000001h

Register	Reset Value	Description	Comment
EAX[31:28]	0x0	Reserved	
EAX[27:20]	0x00	Extended Family	
EAX[19:16]	0x00	Extended Model	
EAX[15:12]	0x0	Reserved	
EAX[11:8]	0x5	Processor/Instruction Family	
EAX[7:4]	0x5	Processor Model	
EAX[3:0]	0x2	Processor Stepping	May change with CPU revision
EDX[31]	1	3DN. 3DNow! Instruction Set	
EDX[30]	1	3DE. 3DNow! Instruction Set Extension	
EDX[29]	0	LM. Long mode	Not supported
EDX[28:25]	0000	Reserved	Not supported
EDX[24]	0	FXSR/FXRSTOR. Fast FP Save and Restore	Not supported
EDX[23]	1	MMX. MMX Instruction Set and Architecture	
EDX[22]	1	AMMX. AMD MMX Instruction Extension	
EDX[21]	0	Reserved	
EDX[20]	0	NX. No-execute page protection	Not supported
EDX[19]	0	MP. Multiprocessing capability	Not supported
EDX[18]	0	Reserved	
EDX[17]	0	PSE36. 36-Bit Page Size Extensions	Not supported
EDX[16]	0	PAT. Page Attribute Table	Not supported
EDX[15]	1	CMOV. Conditional Move Instruction (CMOV, FCMOV, FCOMI)	
EDX[14]	0	MCA. Machine Check Architecture	Not supported
EDX[13]	1	PGE. Page Global Enable Feature	
EDX[12]	0	MTRR. Memory Type Range Registers	Not supported
EDX[11]	0	ASEP. Syscall/Sysret Instruction	
EDX[10]	0	Reserved	
EDX[9]	0	APIC. Advanced Programmable Interrupt Controller	Not supported
EDX[8]	1	CX8. Compare Exchange (CMPXCHG8B) Instruction	
EDX[7]	0	MCE. Machine Check Exception	Not supported
EDX[6]	0	PAE. Page Address Extension	Not supported
EDX[5]	1	MSR. Model Specific Registers via RDMSR/WRMSR Instructions	
EDX[4]	1	TSC. Time Stamp Counter and RDTSC Instruction	
EDX[3]	1	PSE. 4MB Page Size Extension	
EDX[2]	1	DE. Debugging Extension	
EDX[1]	0	VME. Virtual Interrupt Flag in VM86	Not supported
EDX[0]	1	FPU. Floating Point Unit On Chip	

**8.2.2.3 CPUID Instruction with EAX = 8000002h, 8000003h, or 8000004h**

Extended functions 8000002h through 8000004h (EAX = 8000002h, EAX = 8000003h, and EAX = 8000004h) of the CPUID instruction returns an ASCII string containing the CPU marketing name, as shown in Table 8-22. These functions eliminate the need to look up the processor name in a lookup table. Software can simply call these functions to obtain the name of the processor. The string may be 48 ASCII characters long, and is returned in little endian format. If the name is shorter than 48 characters long, the remaining bytes are filled with ASCII NUL characters (00h).

**Table 8-22. CPUID Instruction with EAX = 8000002h, 8000003h, or 8000004h**

Register	Returned Contents	Description	Comment
<b>EAX = 8000002h</b>			
EAX	646F6547h	{doeG}	CPU Marketing Name 1a
EBX	4D542865h	{MT)e}	CPU Marketing Name 1b
ECX	6E492029h	{nl {}	CPU Marketing Name 2a
EDX	72676574h	{rget}	CPU Marketing Name 2b
<b>EAX = 8000003h</b>			
EAX	64657461h	{deta}	CPU Marketing Name 3a
EBX	6F725020h	{orP}	CPU Marketing Name 3b
ECX	73736563h	{ssec}	CPU Marketing Name 4a
EDX	6220726Fh	{b ro}	CPU Marketing Name 4b
<b>EAX = 8000004h</b>			
EAX	4D412079h	{MA y}	CPU Marketing Name 5a
EBX	43502044h	{CP D}	CPU Marketing Name 5b
ECX	00000053h	{S}	CPU Marketing Name 6a
EDX	00000000h		CPU Marketing Name 6b

**8.2.2.4 CPUID Instruction with EAX = 8000005h**

Extended function 8000005h (EAX = 8000005h) of the CPUID instruction returns information on the internal L1 cache and TLB structures. They are used for reporting purposes only. See Table 8-23 for returned contents.

**8.2.2.5 CPUID Instruction with EAX = 8000006h**

Extended function 8000006h (EAX = 8000006h) of the CPUID instruction returns information on the internal L2 cache and TLB structures. See Table 8-24 on page 632 for returned contents.

**Table 8-23. CPUID Instruction with EAX = 8000005h**

Register	Returned Contents	Description	Comment
EAX	00000000h	4 MB L1 TLB Information	Indicates no 4 MB L1 TLB.
EBX	FF10FF10h	4 KB L1 TLB Information	Decodes to eight fully associative code TLB and eight fully associative data TLB entries.
ECX	40100120h	L1 Data Cache Information	Indicates 16 KB four-way associative with 32-byte lines for data cache. These encodings follow the AMD reporting method.
EDX	40100120h	L1 Code Cache Information	Indicates 16 KB four-way associative with 32-byte lines for code cache. These encodings follow the AMD reporting method.

**Table 8-24. CPUID Instruction with EAX = 8000006h**

Register	Returned Contents	Description	Comment
EAX	0000F004h	L2 TLB Information	Two-way associative 64 entry code and data combined TLB.
EBX	00002040h	L2 TLB Information	
ECX	00804120h	L2 Code Cache Information	Indicates no L2 cache.
EDX	00000000h	L2 Data Cache Information	



## 8.3 Processor Core Instruction Set

The instruction set for the AMD Geode LX processor core is summarized in Table 8-26. The table uses several symbols and abbreviations that are described next and listed in Table 8-25.

### 8.3.1 Opcodes

Opcodes are given as hex values except when they appear within brackets as binary values.

### 8.3.2 Clock Counts

The clock counts listed in the instruction set summary table (Table 8-26) are grouped by operating mode (real and protected) and whether there is a register/cache hit or a cache miss. In some cases, more than one clock count is shown in a column for a given instruction, or a variable is used in the clock count.

### 8.3.3 Flags

There are nine flags that are affected by the execution of instructions. The flag names have been abbreviated and various conventions used to indicate what effect the instruction has on the particular flag.

**Table 8-25. Processor Core Instruction Set Table Legend**

Symbol or Abbreviation	Description
<b>Opcode</b>	
#	Immediate 8-bit data.
##	Immediate 16-bit data.
###	Full immediate 32-bit data (8, 16, or 32 bits).
+	8-bit signed displacement.
+++	Full signed displacement (16 or 32 bits).
<b>Clock Count</b>	
/	Register operand/memory operand.
n	Number of times operation is repeated.
L	Level of the stack frame.
	Conditional jump taken   Conditional jump not taken. (e.g., "4 1" = four clocks if jump taken, one clock if jump not taken).
\	$CPL \leq IOPL \setminus CPL > IOPL$ (where CPL = Current Privilege Level, IOPL = I/O Privilege Level).
<b>Flags</b>	
OF	Overflow Flag.
DF	Direction Flag.
IF	Interrupt Enable Flag.
TF	Trap Flag.
SF	Sign Flag.
ZF	Zero Flag.
AF	Auxiliary Flag.
PF	Parity Flag.
CF	Carry Flag.
x	Flag is modified by the instruction.
-	Flag is not changed by the instruction.
0	Flag is reset to "0."
1	Flag is set to "1."
u	Flag is undefined following execution of the instruction.

Table 8-26. Processor Core Instruction Set

Instruction	Opcode	Clock Count (Reg/Cache Hit)		Flags								Notes		
		Real Mode	Prot'd Mode	O F	D F	I F	T F	S F	Z F	A F	P F	C F	Real Mode	Prot'd Mode
<b>AAA</b> <i>ASCII Adjust AL after Addition</i>	37	3	3	u	-	-	-	u	u	x	u	x		
<b>AAD</b> <i>ASCII Adjust AX before Divide</i>	D5 0A	4	4	u	-	-	-	x	x	u	x	u		
<b>AAM</b> <i>ASCII Adjust AX after Multiply</i> Divide by non-zero Divide by zero	D4 0A	15 18	15 18	u	-	-	-	x	x	u	x	u		
<b>AAS</b> <i>ASCII Adjust AL after Subtract</i>	3F	3	3	u	-	-	-	u	u	x	u	x		
<b>ADC</b> <i>Add with Carry</i> Register to Register Register to Memory Memory to Register Immediate to Register/Memory Immediate to Accumulator	1 [00dw] [11 reg r/m] 1 [000w] [mod reg r/m] 1 [001w] [mod reg r/m] 8 [00sw] [mod 010 r/m]### 1 [010w] ###	1 1 1 1 1	1 1 1 1 1	x	-	-	-	x	x	x	x	x	b	h
<b>ADD</b> <i>Integer Add</i> Register to Register Register to Memory Memory to Register Immediate to Register/Memory Immediate to Accumulator	0 [00dw] [11 reg r/m] 0 [000w] [mod reg r/m] 0 [001w] [mod reg r/m] 8 [00sw] [mod 000 r/m]### 0 [010w] ###	1 1 1 1 1	1 1 1 1 1	x	-	-	-	x	x	x	x	x	b	h
<b>AND</b> <i>Boolean AND</i> Register to Register Register to Memory Memory to Register Immediate to Register/Memory Immediate to Accumulator	2 [00dw] [11 reg r/m] 2 [000w] [mod reg r/m] 2 [001w] [mod reg r/m] 8 [00sw] [mod 100 r/m]### 2 [010w] ###	1 1 1 1 1	1 1 1 1 1	0	-	-	-	x	x	u	x	0	b	h
<b>ARPL</b> <i>Adjust Requested Privilege Level</i> To Memory DST[1:0] < SRC[1:0] To Memory DST[1:0] >= SRC[1:0] To Register DST[1:0] < SRC[1:0] To Register DST[1:0] >= SRC[1:0]	63 [mod reg r/m]		6 4 4 4	-	-	-	-	-	x	-	-	-	a	h
<b>BOUND</b> <i>Check Array Boundaries</i> If Below Range (Interrupt #5) If Above Range (Interrupt #5) If In Range	62 [mod reg r/m]	8+INT 8+INT 6	8+INT 8+INT 6	-	-	-	-	-	-	-	-	-	b, e	g,h,j,k, r
<b>BSF</b> <i>Scan Bit Forward</i> Register, Register/Memory	0F BC [mod reg r/m]	2	2	-	-	-	-	-	x	-	-	-	b	h
<b>BSR</b> <i>Scan Bit Reverse</i> Register, Register/Memory	0F BD [mod reg r/m]	2	2	-	-	-	-	-	x	-	-	-	b	h
<b>BSWAP</b> <i>Byte Swap</i>	0F C[1 reg]	1	1	-	-	-	-	-	-	-	-	-		
<b>BT</b> <i>Test Bit</i> Register/Memory, Immediate Register, Register Memory, Register	0F BA [mod 100 r/m]# 0F A3 [mod reg r/m] 0F A3 [mod reg r/m]	1 1 7	1 1 7	-	-	-	-	-	-	-	-	x	b	h
<b>BTC</b> <i>Test Bit and Complement</i> Register/Memory, Immediate Register, Register Memory, Register	0F BA [mod 111 r/m]# 0F BB [mod reg r/m] 0F BB [mod reg r/m]	2 2 8	2 2 8	-	-	-	-	-	-	-	-	x	b	h
<b>BTR</b> <i>Test Bit and Reset</i> Register/Memory, Immediate Register, register Memory, Register	0F BA [mod 110 r/m]# 0F B3 [mod reg r/m] 0F B3 [mod reg r/m]	2 2 8	2 2 8	-	-	-	-	-	-	-	-	x	b	h

**Table 8-26. Processor Core Instruction Set (Continued)**

Instruction	Opcode	Clock Count (Reg/Cache Hit)		Flags								Notes		
		Real Mode	Prot'd Mode	O	D	I	T	S	Z	A	P	C	Real Mode	Prot'd Mode
<b>BTS</b> <i>Test Bit and Set</i> Register/Memory, Immediate Register, Register Memory, Register	0F BA [mod 101 r/m] # 0F AB [mod reg r/m] 0F AB [mod reg r/m]	2 2 8	2 2 8	-	-	-	-	-	-	-	-	x	b	h
<b>CALL</b> <i>Subroutine Call</i> Direct Within Segment Register/Memory Indirect Within Segment Direct Intersegment -Call Gate -Task Switch Indirect Intersegment -Call Gate -Task Switch	E8 +++ FF [mod 010 r/m] FF [mod 011 r/m]	2 2/4 7 9	2 2/4 11 13	-	-	-	-	-	-	-	-	-	b	h,j,k,r
<b>CBW</b> <i>Convert Byte to Word</i>	98	1	1	-	-	-	-	-	-	-	-	-		
<b>CDQ</b> <i>Convert Doubleword to Quadword</i>	99	1	1	-	-	-	-	-	-	-	-	-		
<b>CLC</b> <i>Clear Carry Flag</i>	F8	1	1	-	-	-	-	-	-	-	0	-		
<b>CLD</b> <i>Clear Direction Flag</i>	FC	2	2	-	0	-	-	-	-	-	-	-		
<b>CLFLUSH</b>		7+	7+											
<b>CLI</b> <i>Clear Interrupt Flag</i>	FA	1	1	-	-	0	-	-	-	-	-	-		m
<b>CLTS</b> <i>Clear Task Switched Flag</i>	0F 06	3	3	-	-	-	-	-	-	-	-	-	c	l
<b>CMC</b> <i>Complement the Carry Flag</i>	F5	2	2	-	-	-	-	-	-	-	x	-		
<b>CMOVA/CMOVNBE</b> <i>Move if Above/Not Below or Equal</i> Register, Register/Memory	0F 47 [mod reg r/m]	1	1	-	-	-	-	-	-	-	-	-		r
<b>CMOVBE/CMOVNA</b> <i>Move if Below or Equal/Not Above</i> Register, Register/Memory	0F 46 [mod reg r/m]	1	1	-	-	-	-	-	-	-	-	-		r
<b>CMOVAE/CMOVNB/CMOVNC</b> <i>Move if Above or Equal/Not Below/Not Carry</i> Register, Register/Memory	0F 43 [mod reg r/m]	1	1	-	-	-	-	-	-	-	-	-		r
<b>CMOVB/CMOVC/CMOVNAE</b> <i>Move if Below/Carry/Not Above or Equal</i> Register, Register/Memory	0F 42 [mod reg r/m]	1	1	-	-	-	-	-	-	-	-	-		r
<b>CMOVE/CMOVZ</b> <i>Move if Equal/Zero</i> Register, Register/Memory	0F 44 [mod reg r/m]	1	1	-	-	-	-	-	-	-	-	-		r
<b>CMOVNE/CMOVNZ</b> <i>Move if Not Equal/Not Zero</i> Register, Register/Memory	0F 45 [mod reg r/m]	1	1	-	-	-	-	-	-	-	-	-		r
<b>CMOVG/CMOVNLE</b> <i>Move if Greater/Not Less or Equal</i> Register, Register/Memory	0F 4F [mod reg r/m]	1	1	-	-	-	-	-	-	-	-	-		r
<b>CMOVLE/CMOVNG</b> <i>Move if Less or Equal/Not Greater</i> Register, Register/Memory	0F 4E [mod reg r/m]	1	1	-	-	-	-	-	-	-	-	-		r
<b>CMOVL/CMOVNGE</b> <i>Move if Less/Not Greater or Equal</i> Register, Register/Memory	0F 4C [mod reg r/m]	1	1	-	-	-	-	-	-	-	-	-		r
<b>CMOVGE/CMOVNLE</b> <i>Move if Greater or Equal/Not Less</i> Register, Register/Memory	0F 4D [mod reg r/m]	1	1	-	-	-	-	-	-	-	-	-		r
<b>CMOVO</b> <i>Move if Overflow</i> Register, Register/Memory	0F 40 [mod reg r/m]	1	1	-	-	-	-	-	-	-	-	-		r
<b>CMOVNO</b> <i>Move if No Overflow</i> Register, Register/Memory	0F 41 [mod reg r/m]	1	1	-	-	-	-	-	-	-	-	-		r
<b>CMOVP/CMOVPE</b> <i>Move if Parity/Parity Even</i> Register, Register/Memory	0F 4A [mod reg r/m]	1	1	-	-	-	-	-	-	-	-	-		r
<b>CMOVNP/CMOVPO</b> <i>Move if Not Parity/Parity Odd</i> Register, Register/Memory	0F 4B [mod reg r/m]	1	1	-	-	-	-	-	-	-	-	-		r
<b>CMOVS</b> <i>Move if Sign</i> Register, Register/Memory	0F 48 [mod reg r/m]	1	1	-	-	-	-	-	-	-	-	-		r

Table 8-26. Processor Core Instruction Set (Continued)

Instruction	Opcode	Clock Count (Reg/Cache Hit)		Flags								Notes		
		Real Mode	Prot'd Mode	O F	D F	I F	T F	S F	Z F	A F	P F	C F	Real Mode	Prot'd Mode
<b>CMOVNS</b> <i>Move if Not Sign</i> Register, Register/Memory	0F 49 [mod reg r/m]	1	1	-	-	-	-	-	-	-	-		r	
<b>CMP</b> <i>Compare Integers</i> Register to Register Register to Memory Memory to Register Immediate to Register/Memory Immediate to Accumulator	3 [10dw] [11 reg r/m] 3 [101w] [mod reg r/m] 3 [100w] [mod reg r/m] 8 [00sw] [mod 111 r/m] ### 3 [110w] ###	1 1 1 1 1	1 1 1 1 1	x	-	-	-	x	x	x	x	x	b	h
<b>CMPS</b> <i>Compare String</i>	A [011w]	6	6	x	-	-	-	x	x	x	x	x	b	h
<b>CMPXCHG</b> <i>Compare and Exchange</i> Register1, Register2 Memory, Register	0F B [000w] [11 reg2 reg1] 0F B [000w] [mod reg r/m]	4 4-5	4 4-5	x	-	-	-	x	x	x	x	x		
<b>CMPXCHG8B</b> <i>Compare and Exchange 8 Bytes</i> If {EDX,EAX} == DST If {EDX,EAX} != DST	0F C7 [mod 001 r/m]	10 12	10 12	-	-	-	-	-	-	-	-	-		
<b>CPUID</b> <i>CPU Identification</i> If EAX <= 1 If 1 < EAX < 2 <sup>31</sup> If 2 <sup>31</sup> <= EAX <= (2 <sup>31</sup> +6) If EAX > (2 <sup>31</sup> +6)	0F A2	13 10 14 11	13 10 14 11	-	-	-	-	-	-	-	-	-		
<b>CWD</b> <i>Convert Word to Doubleword</i>	99	1	1	-	-	-	-	-	-	-	-	-		
<b>CWDE</b> <i>Convert Word to Doubleword Extended</i>	98	3	3	-	-	-	-	-	-	-	-	-		
<b>DAA</b> <i>Decimal Adjust AL after Addition</i>	27	2	2	-	-	-	-	x	x	x	x	x		
<b>DAS</b> <i>Decimal Adjust AL after Subtraction</i>	2F	2	2	-	-	-	-	x	x	x	x	x		
<b>DEC</b> <i>Decrement by 1</i> Register/Memory Byte Register/Memory Word/DWord Register (short form)	FE [mod 001 r/m] FF [mod 001 r/m] 4 [1 reg]	1 1 1	1 1 1	x	-	-	-	x	x	x	x	-	b	h
<b>DIV</b> <i>Unsigned Divide</i> Accumulator by Register/Memory Divisor: Byte Word Doubleword	F [011w] [mod 110 r/m]	15 23 7-39	15 23 7-39	-	-	-	-	x	x	u	u	-	b,e	e,h
<b>DMINT</b> <i>Enter Debug Management Mode</i>	0F 39	48-50	50-52	0	0	0	0	0	0	0	0	0	s, u	s, u
<b>ENTER</b> <i>Enter New Stack Frame</i> Level = 0 Level = 1 Level (L) > 1	C8 ##, #	7 13 15+21	7 13 15+21	-	-	-	-	-	-	-	-	-	b	h
<b>HLT</b> <i>Halt</i>	F4	13+	13+	-	-	-	-	-	-	-	-	-		l
<b>ICEBP</b> <i>Call Debug Exception Handler</i>	F1	29+	29+	-	-	x	0	-	-	-	-	-	u	u
<b>IDIV</b> <i>Integer (Signed) Divide</i> Accumulator by Register/Memory Divisor: Byte Word Doubleword	F [011w] [mod 111 r/m]	16 24 40	16 24 7-40	-	-	-	-	x	x	u	u	-	b,e	e,h

**Table 8-26. Processor Core Instruction Set (Continued)**

Instruction	Opcode	Clock Count (Reg/Cache Hit)		Flags								Notes		
		Real Mode	Prot'd Mode	O	D	I	T	S	Z	A	P	C	Real Mode	Prot'd Mode
				F	F	F	F	F	F	F	F			
<b>IMUL</b> <i>Integer (Signed) Multiply</i> Accumulator by Register/Memory Multiplier: Byte Word Doubleword Register with Register/Memory Multiplier: Word Doubleword Register/Memory with Immediate to Register2 Multiplier: Byte Word Doubleword	F [011w] [mod 101 r/m]  0F AF [mod reg r/m]  6 [10s1] [mod reg r/m] ###	 3 4 4  4 4  4-6 4-7 4-7	 3 4 4  4 4  4-6 4-7 4-7	 x    x   x   x   x   x   x	-	-	-	-	-	-	-	b	h	
<b>IN</b> <i>Input from I/O Port</i> Fixed Port Variable Port	E [010w] # E [110w]	7 7	7/21 7/21	-	-	-	-	-	-	-	-		m	
<b>INC</b> <i>Increment by 1</i> Register/Memory Register (short form)	F [111w] [mod 000 r/m] 4 [0 reg]	1 1	1 1	x	-	-	-	x	x	x	x	-	b	h
<b>INS</b> <i>Input String from I/O Port</i>	6 [110w]	10	10/24	-	-	-	-	-	-	-	-	b	h,m	
<b>INT i</b> <i>Software Interrupt</i>	CD #	23	37-245	-	-	x	0	-	-	-	-	b,e	g,j,k,r	
<b>INT 3</b> <i>Breakpoint Software Interrupt</i>	CC	21-22	37-245									b,c	g,i,k,r	
<b>INTO</b> <i>Overflow Software Interrupt</i> If OF==0 If OF==1 (INT 4)	CE	4 7	4 7									b,c	g,i,k,r	
<b>INVD</b> <i>Invalidate Cache</i>	0F 08	9+	9+	-	-	-	-	-	-	-	-	t	t	
<b>INVLPG</b> <i>Invalidate TLB Entry</i>	0F 01 [mod 111 r/m]	7+	7+	-	-	-	-	-	-	-	-			
<b>IRET</b> <i>Interrupt Return</i>	CF	6-13	13-239	x	x	x	x	x	x	x	x		g,h,j,k,r	
<b>JB/JNAE/JC</b> <i>Jump on Below/Not Above or Equal/Carry</i> 8-bit Displacement Full Displacement	72 + 0F 82 +++	1 1	1 1	-	-	-	-	-	-	-	-		r	
<b>JBE/JNA</b> <i>Jump on Below or Equal/Not Above</i> 8-bit Displacement Full Displacement	76 + 0F 86 +++	1 1	1 1	-	-	-	-	-	-	-	-		r	
<b>JCXZ/JECXZ</b> <i>Jump on CX/ECX Zero</i>	E3 +	2	2	-	-	-	-	-	-	-	-		r	
<b>JE/JZ</b> <i>Jump on Equal/Zero</i> 8-bit Displacement Full Displacement	74 + 0F 84 +++	1 1	1 1	-	-	-	-	-	-	-	-		r	
<b>JL/JNGE</b> <i>Jump on Less/Not Greater or Equal</i> 8-bit Displacement Full Displacement	7C + 0F 8C +++	1 1	1 1	-	-	-	-	-	-	-	-		r	
<b>JLE/JNG</b> <i>Jump on Less or Equal/Not Greater</i> 8-bit Displacement Full Displacement	7E + 0F 8E +++	1 1	1 1	-	-	-	-	-	-	-	-		r	
<b>JMP</b> <i>Unconditional Jump</i> 8-bit Displacement Full Displacement Register/Memory Indirect Within Segment Direct Intersegment Indirect Intersegment	EB + E9 +++ FF [mod 100 r/m] EA [unsigned full offset, selector] FF [mod 101 r/m]	1 1 1/3 7 9	1 1 1/3 9-254 11-256	-	-	-	-	-	-	-	-	b	h,j,k,r	
<b>JNB/JAE/JNC</b> <i>Jump on Not Below/Above or Equal/Not Carry</i> 8-bit Displacement Full Displacement	73 + 0F 83 +++	1 1	1 1	-	-	-	-	-	-	-	-		r	

**Table 8-26. Processor Core Instruction Set (Continued)**

Instruction	Opcode	Clock Count (Reg/Cache Hit)		Flags								Notes	
		Real Mode	Prot'd Mode	O F	D F	I F	T F	S F	Z F	A F	P F	C F	Real Mode
<b>JNBE/JA</b> <i>Jump on Not Below or Equal/Above</i> 8-bit Displacement Full Displacement	77 + 0F 87 +++	1 1	1 1	-	-	-	-	-	-	-	-		r
<b>JNE/JNZ</b> <i>Jump on Not Equal/Not Zero</i> 8-bit Displacement Full Displacement	75 + 0F 85 +++	1 1	1 1	-	-	-	-	-	-	-	-		r
<b>JNL/JGE</b> <i>Jump on Not Less/Greater or Equal</i> 8-bit Displacement Full Displacement	7D + 0F 8D +++	1 1	1 1	-	-	-	-	-	-	-	-		r
<b>JNLE/JG</b> <i>Jump on Not Less or Equal/Greater</i> 8-bit Displacement Full Displacement	7F + 0F 8F +++	1 1	1 1	-	-	-	-	-	-	-	-		r
<b>JNO</b> <i>Jump on Not Overflow</i> 8-bit Displacement Full Displacement	71 + 0F 81 +++	1 1	1 1	-	-	-	-	-	-	-	-		r
<b>JNP/JPO</b> <i>Jump on Not Parity/Parity Odd</i> 8-bit Displacement Full Displacement	7B + 0F 8B +++	1 1	1 1	-	-	-	-	-	-	-	-		r
<b>JNS</b> <i>Jump on Not Sign</i> 8-bit Displacement Full Displacement	79 + 0F 89 +++	1 1	1 1	-	-	-	-	-	-	-	-		r
<b>JO</b> <i>Jump on Overflow</i> 8-bit Displacement Full Displacement	70 + 0F 80 +++	1 1	1 1	-	-	-	-	-	-	-	-		r
<b>JP/JPE</b> <i>Jump on Parity/Parity Even</i> 8-bit Displacement Full Displacement	7A + 0F 8A +++	1 1	1 1	-	-	-	-	-	-	-	-		r
<b>JS</b> <i>Jump on Sign</i> 8-bit Displacement Full Displacement	78 + 0F 88 +++	1 1	1 1	-	-	-	-	-	-	-	-		r
<b>LAHF</b> <i>Load AH with Flags</i>	9F	2	2	-	-	-	-	-	-	-	-		
<b>LAR</b> <i>Load Access Rights</i> From Register/Memory	0F 02 [mod reg r/m]		9	-	-	-	-	x	-	-	-	a	g,h,j,p
<b>LDS</b> <i>Load Pointer to DS</i>	C5 [mod reg r/m]	4	9/15	-	-	-	-	-	-	-	-	b	h,i,j
<b>LEA</b> <i>Load Effective Address</i> No Index Register With Index Register	8D [mod reg r/m]	1 1	1 1	-	-	-	-	-	-	-	-		
<b>LEAVE</b>		2	2										
<b>LES</b> <i>Load Pointer to ES</i>	C4 [mod reg r/m]	4	9/15	-	-	-	-	-	-	-	-	b	h,i,j
<b>LFENCE</b>		1	1										
<b>LFS</b> <i>Load Pointer to FS</i>	0F B4 [mod reg r/m]	4	9/15	-	-	-	-	-	-	-	-	b	h,i,j
<b>LGDT</b> <i>Load GDT Register</i>	0F 01 [mod 010 r/m]	8-9	8-9	-	-	-	-	-	-	-	-	b,c	h,l
<b>LGS</b> <i>Load Pointer to GS</i>	0F B5 [mod reg r/m]	4	9/15	-	-	-	-	-	-	-	-	b	h,i,j
<b>LIDT</b> <i>Load IDT Register</i>	0F 01 [mod 011 r/m]	8-9	8-9	-	-	-	-	-	-	-	-	b,c	h,l
<b>LLDT</b> <i>Load LDT Register</i> From Register/Memory	0F 00 [mod 010 r/m]		8	-	-	-	-	-	-	-	-	a	g,h,j,l
<b>LMSW</b> <i>Load Machine Status Word</i> From Register/Memory	0F 01 [mod 110 r/m]	8	8	-	-	-	-	-	-	-	-	b,c	h,l
<b>LODS</b> <i>Load String</i>	A [110 w]	2	2	-	-	-	-	-	-	-	-	b	h
<b>LOOP</b> <i>Offset Loop/No Loop</i>	E2 +	2	2	-	-	-	-	-	-	-	-		r

**Table 8-26. Processor Core Instruction Set (Continued)**

Instruction	Opcode	Clock Count (Reg/Cache Hit)		Flags								Notes		
		Real Mode	Prot'd Mode	O F	D F	I F	T F	S F	Z F	A F	P F	C F	Real Mode	Prot'd Mode
<b>LOOPNZ/LOOPNE</b> <i>Offset</i>	E0 +	2	2	-	-	-	-	-	-	-	-		r	
<b>LOOPZ/LOOPE</b> <i>Offset</i>	E1 +	2	2	-	-	-	-	-	-	-	-	r		
<b>LSL</b> <i>Load Segment Limit</i> From Register/Memory	0F 03 [mod reg r/m]		9	-	-	-	-	-	x	-	-	a	g,h,j,p	
<b>LSS</b> <i>Load Pointer to SS</i>	0F B2 [mod reg r/m]	4	9/15	-	-	-	-	-	-	-	-	a	h,i,j	
<b>LTR</b> <i>Load Task Register</i> From Register/Memory	0F 00 [mod 011 r/m]		9	-	-	-	-	-	-	-	-	a	g,h,j,l	
<b>LEAVE</b> <i>Leave Current Stack Frame</i>	C9	2	2	-	-	-	-	-	-	-	-	b	h	
<b>MFENCE</b>			1											
<b>MOV</b> <i>Move Data</i> Register to Register	8 [10dw] [11 reg r/m]	1	1	-	-	-	-	-	-	-	-	b	h	
Register to Memory	8 [100w] [mod reg r/m]	1	1											
Register/Memory to Register	8 [101w] [mod reg r/m]	1	1											
Immediate to Register/Memory	C [011w] [mod 000 r/m] ###	1	1											
Immediate to Register (short form)	B [w reg] ###	1	1											
Memory to Accumulator (short form)	A [000w] +++	1	1											
Accumulator to Memory (short form)	A [001w] +++	1	1											
<b>MOV</b> <i>Move to/from Segment Registers</i> To Stack Segment			7/13	-	-	-	-	-	-	-	-		i,j	
To all other segments: Register/Memory to Segment Register	8E [mod sreg3 r/m]	1	6/13											
Segment Register to Register/Memory	8C [mod sreg3 r/m]	1	6/13											
<b>MOV</b> <i>Move to/from Control Registers</i> Register to CR	0F 22 [11 eee reg]	9-13	9-13	-	-	-	-	-	-	-	-		l	
CR to Register	0F 20 [11 eee reg]	2-5	2-5											
<b>MOV</b> <i>Move To/From Debug Registers</i> Register to DR	0F 23 [11 eee reg]	10/18	10/18	-	-	-	-	-	-	-	-		l	
DR to Register	0F 21 [11 eee reg]	8/18	8/18											
<b>MOV</b> <i>Move To/From Test Registers</i> Register to TR	0F 26 [11 eee reg]	2	2	-	-	-	-	-	-	-	-	u	l,u	
TR to Register	0F 24 [11 eee reg]	1	1											
<b>MOVS</b> <i>Move String</i>	A [010w]	4	4	-	-	-	-	-	-	-	-	b	h	
<b>MOVSX</b> <i>Move with Sign Extension</i> Register from Register/Memory	0F B[111w] [mod reg r/m]	1	1	-	-	-	-	-	-	-	-	b	h	
<b>MOVZX</b> <i>Move with Zero Extension</i> Register from Register/Memory	0F B[011w] [mod reg r/m]	1	1	-	-	-	-	-	-	-	-	b	h	
<b>MUL</b> <i>Unsigned Multiply</i> Accumulator with Register/Memory	F [011w] [mod 100 r/m]			x	-	-	-	x	x	u	u	x	b	h
Multiplier: Byte		3	3											
Word		4	4											
Doubleword		7	7											
<b>NEG</b> <i>Negate Integer</i>	F [011w] [mod 011 r/m]	1	1	x	-	-	-	x	x	x	x	x	b	h
<b>NOP</b> <i>No Operation</i>	90	1	1	-	-	-	-	-	-	-	-			
<b>NOT</b> <i>Boolean Complement</i>	F [011w] [mod 010 r/m]	1	1	-	-	-	-	-	-	-	-	b	h	
<b>OIO</b> <i>Official Invalid Opcode</i>	0F FF	1	8-125	-	-	x	0	-	-	-	-			
<b>OR</b> <i>Boolean OR</i> Register to Register	0 [10dw] [11 reg r/m]	1	1	0	-	-	-	x	x	u	x	0	b	h
Register to Memory	0 [100w] [mod reg r/m]	1	1											
Memory to Register	0 [101w] [mod reg r/m]	1	1											
Immediate to Register/Memory	8 [00sw] [mod 001 r/m] ###	1	1											
Immediate to Accumulator	0 [110w] ###	1	1											

**Table 8-26. Processor Core Instruction Set (Continued)**

Instruction	Opcode	Clock Count (Reg/Cache Hit)		Flags								Notes		
		Real Mode	Prot'd Mode	O	D	I	T	S	Z	A	P	C	Real Mode	Prot'd Mode
				F	F	F	F	F	F	F	F			
<b>OUT</b> <i>Output to Port</i> Fixed Port Variable Port	E [011w] # E [111w]	8 8	8/23 8/23	-	-	-	-	-	-	-	-		m	
<b>OUTS</b> <i>Output String</i>	6 [111w]	12	12/26	-	-	-	-	-	-	-	-	b	h,m	
<b>PAUSE</b>			7											
<b>POP</b> <i>Pop Value off Stack</i> Register Memory Register (short form) DS ES SS FS GS	8F [mod 000 r/m] 8F [mod 000 r/m] 5 [1 reg] 1F 07 17 0F A1 0F 9A	1 3 1 1 1 1 1 1	1 3 1 6/13 6/13 7/13 6/13 6/13	-	-	-	-	-	-	-	-	b	h,i,j	
<b>POPA</b> <i>Pop All General Registers</i>	61	8	8	-	-	-	-	-	-	-	-	b	h	
<b>POPF</b> <i>Pop Stack into FLAGS</i>	9D	2	2	x	x	x	x	x	x	x	x	b	h,n	
<b>PREFIX BYTES</b> Assert Hardware LOCK Prefix Address Size Prefix Operand Size Prefix Segment Override Prefix -CS -DS -ES -FS -GS -SS	F0 67 66 2E 3E 26 64 65 36			-	-	-	-	-	-	-	-		m	
<b>PUSH</b> <i>Push Value onto Stack</i> Register/Memory Register (short form) CS SS DS ES FS GS Immediate	FF [mod 110 r/m] 5 [0 reg] 0E 16 1E 06 0F A0 0F A8 6 [10s0] ###	1/2 1 1 1 1 1 1 1 1	1/2 1 1 1 1 1 1 1 1	-	-	-	-	-	-	-	-	b	h	
<b>PUSHA</b> <i>Push All General Registers</i>	60	8	8	-	-	-	-	-	-	-	-	b	h	
<b>PUSHF</b> <i>Push FLAGS Register</i>	9C	2	2	-	-	-	-	-	-	-	-	b	h	
<b>RCL</b> <i>Rotate Through Carry Left</i> Register/Memory by 1 Register/Memory by CL Register/Memory by Immediate	D [000w] [mod 010 r/m] D [001w] [mod 010 r/m] C [000w] [mod 010 r/m] #	2 4-6 4-6	2 4-6 4-6	x	-	-	-	-	-	-	-	x	b	h
<b>RCR</b> <i>Rotate Through Carry Right</i> Register/Memory by 1 Register/Memory by CL Register/Memory by Immediate	D [000w] [mod 011 r/m] D [001w] [mod 011 r/m] C [000w] [mod 011 r/m] #	3-5 4-7 4-7	3-4 4-7 4-7	x	-	-	-	-	-	-	-	x	b	h
<b>RDM</b> <i>Leave Debug Management Mode</i>	0F 3A	36+	36+	x	x	x	x	x	x	x	x	s, u	s, u	
<b>RDMSR</b> <i>Read Tmodel Specific Register (Note 1)</i>	0F 32	5	5	-	-	-	-	-	-	-	-			
<b>RDPMC</b> (Note 1)		7	7											
<b>RDTSR</b> <i>Read Time Stamp Counter (Note 1)</i>	0F 31	5	5	-	-	-	-	-	-	-	-			



**Table 8-26. Processor Core Instruction Set (Continued)**

Instruction	Opcode	Clock Count (Reg/Cache Hit)		Flags								Notes	
		Real Mode	Prot'd Mode	O	D	I	T	S	Z	A	P	C	Real Mode
<b>REP CMPS</b> CX==0 CX==1 CX>1		6 13 10+3C	6 13 10+3C										
<b>REP INS</b> <i>Input String</i> CX==0 CX==1 CX>1	F3 6[110w]	9  15+6C	9/24  15+6C/ 30+6C	-	-	-	-	-	-	-	-	b	h,m
<b>REP LODS</b> <i>Load String</i> CX==0 CX==1 CX>1	F3 A[110w]	5 10 8+2C	5 10 8+2C	-	-	-	-	-	-	-	-	b	h
<b>REP MOVS</b> <i>Move String</i> CX==0 CX==1 CX>1	F3 A[010w]	5 13 11+2C	5 13 11+2C	-	-	-	-	-	-	-	-	b	h
<b>REP OUTS</b> <i>Output String</i>	F3 6[111w]	16+10 C	16+10 C 31+10 C	-	-	-	-	-	-	-	-	b	h,m
<b>REP STOS</b> <i>Store String</i>	F3 A[101w]	8+c	8+c	-	-	-	-	-	-	-	-	b	h
<b>REPE CMPS</b> <i>Compare String</i> Find non-match	F3 A[011w]	11+4n	11+4n	x	-	-	-	x	x	x	x	b	h
<b>REPE SCAS</b> <i>Scan String</i> Find non-AL/AX/EAX	F3 A[111w]	7+2n	7+2n	x	-	-	-	x	x	x	x	b	h
<b>REPNE CMPS</b> <i>Compare String</i> Find match	F2 A[011w]	10+4n	10+4n	x	-	-	-	x	x	x	x	b	h
<b>REPNE SCAS</b> <i>Scan String</i> Find AL/AX/EAX	F2 A[111w]	7+3n	7+3n	x	-	-	-	x	x	x	x	b	h
<b>RET</b> <i>Return from Subroutine</i> Within Segment Within Segment Adding Immediate to SP Intersegment Intersegment Adding Immediate to SP Protected Mode: Different Privilege Level -Intersegment -Intersegment Adding Immediate to SP	C3 C2 ## CB CA ##	3 3 6 7	3 3 10-48 10-48									b	g,h,j,k, r
<b>ROL</b> <i>Rotate Left</i> Register/Memory by 1 Register/Memory by CL Register/Memory by Immediate	D[000w] [mod 000 r/m] D[001w] [mod 000 r/m] C[000w] [mod 000 r/m] #	2 2 2	2 2 2	x	-	-	-	-	-	-	-	b	h
<b>ROR</b> <i>Rotate Right</i> Register/Memory by 1 Register/Memory by CL Register/Memory by Immediate	D[000w] [mod 001 r/m] D[001w] [mod 001 r/m] C[000w] [mod 001 r/m] #	2 2 2	2 2 2	x	-	-	-	-	-	-	-	b	h
<b>RSDC</b> <i>Restore Segment Register and Descriptor</i>	0F 79 [mod sreg3 r/m]	9	9	-	-	-	-	-	-	-	-	s,u	s,u
<b>RSLDT</b> <i>Restore LDTR and Descriptor</i>	0F 7B [mod 000 r/m]	9	9	-	-	-	-	-	-	-	-	s,u	s,u
<b>RSTS</b> <i>Restore TSR and Descriptor</i>	0F 7D [mod 000 r/m]	10	10	-	-	-	-	-	-	-	-	s,u	s,u
<b>RSM</b> <i>Resume from SMM Mode</i>	0F AA	35	35	x	x	x	x	x	x	x	x	s,u	s,u
<b>SAHF</b> <i>Store AH in FLAGS</i>	9E	1	1	-	-	-	-	x	x	x	x		

**Table 8-26. Processor Core Instruction Set (Continued)**

Instruction	Opcode	Clock Count (Reg/Cache Hit)		Flags								Notes	
		Real Mode	Prot'd Mode	O F	D F	I F	T F	S F	Z F	A F	P F	C F	Real Mode
<b>SAL</b> <i>Shift Left Arithmetic</i> Register/Memory by 1 Register/Memory by CL Register/Memory by Immediate	D[000w] [mod 100 r/m] D[001w] [mod 100 r/m] C[000w] [mod 100 r/m] #	1 1 1	1 1 1	x u u	- - -	- - -	- - -	x x x	x x x	u u u	x x x	b	h
<b>SAR</b> <i>Shift Right Arithmetic</i> Register/Memory by 1 Register/Memory by CL Register/Memory by Immediate	D[000w] [mod 111 r/m] D[001w] [mod 111 r/m] C[000w] [mod 111 r/m] #	2 2 2	2 2 2	x u u	- - -	- - -	- - -	x x x	x x x	u u u	x x x	b	h
<b>SBB</b> <i>Integer Subtract with Borrow</i> Register to Register Register to Memory Memory to Register Immediate to Register/Memory Immediate to Accumulator (short form)	1[10dw] [11 reg r/m] 1[100w] [mod reg r/m] 1[101w] [mod reg r/m] 8[00sw] [mod 011 r/m] ### 1[110w] ###	1 1 1 1 1	1 1 1 1 1	x	-	-	-	x	x	x	x	x	h
<b>SCAS</b> <i>Scan String</i>	A [111w]	2	2	x	-	-	-	x	x	x	x	b	h
<b>SETALC</b> <i>Set AL to CF</i>	D6	2	2									u	u
<b>SETB/SETNAE/SETC</b> <i>Set Byte on Below/Not Above or Equal/Carry</i> To Register/Memory	0F 92 [mod 000 r/m]	1	1	-	-	-	-	-	-	-	-		h
<b>SETBE/SETNA</b> <i>Set Byte on Below or Equal/Not Above</i> To Register/Memory	0F 96 [mod 000 r/m]	1	1	-	-	-	-	-	-	-	-		h
<b>SETE/SETZ</b> <i>Set Byte on Equal/Zero</i> To Register/Memory	0F 94 [mod 000 r/m]	1	1	-	-	-	-	-	-	-	-		h
<b>SETL/SETNGE</b> <i>Set Byte on Less/Not Greater or Equal</i> To Register/Memory	0F 9C [mod 000 r/m]	1	1	-	-	-	-	-	-	-	-		h
<b>SETLE/SETNG</b> <i>Set Byte on Less or Equal/Not Greater</i> To Register/Memory	0F 9E [mod 000 r/m]	1	1	-	-	-	-	-	-	-	-		h
<b>SETNB/SETAE/SETNC</b> <i>Set Byte on Not Below/Above or Equal/Not Carry</i> To Register/Memory	0F 93 [mod 000 r/m]	1	1	-	-	-	-	-	-	-	-		h
<b>SETNBE/SETA</b> <i>Set Byte on Not Below or Equal/Above</i> To Register/Memory	0F 97 [mod 000 r/m]	1	1	-	-	-	-	-	-	-	-		h
<b>SETNE/SETNZ</b> <i>Set Byte on Not Equal/Not Zero</i> To Register/Memory	0F 95 [mod 000 r/m]	1	1	-	-	-	-	-	-	-	-		h
<b>SETNL/SETGE</b> <i>Set Byte on Not Less/Greater or Equal</i> To Register/Memory	0F 9D [mod 000 r/m]	1	1	-	-	-	-	-	-	-	-		h
<b>SETNLE/SETG</b> <i>Set Byte on Not Less or Equal/Greater</i> To Register/Memory	0F 9F [mod 000 r/m]	1	1	-	-	-	-	-	-	-	-		h
<b>SETNO</b> <i>Set Byte on Not Overflow</i> To Register/Memory	0F 91 [mod 000 r/m]	1	1	-	-	-	-	-	-	-	-		h
<b>SETNP/SETPO</b> <i>Set Byte on Not Parity/Parity Odd</i> To Register/Memory	0F 9B [mod 000 r/m]	1	1	-	-	-	-	-	-	-	-		h
<b>SETNS</b> <i>Set Byte on Not Sign</i> To Register/Memory	0F 99 [mod 000 r/m]	1	1	-	-	-	-	-	-	-	-		h
<b>SETO</b> <i>Set Byte on Overflow</i> To Register/Memory	0F 90 [mod 000 r/m]	1	1	-	-	-	-	-	-	-	-		h
<b>SETP/SETPE</b> <i>Set Byte on Parity/Parity Even</i> To Register/Memory	0F 9A [mod 000 r/m]	1	1	-	-	-	-	-	-	-	-		h
<b>SETS</b> <i>Set Byte on Sign</i> To Register/Memory	0F 98 [mod 000 r/m]	1	1	-	-	-	-	-	-	-	-		h

**Table 8-26. Processor Core Instruction Set (Continued)**

Instruction	Opcode	Clock Count (Reg/Cache Hit)		Flags								Notes		
		Real Mode	Prot'd Mode	O F	D F	I F	T F	S F	Z F	A F	P F	C F	Real Mode	Prot'd Mode
<b>SFENCE</b>		1	1											
<b>SGDT</b> <i>Store GDT Register</i> To Register/Memory	0F 01 [mod 000 r/m]	6	6	-	-	-	-	-	-	-	-	b,c	h	
<b>SIDT</b> <i>Store IDT Register</i> To Register/Memory	0F 01 [mod 001 r/m]	6	6	-	-	-	-	-	-	-	-	b,c	h	
<b>SLDT</b> <i>Store LDT Register</i> To Register/Memory	0F 00 [mod 000 r/m]		1	-	-	-	-	-	-	-	-	a	h	
<b>STR</b> <i>Store Task Register</i> To Register/Memory	0F 00 [mod 001 r/m]		3	-	-	-	-	-	-	-	-	a	h	
<b>SMSW</b> <i>Store Machine Status Word</i>	0F 01 [mod 100 r/m]	2	2	-	-	-	-	-	-	-	-	b,c	h	
<b>STOS</b> <i>Store String</i>	A [101w]	2	2	-	-	-	-	-	-	-	-	b	h	
<b>SHL</b> <i>Shift Left Logical</i> Register/Memory by 1	D [000w] [mod 100 r/m]	1	1	x	-	-	-	x	x	u	x	x	b	h
Register/Memory by CL	D [001w] [mod 100 r/m]	2	2	u	-	-	-	x	x	u	x	x		
Register/Memory by Immediate	C [000w] [mod 100 r/m] #	1	1	u	-	-	-	x	x	u	x	x		
<b>SHLD</b> <i>Shift Left Double</i> Register/Memory by Immediate	0F A4 [mod reg r/m] #	2	1	u	-	-	-	x	x	u	x	x	b	h
Register/Memory by CL	0F A5 [mod reg r/m]	2	1											
<b>SHR</b> <i>Shift Right Logical</i> Register/Memory by 1	D [000w] [mod 101 r/m]	2	1	x	-	-	-	x	x	u	x	x	b	h
Register/Memory by CL	D [001w] [mod 101 r/m]	2	1	u	-	-	-	x	x	u	x	x		
Register/Memory by Immediate	C [000w] [mod 101 r/m] #	2	1	u	-	-	-	x	x	u	x	x		
<b>SHRD</b> <i>Shift Right Double</i> Register/Memory by Immediate	0F AC [mod reg r/m] #	2	1	u	-	-	-	x	x	u	x	x	b	h
Register/Memory by CL	0F AD [mod reg r/m]	2	1											
<b>SMINT</b> <i>Software SMM Entry</i>	0F 38	56-58	56-58	0	0	0	0	0	0	0	0	s,u	s,u	
<b>STC</b> <i>Set Carry Flag</i>	F9	1	1	-	-	-	-	-	-	-	1			
<b>STD</b> <i>Set Direction Flag</i>	FD	2	2	-	1	-	-	-	-	-	-			
<b>STI</b> <i>Set Interrupt Flag</i>	FB	1	1	-	-	1	-	-	-	-	-		m	
<b>SUB</b> <i>Integer Subtract</i> Register to Register	2 [10dw] [11 reg r/m]	1	1	x	-	-	-	x	x	x	x	b	h	
Register to Memory	2 [100w] [mod reg r/m]	1	1											
Memory to Register	2 [101w] [mod reg r/m]	1	1											
Immediate to Register/Memory	8 [00sw] [mod 101 r/m] ###	1	1											
Immediate to Accumulator (short form)	2 [110w] ###	1	1											
<b>SVDC</b> <i>Save Segment Register and Descriptor</i>	0F 78 [mod sreg3 r/m]	7	7	-	-	-	-	-	-	-	-	s,u	s,u	
<b>SVLDT</b> <i>Save LDTR and Descriptor</i>	0F 7A [mod 000 r/m]	7	7	-	-	-	-	-	-	-	-	s,u	s,u	
<b>SVTS</b> <i>Save TSR and Descriptor</i>	0F 7C [mod 000 r/m]	8	8	-	-	-	-	-	-	-	-	s,u	s,u	
<b>SYSENTER</b> <i>Fast System Call Entry</i>	0F 34	10	10	-	-	-	-	-	-	-	-			
<b>SYSEXIT</b> <i>Fast System Call Exit</i>	0F 35	11	11	-	-	-	-	-	-	-	-			
<b>TEST</b> <i>Test Bits</i> Register/Memory and Register	8 [010w] [mod reg r/m]	1	1	0	-	-	-	x	x	u	x	0	b	h
Immediate Data and Register/Memory	F [011w] [mod 000 r/m] ###	1	1											
Immediate Data and Accumulator	A [100w] ###	1	1											
<b>VERR</b> <i>Verify Read Access</i> To Register/Memory	0F 00 [mod 100 r/m]		8	-	-	-	-	-	x	-	-	a	g,h,j,p	
<b>VERW</b> <i>Verify Write Access</i> To Register/Memory	0F 00 [mod 101 r/m]		8	-	-	-	-	-	x	-	-	a	g,h,j,p	
<b>WAIT</b> <i>Wait Until FPU Not Busy</i>	9B	1	1	-	-	-	-	-	-	-	-			
<b>WBINVD</b> <i>Writeback and Invalidate Cache</i>	0F 09	16+	16+	-	-	-	-	-	-	-	-	t	t	

**Table 8-26. Processor Core Instruction Set (Continued)**

Instruction	Opcode	Clock Count (Reg/Cache Hit)		Flags								Notes		
		Real Mode	Prot'd Mode	O F	D F	I F	T F	S F	Z F	A F	P F	C F	Real Mode	Prot'd Mode
<b>WRMSR</b> <i>Write to Model Specific Register</i>	0F 30	10	10	-	-	-	-	-	-	-	-	-	-	-
<b>XADD</b> <i>Exchange and Add</i> Register1, Register2 Memory, Register	0F C[000w] [11 reg2 reg1] 0F C[000w] [mod reg r/m]	2 2	2 2	x	-	-	-	x	x	x	x	x	x	x
<b>XCHG</b> <i>Exchange</i> Register/Memory with Register Register with Accumulator	8[011w] [mod reg r/m] 9[0 reg]	2 2	2 2	-	-	-	-	-	-	-	-	-	b,f	f,h
<b>XLAT</b> <i>Translate Byte</i>	D7	4	4	-	-	-	-	-	-	-	-	-	-	h
<b>XOR</b> <i>Boolean Exclusive OR</i> Register to Register Register to Memory Memory to Register Immediate to Register/Memory Immediate to Accumulator (short form)	3 [00dw] [11 reg r/m] 3 [000w] [mod reg r/m] 3 [001w] [mod reg r/m] 8 [00sw] [mod 110 r/m] ### 3 [010w] ###	1 1 1 1 1	1 1 1 1 1	0	-	-	-	x	x	u	x	0	b	h

Note 1. The instructions, RDTSC, RDPMC, and RDMSR all have the effect of serializing with pending memory requests. For example, a RDTSC will not complete until any pending line fills or prefetches have completed. This is an artifact of the AMD Geode CPU and GeodeLink architecture since out-of-order read responses are not supported.

**Instruction Notes for Instruction Set Summary**

Notes a through c apply to real address mode only:

- a. This is a protected mode instruction. Attempted execution in real mode results in exception 6 (invalid opcode).
- b. Exception 13 fault (general protection) occurs in real mode if an operand reference is made that partially or fully extends beyond the maximum CS, DS, ES, FS, or GS segment limit. Exception 12 fault (stack segment limit violation or not present) occurs in real mode if an operand reference is made that partially or fully extends beyond the maximum SS limit.
- c. This instruction may be executed in real mode. In real mode, its purpose is primarily to initialize the CPU for protected mode.

Notes e through g apply to real address mode and protected virtual address mode:

- e. An exception may occur, depending on the value of the operand.
- f. LOCK# is automatically asserted, regardless of the presence or absence of the LOCK prefix.
- g. LOCK# is asserted during descriptor table accesses.

Notes h through r apply to protected virtual address mode only:

- h. Exception 13 fault occurs if the memory operand in CS, DS, ES, FS, or GS cannot be used due to either a segment limit violation or an access rights violation. If a stack limit is violated, an exception 12 occurs.
- i. For segment load operations, the CPL, RPL, and DPL must agree with the privilege rules to avoid an exception 13 fault. The segment's descriptor must indicate "present" or exception 11 (CS, DS, ES, FS, or GS not present). If the SS register is loaded, and a stack segment not present is detected, an exception 12 occurs.
- j. All segment descriptor accesses in the GDT or LDT made by this instruction automatically assert LOCK# to maintain descriptor integrity in multiprocessor systems.
- k. JMP, CALL, INT, RET, and IRET instructions referring to another code segment cause an exception 13, if an applicable privilege rule is violated.
- l. An exception 13 fault occurs if CPL is greater than 0 (0 is the most privileged level).
- m. An exception 13 fault occurs if CPL is greater than IOPL.
- n. The IF bit of the Flags register is not updated if CPL is greater than IOPL. The IOPL and VM fields of the Flags register are updated only if CPL = 0.
- o. The PE bit of the MSW (CR0) cannot be reset by this instruction. Use MOV into CR0 if you need to reset the PE bit.
- p. Any violation of privilege rules as they apply to the selector operand do not cause a Protection exception; rather, the zero flag is cleared.
- q. If the processor's memory operand violates a segment limit or segment access rights, an exception 13 fault occurs before the ESC instruction is executed. An exception 12 fault occurs if the stack limit is violated by the operand's starting address.
- r. The destination of a JMP, CALL, INT, RET, or IRET must be in the defined limit of a code segment or an exception 13 fault occurs.

Issue s applies to AMD-specific SMM and DMM instructions:

- s. An invalid opcode exception 6 occurs unless the current privilege level is zero (most privileged) and either the instruction is enabled in SMM\_CTL, the instruction is enabled in DMM\_CTL, the processor is in system management mode, or the processor is in debug management mode.

Issue t applies to the cache invalidation instruction with the cache operating in writeback mode:

- t. The total clock count is the clock count shown plus the number of clocks required to write all "modified" cache lines to external memory.
- u. Non-standard processor core instructions. See Section 8.3.4 "Non-Standard Processor Core Instructions" on page 646 for details.

### 8.3.4 Non-Standard Processor Core Instructions

#### 8.3.4.1 DMINT - Enter Debug Management Mode

Opcode	Instruction	Clocks	Description
0F 39	DMINT	50-52	Enter DMM and call the DMI handler

#### Operation

IF (CPL<>0 OR (DMM\_INST\_EN=0 AND SMM=0 AND DMM=0))  
#UD;

ELSE

```

DMM_HEADER[AC_TEMP0] <= AC_TEMP0;
DMM_HEADER[TEMP6] <= TEMP6;
DMM_HEADER[DMM_FLAGS] <= DMM_FLAGS;
DMM_HEADER[EFLAGS] <= EFLAGS;
DMM_HEADER[CR0] <= CR0;
DMM_HEADER[NEXT_IP] <= IP OF INSTRUCTION AFTER DMINT;
DMM_HEADER[CURRENT_IP] <= IP OF DMINT instruction;
DMM_HEADER[CS_LIMIT] <= CS.LIMIT;
DMM_HEADER[CS_BASE] <= CS.BASE;
DMM_HEADER[CS_SELECTOR] <= CS.SELECTOR;
DMM_HEADER[CS_FLAGS] <= CS.FLAGS;
DMM_HEADER[SS_SELECTOR] <= SS.SELECTOR;
DMM_HEADER[SS_FLAGS] <= SS.FLAGS;
DMM_HEADER[XDR7] <= XDR7;
DMM_HEADER[XDR6] <= XDR6;
DMM_HEADER[DR7] <= DR7;
DMM_HEADER[DR6] <= DR6;
if (DMM_CACHE_DISABLE)
    CR0 <= 32'h00000010;
else
    CR0 <= {1'b0, CR0.CD, CR0.NW, 29'h010};
DR7 <= 32'h00000400;
XDR7 <= 32'h00000000;
SS.flags <= {SS.FLAGS[15:7], 2'b0, SS.FLAGS[4:0]};
CS.FLAGS <= 16'h009a;
CS.SELECTOR <= DMM_BASE >> 4;
CS.BASE <= DMM_BASE;
IF (DMM_LIMIT < 32'g100000)
    CS.LIMIT <= DMM_LIMIT;
    CS.G <= 1'b0;
else
    CS.LIMIT <= DMM_LIMIT | 32'hfff;
    CS.G <= 1'b1;
EFLAGS <= 32'h00000002;
DMM <= 1;
Jump to CS at offset of 0;

```

**Description**

The DMINT instruction saves portions of the processors state to the Debug Management Mode (DMM) header, alters the processors state for DMM, enters DMM, and then calls the DMM mode handler. Below is the format of the DMM header.

31	30	29	28	27	26	25	24	23	22	21	20	19	18	17	16	15	14	13	12	11	10	9	8	7	6	5	4	3	2	1	0							
DR6																-4																						
DR7																-8																						
XDR6																-C																						
XDR7																-10																						
SS FLAGS																SS SELECTOR											-14											
G	B	0	Av	0	1	DPL	1	0	E	W	A	INDEX											TI	RPL	-18													
CS FLAGS																CS SELECTOR											-18											
G	D	0	Av	0	1	DPL	1	1	C <sub>f</sub>	R	A	INDEX											TI	RPL	-18													
CS BASE																-1C																						
0								CS LIMIT																-20														
CURRENT_IP																																-24						
NEXT_IP																																-28						
CR0																																-2C						
EFLAGS																																-30						
0																c <sub>w</sub>	0	c <sub>r</sub>	0											V	X	0	H	S	0	0	0	-34
TEMP6																																-38						
AC TEMP0																																-3C						

**Flags Affected**

All EFlags are returned to their reset values.

**Exceptions**

#UD If current privilege level is not 0, or the DMM\_INST\_EN = 0 and if the processor is not in SMM and if the processor is not in DMM.

**Notes**

Data address breakpoints on DMM header addresses that occur when executing the DMINT instruction are ignored.

The DMINT instruction clears the V, X, and H bits of the DMM header. DMINT sets the S bit of the DMM header. The NEXT\_IP field of the DMM header will point to the instruction after the DMINT.

**8.3.4.2 ICEBP - Call Debug Exception Handler**

Opcode	Instruction	Clocks	Description
F1	ICEBP	29+	Call Debug Exception Handler

**Operation**

Same as an INT 1 instruction.

**Description**

The ICEBP instruction generates a call to the Debug exception handler. Its advantage over the INT 1 instruction is that it is a single byte opcode.

**Flags Affected**

The EFlags are pushed to the stack, and may then be modified before the debug exception handler is called. The EFlags may be restored by the debug exception handler's IRET.

**Notes**

Debuggers should not insert ICEBP instruction immediately after an instruction that alters the stack segment (MOV\_SS).

### 8.3.4.3 MOV - Move to/from Test Registers

Opcode	Instruction	Clocks	Description
0F 24 /r	MOV r32,tr	1	Move test register to general register
0F 26 /r	MOV tr, r32	2	Move general register to test register

#### Operation

```
IF (CPL <> 0) THEN
    #GP(0);
ELSE
    DEST <= SRC;
```

#### Description

The above forms of the MOV instruction store the contents of a test register (either TR0, TR1, TR2, TR3, TR4, TR5, TR6, or TR7) to a general purpose register (either EAX, ECX, EDX, EBX, ESP, EBP, ESI, or EDI), or load a test register from a general purpose register.

Thirty-two bit operands are always used with these instructions, regardless of the operand size attribute.

#### Flags Affected

None.

#### Exceptions

#GP(0) If the current privilege level is not 0.

#### Notes

These are not the Intel or AMD Geode LX processor test registers. Writing to a test register has no side effects. Reading from a test register has no side effects.

The **reg** field within the **ModR/M** byte specifies which of the test registers is involved. Reg values of 0, 1, 2, 3, 4, 5, 6, 7 specify TR0, TR1, TR2, TR3, TR4, TR5, TR6, and TR7 respectively. The two bits in the **mod** field are always 11. The **r/m** field specifies the general register involved.

Moving a value into a test register has no side effects.

Software other than DMI handlers should not use test registers, because DMI handlers might not preserve the contents of test registers. DMI handlers may use test registers as a place for saving and restoring general registers when the state of the stack is unknown.



**8.3.4.4 RDM - Leave Debug Management Mode**

Opcode	Instruction	Clocks	Description
0F 3A	RDM	36	Return from DMI

**Operation**

```

IF (CPL<>0 OR (DMM_INST_EN=0 AND SMM=0 AND DMM=0))
    #UD;
ELSE
    DR6 <= DMM_HEADER[DR6];
    DR7 <= DMM_HEADER[DR7];
    XDR6 <= DMM_HEADER[XDR6];
    XDR7 <= DMM_HEADER[XDR7];
    SS.FLAGS <= DMM_HEADER[SS.FLAGS];
    SS.SELECTOR <= DMM_HEADER[SS.SELECTOR];
    CPL <= DMM_HEADER[SS.DPL]
    CS.FLAGS <= DMM_HEADER[CS.FLAGS];
    CS.SELECTOR <= DMM_HEADER[CS.SELECTOR];
    CS.BASE <= DMM_HEADER[CS.BASE];
    CS.LIMIT <= DMM_HEADER[CS.LIMIT];
    CR0 <= DMM_HEADER[CR0];
    EFLAGS <= DMM_HEADER[EFLAGS];
    DMM <= 0;
    IF (DMM_HEADER[H])
        HALT PROCESSOR;
    ELSE
        JUMP to CS at OFFSET of DMM_HEADER[NEXT_IP];
    
```

**Description**

The RDM instruction restores the state of the processor from the DMM header, and then jumps to the address indicated in the NEXT\_IP field of the DMM header. Below is the format of the DMM header.

31	30	29	28	27	26	25	24	23	22	21	20	19	18	17	16	15	14	13	12	11	10	9	8	7	6	5	4	3	2	1	0		
DR6																												-4					
DR7																												-8					
XDR6																												-C					
XDR7																												-10					
SS FLAGS																SS SELECTOR												-14					
G	B	0	Av	0	1	DPL	1	0	E	W	A	INDEX						TI	RPL														
CS FLAGS																CS SELECTOR												-18					
G	D	0	Av	0	1	DPL	1	1	C <sub>f</sub>	R	A	INDEX						TI	RPL														
CS BASE																												-1C					
0																CS LIMIT												-20					
CURRENT_IP																																-24	
NEXT_IP																																-28	
CR0																																-2C	
EFLAGS																																-30	
0																c <sub>v</sub>	0	c <sub>r</sub>	0						V	X	0	H	S	0	0	0	-34
TEMP6																																-38	
AC TEMP0																																-3C	

**Flags Affected**

All bits of the EFlags register is restored from the DMM header.

**Exceptions**

#UD If current privilege level is not 0, or the DMM\_INST\_EN = 0 and if the processor is not in SMM and if the processor is not in DMM.

**Notes**

Data address breakpoints on DMM header addresses are ignored during the execution of the RSM instruction.

The RDM instruction does not check the values that it reads from the DMM header for validity.

The RDM instruction sets the current privilege level to the SS DPL value read from the DMM header.

If a RDM restores the processor to real mode, the VM bit of the EFlags register is cleared regardless of the state of the VM bit in the EFlags value of the DMM header.

If RDM restores the processor to a privilege level that is not 3, then the VM bit of the EFlags register is cleared, regardless of the contents of the VM bit in the EFlags value of the DMM header.

**8.3.4.5 RSDC - Restore Segment Register and Descriptor**

Opcode	Instruction	Clocks	Description
0F 79 /r	RSDC sr, m80	11	Restore descriptor from memory

**Operation**

IF (CPL<>0 OR (SMM\_INST\_EN=0 AND SMM=0 AND DMM=0))

#UD;

ELSE

SEG.DESCR <= MEM80;

**Description**

Restore the specified segment descriptor (either DS, ES, FS, GS, SS, or CS) from memory. Below is the format of the descriptor contents in memory.

31	30	29	28	27	26	25	24	23	22	21	20	19	18	17	16	15	14	13	12	11	10	9	8	7	6	5	4	3	2	1	0
																SELECTOR[15:3]										TI	RPL	+8			
BASE[31:24]								G	B	0	V	LIMIT[19:16]				1	DPL	1	X	E	W	A	BASE[23:16]							+4	
BASE[15:0]										LIMIT[15:0]																+0					

**Flags Affected**

None.

**Exceptions**

#UD If current privilege level is not 0, or the SMM\_INST\_EN = 0 and if the processor is not in SMM and if the processor is not in DMM.

**Notes**

The **reg** field within the **mod r/m** byte specifies which segment's register and descriptor should be restored. **Reg** fields of 0, 1, 2, 3, 4, and 5 specify the ES, CS, SS, DS, FS, and GS selectors respectively. The RSDC instruction is not recognized if the **reg** field is 6 or 7.

The RSDC instruction does not check its memory operand for validity. Care should be taken to always load valid data into segment registers.

A RSDC CS instruction's alteration of the CS base does not take affect until the execution of the next non-sequential instruction or pipeline flush. A pipeline flush could be caused by an external suspend, an external debug stall, or an SMC snoop hit. A RSDC CS instruction's alteration of the CS limit takes affect immediately.

A RSDC SS instruction alters the CPL to the DPL value. If the executable bit (X) is set, then the CS becomes unwritable.

External interrupts, single-step traps, and debug exceptions are not taken between a RSDC CS instruction and the RSLDT instruction (Section 8.3.4.6 on page 651).

**8.3.4.6 RSLDT - Restore Local Descriptor Table Register and Descriptor**

Opcode	Instruction	Clocks	Description
0F 7B	RSLDT m80	11	Restore LDTR from memory

**Operation**

```
IF (CPL<>0 OR (SMM_INST_EN=0 AND SMM=0 AND DMM=0))
    #UD;
ELSE
    LDT.DESCR <= MEM80;
```

**Description**

Restore the Local Descriptor Table register and descriptor from memory. Below is the format of the descriptor contents in memory.

31	30	29	28	27	26	25	24	23	22	21	20	19	18	17	16	15	14	13	12	11	10	9	8	7	6	5	4	3	2	1	0
																SELECTOR[15:3]											TI	RPL	+8		
BASE[31:24]								G	B	0	V	LIMIT[19:16]				1	DPL	1	0	E	W	A	BASE[23:16]							+4	
BASE[15:0]																LIMIT[15:0]													+0		

**Flags Affected**

None.

**Exceptions**

#UD If current privilege level is not 0, or the SMM\_INST\_EN = 0 and if the processor is not in SMM and if the processor is not in DMM.

**Notes**

The **reg** field within the **mod r/m** byte must be zero for the RSLDT instruction to be recognized.

The RSLDT instruction does not check its memory operand for validity. Care should be taken to always load valid data into the LDT.

8.3.4.7 RSM - Leave System Management Mode

Opcode	Instruction	Clocks	Description
0F AA	RSM	36	Return from SMI

Operation

```

IF (CPL<>0 OR (SMM_INST_EN=0 AND SMM=0 AND DMM=0))
    #UD;
ELSE
    SMM_CTL <= SMM_HEADER[SMM_CTL];
    SS.FLAGS <= SMM_HEADER[SS.FLAGS];
    CPL <= SMM_HEADER[SS.DPL];
    CS.LIMIT <= SMM_HEADER[CS.LIMIT];
    CS.BASE <= SMM_HEADER[CS.BASE];
    CS.SELECTOR <= SMM_HEADER[CS.SELECTOR];
    CS.FLAGS <= SMM_HEADER[CS.FLAGS];
    CR0 <= SMM_HEADER[CR0];
    EFLAGS <= SMM_HEADER[EFLAGS];
    IF (!DMM_CTL.DBG_AS_DMI)
        DR7 <= SMM_HEADER[DR7];
    IF (SMM_HEADER[N])
        SMM <= 1;
    else
        SMM <= 0;
    IF (SMM_HEADER[H])
        HALT PROCESSOR;
    ELSE
        JUMP to CS at OFFSET of SMM_HEADER[NEXT_IP];
    
```

Description

The RSM instruction restores the state of the processor from the System Management Mode (SMM) header, and then jumps to the address indicated by the NEXT\_IP field of the SMM header. Below is the format of the SMM header.

31	30	29	28	27	26	25	24	23	22	21	20	19	18	17	16	15	14	13	12	11	10	9	8	7	6	5	4	3	2	1	0			
DR7																												-4						
EFlags																												-8						
CR0																												-C						
CURRENT_IP																												-10						
NEXT_IP																												-14						
CS_FLAGS														Code Segment Selector																				
G	D	0	Av	0				1	DPL	1	1	Cf	R	A	INDEX										TI	RPL	-18							
CS_BASE																												-1C						
0														CS_LIMIT[19:0]																				
SS_FLAGS														SMM Flags																				
G	B	0	Av	0				1	DPL	1	0	E	W	A	C <sub>r</sub>	N										V	X	M	H	S	P	I	C <sub>w</sub>	-24
0														I/O SIZE							I/O ADDRESS[15:0]													
I/O_DATA																												-2C						
SMM_CTL																												-30						
0																												-34						

Flags Affected

All bits of the EFlags register is restored from the SMM header.

Exceptions

#UD If current privilege level is not 0, or the SMM\_INST\_EN = 0 and if the processor is not in SMM and if the processor is not in DMM.

**Notes**

The RSM instruction does not check the values that it reads from the SMM header for validity.

The RSM instruction set the current privilege level to the SS DPL value read from the SMM header.

If a RSM restores the processor to real mode, the VM bit of the EFlags register is cleared regardless of the state of the VM bit in the EFlags value of the SMM header.

If RSM restores the processor to a privilege level that is not 3, then the VM bit of the EFlags register is cleared, regardless of the contents of the VM bit in the EFlags value of the SMM header.

**8.3.4.8 RSTS - Restore Task Register and Descriptor**

Opcode	Instruction	Clocks	Description
0F 7D	RSTS m80	12	Restore TS from memory

**Operation**

IF (CPL<>0 OR (SMM\_INST\_EN=0 AND SMM=0 AND DMM=0))

#UD;

ELSE

TS.DESCR <= MEM80;

**Description**

Restore the Task register and descriptor from memory. Below is the format of the descriptor contents in memory.

31	30	29	28	27	26	25	24	23	22	21	20	19	18	17	16	15	14	13	12	11	10	9	8	7	6	5	4	3	2	1	0
																SELECTOR[15:3]											TI	RPL	+8		
BASE[31:24]								G	B	0	V	LIMIT[19:16]				1	DPL	1	0	E	W	A	BASE[23:16]								+4
BASE[15:0]																LIMIT[15:0]													+0		

**Flags Affected**

None.

**Exceptions**

#UD If current privilege level is not 0, or the SMM\_INST\_EN = 0 and if the processor is not in SMM and if the processor is not in DMM.

**Notes**

The **reg** field within the **mod r/m** byte must be zero for the RSTS instruction to be recognized.

The RSTS instruction does not check its memory operand for validity. Care should be taken to always load valid data into the TS.

**8.3.4.9 SETALC - Set AL to CF**

Opcode	Instruction	Clocks	Description
d6	SETALC	2	Set AL according to CF.

**Operation**

AL <= {8{CF}};

**Description**

IF the EFlags CF is set, then the SETALC instruction sets AL to FFh. Otherwise, SETALC sets AL to FFh.

**Flags Affected**

None.

**Exceptions**

None.

**Notes**

None.

**8.3.4.10 SMINT - Enter System Management Mode**

Opcode	Instruction	Clocks	Description
0F 38	SMINT	55	Enter SMM and call the SMI handler

**Operation**

IF (CPL<>0 OR (SMM\_INST\_EN=0 AND SMM=0 AND DMM=0))  
#UD;

ELSE

```

SMM_HEADER[SMM_CTL] <= SMM_CTL;
SMM_HEADER[I/O_DATA] <= 0;
SMM_HEADER[I/O_ADDRESS] <= 0;
SMM_HEADER[I/O_SIZE] <= 0;
SMM_HEADER[SMM_FLAGS] <= SMM_FLAGS;
SMM_HEADER[SS_FLAGS] <= SS.FLAGS;
SMM_HEADER[CS_LIMIT] <= CS.LIMIT;
SMM_HEADER[CS_BASE] <= CS.BASE;
SMM_HEADER[CS_SELECTOR] <= CS.SELECTOR;
SMM_HEADER[CS_FLAGS] <= CS.FLAGS;
SMM_HEADER[NEXT_IP] <= IP OF INSTRUCTION after SMINT;
SMM_HEADER[CURRENT_IP] <= IP of SMINT Instruction;
SMM_HEADER[CR0] <= CR0;
SMM_HEADER[EFLAGS] <= eflags;
SMM_HEADER[DR7] <= DR7;
CR0 <= {1'b0, CR0.CD, CR0.NW, 29'h010};
if (!DMM_CTL.DBG_AS_DMI)
    DR7 <= 32'h00000400;
SS.flags <= {SS.FLAGS[15:7], 2'b0, SS.FLAGS[4:0]};
CS.FLAGS <= 16'h009a;
CS.SELECTOR <= SMM_BASE >> 4;
CS.BASE <= SMM_BASE;
IF (SMM_LIMIT < 32'g100000)
    CS.LIMIT <= SMM_LIMIT;
    CS.G <= 1'b0;
else
    CS.LIMIT <= SMM_LIMIT | 32'hfff;
    CS.G <= 1'b1;
EFLAGS <= 32'h00000002;
SMM_CTL <= {SMM_CTL[31:3], 1'b0, SMM_CTL[1], 1'b0};
SMM <= 1;
Jump to CS at offset of 0;

```

**Description**

The SMINT instruction saves portions of the processors state to the System Management Mode (SMM) header, alters the processors state for SMM, enters SMM, and then calls the SMM handler. Below is the format of the SMM header.

31	30	29	28	27	26	25	24	23	22	21	20	19	18	17	16	15	14	13	12	11	10	9	8	7	6	5	4	3	2	1	0									
DR7																																-4								
EFlags																																-8								
CR0																																-C								
CURRENT_IP																																-10								
NEXT_IP																																-14								
CS_FLAGS																Code Segment Selector																-18								
G	D	0	Av	0				1	DPL	1	1	Cf	R	A	INDEX												TI	RPL												
CS_BASE																																-1C								
0																CS_LIMIT[19:0]																-20								
SS_FLAGS																SMM Flags																-24								
G	B	0	Av	0				1	DPL	1	0	E	W	A	c <sub>r</sub>	N												V	X	M	H	S	P	I	c <sub>w</sub>					
0																I/O SIZE								I/O ADDRESS[15:0]																-28
I/O_DATA																																-2C								
SMM_CTL																																-30								

**Flags Affected**

All EFlags are returned to their reset values.

**8.3.4.11 Exceptions**

#UD If current privilege level is not 0, or the SMM\_INST\_EN = 0 and if the processor is not in SMM and if the processor is not in DMM.

**Notes**

The SMINT instruction will clear the V, X, M, H, P, I, I/O ADDRESS, I/O SIZE, and I/O DATA fields of the SMM header. The CURRENT\_IP field of the SMM header will point to the SMINT instruction. The NEXT\_IP field of the SMM header will point to the instruction following the SMINT instruction. The S bit of the SMM header will be set.

### 8.3.4.12 SVDC - Save Segment Register and Descriptor

Opcode	Instruction	Clocks	Description
0F 78 /r	SVDC sr, m80	7	Restore descriptor from memory

#### Operation

IF (CPL<>0 OR (SMM\_INST\_EN=0 AND SMM=0 AND DMM=0))  
  #UD;  
ELSE  
  MEM80 <= SEG.DESCR;

#### Description

Write the specified segment descriptor (either DS, ES, FS, GS, SS, or CS) to memory. Below is the format of the descriptor contents in memory.

31	30	29	28	27	26	25	24	23	22	21	20	19	18	17	16	15	14	13	12	11	10	9	8	7	6	5	4	3	2	1	0
																SELECTOR[15:3]											TI	RPL	+8		
BASE[31:24]								G	B	0	V	LIMIT[19:16]				1	DPL	1	0	E	W	A	BASE[23:16]								+4
BASE[15:0]																LIMIT[15:0]													+0		

#### Flags Affected

None.

#### Exceptions

#UD If current privilege level is not 0, or the SMM\_INST\_EN = 0 and if the processor is not in SMM and if the processor is not in DMM.

#### Notes

The **reg** field within the **mod r/m** byte specifies which segment's register and descriptor should be written. **Reg** fields of 0, 1, 2, 3, 4, and 5 specify the ES, CS, SS, DS, FS, and GS selectors respectively. The RSDC instruction is not recognized if the **reg** field is 6 or 7.

### 8.3.4.13 SVLDT - Save Local Descriptor Table Register and Descriptor

Opcode	Instruction	Clocks	Description
0F 7A	SVLDT m80	7	Save LDT to memory

#### Operation

IF (CPL<>0 OR (SMM\_INST\_EN=0 AND SMM=0 AND DMM=0))  
  #UD;  
ELSE  
  MEM80 <= LDT.DESCR;

#### Description

Write the Local Descriptor Table register and descriptor to memory. Below is the format of the descriptor contents in memory.

31	30	29	28	27	26	25	24	23	22	21	20	19	18	17	16	15	14	13	12	11	10	9	8	7	6	5	4	3	2	1	0
																SELECTOR[15:3]											TI	RPL	+8		
BASE[31:24]								G	B	0	V	LIMIT[19:16]				1	DPL	1	0	E	W	A	BASE[23:16]								+4
BASE[15:0]																LIMIT[15:0]													+0		

#### Flags Affected

None.



**Exceptions**

#UD If current privilege level is not 0, or the SMM\_INST\_EN = 0 and if the processor is not in SMM and if the processor is not in DMM.

**Notes**

The *reg* field within the *mod r/m* byte must be zero for the SVLDT instruction to be recognized.

**8.3.4.14 SVTS - Save Task Register and Descriptor**

Opcode	Instruction	Clocks	Description
0F 7C	SVTS m80	8	Save TS to memory

**Operation**

```
IF (CPL<>0 OR (SMM_INST_EN=0 AND SMM=0 AND DMM=0))
    #UD;
ELSE
    MEM80 <= TS.DESCR;
```

**Description**

Write the Task register and descriptor to memory. Below is the format of the descriptor contents in memory..

31	30	29	28	27	26	25	24	23	22	21	20	19	18	17	16	15	14	13	12	11	10	9	8	7	6	5	4	3	2	1	0
																SELECTOR[15:3]											TI	RPL	+8		
BASE[31:24]								G	B	0	V	LIMIT[19:16]				1	DPL	1	0	E	W	A	BASE[23:16]							+4	
BASE[15:0]																LIMIT[15:0]													+0		

**Flags Affected**

None.

**Exceptions**

#UD If current privilege level is not 0, or the SMM\_INST\_EN = 0 and if the processor is not in SMM and if the processor is not in DMM.

**Notes**

The *reg* field within the *mod r/m* byte must be zero for the SVTS instruction to be recognized.

## 8.4 MMX™, FPU, and AMD 3DNow!™ Technology Instructions Sets

The CPU is functionally divided into the Floating Point Unit (FPU) unit and the Integer Unit. The FPU has been extended to process MMX, AMD 3DNow!, and floating point instructions in parallel with the Integer Unit.

When the Integer Unit detects an MMX instruction, the instruction is passed to the FPU for execution. The Integer Unit continues to execute instructions while the FPU executes the MMX instruction. If another MMX instruction is encountered, the second MMX instruction is placed in the MMX queue. Up to six MMX instructions can be queued.

When the Integer Unit detects a floating point instruction without memory operands, after two clock cycles the instruction passes to the FPU for execution. The Integer Unit continues to execute instructions while the FPU executes the floating point instruction. If another FPU instruction is encountered, the second FPU instruction is placed in the FPU queue. Up to four FPU instructions can be queued. In the event of an FPU exception, while other FPU instructions are queued, the state of the CPU is saved to ensure recovery.

The MMX instruction set (including extensions) is summarized in Table 8-28. The FPU instruction set is summarized in Table 8-29. The AMD 3DNow! instruction set (including extensions) is summarized in Table 8-30. The abbreviations used in the instruction sets are listed in Table 8-27.

**Note:** The following opcodes are reserved: D9D7, D9E2, D9E7, DDFC, DED8, DEDA, DEDC, DEDD, DEDE, and DFFC. If a reserved opcode is executed, unpredictable results may occur (exceptions are not generated).

**Table 8-27. MMX™, FPU, and AMD 3DNow!™ Instruction Set Table Legend**

Abbreviation	Description
<---	Result written.
[11 mm reg]	Binary or binary groups of digits.
mm	One of eight 64-bit MMX registers.
reg	A general purpose register.
<--- sat ---	If required, the resultant data is saturated to remain in the associated data range.
<--- move ---	Source data is moved to result location.
[byte]	Eight 8-bit BYTES are processed in parallel.
[word]	Four 16-bit WORDs are processed in parallel.
[dword]	Two 32-bit DWORDs are processed in parallel.
[qword]	One 64-bit QWORD is processed.
[sign xxx]	The BYTE, WORD, DWORD, or QWORD most significant bit is a sign bit.
mm1, mm2	MMX Register 1, MMX Register 2.
mod r/m	Mod and r/m byte encoding (Table 8-8 on page 622).
pack	Source data is truncated or saturated to next smaller data size, then concatenated.
packdw	Pack two DWORDs from source and two DWORDs from destination into four WORDs in the Destination register.
packwb	Pack four WORDs from source and four WORDs from destination into eight BYTES in the Destination register.
imm8	One-byte of immediate value.
memory64	64 bits in memory located in eight consecutive bytes.
memory32	32 bits in memory located in four consecutive bytes.
index 0 (imm8)	The value imm8 [1:0] *16.
index 1 (imm8)	The value imm8 [3:2] *16.
index 2 (imm8)	The value imm8 [5:4] *16.
index 3 (imm8)	The value imm8 [7:6] *16.
windex 0 (imm8)	The range given by [index0 (imm8) + 15: index0 (imm8)].

**Table 8-27. MMX™, FPU, and AMD 3DNow!™ Instruction Set Table Legend**

Abbreviation	Description
windex 1 (imm8)	The range given by [index1 (imm8) + 15: index1 (imm8)].
windex 2 (imm8)	The range given by [index2 (imm8) + 15: index2 (imm8)].
windex 3 (imm8)	The range given by [index3 (imm8) + 15: index3 (imm8)].
windexall (imm8)	The four different index # (imm8) ordered in the same way as word.
msb [bytes]	The most significant bits of the different eight bytes in QWORD, ordered from higher to lower bytes.
msb [words]	The most significant bits (sign bit) of the different four WORDs in a QWORD ordered from higher to lower.
trun	If required, the resultant data is truncated to remain within the associated range.
n	Stack register number.
TOS (Note 1)	Top of stack register pointed to by SSS in the status register.
ST(1) (Note 1)	FPU register next to TOS.
ST(n) (Note 1)	A specific FPU register, relative to TOS.
M.WI	16-bit integer operand from memory.
M.SI	32-bit integer operand from memory.
M.LI	64-bit integer operand from memory.
M.SR	32-bit real operand from memory.
M.DR	64-bit real operand from memory.
M.XR	80-bit real operand from memory.
M.BCD	18-digit BCD integer operand from memory.
CC	FPU condition code.
Env Regs	Status, Mode Control and Tag registers, Instruction Pointer and Operand Pointer.

Note 1. All references to TOS and ST(n) refer to stack layout prior to execution. Values popped off the stack are discarded. A POP from the stack increments the top of the stack pointer. A PUSH to the stack decrements the top of the stack pointer.

Table 8-28. MMX™ Instruction Set

MMX™ Instructions	Opcode	Operation	Clock Ct	Notes
<b>EMMS</b> <i>Empty MMX State</i>	0F77	Tag Word <--- FFFFh (empties the floating point tag word)	1	1
<b>MASKMOVQ</b> <i>Streaming (Cache Bypass) Store Using Byte Mask (Using EDI Register)</i>			2	
MMX Register1 with MMX Register2	0FF7 [11 mm1 mm2]	memory [edi] [byte] <--- MMX reg 2 [Sign byte] ? MMX reg 1 [byte] : memory [edi] [byte]		
<b>MOVD</b> <i>Move Doubleword</i>				
Register to MMX Register	0F6E [11 mm reg]	MMX reg [qword] <--- zero extend --- reg [dword]	1	
MMX Register to Register	0F7E [11 mm reg]	reg [qword] <--- MMX reg [low dword]	1	
Memory to MMX Register	0F6E [mod mm r/m]	MMX regr [qword] <--- zero extend --- memory [dword]	1	
MMX Register to Memory	0F7E [mod mm r/m]	Memory [dword] <--- MMX reg [low dword]	1	
<b>MOVNTQ</b> <i>Streaming (Cache Bypass) Store</i>			1	
MMX Register to Memory64	0FE7 [mod mm r/m]	Memory64 [qword] <--- MMX reg [qword]		
<b>MOVQ</b> <i>Move Quadword</i>				
MMX Register 2 to MMX Register 1	0F6F [11 mm1 mm2]	MMX reg 1 [qword] <--- MMX reg 2 [qword]	1	
MMX Register 1 to MMX Register 2	0F7F [11 mm1 mm2]	MMX reg 2 [qword] <--- MMX reg 1 [qword]	1	
Memory to MMX Register	0F6F [mod mm r/m]	MMX reg [qword] <--- memory[qword]	1	
MMX Register to Memory	0F7F [mod mm r/m]	Memory [qword] <--- MMX reg [qword]	1	
<b>PACKSSDW</b> <i>Pack Dword with Signed Saturation</i>				
MMX Register 2 to MMX Register 1	0F6B [11 mm1 mm2]	MMX reg 1 [qword] <--- packdw, signed sat --- MMX reg 2, MMX reg 1	2	
Memory to MMX Register	0F6B [mod mm r/m]	MMX reg [qword] <--- packdw, signed sat --- memory, MMX reg	2	
<b>PACKSSWB</b> <i>Pack Word with Signed Saturation</i>				
MMX Register 2 to MMX Register 1	0F63 [11 mm1 mm2]	MMX reg 1 [qword] <--- packwb, signed sat --- MMX reg 2, MMX reg 1	2	
Memory to MMX Register	0F63 [mod mm r/m]	MMX reg [qword] <--- packwb, signed sat --- memory, MMX reg	2	
<b>PACKUSWB</b> <i>Pack Word with Unsigned Saturation</i>				
MMX Register 2 to MMX Register 1	0F67 [11 mm1 mm2]	MMX reg 1 [qword] <--- packwb, unsigned sat --- MMX reg 2, MMX reg 1	2	
Memory to MMX Register	0F67 [mod mm r/m]	MMX reg [qword] <--- packwb, unsigned sat --- memory, MMX reg	2	
<b>PADDB</b> <i>Packed Add Byte with Wrap-Around</i>				
MMX Register 2 to MMX Register 1	0FFC [11 mm1 mm2]	MMX reg 1 [byte] <--- MMX reg 1 [byte] + MMX reg 2 [byte]	2	
Memory to MMX Register	0FFC [mod mm r/m]	MMX reg[byte] <--- memory [byte] + MMX reg [byte]	2	
<b>PADD</b> <i>Packed Add Dword with Wrap-Around</i>				
MMX Register 2 to MMX Register 1	0FFE [11 mm1 mm2]	MMX reg 1 [sign dword] <--- MMX reg 1 [sign dword] + MMX reg 2 [sign dword]	2	
Memory to MMX Register	0FFE [mod mm r/m]	MMX reg [sign dword] <--- memory [sign dword] + MMX reg [sign dword]	2	
<b>PADD SB</b> <i>Packed Add Signed Byte with Saturation</i>				
MMX Register 2 to MMX Register 1	0FEC [11 mm1 mm2]	MMX reg 1 [sign byte] <--- sat --- (MMX reg 1 [sign byte] + MMX reg 2 [sign byte])	2	
Memory to Register	0FEC [mod mm r/m]	MMX reg [sign byte] <--- sat --- (memory [sign byte] + MMX reg [sign byte])	2	
<b>PADD SW</b> <i>Packed Add Signed Word with Saturation</i>				
MMX Register 2 to MMX Register 1	0FED [11 mm1 mm2]	MMX reg 1 [sign word] <--- sat --- (MMX reg 1 [sign word] + MMX reg 2 [sign word])	2	
Memory to Register	0FED [mod mm r/m]	MMX reg [sign word] <--- sat --- (memory [sign word] + MMX reg [sign word])	2	
<b>PADDUSB</b> <i>Add Unsigned Byte with Saturation</i>				
MMX Register 2 to MMX Register 1	0FDC [11 mm1 mm2]	MMX reg 1 [byte] <--- sat --- (MMX reg 1 [byte] + MMX reg 2 [byte])	2	
Memory to Register	0FDC [mod mm r/m]	MMX reg [byte] <--- sat --- (memory [byte] + MMX reg [byte])	2	

**Table 8-28. MMX™ Instruction Set (Continued)**

MMX™ Instructions	Opcode	Operation	Clock Ct	Notes
<b>PADDUSW</b> <i>Add Unsigned Word with Saturation</i>				
MMX Register 2 to MMX Register 1	0FDD [11 mm1 mm2]	MMX reg 1 [word] <--- sat --- (MMX reg 1 [word] + MMX reg 2 [word])	2	
Memory to Register	0FDD [mod mm r/m]	MMX reg [word] <--- sat --- (memory [word] + MMX reg [word])	2	
<b>PADDW</b> <i>Packed Add Word with Wrap-Around</i>				
MMX Register 2 to MMX Register 1	0FFD [11 mm1 mm2]	MMX reg 1 [word] <--- MMX reg 1 [word] + MMX reg 2 [word]	2	
Memory to MMX Register	0FFD [mod mm r/m]	MMX reg [word] <--- memory [word] + MMX reg [word]	2	
<b>PAND</b> <i>Bitwise Logical AND</i>				
MMX Register 2 to MMX Register 1	0FDB [11 mm1 mm2]	MMX reg 1 [qword] --- MMX reg 1 [qword], <--- logic AND --- MMX reg 2 [qword]	2	
Memory to MMX Register	0FDB [mod mm r/m]	MMX reg [qword] memory [qword], <--- logic AND --- MMX reg [qword]	2	
<b>PANDN</b> <i>Bitwise Logical AND NOT</i>				
MMX Register 2 to MMX Register 1	0FDF [11 mm1 mm2]	MMX reg 1 [qword] NOT (MMX reg 1 [qword], <--- logic AND --- MMX reg 2 [qword])	2	
Memory to MMX Register	0FDF [mod mm r/m]	MMX reg [qword] --- NOT (MMX reg [qword], <--- logic AND --- Memory [qword])	2	
<b>PAVGB</b> <i>Packed Average of Unsigned Byte</i>				
MMX Register 1 with MMX Register 2	0FE0 [11 mm1 mm2]	MMX reg 1 [byte] <--- round up --- (MMX reg 1 [byte] + MMX reg 2 [byte] + 01h)/2	2	
MMX Register with Memory64	0FE0 [mod mm r/m]	MMX reg 1 [byte] <--- round up --- (MMX reg 1 [byte] + Memory64 [byte] + 01h)/2	2	
<b>PAVGW</b> <i>Packed Average of Unsigned Word</i>				
MMX Register 1 with MMX Register 2	0FE3 [11 mm1 mm2]	MMX reg 1 [word] <--- round up --- (MMX reg 1[word] + MMX reg 2 [word] + 01h)/2	2	
MMX Register with Memory	0FE3 [mod mm r/m]	MMX reg 1[word] <--- round up --- (MMX reg, [word] + Memory64 [word] + 01h)/2	2	
<b>PCMPEQB</b> <i>Packed Byte Compare for Equality</i>				
MMX Register 2 with MMX Register 1	0F74 [11 mm1 mm2]	MMX reg 1 [byte] <--- FFh --- if MMX reg 1 [byte] = MMX reg 2 [byte] MMX reg 1 [byte]<--- 00h --- if MMX reg 1 [byte] NOT = MMX reg 2 [byte]	2	
Memory with MMX Register	0F74 [mod mm r/m]	MMX reg [byte] <--- FFh --- if memory[byte] = MMX reg [byte] MMX reg [byte] <--- 00h --- if memory[byte] NOT = MMX reg [byte]	2	
<b>PCMPEQD</b> <i>Packed Dword Compare for Equality</i>				
MMX Register 2 with MMX Register 1	0F76 [11 mm1 mm2]	MMX reg 1 [dword] <--- FFFF FFFFh --- if MMX reg 1 [dword] = MMX reg 2 [dword] MMX reg 1 [dword]<--- 0000 0000h ---if MMX reg 1[dword] NOT = MMX reg 2 [dword]	2	
Memory with MMX Register	0F76 [mod mm r/m]	MMX reg [dword] <--- FFFF FFFFh --- if memory[dword] = MMX reg [dword] MMX reg [dword] <--- 0000 0000h --- if memory[dword] NOT = MMX reg [dword]	2	
<b>PCMPEQW</b> <i>Packed Word Compare for Equality</i>				
MMX Register 2 with MMX Register 1	0F75 [11 mm1 mm2]	MMX reg 1 [word] <--- FFFFh --- if MMX reg 1 [word] = MMX reg 2 [word] MMX reg 1 [word]<--- 0000h --- if MMX reg 1 [word] NOT = MMX reg 2 [word]	2	
Memory with MMX Register	0F75 [mod mm r/m]	MMX reg [word] <--- FFFFh --- if memory[word] = MMX reg [word] MMX reg [word] <--- 0000h --- if memory[word] NOT = MMX reg [word]	2	
<b>PCMPGTB</b> <i>Pack Compare Greater Than Byte</i>				
MMX Register 2 to MMX Register 1	0F64 [11 mm1 mm2]	MMX reg 1 [byte] <--- FFh --- if MMX reg 1 [byte] > MMX reg 2 [byte] MMX reg 1 [byte]<--- 00h --- if MMX reg 1 [byte] NOT > MMX reg 2 [byte]	2	
Memory with MMX Register	0F64 [mod mm r/m]	MMX reg [byte] <--- FFh --- if memory[byte] > MMX reg [byte] MMX reg [byte] <--- 00h --- if memory[byte] NOT > MMX reg [byte]	2	

Table 8-28. MMX™ Instruction Set (Continued)

MMX™ Instructions	Opcode	Operation	Clock Ct	Notes
<b>PCMPGTD Pack Compare Greater Than Dword</b>				
MMX Register 2 to MMX Register 1	0F66 [11 mm1 mm2]	MMX reg 1 [dword] <--- FFFF FFFFh --- if MMX reg 1 [dword] > MMX reg 2 [dword] MMX reg 1 [dword] <--- 0000 0000h --- if MMX reg 1 [dword] NOT > MMX reg 2 [dword]	2	
Memory with MMX Register	0F66 [mod mm r/m]	MMX reg [dword] <--- FFFF FFFFh --- if memory[dword] > MMX reg [dword] MMX reg [dword] <--- 0000 0000h --- if memory[dword] NOT > MMX reg [dword]	2	
<b>PCMPGTW Pack Compare Greater Than Word</b>				
MMX Register 2 to MMX Register 1	0F65 [11 mm1 mm2]	MMX reg 1 [word] <--- FFFFh --- if MMX reg 1 [word] > MMX reg 2 [word] MMX reg 1 [word] <--- 0000h --- if MMX reg 1 [word] NOT > MMX reg 2 [word]	2	
Memory with MMX Register	0F65 [mod mm r/m]	MMX reg [word] <--- FFFFh --- if memory[word] > MMX reg [word] MMX reg [word] <--- 0000h --- if memory[word] NOT > MMX reg [word]	2	
<b>PEXTRW Extract Word into Integer Register</b>				
Register 32, MMX Register 2 imm8	0FC5 [11 reg mm] #	Reg 32 [high word] <--- 0000 reg32 [low word] <--- MMX reg [windex0 (imm8)]	1	
<b>PINSRW Insert Word from Integer Register</b>				
MMX Register, Register 32 imm8	0FC4 [11 mm1 reg] #	tmp1 <--- 0 tmp1 [windex0 (imm8)] <--- reg 32 [low word] tmp2 <--- MMX reg tmp2 [windex0 (imm8)] <--- 0 MMX reg <--- tmp 1 Logic OR tmp2	2	
MMX Register, Memory 16, imm8	0FC4 [mod mm r/m] #	tmp1 <--- 0 tmp1 [windex0 (imm8)] <--- Memory 16 tmp2 <--- MMX reg tmp2 [windex0 (imm8)] <--- 0 MMX reg <--- tmp1 Logic OR tmp2 [windex 0 (imm8)]	2	
<b>PMADDWD Packed Multiply and Add</b>				
MMX Register 2 to MMX Register 1	0FF5 [11 mm1 mm2]	MMX reg 1 [low dword] <--- (MMX reg 1 [low dword] * MMX reg 2 [low sign word] + (MMX reg 1 [low dword] * MMX reg 2 [high sign word]) MMX reg 1 [high dword] <--- (MMX reg 1 [high dword] * MMX reg 2 [low sign word] + (MMX reg 1 [high dword] * MMX reg 2 [high sign word])	2	
Memory to MMX Register	0FF5 [mod mm r/m]	MMX reg 1 [low dword] <--- (memory [low dword] * MMX reg [low sign word] + (memory1 [low dword] * MMX reg [high sign word]) MMX reg 1 [high dword] <--- (memory [high dword] * MMX reg [low sign word] + (memory1 [high dword] * MMX reg [high sign word])	2	
<b>PMAXSW Packed Maximum Signed Word</b>				
MMX Register 1 with MMX Register 2	0FEE [11 mm1 mm2]	MMX reg 1 [word] <--- MMX reg 1 [word] --- if (MMX reg 1 [sign word] > MMX reg 2 [sign word]) MMX reg 1 [word] <--- MMX reg 2 [word] --- if (MMX reg 1 [sign word] NOT > MMX reg 2 [sign word])	2	
MMX Register with Memory64	0FEE [mod mm r/m]	MMX reg [word] <--- MMX reg [word] --- if (MMX reg [sign word] > Memory64 [word]) MMX reg [word] <--- Memory64 [word] --- if (MMX reg [sign word] NOT > Memory64 [sign word])	2	
<b>PMAXUB Packed Maximum Unsigned Byte</b>				
MMX Register 1 with MMX Register 2	0FDE [11 mm1 mm2]	MMX reg 1 [byte] <--- MMX reg 1 [byte] --- if (MMX reg 1 [byte] > MMX reg 2 [byte]) MMX reg 1 [byte] <--- MMX reg 2 [byte] --- if (MMX reg 1 [byte] NOT > MMX reg 2 [byte])	2	
MMX Register with Memory64	0FDE [mod mm r/m]	MMX reg [byte] <--- MMX reg [byte] --- if (MMX reg [byte] > Memory64 [byte]) MMX reg [byte] <--- Memory64 [byte] --- if (MMX reg [byte] NOT > Memory64 [byte])	2	

**Table 8-28. MMX™ Instruction Set (Continued)**

MMX™ Instructions	Opcode	Operation	Clock Ct	Notes
<b>PMINSW Packed Minimum Signed Word</b>				
MMX Register 1with MMX Register 2	0FEA [11 mm1 mm2]	MMX reg 1 [word] <--- MMX reg 1 [word] --- if (MMX reg 1 [sign word] ≤ MMX reg 2 [sign word]) MMX reg 1 [word] <--- MMX reg 2 [word] --- if (MMX reg 1 [sign word] NOT ≤ MMX reg 2 [sign word])	2	
MMX Register 1with Memory64	0FEA [mod mm r/m]	MMX reg [word] <--- MMX reg 1 [word] --- if (MMX reg [sign word] ≤ Memory64 [sign word]) MMX reg [word] <--- Memory64 [word] --- if (MMX reg [sign word] NOT ≤ Memory64 [sign word])	2	
<b>PMINUB Packed Minimum Unsigned Byte</b>				
MMX Register 1with MMX Register 2	0FDA [11 mm1 mm2]	MMX reg 1 [byte] <--- MMX reg 1 [byte] --- if (MMX reg 1 [byte] ≤ MMX reg 2 [byte])	2	
		MMX reg 1 [byte] <--- MMX reg 2 [byte] --- if (MMX reg 1 [byte] NOT ≤ MMX reg 2 [byte])	2	
MMX Register 1with Memory64	0FDA [mod mm r/m]	MMX reg [byte] <--- MMX reg [byte] --- if (MMX reg [byte] ≤ Memory64 [byte])	2	
		MMX reg [byte] <--- Memory64 [byte] --- if (MMX reg [byte] NOT ≤ Memory64 [byte])	2	
<b>PMOVMKB Move Byte Mask to Integer Register</b>			1	
Register 32 with MMX Register	0FD7 [11 reg mm]	reg32 <--- zero extend, MSB [bytes]		
<b>PMULHRW Packed Multiply High with Rounding</b>				
MMX Register 2 to MMX Register 1	0FB7 [11 mm1 mm2]	Multiply the signed packed word in the MMX register/memory with the signed packed word in the MMX register. Round with 1/2 bit 15, and store bits 30 - 15 of result in the MMX register.	2	
Memory to MMX Register	0FB7 [mod mm r/m]		2	
<b>PMULHUW Packed Multiply High Unsigned Word</b>				
MMX Register1 with MMX Register2	0FE4 [11 mm1 mm2]	MMX reg 1 [word] <--- high word --- (MMXreg 1[word] * MMX reg 2 [word])	2	
MMX Register with Memory64	0FE4 [mod mm r/m]	MMX reg [word] <--- high word --- (MMX reg [word] * Memory64 [word])	2	
<b>PMULHW Packed Multiply High</b>				
MMX Register 2 to MMX Register 1	0FE5 [11 mm1 mm2]	MMX reg 1 [word] <--- high word --- (MMX reg 1 [sign word] * MMX reg 2 [sign word])	2	
Memory to MMX Register	0FE5 [mod mm r/m]	MMX reg [word] <--- high word --- MMX reg [sign word] * Memory64 [sign word]	2	
<b>PMULLW Packed Multiply Low</b>				
MMX Register 2 to MMX Register 1	0FD5 [11 mm1 mm2]	MMX reg 1 [word] <--- low word --- (MMX reg 1 [sign word] * MMX reg 2 [sign word])	2	
Memory to MMX Register	0FD5 [mod mm r/m]	MMX reg 1 [word] <--- low word --- (MMX reg [sign word] * Memory64 [sign word])	2	
<b>POR Bitwise OR</b>				
MMX Register 2 to MMX Register 1	0FEB [11 mm1 mm2]	MMX reg 1 [qword] <--- MMX reg 1 [qword] logic OR MMX reg 2 [qword]	2	
Memory to MMX Register	0FEB [mod mm r/m]	MMX reg [qword] <--- MMX reg [qword] logic OR memory64 [qword]	2	
<b>PREFETCH NTA Move Data Closer to the Processor using the NTA Register</b>				
Memory8	0F18 [mod 000 r/m]			
<b>PREFETCH0 Move Data Closer to the Processor using the T0 Register</b>				
Memory8	0F18 [mod 001 r/m]			
<b>PREFETCH1 Move Data Closer to the Processor using the T1 Register</b>				
Memory8	0F18 [mod 010 r/m]			
<b>PREFETCH2 Move Data Closer to the Processor using the T2 Register</b>				
Memory8	0F18 [mod 011 r/m]			
<b>PSADBW Packed Sum of Absolute Byte Differences</b>				
MMX Register1 with MMX Register2	0FF6 [11 mm1 mm2]	MMX reg 1 [low word] <--- Sum --- (abs --- (MMXreg 1[byte] - MMX reg 2 [byte])) MMX reg 1 [upper three words] <--- 0	3	
MMX Register with Memory64	0FF6 [mod mm r/m]	MMX reg [low word] <--- Sum --- (abs --- (MMX reg [byte] - Memory64 [byte])) MMX reg [up three word] <--- 0	3	

Table 8-28. MMX™ Instruction Set (Continued)

MMX™ Instructions	Opcode	Operation	Clock Ct	Notes
<b>PSHUFW Packed Shuffle Word</b>				
MMX Register1, MMX Register2, imm8	0F70 [11 mm1 mm2] #	MMX reg 1 [word] <--- MMX reg 2 [windexall (imm8)]	2	
MMX Register, Memory64, imm8	0F70 [mod mm r/m] #	MMX reg [word] <--- Memory64 [windexall (imm8)]	2	
<b>PSLLD Packed Shift Left Logical Dword</b>				
MMX Register 1 by MMX Register 2	0FF2 [11 mm1 mm2]	MMX reg 1 [dword] <--- MMX reg 1 [dword] shift left by MMX reg 2 [dword], shifting in zeroes	2	
MMX Register by Memory	0FF2 [mod mm r/m]	MMX reg [dword] <--- MMX reg [dword] shift left by memory [dword], shifting in zeroes	2	
MMX Register by immediate	0F72 [11 110 mm] #	MMX reg [dword] <--- MMX reg [dword] shift left by [im byte], shifting in zeroes	2	
<b>PSLLQ Packed Shift Left Logical Qword</b>				
MMX Register 1 by MMX Register 2	0FF3 [11 mm1 mm2]	MMX reg 1 [qword] <--- MMX reg 1 [qword] shift left by MMX reg 2 [qword], shifting in zeroes	2	
MMX Register by Memory	0FF3 [mod mm r/m]	MMX reg [qword] <--- MMX reg [qword] shift left by memory [qword], shifting in zeroes	2	
MMX Register by immediate	0F73 [11 110 mm] #	MMX reg [qword] <--- MMX reg [qword] shift left by [im byte], shifting in zeroes	2	
<b>PSLLW Packed Shift Left Logical Word</b>				
MMX Register 1 by MMX Register 2	0FF1 [11 mm1 mm2]	MMX reg 1 [word] <--- MMX reg 1 [word] shift left by MMX reg 2 [word], shifting in zeroes	2	
MMX Register by Memory	0FF1 [mod mm r/m]	MMX reg [word] <--- MMX reg [word] shift left by memory [word], shifting in zeroes	2	
MMX Register by immediate	0F71 [11 110mm] #	MMX reg [word] <--- MMX reg [word] shift left by [im byte], shifting in zeroes	2	
<b>PSRAD Packed Shift Right Arithmetic Dword</b>				
MMX Register 1 by MMX Register 2	0FE2 [11 mm1 mm2]	MMX reg 1 [dword] <--- MMX reg 1 [dword] shift right by MMX reg 2 [dword], shifting in sign bits	2	
MMX Register by Memory	0FE2 [mod mm r/m]	MMX reg [dword] <--- MMX reg [dword] shift right by memory [dword], shifting in sign bits	2	
MMX Register by immediate	0F72 [11 100 mm] #	MMX reg [dword] <--- MMX reg [dword] shift right by [im byte], shifting in sign bits	2	
<b>PSRAW Packed Shift Right Arithmetic Word</b>				
MMX Register 1 by MMX Register 2	0FE1 [11 mm1 mm2]	MMX reg 1 [word] <--- MMX reg 1 [word] shift right by MMX reg 2 [word], shifting in sign bits	2	
MMX Register by Memory	0FE1 [mod mm r/m]	MMX reg [word] <--- MMX reg [word] shift right by memory [word], shifting in sign bits	2	
MMX Register by immediate	0F71 [11 100 mm] #	MMX reg [word] <--- MMX reg [word] shift right by [im byte], shifting in sign bits	2	
<b>PSRLD Packed Shift Right Logical Dword</b>				
MMX Register 1 by MMX Register 2	0FD2 [11 mm1 mm2]	MMX reg 1 [dword] <--- MMX reg 1 [dword] shift right by MMX reg 2 [dword], shifting in zeroes	2	
MMX Register by Memory	0FD2 [mod mm r/m]	MMX reg [dword] <--- MMX reg [dword] shift right by memory [dword], shifting in zeroes	2	
MMX Register by immediate	0F72 [11 010 mm] #	MMX reg [dword] <--- MMX reg [dword] shift right by [im byte], shifting in zeroes	2	
<b>PSRLQ Packed Shift Right Logical Qword</b>				
MMX Register 1 by MMX Register 2	0FD3 [11 mm1 mm2]	MMX reg 1 [qword] <--- MMX reg 1 [qword] shift right by MMX reg 2 [qword], shifting in zeroes	3	
MMX Register by Memory	0FD3 [mod mm r/m]	MMX reg [qword] <--- MMX reg [qword] shift right by memory [qword], shifting in zeroes	3	
MMX Register by immediate	0F73 [11 010 mm] #	MMX reg [qword] <--- MMX reg [qword] shift right by [im byte], shifting in zeroes	3	
<b>PSRLW Packed Shift Right Logical Word</b>				
MMX Register 1 by MMX Register 2	0FD1 [11 mm1 mm2]	MMX reg 1 [word] <--- MMX reg 1 [word] shift right by MMX reg 2 [word], shifting in zeroes	2	
MMX Register by Memory	0FD1 [mod mm r/m]	MMX reg [word] <--- MMX reg [word] shift right by memory [word], shifting in zeroes	2	
MMX Register by immediate	0F71 [11 010 mm] #	MMX reg [word] <--- MMX reg [word] shift right by imm [word], shifting in zeroes	2	



Table 8-28. MMX™ Instruction Set (Continued)

MMX™ Instructions	Opcode	Operation	Clock Ct	Notes
<b>PSUBB Subtract Byte With Wrap-Around</b>				
MMX Register 2 to MMX Register 1	0FF8 [11 mm1 mm2]	MMX reg 1 [byte] <--- MMX reg 1 [byte] - MMX reg 2 [byte]	2	
Memory to MMX Register	0FF8 [mod mm r/m]	MMX reg [byte] <--- MMX reg [byte] - memory [byte]	2	
<b>PSUBD Subtract Dword With Wrap-Around</b>				
MMX Register 2 to MMX Register 1	0FFA [11 mm1 mm2]	MMX reg 1 [dword] <--- MMX reg 1 [dword] - MMX reg 2 [dword]	2	
Memory to MMX Register	0FFA [mod mm r/m]	MMX reg [dword] <--- MMX reg [dword] - memory64 [dword]	2	
<b>PSUBSB Subtract Byte Signed With Saturation</b>				
MMX Register 2 to MMX Register 1	0FE8 [11 mm1 mm2]	MMX reg 1 [sign byte] <--- sat -- (MMX reg 1 [sign byte] subtract MMX reg 2 [sign byte])	2	
Memory to MMX Register	0FE8 [mod mm r/m]	MMX reg [sign byte] <--- sat --- (MMX reg [sign byte] subtract memory64 [sign byte])	2	
<b>PSUBSW Subtract Word Signed With Saturation</b>				
MMX Register 2 to MMX Register 1	0FE9 [11 mm1 mm2]	MMX reg 1 [sign word] <--- sat --- (MMX reg 1 [sign word] - MMX reg 2 [sign word])	2	
Memory to MMX Register	0FE9 [mod mm r/m]	MMX reg [sign word] <--- sat --- (MMX reg [sign word] - memory64 [sign word])	2	
<b>PSUBUSB Subtract Byte Unsigned With Saturation</b>				
MMX Register 2 to MMX Register 1	0FD8 [11 mm1 mm2]	MMX reg 1 [byte] <--- sat --- (MMX reg 1 [byte] - MMX reg 2 [byte])	2	
Memory to MMX Register	0FD8 [11 mm reg]	MMX reg [byte] <--- sat --- (MMX reg [byte] - memory64 [byte])	2	
<b>PSUBUSW Subtract Word Unsigned With Saturation</b>				
MMX Register 2 to MMX Register 1	0FD9 [11 mm1 mm2]	MMX reg 1 [word] <--- sat --- (MMX reg 1 [word] - MMX reg 2 [word])	2	
Memory to MMX Register	0FD9 [11 mm reg]	MMX reg [word] <--- sat --- (MMX reg [word] - memory64 [word])	2	
<b>PSUBW Subtract Word With Wrap-Around</b>				
MMX Register 2 to MMX Register 1	0FF9 [11 mm1 mm2]	MMX reg 1 [word] <--- (MMX reg 1 [word] - MMX reg 2 [word])	2	
Memory to MMX Register	0FF9 [mod mm r/m]	MMX reg [word] <--- (MMX reg [word] - memory64 [word])	2	
<b>PUNPCKHBW Unpack High Packed Byte, Data to Packed Words</b>				
MMX Register 2 to MMX Register 1	0F68 [11 mm1 mm2]	MMX reg 1 [word] <--- {MMX reg 1 [high byte], MMX reg 2 [high byte]}	2	
Memory to MMX Register	0F68 [11 mm reg]	MMX reg [word] <--- {memory64 [high byte], MMX reg [high byte]}	2	
<b>PUNPCKHDQ Unpack High Packed Dword, Data to Qword</b>				
MMX Register 2 to MMX Register 1	0F6A [11 mm1 mm2]	MMX reg 1 <--- MMX reg 1 [high dword], MMX reg 2 [high dword]	2	
Memory to MMX Register	0F6A [11 mm reg]	MMX reg <--- {memory64 [high dword], MMX reg [high dword]}	2	
<b>PUNPCKHWD Unpack High Packed Word, Data to Packed Dwords</b>				
MMX Register 2 to MMX Register 1	0F69 [11 mm1 mm2]	MMX reg 1 [dword] <--- MMX reg 1 [high word], MMX reg 2 [high word]	2	
Memory to MMX Register	0F69 [11 mm reg]	MMX reg [dword] <--- memory64 [high word], MMX reg [high word]	2	
<b>PUNPCKLBW Unpack Low Packed Byte, Data to Packed Words</b>				
MMX Register 2 to MMX Register 1	0F60 [11 mm1 mm2]	MMX reg 1 [word] <--- MMX reg 1 [low byte], MMX reg 2 [low byte]	2	
Memory to MMX Register	0F60 [11 mm reg]	MMX reg [word] <--- memory64 [low byte], MMX reg [low byte]	2	
<b>PUNPCKLDQ Unpack Low Packed Dword, Data to Qword</b>				
MMX Register 2 to MMX Register 1	0F62 [11 mm1 mm2]	MMX reg 1 <--- MMX reg 1 [low dword], MMX reg 2 [low dword]	2	
Memory to MMX Register	0F62 [11 mm reg]	MMX reg <--- memory64 [low dword], MMX reg [low dword]	2	
<b>PUNPCKLWD Unpack Low Packed Word, Data to Packed Dwords</b>				
MMX Register 2 to MMX Register 1	0F61 [11 mm1 mm2]	MMX reg 1 [dword] <--- MMX reg 1 [low word], MMX reg 2 [low word]	2	
Memory to MMX Register	0F61 [11 mm reg]	MMX reg [dword] <--- memory64 [low word], MMX reg [low word]	2	

**Table 8-28. MMX™ Instruction Set (Continued)**

MMX™ Instructions	Opcode	Operation	Clock Ct	Notes
<b>PXOR</b> <i>Bitwise XOR</i>				
MMX Register 2 to MMX Register 1	0FEF [11 mm1 mm2]	MMX reg 1 [qword] --- MMX reg 1 [qword], <--- logic exclusive OR MMX reg 2 [qword]	2	
Memory to MMX Register	0FEF [11 mm reg]	MMX reg [qword] --- memory64 [qword], <--- logic exclusive OR MMX reg [qword]	2	
<b>SFENCE</b> <i>Store Fence</i>				
	0FAE [mod 111 r/m]			

- 1) This instruction must wait for the FPU pipeline to flush. Cycle count depends on what instructions are in the pipeline.

**Table 8-29. FPU Instruction Set**

FPU Instruction	Opcode	Operation	Clock Ct Single/Dbf (or extended)	Notes
<b>F2XM1</b> <i>Function Evaluation 2x-1</i>	D9 F0	TOS <--- 2 <sup>TOS</sup> -1	145 - 166	2
<b>FABS</b> <i>Floating Absolute Value</i>	D9 E1	TOS <---   TOS	1	3
<b>FADD</b> <i>Floating Point Add</i>				
Top of Stack	DC [1100 0 n]	ST(n) <--- ST(n) + TOS	1/6	
80-bit Register	D8 [1100 0 n]	TOS <--- TOS + ST(n)	1/6	
64-bit Real	DC [mod 000 r/m]	TOS <--- TOS + M.DR	1/6	
32-bit Real	D8 [mod 000 r/m]	TOS <--- TOS + M.SR	1/6	
<b>FADDP</b> <i>Floating Point Add, Pop</i>	DE [1100 0 n]	ST(n) <--- ST(n) + TOS; then pop TOS	1/6	
<b>FIADD</b> <i>Floating Point Integer Add</i>				
32-bit integer	DA [mod 000 r/m]	TOS <--- TOS + M.SI	2/7	
16-bit integer	DE [mod 000 r/m]	TOS <--- TOS + M.WI	2/7	
<b>FCHS</b> <i>Floating Change Sign</i>	D9 E0	TOS <--- - TOS	1	
<b>FCLEX</b> <i>Clear Exceptions</i>	(9B) DB E2	Wait then Clear Exceptions	1+	2
<b>FNCLEX</b> <i>Clear Exceptions</i>	DB E2	Clear Exceptions	1+	2
<b>FCMOVB</b> <i>Floating Point Conditional Move if Below</i>	DA [1100 0 n]	If (CF=1) ST(0) <--- ST(n)	1	3
<b>FCMOVE</b> <i>Floating Point Conditional Move if Equal</i>	DA [1100 1 n]	If (ZF=1) ST(0) <--- ST(n)	1	3
<b>FCMOVBE</b> <i>Floating Point Conditional Move if Below or Equal</i>	DA [1101 0 n]	If (CF=1 or ZF=1) ST(0) <--- ST(n)	1	3
<b>FCMOVU</b> <i>Floating Point Conditional Move if Unordered</i>	DA [1101 1 n]	If (PF=1) ST(0) <--- ST(n)	1	3
<b>FCMOVNB</b> <i>Floating Point Conditional Move if Not Below</i>	DB [1100 0 n]	If (CF=0) ST(0) <--- ST(n)	1	3
<b>FCMOVNE</b> <i>Floating Point Conditional Move if Not Equal</i>	DB [1100 1 n]	If (ZF=0) ST(0) <--- ST(n)	1	3
<b>FCMOVNBE</b> <i>Floating Point Conditional Move if Not Below or Equal</i>	DB [1101 0 n]	If (CF=0 and ZF=0) ST(0) <--- ST(n)	1	3
<b>FCMOVNU</b> <i>Floating Point Conditional Move if Not Unordered</i>	DB [1101 1 n]	If (PF=0) ST(0) <--- ST(n)	1	3
<b>FCOM</b> <i>Floating Point Compare</i>				
80-bit Register	D8 [1101 0 n]	CC set by TOS - ST(n)	1/6	
64-bit Real	DC [mod 010 r/m]	CC set by TOS - M.DR	1/6	
32-bit Real	D8 [mod 010 r/m]	CC set by TOS - M.SR	1/6	
<b>FCOMP</b> <i>Floating Point Compare, Pop</i>				
80-bit Register	D8 [1101 1 n]	CC set by TOS - ST(n); then pop TOS	1/6	
64-bit Real	DC [mod 011 r/m]	CC set by TOS - M.DR; then pop TOS	1/6	
32-bit Real	D8 [mod 011 r/m]	CC set by TOS - M.SR; then pop TOS	1/6	
<b>FCOMPP</b> <i>Floating Point Compare, Pop Two Stack Elements</i>	DE D9	CC set by TOS - ST(1); then pop TOS and ST(1)	1/6	
<b>FCOMI</b> <i>Floating Point Compare Real and Set EFLAGS</i>				
80-bit Register	DB [1111 0 n]	EFLAG set by TOS - ST(n)	1/6	
<b>FCOMIP</b> <i>Floating Point Compare Real and Set EFLAGS, Pop</i>				
80-bit Register	DF [1111 0 n]	EFLAG set by TOS - ST(n); then pop TOS	1/6	
<b>FUCOMI</b> <i>Floating Point Unordered Compare Real and Set EFLAGS</i>				
80-bit Integer	DB [1110 1 n]	EFLAG set by TOS - ST(n)	1/6	
<b>FUCOMIP</b> <i>Floating Point Unordered Compare Real and Set EFLAGS, Pop</i>				
80-bit Integer	DF [1110 1 n]	EFLAG set by TOS - ST(n); then pop TOS	1/6	
<b>FICOM</b> <i>Floating Point Integer Compare</i>				
32-bit integer	DA [mod 010 r/m]	CC set by TOS - M.WI	2/7	
16-bit integer	DE [mod 010 r/m]	CC set by TOS - M.SI	2/7	
<b>FICOMP</b> <i>Floating Point Integer Compare, Pop</i>				
32-bit integer	DA [mod 011 r/m]	CC set by TOS - M.WI; then pop TOS	2/7	
16-bit integer	DE [mod 011 r/m]	CC set by TOS - M.SI; then pop TOS	2/7	
<b>FCOS</b> <i>Function Evaluation: Cos(x)</i>	D9 FF	TOS <--- COS(TOS)	146 - 215	1

Table 8-29. FPU Instruction Set (Continued)

FPU Instruction	Opcode	Operation	Clock Ct Single/DbI (or extended)	Notes
<b>FDECSTP</b> <i>Decrement Stack pointer</i>	D9 F6	Decrement top of stack pointer	1	3
<b>FDIV</b> <i>Floating Point Divide</i>				
Top of Stack	DC [1111 1 n]	ST(n) <--- ST(n) / TOS	12/47	
80-bit Register	D8 [1111 0 n]	TOS <--- TOS / ST(n)	12/47	
64-bit Real	DC [mod 110 r/m]	TOS <--- TOS / M.DR	12/47	
32-bit Real	D8 [mod 110 r/m]	TOS <--- TOS / M.SR	12/47	
<b>FDIVP</b> <i>Floating Point Divide, Pop</i>	DE [1111 1 n]	ST(n) <--- ST(n) / TOS; then pop TOS	12/47	
<b>FDIVR</b> <i>Floating Point Divide Reversed</i>				
Top of Stack	DC [1111 0 n]	TOS <--- ST(n) / TOS	12/47	
80-bit Register	D8 [1111 1 n]	ST(n) <--- TOS / ST(n)	12/47	
64-bit Real	DC [mod 111 r/m]	TOS <--- M.DR / TOS	12/47	
32-bit Real	D8 [mod 111 r/m]	TOS <--- M.SR / TOS	12/47	
<b>FDIVRP</b> <i>Floating Point Divide Reversed, Pop</i>	DE [1111 0 n]	ST(n) <--- TOS / ST(n); then pop TOS	12/47	
<b>FIDIV</b> <i>Floating Point Integer Divide</i>				
32-bit Integer	DA [mod 110 r/m]	TOS <--- TOS / M.SI	13/48	
16-bit Integer	DE [mod 110 r/m]	TOS <--- TOS / M.WI	13/48	
<b>FIDIVR</b> <i>Floating Point Integer Divide Reversed</i>				
32-bit Integer	DA [mod 111 r/m]	TOS <--- M.SI / TOS	13/48	
16-bit Integer	DE [mod 111 r/m]	TOS <--- M.WI / TOS	13/48	
<b>FFREE</b> <i>Free Floating Point Register</i>	DD [1100 0 n]	TAG(n) <--- Empty	1	3
<b>FINCSTP</b> <i>Increment Stack Pointer</i>	D9 F7	Increment top-of-stack pointer	1	3
<b>FINIT</b> <i>Initialize FPU</i>	(9B)DB E3	Wait, then initialize	1	2
<b>FNINIT</b> <i>Initialize FPU</i>	DB E3	Initialize	1	2
<b>FLD</b> <i>Load Data to FPU Register</i>				
Top of Stack	D9 [1100 0 n]	Push ST(n) onto stack	1	3
80-bit Real	DB [mod 101 r/m]	Push M.XR onto stack	1	3
64-bit Real	DD [mod 000 r/m]	Push M.DR onto stack	1	3
32-bit Real	D9 [mod 000 r/m]	Push M.SR onto stack	1	3
<b>FBLD</b> <i>Load Packed BCD Data to FPU Register</i>	DF [mod 100 r/m]	Push M.BCD onto stack	28	
<b>FILD</b> <i>Load Integer Data to FPU Register</i>				
64-bit Integer	DF [mod 101 r/m]	Push M.LI onto stack	4	
32-bit Integer	DB [mod 000 r/m]	Push M.SI onto stack	1	
16-bit Integer	DF [mod 000 r/m]	Push M.WI onto stack	1	
<b>FLD1</b> <i>Load Floating Const.= 1.0</i>	D9 E8	Push 1.0 onto stack	1	3
<b>FLDCW</b> <i>Load FPU Mode Control Register</i>	D9 [mod 101 r/m]	Ctl Word <--- Memory	1	3
<b>FLDENV</b> <i>Load FPU Environment</i>	D9 [mod 100 r/m]	Env Regs <--- Memory	1	3
<b>FLDL2E</b> <i>Load Floating Const.= Log<sub>2</sub>(e)</i>	D9 EA	Push Log <sub>2</sub> (e) onto stack	1	3
<b>FLDL2T</b> <i>Load Floating Const.= Log<sub>2</sub>(10)</i>	D9 E9	Push Log <sub>2</sub> (10) onto stack	1	3
<b>FLDLG2</b> <i>Load Floating Const.= Log<sub>10</sub>(2)</i>	D9 EC	Push Log <sub>10</sub> (2) onto stack	1	3
<b>FLDLN2</b> <i>Load Floating Const.= Ln(2)</i>	D9 ED	Push Log <sub>e</sub> (2) onto stack	1	3
<b>FLDPI</b> <i>Load Floating Const.= π</i>	D9 EB	Push π onto stack	1	3
<b>FLDZ</b> <i>Load Floating Const.= 0.0</i>	D9 EE	Push 0.0 onto stack	1	3
<b>FMUL</b> <i>Floating Point Multiply</i>				
Top of Stack	DC [1100 1 n]	ST(n) <--- ST(n) × TOS	1/10	
80-bit Register	D8 [1100 1 n]	TOS <--- TOS × ST(n)	1/10	
64-bit Real	DC [mod 001 r/m]	TOS <--- TOS × M.DR	1/10	
32-bit Real	D8 [mod 001 r/m]	TOS <--- TOS × M.SR	1/10	
<b>FMULP</b> <i>Floating Point Multiply &amp; Pop</i>	DE [1100 1 n]	ST(n) <--- ST(n) × TOS; then pop TOS	1/10	
<b>FIMUL</b> <i>Floating Point Integer Multiply</i>				
32-bit Integer	DA [mod 001 r/m]	TOS <--- TOS × M.SI	2/11	
16-bit Integer	DE [mod 001 r/m]	TOS <--- TOS × M.WI	2/11	
<b>FNOP</b> <i>No Operation</i>	D9 D0	No Operation	1	3

**Table 8-29. FPU Instruction Set (Continued)**

FPU Instruction	Opcode	Operation	Clock Ct Single/DbI (or extended)	Notes
<b>FPATAN</b> <i>Function Eval: Tan-1(y/x)</i>	D9 F3	ST(1) <--- ATAN[ST(1) / TOS]; then pop TOS	269 - 354	3
<b>FPREM</b> <i>Floating Point Remainder</i>	D9 F8	TOS <--- Rem[TOS / ST(1)]	53 - 208	
<b>FPREM1</b> <i>Floating Point Remainder IEEE</i>	D9 F5	TOS <--- Rem[TOS / ST(1)]	53 - 208	
<b>FPTAN</b> <i>Function Eval: Tan(x)</i>	D9 F2	TOS <--- TAN(TOS); then push 1.0 onto stack	217 - 232	1, 2
<b>FRNDINT</b> <i>Round to Integer</i>	D9 FC	TOS <--- Round(TOS)	12	
<b>FRSTOR</b> <i>Load FPU Environment and Register</i>	DD [mod 100 r/m]	Restore state	19	2
<b>FSAVE</b> <i>Save FPU Environment and Register</i>	(9B)DD [mod 110 r/m]	Wait, then save state	19	2
<b>FNSAVE</b> <i>Save FPU Environment and Register</i>	DD [mod 110 r/m]	Save state	19	2
<b>FSCALE</b> <i>Floating Multiply by 2n</i>	D9 FD	TOS <--- TOS × 2 <sup>(ST(1))</sup>	3	
<b>FSIN</b> <i>Function Evaluation: Sin(x)</i>	D9 FE	TOS <--- SIN(TOS)	130 - 215	1
<b>FSINCOS</b> <i>Function Eval.: Sin(x)&amp; Cos(x)</i>	D9 FB	temp <--- TOS; TOS <--- SIN(temp); then push COS(temp) onto stack	345 - 374	1, 2
<b>FSQRT</b> <i>Floating Point Square Root</i>	D9 FA	TOS <--- Square Root of TOS	13/54	
<b>FST</b> <i>Store FPU Register</i>				
FPU Stack	DD [1101 0 n]	ST(n) <--- TOS	1	3
64-bit Real	DD [mod 010 r/m]	M.DR <--- TOS	6	
32-bit Real	D9 [mod 010 r/m]	M.SR <--- TOS	1/4	
<b>FSTP</b> <i>Store FPU Register, Pop</i>				
FPU Stack	DB [1101 1 n]	ST(n) <--- TOS; then pop TOS	1	3
80-bit Real	DB [mod 111 r/m]	M.XR <--- TOS; then pop TOS	1	3
64-bit Real	DD [mod 011 r/m]	M.DR <--- TOS; then pop TOS	6	
32-bit Real	D9 [mod 011 r/m]	M.SR <--- TOS; then pop TOS	1/4	
<b>FBSTP</b> <i>Store BCD Data, Pop</i>				
	DF [mod 110 r/m]	M.BCD <--- TOS; then pop TOS	82	
<b>FIST</b> <i>Store Integer FPU Register</i>				
32-bit Integer	DB [mod 010 r/m]	M.SI <--- TOS	4	
16-bit Integer	DF [mod 010 r/m]	M.WI <--- TOS	3	
<b>FISTP</b> <i>Store Integer FPU Register, Pop</i>				
64-bit Integer	DF [mod 111 r/m]	M.LI <--- TOS; then pop TOS	6	
32-bit Integer	DB [mod 011 r/m]	M.SI <--- TOS; then pop TOS	4	
16-bit Integer	DF [mod 011 r/m]	M.WI <--- TOS; then pop TOS	3	
<b>FSTCW</b> <i>Store FPU Mode Control Register</i>				
	(9B)D9 [mod 111 r/m]	Wait Memory <--- Control Mode Register	1	2
<b>FNSTCW</b> <i>Store FPU Mode Control Register</i>				
	D9 [mod 111 r/m]	Memory <--- Control Mode Register	1	2
<b>FSTENV</b> <i>Store FPU Environment</i>				
	(9B)D9 [mod 110 r/m]	Wait Memory <--- Env. Registers	1	2
<b>FNSTENV</b> <i>Store FPU Environment</i>				
	D9 [mod 110 r/m]	Memory <--- Env. Registers	1	2
<b>FSTSW</b> <i>Store FPU Status Register</i>				
	(9B)DD [mod 111 r/m]	Wait Memory <--- Status Register	1	2
<b>FNSTSW</b> <i>Store FPU Status Register</i>				
	DD [mod 111 r/m]	Memory <--- Status Register	1	2
<b>FSTSW AX</b> <i>Store FPU Status Register to AX</i>				
	(9B)DF E0	Wait AX <--- Status Register	1	2
<b>FNSTSW AX</b> <i>Store FPU Status Register to AX</i>				
	DF E0	AX <--- Status Register	1	2
<b>FSUB</b> <i>Floating Point Subtract</i>				
Top of Stack	DC [1110 1 n]	ST(n) <--- ST(n) - TOS	1/6	
80-bit Register	D8 [1110 0 n]	TOS <--- TOS - ST(n)	1/6	
64-bit Real	DC [mod 100 r/m]	TOS <--- TOS - M.DR	1/6	
32-bit Real	D8 [mod 100 r/m]	TOS <--- TOS - M.SR	1/6	
<b>FSUBP</b> <i>Floating Point Subtract, Pop</i>				
	DE [1110 1 n]	ST(n) <--- ST(n) - TOS; then pop TOS	1/6	
<b>FSUBR</b> <i>Floating Point Subtract Reverse</i>				
Top of Stack	DC [1110 0 n]	TOS <--- ST(n) - TOS	1/6	
80-bit Register	D8 [1110 1 n]	ST(n) <--- TOS - ST(n)	1/6	
64-bit Real	DC [mod 101 r/m]	TOS <--- M.DR - TOS	1/6	
32-bit Real	D8 [mod 101 r/m]	TOS <--- M.SR - TOS	1/6	
<b>FSUBRP</b> <i>Floating Point Subtract Reverse, Pop</i>				
	DE [1110 0 n]	ST(n) <--- TOS - ST(n); then pop TOS	1/6	

Table 8-29. FPU Instruction Set (Continued)

FPU Instruction	Opcode	Operation	Clock Ct Single/DbI (or extended)	Notes
<b>FISUB</b> <i>Floating Point Integer Subtract</i>				
32-bit Integer	DA [mod 100 r/m]	TOS <--- TOS - M.SI	2/7	
16-bit Integer	DE [mod 100 r/m]	TOS <--- TOS - M.WI	2/7	
<b>FISUBR</b> <i>Floating Point Integer Subtract Reverse</i>				
32-bit Integer Reversed	DA [mod 101 r/m]	TOS <--- M.SI - TOS	2/7	
16-bit Integer Reversed	DE [mod 101 r/m]	TOS <--- M.WI - TOS	2/7	
<b>FTST</b> <i>Test Top of Stack</i>				
	D9 E4	CC set by TOS - 0.0	1	
<b>FUCOM</b> <i>Unordered Compare</i>				
	DD [1110 0 n]	CC set by TOS - ST(n)	1/6	
<b>FUCOMP</b> <i>Unordered Compare, Pop</i>				
	DD [1110 1 n]	CC set by TOS - ST(n); then pop TOS	1/6	
<b>FUCOMPP</b> <i>Unordered Compare, Pop two elements</i>				
	DA E9	CC set by TOS - ST(l); then pop TOS and ST(1)	1/6	
<b>FWAIT</b> <i>Wait</i>				
	9B	Wait for FPU not busy	1+	2
<b>FXAM</b> <i>Report Class of Operand</i>				
	D9 E5	CC <--- Class of TOS	1	3
<b>FXCH</b> <i>Exchange Register with TOS</i>				
	D9 [1100 1 n]	TOS <--> ST(n) Exchange	1	3
<b>FXTRACT</b> <i>Extract Exponent</i>				
	D9 F4	temp <--- TOS; TOS <--- exponent (temp); then push significant (temp) onto stack	3/6	
<b>FLY2X</b> <i>Function Eval. <math>y \times \text{Log}_2(x)</math></i>				
	D9 F1	ST(1) <--- ST(1) $\times \text{Log}_2(\text{TOS})$ ; then pop TOS	204 - 222	
<b>FLY2XP1</b> <i>Function Eval. <math>y \times \text{Log}_2(x+1)</math></i>				
	D9 F9	ST(1) <--- ST(1) $\times \text{Log}_2(1+\text{TOS})$ ; then pop TOS	220	4

All references to TOS and ST(n) refer to stack layout prior to execution. Values popped off the stack are discarded. A POP from the stack increments the top of stack pointer. A PUSH to the stack decrements the top of stack pointer. Issues:

- For FCOS, FSIN, FSINCOS, and FPTAN, time shown is for the absolute value of  $\text{TOS} < \pi/4$ :
  - If FSINCOS is outside this range, add two times the FPREM clock counts for argument reduction
  - If FCOS, FSIN, or FPTAN is outside this range, add FPREM clock counts for argument reduction
- These instructions must wait for the FPU pipeline to flush. Cycle count depends on what instructions are in the pipeline.
- These instructions are executed in a separate unit and execute in parallel with other multicycle instructions.
- The AMD Geode LX processor performs PFRCP and PFRSQRT to 24-bit accuracy in one cycle, so these instructions are unnecessary. They are treated as a move.
5. The following opcodes are reserved: D9D7, D9E2, D9E7, DDFC, DED8, DEDA, DEDC, DEDD, DEDE, and DFFC. If a reserved opcode is executed, unpredictable results may occur (exceptions are not generated).

**Table 8-30. AMD 3DNow!™ Technology Instruction Set**

AMD 3DNow!™ Instructions	Opcode/imm8	Operation	Clk Cnt	Notes
<b>FEMMS</b> <i>Faster Exit of the MMX or 3DNow! State</i>	0F0E	Tag Word <--- FFFFh (empties the floating point tag word) MMX registers <--- undefined value	1	1
<b>PAVGUSB</b> <i>Average of Unsigned Packed 8-Bit Values</i>			2	
MMX Register 1 with MMX Register2	0F0F [11 mm1 mm2] BF	MMX reg 1 [byte] <--- rounded up --- (MMX reg 1 [byte] + MMX reg 2 [byte] + 01h)/2		
MMX Register with Memory64	0F0F [mod mm r/m] BF	MMX reg [byte] <--- rounded up --- (MMX reg 1 [byte] + Memory [byte] + 01h)/2		
<b>PF2ID</b> <i>Converts Packed Floating-Point Operand to Packed 32-Bit Integer</i>			2	
MMX Register 1 by MMX Register2	0F0F [11 mm1 mm2] 1D	MMX reg 1 [dword] <--- Sat integer --- MMX reg 2 [dword]		
MMX Register 1 by Memory64	0F0F [mod mm r/m] 1D	MMX reg 1 [dword] <--- Sat integer --- Memory64 [dword]		
<b>PF2IW</b> <i>Packed Floating-Point to Integer Word Conversion with Sign Extend</i>			2	
MMX Register1 by MMX Register2	0F0F [11 mm1 mm2] 1C	MMX reg 1 [dword] <--- integer sign extended --- sat --- MMX reg 2 [dword]		
MMX Register by Memory64	0F0F [mod mm r/m] 1C	MMX reg [dword] <--- integer sign extended --- sat --- Memory64 [dword]		
<b>PFAAC</b> <i>Floating-Point Accumulate</i>			2	
MMX Register 1 with MMX Register2	0F0F [11 mm1 mm2] AE	MMX reg 1 [low dword] <--- MMX reg 1 [low dword] + MMX reg 1 [high dword] MMX reg 1 [high dword] <--- MMX reg 2 [low dword] + MMX reg 2 [high dword]		
MMX Register 1 with Memory64	0F0F [mod mm r/m] AE	MMX reg 1 [low dword] <--- MMX reg 1 [low dword] + MMX reg 1 [high dword] MMX reg 1 [high dword] <--- Memory64 [low dword] + Memory64 [high dword]		
<b>PFADD</b> <i>Packed Floating-Point Addition</i>			2	
MMX Register1 with MMX Register2	0F0F [11 mm1 mm2] 9E	MMX reg 1 [dword] <--- MMX reg 1 [dword] + MMX reg 2 [dword]		
MMX Register1 with Memory64	0F0F [mod mm r/m] 9E	MMX reg 1 [dword] <--- MMX reg 1 [dword] + Memory64 [dword]		
<b>PFCMPEQ</b> <i>Packed Floating-Point Comparison, Equal to</i>			2	
MMX Register 1 with MMX Register 2	0F0F [11 mm1 mm2] B0	MMX reg 1 [dword] <--- FFFF FFFFh --- if (MMX reg 1 [dword] = MMX reg 2 [dword]) MMX [dword] <--- 0000 0000h --- if (MMX reg 1 [dword] NOT = MMX reg 2 [dword])		
MMX Register with Memory64	0F0F [mod mm r/m] B0	MMX reg [dword] <--- FFFF FFFFh --- if (MMX reg [dword] = Memory64 [dword]) MMX reg [dword] <--- 0000 0000h --- if (MMX reg [dword] NOT = Memory64 [dword])		
<b>PFCMPGE</b> <i>Packed Floating-Point Comparison, Greater Than or Equal to</i>			2	
MMX Register 1 with MMX Register2	0F0F [11 mm1 mm2] 90	MMX reg 1 [dword] <--- FFFF FFFFh --- if (MMX reg 1 [dword] ≥ MMX reg 2 [dword]) MMX reg 1 [dword] <--- 0000 0000h --- if (MMX reg 1 [dword] NOT ≥ MMX reg 2 [dword])		
MMX Register with Memory64	0F0F [mod mm r/m] 90	MMX reg 1 [dword] <--- FFFF FFFFh --- if (MMX reg 1 [dword] ≥ Memory64 [dword]) MMX reg [dword] <--- 0000 0000h --- if (MMX reg [dword] NOT ≥ Memory64 [dword])		
<b>PFCMPGT</b> <i>Packed Floating-Point Comparison, Greater Than</i>			2	
MMX Register1 with MMX Register2	0F0F [11 mm1 mm2] A0	MMX reg 1 [dword] <--- FFFF FFFFh --- if (MMX reg 1 [dword] > MMX reg 2 [dword]) MMX reg 1 [dword] <--- 0000 0000h --- if (MMX reg 1 [dword] NOT > MMX reg 2 [dword])		
MMX Register with Memory64	0F0F [mod mm r/m] A0	MMX reg [dword] <--- FFFF FFFFh --- if (MMX reg [dword] > Memory64 [dword]) MMX reg [dword] <--- 0000 0000h --- if (MMX reg [dword] NOT > Memory64 [dword])		

Table 8-30. AMD 3DNow!™ Technology Instruction Set (Continued)

AMD 3DNow!™ Instructions	Opcode/imm8	Operation	Clk Cnt	Notes
<b>PFMAX Packed Floating-Point MAXimum</b>			2	
MMX Register1 with MMX Register2	0F0F [11 mm1 mm2] A4	MMX reg 1[dword] <--- MMX reg 1 [dword] --- if (MMX reg 1 [dword] > MMX reg 2 [dword]) MMX reg 1 [dword] <--- MMX reg 2 [dword] --- if (MMX reg 1 [dword] NOT > MMX reg 2 [dword])		
MMX Register with Memory64	0F0F [mod mm r/m] A4	MMX reg [dword] <--- MMX reg [dword] --- if (MMX reg [dword] > Memory64 [dword]) MMX reg [dword] <--- Memory [dword] --- if (MMX reg [dword] NOT > Memory64 [dword])		
<b>PFMIN Packed Floating - Point MINimum</b>			2	
MMX Register 1 with MMX Register2	0F0F [11 mm1 mm2] 94	MMX reg 1 [dword] <--- MMX reg 1 [dword] --- if (MMX reg 1 [dword] < MMX reg 2 [dword]) MMX reg 1 [dword] <--- MMX reg 1 [dword] --- if (MMX reg 1 [dword] NOT < MMX reg 2 [dword])		
MMX register1 with Mwnory64	0F0F [mod mm r/m] 94	MMX reg [dword] <--- MMX reg [dword] --- if (MMX reg [dword] < Memory64 [dword]) MMX reg [dword] <--- Memory64 [dword] --- if (MMX reg [dword] NOT < Memory64 [dword])		
<b>PFMUL Packed Floating-Point Multiplication</b>			2	
MMX Register 1 with MMX Register 2	0F0F [11 mm1 mm2] B4	MMX reg 1 [dword] <--- sat --- MMX reg 1 [dword] * MMX reg 2 [dword]		
MMX Register with Memory64	0F0F [mod mm 2] B4	MMX reg [dword] <--- sat --- MMX reg [dword] * Memory64 [dword]		
<b>PFNACC Packed Floating-Point Negative Accumulate</b>			2	
MMX Register1 with MMX Register2	0F0F [11 mm1 mm2] 8A	MMX reg 1 [low dword] <--- (MMX reg 1 [low dword] - MMX reg 1 [high dword]) MMX reg 1 [high dword] <--- (MMX reg 2 [low dword] - MMX reg 2 [high dword])		
MMX Register with Memory64	0F0F [mod mm r/m] 8A	MMX reg [low dword] <--- (MMX reg [low dword] - MMX reg [high dword]) MMX reg [high dword] <--- (Memory64 [low dword] - Memory64 [high dword])		
<b>PFPNACC Packed Floating-Point Mixed Positive-Negative Accumulate</b>			2	
MMX Register1 with MMX Register2	0F0F [11 mm1 mm2] 8E	MMX reg 1 [low dword] <--- (MMX reg 1 [low dword] - MMX reg 1 [high dword]) MMX reg 1 [high dword] <--- (MMX reg 2 [low dword] + MMX reg 2 [high dword])		
MMX Register with Memory64	0F0F [mod mm r/m] 8E	MMX reg [low dword] <--- (MMX reg [low dword] - MMX reg [low dword]) MMX reg [high dword] <--- (Memory64 [low dword] - Memory64 [high dword])		
<b>PFRCPP Floating-Point Reciprocal Approximation</b>			2	1
MMX Register1 with MMX Register2	0F0F [11 mm1 mm2] 96	MMX reg 1 [low dword] <--- sat --- reciprocal --- MMX reg 2 [low dword] MMX reg 1 [high dword] <--- sat --- reciprocal --- MMX reg 2 [low dword]		
MMX Register with Memory64	0F0F [mod mm r/m] 96	MMX reg [Low dword] <--- sat --- reciprocal --- Memory64 [low dword] MMX reg [high dword] <--- sat --- reciprocal --- Memory64 [low dword]		
<b>PFRCPPV Floating-Point Reciprocal Vector</b>			2	3
MMX Register1 with MMX Register	0F0F [11 mm1 mm2] 86	MMX reg 1 [low dword] <---sat --- reciprocal --- MMX reg 2 [low dword] MMX reg 1 [high dword] <--- sat --- reciprocal MMX reg 2 [high dword]		
MMX Register with Memory64	0F0F [mod mm r/m] 86	MMX reg [low dword] <---sat --- reciprocal Value - Memory64 [low dword] MMX reg [high dword] <--- sat --- reciprocal value - Memory64 [high dword]		
<b>PFRCPIT1 Packed Floating-Point Reciprocal, First Iteration Step</b>			1	1, 2
MMX Register1 with MMX Register 2	0F0F [11 mm1 mm2] A6	MMX reg 1 [dword] <--- move --- MMX reg 2 [dword]		
MMX Register with Memory64	0F0F [mod mm r/m] A6	MMX reg [dword] <--- move --- Memory64 [dword]		
<b>PFRCPIT2 Packed Floating-Point Reciprocal/Reciprocal Square Root, Second Iteration Step</b>			1	1, 2
MMX Register 1 with MMX Register 2	0FDF [11 mm1 mm2] B6	MMX reg 1 [dword] <--- move --- MMX reg 2 [dword]		
MMX Register with Memory64	0FDF [mod mm r/m] B6	MMX reg [dword] <--- move --- Memory64 [dword]		



**Table 8-30. AMD 3DNow!™ Technology Instruction Set (Continued)**

AMD 3DNow!™ Instructions	Opcode/imm8	Operation	Clk Cnt	Notes
<b>PFSRQIT1</b> <i>Packed Floating-Point Reciprocal Square Root, First Iteration Step</i>			1	1, 2
MMX Register1 with MMX Register 2	0F0F [11 mm1 mm2] A7	MMX reg 1 [dword] <--- move --- MMX reg 2 [dword]		
MMX Register with Memory64	0F0F [mod mm r/m] A7	MMX reg [dword] <--- move --- Memory64 [dword]		
<b>PFRSQRT</b> <i>Floating-Point Reciprocal Square Root</i>			2	
MMX Register 1 by MMX Register 2	0F0F [11 mm1 mm2] 97	MMX reg.1 [low dword] <--- reciprocal --- square root --- MMX reg 2 [low dword] MMX reg 2 [high dword] <--- reciprocal --- square root --- MMX reg 2 [low dword]		
MMX Register by Memory64	0F0F [mod mm r/m] 97	MMX reg [low dword] <--- reciprocal --- square root --- Memory64 [low dword] MMX reg [high word] <--- reciprocal --- square root --- Memory64 [low dword]		
<b>PFRSQRTV</b> <i>Floating-Point Reciprocal Square Root Vector</i>			2	3
MMX Register1 with MMX Register2	0F0F [11 mm1 mm2] 87	MMX reg 1 [low dword] <--- sat --- reciprocal --- square root --- MMX reg 2 [low dword] MMX reg 1 [high word] <--- sat --- reciprocal --- square root --- MMX reg 2 [high dword]		
MMX Register with Memory64	0F0F [mod mm r/m] 87	MMX reg [low dword] <---sat --- reciprocal --- square root --- Memory64 [low dword] MMX reg [high dword] <--- sat --- reciprocal --- square root --- Memory64 [high dword]		
<b>PFSUB</b> <i>Packed Floating- Point Subtraction</i>			2	
MMX Register1 with MMX Register2	0F0F [11 mm1 mm2] 9A	MMX reg 1 [dword] <--- (MMX reg1 [dword] - MMX reg 2 [dword])		
MMX Register with MMX Memory64	0F0F [mod mm r/m] 9A	MMX reg [dword] <--- (MMX reg [dword] - Memory64 [dword])		
<b>PFSUBR</b> <i>Packed Floating-Point Reverse Subtraction</i>			2	
MMX Register1 with MMX Register2	0F0F [11mm1 mm2] AA	MMX reg 1 [dword] <---(MMX reg 2 [dword] - MMX reg [dword])		
MMX Register with Memory64	0F0F [mod mm r/m] AA	MMX REG [dword] <--- (Memory64 [dword] - MMX reg [dword])		
<b>PI2FD</b> <i>Packed 32-Bit Integer to Floating-Point Conversion</i>			2	
MMX Register1 by MMX Register2	0F0F [11 mm1 mm2] 0D	MMX reg 1 [dword] <--- trun --- float --- MMX reg 2 [dword]		
MMX Register by Memory64	0F0F [mod mm r/m] 0D	MMX reg [dword] <--- trun --- float --- Memory64 [dword]		
<b>PIF2W</b> <i>Packed Integer Word to Floating-Point Conversion</i>			2	
MMX Register1 by MMX Register2	0F0F [11 mm1 mm2] 0C	MMX reg 1 [low dword] <--- float --- MMX reg 2 [low word (low dword)] MMX reg 1 [high dword] <--- float --- MMX reg 2 [low word (high dword)]		
MMX Register by Memory64	0F0F [mod mm r/m] 0C	MMX reg [low dword] <--- float --- Memory64 [low word (low dword)] MMX reg [high dword] <--- float --- Memory64 [low word (high dword)]		
<b>PMULHRW</b> <i>Multiply Signed Packed 16-bit Value with Rounding and Store the High 16 bits</i>			2	
MMX Register1 with MMX Register2	0F0F [11 mm1 mm2] B7	MMX reg 1 [word] <--- (MMX reg 1 [word] * MMX reg 2 [word]) + 8000h		
MMX Register with Memory64	0F0F [mod mm r/m] B7	MMX reg [word] <--- (MMX reg [word] * Memory64 [word]) + 8000h		
<b>PREFETCH/PREFETCHW</b> <i>Prefetch Cache Line into L1 Data Cache (Dcache)</i>				
Memory 8	0F0D			
<b>PSWAPD</b> <i>Packed Swap Doubleword</i>			1	
MMX Register1 by MMX Register2	0F0F [11 mm1 mm2] BB	MMX reg 1 [low dword] <--- MMX reg 2 [high dword] MMX reg 1 [high dword] <--- MMX reg 2 [low dword]		
MMX Register by Memory64	0F0F [mod mm r/m] BB	MMX reg [low dword] <--- Memory64 [high dword] MMX reg [high dword] <--- Memory64 [low dword]		

- 1) These instructions must wait for the FPU pipeline to flush. Cycle count depends on what instructions are in the pipeline.
- 2) The AMD Geode LX processor performs PFRCP and PFRSQRT to 24-bit accuracy in one cycle, so these instructions are unnecessary. They are treated as a move.
- 3) Non-standard AMD 3DNow! instruction. See Section 8.4.1 on page 674 for details.

## 8.4.1 Non-Standard AMD 3DNow!™ Technology Instructions

### 8.4.1.1 PFRCPV - Floating-Point Reciprocal Approximation

Opcode	Instruction	Clocks	Description
0F 0F / 86	PFRCPV <i>xr,xr/m64</i>	2	Approximate reciprocal

#### Operation

```
DEST[31:0] <= reciprocal(SRC[31:0]);
DEST[63:32] <= RECIPROCAL(SRC[63:32]);
```

#### Description

PFRCPV performs the same operation as the PFRCP instruction except that PFRCPV operates on both halves of its operands, while PFRCP operates on only bits [31:0] of its operand.

#### Flags Affected

None.

#### Exceptions

#GP(0) If a memory operand is illegal and not in SS.  
 #SS(0) If memory operand is illegal and in SS.  
 #PF(code) Page fault.  
 #AC Unaligned access.  
 #UD Illegal opcode.

#### Notes

This instruction is enabled by the INV\_3DNOW\_ENABLE bit (bit 1) of the ID\_CONFIG MSR (MSR 00001250h).

### 8.4.1.2 PFRSQRTV - Floating-Point Reciprocal Square Root Approximation

Opcode	Instruction	Clocks	Description
0F 0F / 87	PFRSQRTV <i>xr,xr/m64</i>	2	Approximate reciprocal square root

#### Operation

```
DEST[31:0] <= reciprocal_SQUARE_ROOT(SRC[31:0]);
DEST[63:32] <= RECIPROCAL_SQUARE_ROOT(SRC[63:32]);
```

#### Description

PFRSQRTV performs the same operation as the PFRSQRT instruction except that PFRSQRTV operates on both halves of its operands, while PFRSQRT operates on only bits [31:0] of its operand.

#### Flags Affected

None.

#### Exceptions

#GP(0) If a memory operand is illegal and not in SS.  
 #SS(0) If memory operand is illegal and in SS.  
 #PF(code) Page fault.  
 #AC Unaligned access.  
 #UD Illegal opcode.

#### Notes

This instruction is enabled by the INV\_3DNOW\_ENABLE bit (bit 1) of the ID\_CONFIG MSR (MSR 00001250h).

# Package Specifications



## 9.1 Physical Dimensions

The figures in this section provide the mechanical package outline for the BGU481 (481-terminal Ball Grid Array Cavity Up)

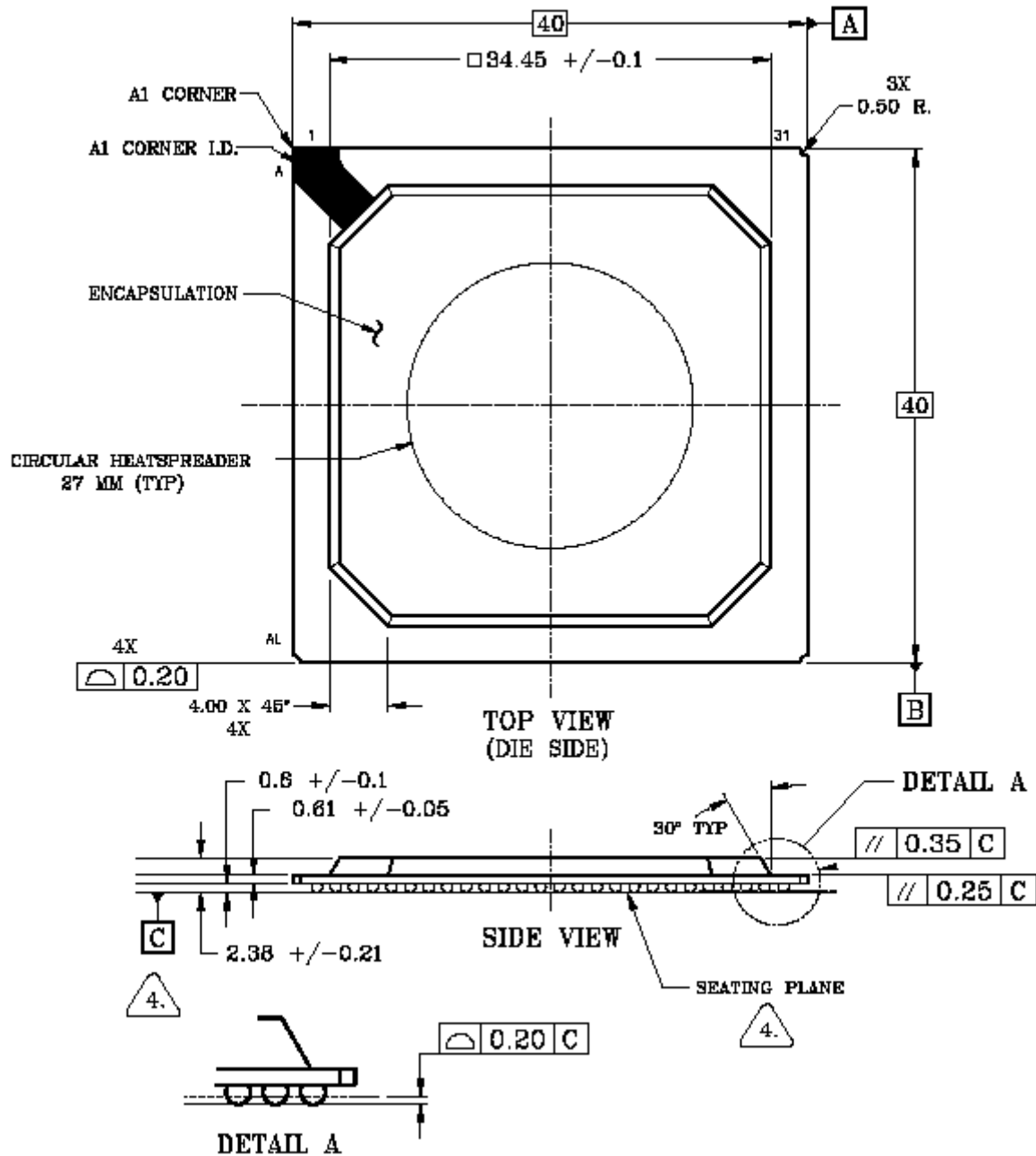
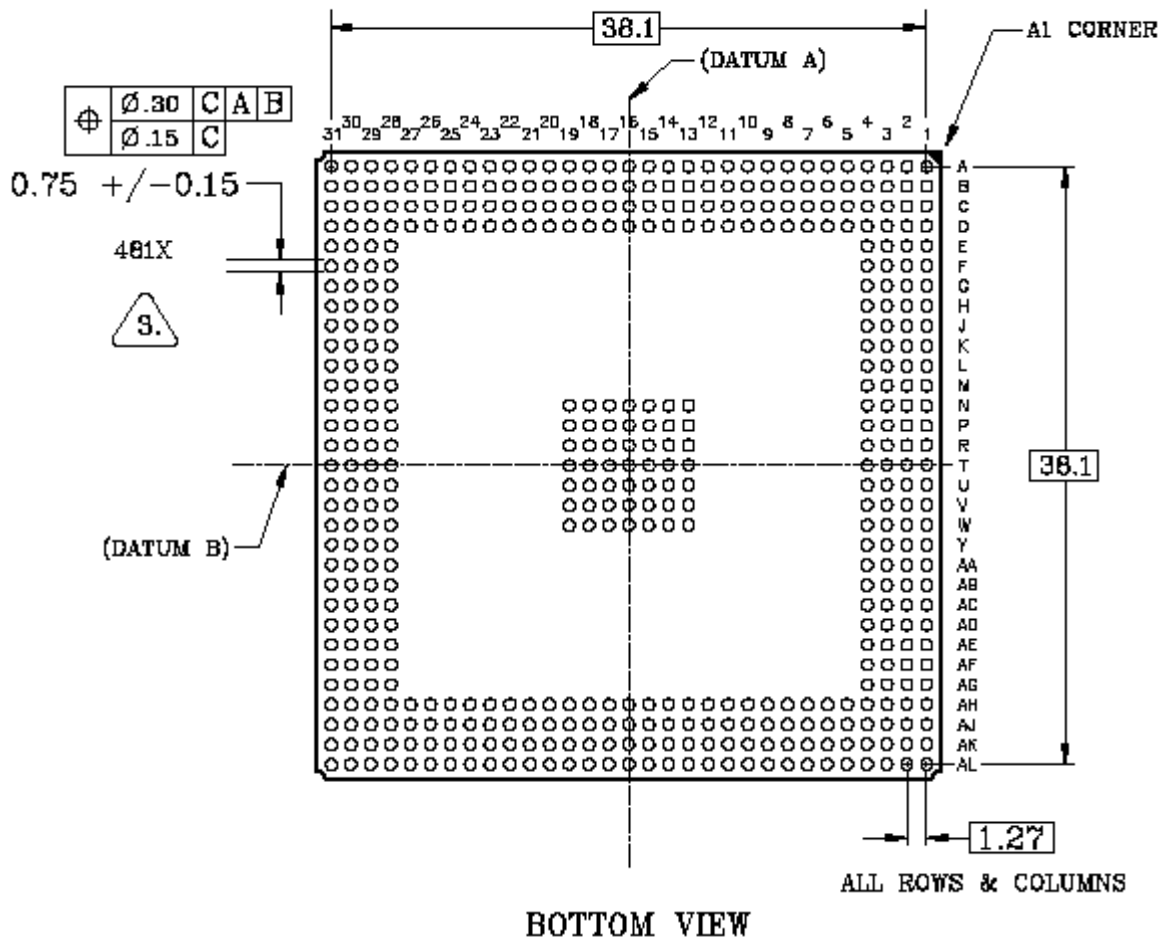


Figure 9-1. BGU481 Top/Side View/Dimensions



NOTES

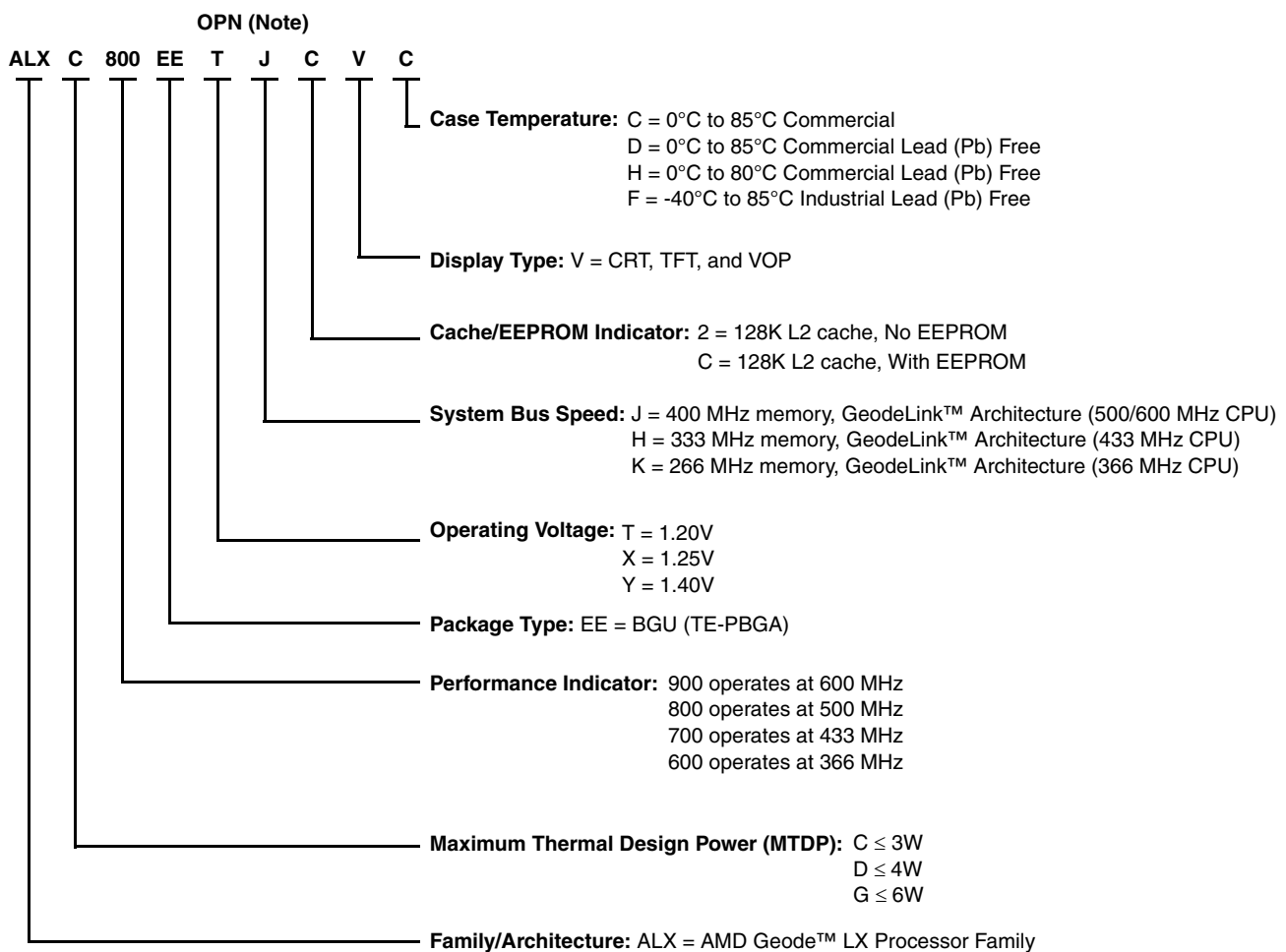
1. DIMENSIONING AND TOLERANCING PER ASME Y14.5M-1994 .
2. ALL DIMENSIONS ARE IN MILLIMETERS .
3. MEASURED AT MAXIMUM SOLDER BALL DIAMETER ON A PLANE PARALLEL TO DATUM C.
4. DATUM C AND SEATING PLANE ARE DEFINED BY THE SPHERICAL CROWNS OF THE SOLDER BALLS.
5. CONFORMS TO JEP-95, MS-034, VARIATION BAU-1.

Figure 9-2. BGU481 Bottom View/Dimensions

# Support Documentation

## A.1 Order Information

Ordering information for the AMD Geode™ LX processors is contained in this section. The ordering part number (OPN) is formed by a combination of elements. An example of the OPN is shown in Figure A-1. Valid OPN combinations are provided in Table A-1 on page 678.



**Note:** Spaces are added to the ordering number shown above for viewing clarity only.

**Figure A-1. AMD Geode™ LX Processors OPN Example**

**Table A-1. Valid OPN Combinations**

Family Architecture	MTDP	Performance Indicator	Package Type	Operating Voltage	System Bus Speed	EEPROM Indicator	Display Type	Case Temperature/ Solder Type (Note)
ALX	G	900	EE	Y	J	2	V	H
ALX	D	800	EE	X	J	2	V	C
								D
								F
						C		C
								D
ALX	C	700	EE	T	H	2	V	C
								D
						C		C
								D
ALX	C	600	EE	T	K	2	V	D

**Note:**  $\theta_{JC} = 3.7^{\circ} \text{C/W}$

Consult your local AMD sales office to confirm availability of specific valid combinations and to check on newly released combinations possibly not listed.

## A.2 Data Book Revision History

This document is a report of the revision/creation process of the data book for the AMD Geode™ LX processors. Any revision (i.e., additions, deletions, parameter corrections, etc.) are recorded in the table(s) below.

**Table A-2. Revision History**

Revision # (PDF Date)	Revisions / Comments
0.1 (April 2004)	Advance Information.
0.5 (September 2004)	Added data registers descriptions, electrical specifications, and package specification sections. Still preliminary and in the review/proofing process.
0.9 (January 2005)	Added functional descriptions and other corrections.
A (May 2005)	Engineering edits.
B (October 2005)	Majority of edits to Electrical section.
C (April 2006)	Engineering edits.
D (June 2006)	Engineering edits.
E (November 2006)	Added LX 900@1.5W processor values and other clarification edits/corrections.
F (May 2007)	Added industrial temperature values and other minor edits/corrections.
G (May 2008)	Minor edits/corrections. See Table A-3 for details.
H (February 2009)	Added LX 600@0.7W parameters.

**Table A-3. Edits to Current Revision**

Section	Revision
<b>Section 1.0 "Overview"</b>	<ul style="list-style-type: none"> <li>Section 1.1 "General Description" on page 11:               <ul style="list-style-type: none"> <li>Updated link to AMD Embedded Developer Support Web site.</li> </ul> </li> <li>Section 1.2 "Features" on page 12:               <ul style="list-style-type: none"> <li>Added LX 600@0.7W to Power Management bullet and footnote.</li> </ul> </li> </ul>
<b>Section 6.2 "GeodeLink™ Memory Controller Register Descriptions"</b>	<ul style="list-style-type: none"> <li>Section 6.2.2.11 "Feature Enables (MC_CF1017_DATA)" on page 231:               <ul style="list-style-type: none"> <li>Slightly modified WR2DAT bit description.</li> </ul> </li> </ul>
<b>Section 7.0 "Electrical Specifications"</b>	<ul style="list-style-type: none"> <li>Table 7-2 "Operating Conditions" on page 598:               <ul style="list-style-type: none"> <li>Added LX 600@0.7W and DDR2 values.</li> </ul> </li> <li>Table 7-3 "AMD Geode LX 900@1.5W Processor DC Currents" on page 600, Table 7-4 "AMD Geode LX 800@0.9W Processor DC Currents" on page 601, and Table 7-5 "AMD Geode LX 700@0.8W Processor DC Currents" on page 602:               <ul style="list-style-type: none"> <li>Added I<sub>MEMDDR2ON</sub> parameter and values.</li> </ul> </li> <li>Table 7-6 "AMD Geode LX 600@0.7W Processor DC Currents" on page 603:               <ul style="list-style-type: none"> <li>New table.</li> </ul> </li> </ul>
<b>Section A.1 "Order Information"</b>	<ul style="list-style-type: none"> <li>Figure A-1 "AMD Geode™ LX Processors OPN Example" on page 677:               <ul style="list-style-type: none"> <li>Added "K" to System Bus Speed and "600" to Performance Indicator.</li> </ul> </li> <li>Table A-1 "Valid OPN Combinations" on page 678:               <ul style="list-style-type: none"> <li>Added LX 600@0.7W OPN.</li> </ul> </li> </ul>



[www.amd.com](http://www.amd.com)



## X-ON Electronics

Largest Supplier of Electrical and Electronic Components

*Click to view similar products for [Microprocessors - MPU category](#):*

*Click to view products by [Cypress manufacturer](#):*

Other Similar products are found below :

[MC68302EH20C](#) [MC7457RX1000LC](#) [MC7457RX1267LC](#) [MC7457VG1267LC](#) [A2C00010998 A](#) [A2C52004004](#) [R5F117BCGNA#20](#)  
[R5F52106BDLA#U0](#) [R5S72690W266BG#U0](#) [ADJ3400IAA5DOE](#) [MPC8245TVV266D](#) [MPC8245TZU300D](#) [MPC8260ACVVMHBB](#)  
[MPC8323ECVRAFDCA](#) [MPC8323VRADDCA](#) [MPC8536ECVJAVLA](#) [BOXNUC5PGYH0AJ](#) [20-668-0024](#) [P1010NSN5DFB](#)  
[P2010NSE2KHC](#) [P2010NSN2MHC](#) [P2020NXE2HHC](#) [P5020NSE7QMB](#) [P5020NSE7TNB](#) [P5020NSE7VNB](#) [LS1020ASN7KQB](#)  
[LS1020AXN7HNB](#) [LS1020AXN7KQB](#) [A2C00010729 A](#) [A2C00039344](#) [T1022NSE7MQB](#) [T1022NXN7PQB](#) [T1023NSE7MQA](#)  
[T1024NXE7PQA](#) [T1042NSE7MQB](#) [T1042NSN7MQB](#) [T1042NXN7WQB](#) [T2080NSE8TTB](#) [T2080NSN8PTB](#) [T2080NXE8TTB](#)  
[T2081NXN8TTB](#) [R5F101AFASP#V0](#) [MC68302CEH20C](#) [TS68040MF33A](#) [MPC8260ACVVMIBB](#) [MPC8280CZUUPEA](#)  
[MPC8313ECVRAFFC](#) [MPC8313ECVRAGDC](#) [MPC8313EVRADDC](#) [MPC8313EVRAFFC](#)