



The following document contains information on Cypress products. Although the document is marked with the name “Broadcom”, the company that originally developed the specification, Cypress will continue to offer these products to new and existing customers.

CONTINUITY OF SPECIFICATIONS

There is no change to this document as a result of offering the device as a Cypress product. Any changes that have been made are the result of normal document improvements and are noted in the document history page, where supported. Future revisions will occur when appropriate, and changes will be noted in a document history page.

CONTINUITY OF ORDERING PART NUMBERS

Cypress continues to support existing part numbers. To order these products, please use only the Ordering Part Numbers listed in this document.

FOR MORE INFORMATION

Please visit our website at www.cypress.com or contact your [local sales office](#) for additional information about Cypress products and services.

OUR CUSTOMERS

Cypress is for true innovators – in companies both large and small.

Our customers are smart, aggressive, out-of-the-box thinkers who design and develop game-changing products that revolutionize their industries or create new industries with products and solutions that nobody ever thought of before.

ABOUT CYPRESS

Founded in 1982, Cypress is the leader in advanced embedded system solutions for the world’s most innovative automotive, industrial, home automation and appliances, consumer electronics and medical products. Cypress’s programmable systems-on-chip, general-purpose microcontrollers, analog ICs, wireless and USB-based connectivity solutions and reliable, high-performance memories help engineers design differentiated products and get them to market first.

Cypress is committed to providing customers with the best support and engineering resources on the planet enabling innovators and out-of-the-box thinkers to disrupt markets and create new product categories in record time. To learn more, go to www.cypress.com.



Single-Chip Bluetooth Low Energy-Only System-On-Chip with Support for Wireless Charging

GENERAL DESCRIPTION

The Broadcom® BCM20737 is an advanced Bluetooth low energy (aka Bluetooth Smart) SoC that supports wireless charging, includes advanced security features and introduces new software support for NFC pairing. The BCM20737 is designed to support the entire spectrum of Bluetooth Smart use cases for the medical, home automation, accessory, sensor, Internet Of Things, and wearable market segments.

The BCM20737 radio has been designed to provide low power, low cost, and robust communications for applications operating in the globally available 2.4 GHz unlicensed Industrial, Scientific, and Medical (ISM) band.

The single-chip Bluetooth low energy SoC is a monolithic component implemented in a standard digital CMOS process and requires minimal external components to make a fully compliant Bluetooth device. The BCM20737 is available in a 32-pin, 5 mm × 5 mm 32-QFN package as well as WLBGA SIP and die packages.

APPLICATIONS

The following profiles are supported^a in ROM:

- Battery status
- Blood pressure monitor
- Find me
- Heart rate monitor
- Proximity
- Thermometer
- Weight scale
- Time

Additional profiles that can be supported^a from RAM include:

- Blood glucose monitor
- Temperature alarm
- Location

a. Full qualification and use of these profiles may require FW updates from Broadcom. Some of these profiles are under development/approval at the Bluetooth SIG and conformity with the final approved version is pending. Contact your supplier for updates and the latest list of profiles.

FEATURES

- Alliance for Wireless Power (A4WP) wireless charging
- Support for RSA encryption/decryption and key exchange mechanisms (up to 4 kbit)
- Support for X.509 certificate exchange
- Support for NFC tag-based "tap-to-pair"
- Support for Bluetooth Smart Based Audio
- Bluetooth low energy (BLE)-compliant
- Infrared modulator
- IR learning
- Supports Adaptive Frequency Hopping
- Excellent receiver sensitivity
- 10-bit auxiliary ADC with nine analog channels
- On-chip support for serial peripheral interface (master and slave modes)
- Broadcom Serial Communications interface (compatible with Philips® I²C slaves)
- Programmable output power control
- Integrated ARM® Cortex™-M3 based microprocessor core
- Automation Profile
- Support for secure OTA
- On-chip power-on reset (POR)
- Support for EEPROM and serial flash interfaces
- Integrated low-dropout regulator (LDO)
- On-chip software controlled power management unit
- Package type:
 - 32-pin 32-QFN package (5 mm × 5 mm)
- RoHS compliant

Figure 1: Functional Block Diagram

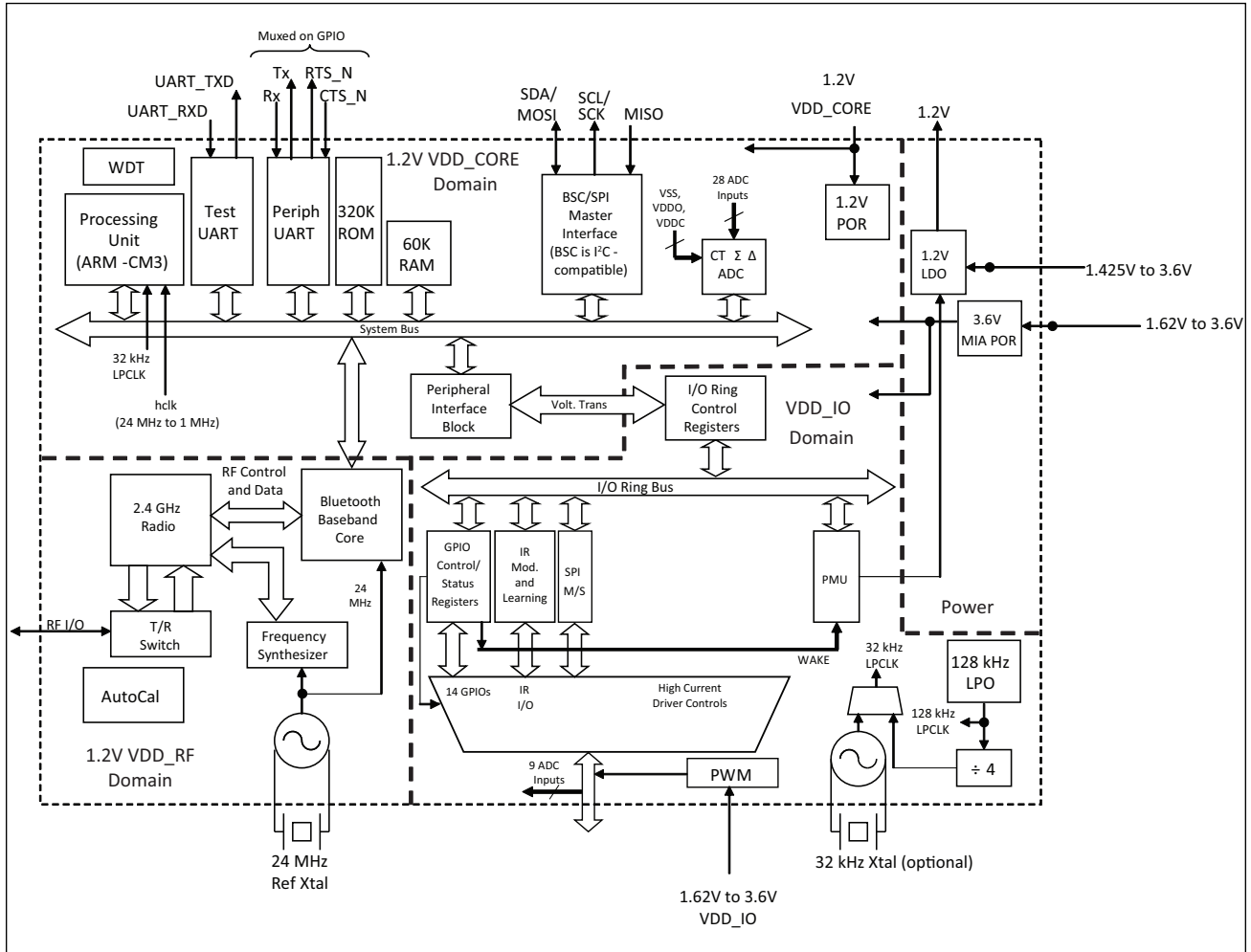

Revision History

Revision	Date	Change Description
20737-DS102-R	08/17/16	Updated: <ul style="list-style-type: none">• “Ordering Information” on page 45
20737-DS101-R	02/10/16	Added: <ul style="list-style-type: none">• “ESD Test Models” on page 42
20737-DS100-R	05/30/14	Initial release.

Broadcom Corporation
5300 California Avenue
Irvine, CA 92617

© 2016 by Broadcom Corporation
All rights reserved
Printed in the U.S.A.

Broadcom®, the pulse logo, Connecting everything®, and the Connecting everything logo are among the trademarks of Broadcom Corporation and/or its affiliates in the United States, certain other countries and/or the EU. Any other trademarks or trade names mentioned are the property of their respective owners.

This data sheet (including, without limitation, the Broadcom component(s) identified herein) is not designed, intended, or certified for use in any military, nuclear, medical, mass transportation, aviation, navigations, pollution control, hazardous substances management, or other high-risk application. BROADCOM PROVIDES THIS DATA SHEET “AS-IS,” WITHOUT WARRANTY OF ANY KIND. BROADCOM DISCLAIMS ALL WARRANTIES, EXPRESSED AND IMPLIED, INCLUDING, WITHOUT LIMITATION, THE IMPLIED WARRANTIES OF MERCHANTABILITY, FITNESS FOR A PARTICULAR PURPOSE, AND NON-INFRINGEMENT.

Table of Contents

About This Document	8
Purpose and Audience	8
Document Conventions	8
Technical Support	8
Section 1: Functional Description	9
Bluetooth Baseband Core	9
Frequency Hopping Generator	9
E0 Encryption	9
Link Control Layer	9
Adaptive Frequency Hopping	9
Bluetooth Low Energy Profiles	10
Test Mode Support	10
Infrared Modulator	11
Infrared Learning	12
Wireless Charging	12
Security	13
Support for NFC Tag Based Pairing	13
Bluetooth Smart Audio	13
ADC Port	14
Serial Peripheral Interface	15
Microprocessor Unit	16
EEPROM Interface	16
Serial Flash Interface	16
Internal Reset	17
External Reset	17
Integrated Radio Transceiver	18
Transmitter Path	18
Digital Modulator	18
Power Amplifier	18
Receiver Path	18
Digital Demodulator and Bit Synchronizer	18
Receiver Signal Strength Indicator	18
Local Oscillator	18
Calibration	19
Internal LDO Regulator	19
Peripheral Transport Unit	19
Broadcom Serial Communications Interface	19

UART Interface.....	20
Clock Frequencies	20
Crystal Oscillator.....	20
Peripheral Block.....	21
32 kHz Crystal Oscillator.....	21
GPIO Port	22
PWM	23
Power Management Unit	24
RF Power Management.....	24
Host Controller Power Management.....	24
BBC Power Management.....	24
Section 2: Pin Assignments	25
Pin Descriptions	25
GPIO Pin Multiplexing	30
Ball Maps	32
Section 3: Specifications	33
Electrical Characteristics	33
RF Specifications	36
Timing and AC Characteristics	38
UART Timing.....	38
SPI Timing.....	39
BSC Interface Timing.....	41
ESD Test Models	42
Human-Body Model (HBM) – ANSI/ESDA/JEDEC JS-001-2012.....	42
Machine Model (MM) – JEDEC JESD22-A115C.....	42
Charged-Device Model (CDM) - JEDEC JESD22-C101E.....	42
Results Summary.....	42
Section 4: Mechanical Information	43
Tape Reel and Packaging Specifications.....	44
Section 5: Ordering Information	45
Appendix A: Acronyms and Abbreviations	46

List of Figures

Figure 1: Functional Block Diagram.....	2
Figure 2: Infrared TX.....	11
Figure 3: Infrared RX	12
Figure 4: Internal Reset Timing.....	17
Figure 5: External Reset Timing	17
Figure 6: Recommended Oscillator Configuration— 12 pF Load Crystal	20
Figure 7: 32 kHz Oscillator Block Diagram	21
Figure 8: PWM Channel Block Diagram	23
Figure 9: 32-pin QFN Ball Map	32
Figure 10: UART Timing	38
Figure 11: SPI Timing – Mode 0 and 2	39
Figure 12: SPI Timing – Mode 1 and 3	40
Figure 13: BSC Interface Timing Diagram.....	41
Figure 14: 32-pin QFN	43
Figure 15: Pin 1 Orientation	44

List of Tables

Table 1: ADC Modes.....	14
Table 2: BCM20737 First SPI Set (Master Mode)	15
Table 3: BCM20737 Second SPI Set (Master Mode)	15
Table 4: BCM20737 Second SPI Set (Slave Mode)	15
Table 5: Reference Crystal Electrical Specifications	21
Table 6: XTAL Oscillator Characteristics	22
Table 7: Pin Descriptions	25
Table 8: GPIO Pin Descriptions	27
Table 9: GPIO Pin Multiplexing	30
Table 10: Maximum Electrical Rating	33
Table 11: Power Supply	33
Table 12: LDO Regulator Electrical Specifications	34
Table 13: ADC Specifications	34
Table 14: Digital Levels.....	35
Table 15: Current Consumption	35
Table 16: Power Supply Current Consumption.....	35
Table 17: Receiver RF Specifications.....	36
Table 18: Transmitter RF Specifications	36
Table 19: UART Timing Specifications	38
Table 20: SPI Interface Timing Specifications	39
Table 21: BSC Interface Timing Specifications.....	41
Table 22: BCM20737 5 × 5 × 1 mm QFN, 32-Pin Tape Reel Specifications	44
Table 23: Ordering Information	45

About This Document

Purpose and Audience

This data sheet provides a description of the major blocks, interfaces, pin assignments, and specifications of the BCM20736 single-chip Bluetooth low energy (BLE) SoC. This is a required document for designers responsible for adding the BCM20736 BLE SoC to wireless input device applications including heart-rate monitors, blood-pressure monitors, proximity sensors, temperature sensors, wireless chargers, and battery monitors. Acronyms and Abbreviations

In most cases, acronyms and abbreviations are defined on first use.

Acronyms and abbreviations in this document are also defined in Appendix A: “Acronyms and Abbreviations,” on page 44.

For a comprehensive list of acronyms and other terms used in Broadcom documents, go to: <http://www.broadcom.com/press/glossary.php>.

Document Conventions

The following conventions may be used in this document:

Convention	Description
Bold	User input and actions: for example, type exit , click OK , press Alt+C
Monospace	Code: <code>#include <iostream></code> HTML: <code><td rowspan = 3></code> Command line commands and parameters: <code>w1 [-1] <command></code>
< >	Placeholders for <i>required</i> elements: enter your <code><username></code> or <code>w1 <command></code>
[]	Indicates <i>optional</i> command-line parameters: <code>w1 [-1]</code> Indicates bit and byte ranges (inclusive): <code>[0:3]</code> or <code>[7:0]</code>

Technical Support

Broadcom provides customer access to a wide range of information, including technical documentation, schematic diagrams, product bill of materials, PCB layout information, and software updates through its customer support portal (<https://support.broadcom.com>). For a CSP account, contact your Sales or Engineering support representative.

In addition, Broadcom provides other product support through its Downloads and Support site (<http://www.broadcom.com/support/>).

Section 1: Functional Description

Bluetooth Baseband Core

The Bluetooth Baseband Core (BBC) implements all of the time-critical functions required for high performance Bluetooth operation. The BBC manages the buffering, segmentation, and data routing for all connections. It also buffers data that passes through it, handles data flow control, schedules ACL TX/RX transactions, monitors Bluetooth slot usage, optimally segments and packages data into baseband packets, manages connection status indicators, and composes and decodes HCI packets. In addition to these functions, it independently handles HCI event types and HCI command types.

The following transmit and receive functions are also implemented in the BBC hardware to increase TX/RX data reliability and security before sending over the air:

- Receive Functions: symbol timing recovery, data deframing, forward error correction (FEC), header error control (HEC), cyclic redundancy check (CRC), data decryption, and data dewatering.
- Transmit Functions: data framing, FEC generation, HEC generation, CRC generation, link key generation, data encryption, and data whitening.

Frequency Hopping Generator

The frequency hopping sequence generator selects the correct hopping channel number depending on the link controller state, Bluetooth clock, and device address.

E0 Encryption

The encryption key and the encryption engine are implemented using dedicated hardware to reduce software complexity and provide minimal processor intervention.

Link Control Layer

The link control layer is part of the Bluetooth link control functions that are implemented in dedicated logic in the Link Control Unit (LCU). This layer consists of the Command Controller, which takes software commands, and other controllers that are activated or configured by the Command Controller to perform the link control tasks. Each task performs a different Bluetooth link controller state. STANDBY and CONNECTION are the two major states. In addition, there are five substates: page, page scan, inquiry, and inquiry scan.

Adaptive Frequency Hopping

The BCM20737 gathers link quality statistics on a channel-by-channel basis to facilitate channel assessment and channel map selection. The link quality is determined by using both RF and baseband signal processing to provide a more accurate frequency hop map.

Bluetooth Low Energy Profiles

The BCM20737 supports Bluetooth low energy, including the following profiles that are supported¹ in ROM:

- Battery status
- Blood pressure monitor
- Find me
- Heart rate monitor
- Proximity
- Thermometer
- Weight scale
- Time
- Alliance for Wireless Power (A4WP) wireless charging
- Automation profile
- Support for secure OTA

The following additional profiles can be supported¹ from RAM:

- Blood glucose monitor
- Temperature alarm
- Location
- Custom profile

Test Mode Support

The BCM20737 fully supports Bluetooth Test mode, as described in the Bluetooth low energy specification.

1. Full qualification and use of these profiles may require FW updates from Broadcom. Some of these profiles are under development/approval at the Bluetooth SIG and conformity with the final approved version is pending. Contact your supplier for updates and the latest list of profiles.

Infrared Modulator

The BCM20737 includes hardware support for infrared TX. The hardware can transmit both modulated and unmodulated waveforms. For modulated waveforms, hardware inserts the desired carrier frequency into all IR transmissions. IR TX can be sourced from firmware-supplied descriptors, a programmable bit, or the peripheral UART transmitter.

If descriptors are used, they include IR on/off state and the duration between 1–32767 μ sec. The BCM20737 IR TX firmware driver inserts this information in a hardware FIFO and makes sure that all descriptors are played out without a glitch due to underrun (see [Figure 2](#)).

Figure 2: Infrared TX

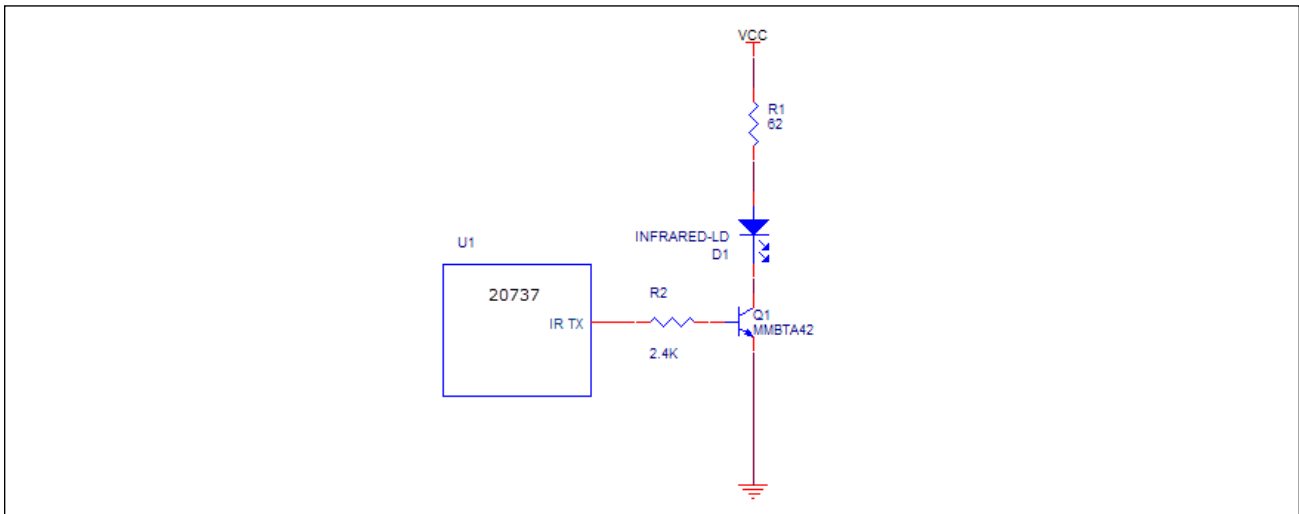

Infrared Learning

The BCM20737 includes hardware support for infrared learning. The hardware can detect both modulated and unmodulated signals. For modulated signals, the BCM20737 can detect carrier frequencies between 10 kHz–500 kHz and the duration that the signal is present or absent. The BCM20737 firmware driver supports further analysis and compression of learned signal. The learned signal can then be played back through the BCM20737 IR TX subsystem (see [Figure 3](#)).

Figure 3: Infrared RX

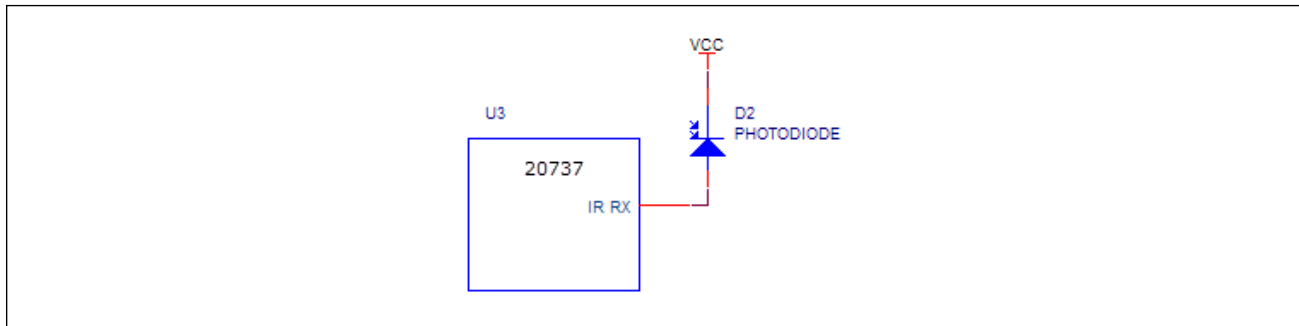

Wireless Charging

The BCM20737 includes support for wireless charging in hardware, software, and firmware. It supports the protocol for implementing wireless charging solutions based on the specifications written by the Alliance for Wireless Power (A4WP).

The A4WP protocol is embedded in the BCM20737. Hardware and firmware elements required for wireless charging are either implemented in the BCM20737 or can be obtained through a Broadcom technical support representative (see [page 8](#)).

An end-to-end charging solution comprises of the following:

- **Power Transmitting Unit (PTU):** The PTU transfers the power to the receiving unit. The receiving unit is any device (phone, wearable, or other embedded device) that needs to be charged. The PTU is typically plugged into a power source such as a wall outlet. The BCM20737 includes the peripherals needed to implement and drive a reference charging circuit and otherwise requires only a few external components. PTU reference designs based on the BCM20737, including bills of material (BOMs), are available through Broadcom technical support. Depending on charging power requirements, a Power Management Unit (PMU) such as the BCM8935X may be included in the design. However, most PTUs requiring < 5W will not need a PMU. The references designs leverage ADCs, PWMs, and other internal peripherals to help drive the charging circuitry for energy transfer as well as provide feedback for charging control. The application and algorithm that drive the reference designs are available on request.
- **Power Receive Unit (PRU):** The PRU receives energy from the PTU to charge the local device, and is typically embedded in the local device. Like the PTU, a separate PMU may or may not be needed depending on power requirements. PRU reference designs based on the BCM20736, both with and without a PMU, are also available through Broadcom technical support.

Security

BCM20737 provides elaborate mechanisms for implementing security and authentication schemes using:

- RSA (Public Key Cryptography)
- X.509 (excluding parsing)
- Hash functions: MD5, SHA-1, SHA-224, SHA-256, SHA-384, SHA-512
- Message authentication code: HMAC MD5, HMAC SHA-1



Note: Details on how to use this functionality via SDK are available in application notes on this topic.

Support for NFC Tag Based Pairing

BCM20737 provides support for "ease of pairing" and "secure key exchange" use cases using passive tags. Active tags can be used with the chip for OOB pairing. In a typical use case, the BCM20203 (NFC tag) can be used to provide "tap to pair" functionality for easy pairing.



Note: Details on how to use this functionality via SDK are available in application notes on this topic.

Bluetooth Smart Audio

BCM20737 supports using the BLE link for audio streaming. This functionality can be used for audio applications in toys, wearable, and HID devices, as well as in hearing aids.



Note: Details on how to use this functionality via SDK are available in application notes on this topic.

ADC Port

The BCM20737 contains a 16-bit ADC (effective number of bits is 10).

Additionally:

- There are 9 analog input channels in the 32-pin package
- The following GPIOs can be used as ADC inputs:
 - P0
 - P1
 - P8/P33 (select only one)
 - P11
 - P12
 - P13/P28 (select only one)
 - P14/P38 (select only one)
 - P15
 - P32
- The conversion time is 10 μ s.
- There is a built-in reference with supply- or bandgap-based reference modes.
- The maximum conversion rate is 187 kHz.
- There is a rail-to-rail input swing.

The ADC consists of an analog ADC core that performs the actual analog-to-digital conversion and digital hardware that processes the output of the ADC core into valid ADC output samples. Directed by the firmware, the digital hardware also controls the input multiplexers that select the ADC input signal V_{inp} and the ADC reference signals V_{ref} .

The ADC input range is selectable by firmware control:

- When an input range of 0–3.6V is used, the input impedance is 3 M Ω .
- When an input range of 0–2.4V is used, the input impedance is 1.84 M Ω .
- When an input range of 0–1.2V is used, the input impedance is 680 k Ω .

ADC modes are defined in [Table 1](#).

Table 1: ADC Modes

Mode	ENOB (Typical)	Maximum Sampling Rate (kHz)	Latency^a (μs)
0	13	5.859	171
1	12.6	11.7	85
2	12	46.875	21
3	11.5	93.75	11
4	10	187	5

a. Settling time after switching channels.

Serial Peripheral Interface

The BCM20737 has two independent SPI interfaces. One is a master-only interface and the other can be either a master or a slave. Each interface has a 16-byte transmit buffer and a 16-byte receive buffer. To support more flexibility for user applications, the BCM20737 has optional I/O ports that can be configured individually and separately for each functional pin as shown in [Table 2](#), [Table 3](#), and [Table 4](#). The BCM20737 acts as an SPI master device that supports 1.8V or 3.3V SPI slaves. The BCM20737 can also act as an SPI slave device that supports a 1.8V or 3.3V SPI master.

Table 2: BCM20737 First SPI Set (Master Mode)

Pin Name	SPI_CLK	SPI_MOSI	SPI_MISO^a	SPI_CS^b
Configured Pin Name	SCL	SDA	–	–
	–	–	–	–
	–	–	P32	P33 ^c

- SPIFFY1 MISO should always be P32. Boot ROM does not configure any others.
- Any GPIO can be used as SPI_CS when SPI 1 is in master mode, and when the SPI slave is not a serial flash.
- P33 is always SPI_CS when a serial flash is used for non-volatile storage.

Table 3: BCM20737 Second SPI Set (Master Mode)

Pin Name	SPI_CLK	SPI_MOSI	SPI_MISO	SPI_CS^a
Configured Pin Name	P3	P0	P1	–
	–	P4	P25	–
	P24	P27	–	–

- Any GPIO can be used as SPI_CS when SPI is in master mode.

Table 4: BCM20737 Second SPI Set (Slave Mode)

Pin Name	SPI_CLK	SPI_MOSI	SPI_MISO	SPI_CS
Configured Pin Name	P3	P0	P1	P2
	–	P27	–	–
	P24	P33	P25	P26
	–	–	–	P32

Microprocessor Unit

The BCM20737 microprocessor unit (μ PU) executes software from the link control (LC) layer up to the application layer components. The microprocessor is based on an ARM® Cortex™ M3, 32-bit RISC processor with embedded ICE-RT debug and JTAG interface units. The μ PU has 320 KB of ROM for program storage and boot-up, 60 KB of RAM for scratch-pad data, and patch RAM code. The SoC has a total storage of 380 KB, including RAM and ROM.

The internal boot ROM provides power-on reset flexibility, which enables the same device to be used in different HID applications with an external serial EEPROM or with an external serial flash memory. At power-up, the lowest layer of the protocol stack is executed from the internal ROM memory.

External patches may be applied to the ROM-based firmware to provide flexibility for bug fixes and feature additions. The device can also support the integration of user applications.

EEPROM Interface

The BCM20737 provides a Broadcom Serial Control (BSC) master interface. BSC is programmed by the CPU to generate four types of bus transfers: read-only, write-only, combined read/write, and combined write/read. BSC supports both low-speed and fast mode devices. BSC is compatible with an NXP® I²C slave device, except that master arbitration (multiple I²C masters contending for the bus) is not supported.

The EEPROM can contain customer application configuration information including application code, configuration data, patches, pairing information, BD_ADDR, baud rate, SDP service record, and file system information used for code.

Native support for the Microchip® 24LC128, Microchip 24AA128, and ST Micro® M24128-BR is included.

Serial Flash Interface

The BCM20737 includes an SPI master controller that can be used to access serial flash memory. The SPI master contains an AHB slave interface, transmit and receive FIFOs, and the SPI core PHY logic.

Devices natively supported include the following:

- Atmel® AT25BCM512B
- MXIC® MX25V512ZUI-20G

Other (larger) serial flash parts from MXIC, Numonyx, and Adesto with commands identical to these parts here are also supported.

Internal Reset

Figure 4: Internal Reset Timing

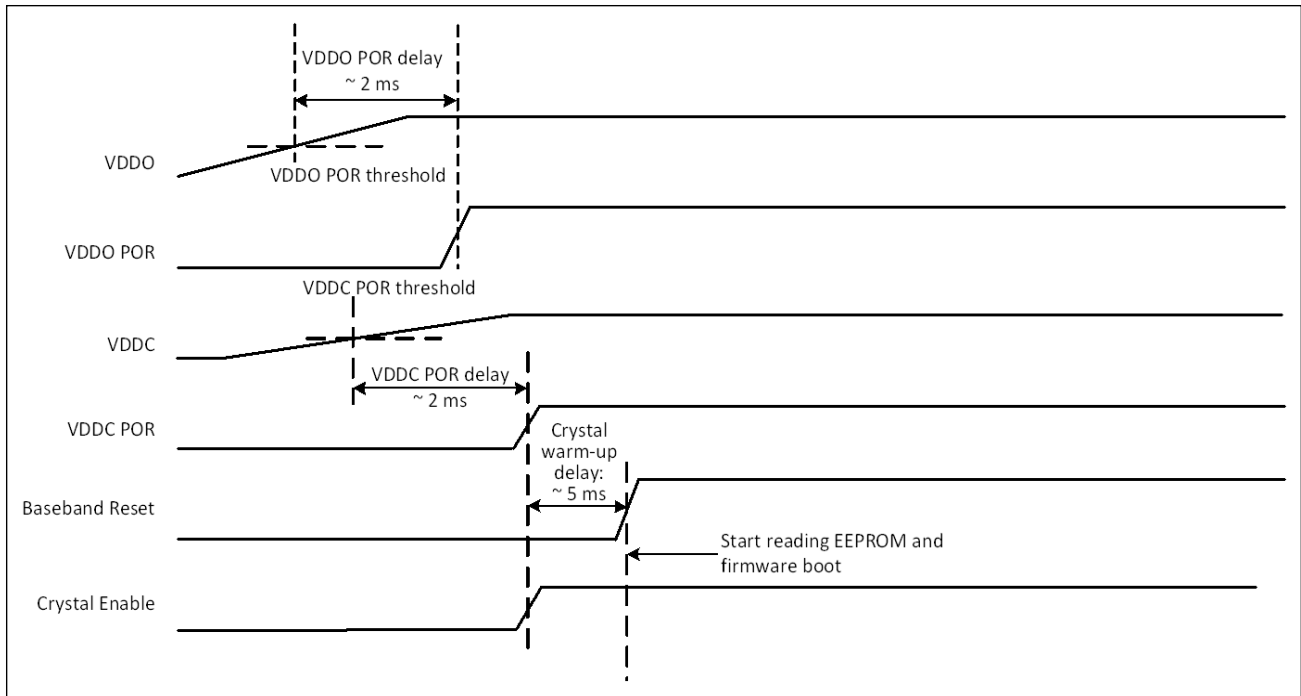

External Reset

The BCM20737 has an integrated power-on reset circuit that completely resets all circuits to a known power-on state. An external active low reset signal, RESET_N, can be used to put the BCM20737 in the reset state. The RESET_N pin has an internal pull-up resistor and, in most applications, it does not require that anything be connected to it. RESET_N should only be released after the VDDO supply voltage level has been stabilized.

Figure 5: External Reset Timing

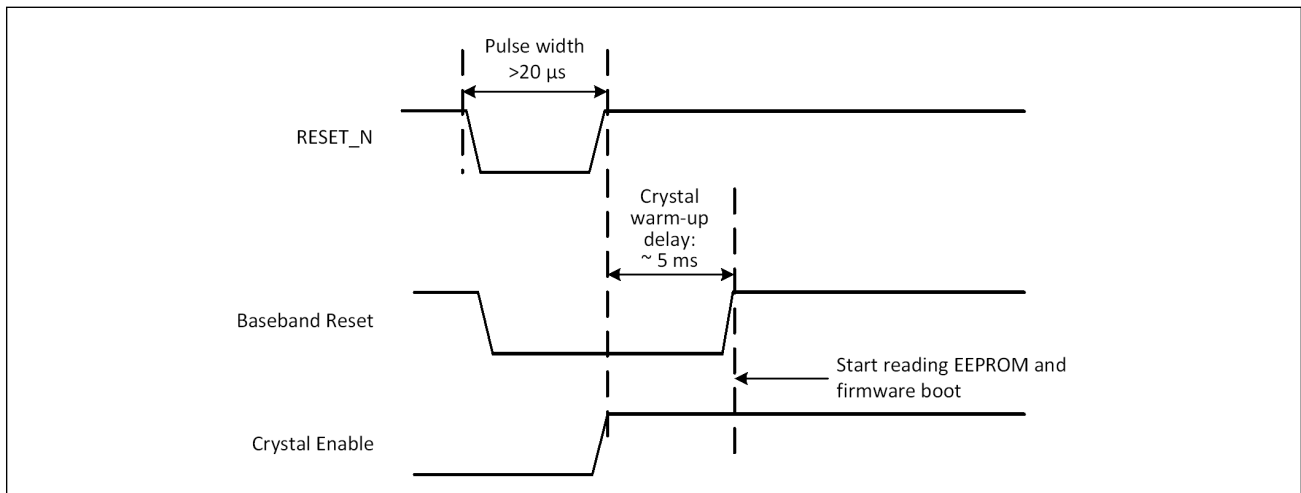

Integrated Radio Transceiver

The BCM20737 has an integrated radio transceiver that is optimized for 2.4 GHz Bluetooth wireless systems. It has been designed to provide low power, low cost, and robust communications for applications operating in the globally available 2.4 GHz unlicensed ISM band. It is fully compliant with Bluetooth Radio Specification 4.0 and meets or exceeds the requirements to provide the highest communication link quality of service.

Transmitter Path

The BCM20737 features a fully integrated transmitter. The baseband transmit data is GFSK modulated in the 2.4 GHz ISM band.

Digital Modulator

The digital modulator performs the data modulation and filtering required for the GFSK signal. The fully digital modulator minimizes any frequency drift or anomalies in the modulation characteristics of the transmitted signal.

Power Amplifier

The BCM20737 has an integrated power amplifier (PA) that can transmit up to +4 dBm for class 2 operation.

Receiver Path

The receiver path uses a low IF scheme to downconvert the received signal for demodulation in the digital demodulator and bit synchronizer. The receiver path provides a high degree of linearity, an extended dynamic range, and high-order, on-chip channel filtering to ensure reliable operation in the noisy 2.4 GHz ISM band. The front-end topology, which has built-in out-of-band attenuation, enables the BCM20737 to be used in most applications without off-chip filtering.

Digital Demodulator and Bit Synchronizer

The digital demodulator and bit synchronizer take the low-IF received signal and perform an optimal frequency tracking and bit synchronization algorithm.

Receiver Signal Strength Indicator

The radio portion of the BCM20737 provides a receiver signal strength indicator (RSSI) to the baseband. This enables the controller to take part in a Bluetooth power-controlled link by providing a metric of its own receiver signal strength to determine whether the transmitter should increase or decrease its output power.

Local Oscillator

The local oscillator (LO) provides fast frequency hopping (1600 hops/second) across the 79 maximum available channels. The BCM20737 uses an internal loop filter.

Calibration

The BCM20737 radio transceiver features a self-contained automated calibration scheme. No user interaction is required during normal operation or during manufacturing to provide optimal performance. Calibration compensates for filter, matching network, and amplifier gain and phase characteristics to yield radio performance within 2% of what is optimal. Calibration takes process and temperature variations into account, and it takes place transparently during normal operation and hop setting times.

Internal LDO Regulator

The BCM20737 has an integrated 1.2V LDO regulator that provides power to the digital and RF circuits. The 1.2V LDO regulator operates from a 1.425V to 3.63V input supply with a 30 mA maximum load current.



Note: Always place the decoupling capacitors near the pins as closely together as possible.

Peripheral Transport Unit

Broadcom Serial Communications Interface

The BCM20737 provides a 2-pin master BSC interface, which can be used to retrieve configuration information from an external EEPROM or to communicate with peripherals such as track-ball or touch-pad modules, and motion tracking ICs used in mouse devices. The BSC interface is compatible with I²C slave devices. The BSC does not support multimaster capability or flexible wait-state insertion by either master or slave devices.

The following transfer clock rates are supported by the BSC:

- 100 kHz
- 400 kHz
- 800 kHz (not a standard I²C-compatible speed.)
- 1 MHz (Compatibility with high-speed I²C-compatible devices is not guaranteed.)

The following transfer types are supported by the BSC:

- Read (Up to 16 bytes can be read.)
- Write (Up to 16 bytes can be written.)
- Read-then-Write (Up to 16 bytes can be read and up to 16 bytes can be written.)
- Write-then-Read (Up to 16 bytes can be written and up to 16 bytes can be read.)

Hardware controls the transfers, requiring minimal firmware setup and supervision.

The clock pin (SCL) and data pin (SDA) are both open-drain I/O pins. Pull-up resistors external to the BCM20737 are required on both the SCL and SDA pins for proper operation.

UART Interface

The UART is a standard 2-wire interface (RX and TX) and has adjustable baud rates from 9600 bps to 1.5 kbps. The baud rate can be selected via a vendor-specific UART HCI command. The interface supports the Bluetooth 3.0 UART HCI (H4) specification. The default baud rate for H4 is 115.2 kbaud.

Both high and low baud rates can be supported by running the UART clock at 24 MHz.

The BCM20737 UART operates correctly with the host UART as long as the combined baud rate error of the two devices is within $\pm 5\%$.

Clock Frequencies

The BCM20737 is set with crystal frequency of 24 MHz.

Crystal Oscillator

The crystal oscillator requires a crystal with an accuracy of ± 20 ppm as defined by the Bluetooth specification. Two external load capacitors in the range of 5 pF to 30 pF (see [Figure 6](#)) are required to work with the crystal oscillator. The selection of the load capacitors is crystal-dependent. [Table 5](#) shows the recommended crystal specifications.

Figure 6: Recommended Oscillator Configuration—12 pF Load Crystal

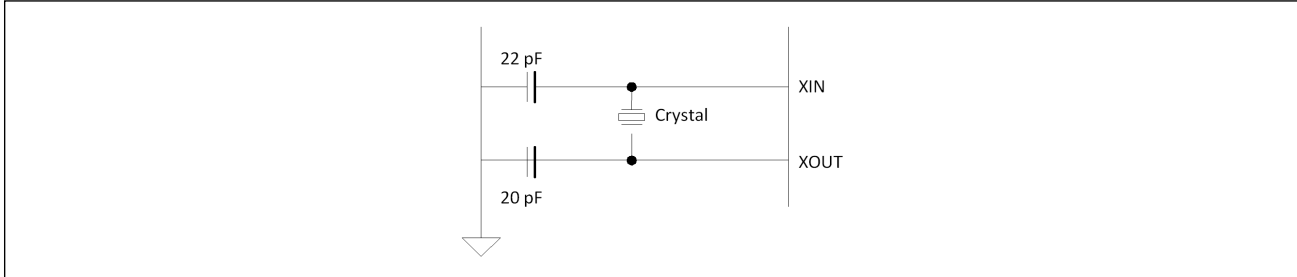

Table 5 shows the recommended crystal specifications.

Table 5: Reference Crystal Electrical Specifications

Parameter	Conditions	Minimum	Typical	Maximum	Unit
Nominal frequency	–	–	24.000	–	MHz
Oscillation mode	–	Fundamental			–
Frequency tolerance	@25°C	–	±10	–	ppm
Tolerance stability over temp	@0°C to +70°C	–	±10	–	ppm
Equivalent series resistance	–	–	–	50	Ω
Load capacitance	–	–	12	–	pF
Operating temperature range	–	0	–	+70	°C
Storage temperature range	–	–40	–	+125	°C
Drive level	–	–	–	200	μW
Aging	–	–	–	±10	ppm/year
Shunt capacitance	–	–	–	2	pF

Peripheral Block

The peripheral blocks of the BCM20737 all run from a single 128 kHz low-power RC oscillator. The oscillator can be turned on at the request of any of the peripherals. If the peripheral is not enabled, it shall not assert its clock request line.

The keyboard scanner is a special case, in that it may drop its clock request line even when enabled, and then reassert the clock request line if a keypress is detected.

32 kHz Crystal Oscillator

Figure 7 shows the 32 kHz crystal (XTAL) oscillator with external components and Table 6 lists the oscillator’s characteristics. It is a standard Pierce oscillator using a comparator with hysteresis on the output to create a single-ended digital output. The hysteresis was added to eliminate any chatter when the input is around the threshold of the comparator and is ~100 mV. This circuit can be operated with a 32 kHz or 32.768 kHz crystal oscillator or be driven with a clock input at similar frequency. The default component values are: R1 = 10 MΩ, C1 = C2 = ~10 pF. The values of C1 and C2 are used to fine-tune the oscillator.

Figure 7: 32 kHz Oscillator Block Diagram

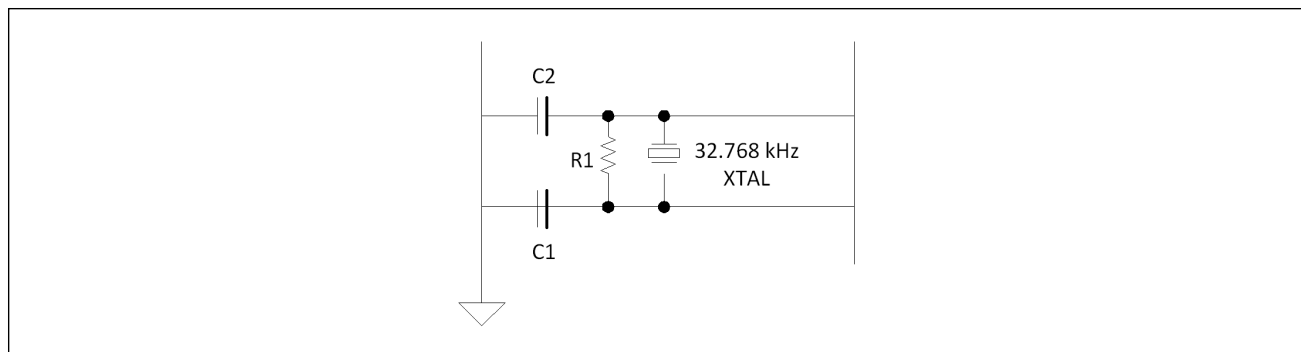

Table 6: XTAL Oscillator Characteristics

Parameter	Symbol	Conditions	Minimum	Typical	Maximum	Unit
Output frequency	F_{oscout}	–	–	32.768	–	kHz
Frequency tolerance	–	Crystal dependent	–	100	–	ppm
Start-up time	T_{startup}	–	–	–	500	ms
XTAL drive level	P_{drv}	For crystal selection	0.5	–	–	μW
XTAL series resistance	R_{series}	For crystal selection	–	–	70	$\text{k}\Omega$
XTAL shunt capacitance	C_{shunt}	For crystal selection	–	–	1.3	pF

GPIO Port

The BCM20737 has 14 general-purpose I/Os (GPIOs) in the 32-pin package. All GPIOs support programmable pull-up and pull-down resistors, and all support a 2 mA drive strength except P26, P27, and P28, which provide a 16 mA drive strength at 3.3V supply.

The following GPIOs are available:

- P0–P4
- P8/P33 (Dual bonded, only one of two is available.)
- P11/P27 (Dual bonded, only one of two is available.)
- P12/P26 (Dual bonded, only one of two is available.)
- P13/P28 (Dual bonded, only one of two is available.)
- P14/P38 (Dual bonded, only one of two is available.)
- P15
- P24
- P25
- P32

For a description of all GPIOs, see [Table 8: “GPIO Pin Descriptions,”](#) on page 27.

PWM

The BCM20737 has four internal PWM channels. The PWM module is described as follows:

- PWM0–3
- The following GPIOs can be mapped as PWMs:
 - P26
 - P27
 - P14/P28 (Dual bonded, only one of two is available.)
 - P13
- Each of the PWM channels, PWM0–3, contains the following registers:
 - 10-bit initial value register (read/write)
 - 10-bit toggle register (read/write)
 - 10-bit PWM counter value register (read)
- The PWM configuration register is shared among PWM0–3 (read/write). This 12-bit register is used:
 - To configure each PWM channel.
 - To select the clock of each PWM channel.
 - To change the phase of each PWM channel.

Figure 8 shows the structure of one PWM channel.

Figure 8: PWM Channel Block Diagram

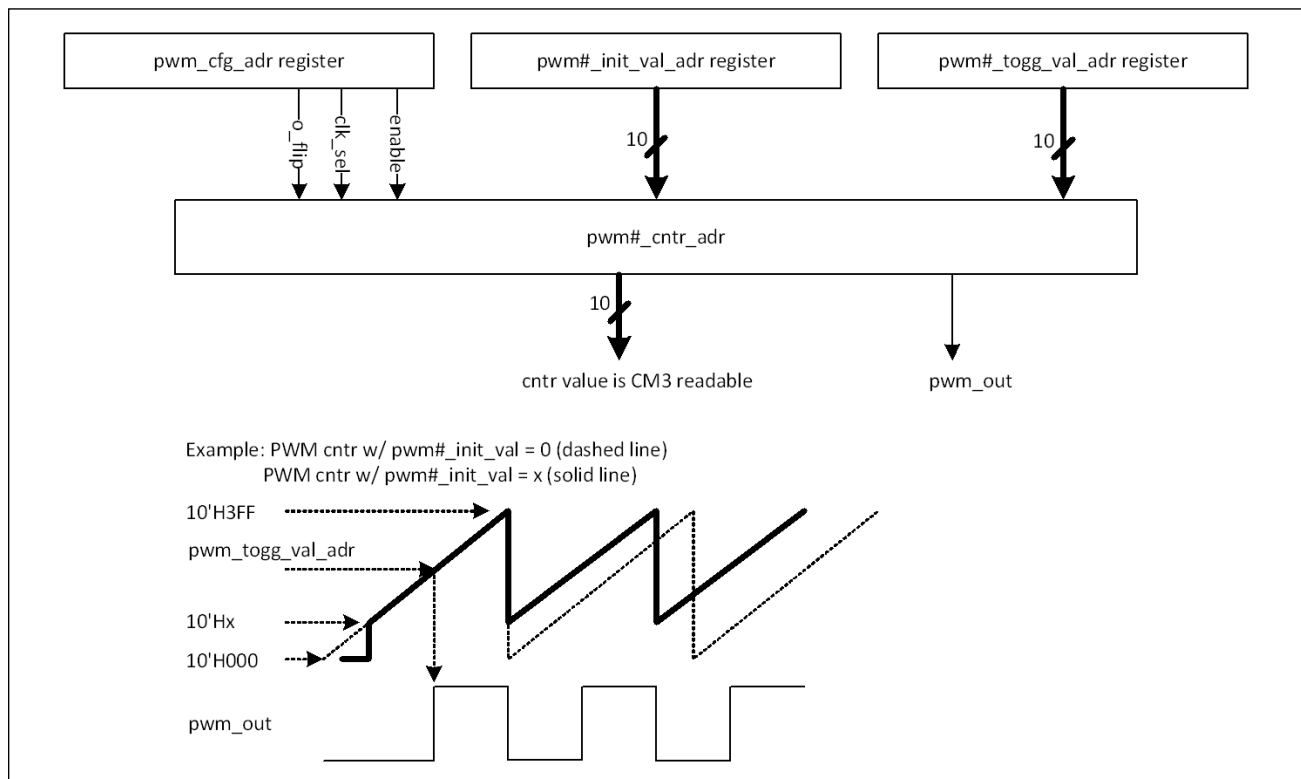

Power Management Unit

The Power Management Unit (PMU) provides power management features that can be invoked by software through power management registers or packet-handling in the baseband core.

RF Power Management

The BBC generates power-down control signals for the transmit path, receive path, PLL, and power amplifier to the 2.4 GHz transceiver, which then processes the power-down functions accordingly.

Host Controller Power Management

Power is automatically managed by the firmware based on input device activity. As a power-saving task, the firmware controls the disabling of the on-chip regulator when in deep sleep mode.

BBC Power Management

There are several low-power operations for the BBC:

- Physical layer packet handling turns RF on and off dynamically within packet TX and RX.
- Bluetooth-specified low-power connection mode. While in these low-power connection modes, the BCM20737 runs on the Low Power Oscillator and wakes up after a predefined time period.

The BCM20737 automatically adjusts its power dissipation based on user activity. The following power modes are supported:

- Active mode
- Idle mode
- Sleep mode
- HIDEOFF (Deep Sleep) mode
- Timed Deep Sleep mode

The BCM20737 transitions to the next lower state after a programmable period of user inactivity. Busy mode is immediately entered when user activity resumes.

In HIDEOFF (Deep Sleep) mode, the BCM20737 baseband and core are powered off by disabling power to LDOOUT. The VDDO domain remains powered up and will turn the remainder of the chip on when it detects user events. This mode minimizes chip power consumption and is intended for long periods of inactivity.

Section 2: Pin Assignments

Pin Descriptions

Table 7: Pin Descriptions

<i>Pin Number</i>	<i>Pin Name</i>	<i>I/O</i>	<i>Power Domain</i>	<i>Description</i>
Radio I/O				
6	RF	I/O	VDD_RF	RF antenna port
RF Power Supplies				
4	VDDIF	I	VDD_RF	IFPLL power supply
5	VDDFE	I	VDD_RF	RF front-end supply
7	VDDVCO	I	VDD_RF	VCO, LOGEN supply
8	VDDPLL	I	VDD_RF	RFPLL and crystal oscillator supply
Power Supplies				
11	VDDC	I	VDDC	Baseband core supply
28	VDDO	I	VDDO	I/O pad and core supply
14	VDDM	I	VDDM	I/O pad supply
Clock Generator and Crystal Interface				
9	XTALI	I	VDD_RF	Crystal oscillator input. See page 20 for options.
10	XTALO	O	VDD_RF	Crystal oscillator output.
1	XTALI32K	I	VDDO	Low-power oscillator (LPO) input is used. Alternative Function: <ul style="list-style-type: none"> • P11 • P27
32	XTALO32K	O	VDDO	Low-power oscillator (LPO) output. Alternative Function: <ul style="list-style-type: none"> • P12 • P26
Core				
18	RESET_N	I/O PU	VDDO	Active-low system reset with open-drain output & internal pull-up resistor
17	TMC	I	VDDO	Test mode control High: test mode Connect to GND if not used.
UART				
12	UART_RXD	I	VDDM	UART serial input – Serial data input for the HCI UART interface. Leave unconnected if not used. Alternative function: <ul style="list-style-type: none"> • GPIO3

Table 7: Pin Descriptions (Cont.)

Pin Number	Pin Name	I/O	Power Domain	Description
13	UART_TXD	O, PU	VDDM	UART serial output – Serial data output for the HCI UART interface. Leave unconnected if not used. Alternative Function: <ul style="list-style-type: none"> GPIO2
BSC				
15	SDA	I/O, PU	VDDM	Data signal for an external I ² C device. Alternative function: <ul style="list-style-type: none"> SPI_1: MOSI (master only) GPIO0 CTS
16	SCL	I/O, PU	VDDM	Clock signal for an external I ² C device. Alternative function: <ul style="list-style-type: none"> SPI_1: SPI_CLK (master only) GPIO1 RTS
LDO Regulator Power Supplies				
2	LDOIN	I	N/A	Battery input supply for the LDO
3	LDOOUT	O	N/A	LDO output

Table 8: GPIO Pin Descriptions^a

Pin Number	Pin Name	Default Direction	After POR State	Power Domain	Alternate Functions
19	P0	Input	Input floating	VDDO	<ul style="list-style-type: none"> GPIO: P0 PUART_TX (peripheral UART) SPI_2: MOSI (master and slave) ADC_IN29 (A/D converter input) IR_RX/60 Hz_main Not available during TMC=1
20	P1	Input	Input floating	VDDO	<ul style="list-style-type: none"> GPIO: P1 IR_TX PUART_RTS (peripheral UART) SPI_2: MISO (master and slave) ADC_IN28 (A/D converter input)
21	P3	Input	Input floating	VDDO	<ul style="list-style-type: none"> GPIO: P3 SPI_2: SPI_CLK (master and slave) Quadrature X1 PUART_CTS (peripheral UART)
22	P2	Input	Input floating	VDDO	<ul style="list-style-type: none"> GPIO: P2 SPI_2: SPI_MOSI (master only) Quadrature X0 PUART_RX (peripheral UART) SPI_2: SPI_CS (slave)
23	P4	Input	Input floating	VDDO	<ul style="list-style-type: none"> GPIO: P4 IR_TX SPI_2: MOSI (master and slave) Quadrature Y0 PUART_RX (peripheral UART)
24	P8	Input	Input floating	VDDO	<ul style="list-style-type: none"> GPIO: P8 ~TX_PD (external T/R switch control) ADC_IN27 (A/D converter input)
	P33	Input	Input floating	VDDO	<ul style="list-style-type: none"> GPIO: P33 ACLK1 (auxiliary clock output) SPI_2: MOSI (slave) ADC_IN6 (A/D converter input) QDX1 (quadrature X1) PUART_RX (peripheral UART)
	P9				<ul style="list-style-type: none"> GPIO: P9 TX_PD ADC_IN26

Table 8: GPIO Pin Descriptions^a (Cont.)

Pin Number	Pin Name	Default Direction	After POR State	Power Domain	Alternate Functions
	P10				<ul style="list-style-type: none"> • GPIO: P10 • PA_RAMP (power amplifier ramp) • ADC_IN25 (A/D converter input)
1	P11	Input	Input floating	VDDO	<ul style="list-style-type: none"> • GPIO: P11 • ADC_IN24 (A/D converter input) • XTALI32K
	P27	Input	Input floating	VDDO	<ul style="list-style-type: none"> • GPIO: P27 • QOC1 (quadrature output control) • SPI_2: MOSI (master and slave) • PWM1 Current: 16 mA
32	P12	Input	Input floating	VDDO	<ul style="list-style-type: none"> • GPIO: P12 • ADC_IN23 (A/D converter input) • XTALO32K
	P26	Input	Input floating	VDDO	<ul style="list-style-type: none"> • GPIO: P26 • QOC0 (quadrature output control) • SPI_2: SPI_CS (slave) • SPI_1: MISO (master) • PWM0 Current: 16 mA
29	P13	Input	Input floating	VDDO	<ul style="list-style-type: none"> • GPIO: P13 • PWM3 • ADC_IN22 (A/D converter input)
	P28	Input	Input floating	VDDO	<ul style="list-style-type: none"> • GPIO: P28 • QOC2 (quadrature output control) • ADC_IN11 (A/D converter input) • PWM2 • LED1 • IR_TX Current: 16 mA
30	P14	Input	Input floating	VDDO	<ul style="list-style-type: none"> • GPIO: P14 • PWM2 • ADC_IN21 (A/D converter input)
	P38	Input	Input floating	VDDO	<ul style="list-style-type: none"> • GPIO: P38 • IR_TX • SPI_2: MOSI (master and slave) • ADC_IN1 (A/D converter input)

Table 8: GPIO Pin Descriptions^a (Cont.)

Pin Number	Pin Name	Default Direction	After POR State	Power Domain	Alternate Functions
31	P15	Input	Input floating	VDDO	<ul style="list-style-type: none"> • GPIO: P15 • SWDIO • IR_RX/60 Hz_main • ADC_IN20 (A/D converter input)
27	P24	Input	Input floating	VDDO	<ul style="list-style-type: none"> • GPIO: P24 • PUART_TX (peripheral UART) • SPI_2: SPI_CLK (master and slave) • SPI_1: MISO (master)
26	P25	Input	Input floating	VDDO	<ul style="list-style-type: none"> • GPIO: P25 • SPI_2: MISO (master and slave) • PUART_RX (peripheral UART)
25	P32	Input	Input floating	VDDO	<ul style="list-style-type: none"> • GPIO: P32 • ACLK0 (auxiliary clock output) • PUART_TX (peripheral UART) • SPI_2: SPI_CS (slave) • ADC_IN7 (A/D converter input) • SPI_1: MISO (master)

a. During power-on reset, all inputs are disabled.

GPIO Pin Multiplexing

Table 9 provides GPIO pin multiplexing information.

Table 9: GPIO Pin Multiplexing

GPIO Pin	Alternate Functions					
	1	2	3	4	5	6
	Input/Output	Outputs			Inputs	
P0	–	PUART_TX	SPI_2: MOSI (master)	–	ADC_IN29	IR_RX/ 60 Hz_mai
P1	IR_TX	PUART_RTS	SPI_2: MISO (slave)	–	ADC_IN28	–
P2	–	SPI_2: MOSI (master)	–	–	QDX0	PUART_RX
P3	–	–	SPI_2: SPI_CLK (master)	–	QDX1	PUART_C
P4	IR_TX	–	SPI_2: MOSI (master)	–	QDY0	PUART_RX
P8/ P33 ^a	– ACLK1	~TX_PD –	–	– SPI_2: MOSI (slave)	ADC_IN27 ADC_IN6	– QDX1
P9	–	TX_PD	–	–	ADC_IN26	–
P10/	–	PA_RAMP	–	–	ADC_IN25	–
P11/	–	–	–	–	ADC_IN24	–
P27/xtal32i ^b	–	QOC1	SPI_2: MOSI (master)	SPI_2: MOSI (slave)	–	–
P12/	–	–	–	–	ADC_IN23	–
P26 ^c	–	QOC0	–	SPI_2: SPI_CS (slave)	SPI_1: MISO (master)	–
P13/	–	PWM3	–	–	ADC_IN22	–
P28 ^d	–	QOC2	–	–	ADC_IN11	–

Table 9: GPIO Pin Multiplexing

GPIO Pin	Alternate Functions					
	1	2	3	4	5	6
	Input/Output	Outputs		Inputs		
P14/ P38	–	PWM2	–	–	ADC_IN21	–
P15	IR_TX	–	SPI_2: MOSI (master)	SPI_2: MOSI (slave)	ADC_IN1	–
P24	–	SWDIO	–	IR_RX/ 60 Hz_main	ADC_IN20	SWDIO
P25	–	PUART_TX	–	SPI_2: SPI_CLK (slave)	SPI_1: MISO	–
P32	–	SPI_2: MISO (slave)	–	PUART_RX	SPI_2: MISO (master)	–
P32	ACLK0	PUART_TX	–	SPI_2: SPI_CS (slave)	ADC_IN7	QDX0

- a. If dual-bonded, then use one of P8 or P33.
- b. If quad-bonded, then use only one of P10, P11, or P27. P27 can source/sink 16 mA.
- c. If dual-bonded, then use one of P12 or P26. P27 can source/sink 16 mA.
- d. If dual-bonded, use one of P13 or P28. P28 can source/sink 16 mA.

Ball Maps

Figure 9: 32-pin QFN Ball Map

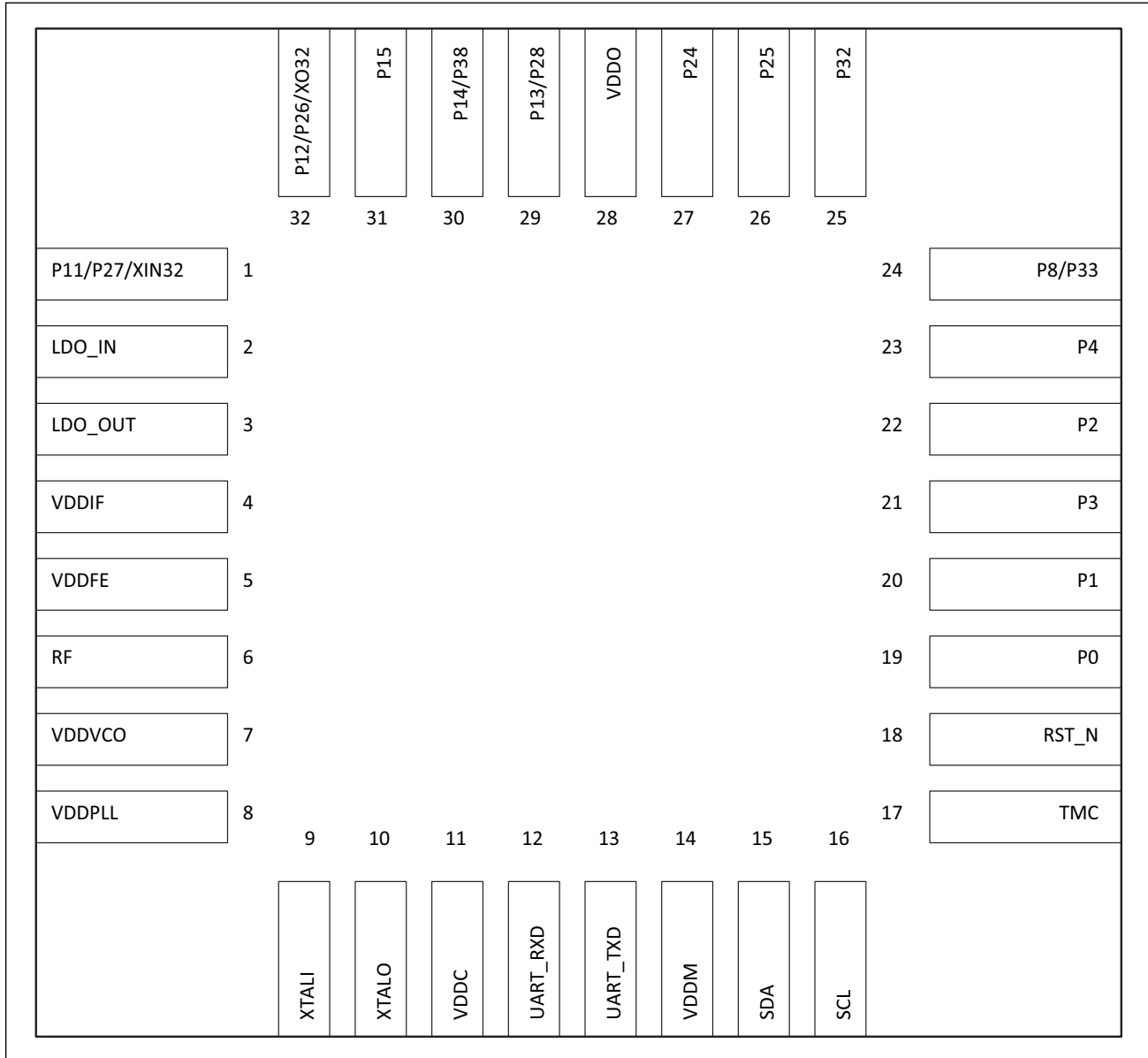

Section 3: Specifications

Electrical Characteristics

Table 10 shows the maximum electrical rating for voltages referenced to VDD pin.

Table 10: Maximum Electrical Rating

Rating	Symbol	Value	Unit
DC supply voltage for RF domain	–	1.4	V
DC supply voltage for core domain	–	1.4	V
DC supply voltage for VDDM domain (UART/I ² C)	–	3.8	V
DC supply voltage for VDDO domain	–	3.8	V
DC supply voltage for VR3V	–	3.8	V
DC supply voltage for VDDFE	–	1.4	V
Voltage on input or output pin	–	$V_{SS} - 0.3$ to $V_{DD} + 0.3$	V
Operating ambient temperature range	Topr	–30 to +85	°C
Storage temperature range	Tstg	–40 to +125	°C

Table 11 shows the power supply characteristics for the range $T_J = 0$ to 125°C .

Table 11: Power Supply

Parameter	Minimum ^a	Typical	Maximum ^a	Unit
DC supply voltage for RF	1.14	1.2	1.26	V
DC supply voltage for Core	1.14	1.2	1.26	V
DC supply voltage for VDDM (UART/I ² C)	1.62	–	3.63	V
DC supply voltage for VDDO	1.62	–	3.63	V
DC supply voltage for LDOIN	1.425	–	3.63	V
DC supply voltage for VDDFE	1.14	1.2 ^b	1.26	V

- a. Overall performance degrades beyond minimum and maximum supply voltages.
- b. 1.2V for Class 2 output with internal VREG.

Table 12 shows the digital level characteristics for (VSS = 0V).

Table 12: LDO Regulator Electrical Specifications

Parameter	Conditions	Min	Typ	Max	Unit
Input voltage range	–	1.425	–	3.63	V
Default output voltage	–	–	1.2	–	V
Output voltage	Range	0.8	–	1.4	V
	Step size	–	40 or 80	–	mV
	Accuracy at any step	–5	–	+5	%
Load current	–	–	–	30	mA
Line regulation	V _{in} from 1.425 to 3.63V, I _{load} = 30 mA	–0.2	–	0.2	%V _O /V
Load regulation	I _{load} from 1 μ A to 30 mA, V _{in} = 3.3V, Bonding R = 0.3 Ω	–	0.1	0.2	%V _O /mA
Quiescent current	No load @V _{in} = 3.3V *Current limit enabled	–	6	–	μ A
Power-down current	V _{in} = 3.3V, worst@70°C	–	5	200	nA

Table 13 shows the specifications for the ADC characteristics.

Table 13: ADC Specifications

Parameter	Symbol	Conditions	Min	Typ	Max	Unit
Number of Input channels	–	–	–	9	–	–
Channel switching rate	f _{ch}	–	–	–	133.33	kch/s
Input signal range	V _{inp}	–	0	–	3.63	V
Reference settling time	–	Changing refsel	7.5	–	–	μ s
Input resistance	R _{inp}	Effective, single ended	–	500	–	k Ω
Input capacitance	C _{inp}	–	–	–	5	pF
Conversion rate	f _C	–	5.859	–	187	kHz
Conversion time	T _C	–	5.35	–	170.7	μ s
Resolution	R	–	–	16	–	bits
Effective number of bits	–	In specified performance range	–	See Table 1 on page 14	–	–
Absolute voltage measurement error	–	Using on-chip ADC firmware driver	–	± 2	–	%
Current	I	I _{avdd1p2} + I _{avdd3p3}	–	–	1	mA
Power	P	–	–	1.5	–	mW
Leakage current	I _{leakage}	T = 25°C	–	–	100	nA
Power-up time	T _{powerup}	–	–	–	200	μ s
Integral nonlinearity ³	INL	In guaranteed performance range	–1	–	1	LSB ^a

Table 13: ADC Specifications (Cont.)

Parameter	Symbol	Conditions	Min	Typ	Max	Unit
Differential nonlinearity ^a	DNL	In guaranteed performance range	-1	-	1	LSB ^a

a. LSBs are expressed at the 10-bit level.

Table 14 shows the specifications for the digital voltage levels.

Table 14: Digital Levels^a

Characteristics	Symbol	Min	Typ	Max	Unit
Input low voltage	V_{IL}	-	-	0.4	V
Input high voltage	V_{IH}	$0.75 \times V_{DDO}$	-	-	V
Input low voltage (VDDO = 1.62V)	V_{IL}	-	-	0.4	V
Input high voltage (VDDO = 1.62V)	V_{IH}	1.2	-	-	V
Output low voltage ^b	V_{OL}	-	-	0.4	V
Output high voltage ^b	V_{OH}	$V_{DDO} - 0.4$	-	-	V
Input capacitance (VDDMEM domain)	C_{IN}	-	0.12	-	pF

a. This table is also applicable to VDDMEM domain.

b. At the specified drive current for the pad.

Table 15 shows the specifications for current consumption.

Table 15: Current Consumption^a

Operational Mode	Conditions	Typ	Max	Unit
Receive	Receiver and baseband are both operating, 100% ON.	9.8	10.0	mA
Transmit	Transmitter and baseband are both operating, 100% ON.	9.1	9.3	mA
Sleep	Internal LPO is in use.	12.0	13.0	μ A
	-	0.65	-	

a. Currents measured between power terminals (Vdd) using 90% efficient DC-DC converter at 3V.

Table 16: Power Supply Current Consumption

Power Supply	Advertisement Rates	Typ	Max	Unit
VDDC	20 ms	1.96		mA
	100 ms			
	500 ms			
	1 s			

RF Specifications

Table 17: Receiver RF Specifications

Parameter	Mode and Conditions	Min	Typ	Max	Unit
Receiver Section^a					
Frequency range	–	2402	–	2480	MHz
RX sensitivity (standard)	0.1%BER, 1 Mbps	–	–94	–	dBm
RX sensitivity (low current)		–	–91.5	–	dBm
Input IP3	–	–16	–	–	dBm
Maximum input	–	–10	–	–	dBm
Interference Performance^{a,b}					
C/I cochannel	0.1%BER	–	–	21	dB
C/I 1 MHz adjacent channel	0.1%BER	–	–	15	dB
C/I 2 MHz adjacent channel	0.1%BER	–	–	–17	dB
C/I ≥ 3 MHz adjacent channel	0.1%BER	–	–	–27	dB
C/I image channel	0.1%BER	–	–	–9.0	dB
C/I 1 MHz adjacent to image channel	0.1%BER	–	–	–15	dB
Out-of-Band Blocking Performance (CW)^{a,b}					
30 MHz to 2000 MHz	0.1%BER ^c	–	–30.0	–	dBm
2003 MHz to 2399 MHz	0.1%BER ^d	–	–35	–	dBm
2484 MHz to 2997 MHz	0.1%BER ^d	–	–35	–	dBm
3000 MHz to 12.75 GHz	0.1%BER ^e	–	–30.0	–	dBm
Spurious Emissions					
30 MHz to 1 GHz	–	–	–	–57.0	dBm
1 GHz to 12.75 GHz	–	–	–	–55.0	dBm

a. 30.8% PER.

b. Desired signal is 3 dB above the reference sensitivity level (defined as –70 dBm).

c. Measurement resolution is 10 MHz.

d. Measurement resolution is 3 MHz.

e. Measurement resolution is 25 MHz.

Table 18: Transmitter RF Specifications

Parameter	Minimum	Typical	Maximum	Unit
Transmitter Section				
Frequency range	2402	–	2480	MHz
Output power adjustment range	–20	–	4	dBm
Default output power	–	4.0	–	dBm
Output power variation	–	2.0	–	dB
Adjacent Channel Power				

Table 18: Transmitter RF Specifications (Cont.)

Parameter	Minimum	Typical	Maximum	Unit
$ M - N = 2$	–	–	–20	dBm
$ M - N \geq 3$	–	–	–30	dBm
Out-of-Band Spurious Emission				
30 MHz to 1 GHz	–	–	–36.0	dBm
1 GHz to 12.75 GHz	–	–	–30.0	dBm
1.8 GHz to 1.9 GHz	–	–	–47.0	dBm
5.15 GHz to 5.3 GHz	–	–	–47.0	dBm
LO Performance				
Initial carrier frequency tolerance	–	–	±150	kHz
Frequency Drift				
Frequency drift	–	–	±50	kHz
Drift rate	–	–	20	kHz/50 μ s
Frequency Deviation				
Average deviation in payload (sequence used is 00001111)	225	–	275	kHz
Maximum deviation in payload (sequence used is 10101010)	185	–	–	kHz
Channel spacing	–	2	–	MHz

Timing and AC Characteristics

In this section, use the numbers listed in the **Reference** column of each table to interpret the following timing diagrams.

UART Timing

Table 19: UART Timing Specifications

Reference	Characteristics	Min	Max	Unit
1	Delay time, UART_CTS_N low to UART_TXD valid	–	24	Baud out cycles
2	Setup time, UART_CTS_N high before midpoint of stop bit	–	10	ns
3	Delay time, midpoint of stop bit to UART_RTS_N high	–	2	Baud out cycles

Figure 10: UART Timing

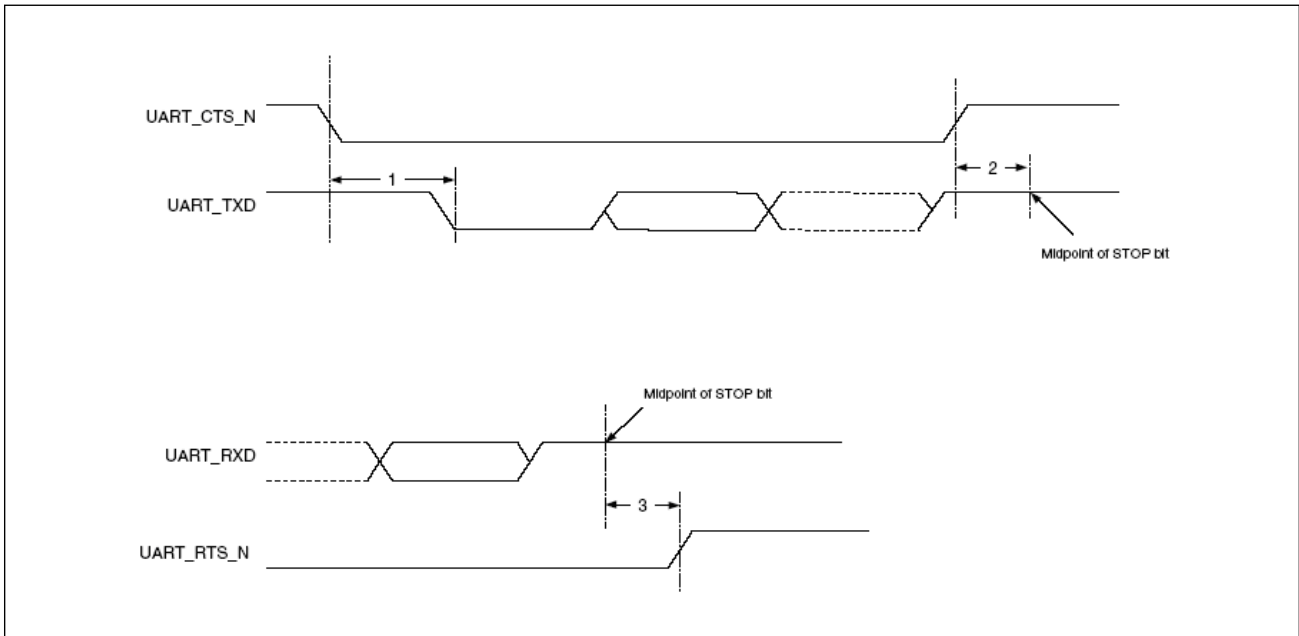

SPI Timing

The SPI interface supports clock speeds up to 12 MHz with $VDDIO \geq 2.2V$. The supported clock speed is 6 MHz when $2.2V > VDDIO \geq 1.62V$.

Figure 11 and Figure 12 show the timing requirements when operating in SPI Mode 0 and 2, and SPI Mode 1 and 3, respectively.

Table 20: SPI Interface Timing Specifications

Reference	Characteristics	Min	Typ	Max
1	Time from CSN asserted to first clock edge	1 SCK	100	∞
2	Master setup time	–	$\frac{1}{2}$ SCK	–
3	Master hold time	$\frac{1}{2}$ SCK	–	–
4	Slave setup time	–	$\frac{1}{2}$ SCK	–
5	Slave hold time	$\frac{1}{2}$ SCK	–	–
6	Time from last clock edge to CSN deasserted	1 SCK	10 SCK	100

Figure 11: SPI Timing – Mode 0 and 2

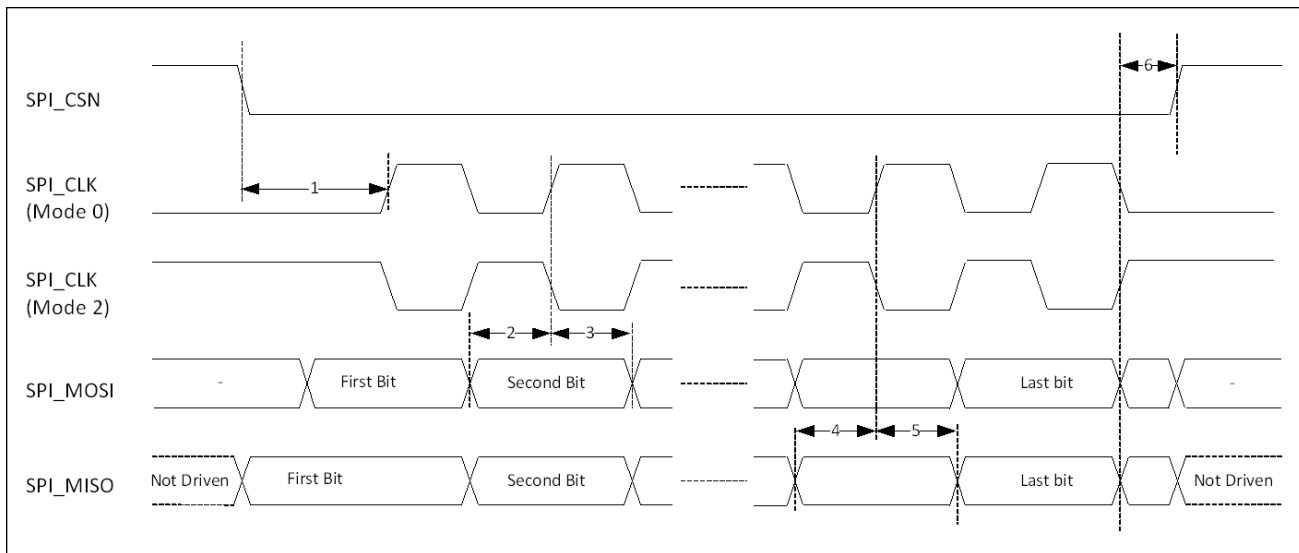
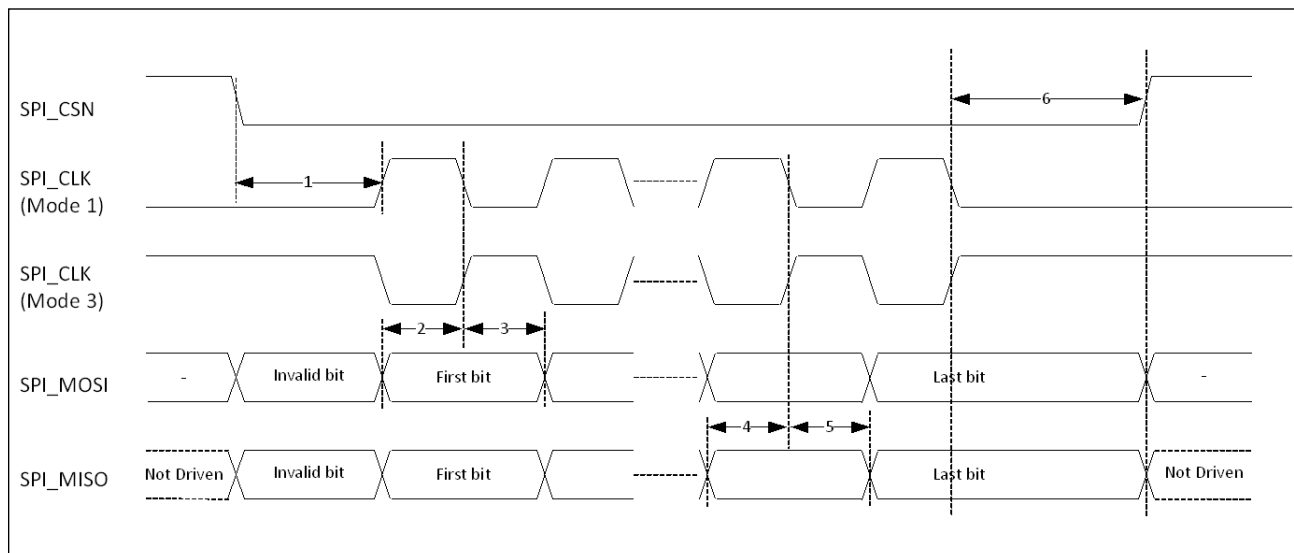

Figure 12: SPI Timing – Mode 1 and 3



BSC Interface Timing

Table 21: BSC Interface Timing Specifications

Reference	Characteristics	Min	Max	Unit
1	Clock frequency	–	100 400 800 1000	kHz
2	START condition setup time	650	–	ns
3	START condition hold time	280	–	ns
4	Clock low time	650	–	ns
5	Clock high time	280	–	ns
6	Data input hold time ^a	0	–	ns
7	Data input setup time	100	–	ns
8	STOP condition setup time	280	–	ns
9	Output valid from clock	–	400	ns
10	Bus free time ^b	650	–	ns

- a. As a transmitter, 300 ns of delay is provided to bridge the undefined region of the falling edge of SCL to avoid unintended generation of START or STOP conditions.
- b. Time that the cbus must be free before a new transaction can start.

Figure 13: BSC Interface Timing Diagram

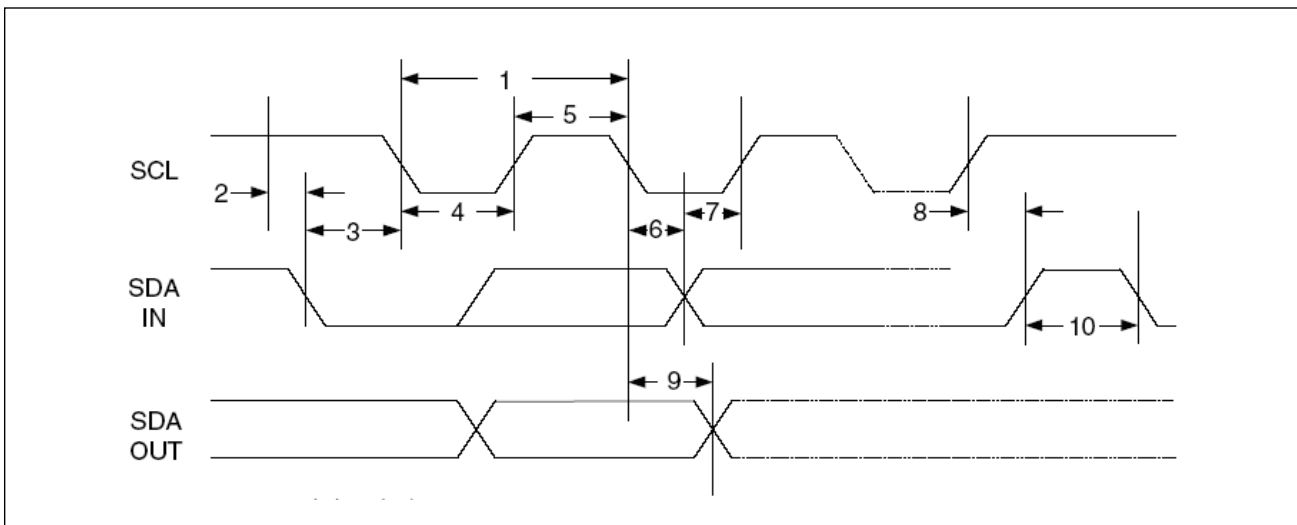

ESD Test Models

ESD can have serious detrimental effects on all semiconductor ICs and the system that contains them. Standards are developed to enhance the quality and reliability of ICs by ensuring all devices employed have undergone proper ESD design and testing, thereby minimizing the detrimental effects of ESD. Three major test methods are widely used in the industry today to describe uniform methods for assessing ESD immunity at Component level, Human Body Model (HBM), Machine Model (MM), and Charged Device Model (CDM). The following standards were used to test this device:

Human-Body Model (HBM) – ANSI/ESDA/JEDEC JS-001-2012

The HBM has been developed to simulate the action of a human body discharging an accumulated static charge through a device to ground, and employs a series RC network consisting of a 100 pF capacitor and a 1500 Ω (Ohm) resistor. Both positive and negative polarities are used for this test. Although, a 100 ms delay is allowable per specification, the minimum delay used for testing was set to 300 ms between each pulse.

Machine Model (MM) – JEDEC JESD22-A115C

The MM has been developed to simulate the rapid discharge from a charged conductive object, such as a metallic tool or fixture. The most common application would be rapid discharge from charged board assembly or the charged cables of automated testers. This model consists of a 200 pF capacitor discharged directly into a component with no series resistor (0 Ω). One positive and one negative polarity pulses are applied. The minimum delay between pulses is 500 ms.

Charged-Device Model (CDM) - JEDEC JESD22-C101E

CDM simulates charging/discharging events that occur in production equipment and processes. The potential for a CDM ESD events occurs when there is metal-to-metal contact in manufacturing. CDM addresses the possibility that a charge may reside on the lead frame or package (e.g., from shipping) and discharge through a pin that subsequently is grounded, causing damage to sensitive devices in the path. Discharge current is limited only by the parasitic impedance and capacitance of the device. CDM testing consists of charging package to a specified voltage, then discharging the voltage through relevant package leads. One positive and one negative polarity pulse is applied. The minimum delay between pulses is 200 ms.

Results Summary

ESD Test Voltage Level Results:

- HBM +/- 2KV PASS
- CDM +/- 500V PASS
- MM +/- 150V PASS

Section 4: Mechanical Information

Figure 14: 32-pin QFN

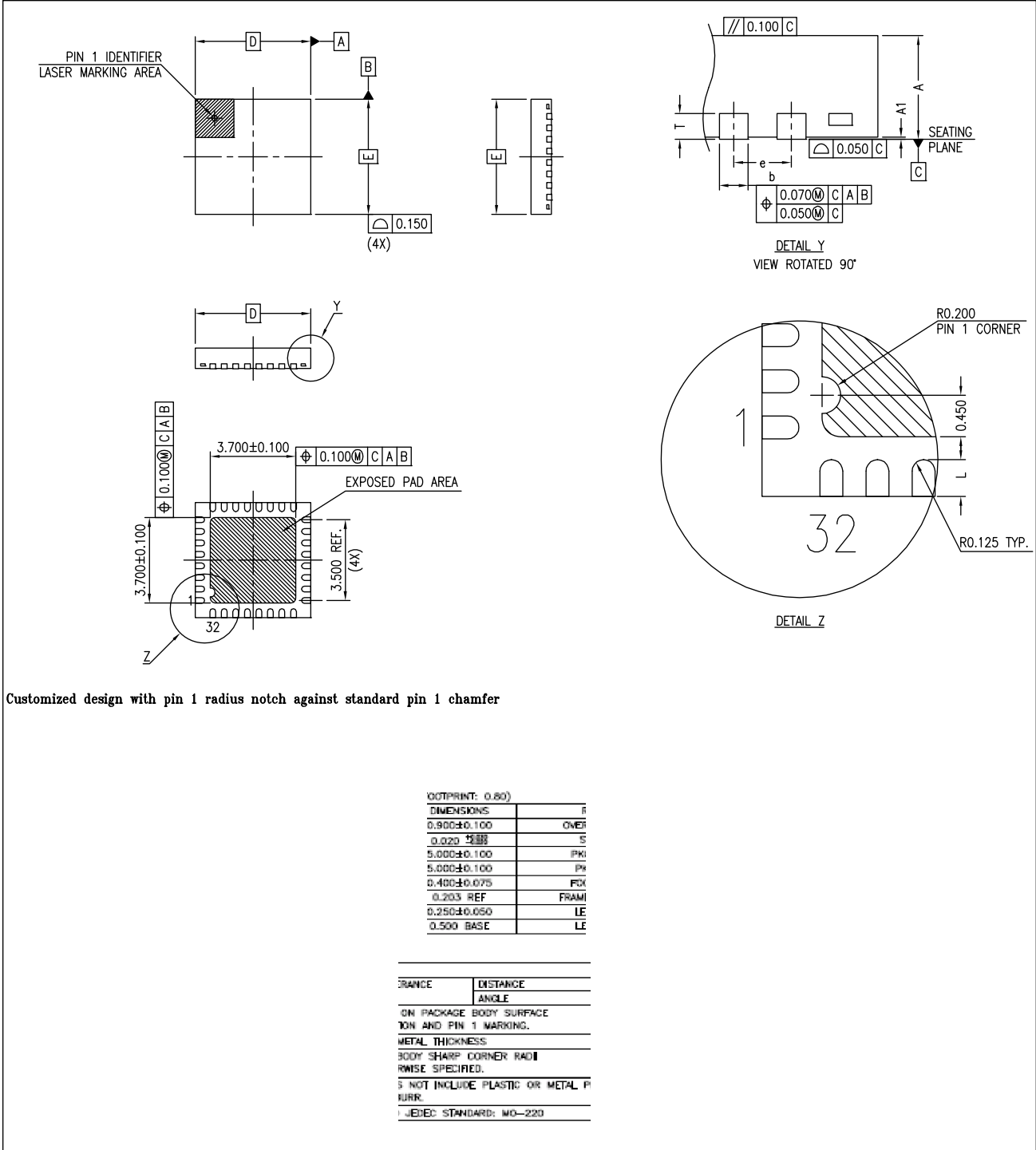

Tape Reel and Packaging Specifications

Table 22: BCM20737 5 × 5 × 1 mm QFN, 32-Pin Tape Reel Specifications

Parameter	Value
Quantity per reel	2500 pieces
Reel diameter	13 inches
Hub diameter	7 inches
Tape width	12 mm
Tape pitch	8 mm

The top left corner of the BCM20737 package is situated near the sprocket holes, as shown in [Figure 15](#).

Figure 15: Pin 1 Orientation

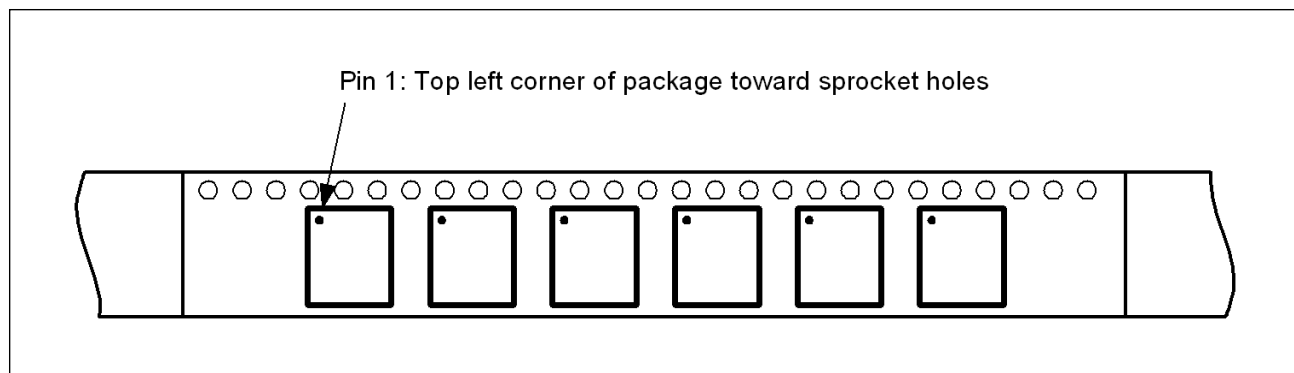

Section 5: Ordering Information

Table 23: Ordering Information

Part Number	Package	Ambient Operating Temperature
BCM20737A1KML2G	32-pin QFN	-30°C to +85°C

Appendix A: Acronyms and Abbreviations

The following list of acronyms and abbreviations may appear in this document.

Term	Description
ADC	analog-to-digital converter
AFH	adaptive frequency hopping
AHB	advanced high-performance bus
APB	advanced peripheral bus
APU	audio processing unit
ARM7TDMI-S®	Acorn RISC Machine 7 Thumb instruction, Debugger, Multiplier, Ice, Synthesizable
BSC	Broadcom Serial Control
BTC	Bluetooth controller
COEX	coexistence
DFU	device firmware update
DMA	direct memory access
EBI	external bus interface
HCI	Host Control Interface
HV	high voltage
IDC	initial digital calibration
IF	intermediate frequency
IRQ	interrupt request
JTAG	Joint Test Action Group
LCU	link control unit
LDO	low drop-out
LHL	lean high land
LPO	low power oscillator
LV	LogicVision™
MIA	multiple interface agent
PCM	pulse code modulation
PLL	phase locked loop
PMU	power management unit
POR	power-on reset
PWM	pulse width modulation
QD	quadrature decoder
RAM	random access memory
RF	radio frequency
ROM	read-only memory
RX/TX	receive, transmit
SPI	serial peripheral interface

<i>Term</i>	<i>Description</i>
SW	software
UART	universal asynchronous receiver/transmitter
UPI	μ -processor interface
WD	watchdog

Broadcom® Corporation reserves the right to make changes without further notice to any products or data herein to improve reliability, function, or design.

Information furnished by Broadcom Corporation is believed to be accurate and reliable. However, Broadcom Corporation does not assume any liability arising out of the application or use of this information, nor the application or use of any product or circuit described herein, neither does it convey any license under its patent rights nor the rights of others.

Broadcom Corporation

5300 California Avenue
Irvine, CA 92617

© 2016 by BROADCOM CORPORATION. All rights reserved.

20737-DS102-R

August 17, 2016



Phone: 949-926-5000

Fax: 949-926-5203

E-mail: info@broadcom.com

Web: www.broadcom.com

X-ON Electronics

Largest Supplier of Electrical and Electronic Components

Click to view similar products for [RF System on a Chip - SoC category](#):

Click to view products by [Cypress manufacturer](#):

Other Similar products are found below :

[BCM20737A1KML2G](#) [BCM43236BKMLG](#) [EM06ELA-512-SGAS](#) [CYBL10463-56LQXI](#) [CYBL10562-56LQXI](#) [CYBL10563-68FLXIT](#)
[ATBTLC1000A-UU-T](#) [EC25AUFA-MINIPCIE](#) [BCM43242KFFBG](#) [BCM20707UA1KFFB1G](#) [ATWILC1000B-UU-T](#) [BCM4322KFBGH](#)
[ETRX3DVK357](#) [EC25VFA-MINIPCIE](#) [EC25JFA-MINIPCIE](#) [EC25MXGA-MINIPCIE](#) [EC25AFXGA-MINIPCIE](#) [EC25AUXGA-MINIPCIE](#)
[EC25AUGC-MINIPCIE](#) [EC25AUTFA-MINIPCIE](#) [EC25AFFA-MINIPCIE](#) [EP06ALA-512-SGAD](#) [EM06ALA-512-SGAD](#) [EM12GPA-512-](#)
[SGAD](#) [EC25EUGA-MINIPCIE](#) [TLR8367EP16](#) [EC25AFA-MINIPCIE](#) [CYBL10463-56LQXIT](#) [CC2511F32RSPR](#) [AX-SFEU-API-1-01-](#)
[TB05](#) [NRF51422-CFAC-R](#) [NRF51822-CDAB-R](#) [XR1015-QH-0G00](#) [EM3585-RT](#) [NCH-RSL10-101Q48-ABG](#) [AX8052F143-3-TX30](#)
[BLUENRG-232](#) [ESP32-D2WD](#) [AWR1642ABIGABLQ1](#) [ESP32-D0WD](#) [ESP8266EX](#) [CYBL10561-56LQXI](#) [ATWINC1500B-MU-Y](#)
[DA14531-00000FX2](#) [ESP32-C3FH4](#) [ESP32-C3](#) [ESP32-D0WDQ6](#) [ESP32-D0WDQ6-V3](#) [ESP32-D0WD-V3](#) [ESP32-PICO-V3](#)