



The following document contains information on Cypress products. Although the document is marked with the name “Broadcom”, the company that originally developed the specification, Cypress will continue to offer these products to new and existing customers.

CONTINUITY OF SPECIFICATIONS

There is no change to this document as a result of offering the device as a Cypress product. Any changes that have been made are the result of normal document improvements and are noted in the document history page, where supported. Future revisions will occur when appropriate, and changes will be noted in a document history page.

CONTINUITY OF ORDERING PART NUMBERS

Cypress continues to support existing part numbers. To order these products, please use only the Ordering Part Numbers listed in this document.

FOR MORE INFORMATION

Please visit our website at www.cypress.com or contact your [local sales office](#) for additional information about Cypress products and services.

OUR CUSTOMERS

Cypress is for true innovators – in companies both large and small.

Our customers are smart, aggressive, out-of-the-box thinkers who design and develop game-changing products that revolutionize their industries or create new industries with products and solutions that nobody ever thought of before.

ABOUT CYPRESS

Founded in 1982, Cypress is the leader in advanced embedded system solutions for the world’s most innovative automotive, industrial, home automation and appliances, consumer electronics and medical products. Cypress’s programmable systems-on-chip, general-purpose microcontrollers, analog ICs, wireless and USB-based connectivity solutions and reliable, high-performance memories help engineers design differentiated products and get them to market first.

Cypress is committed to providing customers with the best support and engineering resources on the planet enabling innovators and out-of-the-box thinkers to disrupt markets and create new product categories in record time. To learn more, go to www.cypress.com.



Bluetooth Low Energy System-in-Package (SiP) Module

GENERAL DESCRIPTION

The BCM20737S is a compact, highly integrated Bluetooth low energy (BLE) system-in-package (SiP) module. The BCM20737S SiP includes an embedded BLE antenna, 24 MHz clock, and 512 Kb EEPROM, so only a minimal set of external components is needed to create a standalone BLE device.

The BCM20737S is designed to accelerate time to market. The Bluetooth stack and several application profiles are built into the module, allowing customers to focus on their core applications. To further reduce application development time, the BCM20737S includes integrated software support, with one-click installation of the complete environment and a one-click compile/build/link/load cycle. All this, coupled with an ultrasmall form factor and support for a wide voltage range, makes the BCM20737S well suited for virtually any Bluetooth Smart application.

FEATURES

- ARM Cortex-M3 microcontroller unit (MCU)
- Embedded 512 Kb EEPROM
- Broadcom Serial Control (BSC), SPI, and UART interfaces
- FCC and CE compliant
- RoHS compliant, certified lead- and halogen-free

FEATURES

- Moisture Sensitivity Level (MSL) 3 compliant
- 6.5 mm × 6.5 mm × 1.2 mm Land Grid Array (LGA) 48-pin package

APPLICATIONS

Profiles supported in ROM:

- Battery status
- Blood pressure monitor
- Find me
- Heart rate monitor
- Proximity
- Thermometer
- Weight scale
- Time
- Blood glucose monitor
- Support for RSA security library
- Support for LE Audio
- Support for pairing using NFC tags

Additional profiles supported in RAM:

- Blood glucose monitor
- Temperature alarm
- Location
- Other custom profiles

Figure 1: BCM20737S BLE SiP Block Diagram

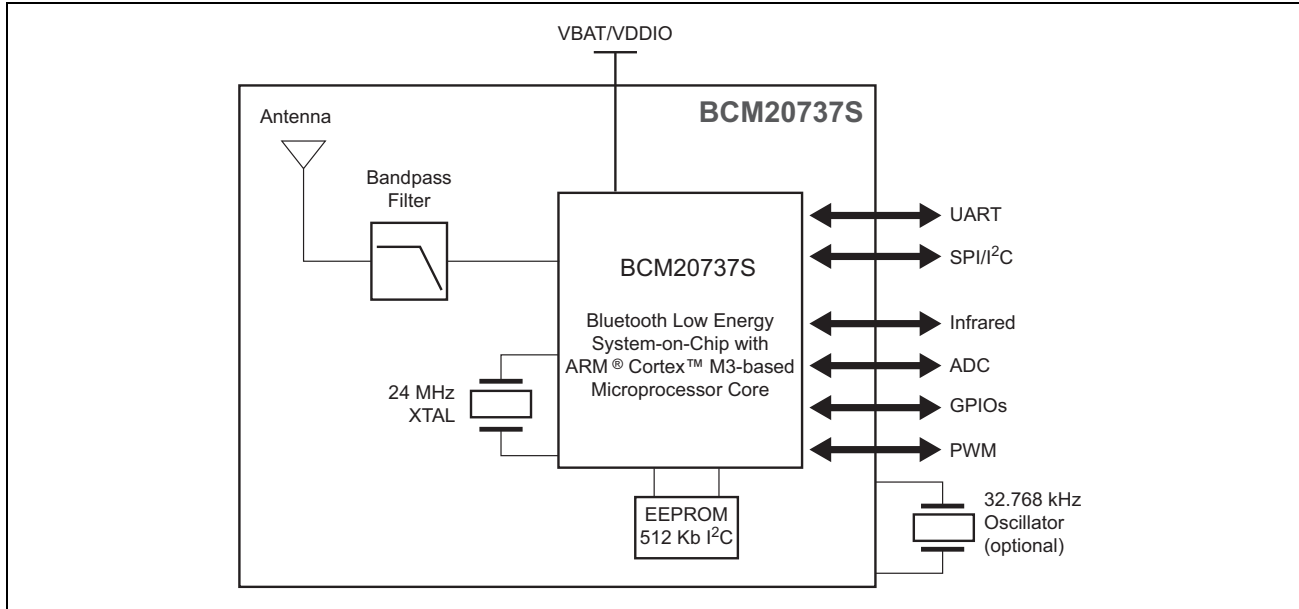

© 2016 by Broadcom. All rights reserved.

Broadcom[®], the pulse logo, Connecting everything[®], the Connecting everything logo, and Avago Technologies are among the trademarks of Broadcom and/or its affiliates in the United States, certain other countries and/or the EU. Any other trademarks or trade names mentioned are the property of their respective owners.

Broadcom reserves the right to make changes without further notice to any products or data herein to improve reliability, function, or design.

Information furnished by Broadcom is believed to be accurate and reliable. However, Broadcom does not assume any liability arising out of the application or use of this information, nor the application or use of any product or circuit described herein, neither does it convey any license under its patent rights nor the rights of others.

This data sheet (including, without limitation, the Broadcom component(s) identified herein) is not designed, intended, or certified for use in any military, nuclear, medical, mass transportation, aviation, navigations, pollution control, hazardous substances management, or other high-risk application. BROADCOM PROVIDES THIS DATA SHEET "AS-IS," WITHOUT WARRANTY OF ANY KIND. BROADCOM DISCLAIMS ALL WARRANTIES, EXPRESSED AND IMPLIED, INCLUDING, WITHOUT LIMITATION, THE IMPLIED WARRANTIES OF MERCHANTABILITY, FITNESS FOR A PARTICULAR PURPOSE, AND NON-INFRINGEMENT.

Revision History

<i>Revision</i>	<i>Date</i>	<i>Change Description</i>
20737S-DS101-R	04/10/16	Updated: <ul style="list-style-type: none">• Table 5: "Current Consumption," on page 14
20737S-DS100-R	09/26/2014	Initial release

Table of Contents

About This Document 7

 Purpose and Audience 7

 Acronyms and Abbreviations 7

 Document Conventions 7

Technical Support 7

Section 1: Functional Description 8

 External Reset 8

 32.768 kHz Oscillator 8

Section 2: Pin Map and Signal Descriptions 9

Section 3: Electrical Specifications 14

Section 4: RF Specifications 15

Section 5: ADC Specifications 16

Section 6: Timing and AC Characteristics 17

 SPI Timing 17

 BSC Interface Timing 18

 UART Timing 19

Section 7: PCB Design and Manufacturing Recommendations 20

 Pad and Solder Mask Opening Dimensions 20

 PCB Layout Recommendations 20

 PCB Stencil 22

 Solder Reflow 22

Section 8: Packaging and Storage Information 23

Section 9: Mechanical Information 25

Section 10: Ordering Information 27

List of Figures

Figure 1: BCM20737S BLE SiP Block Diagram.....	2
Figure 2: External Reset Timing	8
Figure 3: BCM20737S (TOP View).....	9
Figure 4: SPI Timing—Modes 0 and 2	17
Figure 5: SPI Timing—Modes 1 and 3	17
Figure 6: BSC Interface Timing.....	18
Figure 7: UART Timing	19
Figure 8: PCB Layout Example.....	21
Figure 9: BCM20737S Stencil (Bottom View).....	22
Figure 10: Solder Reflow Profile	22
Figure 11: BCM20737S ESD/Moisture Packaging	23
Figure 12: BCM20737S Moisture Sensitivity Label.....	24
Figure 13: BCM20737S Tape and Reel Pin 1 Location	24
Figure 14: BCM20737S Package Dimensions.....	25
Figure 15: BCM20737S Pin Dimensions (Bottom View).....	26

List of Tables

Table 1: 32 kHz Crystal Oscillator Characteristics	8
Table 2: Pin Descriptions	10
Table 3: Absolute Maximum Ratings	14
Table 4: Voltage	14
Table 5: Current Consumption	14
Table 6: Receiver Specifications.....	15
Table 7: Transmitter Specifications.....	15
Table 8: ADC Specifications	16
Table 9: SPI Interface Timing Specifications	18
Table 10: BSC Interface Timing Specifications.....	18
Table 11: UART Timing Specifications	19
Table 12: Pad and Solder Mask Dimensions.....	20
Table 13: Ordering Information	27

About This Document

Purpose and Audience

This document provides descriptions of the interfaces, pin assignments, and specifications of Broadcom® BCM20737S Bluetooth Low Energy (BLE) System-in-Package (SiP) module. It is intended for designers who are responsible for adding the BCM20737S module to wireless input devices including heart-rate monitors, blood pressure monitors, proximity sensors, temperature sensors, and battery monitors.

Acronyms and Abbreviations

In most cases, acronyms and abbreviations are defined on first use.

For a comprehensive list of acronyms and other terms used in Broadcom documents, go to: <http://www.broadcom.com/press/glossary.php>.

Document Conventions

The following conventions may be used in this document:

Convention	Description
Bold	User input and actions: for example, type exit , click OK , press Alt+C
Monospace	Code: #include <iostream> HTML: <td rowspan = 3> Command line commands and parameters: w1 [-1] <command>
< >	Placeholders for <i>required</i> elements: enter your <username> or w1 <command>
[]	Indicates <i>optional</i> command-line parameters: w1 [-1] Indicates bit and byte ranges (inclusive): [0:3] or [7:0]

Technical Support

Broadcom provides customer access to a wide range of information, including technical documentation, schematic diagrams, product bill of materials, PCB layout information, and software updates through its customer support portal (<https://support.broadcom.com>). For a CSP account, contact your Sales or Engineering support representative.

In addition, Broadcom provides other product support through its Downloads and Support site (<http://www.broadcom.com/support/>).

Section 1: Functional Description

External Reset

External reset timing for the BCM20737S is illustrated in [Figure 2](#).

Figure 2: External Reset Timing

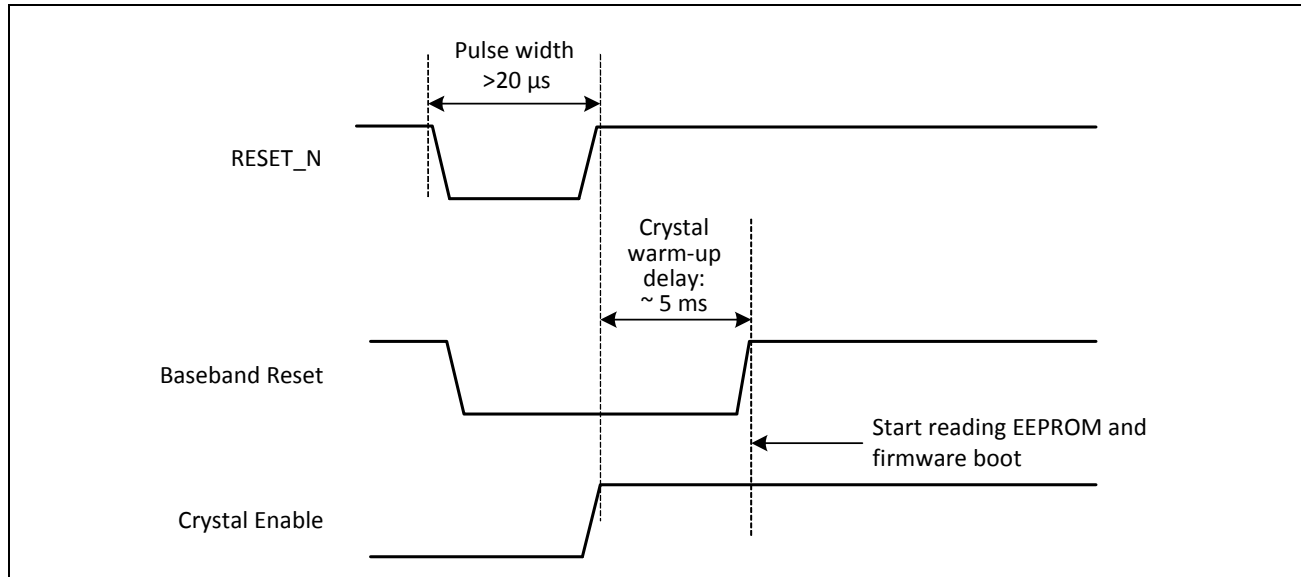

32.768 kHz Oscillator

The BCM20737S includes a standard Pierce oscillator. The oscillator circuit includes a comparator with hysteresis on the output to create a single-ended digital output. The hysteresis eliminates chatter when the input is near the comparator threshold (~100 mV). The oscillator circuit can be designed for a 32 kHz or 32.768 kHz crystal oscillator, and can also be driven by an external clock input with a similar frequency. Characteristics for a 32 kHz oscillator are defined in [Table 1](#).

Table 1: 32 kHz Crystal Oscillator Characteristics

Parameter	Symbol	Conditions	Min.	Typ.	Max.	Unit
Output frequency	F_{oscout}	–	–	32.768	–	kHz
Frequency tolerance	F_{tol}	Crystal-dependent	–	100	–	ppm
Start-up time	$T_{startup}$	–	–	–	500	μs
Crystal drive level	P_{drv}	For crystal selection	0.5	–	–	μW
Crystal series resistance	R_{series}	For crystal selection	–	–	70	kΩ
Crystal shunt capacitance	C_{shunt}	For crystal selection	–	–	1.3	pF

Section 2: Pin Map and Signal Descriptions

The BCM20737S pin map is shown in [Figure 3](#).

Figure 3: BCM20737S (TOP View)

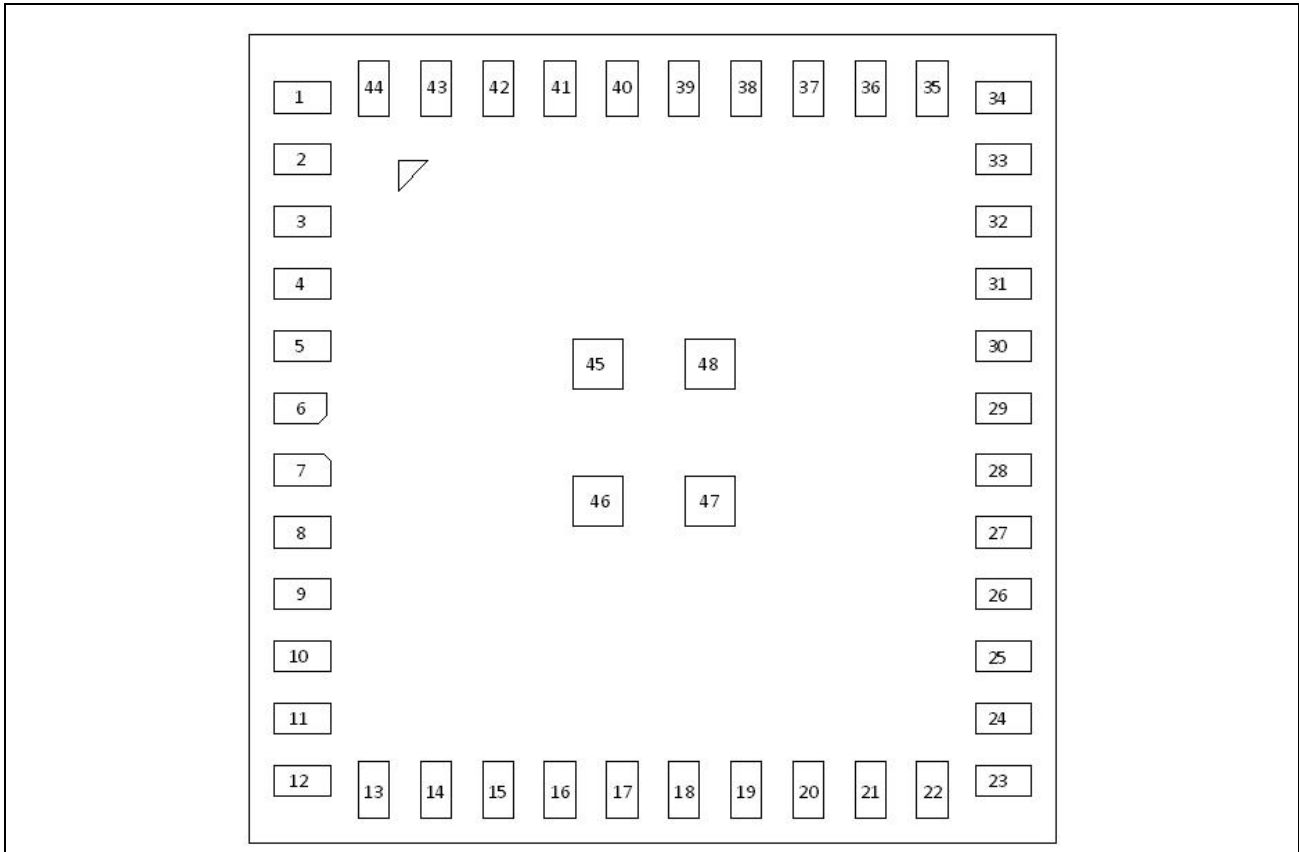

The signal name, type, and description of each pin in the BCM20737S is listed in [Table 2 on page 10](#). The symbols shown under I/O Type indicate pin directions (I/O = bidirectional, I = input, O = output) and the internal pull-up/pull-down characteristics (PU = weak internal pull-up resistor and PD = weak internal pull-down resistor), if any.

Table 2: Pin Descriptions

Pin	Name	I/O Type	Description
1	GPIO: P27 PWM1	I	Default direction: Input. After POR state: Input floating. Drain current: 16 mA Alternate function: MOSI (master and slave) for SPI_2
2	GND	GND	GND
3	VBAT	I	Battery supply input.
4	GND	GND	GND
5	GND	GND	GND
6	GND	GND	GND
7	GND	GND	GND
8	GND	GND	GND
9	GND	GND	GND
10	Reserved	–	Leave floating
11	GND	GND	GND
12	GND	GND	GND
13	GND	GND	GND
14	GND	GND	GND
15	GND	GND	GND
16	GND	GND	GND
17	GND	GND	GND
18	UART_RX	I	UART_RX. This pin is pulled low through an internal 10 kΩ resistor.
19	UART_TX	O, PU	UART_TX
20	GND	GND	GND
21	SCL	I/O, PU	SCL I/O, PU clock signal for an external I ² C device
22	SDA	I/O, PU	SDA I/O, PU data signal for an external I ² C device
23	GND	GND	GND
24	GND	GND	GND
25	GPIO: P1	I	Default direction: Input. After POR state: Input floating. This pin is tied to the WP pin of the embedded EEPROM. Requires an external 10K pull-up
26	TMC	I	Test mode control. Pull this pin high to invoke test mode; leave it floating if not used. This pin is connected to GND through an internal 10 kΩ resistor.
27	RESET_N	I/O PU	Active-low system reset with open-drain output

Table 2: Pin Descriptions (Cont.)

Pin	Name	I/O Type	Description
28	GPIO: P0	I	Default direction: Input. After POR state: Input floating. Alternate functions: <ul style="list-style-type: none"> • A/D converter input • Peripheral UART TX (PUART_TX) • MOSI (master and slave) for SPI_2 • IR_RX • 60Hz_main
29	GND	GND	GND
30	GPIO: P3	I	Default direction: Input. After POR state: Input floating. Alternate functions: <ul style="list-style-type: none"> • Peripheral UART CTS (PUART_CTS) • SPI_CLK (master and slave) for SPI_2
31	GPIO: P2	I	Default direction: Input. After POR state: Input floating. Alternate functions: <ul style="list-style-type: none"> • Peripheral UART RX (PUART_RX) • SPI_CS (slave only) for SPI_2 • SPI_MOSI (master only) for SPI_2
32	GPIO: P4	I	Default direction: Input. After POR state: Input floating. Alternate functions: <ul style="list-style-type: none"> • Peripheral UART RX (PUART_RX) • MOSI (master and slave) for SPI_2. • IR_TX
33	GPIO: P8	I	Default direction: Input. After POR state: Input floating. Alternate functions: A/D converter input.
34	GPIO: P33	I	Default direction: Input. After POR state: Input floating. Alternate functions: <ul style="list-style-type: none"> • A/D converter input • MOSI (slave only) for SPI_2 • Auxiliary clock output (ACLK1) • Peripheral UART RX (PUART_RX)

Table 2: Pin Descriptions (Cont.)

Pin	Name	I/O Type	Description
35	GPIO: P32	I	Default direction: Input. After POR state: Input floating. Alternate functions: <ul style="list-style-type: none"> • A/D converter input • SPI_CS (slave only) for SPI_2. • Auxiliary clock output (ACLK0) • Peripheral UART TX (PUART_TX)
36	GPIO: P25	I	Default direction: Input. After POR state: Input floating. Alternate functions: <ul style="list-style-type: none"> • MISO (master and slave) for SPI_2 • Peripheral UART RX (PUART_RX)
37	GPIO: P24	I	Default direction: Input. After POR state: Input floating. Alternate functions: <ul style="list-style-type: none"> • SPI_CLK (master and slave) for SPI_2 • Peripheral UART TX (PUART_TX)
38	NC	NC	No Connection (N/C).
39	GPIO: P13 PWM3	I	Default Direction: Input After POR State: Input Floating Drain current: 16 mA Alternate function: A/D converter input
	GPIO: P28 PWM2	I	Default direction: Input. After POR state: Input floating. Drain current: 16 mA Alternate functions: <ul style="list-style-type: none"> • A/D converter input • LED1 • IR_TX
40	GPIO: P14 PWM2	I	Default direction: Input. After POR state: Input floating. Alternate function: A/D converter input
	GPIO: P38	I	Default direction: Input. After POR state: Input floating. Alternate functions: <ul style="list-style-type: none"> • A/D converter input • MOSI (master and slave) for SPI_2 • IR_TX

Table 2: Pin Descriptions (Cont.)

Pin	Name	I/O Type	Description
41	GPIO: P15	I	Default direction: Input. After POR state: Input floating. Alternate functions: <ul style="list-style-type: none"> • A/D converter input • IR_RX • 60 Hz_main
42	GPIO: P26 PWM0	I	Default direction: Input. After POR state: Input floating. Drain current: 16 mA Alternate function: SPI_CS (slave only) for SPI_2
43	GPIO: P12	I	Default direction: Input. After POR state: Input floating. Alternate functions: <ul style="list-style-type: none"> • A/D converter input • XTALO32K
	XTALO32K	O	Low-power oscillator (LPO) output. Alternate functions: <ul style="list-style-type: none"> • P12 • P26
44	GPIO: P11	I	Default direction: Input. After POR state: Input floating. Alternate functions: <ul style="list-style-type: none"> • A/D converter input • XTALI32K
	XTALI32K	I	Low-power oscillator (LPO) input. Alternate functions: <ul style="list-style-type: none"> • P11 • P27
45	GND	GND	GND
46	GND	GND	GND
47	GND	GND	GND
48	GND	GND	GND

Section 3: Electrical Specifications

Absolute maximum ratings are defined in [Table 3](#).

Table 3: Absolute Maximum Ratings

Parameter	Min.	Max.	Unit
Supply power	NA	3.63	V
Storage temperature	-40	125	°C
Voltage ripple	0	±2	%
Power supply (VBAT absolute maximum rating)	1.62	3.63	V

Power for the BCM20737S module is provided by the host through the power pins.

Table 4: Voltage

Symbol	Parameter	Min.	Typ.	Max.	Unit
VBAT	Battery voltage	1.62	–	3.63	V

Table 5: Current Consumption

Operating Mode	Condition	Nominal	Maximum	Unit
Receive	Receiver and baseband are both operating, 100%	24.0	28.0	mA
Transmit	Transmitter and baseband are both operating, 100%	24.0	28.0	mA
Sleep	Wake in < 5 ms	55.0	60.0	µA
Deep Sleep	Wake on interrupt	2.0	2.5	µA

Note: All measurements taken at 25°C

Based on the current measurements in [Table 5 on page 14](#), BCM20737S peak power values are:

- RX: 101.6 mW
- TX: 101.6 mW
- Sleep mode: 217.8 µW
- Deep Sleep mode: 9.1 µW

Section 4: RF Specifications

BCM20737S receiver specifications are defined in [Table 6](#).

Table 6: Receiver Specifications

Parameter	Mode and Conditions	Min.	Typ.	Max.	Unit
Frequency range	–	2402	–	2480	MHz
RX sensitivity (standard)	Packets: 200 Payload: PRBS 9 Length: 37 Bytes Dirty Transmitter: off. PER: 30.8%	–	–94	–	dBm
Maximum input	–	–10	–	–	dBm

Note: All measurements taken at 3.0V (default voltage)

RF transmitter specifications are defined in [Table 7](#).

Table 7: Transmitter Specifications

Parameter	Min.	Typ.	Max.	Unit
Transmitter				
Frequency range ^a	2402	–	2480	MHz
Output power adjustment range	–20	–	4	dBm
Output power	–	2	–	dBm
Output power variation	–	2.5	–	dB
LO Performance				
Initial carrier frequency tolerance	–	–	±150	kHz
Frequency Drift				
Frequency drift	–	–	±50	kHz
Drift rate	–	–	20	kHz/50 μ s
Frequency Deviation				
Average deviation in payload (sequence: 00001111)	225	–	275	kHz
Average deviation in payload (sequence: 10101010)	185	–	–	kHz
Channel spacing	–	2	–	MHz

a. This parameter is taken from the Bluetooth 4.0 specification.

Section 5: ADC Specifications

BCM20737S ADC specifications are defined in [Table 8](#).

Table 8: ADC Specifications

Parameter	Symbol	Conditions	Min.	Typ.	Max.	Unit
Number of input channels	–	–	–	9	–	–
Channel switching rate	f_{ch}	–	–	–	133.33	Kch/s
Input signal range	V_{inp}	–	0	–	3.63	V
Reference settling time	–	Charging refsel	7.5	–	–	μ s
Input resistance	R_{inp}	Effective, single-ended	–	500	–	k Ω
Input capacitance	C_{inp}	–	–	–	5	pF
Conversion rate	F_c	–	5.859	–	187	kHz
Conversion time	T_c	–	5.35	–	170.7	μ s
Resolution	R	–	–	16	–	Bits
Absolute voltage measurement error	–	Using on–chip ADC firmware driver	–	± 2	–	%
Current	I	$I_{avdd1p2} + I_{avdd3p3}$	–	–	1	mA
Power	P	–	–	1.5	–	mW
Leakage Current	$I_{leakage}$	T = 25°C	–	–	100	nA
Power-up time	$T_{powerup}$	–	–	–	200	μ s
Integral nonlinearity	I_{NL}	In the guaranteed performance range	–1	–	1	LSB ^a
Differential nonlinearity	D_{NL}	In the guaranteed performance range	–1	–	1	LSB ^a

a. LSBs are expressed at the 10-bit level.

Section 6: Timing and AC Characteristics

SPI Timing

SPI interface timing is illustrated in [Figure 4](#) and [Figure 5](#) and defined in [Table 9](#) on page 18.

Figure 4: SPI Timing—Modes 0 and 2

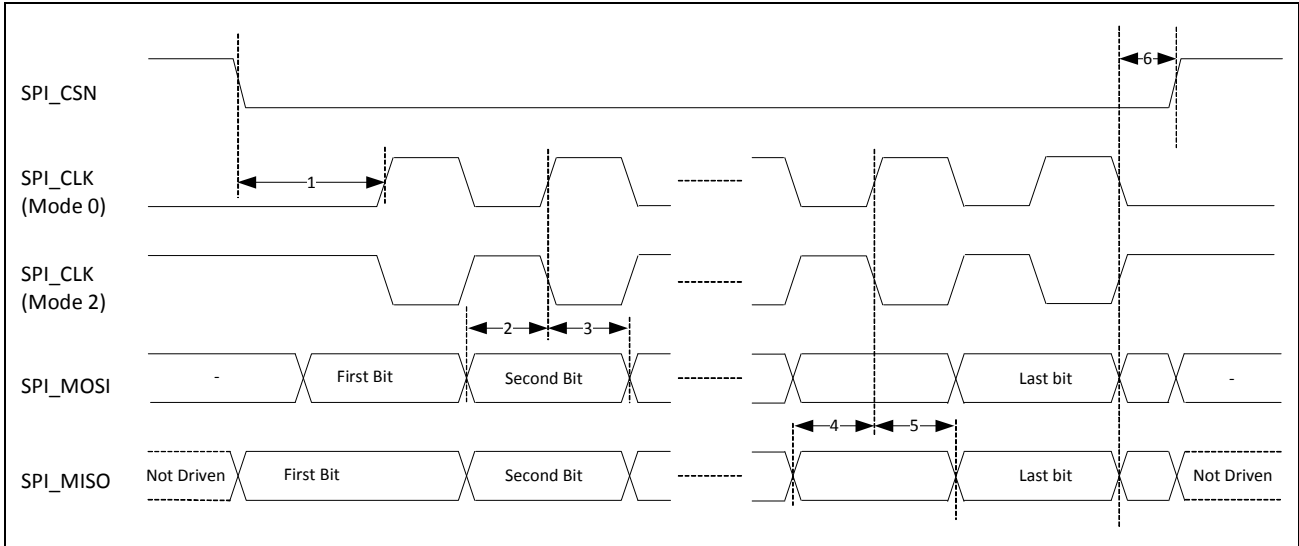

Figure 5: SPI Timing—Modes 1 and 3

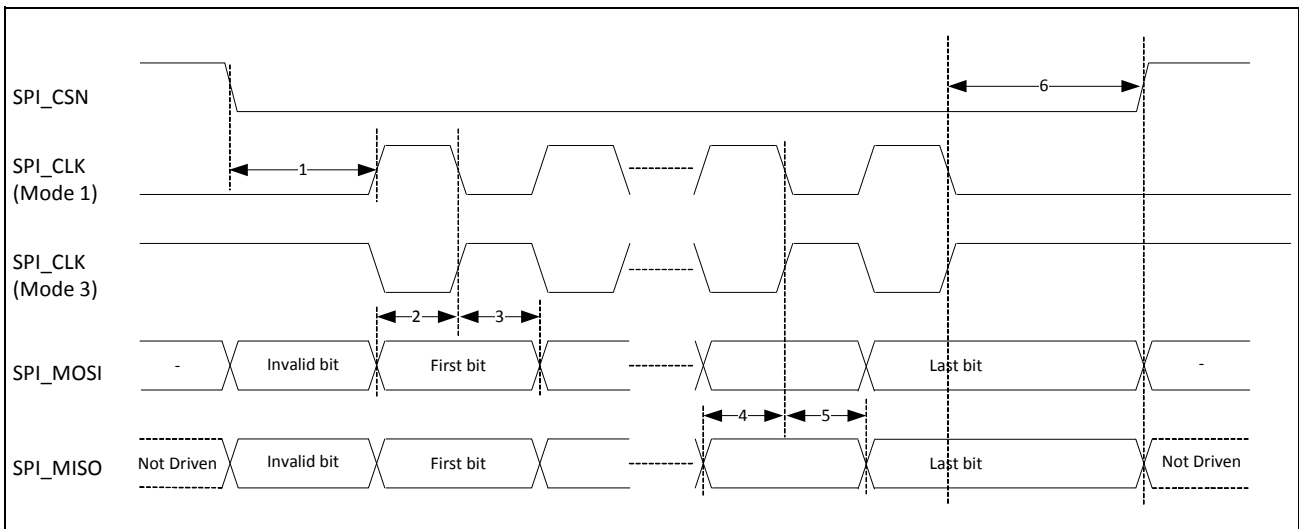

Table 9: SPI Interface Timing Specifications

Reference	Characteristics	Min.	Typ.	Max.
1	Time from CSN asserted to first clock edge	1 SCK	100	∞
2	Master setup time	–	1/2SCK	–
3	Master hold time	1/2SCK	–	–
4	Slave setup time	–	1/2 SCK	–
5	Slave hold time	1/2 SCK	–	–
6	Time from last clock edge to CSN deasserted	SCK	10 SCK	100

BSC Interface Timing

BSC interface timing is illustrated in Figure 6 and is defined in Table 10.

Figure 6: BSC Interface Timing

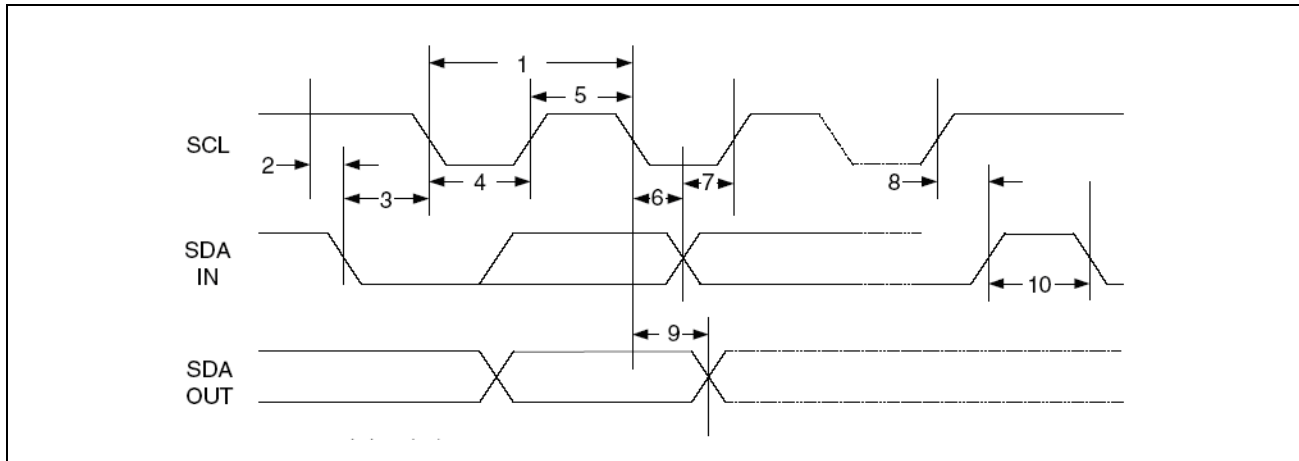

Table 10: BSC Interface Timing Specifications

Reference	Characteristics	Min.	Max.	Unit
1	Clock frequency	–	100, 400, 800, 1000	kHz
2	START condition setup time	650	–	ns
3	START condition hold time	280	–	ns
4	Clock low time	650	–	ns
5	Clock high time	280	–	ns
6	Data input hold time	0	–	ns
7	Data input setup time	100	–	ns
8	STOP condition setup time	280	–	ns
9	Output valid from clock	–	400	ns
10	Bus free time	650	–	ns

UART Timing

UART timing is illustrated in [Figure 7](#) and defined in [Table 11](#).

Figure 7: UART Timing

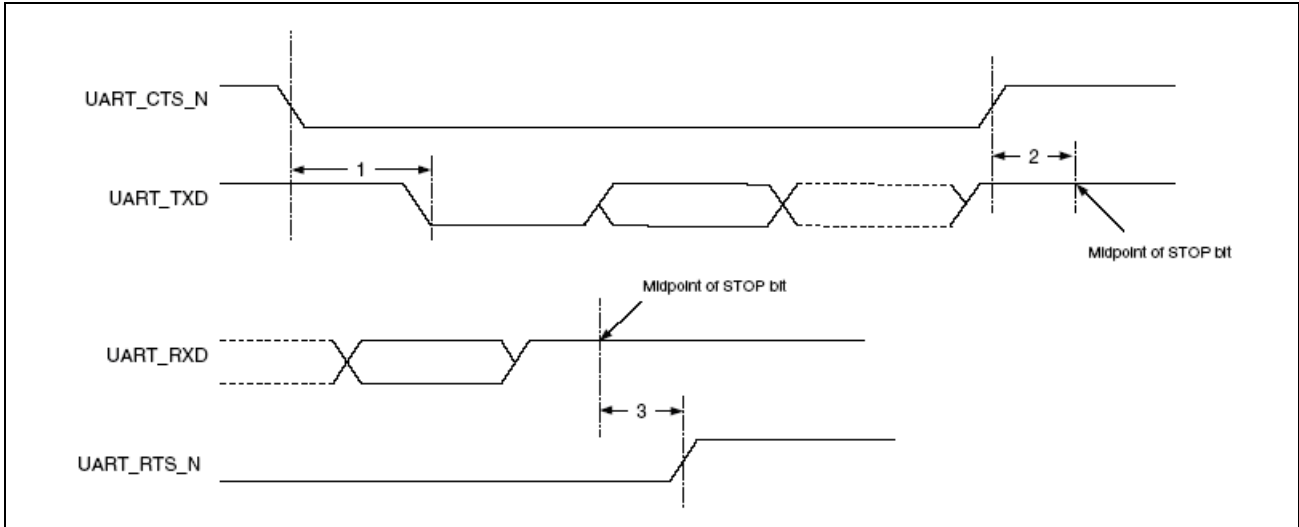

Table 11: UART Timing Specifications

Reference	Characteristics	Min.	Max.	Unit
1	Delay time, UART_CTS_N low to UART_TXD valid	–	24	Baudout cycles
2	Setup time, UART_CTS_N high before midpoint of stop bit	–	10	ns
3	Delay time, midpoint of stop bit to UART_RTS_N high	–	2	Baudout cycles

Section 7: PCB Design and Manufacturing Recommendations

Pad and Solder Mask Opening Dimensions

BCM20737S pad and solder mask opening dimensions are defined in [Table 12](#).

Table 12: Pad and Solder Mask Dimensions

<i>Pad Type</i>	<i>Pad Dimensions</i>	<i>Solder Mask Opening Dimensions</i>	<i>Unit</i>
Type A	0.6 × 0.25	0.7 × 0.35	mm
Type B	0.55 × 0.3	0.65 × 0.4	
Type C	0.4 × 0.4	0.5 × 0.5	

PCB Layout Recommendations

The following layout recommendations are referenced to [Figure 8 on page 21](#).

- Connect to system ground from side D of the module (pins 13–22).
- The L-shaped ground plane is required for the embedded BLE antenna. Keep the GND continuous. Do not cut off the GND shape to accommodate trace routes.
- An L-shaped ground plane is required. If the L-shaped GND plane is located on the top layer of the PCB, do not place components on the ground plane. If this cannot be avoided, move the L-shaped ground plane to another layer.
- Antenna efficiency of 31–41% can be achieved based on the layout in [Figure 8 on page 21](#) and the dimensions listed below. Following these layout recommendations is expected to yield 50+ meters of usable range; deviating from these recommendations may reduce the range of the antenna.
 - D: 4.5 mm (typical)
 - G, H, S: 3 mm (typical)
 - L: 3 mm (minimum)
 - W: 0.4 mm (typical)
- Route signal traces out of the module from side C (between pins 27 and 30) or side D (between pins 16 and 19) of the module. Traces can be overlapped to avoid routing through the keep-out area.
- Do not route traces from side A or side B.

Figure 8: PCB Layout Example

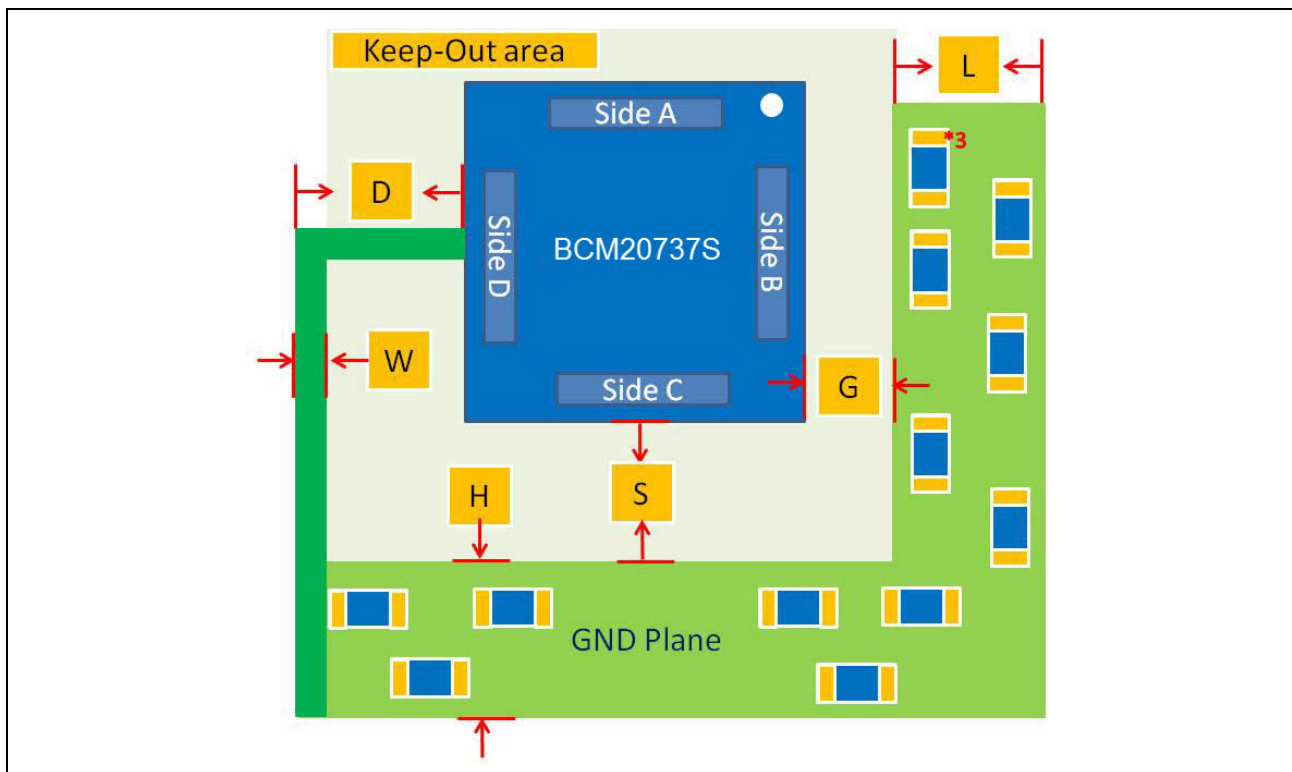

PCB Stencil

The recommended PCB stencil is shown in [Figure 9](#) (all measurements in mm). Use an unsolder mask to set the module footprint.

Figure 9: BCM20737S Stencil (Bottom View)

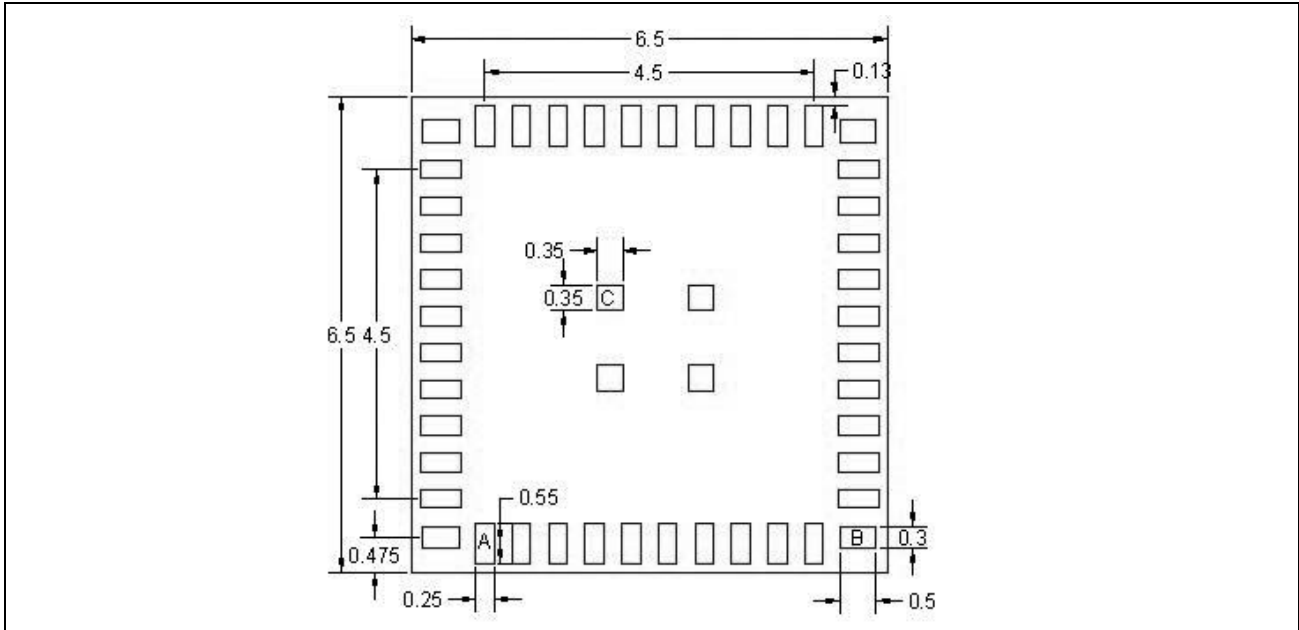

Solder Reflow

The recommended solder reflow profile for the BCM20737S is defined in [Figure 10](#).

Figure 10: Solder Reflow Profile

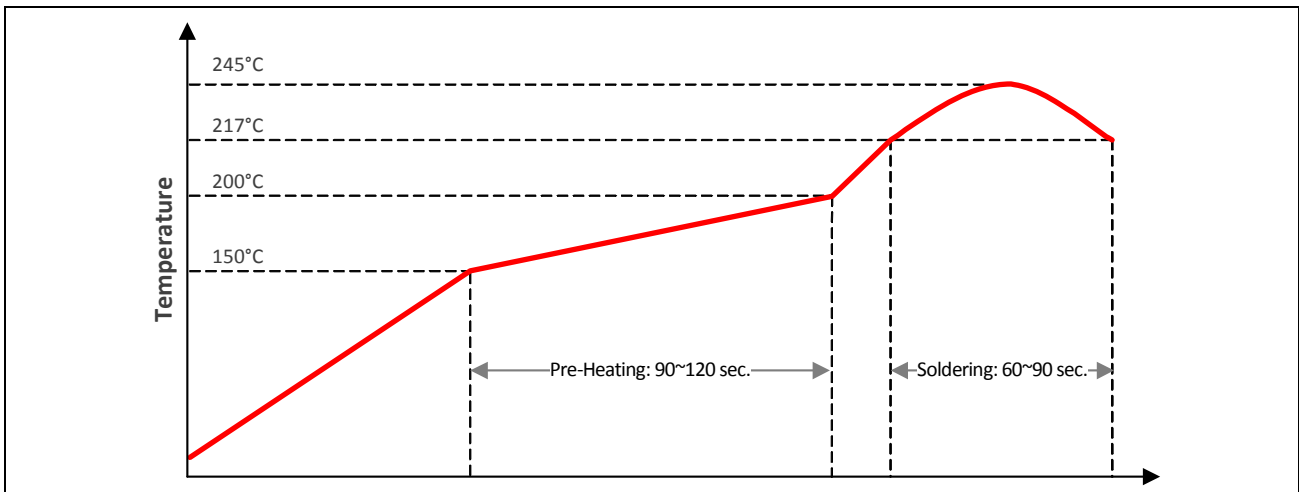

Section 8: Packaging and Storage Information

The BCM20737S is available in a tape and reel package and is shipped in an ESD-protected moisture-resistant (MSL-3) bag as shown in [Figure 11](#). The storage temperature range is -40°C to $+125^{\circ}\text{C}$.

Figure 11: BCM20737S ESD/Moisture Packaging



The moisture sensitivity label on the BCM20737S shipping bag is shown in [Figure 12 on page 24](#).

Figure 12: BCM20737S Moisture Sensitivity Label



Figure 13 shows the location of pin 1 on the BCM20737S relative to its orientation on the tape packaging.

Figure 13: BCM20737S Tape and Reel Pin 1 Location

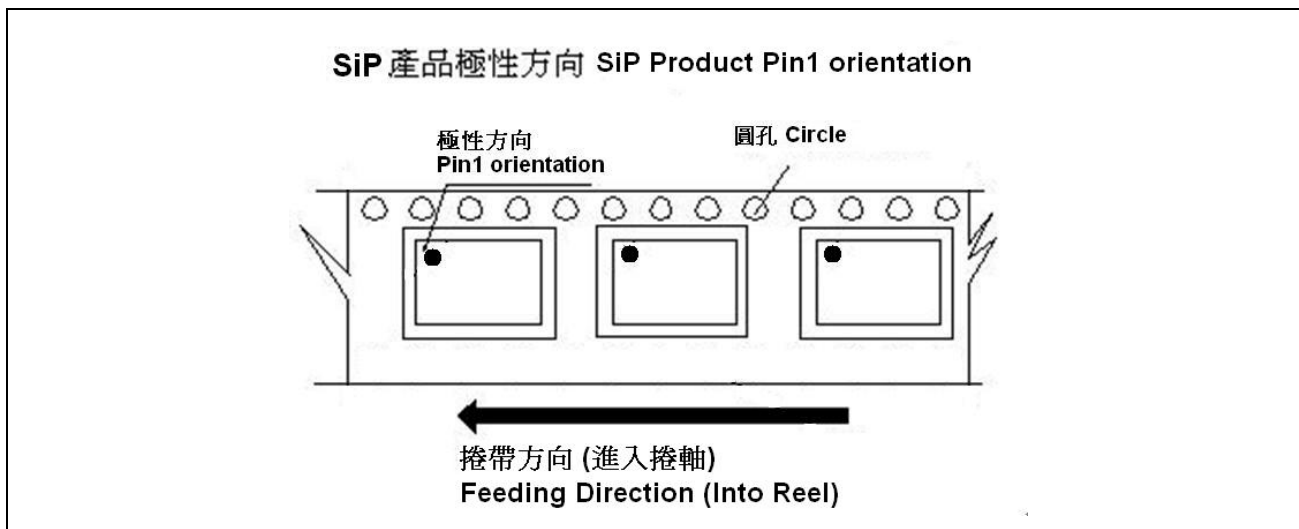

Section 9: Mechanical Information

Package dimensions for the BCM20737S are shown in [Figure 14](#).

Figure 14: BCM20737S Package Dimensions

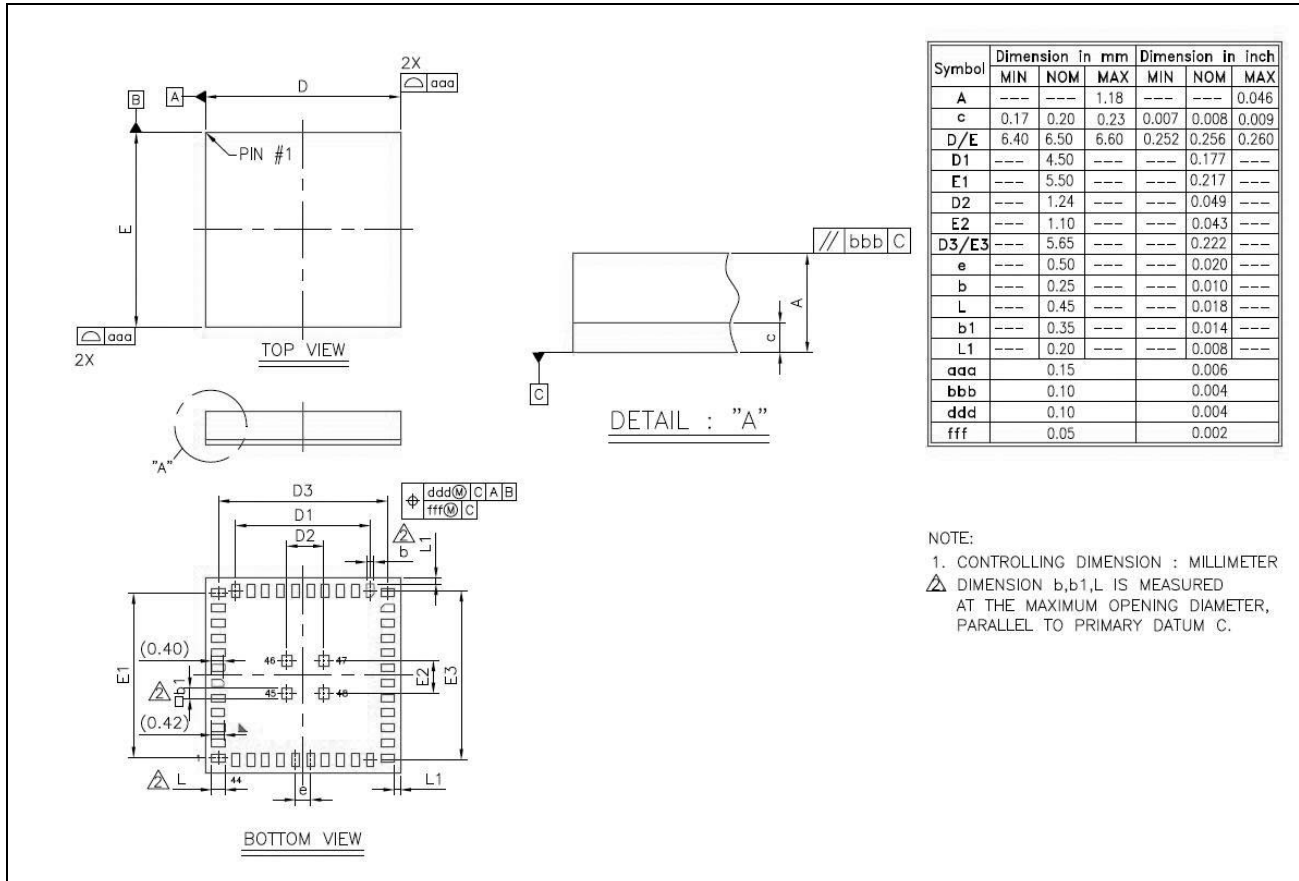

Additional BCM20737S package dimensions are shown in [Figure 15](#) on page 26.

Figure 15: BCM20737S Pin Dimensions (Bottom View)

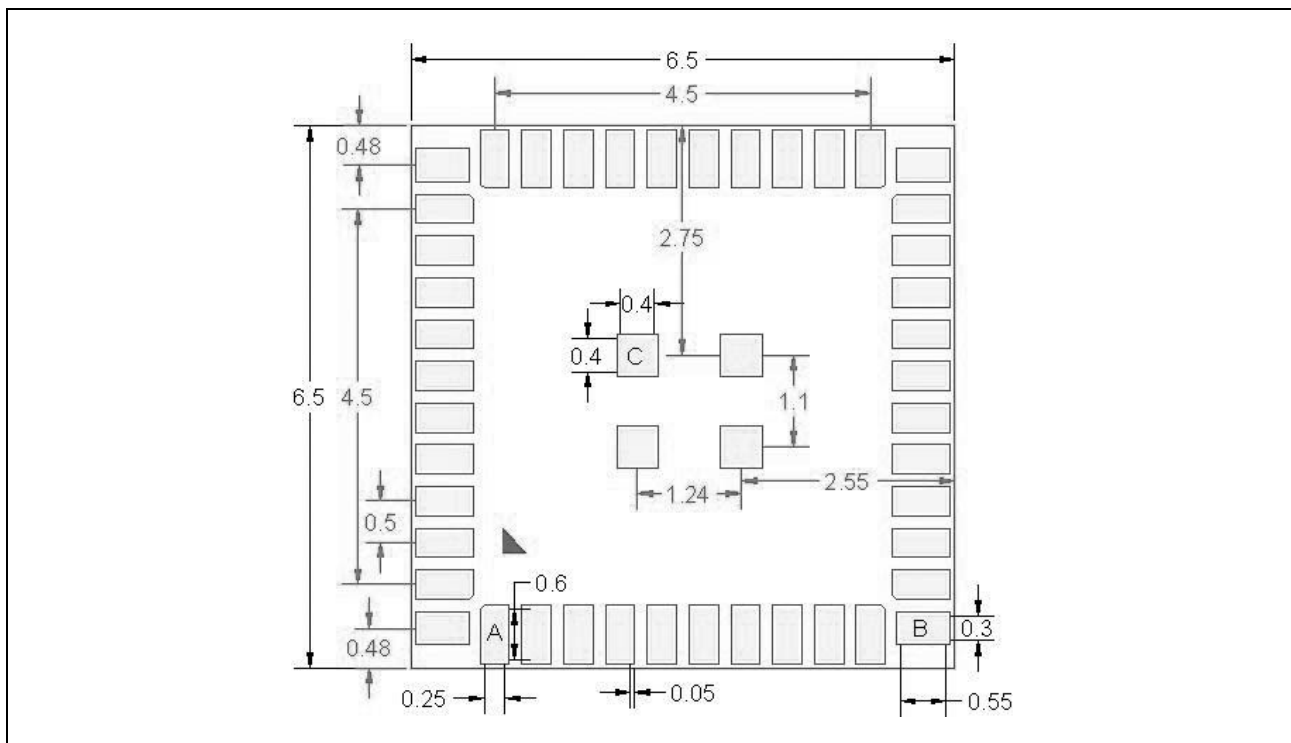

Section 10: Ordering Information

Table 13: Ordering Information

<i>Part Number</i>	<i>Package</i>	<i>Operating Temperature</i>	<i>Humidity</i>
BCM20737S	48-pin LGA	-40°C to +85°C	95% max., noncondensing

Broadcom® reserves the right to make changes without further notice to any products or data herein to improve reliability, function, or design.

Information furnished by Broadcom is believed to be accurate and reliable. However, Broadcom does not assume any liability arising out of the application or use of this information, nor the application or use of any product or circuit described herein, neither does it convey any license under its patent rights nor the rights of others.



Broadcom

Web: www.broadcom.com

Corporate Headquarters: San Jose, CA

© 2016 by Broadcom. All rights reserved.

20737S-DS101-R April 10, 2016

X-ON Electronics

Largest Supplier of Electrical and Electronic Components

Click to view similar products for [Bluetooth Modules - 802.15.1 category](#):

Click to view products by [Cypress manufacturer](#):

Other Similar products are found below :

[A2541R24A10GM](#) [CYBLE-212023-10](#) [BM78SPP05NC2-0002AA](#) [BM78SPP05MC2-0002AA](#) [CYW20732S](#) [968EMB0019](#) [E73-2G4M08S1CX](#) [TB-03F-AT_Mesh](#) [TB-04](#) [TB-04--AT_Mesh](#) [BT3L\(jibu\)](#) [BT5S\(xoft\)](#) [BT5S\(4k43\)](#) [BT5S\(jcyv\)](#) [1327](#) [RN42HID-I/RM](#) [BM70BLE01FC2-0B03AA](#) [ACN52832](#) [A2541E24A10GM](#) [RN42-I/RM630](#) [MOTG-BLUETOOTH](#) [ABBTM-2.4GHz-52-T](#) [ABBTM-2.4GHz-T](#) [ABBTM-2.4GHz-T2](#) [ACN52840](#) [AFERO-BL24-01](#) [BLED112](#) [BM62SPKS1MC2-0001AA](#) [BM78SPPS5MC2-0002AA](#) [PX0880/1](#) [BM833F](#) [BT680F](#) [PBA31309V1.00](#) [S LK64](#) [ATSAMB11-MR510CA](#) [BM20SPKS1NBC-0001AA](#) [BM23SPKS1NB9-0B02AA](#) [BM70BLE01FC2-0B04AA](#) [BM70BLES1FC2-0B04AA](#) [BM77SPP03MC2-0008AA](#) [BM77SPPS3MC2-0007AA](#) [BM78SPPS5NC2-0002AA](#) [DM164146](#) [RN42-I/RM615](#) [RN42N-I/RM](#) [RN42NU-IRM](#) [RN42XVP-I/RM](#) [RN4678-V/RM113](#) [RN4871U-V/RM118](#) [ENW-89820A3KF](#) [ENW-89846A1KF](#)