

# Quad PLL Programmable Clock Generator with Spread Spectrum

## Features

- Four fully integrated phase-locked loops (PLLs)
- Input Frequency range:
  - External crystal: 8 to 48 MHz
  - External reference: 8 to 166 MHz clock
- Wide operating output frequency range
  - 3 to 166 MHz
- Programmable Spread Spectrum with Center and Down Spread option and Lexmark modulation profile
- Two VDD core voltage options:
  - 2.5V, 3.0V, and 3.3V for CY2544
  - 1.8V for CY2546
- Selectable output voltages:
  - 2.5V, 3.0V, and 3.3V for CY2544
  - 1.8V for CY2546
- Frequency Select feature with option to select eight different frequencies
- Low jitter, high accuracy outputs
- Up to nine clock outputs
- Programmable output drive strength
- Glitch-free outputs while frequency switching
- 24-pin QFN package
- Commercial and Industrial temperature ranges

## Benefits

- Multiple high-performance PLLs allow synthesis of unrelated frequencies
- Nonvolatile programming for customized PLL frequencies, spread spectrum characteristics, drive strength, crystal load capacitance, and output frequencies
- Two Spread Spectrum capable PLLs with Linear or Lexmark profile for maximum EMI reduction
- Spread Spectrum PLLs can be disabled or enabled separately
- PLLs can be programmed for system frequency margin tests
- Meets critical timing requirements in complex system designs
- Suitable for PC, consumer, and networking applications
- Ability to synthesize standard frequencies with ease
- Application compatibility in standard and low-power systems

## Block Diagram

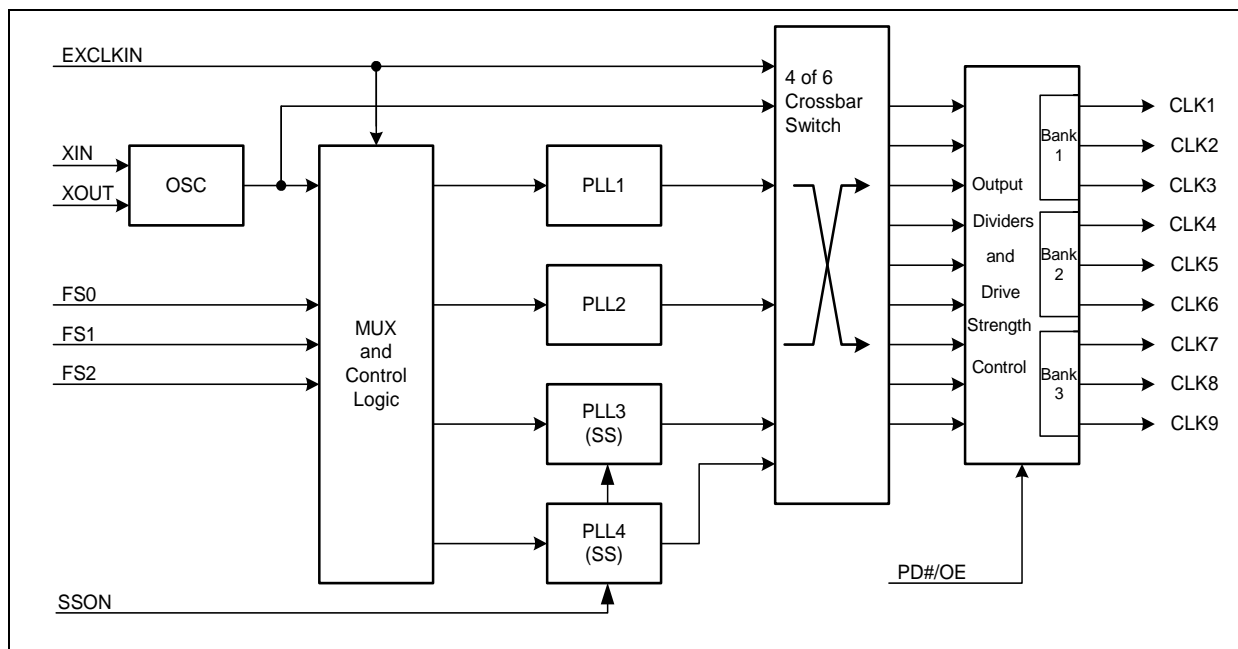

### Pin Configuration

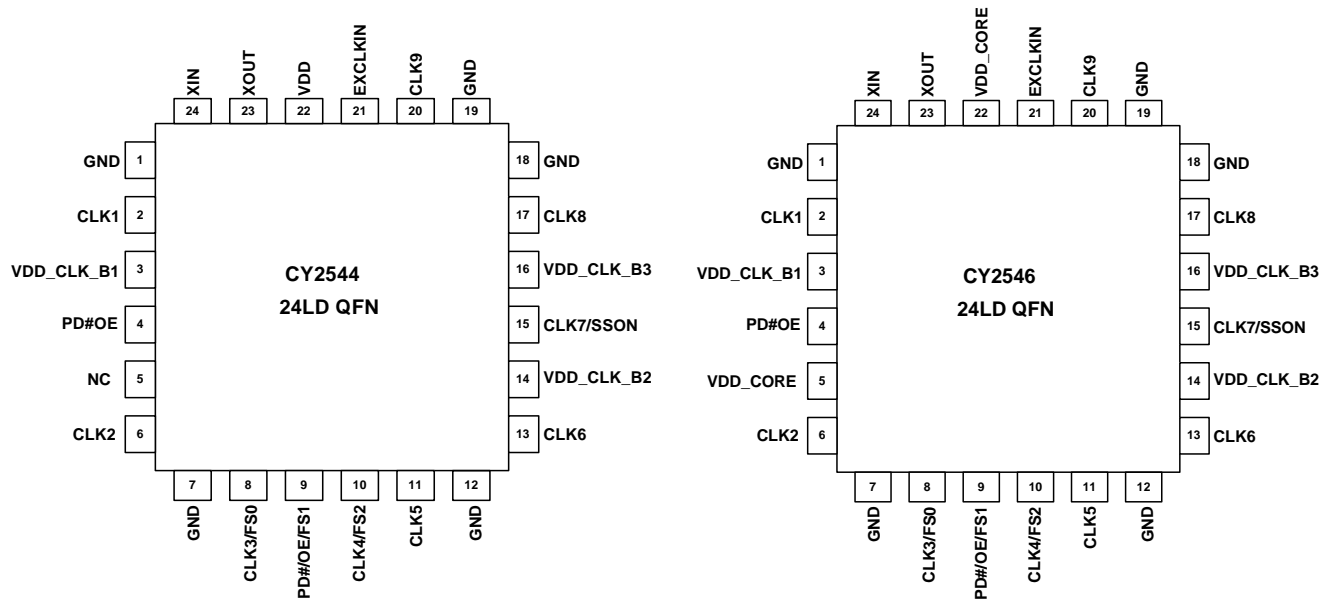

### Pin Description - CY2544 (2.5V, 3.0V or 3.3V VDD)

Pin Number	Name	I/O	Description
1	GND	Power	Power Supply Ground for Core
2	CLK1	Output	Programmable Output Clock
3	VDD_CLK_B1	Power	2.5V/3.0V/3.3V Power Supply for Output Bank1 (CLK1, CLK2, CLK3) output
4	PD#/OE	Input	Power Down or Output Enable
5	NC	NC	No Connect
6	CLK2	Output	Programmable Output Clock
7	GND	Power	Power Supply Ground for Output Bank 1
8	CLK3/FS0	Output/Input	Multifunction Programmable pin,CLK3 Output Clock or Frequency Select pin FS0
9	PD#/OE/FS1	Input	Multifunction Programmable pin, Power Down, Output Enable or Frequency Select pin FS1
10	CLK4/FS2	Output/Input	Multifunction Programmable pin, CLK4 Output or Frequency Select input pin FS2
11	CLK5	Output	Programmable Output Clock
12	GND	Power	Power Supply Ground for Output Bank 2
13	CLK6	Output	Programmable Output Clock
14	VDD_CLK_B2	Power	2.5V/3.0V/3.3V Power Supply for Output Bank2 (CLK4, CLK5, CLK6) output
15	CLK7/SSON	Output/Input	Multifunction Programmable pin, CLK7 Output or SSON input
16	VDD_CLK_B3	Power	2.5V/3.0V/3.3V Power Supply for Output Bank3 (CLK7, CLK8, CLK9) output
17	CLK8	Output	Programmable Output Clock
18	GND	Power	Power Supply Ground for Output Bank 3

**Pin Description - CY2544 (2.5V, 3.0V or 3.3V VDD) (continued)**

Pin Number	Name	I/O	Description
19	GND	Power	Power Supply Ground for Core
20	CLK9	Output	Programmable Output Clock
21	EXCLKIN	Input	External Clock Input
22	VDD	Power	2.5V/3.0V/3.3V Power Supply
23	XOUT	Output	Crystal Output
24	XIN	Input	Crystal Input

**Pin Description - CY2546 (1.8V VDD\_CORE)**

Pin Number	Name	I/O	Description
1	GND	Power	Power Supply Ground for Core
2	CLK1	Output	Programmable Output Clock
3	VDD_CLK_B1	Power	1.8V Power Supply for Output Bank1 (CLK1, CLK2, CLK3) output
4	PD#/OE	Input	Power Down or Output Enable
5	VDD_CORE	Power Supply	1.8V Power Supply for Core
6	CLK2	Output	Programmable Output Clock
7	GND	Power	Power Supply Ground For Output Bank 1
8	CLK3/FS0	Output/Input	Multifunction Programmable pin, CLK3 Output Clock or Frequency Select pin FS0
9	PD#/OE/FS1	Input	Multifunction Programmable pin, Power Down, Output Enable or Frequency Select pin FS1
10	CLK4/FS2	Output/Input	Multifunction Programmable pin, CLK4 Output or Frequency Select input pin FS2
11	CLK5	Output	Programmable Output Clock
12	GND	Power	Power Supply Ground for Output Bank 2
13	CLK6	Output	Programmable Output Clock
14	VDD_CLK_B2	Power	1.8V Power Supply for Output Bank2 (CLK4, CLK5, CLK6) output
15	CLK7/SSON	Output/Input	Multifunction Programmable pin, CLK4 Output or SSON input
16	VDD_CLK_B3	Power	1.8V Power Supply for Output Bank3 (CLK7, CLK8, CLK9) output
17	CLK8	Output	Programmable Output Clock
18	GND	Power	Power Supply Ground for Output Bank 3
19	GND	Power	Power Supply Ground for Core
20	CLK9	Output	Programmable Output Clock
21	EXCLKIN	Input	External Low Voltage Reference Clock Input
22	VDD_CORE	Power	1.8V Power Supply for Core
23	XOUT	Output	Crystal Output
24	XIN	Input	Crystal Input

## General Description

The CY2544 and CY2546 are four-PLL programmable Spread Spectrum Clock Generators used to reduce EMI found in high-speed digital electronic systems. Two of the four PLLs have Spread Spectrum capability. The spread spectrum feature is turned on or off using the control pin SSON.

The advantage of having four PLLs is that a single device can generate up to four independent families of frequencies from a single crystal or reference input frequency. Generally, a design requires up to four oscillators to achieve the same result as a single CY2544 or CY2546.

The device uses Cypress proprietary PLL and Spread Spectrum Clock (SSC) technology to synthesize and modulate the frequency of the input clock. Frequency modulating the clock greatly reduces the measured EMI at the fundamental and harmonic frequencies. This reduction in radiated energy significantly reduces the cost of complying with regulatory agency (EMC) requirements and improves time-to-market without degrading the system performance.

The CY2544 and CY2546 use a factory/field-programmable configuration memory array to provide customization for output frequencies, frequency select options, spread characteristics like spread percentage and modulation frequency, output drive strength and crystal load capacitance. Customized devices are configured using CyberClocks™ software or by contacting the factory.

The spread percentage is programmed to either center spread or down spread with various spread percentages. The range for center spread is from  $\pm 0.125\%$  to  $\pm 2.50\%$ . The range for down spread is from  $-0.25\%$  to  $-5.0\%$ . Contact the factory for smaller or larger spread percentage amounts, if required.

The input to the CY2544 and CY2546 is either a crystal or a clock signal. The input frequency range for crystals is 8 MHz to 48 MHz, and for clock signals is 8 MHz to 166 MHz. In addition, there is a separate input for a clock reference.

The CY2544 and CY2546 have nine clock outputs and each output has four possible input sources. There are three frequency select lines FS(2:0) that provide an option to select eight different sets of frequencies among each of the four PLLs. Each output has programmable output divider options. Output 1 has eight possible divider values and outputs 2–9 have four possible divider values for maximum flexibility. The 2-bit or 3-bit output dividers are programmable, providing a wide output frequency range.

The outputs are glitch-free when frequency is switched using output dividers. The outputs can have a predictable phase relationship, if the clock source is the same PLL and divider values are 2, 3, 4, or 6.

The output banking feature allows the three sets of frequencies to operate at three different voltages. Selectable output voltage options are 2.5V, 3.0V, or 3.3V for CY2544 and 1.8V for CY2546 part.

The CY2544 and CY2546 are available in 24-pin QFN packages with commercial and industrial operating temperature ranges.

**Table 1. Supply Voltage Options**

Device	V <sub>DD</sub> Supply Voltage
CY2544	2.5V, 3.0V or 3.3V
CY2546	1.8V

### Absolute Maximum Conditions

Parameter	Description	Condition	Min.	Max.	Unit
V <sub>DD</sub>	Supply Voltage for CY2544		-0.5	4.5	V
V <sub>DD_CORE</sub>	Supply Voltage for CY2546		-0.5	2.6	V
V <sub>DD_CLK_BX</sub>	Supply Voltage for CY2544		-0.5	4.5	V
	Supply Voltage for CY2546		-0.5	2.6	V
V <sub>IN</sub>	Input Voltage	Relative to V <sub>SS</sub>	-0.5	V <sub>DD</sub> + 0.5	VDC
T <sub>S</sub>	Temperature, Storage	Non Functional	-65	+150	°C
ESD <sub>HBM</sub>	ESD Protection (Human Body Model)	MIL-STD-883, Method 3015	2000	-	Volts
UL-94	Flammability Rating	@ 1/8 in.	V-0		
MSL	Moisture Sensitivity Level	QFN package	3		

### Recommended Operating Conditions

Parameter	Description	Min.	Typ.	Max.	Unit
V <sub>DD</sub>	VDD Operating at 3.3V for CY2544	3.00	-	3.60	V
V <sub>DD</sub>	VDD Operating at 3.0V for CY2544	2.70	-	3.30	V
V <sub>DD</sub>	VDD Operating at 2.5V for CY2544	2.25	-	2.75	V
V <sub>DD_CORE</sub>	VDD_CORE Operating at 1.8V for CY2546	1.65	-	1.95	V
V <sub>DD_CLK_BX</sub>	Output Driver Voltage for Bank 1, 2 and 3 Operating at 3.3V (CY2544)	3.00	-	3.60	V
V <sub>DD_CLK_BX</sub>	Output Driver Voltage for Bank 1, 2 and 3 Operating at 3.0V (CY2544)	2.70	-	3.30	V
V <sub>DD_CLK_BX</sub>	Output Driver Voltage for Bank 1, 2 and 3 Operating at 2.5V (CY2544)	2.25	-	2.75	V
V <sub>DD_CLK_BX</sub>	Output Driver Voltage for Bank 1, 2 and 3 Operating at 1.8V (CY2546)	1.65	-	1.95	V
T <sub>AC</sub>	Commercial Ambient Temperature	0	-	+70	°C
T <sub>AI</sub>	Industrial Ambient Temperature	-40	-	+85	°C
C <sub>LOAD</sub>	Maximum Load Capacitance	-	-	15	pF
t <sub>PU</sub>	Power-up time for all V <sub>DD</sub> pins to reach minimum specified voltage (power ramps must be monotonic)	0.05	-	500	ms

### DC Electrical Specifications

Parameter	Description	Conditions	Min.	Typ.	Max.	Unit
V <sub>OL</sub>	Output Low Voltage, All CLK pins	All V <sub>DD</sub> levels, I <sub>OL</sub> = 8 mA	-	-	0.4	V
V <sub>OH</sub>	Output High Voltage, All CLK pins	All V <sub>DD</sub> levels, I <sub>OH</sub> = -8 mA	V <sub>DD</sub> - 0.4	-	-	V
V <sub>IL</sub>	All Inputs except XIN	All V <sub>DD</sub> levels	-0.3	-	0.2 * V <sub>DD</sub>	V
V <sub>IH</sub>	All Inputs except XIN	All V <sub>DD</sub> levels	0.8 * V <sub>DD</sub>	-	V <sub>DD</sub> + 0.3	V
V <sub>ILX</sub>	Input Low Voltage, clock input to XIN pin	All V <sub>DD</sub> levels	-0.3	-	0.36	V
V <sub>IHX</sub>	Input High Voltage, clock input to XIN pin	All V <sub>DD</sub> levels	1.44	-	2.0	V
I <sub>ILPDOE</sub>	Input Low Current, PD#/OE and FS0,1,2 pins	V <sub>IN</sub> = V <sub>SS</sub> (No Internal pull up)	-	-	1	μA
I <sub>IHPDOE</sub>	Input High Current, PD#/OE and FS0,1,2 pins	V <sub>IN</sub> = V <sub>DD</sub> (No Internal pull up)	-	-	1	μA
I <sub>ILSR</sub>	Input Low Current, SSON pin	V <sub>IN</sub> = V <sub>SS</sub> (Internal pull down = 160k typical)	-	-	1	μA
I <sub>IHSR</sub>	Input High Current, SSON pin	V <sub>IN</sub> = V <sub>DD</sub> (Internal pull down = 160k typical)	-	-	25	μA
I <sub>DD</sub> <sup>[1]</sup>	Supply Current	All clocks running, No load	-	15	-	mA
I <sub>DDS</sub>	Standby Current	All output power down	-	50	-	μA
C <sub>IN</sub>	Input Capacitance - All inputs except XIN	SSON, OE, PD# or FS inputs	-	-	7	pF

## AC Electrical Specifications

Parameter	Description	Conditions	Min.	Typ.	Max.	Unit
F <sub>IN</sub> (crystal)	Crystal Frequency		8	–	48	MHz
F <sub>IN</sub> (clock)	Input Clock Frequency (XIN or EXCLKIN)		8	–	166	MHz
F <sub>OUT</sub>	Output Clock Frequency		3	–	166	MHz
DC	Output Duty Cycle All Clocks except Ref Out	Duty Cycle is defined in <a href="#">Figure 2, "Duty Cycle Definition,"</a> on page 8; t <sub>1</sub> /t <sub>2</sub> , 50% of V <sub>DD</sub>	45	50	55	%
DC	Ref Out Duty Cycle	Ref In Min 45%, Max 55%	40		60	%
E <sub>R</sub>	CLK1-9 Rising Edge Rate	V <sub>DD</sub> = All, 20% to 80% V <sub>DD</sub>	0.8	–	–	V/ns
E <sub>F</sub>	CLK1-9 Falling Edge Rate	V <sub>DD</sub> = All, 20% to 80% V <sub>DD</sub>	0.8	–	–	V/ns
T <sub>CCJ1</sub>	Cycle-to-cycle Jitter	Configuration dependent. See <a href="#">Table 2, "Configuration Example for Jitter,"</a> on page 6	–	–	–	ps
T <sub>LTJ</sub>	Long Term Jitter (1000 cycle period jitter)	Configuration dependent. See <a href="#">Table 2, "Configuration Example for Jitter,"</a> on page 6	–	–	–	ns
T <sub>10</sub>	PLL Lock Time		–	1	3	ms

**Table 2. Configuration Example for Jitter**

Reference	Description	Max Jitter (ps) on Output 1(48MHz)	Max Jitter (ps) on Output 2 (27 MHz)	Max Jitter (ps) on Output 3 (166 MHz)	Max Jitter (ps) on Output 4 (74.25 MHz)
<b>Cycle-to-Cycle Jitter</b>					
27MHz	T <sub>CCJ1</sub>	155	255	170	195
48 MHz	T <sub>CCJ1</sub>	135	225	100	125
<b>Long Term Jitter</b>					
27MHz	T <sub>LTJ</sub>	770	580	630	1105
48 MHz	T <sub>LTJ</sub>	535	575	520	795

**Note**

1. Configuration dependent.

**Recommended Crystal Specification for SMD Package**

Parameter	Description	Range 1	Range 2	Range 3	Unit
Fmin	Minimum Frequency	8	14	28	MHz
Fmax	Maximum Frequency	14	28	48	MHz
R1(max)	Maximum Motional Resistance (ESR)	135	50	30	$\Omega$
C0(max)	Maximum Shunt Capacitance	4	4	2	pF
CL(max)	Maximum Parallel Load Capacitance	18	14	12	pF
DL(max)	Maximum Crystal Drive Level	300	300	300	$\mu$ W

**Recommended Crystal Specification for Thru-Hole Package**

Parameter	Description	Range 1	Range 2	Range 3	Unit
Fmin	Minimum Frequency	8	14	24	MHz
Fmax	Maximum Frequency	14	24	32	MHz
R1(max)	Maximum Motional Resistance (ESR)	90	50	30	$\Omega$
C0(max)	Maximum Shunt Capacitance	7	7	7	pF
CL(max)	Maximum Parallel Load Capacitance	18	12	12	pF
DL(max)	Maximum Crystal Drive Level	1000	1000	1000	$\mu$ W

**Test and Measurement Setup**

**Figure 1. Test and Measurement Setup**

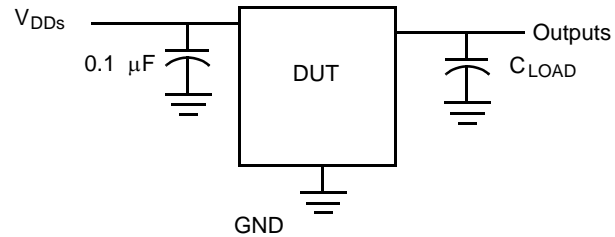

**Voltage and Timing Definitions**

**Figure 2. Duty Cycle Definition**

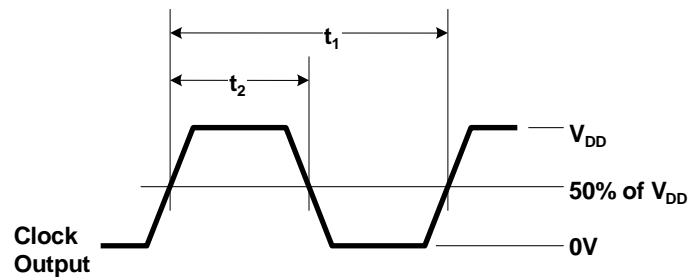

**Figure 3.  $ER = (0.6 \times V_{DD}) / t_3$ ,  $EF = (0.6 \times V_{DD}) / t_4$**

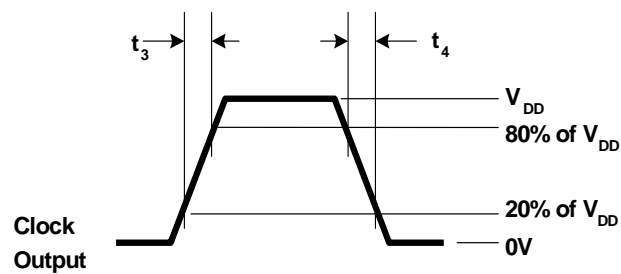



**Ordering Information**

Part Number <sup>[2]</sup>	Type	VDD(V)	Temperature Range
<b>Lead-free</b>			
CY2544Cxxx	24-pin QFN	3.3, 3.0 or 2.5	Commercial, 0°C to 70°C
CY2544CxxxT	24-pin QFN -Tape & Reel	3.3, 3.0 or 2.5	Commercial, 0°C to 70°C
CY2544FC	24-pin QFN	3.3, 3.0 or 2.5	Commercial, 0°C to 70°C
CY2544FCT	24-pin QFN - Tape & Reel	3.3, 3.0 or 2.5	Commercial, 0°C to 70°C
CY2546Cxxx	24-pin QFN	1.8	Commercial, 0°C to 70°C
CY2546CxxxT	24-pin QFN -Tape & Reel	1.8	Commercial, 0°C to 70°C
CY2546FC	24-pin QFN	1.8	Commercial, 0°C to 70°C
CY2546FCT	24-pin QFN -Tape & Reel	1.8	Commercial, 0°C to 70°C
CY2544IxxxT	24-pin QFN -Tape & Reel	3.3, 3.0 or 2.5	Industrial, -40°C to +85°C
CY2544FI	24-pin QFN	3.3, 3.0 or 2.5	Industrial, -40°C to +85°C
CY2544FIT	24-pin QFN - Tape & Reel	3.3, 3.0 or 2.5	Industrial, -40°C to +85°C
CY2546Ixxx	24-pin QFN	1.8	Industrial, -40°C to +85°C
CY2546IxxxT	24-pin QFN -Tape & Reel	1.8	Industrial, -40°C to +85°C
CY2546FI	24-pin QFN	1.8	Industrial, -40°C to +85°C
CY2546FIT	24-pin QFN -Tape & Reel	1.8	Industrial, -40°C to +85°C

**Note**

2. xxx Indicates Factory Programmable are factory programmed configurations. For more details, contact your local Cypress FAE or Cypress Sales Representative. F in the part number indicates field programmable using CyberClocks Online software.

**Package Drawing and Dimensions**

**Figure 4. 24-Lead QFN 4x4 mm (Subcon Punch Type Pkg with 2.49x2.49 EPAD) LF24A**

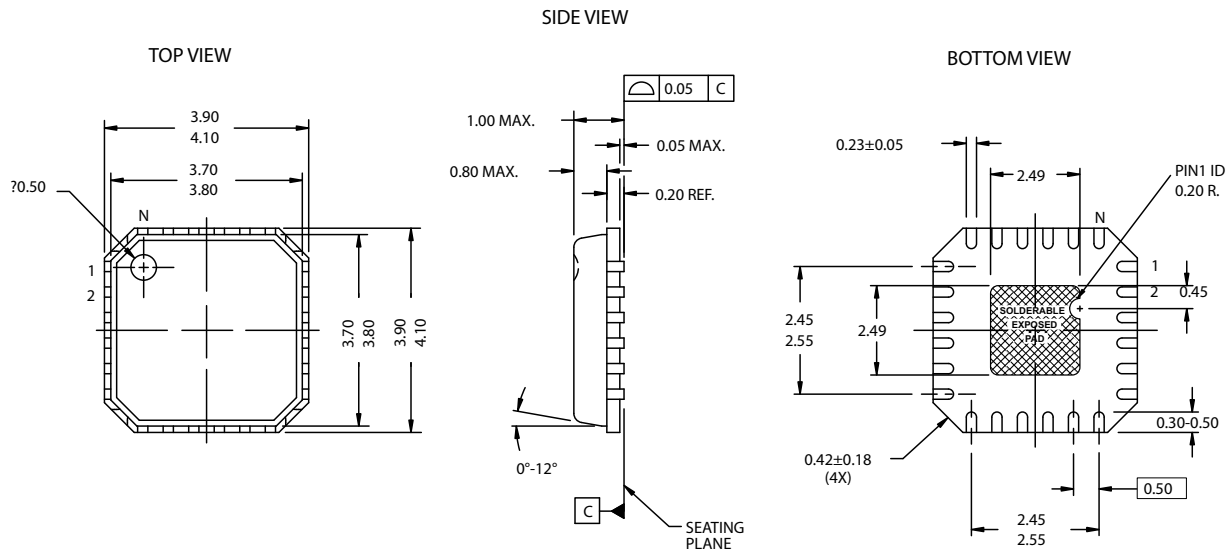

**NOTES:**

1.  HATCH IS SOLDERABLE EXPOSED METAL.
2. REFERENCE JEDEC#: MO-220
3. PACKAGE WEIGHT: 0.042g
4. ALL DIMENSIONS ARE IN MM [MIN/MAX]
5. PACKAGE CODE

51-85203-A

PART #	DESCRIPTION
LF24A	STANDARD
LY24A	LEAD FREE

CyberClocks is a trademark of Cypress Semiconductor Corporation. All products and company names mentioned in this document may be the trademarks of their respective holders.

**Document History Page**

Document Title: CY2544/CY2546 Quad PLL Programmable Clock Generator with Spread Spectrum Document Number: 001-12563				
REV.	ECN NO.	Issue Date	Orig. of Change	Description of Change
**	690257	See ECN	RGL	New Data Sheet
*A	790516	See ECN	RGL	Separated the Pin Configuration drawing into two to show the difference between CY2544 and CY2546 pin outs. Changed the IDD from 22mA maximum to 25mA typical Changed I <sub>ILSR</sub> Internal pull down from 100K to 160K Changed I <sub>IHSR</sub> Internal pull down from 100k to 160K and changed the maximum value from 10μA to 25μA Changed I <sub>ILPDOE</sub> to No Internal pull up and changed the maximum value from 10μA to 1μA Changed I <sub>IHPDOE</sub> to no Internal pull up

## X-ON Electronics

Largest Supplier of Electrical and Electronic Components

*Click to view similar products for [Clock Generators & Support Products](#) category:*

*Click to view products by [Cypress](#) manufacturer:*

Other Similar products are found below :

[5P49V5901B744NLGI](#) [5P49V5929B502NLGI](#) [5P49V5935B520LTGI](#) [CV183-2TPAG](#) [8T49N004A-039NLGI](#) [9FGV0631CKLF](#)  
[9FGV0641AKLFT](#) [9LRS3197AKLF](#) [9VRS4450AKLF](#) [NB3N51132DTR2G](#) [P1P3800AG12CRTWG](#) [8N3Q001EG-0035CDI](#)  
[932SQ426AKLF](#) [950810CGLF](#) [9DBV0531AKILF](#) [9DBV0741AKILF](#) [9FGV0641AKLF](#) [9UMS9633BKLF](#) [9VRS4420DKILF](#)  
[9VRS4420DKLF](#) [CY25404ZXI226](#) [CY25422SXI-004](#) [NB3H5150-01MNTXG](#) [6INT61041NDG](#) [P3MS650100H-4CR](#) [P3P8203AMTTBG](#)  
[PL602-20-K52TC](#) [PL613-51QC](#) [MD82C84A/B](#) [9FGV0641AKILF](#) [ZL30314GKG2](#) [ZL30250LDG1](#) [ZL30142GGG2](#) [9UMS9633BKILFT](#)  
[9FGV0631CKLFT](#) [9FGV0631CKILF](#) [PI6LC48P0101LIE](#) [DS1099U-ST+](#) [MAX24305EXG+](#) [PI6LC48H02-01LIE](#) [82P33814ANLG](#)  
[932SQ426AGLFT](#) [840021AGLF](#) [MAX3674ECM+](#) [5V49EE901-064PGGI](#) [ZL30244LFG7](#) [DS1089LU-23C+](#) [PI6LC48C21LE](#)  
[ZL30106QDG1](#) [ZL30245LFG7](#)