

Quad PLL Programmable Clock Generator with Spread Spectrum

Features

- Four fully integrated phase locked loops (PLLs)
 - External crystal: 8 to 48 MHz for CY2544 and CY2546
 - External reference: 8 to 166 MHz clock
- Input frequency range
 - 2.5V, 3.0V, and 3.3V for CY2548
 - 1.8V for CY2544 and CY2546
- Reference clock input voltage range
 - 2.5V, 3.0V, and 3.3V for CY2548
 - 1.8V for CY2544 and CY2546
- Wide operating output frequency range
 - 3 to 166 MHz
- Programmable spread spectrum with center and down spread option and Lexmark and Linear modulation profiles
- VDD supply voltage options:
 - 2.5V, 3.0V, and 3.3V for CY2544 and CY2548
 - 1.8V for CY2546
- Selectable output clock voltages:
 - 2.5V, 3.0V, and 3.3V for CY2544 and CY2548
 - 1.8V for CY2546
- Frequency select feature with option to select eight different frequencies over nine clock outputs
- Power down, output enable, and SS ON/OFF controls
- Low jitter, high accuracy outputs
- Ability to synthesize nonstandard frequencies with Fractional-N capability

- Up to nine clock outputs with programmable drive strength
- Glitch free outputs while frequency switching
- 24-pin QFN package
- Commercial and Industrial temperature ranges

Benefits

- Multiple high performance PLLs allow synthesis of unrelated frequencies
- Nonvolatile programming for personalization of PLL frequencies, spread spectrum characteristics, drive strength, crystal load capacitance, and output frequencies
- Application specific programmable EMI reduction using spread spectrum for clocks
- Programmable PLLs for system frequency margin tests
- Meets critical timing requirements in complex system designs
- Suitability for PC, consumer, portable, and networking applications
- Capable of Zero PPM frequency synthesis error
- Uninterrupted system operation during clock frequency switch
- Application compatibility in standard and low power systems

Logic Block Diagram

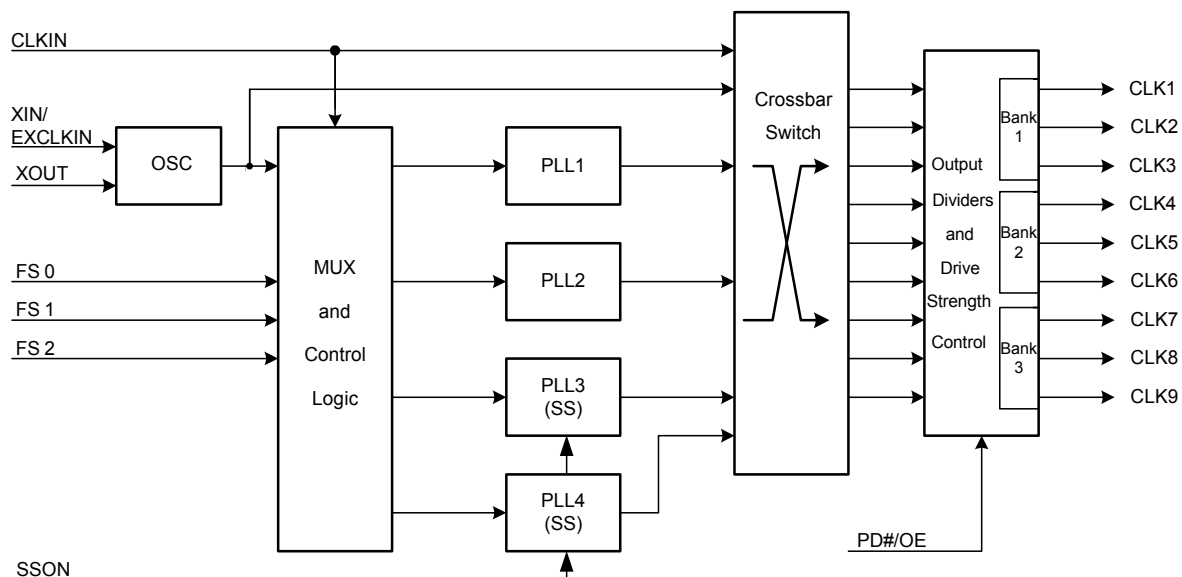

Contents

General Description	5	Test and Measurement Setup	10
Four Configurable PLLs	5	Voltage and Timing Definitions	10
Input Reference Clocks	5	Recommended Crystal Specification for	
Multiple Power Supplies	5	Thru-Hole Package	10
Output Bank Settings	5	Ordering Information	11
Output Source Selection	5	Possible Configurations	11
Spread Spectrum Control	5	Ordering Code Definition	12
Frequency Select	6	Package Drawing and Dimensions	13
Glitch-Free Frequency Switch	6	Acronyms	14
PD#/OE Mode	6	Document Conventions	14
Output Drive Strength	6	Units of Measure	14
Generic Configuration and Custom Frequency	6	Document History Page	15
Absolute Maximum Conditions	7	Sales, Solutions, and Legal Information	16
Recommended Operating Conditions	7	Worldwide Sales and Design Support	16
DC Electrical Specifications	8	Products	16
AC Electrical Specifications	9	PSoC Solutions	16
Recommended Crystal Specification for SMD Package	9		

Table 1. Device Selection Guide

Device	Crystal Input	EXCKLKIN Input	CLKIN Input	VDD	VDD_CLK_BX
CY2544	Yes	1.8 V LVCMOS	2.5 V, 3.0 V, 3.3 V LVCMOS	2.5 V, 3.0 V, 3.3 V	2.5 V, 3.0 V, 3.3 V
CY2546	Yes	1.8 V LVCMOS	1.8 V LVCMOS	1.8 V	1.8 V
CY2548	No	2.5 V, 3.0 V, 3.3 V LVCMOS	2.5 V, 3.0 V, 3.3 V LVCMOS	2.5 V, 3.0 V, 3.3 V	2.5 V, 3.0 V, 3.3 V

Figure 1. Pin Diagram – CY2544/CY2548 24 LD QFN

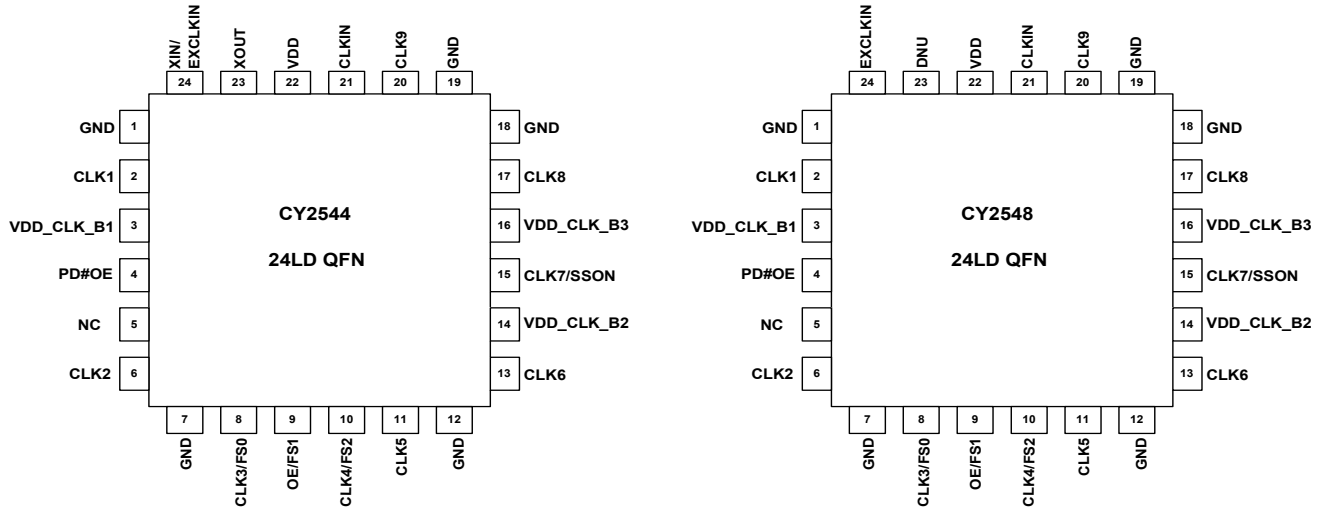

Table 2. Pin Definition – CY2544/CY2548 (VDD = 2.5 V, 3.0 V or 3.3 V Supply)

Pin Number	Name	IO	Description
1	GND	Power	Power supply ground
2	CLK1	Output	Programmable clock output. Output voltage depends on VDD_CLK_B1 voltage
3	VDD_CLK_B1	Power	Power supply for bank1, (CLK1, CLK2, CLK3) Outputs: 2.5 V/3.0 V/3.3 V
4	PD#/OE	Input	Multifunction programmable pin. Output enable or power-down mode
5	NC	NC	No Connect
6	CLK2	Output	Programmable Clock Output. Output voltage depends on VDD_CLK_B1 voltage
7	GND	Power	Power supply ground
8	CLK3/FS0	Output/input	Multifunction programmable pin. Programmable clock output clock or frequency select pin. Output voltage of CLK3 depends on VDD_CLK_B1 voltage
9	OE/FS1	Input	Multifunction programmable pin. Output enable or frequency select pin
10	CLK4/FS2	Output/input	Multifunction programmable pin. Programmable clock output or frequency select input pin. Output voltage of CLK4 depends on VDD_CLK_B2 voltage
11	CLK5	Output	Programmable clock output. Output voltage depends on VDD_CLK_B2 voltage
12	GND	Power	Power supply ground
13	CLK6	Output	Programmable clock output. Output voltage depends on VDD_CLK_B2 voltage
14	VDD_CLK_B2	Power	Power supply for bank2, (CLK4, CLK5, CLK6) Outputs. 2.5 V/3.0 V/3.3 V
15	CLK7/SSON	Output/input	Multifunction programmable pin. Programmable clock output or spread spectrum ON/OFF control input pin. Output voltage of CLK7 depends on Bank3 voltage
16	VDD_CLK_B3	Power	Power supply for bank3, (CLK7, CLK8, CLK9) Outputs. 2.5 V/3.0 V/3.3 V

Table 2. Pin Definition – CY2544/CY2548 (VDD = 2.5 V, 3.0 V or 3.3 V Supply) (continued)

Pin Number	Name	IO	Description
17	CLK8	Output	Programmable output clock. Output voltage depends on Bank3 voltage
18	GND	Power	Power supply ground
19	GND	Power	Power supply ground
20	CLK9	Output	Programmable clock output. Output voltage depends on VDD_CLK_B3 voltage
21	CLKIN	Input	2.5 V/3.0 V/3.3 V reference clock input. The signal level of CLKIN input must track VDD power supply on pin 22.
22	VDD	Power	Power supply. 2.5 V/3.0 V/3.3 V
23	XOUT	Output	Crystal output for CY2544
	DNU	Output	Do not use this pin for CY2548
24	XIN/EXCLKIN	Input	Crystal input or 1.8 V external clock input for CY2544
	EXCLKIN	Input	2.5 V/3.0 V/3.3 V external clock input for CY2548

Figure 2. Pin Diagram – CY2546 24 LD QFN

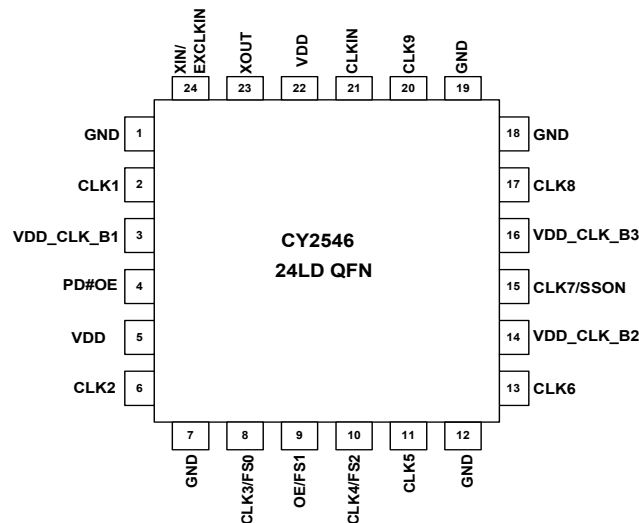

Table 3. Pin Definition – CY2546 (VDD = 1.8 V Supply)

Pin Number	Name	IO	Description
1	GND	Power	Power supply ground
2	CLK1	Output	Programmable clock output. Output voltage depends on VDD_CLK_B1 voltage
3	VDD_CLK_B1	Power	Power supply for bank1, (CLK1, CLK2, CLK3) Outputs. 1.8V
4	PD#/OE	Input	Multifunction programmable pin. Output enable or power down mode
5	VDD	Power	Power supply. 1.8 V
6	CLK2	Output	Programmable clock output. Output voltage depends on VDD_CLK_B1 voltage
7	GND	Power	Power supply ground
8	CLK3/FS0	Output/Input	Multifunction programmable pin. Programmable clock output or frequency select input pin. Output voltage of CLK3 depends on VDD_CLK_B1 voltage
9	OE/FS1	Input	Multifunction programmable pin. Output enable or frequency select pin
10	CLK4/FS2	Output/Input	Multifunction programmable pin. Programmable clock output or frequency select input pin. Output voltage of CLK4 depends on VDD_CLK_B2 voltage
11	CLK5	Output	Programmable clock output. Output voltage depends on VDD_CLK_B2 voltage

Table 3. Pin Definition – CY2546 (VDD = 1.8 V Supply) (continued)

Pin Number	Name	IO	Description
12	GND	Power	Power supply ground
13	CLK6	Output	Programmable clock output. Output voltage depends on VDD_CLK_B2 voltage
14	VDD_CLK_B2	Power	Power supply for bank2, (CLK4, CLK5, CLK6) Outputs. 1.8 V
15	CLK7/SSON	Output/input	Multifunction programmable pin. Programmable clock output or spread spectrum ON/OFF control input pin. Output voltage of CLK7 depends on VDD_CLK_B3 voltage
16	VDD_CLK_B3	Power	Power supply for bank3, (CLK7, CLK8, CLK9) Outputs. 1.8 V
17	CLK8	Output	Programmable clock output. Output voltage depends on VDD_CLK_B3 voltage
18	GND	Power	Power supply ground
19	GND	Power	Power supply ground
20	CLK9	Output	Programmable clock output. Output voltage depends on VDD_CLK_B3 voltage
21	CLKIN	Input	External 1.8 V low voltage reference clock input
22	VDD	Power	Power supply. 1.8 V
23	XOUT	Output	Crystal output
24	XIN/EXCLKIN	Input	Crystal input or 1.8 V external clock input

General Description

Four Configurable PLLs

The CY2544, CY2548 and CY2546 have four programmable PLLs that can be used to generate output frequencies ranging from 3 to 166 MHz. The advantage of having four PLLs is that a single device generates up to four independent frequencies from a single crystal.

Input Reference Clocks

The input to the CY2544, CY2548 and CY2546 can be either a crystal or a clock signal. The input frequency range for crystal (XIN) is 8 MHz to 48 MHz and that for external reference clock (EXCLKIN) is 8 MHz to 166 MHz. The voltage range for the reference clock input of CY2548 is 2.5 V/3.0 V/3.3 V while that for CY2544 and CY2546 is 1.8 V. This gives user an option for this device to be compatible for different input clock voltage levels in the system.

There is provision for a secondary reference clock input, CLKIN with applied frequency range of 8 MHz to 166 MHz. When CLKIN signal at pin 21 is used as a reference input to the PLL, a valid signal at EXCLKIN (as specified in the AC and DC Electrical Specification table) must be present for the devices to operate properly.

Multiple Power Supplies

These devices are designed to operate at internal supply voltage of 1.8 V. In the case of the high voltage part (CY2544/CY2548), an internal regulator is used to generate 1.8 V from the 2.5 V/3.0 V/3.3 V VDD supply voltage at pin 22. For the low voltage part (CY2546), this internal regulator is bypassed and 1.8 V at VDD pin 22 is directly used.

Output Bank Settings

There are nine clock outputs grouped in three output driver banks. The Bank 1, Bank 2, and Bank 3 correspond to (CLK1, CLK2, CLK3), (CLK4, CLK5, CLK6), and (CLK7, CLK8, CLK9) respectively. Separate power supplies are used for each of these banks and they can be any of 2.5 V, 3.0 V, or 3.3 V for CY2544/CY2548 and 1.8 V for CY2546 giving user multiple choice of output clock voltage levels.

Output Source Selection

These devices have programmable input sources for each of its nine clock outputs (CLK1–9). There are six available clock sources for these outputs. These clock sources are: XIN/EXCLKIN, CLKIN, PLL1, PLL2, PLL3, or PLL4. Output clock source selection is done using four out of six crossbar switch. Thus, any one of these six available clock sources can be arbitrarily selected for the clock outputs. This gives user a flexibility to have up to four independent clock outputs.

Spread Spectrum Control

Two of the four PLLs (PLL3 and PLL4) have spread spectrum capability for EMI reduction in the system. The device uses a Cypress proprietary PLL and spread spectrum clock (SSC) technology to synthesize and modulate the frequency of the PLL. The spread spectrum feature can be turned on or off using a multifunction control pin (CLK7/SSON). It can be programmed to either center spread range from $\pm 0.125\%$ to $\pm 2.50\%$ or down spread range from -0.25% to -5.0% with Lexmark or Linear profile.

Frequency Select

There are three multifunction frequency select pins (FS0, FS1 and FS2) that provide an option to select eight different sets of frequencies among each of the four PLLs. Each output has programmable output divider options.

Glitch-Free Frequency Switch

When the frequency select pin (FS) is used to switch frequency, the outputs are glitch-free provided frequency is switched using output dividers. This feature enables uninterrupted system operation while clock frequency is being switched.

PD#/OE Mode

PD#/OE (Pin 4) can be programmed to operate as either power down (PD#) or output enable (OE) mode. PD# is a low-true input. If activated it shuts off the entire chip, resulting in minimum power consumption for the device. Setting this signal high brings the device in the operational mode with default register settings.

When this pin is programmed as Output Enable (OE), clock outputs can be enabled or disabled using OE (pin 4). Individual clock outputs can be programmed to be sensitive to this OE pin.

Output Drive Strength

The DC drive strength of the individual clock output can be programmed for different values. Table 4 shows the typical rise and fall times for different drive strength settings.

Table 4. Output Drive Strength

Output Drive Strength	Rise/Fall Time (ns) (Typical Value)
Low	6.8

Table 4. Output Drive Strength

Output Drive Strength	Rise/Fall Time (ns) (Typical Value)
Mid Low	3.4
Mid High	2.0
High	1.0

Generic Configuration and Custom Frequency

There is a generic set of output frequencies available from the factory that can be used for the device evaluation purposes. The devices, CY2544, CY2548 and CY2546 can be custom programmed to any desired frequencies and listed features. For customer specific programming, please contact local Cypress Field application engineer (FAE) or sales representative.

Absolute Maximum Conditions

Parameter	Description	Condition	Min	Max	Unit
V _{DD}	Supply voltage for CY2544/CY2548		-0.5	4.5	V
V _{DD}	Supply voltage for CY2546		-0.5	2.6	V
V _{DD_CLK_BX}	Output bank supply voltage		-0.5	4.5	V
V _{IN}	Input voltage for CY2544/CY2548	Relative to V _{SS}	-0.5	V _{DD} +0.5	V
V _{IN}	Input voltage for CY2546	Relative to V _{SS}	-0.5	2.2	V
T _S	Temperature, storage	Non functional	-65	+150	°C
ESD _{HBM}	ESD protection (Human body model)	JEDEC EIA/JESD22-A114-E	2000	-	Volts
UL-94	Flammability rating	V-0 at 1/8 in.	-	10	ppm
MSL	Moisture sensitivity level		3		

Recommended Operating Conditions

Parameter	Description	Min	Typ	Max	Unit
V _{DD}	VDD Operating voltage for CY2544/CY2548	2.25	-	3.60	V
V _{DD}	VDD Operating voltage for CY2546	1.65	1.8	1.95	V
V _{DD_CLK_BX}	Output driver voltage for Bank 1, 2 and 3	1.65	-	3.60	V
T _{AC}	Commercial ambient temperature	0	-	+70	°C
T _{AI}	Industrial ambient temperature	-40	--	+85	°C
C _{LOAD}	Maximum load capacitance	-	-	15	pF
t _{PU}	Power up time for all V _{DD} to reach minimum specified voltage (power ramps must be monotonic)	0.05	-	500	ms

DC Electrical Specifications

Parameter	Description	Conditions	Min	Typ	Max	Unit
V _{OL}	Output low voltage	I _{OL} = 2 mA, drive strength = [00]	–	–	0.4	V
		I _{OL} = 3 mA, drive strength = [01]				
		I _{OL} = 7 mA, drive strength = [10]				
		I _{OL} = 12 mA, drive strength = [11]				
V _{OH}	Output high voltage	I _{OH} = –2 mA, drive strength = [00]	V _{DD_CLK_BX} –0.4	–	–	V
		I _{OH} = –3 mA, drive strength = [01]				
		I _{OH} = –7 mA, drive strength = [10]				
		I _{OH} = –12 mA, drive strength = [11]				
V _{IL1}	Input low voltage of PD#/OE, FS0, FS1, FS2 and SSON	–	–	–	0.2 × V _{DD}	V
V _{IL2}	Input low voltage of CLKIN for CY2544/CY2548	–	–	–	0.1 × V _{DD}	V
V _{IL3}	Input low voltage of EXCLKIN for CY2544	–	–	–	0.15	V
V _{IL4}	Input low voltage of EXCLKIN for CY2548	–	–	–	0.1 × V _{DD}	V
V _{IL5}	Input low voltage of CLKIN, EXCLKIN for CY2546	–	–	–	0.1 × V _{DD}	V
V _{IH1}	Input high voltage of PD#/OE, FS0, FS1, FS2 and SSON	–	0.8 × V _{DD}	–	–	V
V _{IH2}	Input high voltage of CLKIN for CY2544/CY2548	–	0.9 × V _{DD}	–	–	V
V _{IH3}	Input high voltage of EXCLKIN for CY2544	–	1.6	–	2.2	V
V _{IH4}	Input high voltage of EXCLKIN for CY2548	–	0.9 × V _{DD}	–	–	V
V _{IH5}	Input high voltage of CLKIN, EXCLKIN for CY2546	–	0.9 × V _{DD}	–	–	V
I _{IL1}	Input low current of PD#/OE and FS1	V _{IL} = 0V	–	–	10	μA
I _{IH1}	Input high current of PD#/OE and FS1	V _{IH} = V _{DD}	–	–	10	μA
I _{IL2}	Input low current of SSON, FS0, and FS2	V _{IL} = 0V (Internal pull dn = 160k typ)	–	–	10	μA
I _{IH2}	Input high current of SSON, FS0, and FS2	V _{IH} = V _{DD} (Internal pull dn = 160k typ)	14	–	36	μA
R _{DN}	Pull down resistor of SSON, FS0, FS2 and clocks (CLK1-CLK9) in off-state	Clock outputs in off-state by setting PD# = Low	100	160	250	kΩ
I _{DD} ^[1,2]	Supply current for CY2546	PD# = High, No load	–	20	–	mA
	Supply current for CY2544/CY2548	PD# = High, No load	–	22	–	mA
I _{DDS} ^[1]	Standby current	PD# = Low	–	3	–	μA
C _{IN} ^[1]	Input capacitance	SSON, CLKIN, PD#/OE, FS0, FS1, and FS2 pins	–	–	7	pF

Notes

- Guaranteed by design but not 100% tested.
- Configuration dependent.

AC Electrical Specifications

Parameter	Description	Conditions	Min	Typ	Max	Unit
F _{IN} (crystal)	Crystal frequency, XIN	–	8	–	48	MHz
F _{IN} (clock)	Input clock frequency (CLKIN or EXCLKIN)	–	8	–	166	MHz
F _{CLK}	Output clock frequency	–	3	–	166	MHz
DC1	Output duty cycle, All clocks except ref out	Duty cycle is defined in Figure 4; t ₁ /t ₂ , measured at 50% of V _{DD-CLK_BX}	45	50	55	%
DC2	Ref Out clock duty cycle	Ref In Min 45%, Max 55%	40	–	60	%
T _{RF1} ^[3]	Output rise/fall Time	Measured from 20% to 80% of V _{DD-CLK_BX} , as shown in Figure 5, C _{LOAD} = 15 pF, Drive strength [00]	–	6.8	–	ns
T _{RF2} ^[3]	Output rise/fall time	Measured from 20% to 80% of V _{DD-CLK_BX} , as shown in Figure 5, C _{LOAD} = 15 pF, Drive strength [01]	–	3.4	–	ns
T _{RF3} ^[3]	Output rise/fall time	Measured from 20% to 80% of V _{DD-CLK_BX} , as shown in Figure 5, C _{LOAD} = 15 pF, Drive strength [10]	–	2.0	–	ns
T _{RF4} ^[3]	Output rise/fall time	Measured from 20% to 80% of V _{DD-CLK_BX} , as shown in Figure 5, C _{LOAD} = 15 pF, Drive strength [11]	–	1.0	–	ns
T _{CCJ} ^[3,4]	Cycle-to-cycle Jitter (peak)	Configuration dependent. See Table 5	–	150	–	ps
T _{LOCK} ^[3]	PLL lock time	Measured from 90% of the applied power supply level	–	1	3	ms

Table 5. Configuration Example for C-C Jitter

Ref. Freq. (MHz)	CLK1 Output		CLK2 Output		CLK3 Output		CLK4 Output		CLK5 Output	
	Freq. (MHz)	C-C Jitter Typ (ps)	Freq. (MHz)	C-C Jitter Typ (ps)	Freq. (MHz)	C-C Jitter Typ (ps)	Freq. (MHz)	C-C Jitter Typ (ps)	Freq. (MHz)	C-C Jitter Typ (ps)
14.3181	8.0	134	166	103	48	92	74.25	81	Not Used	
19.2	74.25	99	166	94	8	91	27	110	48	75
27	48	67	27	109	166	103	74.25	97	Not Used	
48	48	93	27	123	166	137	166	138	8	103

Recommended Crystal Specification for SMD Package

Parameter	Description	Range 1	Range 2	Range 3	Unit
F _{IN}	Crystal frequency	8 – 14	14 – 28	28 – 48	MHz
R1	Maximum motional resistance (ESR)	135	50	30	Ω
CL	Parallel load capacitance (see Note 3 below)	8 – 18	8 – 14	8 – 12	pF
DL(max)	Maximum crystal drive level	300	300	300	μW

Notes

3. Guaranteed by design but not 100% tested
4. Configuration dependent

Recommended Crystal Specification for Thru-Hole Package

Parameter ^[5]	Description	Range 1	Range 2	Range 3	Unit
F_{IN}	Crystal frequency	8 – 14	14 – 24	24 – 32	MHz
R1	Maximum motional resistance (ESR)	90	50	30	Ω
CL	Parallel load capacitance (see Note 3 below)	8 – 18	8 – 12	8 – 12	pF
DL(max)	Maximum crystal drive level	1000	1000	1000	μ W

Test and Measurement Setup

Figure 3. Test and Measurement Setup

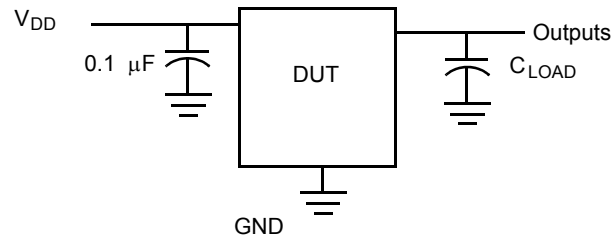

Voltage and Timing Definitions

Figure 4. Duty Cycle Definition

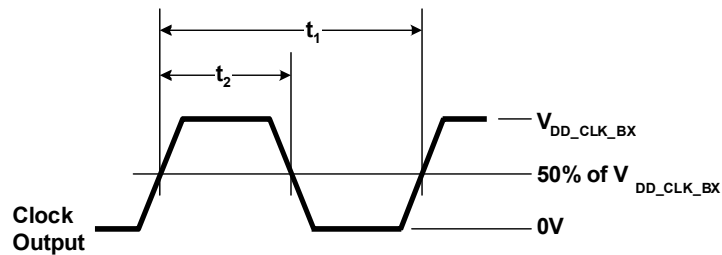
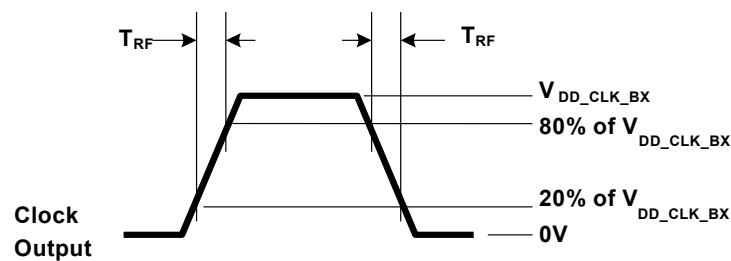

Figure 5. Rise Time = T_{RF} Fall Time = T_{RF}



Note

5. CY2544, CY2548 and CY2546 have internal crystal load capacitance (CL) adjustment feature.

Ordering Information

Part Number	Type ^[6]	Package	Supply Voltage	Operating Range
Pb-free				
CY2544C	Field Programmable	24-pin QFN	2.5 V, 3.0 V or 3.3 V	Commercial, 0 °C to 70 °C
CY2544CT	Field Programmable	24-pin QFN -tape and reel	2.5 V, 3.0V or 3.3 V	Commercial, 0 °C to 70 °C
CY2548C	Field Programmable	24-pin QFN	2.5 V, 3.0V or 3.3 V	Commercial, 0 °C to 70 °C
CY2548CT	Field Programmable	24-pin QFN -tape and reel	2.5 V, 3.0V or 3.3 V	Commercial, 0 °C to 70 °C
CY2546C	Field Programmable	24-pin QFN	1.8 V	Commercial, 0 °C to 70 °C
CY2546CT	Field Programmable	24-pin QFN -tape and reel	1.8 V	Commercial, 0 °C to 70 °C
CY2544I	Field Programmable	24-pin QFN	2.5 V, 3.0 V or 3.3 V	Industrial, -40 °C to +85 °C
CY2544IT	Field Programmable	24-pin QFN -tape and reel	2.5 V, 3.0 V or 3.3 V	Industrial, -40 °C to +85 °C
CY2548I	Field Programmable	24-pin QFN	2.5 V, 3.0 V or 3.3 V	Industrial, -40 °C to +85 °C
CY2548IT	Field Programmable	24-pin QFN -tape and reel	2.5 V, 3.0 V or 3.3 V	Industrial, -40 °C to +85 °C
CY2546I	Field Programmable	24-pin QFN	1.8 V	Industrial, -40 °C to +85 °C
CY2546IT	Field Programmable	24-pin QFN -tape and reel	1.8 V	Industrial, -40 °C to +85 °C
Programmer				
CY3675-CLKMAKER1	Programming kit			
CY3675-QFN24A	Socket adapter board, for programming CY2544 and CY2548 ^[7]			

Some product offerings are factory programmed customer specific devices with customized part numbers. The Possible Configurations table shows the available device types, but not complete part numbers. Contact your local Cypress FAE of Sales Representative for more information.

Possible Configurations

Part Number ^[8]	Type ^[6]	Package	Supply Voltage	Operating Range
Pb-free				
CY2544Cxxx	Factory Programmed	24-pin QFN	2.5 V, 3.0 V or 3.3 V	Commercial, 0 °C to 70 °C
CY2544CxxxT	Factory Programmed	24-pin QFN -tape and reel	2.5 V, 3.0 V or 3.3 V	Commercial, 0 °C to 70 °C
CY2548Cxxx	Factory Programmed	24-pin QFN	2.5 V, 3.0 V or 3.3 V	Commercial, 0 °C to 70 °C
CY2548CxxxT	Factory Programmed	24-pin QFN -tape and reel	2.5 V, 3.0 V or 3.3 V	Commercial, 0 °C to 70 °C
CY2546Cxxx	Factory Programmed	24-pin QFN	1.8 V	Commercial, 0 °C to 70 °C
CY2546CxxxT	Factory Programmed	24-pin QFN -tape and reel	1.8 V	Commercial, 0 °C to 70 °C
CY2544Ixxx	Factory Programmed	24-pin QFN	2.5 V, 3.0 V or 3.3 V	Industrial, -40 °C to +85 °C
CY2544IxxxT	Factory Programmed	24-pin QFN -tape and reel	2.5 V, 3.0 V or 3.3 V	Industrial, -40 °C to +85 °C
CY2548Ixxx	Factory Programmed	24-pin QFN	2.5 V, 3.0 V or 3.3 V	Industrial, -40 °C to +85 °C
CY2548IxxxT	Factory Programmed	24-pin QFN -tape and reel	2.5 V, 3.0 V or 3.3 V	Industrial, -40 °C to +85 °C
CY2546Ixxx	Factory Programmed	24-pin QFN	1.8 V	Industrial, -40 °C to +85 °C
CY2546IxxxT	Factory Programmed	24-pin QFN -tape and reel	1.8 V	Industrial, -40 °C to +85 °C

Notes

- Field Programmable devices are shipped unprogrammed, and must be programmed before being installed on a board. Factory Programmed devices are shipped fully configured and ready to install on a board.
- The CY3675-QFN24A cannot be used to program the CY2546.
- "xxx" is a variable that denotes a specific device configuration. For more details, contact your local Cypress FAE or Cypress Sales Representative.

Ordering Code Definition

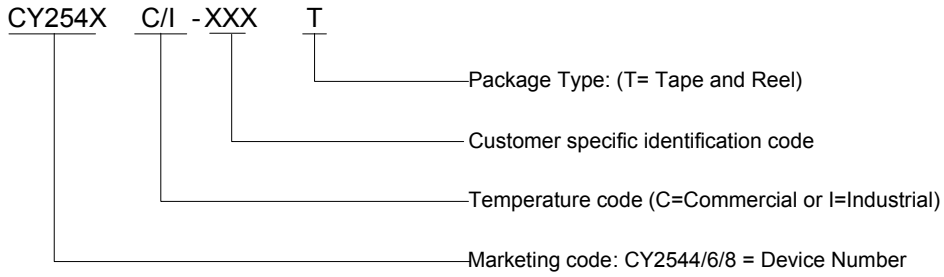

Acronyms

Acronym	Description
DL	drive level
DNU	do not use
DUT	device under test
EMI	electromagnetic interference
ESD	electrostatic discharge
FAE	field application engineer
FS	frequency select
JEDEC EIA	joint electron devices engineering council electronic industries alliance
LVC MOS	low voltage complementary metal oxide semiconductor
OE	output enable
OSC	oscillator
PD	power down
PLL	phase locked loop
PPM	parts per million
SS	spread spectrum
SSC	spread spectrum clock
SSON	spread spectrum on

Document Conventions

Units of Measure

Symbol	Unit of Measure
°C	degrees Celsius
fF	femtofarads
mA	milliampere
MHz	megahertz
μs	microseconds
ms	millisecond
μW	microwatts
ns	nanoseconds
pF	picofarads
ppm	parts per million
ps	picoseconds
V	volts
Ω	ohms
W	watts

Document History Page

Document Title: CY2544/CY2548 CY2546 Quad PLL Programmable Clock Generator with Spread Spectrum				
Document Number: 001-12563				
Revision	ECN	Orig. of Change	Submission Date	Description of Change
**	690257	RGL	See ECN	New Datasheet
*A	790516	RGL	See ECN	Separated the Pin Configuration drawing into two to show the difference between CY2544 and CY2546 pinouts. Changed the IDD from 22 mA maximum to 25 mA typical Changed I _{I_{LSR}} Internal pull down from 100K to 160K Changed I _{I_{HSR}} Internal pull down from 100K to 160K and changed the maximum value from 10 μA to 25 μA Changed I _{I_{LPDOE}} to No Internal pull up and changed the maximum value from 10 μA to 1 μA Changed I _{I_{HPDOE}} to no Internal pull up
*B	1508943	RGL/AESA	See ECN	Changed the I _{I_{LSR}} maximum value to 10 uA Changed the I _{I_{LPDOE}} and I _{I_{HPDOE}} values to a minimum of 1 μA to a maximum of 10μA Removed Preliminary from Title page Changed the I _{I_{HPD}} from 1 uA to 10 uA Changed the I _{I_{LSR}} from 1 uA to 10 uA Added new I _{I_{DDS}} value = 3uA Added new C-C Jitter typical values, Deleted Long term Jitter values Deleted generic part numbers from Ordering Information Added new device and specification for high ref input voltage part, CY2548 Changed I2C Tsu specification from 100ns to 250 ns Changed ESD spec from MIL-STD to JEDEC Combined VDD operating condition spec for CY2545 to a single VDD spec In DC spec.: FS1 pin has no pull down resistor Added device selection table 1 Removed C0 from crystal spec
*C	2748211	TSAI	08/10/09	Posting to external web.
*D	2764011	CXQ	09/15/09	Fixed typo in Ordering Information table – changed CY2548Cxxx and CY2548CxxxT to CY2548lxxx and CY2548lxxxT for industrial temp parts.
*E	2899758	KVM	03/26/10	Updated Ordering information table. Updated package diagram Updated copyright section.
*F	2969587	KVM	07/09/2010	Minor change: Matched spec title on the first page to document history page. Added "WITH SPREAD SPECTRUM" in first page title.
*G	3115710	BASH	12/21/2010	Added Ordering Code Definition , Acronyms and Units of Measure table.

Sales, Solutions, and Legal Information

Worldwide Sales and Design Support

Cypress maintains a worldwide network of offices, solution centers, manufacturer's representatives, and distributors. To find the office closest to you, visit us at [Cypress Locations](#).

Products

Automotive	cypress.com/go/automotive
Clocks & Buffers	cypress.com/go/clocks
Interface	cypress.com/go/interface
Lighting & Power Control	cypress.com/go/powerpsoc cypress.com/go/plc
Memory	cypress.com/go/memory
Optical & Image Sensing	cypress.com/go/image
PSoC	cypress.com/go/psoc
Touch Sensing	cypress.com/go/touch
USB Controllers	cypress.com/go/USB
Wireless/RF	cypress.com/go/wireless

PSoC Solutions

psoc.cypress.com/solutions
PSoC 1 | PSoC 3 | PSoC 5

© Cypress Semiconductor Corporation, 2007-2010. The information contained herein is subject to change without notice. Cypress Semiconductor Corporation assumes no responsibility for the use of any circuitry other than circuitry embodied in a Cypress product. Nor does it convey or imply any license under patent or other rights. Cypress products are not warranted nor intended to be used for medical, life support, life saving, critical control or safety applications, unless pursuant to an express written agreement with Cypress. Furthermore, Cypress does not authorize its products for use as critical components in life-support systems where a malfunction or failure may reasonably be expected to result in significant injury to the user. The inclusion of Cypress products in life-support systems application implies that the manufacturer assumes all risk of such use and in doing so indemnifies Cypress against all charges.

Any Source Code (software and/or firmware) is owned by Cypress Semiconductor Corporation (Cypress) and is protected by and subject to worldwide patent protection (United States and foreign), United States copyright laws and international treaty provisions. Cypress hereby grants to licensee a personal, non-exclusive, non-transferable license to copy, use, modify, create derivative works of, and compile the Cypress Source Code and derivative works for the sole purpose of creating custom software and or firmware in support of licensee product to be used only in conjunction with a Cypress integrated circuit as specified in the applicable agreement. Any reproduction, modification, translation, compilation, or representation of this Source Code except as specified above is prohibited without the express written permission of Cypress.

Disclaimer: CYPRESS MAKES NO WARRANTY OF ANY KIND, EXPRESS OR IMPLIED, WITH REGARD TO THIS MATERIAL, INCLUDING, BUT NOT LIMITED TO, THE IMPLIED WARRANTIES OF MERCHANTABILITY AND FITNESS FOR A PARTICULAR PURPOSE. Cypress reserves the right to make changes without further notice to the materials described herein. Cypress does not assume any liability arising out of the application or use of any product or circuit described herein. Cypress does not authorize its products for use as critical components in life-support systems where a malfunction or failure may reasonably be expected to result in significant injury to the user. The inclusion of Cypress' product in a life-support systems application implies that the manufacturer assumes all risk of such use and in doing so indemnifies Cypress against all charges.

Use may be limited by and subject to the applicable Cypress software license agreement.

X-ON Electronics

Largest Supplier of Electrical and Electronic Components

Click to view similar products for [Phase Locked Loops - PLL category](#):

Click to view products by [Cypress manufacturer](#):

Other Similar products are found below :

[ADF4152HVBCPZ-RL7](#) [HMC440QS16GTR](#) [LC72135MA-Q-AE](#) [SL28EB725ALI](#) [HMC699LP5ETR](#) [HMC700LP4TR](#) [LC7185-8750-E](#)
[MB15E07SLPFV1-G-BND-6E1](#) [XRT8001ID-F](#) [ATA8404C-6DQY-66](#) [PI6C2409-1HWE](#) [ATA8405C-6DQY-66](#) [MAX2870ETJ+T](#)
[PI6C2409-1HWEX](#) [CYW170-01SXC](#) [HMC764LP6CETR](#) [HMC767LP6CETR](#) [HMC820LP6CETR](#) [HMC828LP6CETR](#) [HMC834LP6GETR](#)
[ispPAC-CLK5410D-01SN64C](#) [SI4113-D-GM](#) [82V3002APVG](#) [PI6C2405A-1WE](#) [CY22050KFI](#) [CY25200KFZXC](#) [CY29973AXI](#)
[CY2XP22ZXI](#) [W232ZXC-10](#) [CDCE937QPWRQ1](#) [CY2077FZXI](#) [CY2546FC](#) [CY2XF23FLXIT](#) [CYISM560BSXC](#) [LMX2430TMX/NOPB](#)
[HMC837LP6CETR](#) [HMC831LP6CETR](#) [ATA8404C-6DQY-66](#) [ADF4155BCPZ-RL7](#) [MB15E07SRPFT-G-BNDE1](#) [NB3N5573DTG](#)
[MAX2660EUT+T](#) [SI4123-D-GT](#) [SI4112-D-GM](#) [NB4N441MNR2G](#) [ADF4116BRUZ-REEL7](#) [ADF4153ABCPZ](#) [MAX2682EUT+T](#) [Si5376B-](#)
[A-GL](#) [SI5347A-A-GM](#)