

2.5 V or 3.3 V, 200-MHz, 9-Output Clock Driver

Features

- Output frequency range: 25 MHz to 200 MHz
- Input frequency range: 6.25 MHz to 31.25 MHz
- 2.5 V or 3.3 V operation
- Split 2.5 V/3.3 V outputs
- $\pm 2.5\%$ max Output duty cycle variation
- Nine Clock outputs: Drive up to 18 clock lines
- Two reference clock inputs: Xtal or LVCMOS
- 150-ps max output-output skew
- Phase-locked loop (PLL) bypass mode
- Spread Aware™
- Output enable/disable
- Pin-compatible with MPC9350
- Industrial temperature range: $-40\text{ }^{\circ}\text{C}$ to $+85\text{ }^{\circ}\text{C}$
- 32-pin 1.0 mm TQFP package

Functional Description

The CY29350 is a low-voltage high-performance 200-MHz PLL-based clock driver designed for high speed clock distribution applications.

The CY29350 features Xtal and LVCMOS reference clock inputs and provides nine outputs partitioned in four banks of 1, 1, 2, and 5 outputs. Bank A divides the VCO output by 2 or 4 while the other banks divide by 4 or 8 per SEL(A:D) settings, see [Function Table on page 4](#). These dividers allow output to input ratios of 16:1, 8:1, 4:1, and 2:1. Each LVCMOS compatible output can drive $50\ \Omega$ series or parallel terminated transmission lines. For series terminated transmission lines, each output can drive one or two traces giving the device an effective fanout of 1:18.

The PLL is ensured stable given that the VCO is configured to run between 200 MHz to 500 MHz. This allows a wide range of output frequencies from 25 MHz to 200 MHz. The internal VCO is running at multiples of the input reference clock set by the feedback divider, see [Frequency Table on page 4](#).

When PLL_EN is LOW, PLL is bypassed and the reference clock directly feeds the output dividers. This mode is fully static and the minimum input clock frequency specification does not apply.

Block Diagram

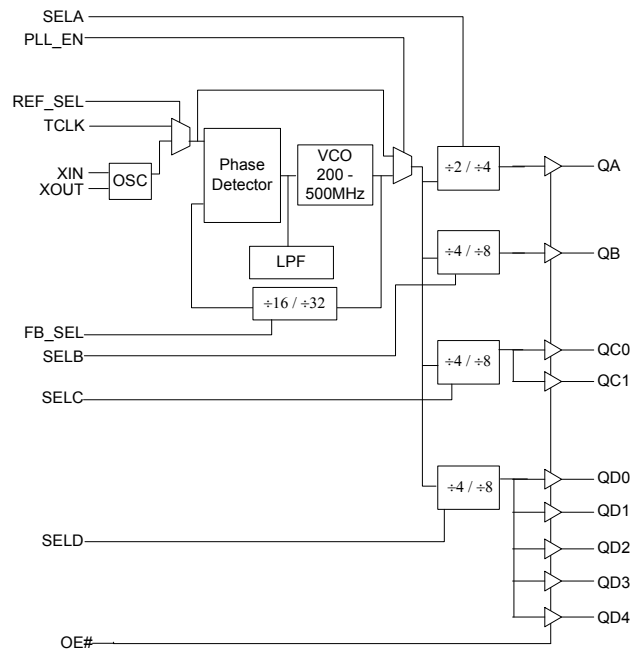

Contents

Pin Configuration	3	Package Drawing and Dimension	11
Pin Definitions	4	Acronyms	12
Frequency Table	4	Document Conventions	12
Function Table	4	Units of Measure	12
Absolute Maximum Conditions	5	Document History Page	13
DC Electrical Specifications	6	Sales, Solutions, and Legal Information	14
DC Electrical Specifications	6	Worldwide Sales and Design Support	14
AC Electrical Specifications	7	Products	14
AC Electrical Specifications	8	PSoC® Solutions	14
AC Test Loads	9	Cypress Developer Community	14
Switching Waveforms	9	Technical Support	14
Suggested Oscillator Crystal Parameters	9		
Ordering Information	10		
Ordering Code Definitions	10		

Pin Configuration

Figure 1. 32-pin TQFP pinout

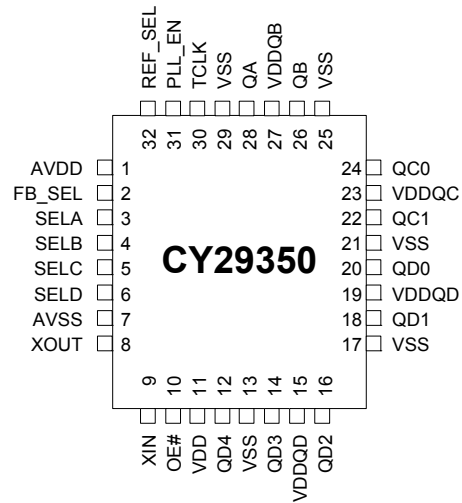

Pin Definitions

Pin	Name	I/O ^[1]	Type	Description
8	XOUT	O	Analog	Oscillator Output. Connect to a crystal.
9	XIN	I	Analog	Oscillator Input. Connect to a crystal.
30	TCLK	I, PD	LVC MOS	LVC MOS/LVTTL reference clock input
28	QA	O	LVC MOS	Clock output bank A
26	QB	O	LVC MOS	Clock output bank B
22, 24	QC(1:0)	O	LVC MOS	Clock output bank C
12, 14, 16, 18, 20	QD(4:0)	O	LVC MOS	Clock output bank D
2	FB_SEL	I, PD	LVC MOS	Internal Feedback Select Input. See Frequency Table .
10	OE#	I, PD	LVC MOS	Output enable/disable input. See Function Table .
31	PLL_EN	I, PU	LVC MOS	PLL enable/disable input. See Function Table .
32	REF_SEL	I, PD	LVC MOS	Reference select input. See Function Table .
3, 4, 5, 6	SEL(A:D)	I, PD	LVC MOS	Frequency select input, Bank (A:D). See Function Table .
27	VDDQB	Supply	VDD	2.5 V or 3.3 V Power supply for bank B output clock ^[2, 3]
23	VDDQC	Supply	VDD	2.5 V or 3.3 V Power supply for bank C output clocks ^[2, 3]
15, 19	VDDQD	Supply	VDD	2.5 V or 3.3 V Power supply for bank D output clocks ^[2, 3]
1	AVDD	Supply	VDD	2.5 V or 3.3 V Power supply for PLL ^[2, 3]
11	VDD	Supply	VDD	2.5 V or 3.3 V Power supply for core, inputs, and bank A output clock ^[2, 3]
7	AVSS	Supply	Ground	Analog ground
13, 17, 21, 25, 29	VSS	Supply	Ground	Common ground

Frequency Table

FB_SEL	Feedback Divider	VCO	Input Frequency Range (AVDD = 3.3 V)	Input Frequency Range (AVDD = 2.5 V)
0	÷32	Input Clock * 32	6.25 MHz to 15.625 MHz	6.25 MHz to 11.875 MHz
1	÷16	Input Clock * 16	12.5 MHz to 31.25 MHz	12.5 MHz to 23.75 MHz

Function Table

Control	Default	0	1
REF_SEL	0	Xtal	TCLK
PLL_EN	1	Bypass mode, PLL disabled. The input clock connects to the output dividers	PLL enabled. The VCO output connects to the output dividers
OE#	0	Outputs enabled	Outputs disabled (three-state)
FB_SEL	0	Feedback divider ÷ 32	Feedback divider ÷ 16
SELA	0	÷ 2 (Bank A)	÷ 4 (Bank A)
SELB	0	÷ 4 (Bank B)	÷ 8 (Bank B)
SELC	0	÷ 4 (Bank C)	÷ 8 (Bank C)
SELD	0	÷ 4 (Bank D)	÷ 8 (Bank D)

Notes

1. PU = Internal pull-up, PD = Internal pull-down.
2. A 0.1 μ F bypass capacitor should be placed as close as possible to each positive power pin (< 0.2"). If these bypass capacitors are not close to the pins their high frequency filtering characteristics will be cancelled by the lead inductance of the traces.
3. AVDD and VDD pins must be connected to a power supply level that is at least equal or higher than that of VDDQB, VDDQC, and VDDQD output power supply pins.

Absolute Maximum Conditions

Parameter	Description	Condition	Min	Max	Unit
V _{DD}	DC Supply Voltage		-0.3	5.5	V
V _{DD}	DC Operating Voltage	Functional	2.375	3.465	V
V _{IN}	DC Input Voltage	Relative to V _{SS}	-0.3	V _{DD} + 0.3	V
V _{OUT}	DC Output Voltage	Relative to V _{SS}	-0.3	V _{DD} + 0.3	V
V _{TT}	Output termination Voltage		-	V _{DD} ÷ 2	V
LU	Latch Up Immunity	Functional	200	-	mA
R _{PS}	Power Supply Ripple	Ripple Frequency < 100 kHz	-	150	mVp-p
T _S	Temperature, Storage	Non-functional	-65	+150	°C
T _A	Temperature, Operating Ambient	Functional	-40	+85	°C
T _J	Temperature, Junction	Functional	-	+150	°C
∅ _{JC}	Dissipation, Junction to Case	Functional	-	31	°C/W
∅ _{JA}	Dissipation, Junction to Ambient	Functional	-	61	°C/W
ESD _H	ESD Protection (Human Body Model)		2000	-	Volts
FIT	Failure in Time	Manufacturing test		10	ppm

DC Electrical Specifications

($V_{DD} = 2.5\text{ V} \pm 5\%$, $T_A = -40\text{ }^\circ\text{C}$ to $+85\text{ }^\circ\text{C}$)

Parameter	Description	Condition	Min	Typ	Max	Unit
V_{IL}	Input Voltage, Low	LVC MOS	–	–	0.7	V
V_{IH}	Input Voltage, High	LVC MOS	1.7	–	$V_{DD} + 0.3$	V
V_{OL}	Output Voltage, Low ^[4]	$I_{OL} = 15\text{ mA}$	–	–	0.6	V
V_{OH}	Output Voltage, High ^[4]	$I_{OH} = -15\text{ mA}$	1.8	–	–	V
I_{IL}	Input Current, Low ^[5]	$V_{IL} = V_{SS}$	–	–	-100	μA
I_{IH}	Input Current, High ^[5]	$V_{IL} = V_{DD}$	–	–	100	μA
I_{DDA}	PLL Supply Current	AVDD only	–	5	10	mA
I_{DDQ}	Quiescent Supply Current	All VDD pins except AVDD	–	–	7	mA
I_{DD}	Dynamic Supply Current	Outputs loaded @ 100 MHz	–	180	–	mA
		Outputs loaded @ 200 MHz	–	210	–	
C_{IN}	Input Pin Capacitance		–	4	–	pF
Z_{OUT}	Output Impedance		14	18	22	Ω

DC Electrical Specifications

($V_{DD} = 3.3\text{ V} \pm 5\%$, $T_A = -40\text{ }^\circ\text{C}$ to $+85\text{ }^\circ\text{C}$)

Parameter	Description	Condition	Min	Typ	Max	Unit
V_{IL}	Input Voltage, Low	LVC MOS	–	–	0.8	V
V_{IH}	Input Voltage, High	LVC MOS	2.0	–	$V_{DD} + 0.3$	V
V_{OL}	Output Voltage, Low ^[4]	$I_{OL} = 24\text{ mA}$	–	–	0.55	V
		$I_{OL} = 12\text{ mA}$	–	–	0.30	
V_{OH}	Output Voltage, High ^[4]	$I_{OH} = -24\text{ mA}$	2.4	–	–	V
I_{IL}	Input Current, Low ^[5]	$V_{IL} = V_{SS}$	–	–	-100	μA
I_{IH}	Input Current, High ^[5]	$V_{IL} = V_{DD}$	–	–	100	μA
I_{DDA}	PLL Supply Current	AVDD only	–	5	10	mA
I_{DDQ}	Quiescent Supply Current	All VDD pins except AVDD	–	–	7	mA
I_{DD}	Dynamic Supply Current	Outputs loaded @ 100 MHz	–	270	–	mA
		Outputs loaded @ 200 MHz	–	300	–	
C_{IN}	Input Pin Capacitance		–	4	–	pF
Z_{OUT}	Output Impedance		12	15	18	Ω

Notes

- Driving one 50 Ω parallel terminated transmission line to a termination voltage of V_{TT} . Alternatively, each output drives up to two 50 Ω series terminated transmission lines.
- Inputs have pull-up or pull-down resistors that affect the input current.

AC Electrical Specifications

($V_{DD} = 2.5 \text{ V} \pm 5\%$, $T_A = -40 \text{ }^\circ\text{C}$ to $+85 \text{ }^\circ\text{C}$) [6]

Parameter	Description	Condition	Min	Typ	Max	Unit
f_{VCO}	VCO Frequency		200	–	380	MHz
f_{in}	Input Frequency	± 16 Feedback	12.5	–	23.75	MHz
		± 32 Feedback	6.25	–	11.87	
		Bypass mode (PLL_EN = 0)	0	–	200	
f_{XTAL}	Crystal Oscillator Frequency		10	–	23.75	MHz
f_{refDC}	Input Duty Cycle		25	–	75	%
t_r, t_f	TCLK Input Rise/Fall Time	0.7 V to 1.7 V	–	–	1.0	ns
f_{MAX}	Maximum Output Frequency	± 2 Output	100	–	190	MHz
		± 4 Output	50	–	95	
		± 8 Output	25	–	47.5	
DC	Output Duty Cycle	$f_{MAX} < 100 \text{ MHz}$	47.5	–	52.5	%
		$f_{MAX} > 100 \text{ MHz}$	45	–	55	
t_r, t_f	Output Rise/Fall times	0.6 V to 1.8 V	0.1	–	1.0	ns
$t_{sk(O)}$	Output-to-Output Skew		–	–	150	ps
$t_{PLZ, HZ}$	Output Disable Time		–	–	10	ns
$t_{PZL, ZH}$	Output Enable Time		–	–	10	ns
BW	PLL Closed Loop Bandwidth (–3 dB)	± 16 Feedback	–	0.7–0.9	–	MHz
		± 32 Feedback	–	0.6–0.8	–	
$t_{JIT(CC)}$	Cycle-to-Cycle Jitter	Same frequency	–	–	150	ps
		Multiple frequencies	–	–	250	
$t_{JIT(PER)}$	Period Jitter	Same frequency	–	–	100	ps
		Multiple frequencies	–	–	175	
t_{LOCK}	Maximum PLL Lock Time		–	–	1	ms

Note

6. AC characteristics apply for parallel output termination of 50Ω to V_{TT} . Parameters are guaranteed by characterization and are not 100% tested.

AC Electrical Specifications

($V_{DD} = 3.3\text{ V} \pm 5\%$, $T_A = -40\text{ }^\circ\text{C}$ to $+85\text{ }^\circ\text{C}$) [7]

Parameter	Description	Condition	Min	Typ	Max	Unit
f_{VCO}	VCO Frequency		200	–	500	MHz
f_{in}	Input Frequency	+16 Feedback	12.5	–	31.25	MHz
		+32 Feedback	6.25	–	15.625	
		Bypass mode (PLL_EN = 0)	0	–	200	
f_{XTAL}	Crystal Oscillator Frequency		10	–	25	MHz
f_{refDC}	Input Duty Cycle		25	–	75	%
t_r, t_f	TCLK Input Rise/Fall Time	0.8 V to 2.0 V	–	–	1.0	ns
f_{MAX}	Maximum Output Frequency	+2 Output	100	–	200	MHz
		+4 Output	50	–	125	
		+8 Output	25	–	62.5	
DC	Output Duty Cycle	$f_{MAX} < 100\text{ MHz}$	47.5	–	52.5	%
		$f_{MAX} > 100\text{ MHz}$	45	–	55	
t_r, t_f	Output Rise/Fall times	0.8 V to 2.4 V	0.1	–	1.0	ns
$t_{sk(O)}$	Output-to-Output Skew	Banks at same voltage	–	–	150	ps
$t_{sk(B)}$	Bank-to-Bank Skew	Banks at different voltages	–	–	350	ps
$t_{PLZ, HZ}$	Output Disable Time		–	–	10	ns
$t_{PZL, ZH}$	Output Enable Time		–	–	10	ns
BW	PLL Closed Loop Bandwidth (–3 dB)	+16 Feedback	–	0.7–0.9	–	MHz
		+32 Feedback	–	0.6–0.8	–	
$t_{JIT(CC)}$	Cycle-to-Cycle Jitter	Same frequency	–	–	150	ps
		Multiple frequencies	–	–	250	
$t_{JIT(PER)}$	Period Jitter	Same frequency	–	–	100	ps
		Multiple frequencies	–	–	150	
t_{LOCK}	Maximum PLL Lock Time		–	–	1	ms

Note

7. AC characteristics apply for parallel output termination of $50\ \Omega$ to V_{TT} . Parameters are guaranteed by characterization and are not 100% tested.

AC Test Loads

Figure 2. AC Test Reference for $V_{DD} = 3.3\text{ V} / 2.5\text{ V}$

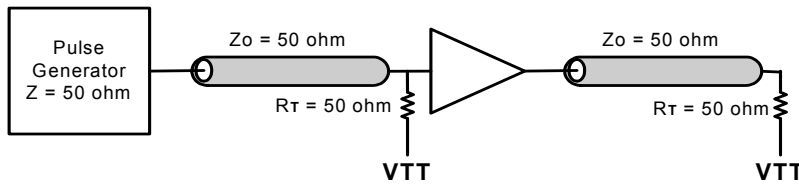

Switching Waveforms

Figure 3. Output Duty Cycle (DC)

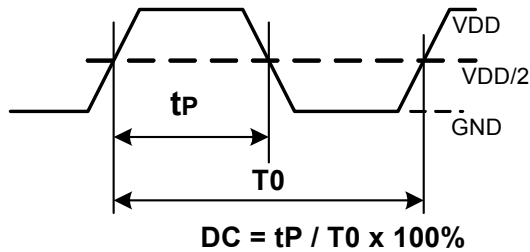
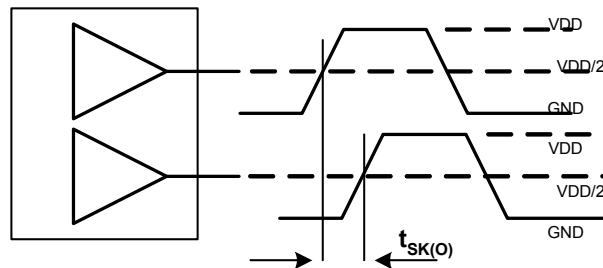

Figure 4. Output-to-Output Skew, $t_{sk(O)}$



Suggested Oscillator Crystal Parameters

Characteristic	Parameter	Conditions	Min	Typ	Max	Units
Frequency Tolerance	T_C		–	–	±100	ppm
Frequency Temperature Stability	T_S	(T_A , $-10\text{ }^\circ\text{C}$ to $+60\text{ }^\circ\text{C}$)	–	–	±00	ppm
Aging	T_A	First three years @ $25\text{ }^\circ\text{C}$	–	–	5	ppm/yr
Load Capacitance	C_L	Crystal's rated load	–	20	–	pF
Effective Series Resistance	R_{ESR}		–	40	80	Ω

Ordering Information

Part Number	Package Type	Product Flow
CY29350AXI	32-pin TQFP, Pb-free	Industrial, -40 °C to +85 °C
CY29350AXIT	32-pin TQFP – Tape and Reel, Pb-free	Industrial, -40 °C to 85 °C

Ordering Code Definitions

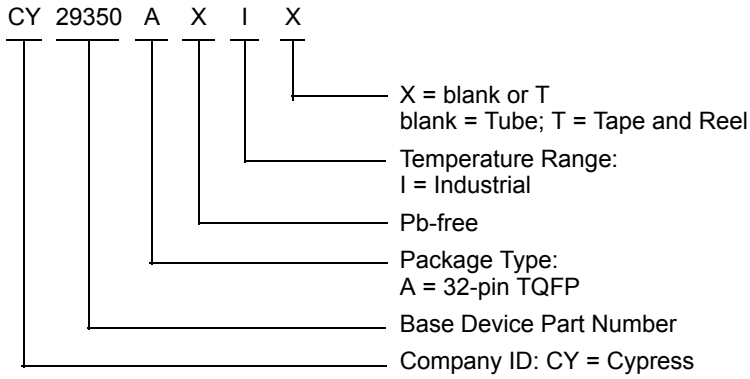

Package Drawing and Dimension

Figure 5. 32-pin TQFP (7 × 7 × 1.0 mm) Package Outline, 51-85063

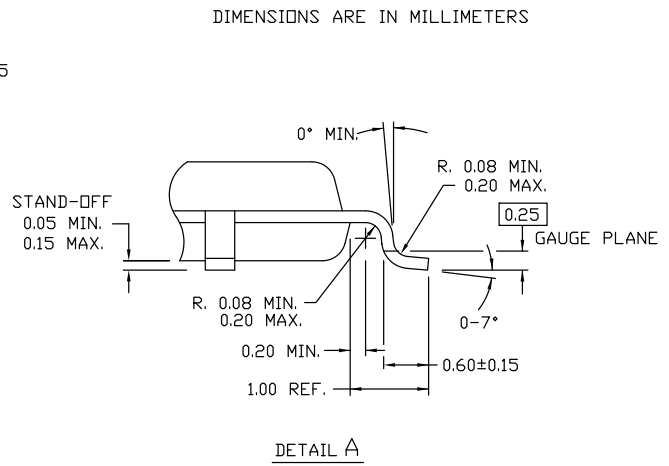
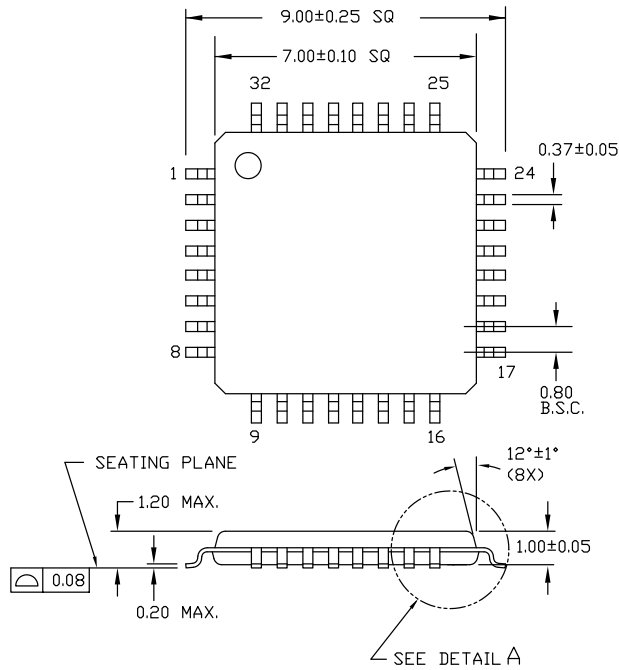

51-85063 *D

Acronyms

Acronym	Description
CMOS	Complementary Metal Oxide Semiconductor
ESD	Electrostatic Discharge
I/O	Input/Output
LVC MOS	Low Voltage Complementary Metal Oxide Semiconductor
LV TTL	Low Voltage Transistor-Transistor Logic
PLL	Phase-Locked Loop
TQFP	Thin Quad Flat Pack
VCO	Voltage-Controlled Oscillator

Document Conventions

Units of Measure

Symbol	Unit of Measure
°C	degree Celsius
Hz	hertz
kHz	kilohertz
kV	kilovolt
MHz	megahertz
µF	microfarad
µA	microampere
mm	millimeter
mA	milliampere
ms	millisecond
mV	millivolt
ns	nanosecond
Ω	ohm
ppm	parts per million
%	percent
pF	picofarad
ps	picosecond
V	volt
W	watt

Document History Page

Document Title: CY29350, 2.5 V or 3.3 V, 200-MHz, 9-Output Clock Driver Document Number: 38-07474				
Rev.	ECN No.	Issue Date	Orig. of Change	Description of Change
**	128104	07/07/03	RGL	New data sheet.
*A	245393	See ECN	RGL	Updated Function Table : Re-worded Select Function Descriptions.
*B	2904632	04/05/2010	KVM	Updated Ordering Information : The existing part numbers in Part Number column are replaced with new ones namely CY29350AXI and CY29350AXIT. Also updated details in Package Type column as follows: 32-pin TQFP, Pb-free for CY29350AXI. 32-pin TQFP – Tape and Reel, Pb-free for CY29350AXIT.
*C	3223621	04/12/2011	BASH	Added Ordering Code Definitions . Added Acronyms and Units of Measure . Updated in new template.
*D	4345036	04/15/2014	XHT	Updated Absolute Maximum Conditions : Updated values of θ_{JC} and θ_{JA} parameters. Updated Package Drawing and Dimension : spec 51-85063 – Changed revision from *C to *D. Updated in new template. Completing Sunset Review.

Sales, Solutions, and Legal Information

Worldwide Sales and Design Support

Cypress maintains a worldwide network of offices, solution centers, manufacturer's representatives, and distributors. To find the office closest to you, visit us at [Cypress Locations](#).

Products

Automotive	cypress.com/go/automotive
Clocks & Buffers	cypress.com/go/clocks
Interface	cypress.com/go/interface
Lighting & Power Control	cypress.com/go/powerpsoc cypress.com/go/plc
Memory	cypress.com/go/memory
PSoC	cypress.com/go/psoc
Touch Sensing	cypress.com/go/touch
USB Controllers	cypress.com/go/USB
Wireless/RF	cypress.com/go/wireless

PSoC[®] Solutions

[psoc.cypress.com/solutions](#)
[PSoC 1](#) | [PSoC 3](#) | [PSoC 4](#) | [PSoC 5LP](#)

Cypress Developer Community

[Community](#) | [Forums](#) | [Blogs](#) | [Video](#) | [Training](#)

Technical Support

[cypress.com/go/support](#)

© Cypress Semiconductor Corporation, 2003-2014. The information contained herein is subject to change without notice. Cypress Semiconductor Corporation assumes no responsibility for the use of any circuitry other than circuitry embodied in a Cypress product. Nor does it convey or imply any license under patent or other rights. Cypress products are not warranted nor intended to be used for medical, life support, life saving, critical control or safety applications, unless pursuant to an express written agreement with Cypress. Furthermore, Cypress does not authorize its products for use as critical components in life-support systems where a malfunction or failure may reasonably be expected to result in significant injury to the user. The inclusion of Cypress products in life-support systems application implies that the manufacturer assumes all risk of such use and in doing so indemnifies Cypress against all charges.

Any Source Code (software and/or firmware) is owned by Cypress Semiconductor Corporation (Cypress) and is protected by and subject to worldwide patent protection (United States and foreign), United States copyright laws and international treaty provisions. Cypress hereby grants to licensee a personal, non-exclusive, non-transferable license to copy, use, modify, create derivative works of, and compile the Cypress Source Code and derivative works for the sole purpose of creating custom software and or firmware in support of licensee product to be used only in conjunction with a Cypress integrated circuit as specified in the applicable agreement. Any reproduction, modification, translation, compilation, or representation of this Source Code except as specified above is prohibited without the express written permission of Cypress.

Disclaimer: CYPRESS MAKES NO WARRANTY OF ANY KIND, EXPRESS OR IMPLIED, WITH REGARD TO THIS MATERIAL, INCLUDING, BUT NOT LIMITED TO, THE IMPLIED WARRANTIES OF MERCHANTABILITY AND FITNESS FOR A PARTICULAR PURPOSE. Cypress reserves the right to make changes without further notice to the materials described herein. Cypress does not assume any liability arising out of the application or use of any product or circuit described herein. Cypress does not authorize its products for use as critical components in life-support systems where a malfunction or failure may reasonably be expected to result in significant injury to the user. The inclusion of Cypress' product in a life-support systems application implies that the manufacturer assumes all risk of such use and in doing so indemnifies Cypress against all charges.

Use may be limited by and subject to the applicable Cypress software license agreement.

X-ON Electronics

Largest Supplier of Electrical and Electronic Components

Click to view similar products for [Phase Locked Loops - PLL category](#):

Click to view products by [Cypress manufacturer](#):

Other Similar products are found below :

[ADF4152HVBCPZ-RL7](#) [HMC440QS16GTR](#) [LC72135MA-Q-AE](#) [SL28EB725ALI](#) [HMC699LP5ETR](#) [HMC700LP4TR](#) [LC7185-8750-E](#)
[MB15E07SLPFV1-G-BND-6E1](#) [XRT8001ID-F](#) [ATA8404C-6DQY-66](#) [PI6C2409-1HWE](#) [ATA8405C-6DQY-66](#) [MAX2870ETJ+T](#)
[PI6C2409-1HWEX](#) [CYW170-01SXC](#) [HMC764LP6CETR](#) [HMC767LP6CETR](#) [HMC820LP6CETR](#) [HMC828LP6CETR](#) [HMC834LP6GETR](#)
[ispPAC-CLK5410D-01SN64C](#) [SI4113-D-GM](#) [82V3002APVG](#) [PI6C2405A-1WE](#) [CY22050KFI](#) [CY25200KFZXC](#) [CY29973AXI](#)
[CY2XP22ZXI](#) [W232ZXC-10](#) [CDCE937QPWRQ1](#) [CY2077FZXI](#) [CY2546FC](#) [CY2XF23FLXIT](#) [CYISM560BSXC](#) [LMX2430TMX/NOPB](#)
[HMC837LP6CETR](#) [HMC831LP6CETR](#) [ATA8404C-6DQY-66](#) [ADF4155BCPZ-RL7](#) [MB15E07SRPFT-G-BNDE1](#) [NB3N5573DTG](#)
[MAX2660EUT+T](#) [SI4123-D-GT](#) [SI4112-D-GM](#) [NB4N441MNR2G](#) [ADF4116BRUZ-REEL7](#) [ADF4153ABCPZ](#) [MAX2682EUT+T](#) [Si5376B-](#)
[A-GL](#) [SI5347A-A-GM](#)