



Ultra37000 CPLD Family

5 V and 3.3 V ISR™ High Performance CPLDs

Features

- In-System Reprogrammable™ (ISR™) CMOS CPLDs
 - JTAG interface for reconfigurability
 - Design changes do not cause pinout changes
 - Design changes do not cause timing changes
- High Density
 - 32 to 512 macrocells
 - 32 to 264 I/O pins
 - 5 dedicated inputs including 4 clock pins
- Simple Timing Model
 - No fanout delays
 - No expander delays
 - No dedicated vs. I/O pin delays
 - No additional delay through PIM
 - No penalty for using full 16 product terms
 - No delay for steering or sharing product terms
- 3.3 V and 5 V Versions
- PCI Compatible ^[1]
- Programmable Bus-hold Capabilities on All I/Os
- Intelligent Product Term Allocator Provides
 - 0 to 16 product terms to any macrocell
 - Product term steering on an individual basis
 - Product term sharing among local macrocells
- Flexible Clocking
 - 4 synchronous clocks per device
 - Product term clocking
 - Clock polarity control per logic block
- Consistent Package and Pinout Offering across All Densities
 - Simplifies design migration
 - Same pinout for 3.3 V and 5 V devices
- Packages
 - 44 to 256 pins in PLCC, PQFP, TQFP, and Fine-Pitch BGA Packages
 - Pb-free packages available

General Description

The Ultra37000™ family of CMOS CPLDs provides a range of high density programmable logic solutions with unparalleled system performance. The Ultra37000 family is designed to bring the flexibility, ease of use, and performance of the 22 V10 to high density CPLDs. The architecture is based on a number of logic blocks that are connected by a Programmable Interconnect Matrix (PIM). Each logic block features its own product term array, product term allocator, and 16 macrocells. The PIM distributes signals from the logic block outputs and all input pins to the logic block inputs.

All the Ultra37000 devices are electrically erasable and In-System Reprogrammable (ISR), which simplifies both design and manufacturing flows, thereby reducing costs. The ISR feature provides the ability to reconfigure the devices without having design changes cause pinout or timing changes. The Cypress ISR function is implemented through a JTAG-compliant serial interface. Data is shifted in and out through the TDI and TDO pins, respectively. Because of the superior routability and simple timing model of the Ultra37000 devices, ISR allows users to change existing logic designs while simultaneously fixing pinout assignments and maintaining system performance.

The entire family features JTAG for ISR and boundary scan, and is compatible with the PCI Local Bus specification, meeting the electrical and timing requirements. The Ultra37000 family features user programmable bus-hold capabilities on all I/Os.

Ultra37000 5 V Devices

The Ultra37000 devices operate with a 5 V supply and can support 5 V or 3.3 V I/O levels. V_{CCO} connections provide the capability of interfacing to either a 5 V or 3.3 V bus. By connecting the V_{CCO} pins to 5 V the user insures 5V TTL levels on the outputs. If V_{CCO} is connected to 3.3 V the output levels meet 3.3 V JEDEC standard CMOS levels and are 5 V tolerant. These devices require 5 V ISR programming.

Ultra37000V 3.3 V Devices

Devices operating with a 3.3 V supply require 3.3 V on all V_{CCO} pins, reducing the device's power consumption. These devices support 3.3 V JEDEC standard CMOS output levels, and are 5V-tolerant. These devices allow 3.3 V ISR programming.

Note

1. Due to the 5 V tolerant nature of 3.3 V device I/Os, the I/Os are not clamped to V_{CC} , $PCI V_{IH} = 2 V$.

Contents

Logic Block Diagrams	3	Endurance Characteristics	20
Selection Guide	6	3.3 V Device Maximum Ratings	21
5 V Selection Guide	6	Operating Range	21
3.3 V Selection Guide	7	3.3 V Device Electrical Characteristics	21
Pin Configurations	8	Inductance	22
Architecture Overview of Ultra37000 Family	13	Capacitance	22
Programmable Interconnect Matrix	13	Endurance Characteristics	22
Logic Block	13	AC Test Loads and Waveforms	23
Product Term Allocator	14	Switching Characteristics	25
Ultra37000 Macrocell	14	Switching Characteristics	27
Clocking	16	Switching Waveforms	30
Timing Model	16	Power Consumption	34
JTAG and PCI Standards	17	Typical 5 V Power Consumption	34
PCI Compliance	17	Typical 3.3 V Power Consumption	37
IEEE 1149.1-compliant JTAG	17	Ordering Information	40
Development Software Support	17	5 V Ordering Information	40
Warp	17	3.3 V Ordering Information	40
Warp Professional™	17	Ordering Code Definitions	41
Warp Enterprise™	17	Package Diagrams	42
Third-Party Software	17	Acronyms	45
Programming	17	Document Conventions	45
Third-Party Programmers	18	Units of Measure	45
5 V Device Maximum Ratings	19	Document History Page	46
Operating Range	19	Sales, Solutions, and Legal Information	50
5 V Device Electrical Characteristics	19	Worldwide Sales and Design Support	50
Inductance	20	Products	50
Capacitance	20	PSoC Solutions	50

Logic Block Diagrams

CY37032/CY37032V

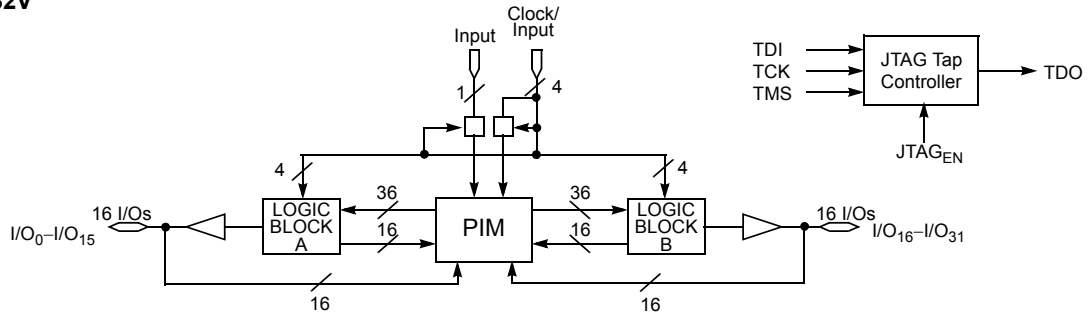

CY37064/CY37064V

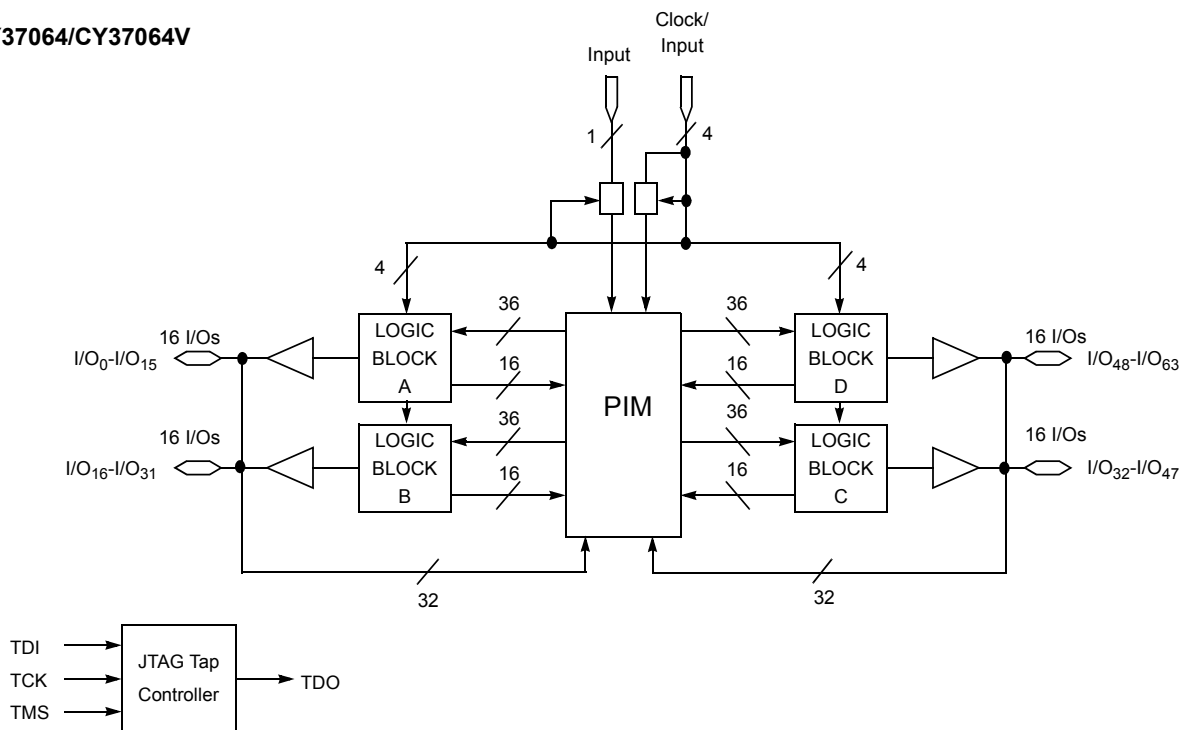

"Not Recommended for New Design"

Logic Block Diagrams (continued)

CY37128/CY37128V

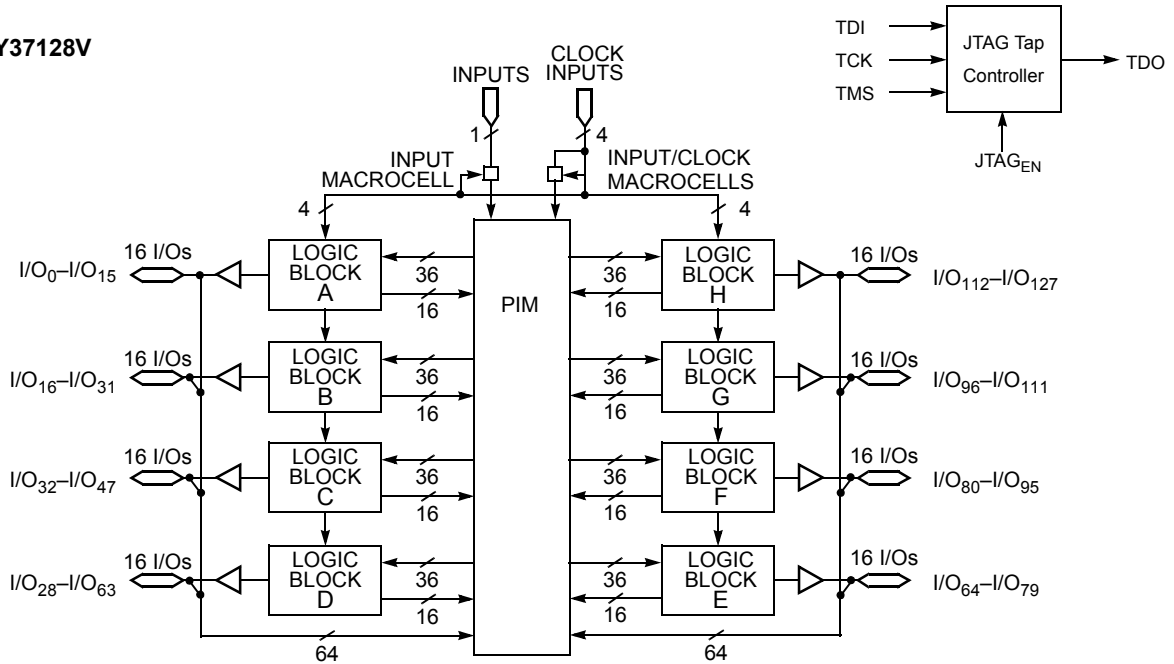

CY37192/CY37192V

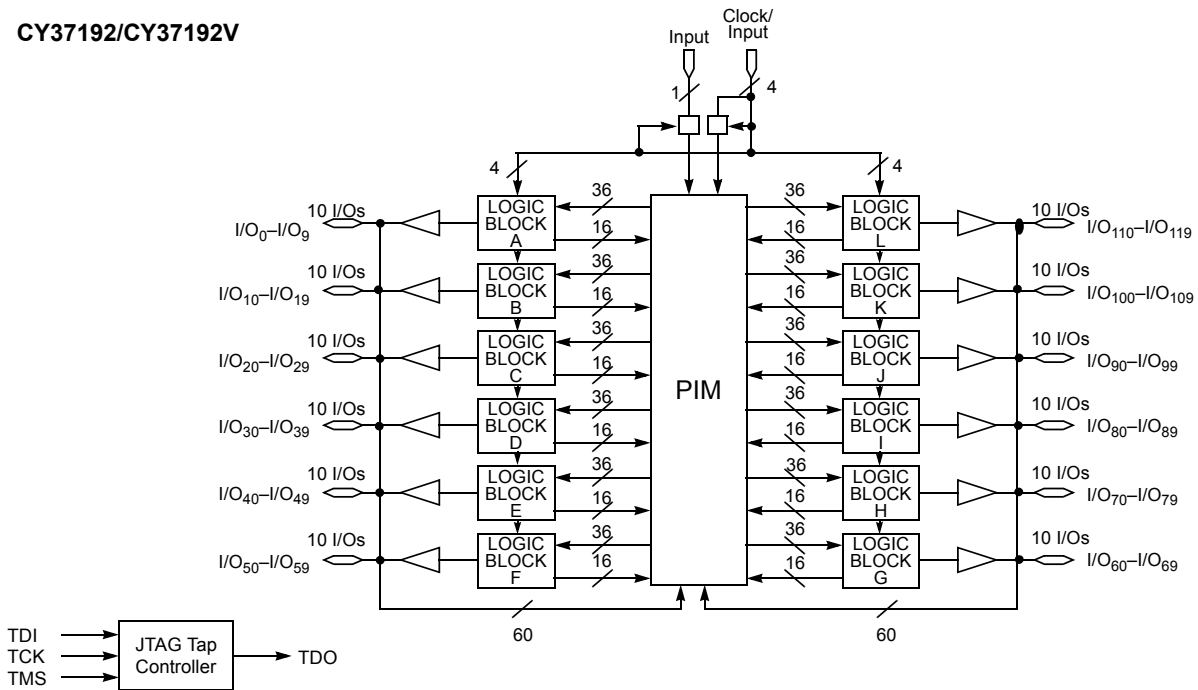

"Not Recommended for New Design"

Logic Block Diagrams (continued)

CY37256/CY37256V

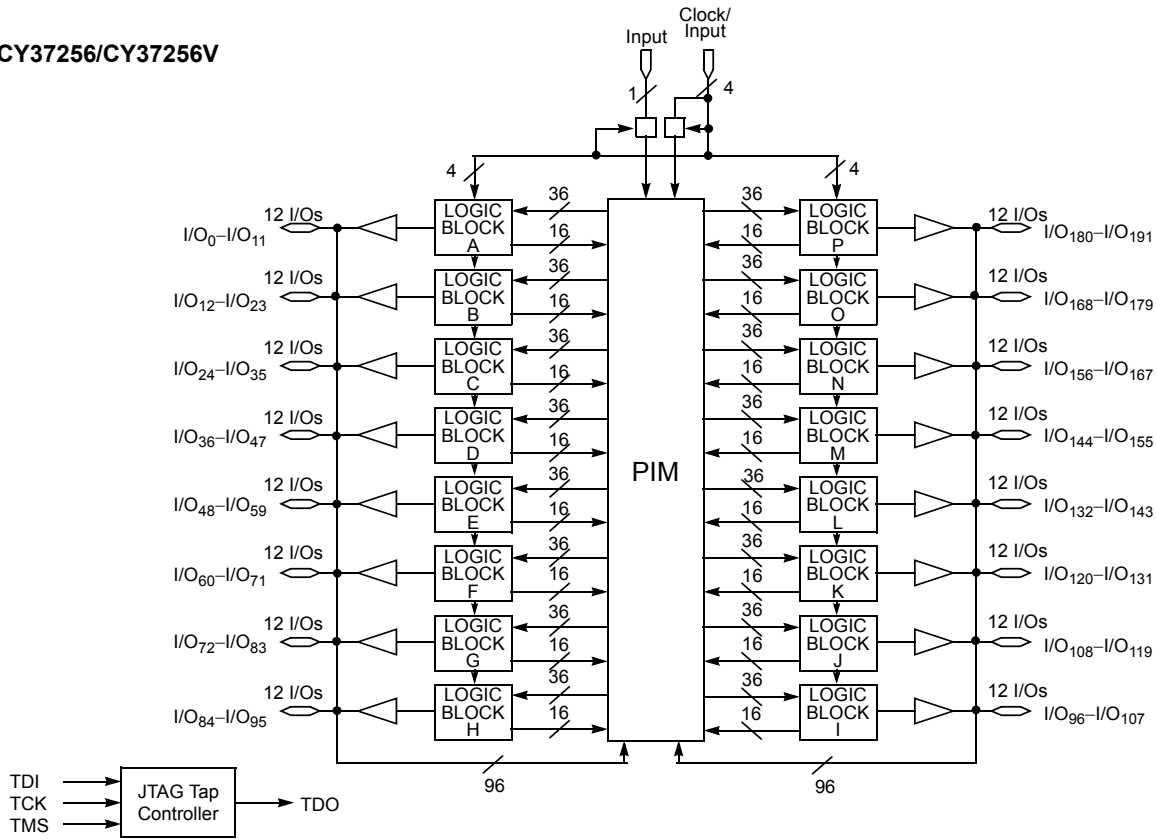

"Not Recommended for New Design"

Selection Guide

5 V Selection Guide

Table 1. General Information

Device	Macrocells	Dedicated Inputs	I/O Pins	Speed (t _{PD})	Speed (f _{MAX})
CY37032	32	5	32	6	200
CY37064	64	5	32/64	6	200
CY37128	128	5	64/128	6.5	167
CY37192	192	5	120	7.5	154
CY37256	256	5	128/160/192	7.5	154

Table 2. Speed Bins

Device	200	167	154	125	100	83
CY37032			X	X		
CY37064	X		X	X		
CY37128		X		X	X	
CY37192				X		X
CY37256				X		X

Table 3. Device-Package Offering and I/O Count

Device	44-pin TQFP	44-pin PLCC	100-pin TQFP	160-pin TQFP
CY37032	37	37		
CY37064	37	37	69	
CY37128			69	133
CY37192				125
CY37256				133

"Not Recommended for New Design"

3.3 V Selection Guide
Table 4. General Information

Device	Macrocells	Dedicated Inputs	I/O Pins	Speed (t _{PD})	Speed (f _{MAX})
CY37032V	32	5	32	8.5	143
CY37064V	64	5	32/64	8.5	143
CY37128V	128	5	64/80/128	10	125
CY37192V	192	5	120	12	100
CY37256V	256	5	128/160/192	12	100

Table 5. Speed Bins

Device	143	125	100	83	66
CY37032V	X		X		
CY37064V	X		X		
CY37128V		X		X	
CY37192V			X		X
CY37256V			X		X

Table 6. Device-Package Offering and I/O Count

Device	44-pin TQFP	100-pin TQFP	160-pin TQFP	256-ball FBGA
CY37032V	37			
CY37064V	37	69		
CY37128V		69	133	
CY37192V			125	
CY37256V			133	197

"Not Recommended for New Design"

Pin Configurations

The Pin Configurations are as follows. [2]

Figure 1. 44-pin TQFP pinout (Top View)

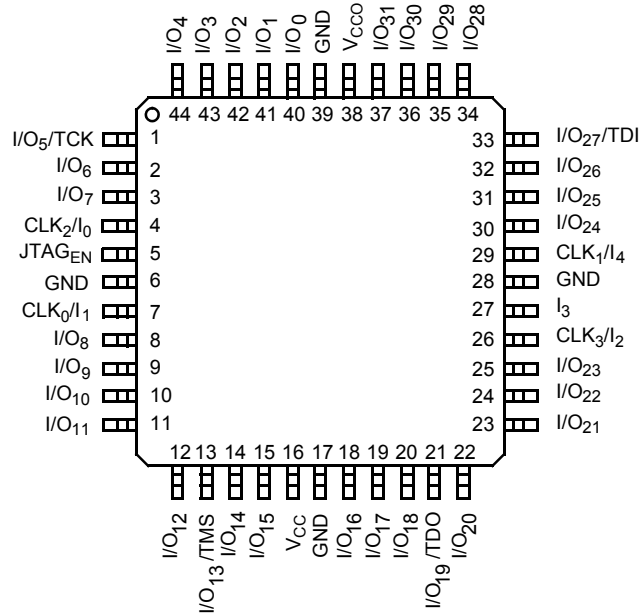
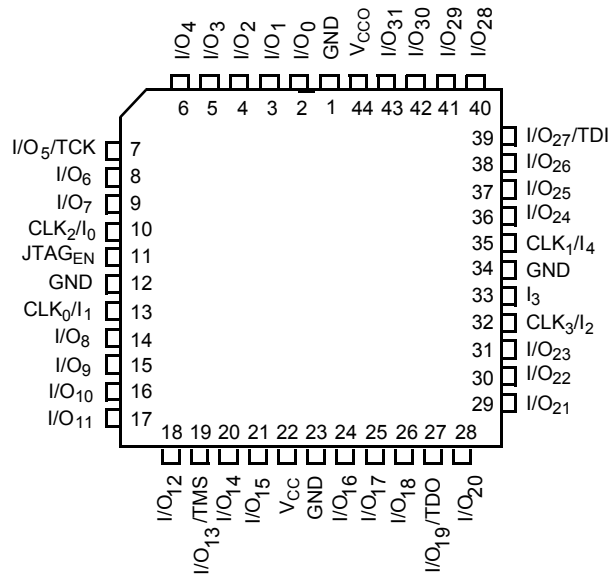

Figure 2. 44-pin PLCC pinout (Top View)



Note

2. For 3.3 V versions (Ultra37000V), V_{CC0} = V_{CC}.

"Not Recommended for New Design"

Pin Configurations (continued)

The Pin Configurations are as follows. [2]

Figure 3. 100-pin TQFP pinout (Top View)

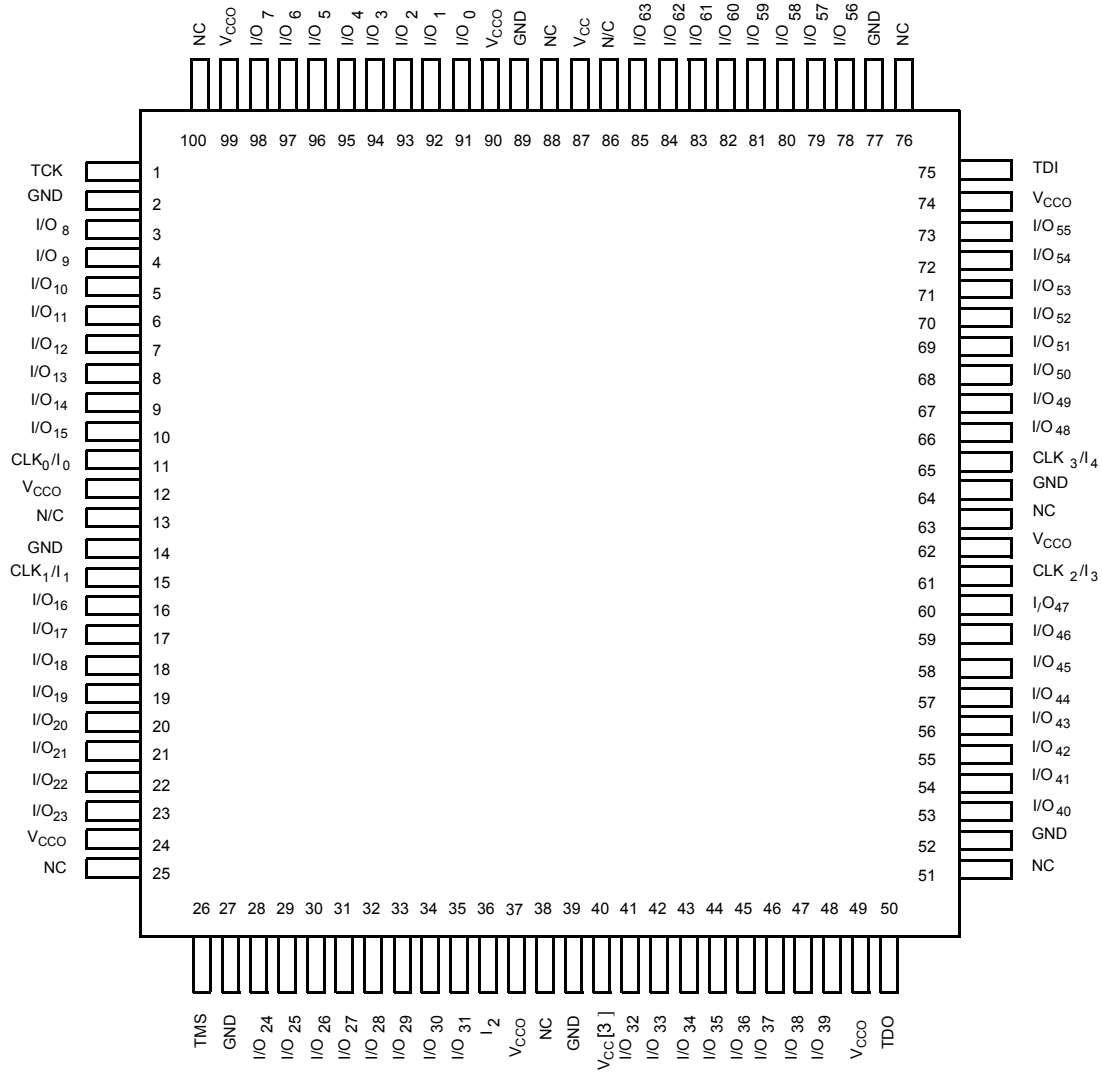

"Not Recommended for New Design"

Note

3. This pin is a N/C, but Cypress recommends that you connect it to V_{CC} to ensure future compatibility.

Pin Configurations (continued)

The Pin Configurations are as follows. [2]

Figure 4. 160-pin TQFP pinout (Top View)

For CY37128(V) and CY37256(V)

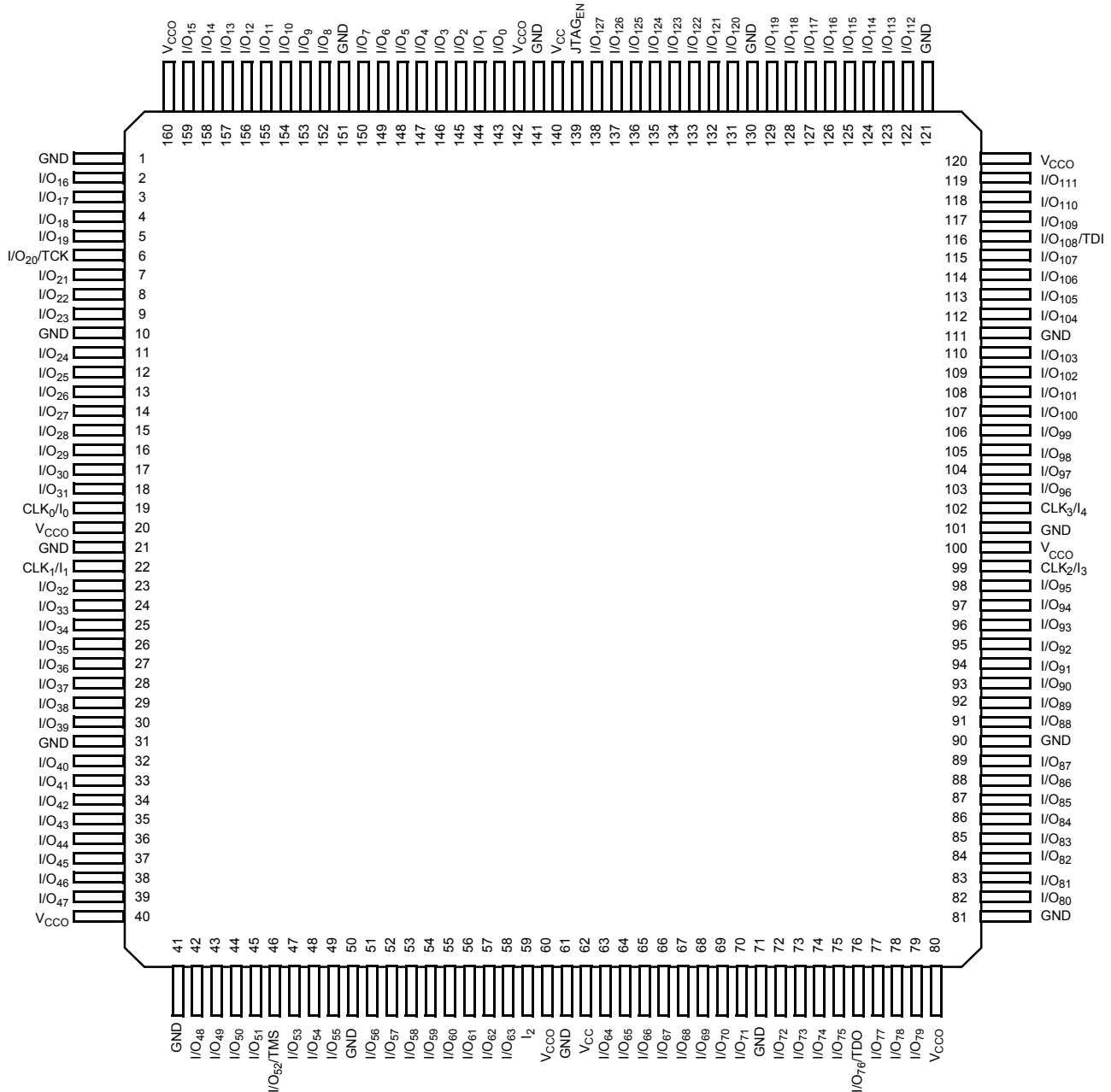

"Not Recommended for New Design"

Pin Configurations (continued)

The Pin Configurations are as follows. [2]

Figure 5. 160-pin TQFP pinout (Top View)

For CY37192(V)

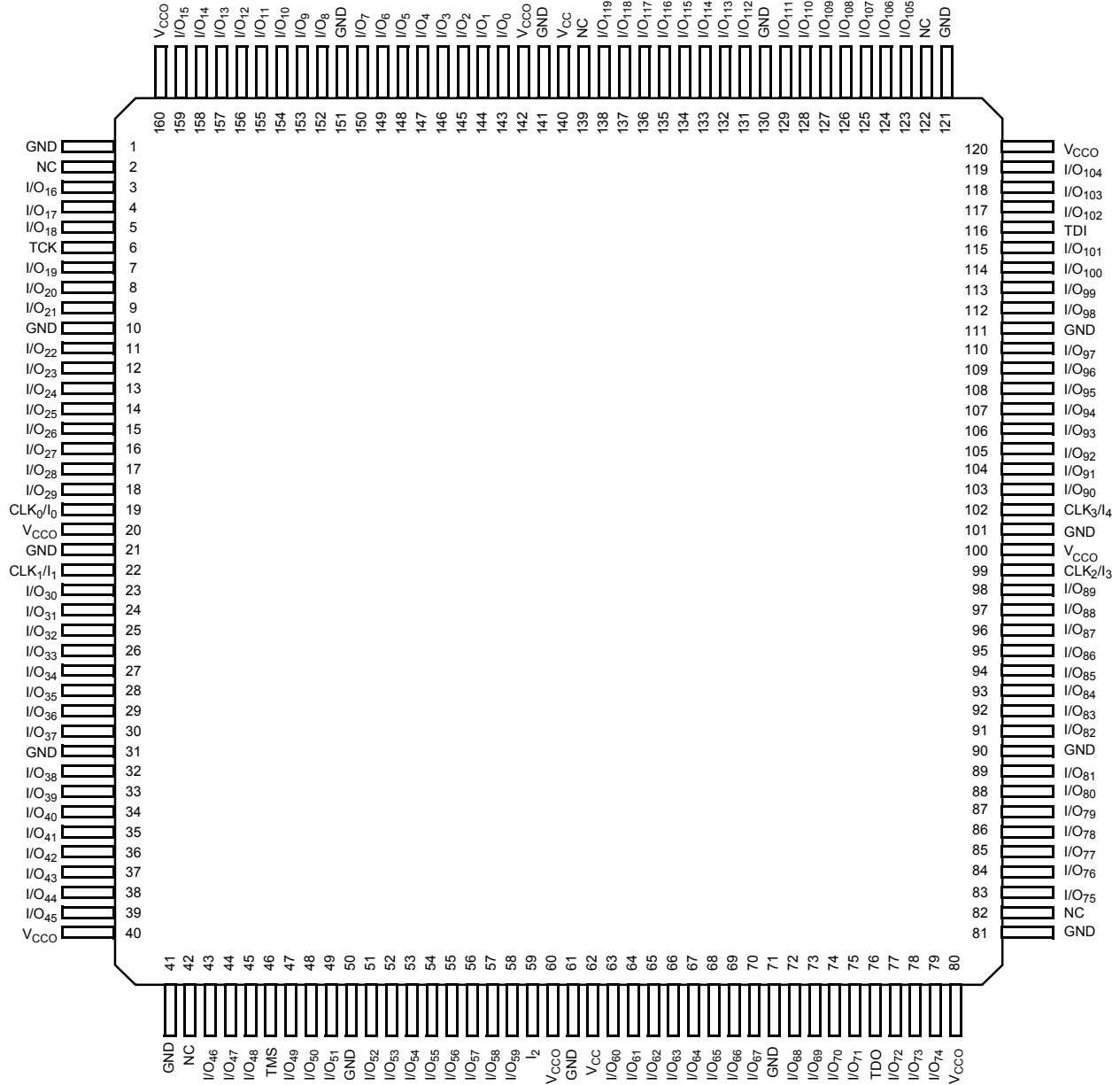

"Not Recommended for New Design"

Pin Configurations (continued)

The Pin Configurations are as follows. [2]

Figure 6. 256-ball FBGA pinout (Top View)

	1	2	3	4	5	6	7	8	9	10	11	12	13	14	15	16
A	GND	GND	I/O ₂₆	I/O ₂₄	I/O ₂₀	V _{CC}	I/O ₁₁	GND	GND	I/O ₁₈₆	V _{CC}	I/O ₁₇₇	I/O ₁₇₂	I/O ₁₆₇	GND	GND
B	GND	I/O ₂₇	I/O ₂₅	I/O ₂₃	I/O ₁₉	I/O ₁₅	I/O ₁₀	GND	GND	I/O ₁₈₅	I/O ₁₈₁	I/O ₁₇₆	I/O ₁₇₁	I/O ₁₆₆	I/O ₁₆₅	GND
C	I/O ₂₉	I/O ₂₈	NC	I/O ₂₂	I/O ₁₈	I/O ₁₄	I/O ₉	I/O ₄	I/O ₁₉₁	I/O ₁₈₄	I/O ₁₈₀	I/O ₁₇₅	I/O ₁₇₀	NC	I/O ₁₆₃	I/O ₁₆₄
D	I/O ₃₂	I/O ₃₁	I/O ₃₀	NC	I/O ₁₇	I/O ₁₃	I/O ₈	I/O ₃	I/O ₁₉₀	I/O ₁₈₃	I/O ₁₇₉	I/O ₁₇₄	I/O ₁₆₉	I/O ₁₆₀	I/O ₁₆₁	I/O ₁₆₂
E	I/O ₃₅	I/O ₃₄	I/O ₃₃	I/O ₂₁	I/O ₁₆	I/O ₁₂	I/O ₇	I/O ₂	I/O ₁₈₉	V _{CC}	I/O ₁₇₈	I/O ₁₇₃	I/O ₁₆₈	I/O ₁₅₇	I/O ₁₅₈	I/O ₁₅₉
F	V _{CC}	I/O ₃₈	I/O ₃₇	I/O ₃₆	TCK	V _{CC}	I/O ₆	I/O ₁	I/O ₁₈₈	I/O ₁₈₂	V _{CC}	TDI	I/O ₁₅₄	I/O ₁₅₅	I/O ₁₅₆	V _{CC}
G	I/O ₄₃	I/O ₄₂	I/O ₄₁	I/O ₄₀	V _{CC}	I/O ₃₉	I/O ₅	I/O ₀	I/O ₁₈₇	I/O ₁₄₈	I/O ₁₄₉	CLK ₃ / I ₄	I/O ₁₅₀	I/O ₁₅₁	I/O ₁₅₂	I/O ₁₅₃
H	GND	GND	I/O ₄₇	I/O ₄₆	CLK ₀ / I ₀	I/O ₄₅	I/O ₄₄	GND	GND	I/O ₁₄₄	I/O ₁₄₅	CLK ₂ / I ₃	I/O ₁₄₆	I/O ₁₄₇	GND	GND
J	GND	GND	I/O ₅₁	I/O ₅₀	NC	I/O ₄₉	I/O ₄₈	GND	GND	I/O ₁₄₀	I/O ₁₄₁	I ₂	I/O ₁₄₂	I/O ₁₄₃	GND	GND
K	I/O ₅₇	I/O ₅₆	I/O ₅₅	I/O ₅₄	CLK ₁ / I ₁	I/O ₅₃	I/O ₅₂	I/O ₉₁	I/O ₉₆	I/O ₁₀₁	I/O ₁₃₅	V _{CC}	I/O ₁₃₆	I/O ₁₃₇	I/O ₁₃₈	I/O ₁₃₉
L	V _{CC}	I/O ₆₀	I/O ₅₉	I/O ₅₈	TMS	V _{CC}	I/O ₈₆	I/O ₉₂	I/O ₉₇	I/O ₁₀₂	V _{CC}	TDO	I/O ₁₃₂	I/O ₁₃₃	I/O ₁₃₄	V _{CC}
M	I/O ₆₃	I/O ₆₂	I/O ₆₁	I/O ₇₂	I/O ₇₇	I/O ₈₂	V _{CC}	I/O ₉₃	I/O ₉₈	I/O ₁₀₃	I/O ₁₀₈	I/O ₁₁₂	I/O ₁₁₇	I/O ₁₂₉	I/O ₁₃₀	I/O ₁₃₁
N	I/O ₆₆	I/O ₆₅	I/O ₆₄	I/O ₇₃	I/O ₇₈	I/O ₈₃	I/O ₈₇	I/O ₉₄	I/O ₉₉	I/O ₁₀₄	I/O ₁₀₉	I/O ₁₁₃	NC	I/O ₁₂₆	I/O ₁₂₇	I/O ₁₂₈
P	I/O ₆₈	I/O ₆₇	NC	I/O ₇₄	I/O ₇₉	I/O ₈₄	I/O ₈₈	I/O ₉₅	I/O ₁₀₀	I/O ₁₀₅	I/O ₁₁₀	I/O ₁₁₄	I/O ₁₁₈	NC	I/O ₁₂₄	I/O ₁₂₅
R	GND	I/O ₆₉	I/O ₇₀	I/O ₇₅	I/O ₈₀	I/O ₈₅	I/O ₈₉	GND	GND	I/O ₁₀₆	I/O ₁₁₁	I/O ₁₁₅	I/O ₁₁₉	I/O ₁₂₁	I/O ₁₂₃	GND
T	GND	GND	I/O ₇₁	I/O ₇₆	I/O ₈₁	V _{CC}	I/O ₉₀	GND	GND	I/O ₁₀₇	V _{CC}	I/O ₁₁₆	I/O ₁₂₀	I/O ₁₂₂	GND	GND

"Not Recommended for New Design"

Architecture Overview of Ultra37000 Family

Programmable Interconnect Matrix

The PIM consists of a completely global routing matrix for signals from I/O pins and feedbacks from the logic blocks. The PIM provides extremely robust interconnection to avoid fitting and density limitations.

The inputs to the PIM consist of all I/O and dedicated input pins and all macrocell feedbacks from within the logic blocks. The number of PIM inputs increases with pin count and the number of logic blocks. The outputs from the PIM are signals routed to the appropriate logic blocks. Each logic block receives 36 inputs from the PIM and their complements, allowing for 32-bit operations to be implemented in a single pass through the device. The wide number of inputs to the logic block also improves the routing capacity of the Ultra37000 family.

An important feature of the PIM is its simple timing. The propagation delay through the PIM is accounted for in the timing specifications for each device. There is no additional delay for traveling through the PIM. In fact, all inputs travel through the PIM. As a result, there are no route-dependent timing parameters on the Ultra37000 devices. The worst-case PIM delays are incorporated in all appropriate Ultra37000 specifications.

Routing signals through the PIM is completely invisible to the user. All routing is accomplished by software — no hand routing is necessary. *Warp*[®] and third-party development packages automatically route designs for the Ultra37000 family in a matter of minutes. Finally, the rich routing resources of the Ultra37000 family accommodate last minute logic changes while maintaining fixed pin assignments.

Logic Block

The logic block is the basic building block of the Ultra37000 architecture. It consists of a product term array, an intelligent product-term allocator, 16 macrocells, and a number of I/O cells. The number of I/O cells varies depending on the device used. Refer to [Figure 7](#) for the block diagram.

Product Term Array

Each logic block features a 72 × 87 programmable product term array. This array accepts 36 inputs from the PIM, which originate from macrocell feedbacks and device pins. Active LOW and active HIGH versions of each of these inputs are generated to create the full 72-input field. The 87 product terms in the array can be created from any of the 72 inputs.

Of the 87 product terms, 80 are for general-purpose use for the 16 macrocells in the logic block. Four of the remaining seven product terms in the logic block are output enable (OE) product terms. Each of the OE product terms controls up to eight of the 16 macrocells and is selectable on an individual macrocell basis. In other words, each I/O cell can select between one of two OE product terms to control the output buffer. The first two of these four OE product terms are available to the upper half of the I/O macrocells in a logic block. The other two OE product terms are available to the lower half of the I/O macrocells in a logic block.

The next two product terms in each logic block are dedicated asynchronous set and asynchronous reset product terms. The final product term is the product term clock. The set, reset, OE and product term clock have polarity control to realize OR functions in a single pass through the array.

Figure 7. Logic Block with 50% Buried Macrocells

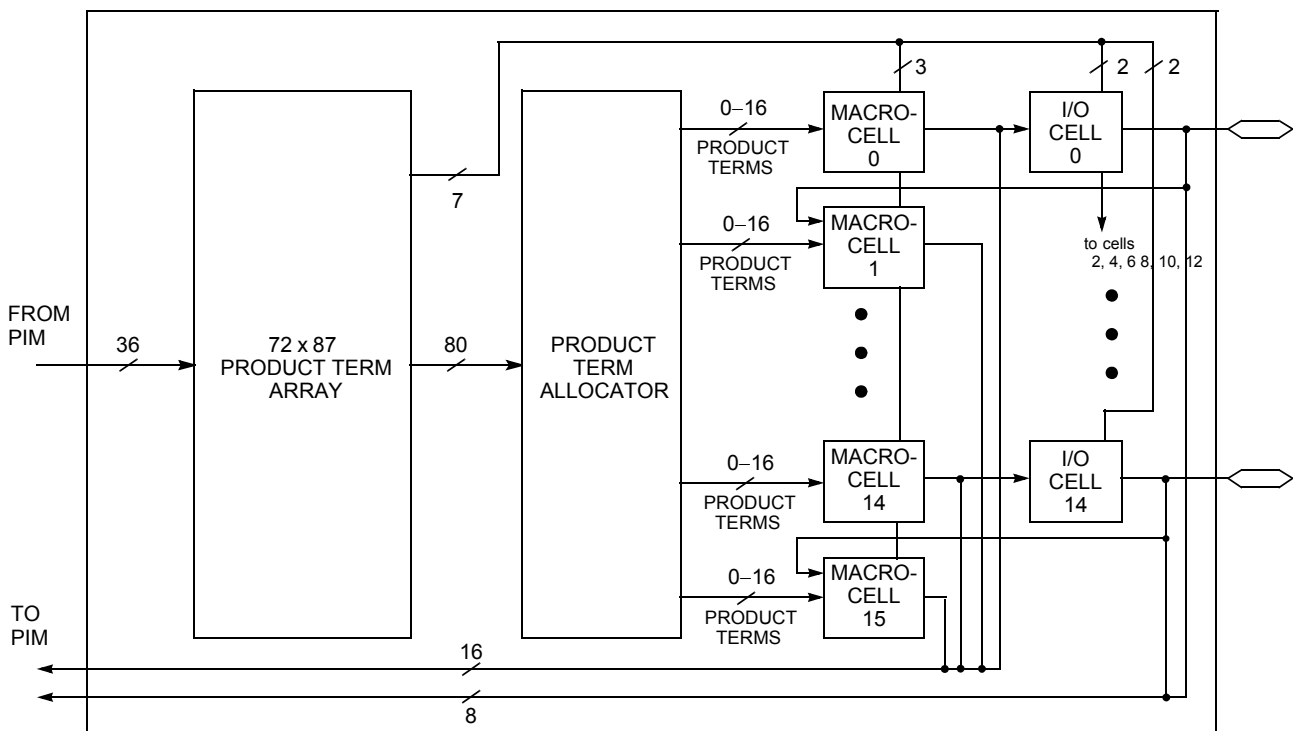

"Not Recommended for New Design"

Low Power Option

Each logic block can operate in high speed mode for critical path performance, or in low power mode for power conservation. The logic block mode is set by the user on a logic block by logic block basis.

Product Term Allocator

Through the product term allocator, software automatically distributes product terms among the 16 macrocells in the logic block as needed. A total of 80 product terms are available from the local product term array. The product term allocator provides two important capabilities without affecting performance: product term steering and product term sharing.

Product Term Steering

Product term steering is the process of assigning product terms to macrocells as needed. For example, if one macrocell requires ten product terms while another needs just three, the product term allocator will “steer” ten product terms to one macrocell and three to the other. On Ultra37000 devices, product terms are steered on an individual basis. Any number between 0 and 16 product terms can be steered to any macrocell. Note that 0 product terms is useful in cases where a particular macrocell is unused or used as an input register.

Product Term Sharing

Product term sharing is the process of using the same product term among multiple macrocells. For example, if more than one output has one or more product terms in its equation that are common to other outputs, those product terms are only programmed once. The Ultra37000 product term allocator allows sharing across groups of four output macrocells in a variable fashion. The software automatically takes advantage of this capability—the user does not have to intervene.

Note that neither product term sharing nor product term steering have any effect on the speed of the product. All worst-case steering and sharing configurations are incorporated in the timing specifications for the Ultra37000 devices.

Ultra37000 Macrocell

Within each logic block there are 16 macrocells. Macrocells can either be I/O Macrocells, which include an I/O Cell which is associated with an I/O pin, or buried Macrocells, which do not connect to an I/O. The combination of I/O Macrocells and buried Macrocells varies from device to device.

Buried Macrocell

Figure 8 displays the architecture of buried macrocells. The buried macrocell features a register that can be configured as combinatorial, a D flip-flop, a T flip-flop, or a level-triggered latch.

The register can be asynchronously set or asynchronously reset at the logic block level with the separate set and reset product terms. Each of these product terms features programmable polarity. This allows the registers to be set or reset based on an AND expression or an OR expression.

Clocking of the register is very flexible. Four global synchronous clocks and a product term clock are available to clock the register. Furthermore, each clock features programmable polarity so that registers can be triggered on falling and rising edges (see [Clocking on page 16](#)). Clock polarity is chosen at the logic block level.

The buried macrocell also supports input register capability. The buried macrocell can be configured to act as an input register (D-type or latch) whose input comes from the I/O pin associated with the neighboring macrocell. The output of all buried macrocells is sent directly to the PIM regardless of its configuration.

I/O Macrocell

Figure 8 on page 15 illustrates the architecture of the I/O macrocell. The I/O macrocell supports the same functions as the buried macrocell with the addition of I/O capability. At the output of the macrocell, a polarity control mux is available to select active LOW or active HIGH signals. This has the added advantage of allowing significant logic reduction to occur in many applications.

The Ultra37000 macrocell features a feedback path to the PIM separate from the I/O pin input path. This means that if the macrocell is buried (fed back internally only), the associated I/O pin can still be used as an input.

Bus Hold Capabilities on all I/Os

Bus-hold, which is an improved version of the popular internal pull-up resistor, is a weak latch connected to the pin that does not degrade the device's performance. As a latch, bus-hold maintains the last state of a pin when the pin is placed in a high impedance state, thus reducing system noise in bus-interface applications. Bus-hold additionally allows unused device pins to remain unconnected on the board, which is particularly useful during prototyping as designers can route new signals to the device without cutting trace connections to V_{CC} or GND. For more information, see the application note *Understanding Bus-Hold — A Feature of Cypress CPLDs*.

Programmable Slew Rate Control

Each output has a programmable configuration bit, which sets the output slew rate to fast or slow. For designs concerned with meeting FCC emissions standards the slow edge provides for lower system noise. For designs requiring very high performance the fast edge rate provides maximum system performance.

Figure 8. I/O and Buried Macrocells

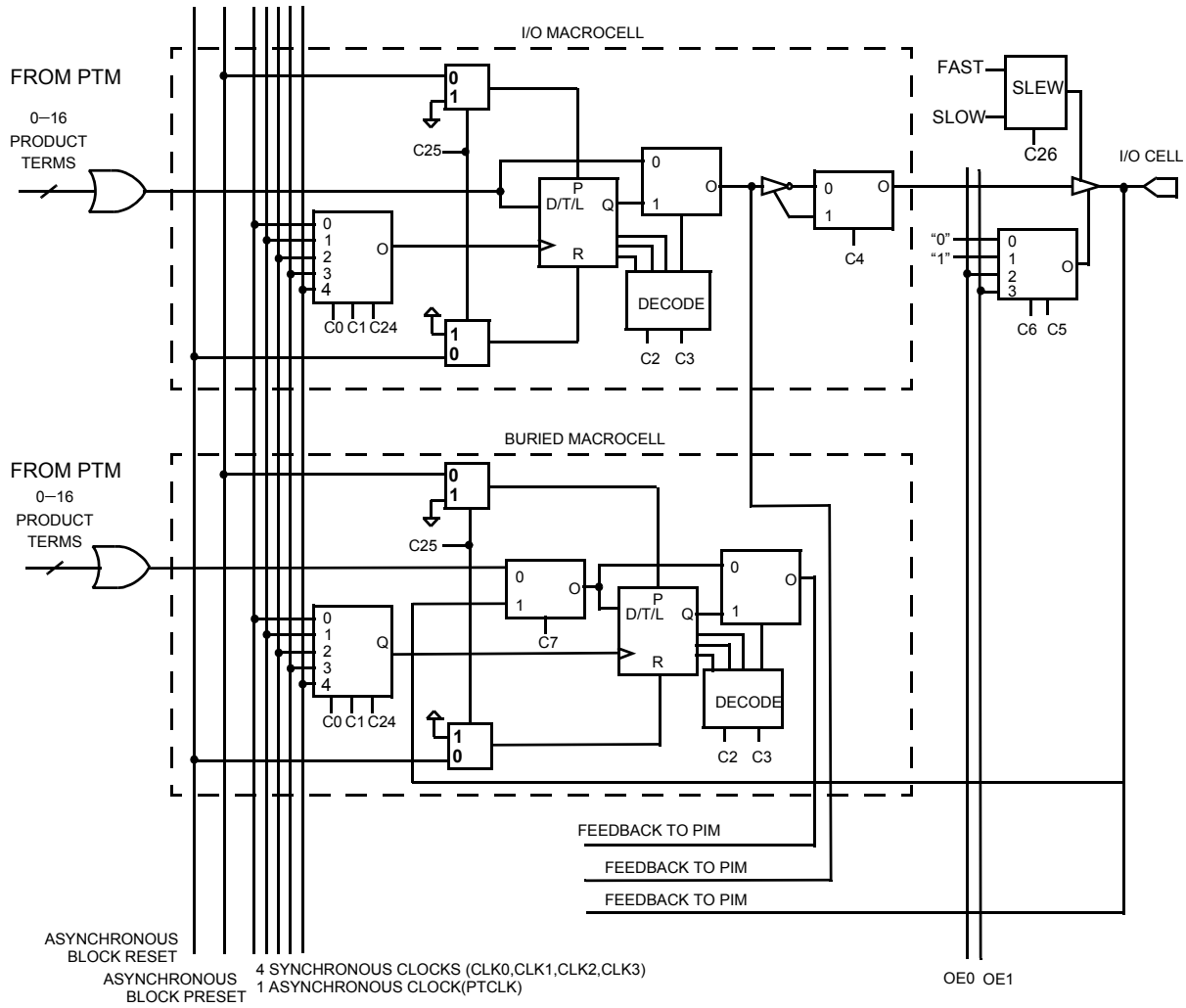

"Not Recommended for New Design"

Figure 9. Input Macrocell

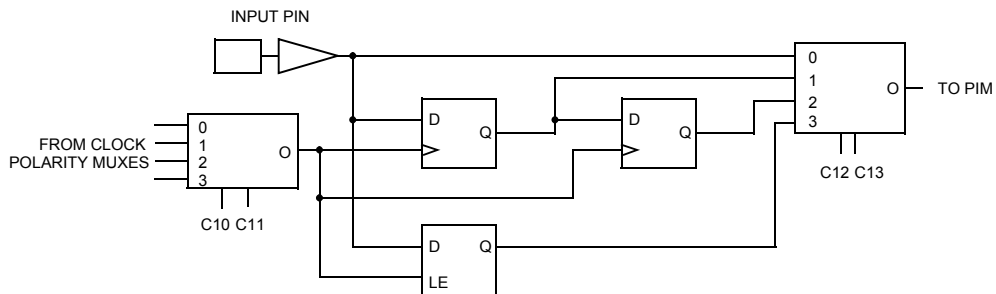
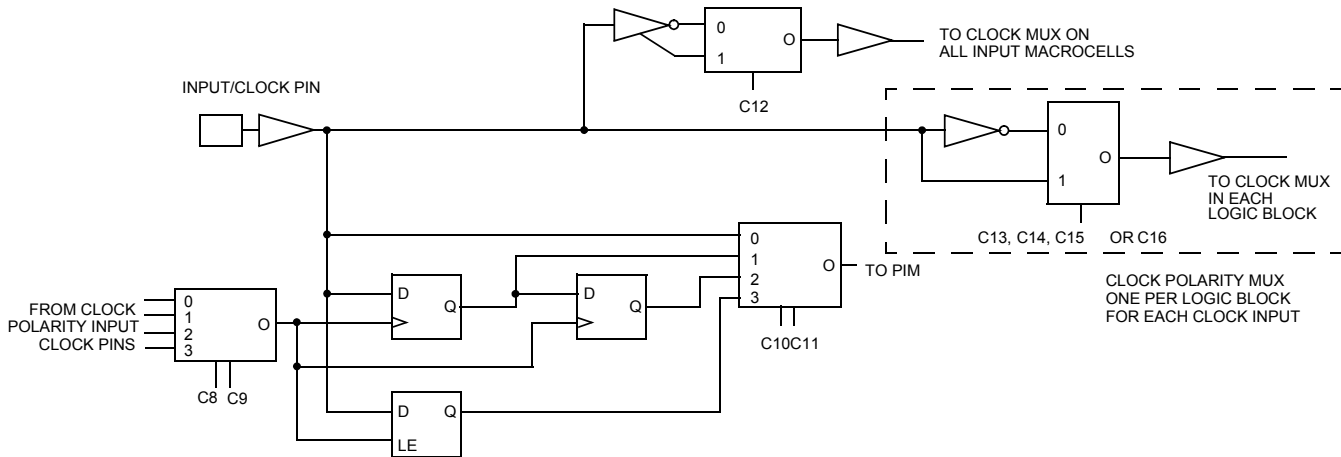

Figure 10. Input/Clock Macrocell



Clocking

Each I/O and buried macrocell has access to four synchronous clocks (CLK0, CLK1, CLK2 and CLK3) and an asynchronous product term clock PTCLK. Each input macrocell has access to all four synchronous clocks.

Dedicated Inputs/Clocks

Five pins on each member of the Ultra37000 family are designated as input-only. There are two types of dedicated inputs on Ultra37000 devices: input pins and input/clock pins. Figure 9 on page 15 illustrates the architecture for input pins. Four input options are available for the user: combinatorial, registered, double-registered, or latched. If a registered or latched option is selected, any one of the input clocks can be selected for control.

Figure 10 illustrates the architecture for the input/clock pins. Similar to the input pins, input/clock pins can be combinatorial, registered, double-registered, or latched. In addition, these pins feed the clocking structures throughout the device. The clock path at the input has user-configurable polarity.

Product Term Clocking

In addition to the four synchronous clocks, the Ultra37000 family also has a product term clock for asynchronous clocking. Each logic block has an independent product term clock which is available to all 16 macrocells. Each product term clock also supports user configurable polarity selection.

Timing Model

One of the most important features of the Ultra37000 family is the simplicity of its timing. All delays are worst case and system performance is unaffected by the features used. Figure 11 illustrates the true timing model for the 167-MHz devices in high speed mode. For combinatorial paths, any input to any output incurs a 6.5 ns worst-case delay regardless of the amount of logic used. For synchronous systems, the input setup time to the output macrocells for any input is 3.5 ns and the clock to output

time is also 4.0 ns. These measurements are for any output and synchronous clock, regardless of the logic used.

The Ultra37000 features:

- No fanout delays
- No expander delays
- No dedicated vs. I/O pin delays
- No additional delay through PIM
- No penalty for using 0–16 product terms
- No added delay for steering product terms
- No added delay for sharing product terms
- No routing delays
- No output bypass delays

The simple timing model of the Ultra37000 family eliminates unexpected performance penalties.

Figure 11. Timing Model for CY37128

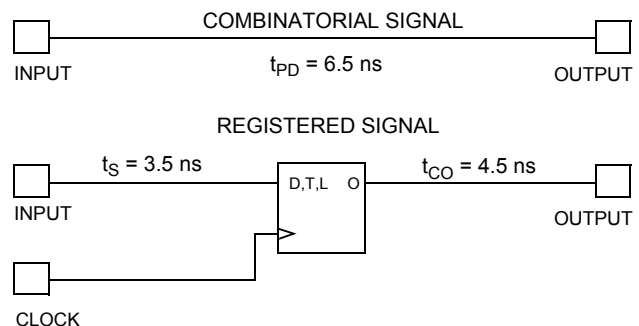

"Not Recommended for New Design"

JTAG and PCI Standards

PCI Compliance

5V operation of the Ultra37000 is fully compliant with the PCI Local Bus Specification published by the PCI Special Interest Group. The 3.3V products meet all PCI requirements except for the output 3.3V clamp, which is in direct conflict with 5V tolerance. The Ultra37000 family's simple and predictable timing model ensures compliance with the PCI AC specifications independent of the design.

IEEE 1149.1-compliant JTAG

The Ultra37000 family has an IEEE 1149.1 JTAG interface for both Boundary Scan and ISR.

Boundary Scan

The Ultra37000 family supports Bypass, Sample/Preload, Extest, Idcode, and Usercode boundary scan instructions. The JTAG interface is shown in Figure 12.

Figure 12. JTAG Interface

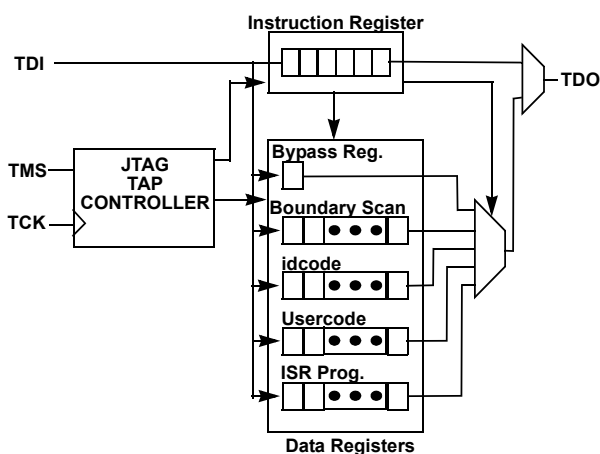

In-System Reprogramming (ISR)

In-System Reprogramming is the combination of the capability to program or reprogram a device on-board, and the ability to support design changes without changing the system timing or device pinout. This combination means design changes during debug or field upgrades do not cause board respins. The Ultra37000 family implements ISR by providing a JTAG compliant interface for on-board programming, robust routing resources for pinout flexibility, and a simple timing model for consistent system performance.

Development Software Support

Warp

Warp is a state-of-the-art compiler and complete CPLD design tool. For design entry, Warp provides an IEEE-STD-1076/1164 VHDL text editor, an IEEE-STD-1364 Verilog text editor, and a graphical finite state machine editor. It provides optimized synthesis and fitting by replacing basic circuits with ones pre-optimized for the target device, by implementing logic in unused memory and by perfect communication between fitting and synthesis. To facilitate design and debugging, Warp provides graphical timing simulation and analysis.

Warp Professional™

Warp Professional contains several additional features. It provides an extra method of design entry with its graphical block diagram editor. It allows up to 5 ms timing simulation instead of only 2 ms. It allows comparison of waveforms before and after design changes.

Warp Enterprise™

Warp Enterprise provides even more features. It provides unlimited timing simulation and source-level behavioral simulation as well as a debugger. It has the ability to generate graphical HDL blocks from HDL text. It can even generate testbenches.

Warp is available for PC and UNIX platforms. Some features are not available in the UNIX version. For further information see the Warp for PC, Warp for UNIX, Warp Professional and Warp Enterprise data sheets on Cypress's web site.

Third-Party Software

Although Warp is a complete CPLD development tool on its own, it interfaces with nearly every third party EDA tool. All major third-party software vendors provide support for the Ultra37000 family of devices. Refer to the third-party software data sheet or contact your local sales office for a list of currently supported third-party vendors.

Programming

There are four programming options available for Ultra37000 devices. The first method is to use a PC with the 37000 UltraISR programming cable and software. With this method, the ISR pins of the Ultra37000 devices are routed to a connector at the edge of the printed circuit board. The 37000 UltraISR programming cable is then connected between the parallel port of the PC and this connector. A simple configuration file instructs the ISR software of the programming operations to be performed on each of the Ultra37000 devices in the system. The ISR software then automatically completes all of the necessary data manipulations required to accomplish the programming, reading, verifying, and other ISR functions. For more information on the Cypress ISR Interface, see the CYUSBISRPC Programming Cable User's Guide.

"Not Recommended for New Design"

The second method for programming Ultra37000 devices is on automatic test equipment (ATE). This is accomplished through a file created by the ISR software. Check the Cypress website for the latest ISR software download information.

The third programming option for Ultra37000 devices is to utilize the embedded controller or processor that already exists in the system. The Ultra37000 ISR software assists in this method by converting the device JEDEC maps into the ISR serial stream that contains the ISR instruction information and the addresses and data of locations to be programmed. The embedded controller then simply directs this ISR stream to the chain of Ultra37000 devices to complete the desired reconfiguring or diagnostic operations. Contact your local sales office for information on availability of this option.

The fourth method for programming Ultra37000 devices is to use the same programmer that is currently being used to program FLASH370i devices.

For all pinout, electrical, and timing requirements, refer to device data sheets. For ISR cable and software specifications, refer to the UltraISR kit data sheet (CY3700i).

Third-Party Programmers

As with development software, Cypress support is available on a wide variety of third-party programmers. All major third-party programmers (including BP Micro, Data I/O, and SMS) support the Ultra37000 family.

5 V Device Maximum Ratings

Exceeding maximum ratings may shorten the useful life of the device. These user guidelines are not tested.

Storage Temperature	-65 °C to +150 °C
Ambient Temperature with Power Applied	-55 °C to +125 °C
Supply Voltage to Ground Potential	-0.5 V to +7.0 V

DC Voltage Applied to Outputs in High-Z State	-0.5 V to +7.0 V
DC Input Voltage	-0.5 V to +7.0 V
DC Program Voltage	4.5 to 5.5 V
Current into Outputs	16 mA
Static Discharge Voltage (per MIL-STD-883, Method 3015)	> 2001 V
Latch-up Current	> 200 mA

Operating Range

The Operating Range is described as follows. [4]

Range	Ambient Temperature [4]	Junction Temperature	Output Condition	V _{CC}	V _{CCO}
Commercial	0 °C to +70 °C	0 °C to +90 °C	5 V	5 V ± 0.25 V	5 V ± 0.25 V
			3.3 V	5 V ± 0.25 V	3.3 V ± 0.3 V
Industrial	-40 °C to +85 °C	-40 °C to +105 °C	5 V	5 V ± 0.5 V	5 V ± 0.5 V
			3.3 V	5 V ± 0.5 V	3.3 V ± 0.3 V

5 V Device Electrical Characteristics

Over the Operating Range

Parameter	Description	Test Conditions	Min	Typ	Max	Unit
V _{OH}	Output HIGH Voltage	V _{CC} = Min I _{OH} = -3.2 mA (Commercial / Industrial) [6] I _{OH} = -2.0 mA (Military) [6]	2.4	-	-	V
			2.4	-	-	V
V _{OHZ}	Output HIGH Voltage with Output Disabled [7]	V _{CC} = Max I _{OH} = 0 μA (Commercial) [8] I _{OH} = 0 μA (Industrial / Military) [8] I _{OH} = -100 μA (Commercial) [8] I _{OH} = -150 μA (Industrial / Military) [8]	-	-	4.2	V
			-	-	4.5	V
			-	-	3.6	V
			-	-	3.6	V
V _{OL}	Output LOW Voltage	V _{CC} = Min I _{OL} = 16 mA (Commercial / Industrial) [6] I _{OL} = 12 mA (Military) [6]	-	-	0.5	V
			-	-	0.5	V
V _{IH}	Input HIGH Voltage	Guaranteed Input Logical HIGH Voltage for all Inputs [9]	2.0	-	V _{CCmax}	V
V _{IL}	Input LOW Voltage	Guaranteed Input Logical LOW Voltage for all Inputs [9]	-0.5	-	0.8	V
I _{Ix}	Input Load Current	V _I = GND or V _{CC} , Bus-Hold Disabled	-10	-	10	μA
I _{OZ}	Output Leakage Current	V _O = GND or V _{CC} , Output Disabled, Bus-Hold Disabled	-50	-	50	μA
I _{OS}	Output Short Circuit Current [7, 10]	V _{CC} = Max, V _{OUT} = 0.5 V	-30	-	-160	mA

Notes

- Normal Programming Conditions apply across Ambient Temperature Range for specified programming methods. For more information on programming the Ultra37000 Family devices, refer to the Application Note titled *An Introduction to In System Reprogramming with the Ultra37000*.
- T_A is the "Instant On" case temperature.
- I_{OH} = -2 mA, I_{OL} = 2 mA for TDO.
- Tested initially and after any design or process changes that may affect these parameters.
- When the I/O is output disabled, the bus-hold circuit can weakly pull the I/O to above 3.6V if no leakage current is allowed. Note that all I/Os are output disabled during ISR programming. Refer to the application note "Understanding Bus-Hold" for additional information.
- These are absolute values with respect to device ground. All overshoots due to system or tester noise are included.
- Not more than one output should be tested at a time. Duration of the short circuit should not exceed 1 second. V_{OUT} = 0.5 V is chosen to avoid test problems caused

5 V Device Electrical Characteristics (continued)

Over the Operating Range

Parameter	Description	Test Conditions	Min	Typ	Max	Unit
I _{BHL}	Input Bus-Hold LOW Sustaining Current	V _{CC} = Min, V _{IL} = 0.8 V	+75	–	–	μA
I _{BHH}	Input Bus-Hold HIGH Sustaining Current	V _{CC} = Min, V _{IH} = 2.0 V	–75	–	–	μA
I _{BHLO}	Input Bus-Hold LOW Overdrive Current	V _{CC} = Max	–	–	+500	μA
I _{BHHO}	Input Bus-Hold HIGH Overdrive Current	V _{CC} = Max	–	–	–500	μA

Inductance

Parameter ^[11]	Description	Test Conditions	44-pin TQFP	44-pin PLCC	100-pin TQFP	160-pin TQFP	Unit
L	Maximum Pin Inductance	V _{IN} = 5 V at f = 1 MHz	2	5	8	9	nH

Capacitance

Parameter ^[11]	Description	Test Conditions	Max	Unit
C _{I/O}	Input/Output Capacitance	V _{IN} = 5 V at f = 1 MHz at T _A = 25 °C	10	pF
C _{CLK}	Clock Signal Capacitance	V _{IN} = 5 V at f = 1 MHz at T _A = 25 °C	12	pF
C _{D.P}	Dual-Function Pins ^[12]	V _{IN} = 5 V at f = 1 MHz at T _A = 25 °C	16	pF

Endurance Characteristics

Parameter ^[11]	Description	Test Conditions	Min	Typ	Unit
N	Minimum Reprogramming Cycles	Normal Programming Conditions ^[13]	1,000	10,000	Cycles

Notes

11. Tested initially and after any design or process changes that may affect these parameters.

12. Dual pins are I/O with JTAG pins.

13. Normal Programming Conditions apply across Ambient Temperature Range for specified programming methods. For more information on programming the Ultra37000 Family devices, refer to the Application Note titled *An Introduction to In System Reprogramming with the Ultra37000*.

3.3 V Device Maximum Ratings

Exceeding maximum ratings may shorten the useful life of the device. These user guidelines are not tested.

Storage Temperature	-65 °C to +150 °C
Ambient Temperature with Power Applied	-55 °C to +125 °C
Supply Voltage to Ground Potential	-0.5 V to +4.6 V

DC Voltage Applied to Outputs in High-Z State	-0.5 V to +7.0 V
DC Input Voltage	-0.5 V to +7.0 V
DC Program Voltage	3.0 to 3.6 V
Current into Outputs	8 mA
Static Discharge Voltage (per MIL-STD-883, Method 3015)	> 2001 V
Latch-up Current	> 200 mA

Operating Range

The Operating Range is described as follows. ^[14]

Range	Ambient Temperature ^[14]	Junction Temperature	V _{CC} ^[15]
Commercial	0 °C to +70 °C	0 °C to +90 °C	3.3 V ± 0.3 V
Industrial	-40 °C to +85 °C	-40 °C to +105 °C	3.3 V ± 0.3 V

3.3 V Device Electrical Characteristics

Over the Operating Range

Parameter	Description	Test Conditions	Min	Max	Unit
V _{OH}	Output HIGH Voltage	V _{CC} = Min I _{OH} = -4 mA (Commercial) ^[16] I _{OH} = -3 mA (Military) ^[16]	2.4	-	V
V _{OL}	Output LOW Voltage	V _{CC} = Min I _{OL} = 8 mA (Commercial) ^[16] I _{OL} = 6 mA (Military) ^[16]	-	0.5	V
V _{IH}	Input HIGH Voltage	Guaranteed Input Logical HIGH Voltage for all Inputs ^[17]	2.0	5.5	V
V _{IL}	Input LOW Voltage	Guaranteed Input Logical LOW Voltage for all Inputs ^[17]	-0.5	0.8	V
I _{IX}	Input Load Current	V _I = GND or V _{CC} , Bus-Hold Disabled	-10	10	μA
I _{OZ}	Output Leakage Current	V _O = GND or V _{CC} , Output Disabled, Bus-Hold Disabled	-50	50	μA
I _{OS}	Output Short Circuit Current ^[18, 19]	V _{CC} = Max, V _{OUT} = 0.5 V	-30	-160	mA
I _{BHL}	Input Bus-Hold LOW Sustaining Current	V _{CC} = Min, V _{IL} = 0.8 V	+75	-	μA
I _{BHH}	Input Bus-Hold HIGH Sustaining Current	V _{CC} = Min, V _{IH} = 2.0 V	-75	-	μA
I _{BHLO}	Input Bus-Hold LOW Overdrive Current	V _{CC} = Max	-	+500	μA
I _{BHHO}	Input Bus-Hold HIGH Overdrive Current	V _{CC} = Max	-	-500	μA

Notes

- Normal Programming Conditions apply across Ambient Temperature Range for specified programming methods. For more information on programming the Ultra37000 Family devices, refer to the Application Note titled *An Introduction to In System Reprogramming with the Ultra37000*.
- For CY37064VP100-143AXC, CY37064VP44-143AXC; Operating Range: V_{CC} is 3.3 V ± 0.16 V.
- I_{OH} = -2 mA, I_{OL} = 2 mA for TDO.
- These are absolute values with respect to device ground. All overshoots due to system or tester noise are included.
- Tested initially and after any design or process changes that may affect these parameters.
- Not more than one output should be tested at a time. Duration of the short circuit should not exceed 1 second. V_{OUT} = 0.5 V is chosen to avoid test problems caused

Inductance

Parameter ^[20]	Description	Test Conditions	44- pin TQFP	44-pin PLCC	100- pin TQFP	160-pin TQFP	Unit
L	Maximum Pin Inductance	$V_{IN} = 3.3 \text{ V}$ at $f = 1 \text{ MHz}$	2	5	8	9	nH

Capacitance

Parameter ^[20]	Description	Test Conditions	Max	Unit
$C_{I/O}$	Input/Output Capacitance	$V_{IN} = 3.3 \text{ V}$ at $f = 1 \text{ MHz}$ at $T_A = 25 \text{ }^\circ\text{C}$	8	pF
C_{CLK}	Clock Signal Capacitance	$V_{IN} = 3.3 \text{ V}$ at $f = 1 \text{ MHz}$ at $T_A = 25 \text{ }^\circ\text{C}$	12	pF
C_{DP}	Dual Functional Pins ^[21]	$V_{IN} = 3.3 \text{ V}$ at $f = 1 \text{ MHz}$ at $T_A = 25 \text{ }^\circ\text{C}$	16	pF

Endurance Characteristics

Parameter ^[20]	Description	Test Conditions	Min	Typ	Unit
N	Minimum Reprogramming Cycles	Normal Programming Conditions ^[22]	1,000	10,000	Cycles

Notes

20. Tested initially and after any design or process changes that may affect these parameters.

21. Dual pins are I/O with JTAG pins.

22. Normal Programming Conditions apply across Ambient Temperature Range for specified programming methods. For more information on programming the Ultra37000 Family devices, refer to the Application Note titled *An Introduction to In System Reprogramming with the Ultra37000*.

AC Test Loads and Waveforms

Figure 13. 5 V AC Test Loads and Waveforms

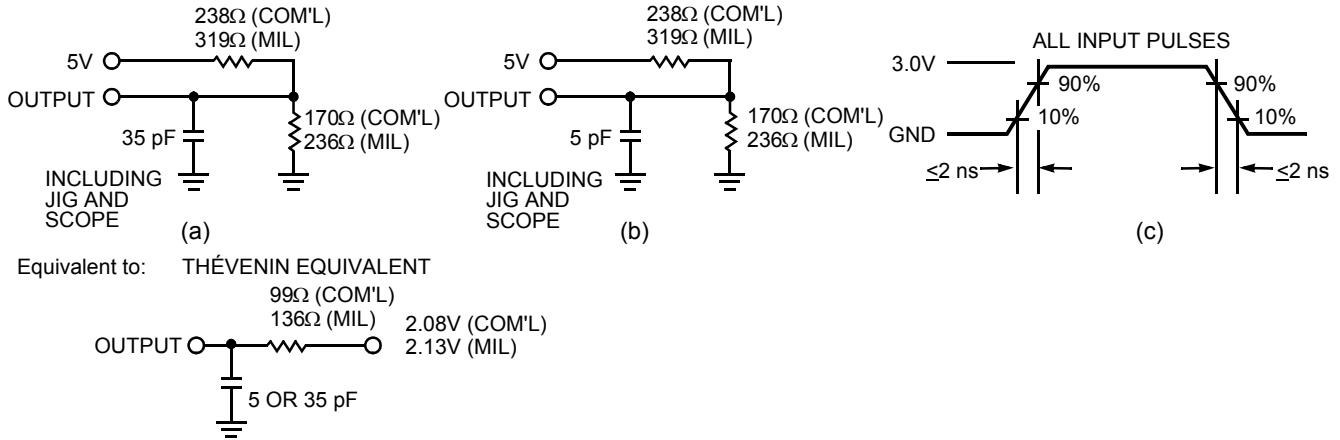
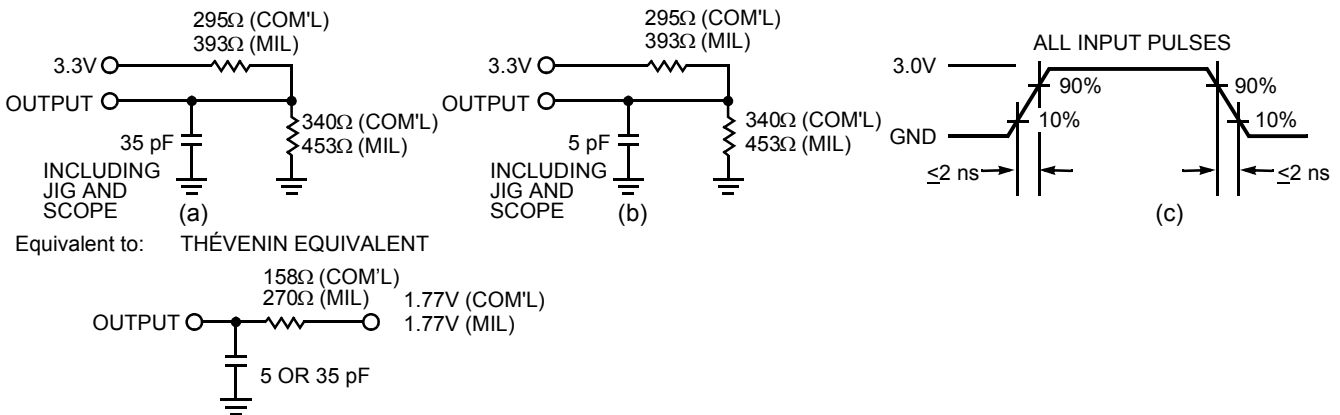
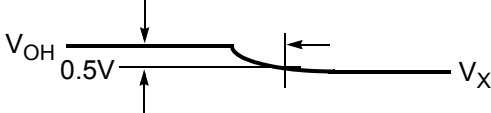
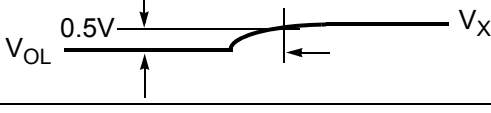
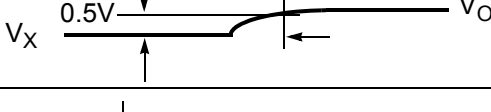
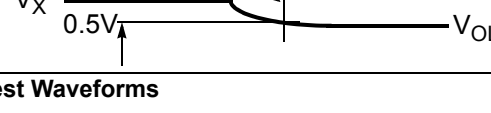

Figure 14. 3.3 V AC Test Loads and Waveforms



"Not Recommended for New Design"

Parameter ^[23]	V_X	Output Waveform — Measurement Level
$t_{ER(-)}$	1.5 V	
$t_{ER(+)}$	2.6 V	
$t_{EA(+)}$	1.5 V	
$t_{EA(-)}$	V_{the}	

(d) Test Waveforms

"Not Recommended for New Design"

Note

23. t_{ER} measured with 5 pF AC Test Load and t_{EA} measured with 35 pF AC Test Load.

Switching Characteristics

Over the Operating Range

Parameter ^[24]	Description	Unit
Combinatorial Mode Parameters		
$t_{PD}^{[25, 26, 27]}$	Input to Combinatorial Output	ns
$t_{PDL}^{[25, 26, 27]}$	Input to Output Through Transparent Input or Output Latch	ns
$t_{PDLL}^{[25, 26, 27]}$	Input to Output Through Transparent Input and Output Latches	ns
$t_{EA}^{[25, 26, 27]}$	Input to Output Enable	ns
$t_{ER}^{[25, 28]}$	Input to Output Disable	ns
Input Register Parameters		
t_{WL}	Clock or Latch Enable Input LOW Time ^[10]	ns
t_{WH}	Clock or Latch Enable Input HIGH Time ^[10]	ns
t_{IS}	Input Register or Latch Set-up Time	ns
t_{IH}	Input Register or Latch Hold Time	ns
$t_{ICO}^{[25, 26, 27]}$	Input Register Clock or Latch Enable to Combinatorial Output	ns
$t_{ICOL}^{[25, 26, 27]}$	Input Register Clock or Latch Enable to Output Through Transparent Output Latch	ns
Synchronous Clocking Parameters		
$t_{CO}^{[26, 27]}$	Synchronous Clock (CLK ₀ , CLK ₁ , CLK ₂ , or CLK ₃) or Latch Enable to Output	ns
$t_S^{[25]}$	Set-Up Time from Input to Sync. Clk (CLK ₀ , CLK ₁ , CLK ₂ , or CLK ₃) or Latch Enable	ns
t_H	Register or Latch Data Hold Time	ns
$t_{CO2}^{[25, 26, 27]}$	Output Synchronous Clock (CLK ₀ , CLK ₁ , CLK ₂ , or CLK ₃) or Latch Enable to Combinatorial Output Delay (Through Logic Array)	ns
$t_{SCS}^{[25]}$	Output Synchronous Clock (CLK ₀ , CLK ₁ , CLK ₂ , or CLK ₃) or Latch Enable to Output Synchronous Clock (CLK ₀ , CLK ₁ , CLK ₂ , or CLK ₃) or Latch Enable (Through Logic Array)	ns
$t_{SL}^{[25]}$	Set-Up Time from Input Through Transparent Latch to Output Register Synchronous Clock (CLK ₀ , CLK ₁ , CLK ₂ , or CLK ₃) or Latch Enable	ns
t_{HL}	Hold Time for Input Through Transparent Latch from Output Register Synchronous Clock (CLK ₀ , CLK ₁ , CLK ₂ , or CLK ₃) or Latch Enable	ns

"Not Recommended for New Design"

Notes

- 24. All AC parameters are measured with two outputs switching and 35 pF AC Test Load.
- 25. Logic blocks operating in low power mode, add t_{LP} to this specification.
- 26. Outputs using Slow Output Slew Rate, add t_{SLEW} to this specification.
- 27. When $V_{CC0} = 3.3V$, add $t_{3.3IO}$ to this specification.
- 28. t_{ER} measured with 5 pF AC Test Load and t_{EA} measured with 35 pF AC Test Load.

Switching Characteristics (continued)

Over the Operating Range

Parameter ^[24]	Description	Unit
Product Term Clocking Parameters		
$t_{COPT}^{[30, 31, 32]}$	Product Term Clock or Latch Enable (PTCLK) to Output	ns
t_{SPT}	Set-Up Time from Input to Product Term Clock or Latch Enable (PTCLK)	ns
t_{HPT}	Register or Latch Data Hold Time	ns
$t_{ISPT}^{[30]}$	Set-Up Time for Buried Register used as an Input Register from Input to Product Term Clock or Latch Enable (PTCLK)	ns
t_{IHPT}	Buried Register Used as an Input Register or Latch Data Hold Time	ns
$t_{CO2PT}^{[30, 31, 32]}$	Product Term Clock or Latch Enable (PTCLK) to Output Delay (Through Logic Array)	ns
Pipelined Mode Parameters		
$t_{ICS}^{[30]}$	Input Register Synchronous Clock (CLK ₀ , CLK ₁ , CLK ₂ , or CLK ₃) to Output Register Synchronous Clock (CLK ₀ , CLK ₁ , CLK ₂ , or CLK ₃)	ns
Operating Frequency Parameters		
f_{MAX1}	Maximum Frequency with Internal Feedback (Lesser of $1/t_{SCS}$, $1/(t_S + t_H)$, or $1/t_{CO}$) ^[33]	MHz
f_{MAX2}	Maximum Frequency Data Path in Output Registered/Latched Mode (Lesser of $1/(t_{WL} + t_{WH})$, $1/(t_S + t_H)$, or $1/t_{CO}$) ^[33]	MHz
f_{MAX3}	Maximum Frequency with External Feedback (Lesser of $1/(t_{CO} + t_S)$ or $1/(t_{WL} + t_{WH})$) ^[33]	MHz
f_{MAX4}	Maximum Frequency in Pipelined Mode (Lesser of $1/(t_{CO} + t_{IS})$, $1/t_{ICS}$, $1/(t_{WL} + t_{WH})$, $1/(t_{IS} + t_{IH})$, or $1/t_{SCS}$) ^[33]	MHz
Reset/Preset Parameters		
t_{RW}	Asynchronous Reset Width ^[33]	ns
$t_{RR}^{[30]}$	Asynchronous Reset Recovery Time ^[33]	ns
$t_{RO}^{[30, 31, 32]}$	Asynchronous Reset to Output	ns
t_{PW}	Asynchronous Preset Width ^[33]	ns
$t_{PR}^{[30]}$	Asynchronous Preset Recovery Time ^[33]	ns
$t_{PO}^{[30, 31, 32]}$	Asynchronous Preset to Output	ns
User Option Parameters		
t_{LP}	Low Power Adder	ns
t_{SLEW}	Slow Output Slew Rate Adder	ns
$t_{3.3IO}$	3.3 V I/O Mode Timing Adder ^[33]	ns
JTAG Timing Parameters		
$t_{S JTAG}$	Set-up Time from TDI and TMS to TCK ^[33]	ns
$t_{H JTAG}$	Hold Time on TDI and TMS ^[33]	ns
$t_{CO JTAG}$	Falling Edge of TCK to TDO ^[33]	ns
f_{JTAG}	Maximum JTAG Tap Controller Frequency ^[33]	ns

Notes

- 29. All AC parameters are measured with two outputs switching and 35 pF AC Test Load.
- 30. Logic blocks operating in low power mode, add t_{LP} to this specification.
- 31. Outputs using Slow Output Slew Rate, add t_{SLEW} to this specification.
- 32. When $V_{CC0} = 3.3V$, add $t_{3.3IO}$ to this specification.
- 33. Tested initially and after any design or process changes that may affect these parameters.

"Not Recommended for New Design"



Switching Characteristics

Over the Operating Range

Parameter ^[34]	200 MHz		167 MHz		154 MHz		143 MHz		125 MHz		100 MHz		83 MHz	
	Min	Max	Min	Max	Min	Max	Min	Max	Min	Max	Min	Max	Min	Max
Combinatorial Mode Parameters														
t_{PD} ^[35, 36, 37]	–	6	–	6.5	–	7.5	–	8.5	–	10	–	12	–	15
t_{PDL} ^[35, 36, 37]	–	11	–	12.5	–	14.5	–	16	–	16.5	–	17	–	19
t_{PDLL} ^[35, 36, 37]	–	12	–	13.5	–	15.5	–	17	–	17.5	–	18	–	20
t_{EA} ^[35, 36, 37]	–	8	–	8.5	–	11	–	13	–	14	–	16	–	19
t_{ER} ^[35, 38]	–	8	–	8.5	–	11	–	13	–	14	–	16	–	19
Input Register Parameters														
t_{WL}	2.5	–	2.5	–	2.5	–	2.5	–	3	–	3	–	4	–
t_{WH}	2.5	–	2.5	–	2.5	–	2.5	–	3	–	3	–	4	–
t_{IS}	2	–	2	–	2	–	2	–	2	–	2.5	–	3	–
t_{IH}	2	–	2	–	2	–	2	–	2	–	2.5	–	3	–
t_{ICO} ^[35, 36, 37]	–	11	–	11	–	11	–	12.5	–	12.5	–	16	–	19
t_{ICOL} ^[35, 36, 37]	–	12	–	12	–	12	–	14	–	16	–	18	–	21
Synchronous Clocking Parameters														
t_{CO} ^[36, 37]	–	4	–	4	–	4.5	–	6	–	6.5 ^[39]	–	6.5 ^[40]	–	8 ^[41]
t_S ^[35]	4	–	4	–	5	–	5	–	5.5 ^[39]	–	6 ^[40]	–	8 ^[41]	–
t_H	0	–	0	–	0	–	0	–	0	–	0	–	0	–
t_{CO2} ^[35, 36, 37]	–	9.5	–	10	–	11	–	12	–	14	–	16	–	19
t_{SCS} ^[35]	5	–	6	–	6.5	–	7	–	8 ^[39]	–	10	–	12	–
t_{SL} ^[35]	7.5	–	7.5	–	8.5	–	9	–	10	–	12	–	15	–
t_{HL}	0	–	0	–	0	–	0	–	0	–	0	–	0	–

Notes

- 34. All AC parameters are measured with two outputs switching and 35 pF AC Test Load.
- 35. Logic blocks operating in low power mode, add t_{LP} to this specification.
- 36. Outputs using Slow Output Slew Rate, add t_{SLEW} to this specification.
- 37. When $V_{CCO} = 3.3V$, add $t_{3.3IO}$ to this specification.
- 38. t_{ER} measured with 5 pF AC Test Load and t_{EA} measured with 35 pF AC Test Load.
- 39. For reference only, the following values correspond to the obsolete CY37512 devices: $t_{CO} = 5$ ns, $t_S = 6.5$ ns, $t_{SCS} = 8.5$ ns, $t_{IC} = 8.5$ ns, $f_{MAX1} = 118$ MHz.
- 40. The following values correspond to the CY37192V and CY37256V devices: $t_{CO} = 6$ ns, $t_S = 7$ ns, $f_{MAX2} = 143$ MHz, $f_{MAX3} = 77$ MHz, and $f_{MAX4} = 100$ MHz; and for the CY37512V devices: $t_{CO} = 6.5$ ns, $t_S = 9.5$ ns, and $f_{MAX2} = 105$ MHz.
- 41. For reference only, the following values correspond to the obsolete CY37512V devices: $t_{CO} = 6.5$ ns, $t_S = 9.5$ ns, and $f_{MAX2} = 105$ MHz.



Switching Characteristics (continued)

Over the Operating Range

Parameter ^[34]	200 MHz		167 MHz		154 MHz		143 MHz		125 MHz		100 MHz		83 MHz	
	Min	Max	Min	Max	Min	Max	Min	Max	Min	Max	Min	Max	Min	Max
Product Term Clocking Parameters														
t_{COPT} ^[42, 43, 44]	–	7	–	10	–	10	–	13	–	13	–	13	–	15
t_{SPT}	2.5	–	2.5	–	2.5	–	3	–	5	–	5.5	–	6	–
t_{HPT}	2.5	–	2.5	–	2.5	–	3	–	5	–	5.5	–	6	–
t_{ISPT} ^[42]	0	–	0	–	0	–	0	–	0	–	0	–	0	–
t_{IHPT}	6	–	6.5	–	6.5	–	7.5	–	9	–	11	–	14	–
t_{CO2PT} ^[42, 43, 44]	–	12	–	14	–	15	–	19	–	19	–	21	–	24
Pipelined Mode Parameters														
t_{ICS} ^[42]	5	–	6	–	6	–	7	–	8 ^[45]	–	10	–	12	–
Operating Frequency Parameters														
f_{MAX1}	200	–	167	–	154	–	143	–	125 ^[45]	–	100	–	83	–
f_{MAX2}	200	–	200	–	200	–	167	–	154	–	153 ^[46]	–	125 ^[47]	–
f_{MAX3}	125	–	125	–	105	–	91	–	83	–	80 ^[46]	–	62.5	–
f_{MAX4}	167	–	167	–	154	–	125	–	118	–	100	–	83	–
Reset/Preset Parameters														
t_{RW}	8	–	8	–	8	–	8	–	10	–	12	–	15	–
t_{RR} ^[42]	10	–	10	–	10	–	10	–	12	–	14	–	17	–

Notes

42. Logic blocks operating in low power mode, add t_{LP} to this specification.

43. Outputs using Slow Output Slew Rate, add t_{SLEW} to this specification.

44. When $V_{CC0} = 3.3V$, add $t_{3,3IO}$ to this specification.

45. For reference only, the following values correspond to the obsolete CY37512 devices: $t_{CO} = 5$ ns, $t_S = 6.5$ ns, $t_{SCS} = 8.5$ ns, $t_{CS} = 8.5$ ns, $f_{MAX1} = 118$ MHz.

46. The following values correspond to the CY37192V and CY37256V devices: $t_{CO} = 6$ ns, $t_S = 7$ ns, $f_{MAX2} = 143$ MHz, $f_{MAX3} = 77$ MHz, and $f_{MAX4} = 100$ MHz; and for the CY37512V devices: $t_{CO} = 6.5$ ns, $t_S = 9.5$ ns, and $f_{MAX2} = 105$ MHz.

47. For reference only, the following values correspond to the obsolete CY37512V devices: $t_{CO} = 6.5$ ns, $t_S = 9.5$ ns, and $f_{MAX2} = 105$ MHz.



Switching Characteristics (continued)

Over the Operating Range

Parameter ^[34]	200 MHz		167 MHz		154 MHz		143 MHz		125 MHz		100 MHz		83 MHz	
	Min	Max	Min	Max	Min	Max	Min	Max	Min	Max	Min	Max	Min	Max
t_{RO} ^[48, 49, 50]	–	12	–	13	–	13	–	14	–	15	–	18	–	21
t_{PW}	8	–	8	–	8	–	8	–	10	–	12	–	15	–
t_{PR} ^[48]	10	–	10	–	10	–	10	–	12	–	14	–	17	–
t_{PO} ^[48, 49, 50]	–	12	–	13	–	13	–	14	–	15	–	18	–	21
User Option Parameters														
t_{LP}	–	2.5	–	2.5	–	2.5	–	2.5	–	2.5	–	2.5	–	2.5
t_{SLEW}	–	3	–	3	–	3	–	3	–	3	–	3	–	3
$t_{3.3IO}$ ^[51]	–	0.3	–	0.3	–	0.3	–	0.3	–	0.3	–	0.3	–	0.3
JTAG Timing Parameters														
$t_{S\ JTAG}$	0	–	0	–	0	–	0	–	0	–	0	–	0	–
$t_{H\ JTAG}$	20	–	20	–	20	–	20	–	20	–	20	–	20	–
$t_{CO\ JTAG}$	–	20	–	20	–	20	–	20	–	20	–	20	–	20
f_{JTAG}	–	20	–	20	–	20	–	20	–	20	–	20	–	20

Notes

- 48. Logic blocks operating in low power mode, add t_{LP} to this specification.
- 49. Outputs using Slow Output Slew Rate, add t_{SLEW} to this specification.
- 50. When $V_{CC0} = 3.3V$, add $t_{3.3IO}$ to this specification.
- 51. Only applicable to the 5 V devices.

Switching Waveforms

Figure 15. Combinatorial Output

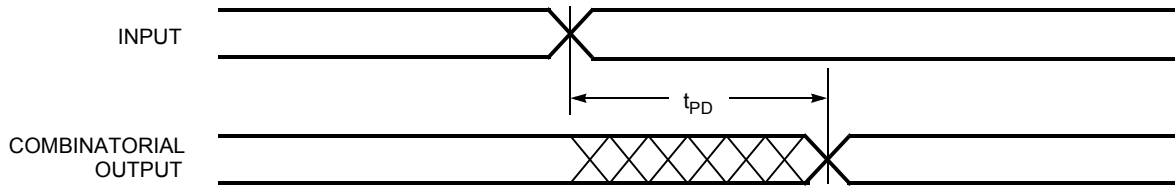

Figure 16. Registered Output with Synchronous Clocking

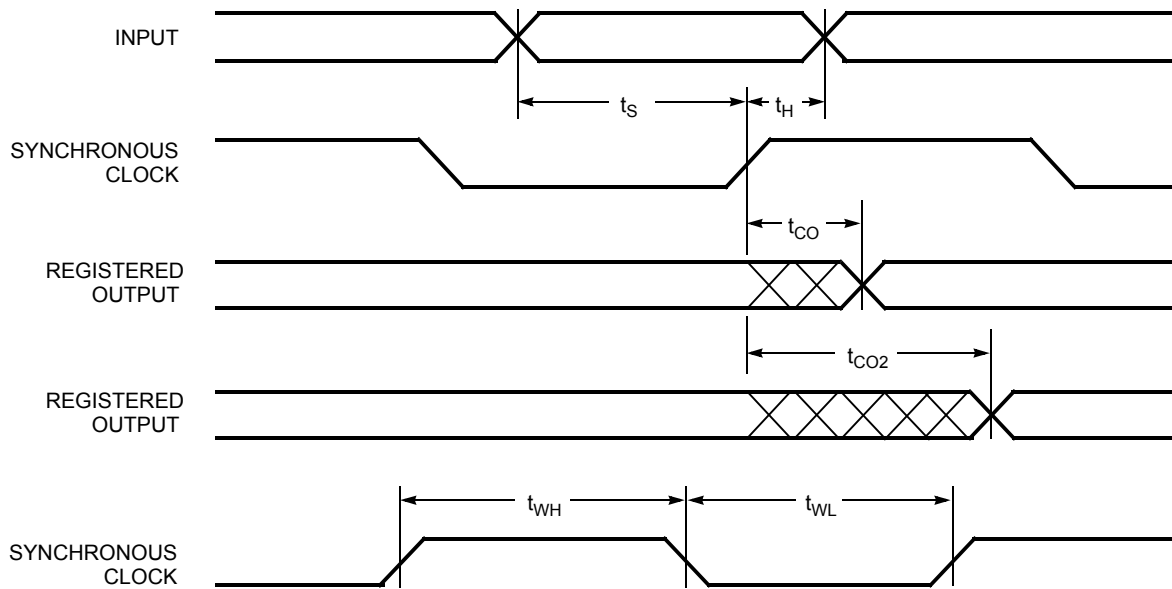
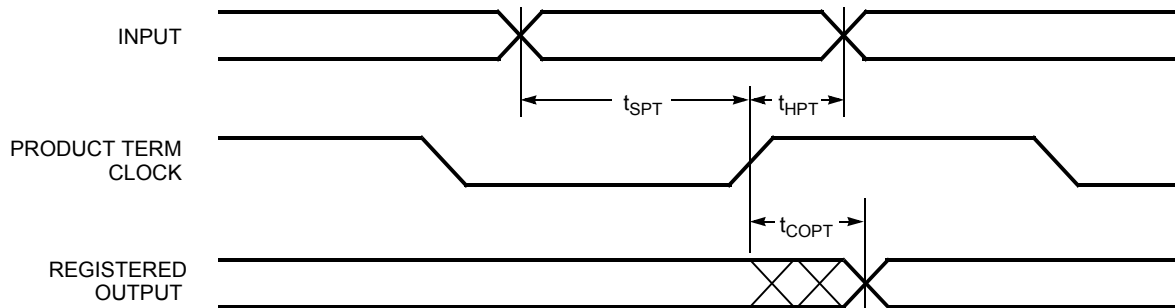

Figure 17. Registered Output with Product Term Clocking Input Going Through the Array



"Not Recommended for New Design"

Switching Waveforms (continued)

Figure 18. Registered Output with Product Term Clocking Input Coming From Adjacent Buried Register

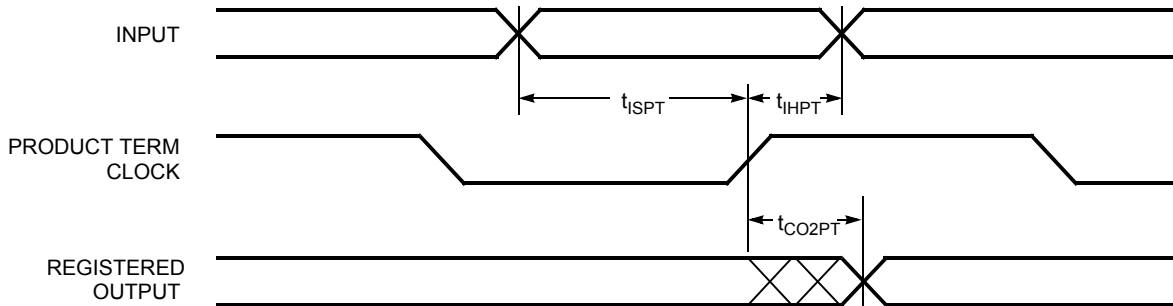

Figure 19. Latched Output

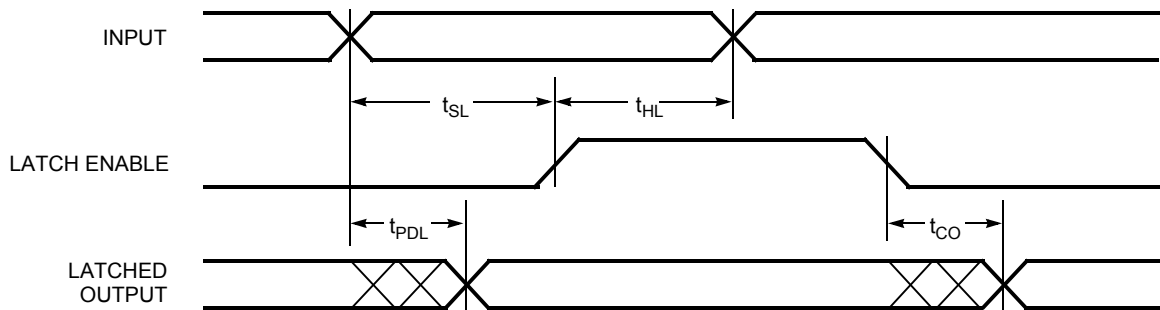

Figure 20. Registered Input

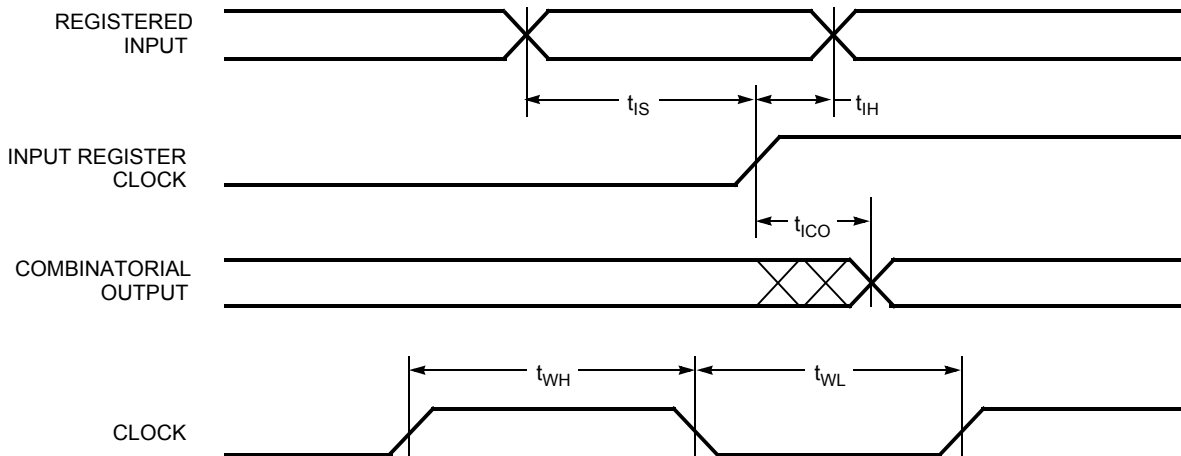
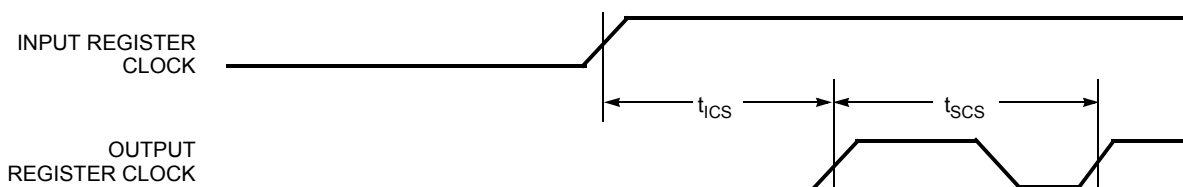

Figure 21. Clock to Clock



"Not Recommended for New Design"

Switching Waveforms (continued)

Figure 22. Latched Input

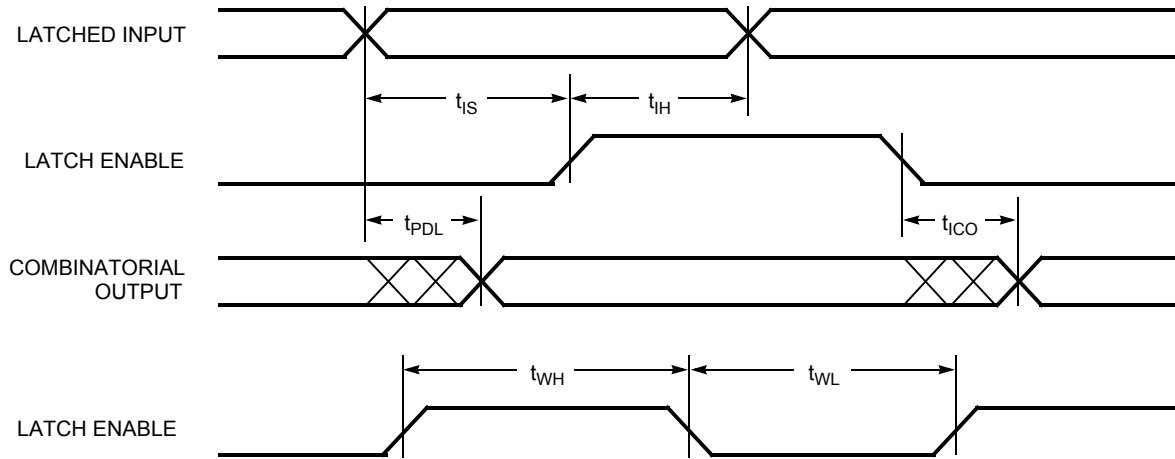

Figure 23. Latched Input and Output

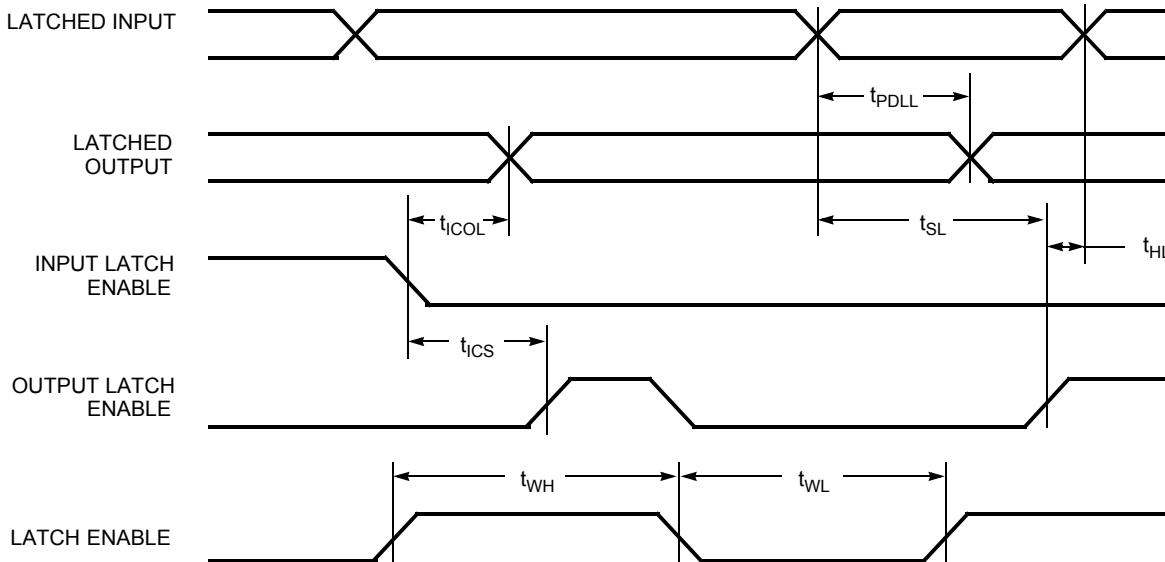
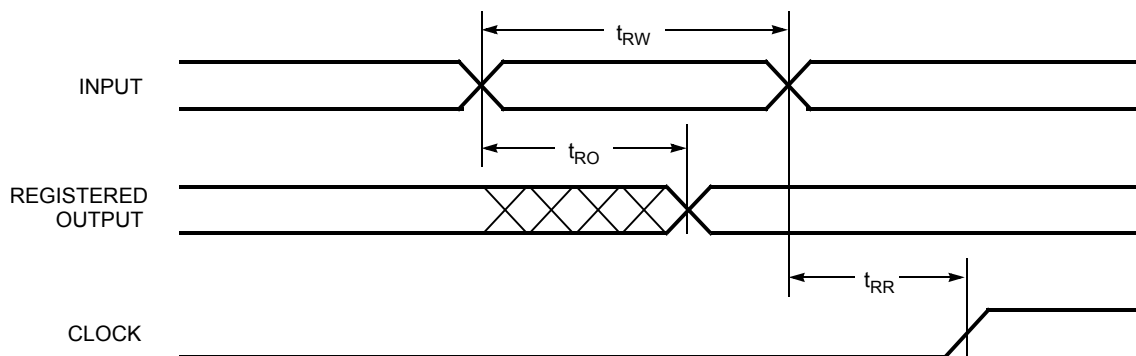

Figure 24. Asynchronous Reset



"Not Recommended for New Design"

Switching Waveforms (continued)

Figure 25. Asynchronous Preset

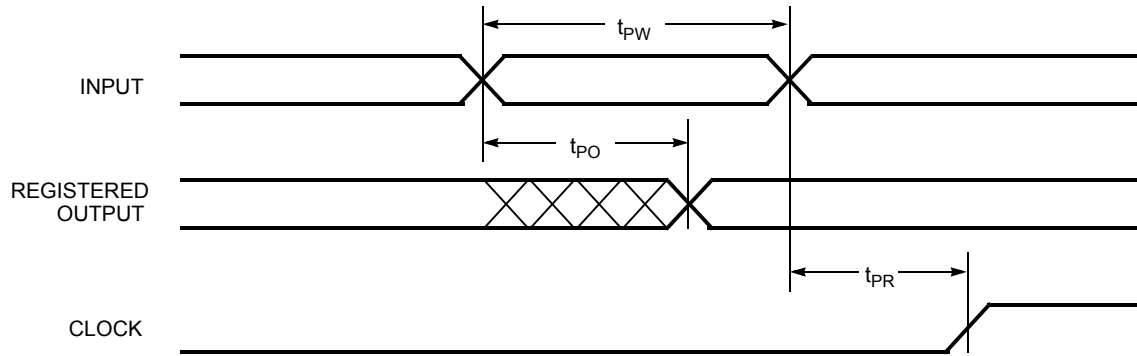
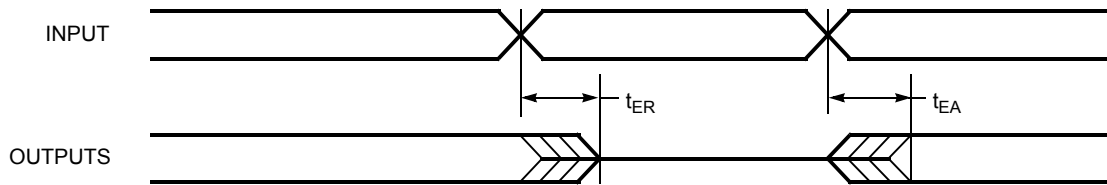

Figure 26. Output Enable/Disable



"Not Recommended for New Design"

Power Consumption

Typical 5 V Power Consumption CY37032

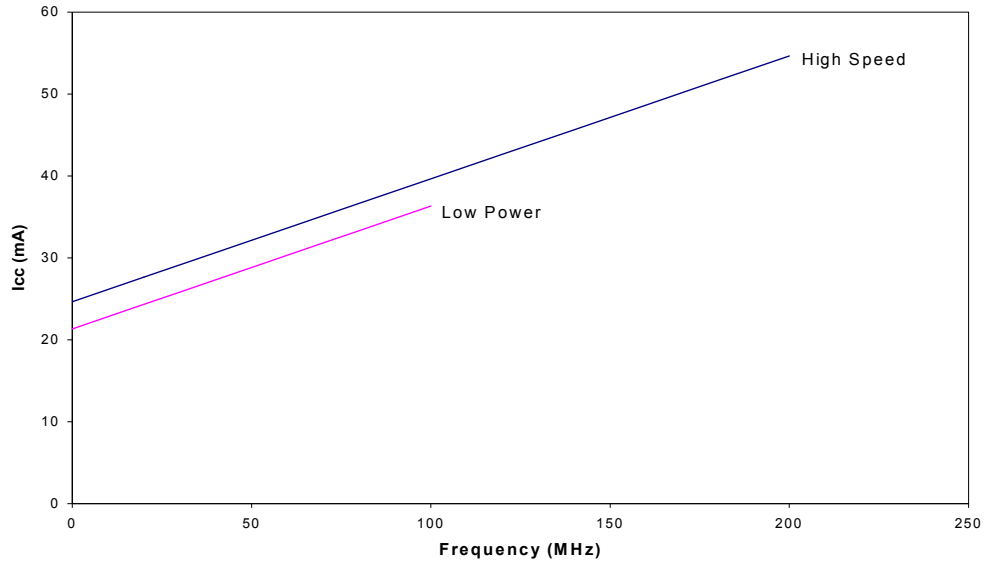

The typical pattern is a 16-bit up counter, per logic block, with outputs disabled.
 $V_{CC} = 5V$, $T_A = \text{Room Temperature}$

CY37064

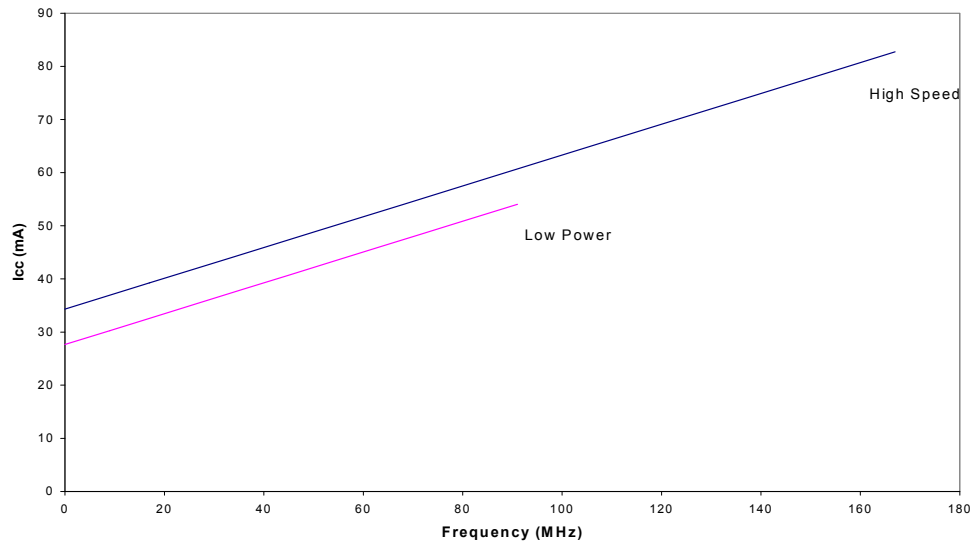

The typical pattern is a 16-bit up counter, per logic block, with outputs disabled.
 $V_{CC} = 5V$, $T_A = \text{Room Temperature}$

"Not Recommended for New Design"

Typical 5 V Power Consumption (continued) CY37128

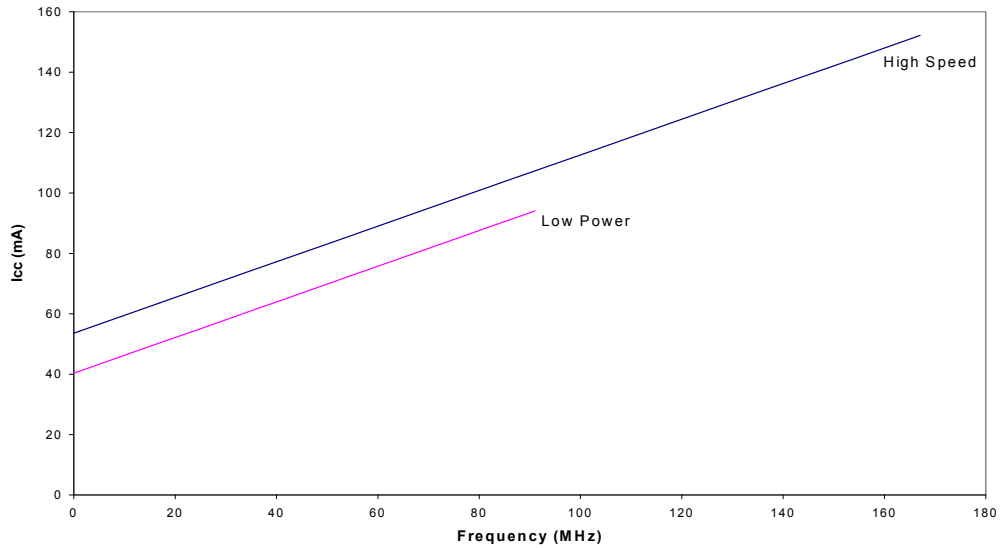

The typical pattern is a 16-bit up counter, per logic block, with outputs disabled.
 $V_{CC} = 5V$, $T_A = \text{Room Temperature}$

CY37192

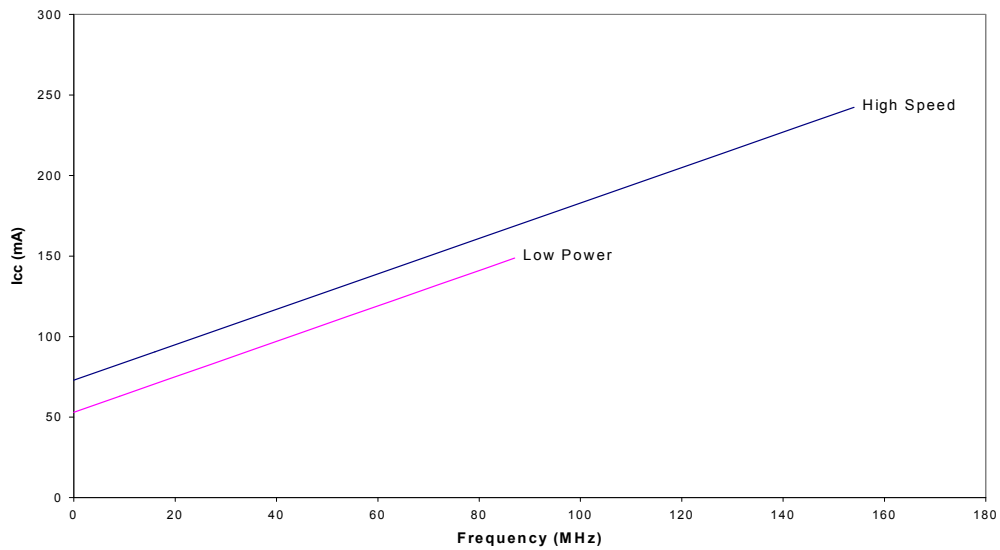

The typical pattern is a 16-bit up counter, per logic block, with outputs disabled.
 $V_{CC} = 5V$, $T_A = \text{Room Temperature}$

"Not Recommended for New Design"

Typical 5 V Power Consumption (continued)
CY37256

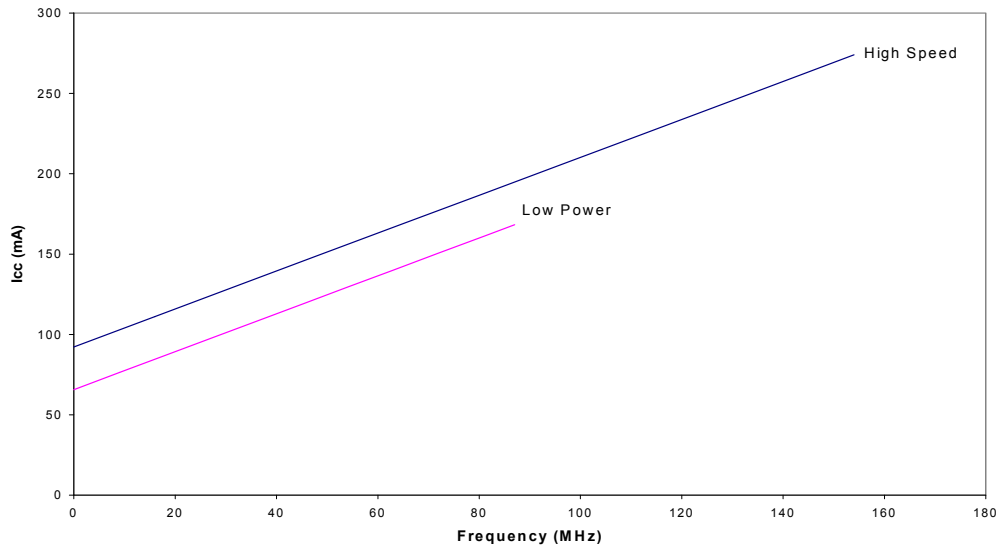

The typical pattern is a 16-bit up counter, per logic block, with outputs disabled.
 $V_{CC} = 5V$, $T_A = \text{Room Temperature}$

"Not Recommended for New Design"

Typical 3.3 V Power Consumption CY37032V

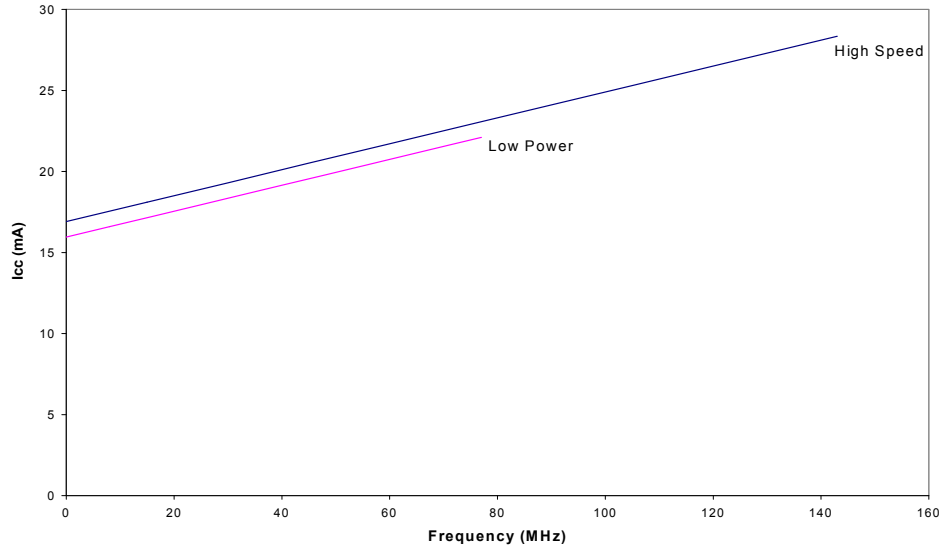

The typical pattern is a 16-bit up counter, per logic block, with outputs disabled.
 $V_{CC} = 3.3V$, $T_A = \text{Room Temperature}$

CY37064V

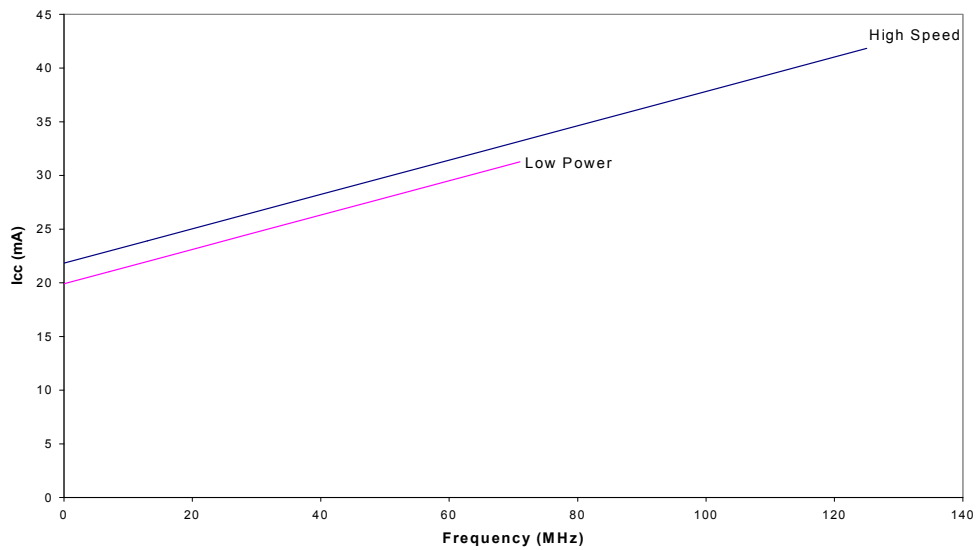

The typical pattern is a 16-bit up counter, per logic block, with outputs disabled.
 $V_{CC} = 3.3V$, $T_A = \text{Room Temperature}$

"Not Recommended for New Design"

Typical 3.3 V Power Consumption (continued) CY37128V

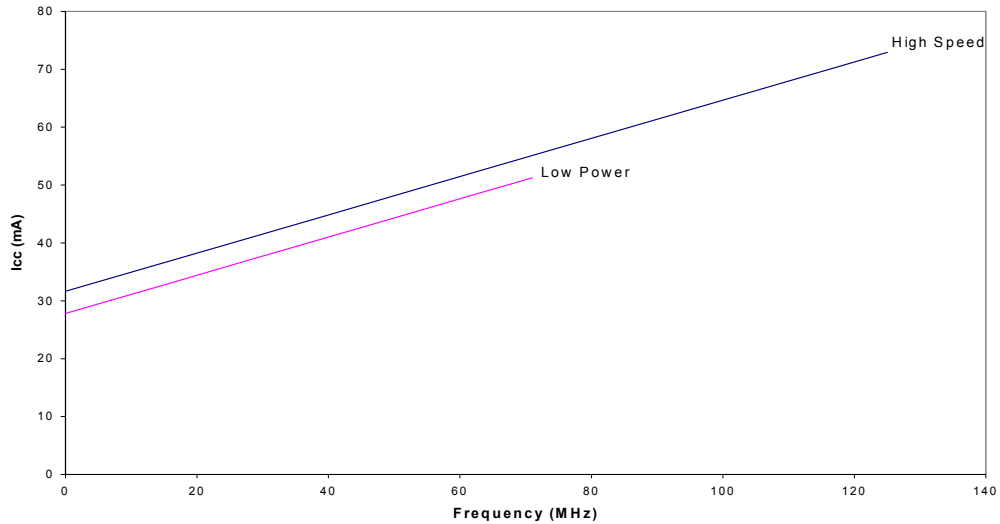

The typical pattern is a 16-bit up counter, per logic block, with outputs disabled.
 $V_{CC} = 3.3V$, $T_A = \text{Room Temperature}$

CY37192V

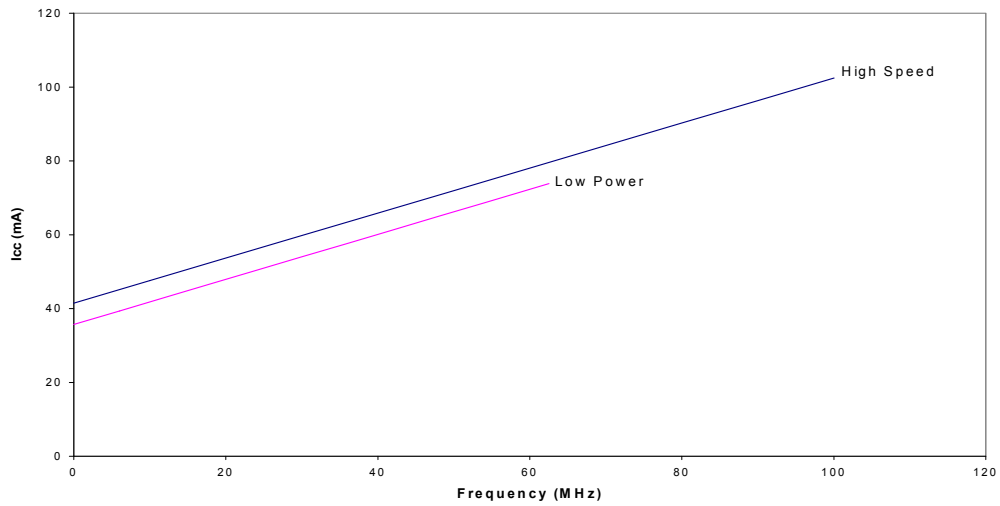

The typical pattern is a 16-bit up counter, per logic block, with outputs disabled.
 $V_{CC} = 3.3V$, $T_A = \text{Room Temperature}$

"Not Recommended for New Design"

Typical 3.3 V Power Consumption (continued)
CY37256V

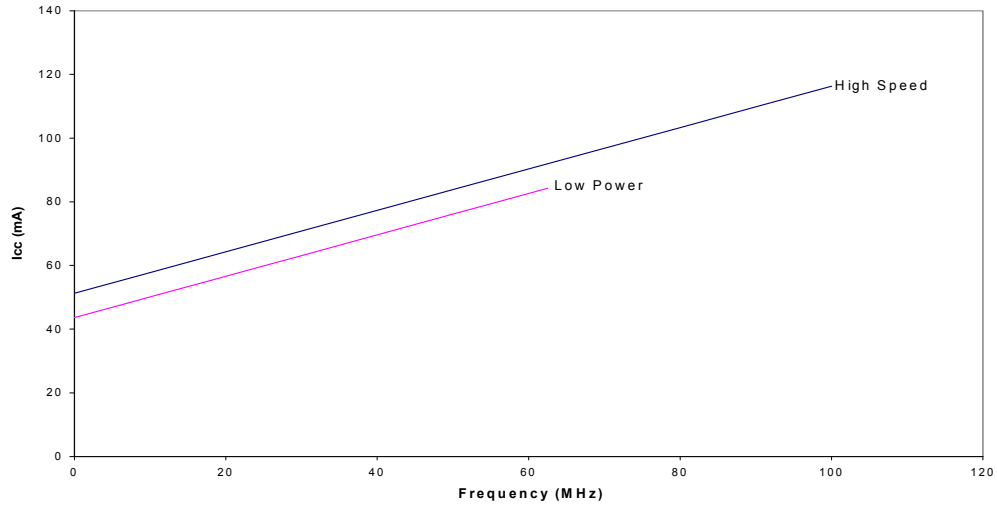

The typical pattern is a 16-bit up counter, per logic block, with outputs disabled.
 $V_{CC} = 3.3V$, $T_A = \text{Room Temperature}$

"Not Recommended for New Design"

Ordering Information

5 V Ordering Information

Macrocells	Speed (MHz)	Ordering Code	Package Name	Package Type	Operating Range
32	154	CY37032P44-154AXI	A44	44-pin TQFP (Pb-free)	Industrial
	125	CY37032P44-125AXC	A44	44-pin TQFP (Pb-free)	Commercial
		CY37032P44-125JXC	J67	44-pin PLCC (Pb-free)	
64	125	CY37064P44-125AXC	A44	44-pin TQFP (Pb-free)	Commercial
		CY37064P44-125JXC	J67	44-pin PLCC (Pb-free)	
		CY37064P100-125AXC	A100	100-pin TQFP (Pb-free)	
	100	CY37064P44-125AXI	A44	44-pin TQFP (Pb-free)	Industrial
		CY37064P100-125AXI	A100	100-pin TQFP (Pb-free)	
128	125	CY37128P100-125AXC	A100	100-pin TQFP (Pb-free)	Commercial
		CY37128P160-125AXC	A160	160-pin TQFP (Pb-free)	
		CY37128P100-125AXI	A100	100-pin TQFP (Pb-free)	Industrial
		CY37128P160-125AXI	A160	160-pin TQFP (Pb-free)	
	100	CY37128P160-100AXC	A160	160-pin TQFP (Pb-free)	Commercial
192	83	CY37192P160-83AXC	A160	160-pin TQFP (Pb-free)	Commercial
		CY37192P160-83AXI	A160	160-pin TQFP (Pb-free)	Industrial
256	125	CY37256P160-125AXC	A160	160-pin TQFP (Pb-free)	Commercial
		CY37256P160-125AXI	A160	160-pin TQFP (Pb-free)	Industrial
	83	CY37256P160-83AXC	A160	160-pin TQFP (Pb-free)	Commercial
		CY37256P160-83AXI	A160	160-pin TQFP (Pb-free)	Industrial

3.3 V Ordering Information

Macrocells	Speed (MHz)	Ordering Code	Package Name	Package Type	Operating Range
32	143	CY37032VP44-143AXC	A44	44-pin TQFP (Pb-free)	Commercial
	100	CY37032VP44-100AXC	A44	44-pin TQFP (Pb-free)	
64	100	CY37064VP44-100AXC	A44	44-pin TQFP (Pb-free)	Commercial
128	125	CY37128VP100-125AXC	A100	100-pin TQFP (Pb-free)	Commercial
	83	CY37128VP160-83AXI	A160	160-pin TQFP (Pb-free)	Industrial

"Not Recommended for New Design"

Ordering Code Definitions

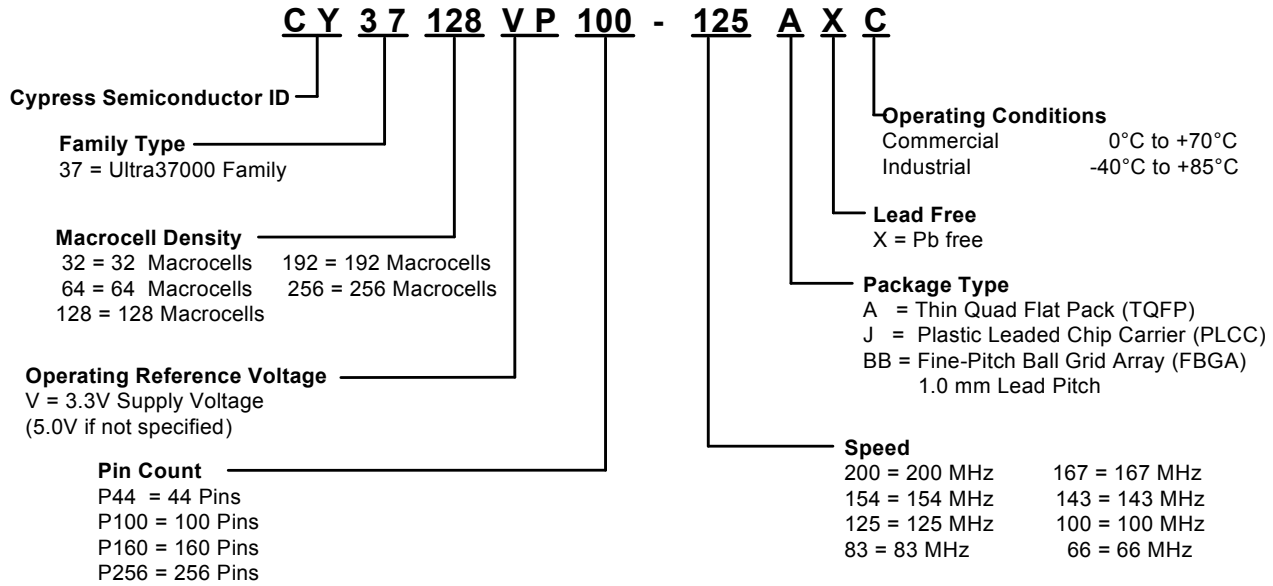

"Not Recommended for New Design"

Package Diagrams

Figure 27. 44-pin TQFP (10 × 10 × 1.4 mm) A44S Package Outline, 51-85064

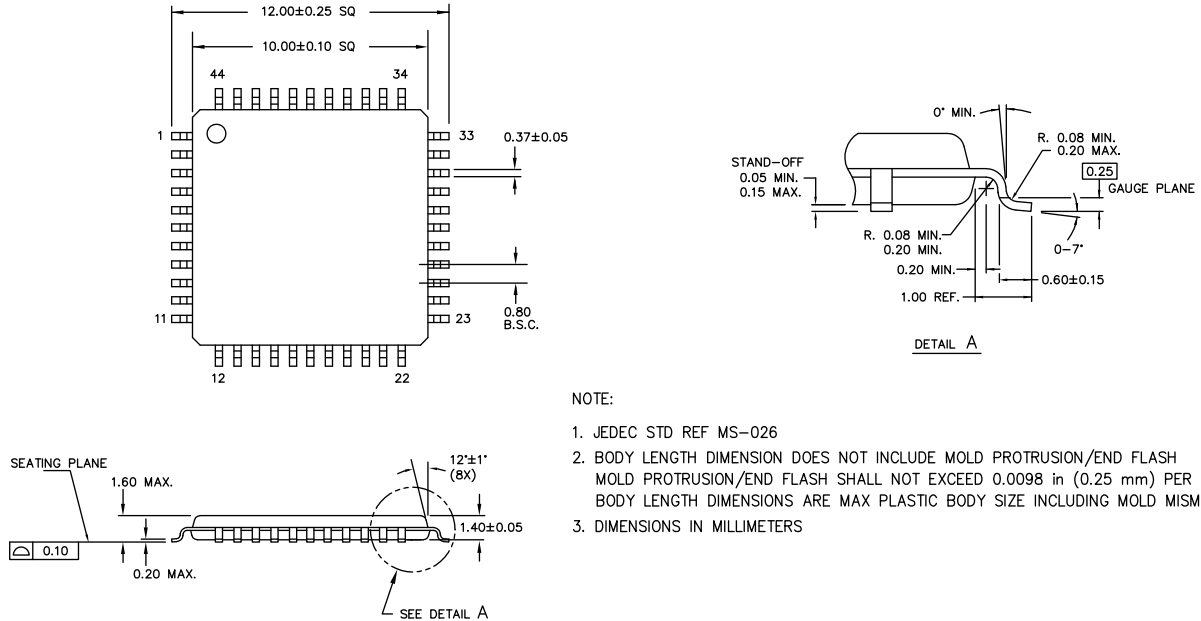

51-85064 *E

Figure 28. 44-pin PLCC J44 Package Outline, 51-85003

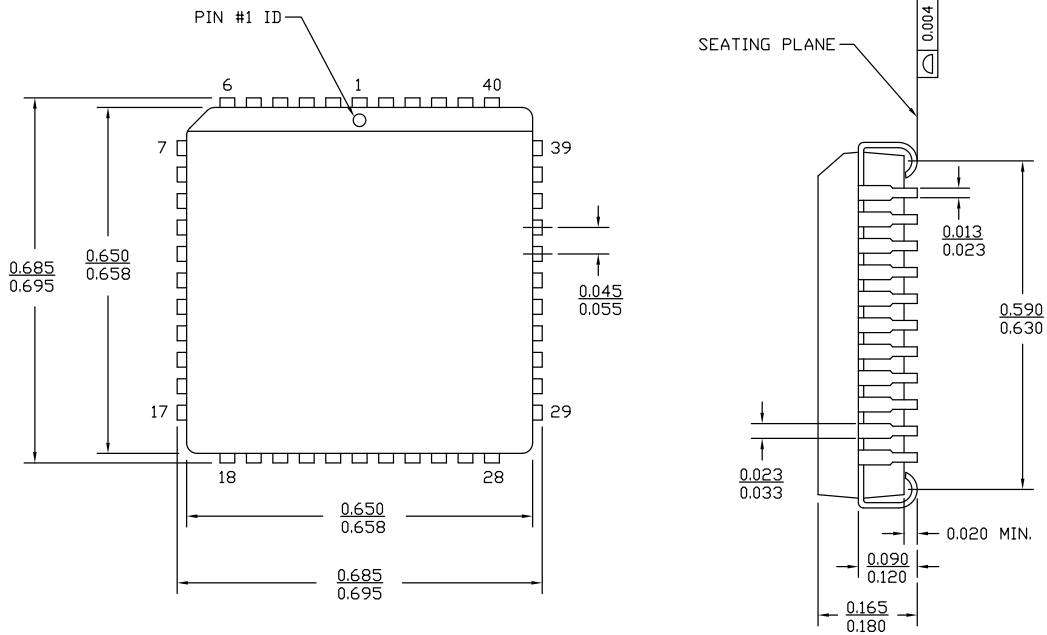

DIMENSIONS IN INCHES MIN.
MAX.

51-85003 *C

"Not Recommended for New Design"

Package Diagrams (continued)

Figure 29. 100-pin TQFP (14 × 14 × 1.4 mm) A100SA Package Outline, 51-85048

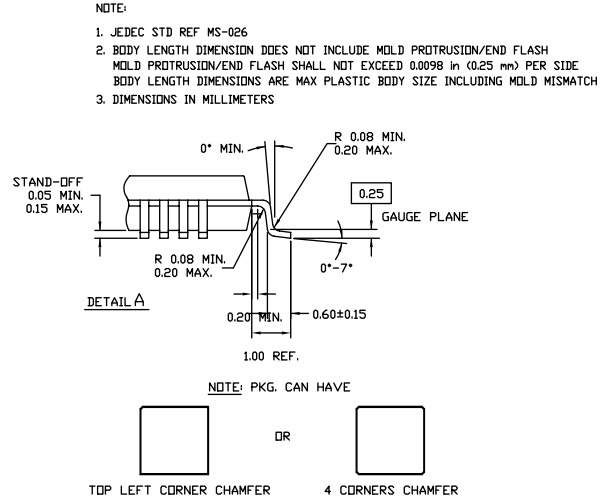
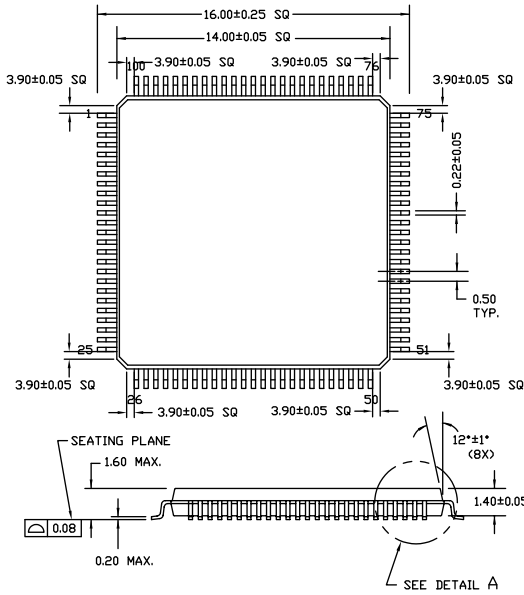

51-85048 *G

Figure 30. 160-pin TQFP (24 × 24 × 1.4 mm) A160SA Package Outline, 51-85049

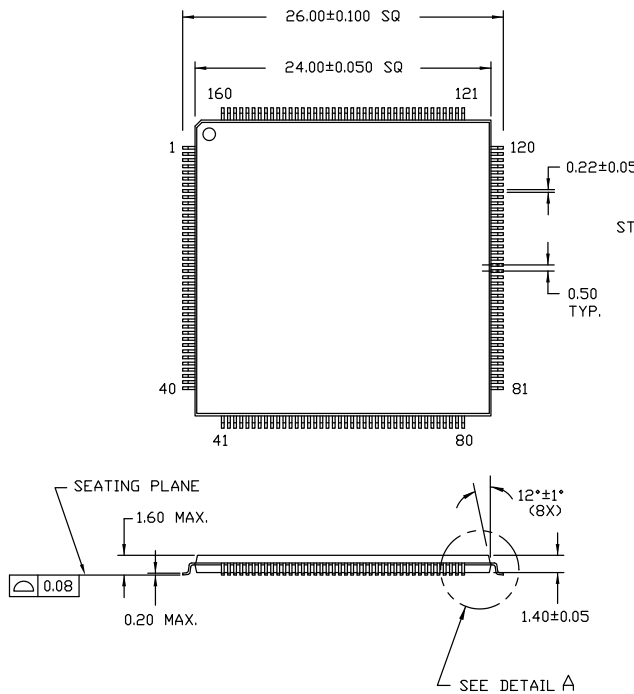

DIMENSIONS ARE IN MILLIMETERS.

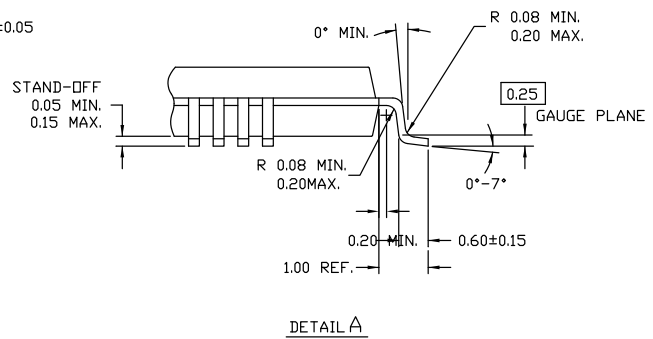

51-85049 *D

"Not Recommended for New Design"

Package Diagrams (continued)

Figure 31. 256-ball FBGA (17 × 17 × 1.7 mm) BB256/BW0BD Package Outline, 51-85108

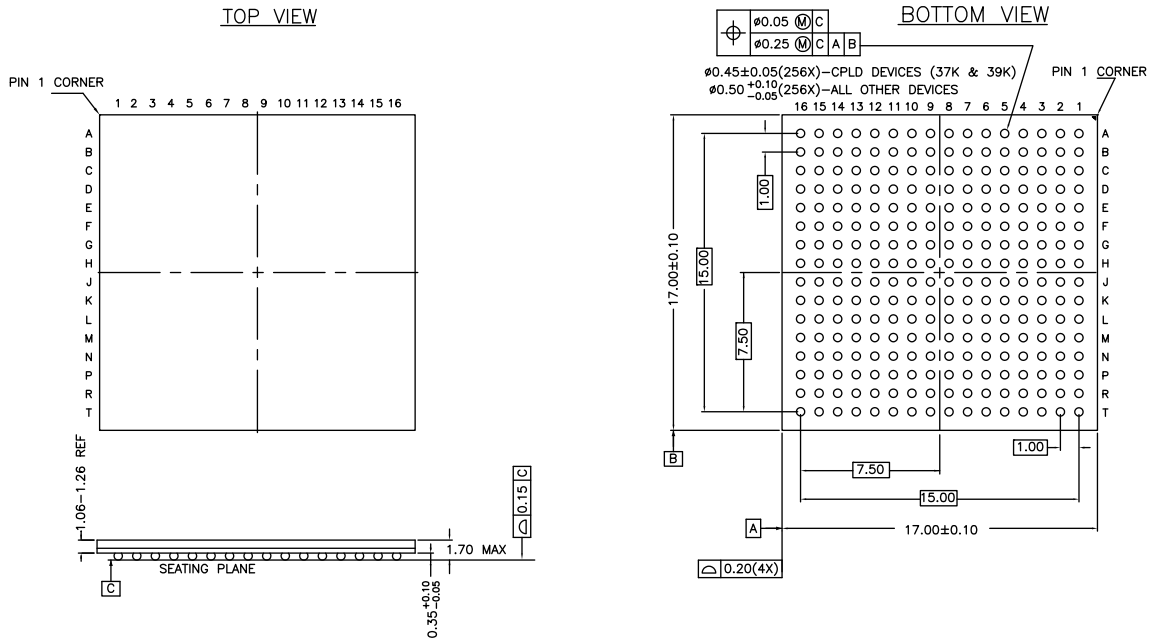

REFERENCE JEDEC MO-192 PACKAGE WEIGHT - 0.95gr

51-85108 *1

"Not Recommended for New Design"

Acronyms

Acronym	Description
ATE	automatic test equipment
CMOS	complementary metal oxide semiconductor
CPLD	complex programmable logic device
FBGA	fine-pitch ball grid array
I/O	input/output
ISR	in-system reprogrammable
JEDEC	joint electron devices engineering council
JTAG	joint test action group
OE	output enable
PC	personal computer
PCI	peripheral component interconnect
PIM	programmable interconnect matrix
PLCC	plastic leaded chip carrier
TDI	test data-in
TDO	test data-out
TQFP	thin quad flat pack
TTL	transistor-transistor logic

Document Conventions

Units of Measure

Symbol	Unit of Measure
°C	degree Celsius
MHz	megahertz
μA	microampere
mm	millimeter
ms	millisecond
nH	nanohenry
ns	nanosecond
Ω	ohm
%	percent
pF	picofarad
V	volt
W	watt

Document History Page

Document Title: Ultra37000 CPLD Family, 5 V and 3.3 V ISR™ High Performance CPLDs				
Document Number: 38-03007				
Rev.	ECN No.	Submission Date	Orig. of Change	Description of Change
**	106272	04/18/01	SZV	Change from Spec number: 38-00475 to 38-03007
*A	124942	03/21/03	OOR	Updated 3.3V V _{CC} requirements for –144 speeds Added an Addendum
*B	126262	05/09/03	TEH	Changed pinout for CY37128V BB100 package
*C	128125	07/16/03	HOM	Obsoleted following 3.3V PLCC packaged devices: CY37032VP44-143JC CY37032VP44-100JC CY37032VP44-100JI CY37064VP44-143JC CY37064VP84-143JC CY37064VP44-100JC CY37064VP84-100JC CY37064VP44-100JI CY37064VP84-100JI CY37128VP84-125JC CY37128VP84-83JC CY37128VP84-83JI
*D	282709	11/08/04	YDT	Changed package diagrams and labels for consistency Added Pb-free logo on first page, and a note in Features Added Pb-free package diagram labels Added Pb-free Parts to Ordering Information CY37032P44-200AXC, CY37032P44-200JXC, CY37032P44-154AXI, CY37032P44-154JXI, CY37032P44-125AXC, CY37032P44-125JXC, CY37064P44-200AXC, CY37064P44-200JXC, CY37064P100-200AXC, CY37064P44-154AXI, CY37064P44-154JXI, CY37064P44-125AXC, CY37064P44-125JXC, CY37064P100-125AXC, CY37064P44-125AXI, CY37064P100-125AXI, CY37128P84-167JXC, CY37128P100-167AXC, CY37128P160-167AXC, CY37128P84-125JXC, CY37128P100-125AXC, CY37128P160-125AXC, CY37128P84-125JXI, CY37128P100-125AXI, CY37128P160-125AXI, CY37128P84-100JXC, CY37128P100-100AXC, CY37128P160-100AXC, CY37128P100-100AXI, CY37192P160-154AXC, CY37192P160-125AXC, CY37192P160-125AXI, CY37192P160-83AXC, CY37192P160-83AXI, CY37256P160-154AXC, CY37256P160-125AXC, CY37256P160-125AXI, CY37256P160-83AXC, CY37256P160-83AXI, CY37032VP44-143AXC, CY37032VP44-100AXC, CY37032VP44-100AXI, CY37032VP44-100JXI, CY37064VP44-143AXC, CY37064VP100-143AXC, CY37064VP44-100AXC, CY37064VP100-100AXC, CY37064VP44-100AXI, CY37064VP100-100AXI, CY37128VP100-125AXC, CY37128VP160-125AXC, CY37128VP160-125AXI, CY37128VP100-83AXC, CY37128VP160-83AXC, CY37128VP100-83AXI, CY37128VP160-83AXI, CY37192VP160-100AXC, CY37192VP160-66AXC, CY37256VP160-100AXC, CY37256VP160-100AXI, CY37256VP160-66AXC
*E	321635	03/14/05	PCX	Added Package Diagram BG292 Updated all PBGA package type information (BG292 & BG388)

"Not Recommended for New Design"

Document History Page (continued)

Document Title: Ultra37000 CPLD Family, 5 V and 3.3 V ISR™ High Performance CPLDs				
Document Number: 38-03007				
Rev.	ECN No.	Submission Date	Orig. of Change	Description of Change
*F	2813051	12/04/09	AAE	<p>a. In the features section, reduced the maximum number of pins from 400 to 256 in reference to current package pin count in production.</p> <p>b. 5V Selection Guide: Removed CY37384 and CY37512 options from the general information table, removed CY37384 and CY37512 options from the Speed Bins table, removed all in-active speed bin options, removed all in-active device-package offering and I/O count options.</p> <p>c. 3.3V Selection Guide: Removed CY37384V and CY37512V options from the general information table, removed CY37384V and CY37512V options from the Speed Bins table, removed all in-active speed bin options, removed all in-active device-package offering and I/O count options.</p> <p>d. Updated the development software support specific to Programming in which the CY3700i (ISR Programming Kit) reference had been replaced with the CYUSBISRPC Programming Cable User's Guide.</p> <p>e. Logic diagrams: Removed references to CY37384/ CY37384V and CY37512/ CY37512V.</p> <p>f. 5V Device Electrical Characteristics specific to the Inductance table: Removed 44 pin CLCC, 84 pin PLCC, 84 pin CLCC and 208 pin PQFP from the table.</p> <p>g. 3.3V Device Electrical Characteristics specific to the Inductance table: Removed 44 pin CLCC, 84 pin PLCC, 84 pin CLCC and 208 pin PQFP from the table.</p> <p>h. Note 10: Updated CY37064VP100-AC to CY37064VP100-AXC and CY37064VP44-143AC to CY37064VP44-143AXC. Removed references to CY37064VP100-143BBC and CY37064VP48-143BAC because these are obsolete device-package options.</p> <p>i. Note 16: Removed CY37384 device as a reference.</p> <p>j. Note 18: Removed CY37384V device as a reference.</p> <p>k. Power Consumption graphs: Removed reference graphs for CY37384, CY37512, CY37384V and CY37512V.</p> <p>l. Pin Configurations: Removed reference pin-outs for 44 Pin CLCC, 48B FBGA, 84 Pin PLCC, 84 Pin CLCC, 100B FBGA, 160 pin CQFP, 208 pin CQFP, 208 pin PQFP, 292B PBGA, 388B PBGA, and 400B FBGA.</p>

"Not Recommended for New Design"

Document History Page (continued)

Document Title: Ultra37000 CPLD Family, 5 V and 3.3 V ISR™ High Performance CPLDs Document Number: 38-03007				
Rev.	ECN No.	Submission Date	Orig. of Change	Description of Change
*F (cont)	2813051	12/04/09	AAE	m. Updated the 5 V Ordering Information: Removed the following obsolete part numbers: CY37032P44-200AC, CY37032P44-200AXC, CY37032P44-200JC, CY37032P44-200JXC, CY37032P44-154AC, CY37032P44-154JC, CY37032P44-154AI, CY37032P44-154JI, CY37032P44-154JXI, CY37032P44-125AC, CY37032P44-125JC, CY37032P44-125AI, CY37032P44-125JI, CY37064P44-200AC, CY37064P44-200AXC, CY37064P44-200JC, CY37064P44-200JXC, CY37064P84-200JC, CY37064P100-200AC, CY37064P44-154AC, CY37064P44-154JC, CY37064P84-154JC, CY37064P100-154AC, CY37064P44-154AI, CY37064P44-154JI, CY37064P100-154AI, CY37064P44-125AC, CY37064P44-125JC, CY37064P84-125JC, CY37064P100-125AC, CY37064P44-125AI, CY37064P44-125JI, CY37064P84-125JI, CY37064P100-125AI, 5962-9951901QYA, CY37128P84-167JC, CY37128P84-167JXC, CY37128P100-167AC, CY37128P100-167AXC, CY37128P160-167AC, CY37128P84-125JC, CY37128P84-125JXC, CY37128P100-125AC, CY37128P160-125AC, CY37128P84-125JI, CY37128P84-125JXI, CY37128P100-125AI, CY37128P160-125AI, 5962-9952102QYA, CY37128P84-100JC, CY37128P84-100JXC, CY37128P100-100AC, CY37128P160-100AC, CY37128P84-100JI, CY37128P100-100AI, CY37128P100-100AXI, CY37128P160-100AI, 5962-9952101QYA, CY37192P160-154AC, CY37192P160-154AXC, CY37192P160-125AC, CY37192P160-125AI, CY37192P160-83AC, CY37192P160-83AI, CY37256P160-154AC, CY37256P160-154AXC, CY37256P208-154NC, CY37256P256-154BGC, CY37256P160-125AC, CY37256P208-125NC, CY37256P256-125BGC, CY37256P160-125AI, CY37256P208-125NI, CY37256P256-125BGI, 5962-9952302QZC, CY37256P160-83AC, CY37256P208-83NC, CY37256P256-83BGC, CY37256P160-83AI, CY37256P208-83NI, CY37256P256-83BGI, CY37384P208-125NC, CY37384P256-125BGC, CY37384P208-83NC, CY37384P256-83BGC, CY37384P208-83NI, 5962-9952301QZC, CY37384P256-83BG, CY37512P208-125NC, CY37512P256-125BGC, CY37512P208-100NC, CY37512P256-100BGC, CY37512P352-100BGC, CY37512P208-100NI, CY37512P256-100BGI, CY37512P352-100BGI, 5962-9952502QZC, CY37512P208-83NC, CY37512P256-83BGC, CY37512P352-83BGC, CY37512P208-83NI, CY37512P256-83BGI, CY37512P352-83BGI, 5962-9952501QZC.

"Not Recommended for New Design"

Document History Page (continued)

Document Title: Ultra37000 CPLD Family, 5 V and 3.3 V ISR™ High Performance CPLDs Document Number: 38-03007				
Rev.	ECN No.	Submission Date	Orig. of Change	Description of Change
*F (cont)	2813051	12/04/09	AAE	n. Updated the 3.3V Ordering Information: Removed the following obsolete part numbers: CY37032VP44-143AC, CY37032VP48-143BAC, CY37032VP44-100AC, CY37032VP48-100BAC, CY37032VP44-100AI, CY37032VP44-100AXI, CY37032VP48-100BAI, CY37032VP44-100JI, CY37032VP44-100JXI, CY37064VP44-143AC, CY37064VP48-143BAC, CY37064VP100-143AC, CY37064VP100-143BBC, CY37064VP44-100AC, CY37064VP48-100BAC, CY37064VP100-100AC, CY37064VP100-100BBC, CY37064VP44-100AI, CY37064VP44-100AXI, CY37064VP48-100BAI, CY37064VP100-100BBI, CY37064VP100-100AI, 5962-9952001QYA, CY37128VP100-125AC, CY37128VP100-125BBC, CY37128VP160-125AC, CY37128VP160-125AI, CY37128VP100-83AC, CY37128VP100-83BBC, CY37128VP160-83AC, CY37128VP100-83AI, CY37128VP100-83BBI, CY37128VP160-83AI, 5962-9952201QYA, CY37192VP160-100AC, CY37192VP160-66AC, CY37192VP160-66AI, CY37256VP160-100AC, CY37256VP208-100NC, CY37256VP256-100BGC, CY37256VP256-100BBC, CY37256VP160-100AI, CY37256VP160-66AC, CY37256VP208-66NC, CY37256VP256-66BGC, CY37256VP160-66AI, CY37256VP256-66BGI, 5962-9952401QZC, CY37384VP208-83NC, CY37384VP256-83BGC, CY37384VP208-66NC, CY37384VP256-66BGC, CY37384VP208-66NI, CY37384VP256-66BGI, CY37512VP208-83NC, CY37512VP256-83BGC, CY37512VP352-83BGC, CY37512VP400-83BBC, CY37512VP208-66NC, CY37512VP256-66BGC, CY37512VP352-66BGC, CY37512VP400-66BBC, CY37512VP208-66NI, CY37512VP256-66BGI, CY37512VP352-66BGI, CY37512VP400-66BBI, 5962-9952601QZC.
*F (cont)	2813051	12/04/09	AAE	o. Updated package diagram drawing revisions on the following: 51-85064, 51-85003, 51-85048. p. Removed package diagram drawing references for obsoleted part numbers: 44 pin CLCC (51-80014), 48FBGA (51-85109), 84 pin CLCC (51-80095), 100B FBGA (51-85107), 160 pin CQFP (51-80106), 208 pin PQFP (51-85069), 208 pin CQFP (51-80105), 292B PBGA (51-85097), 388B PBGA (51-85103), 400B FBGA (51-85111). q. Addendum for 3.3V Operating Range: Updated CY37064VP100-AC to CY37064VP100-AXC and CY37064VP44-143AC to CY37064VP44-143AXC. Removed references to CY37064VP100-143BBC and CY37064VP48-143BAC because these are obsolete device-package options. r. Removed Military Operating Range because all Military Part numbers have been obsoleted.
*G	2896152	03/19/2010	AAE	Removed inactive parts from Ordering Information. Updated Table of Contents. Updated Packaging Information. Updated links in Sales, Solutions, and Legal Information.
*H	3081920	11/09/2010	AAE	Updated Ordering Information and Ordering Code Definitions . Minor edits.
*I	3721588	08/23/2012	AAE	Updated Package Diagrams (spec 51-85064 (Changed revision from *D to *E), spec 51-85003 (Changed revision from *B to *C), spec 51-85048 (Changed revision from *D to *G), spec 51-85049 (Changed revision from *C to *D), spec 51-85108 (Changed revision from *H to *I)). Added Acronyms and Units of Measure . Updated in new template.

"Not Recommended for New Design"

Sales, Solutions, and Legal Information

Worldwide Sales and Design Support

Cypress maintains a worldwide network of offices, solution centers, manufacturer's representatives, and distributors. To find the office closest to you, visit us at [Cypress Locations](#).

Products

Automotive	cypress.com/go/automotive
Clocks & Buffers	cypress.com/go/clocks
Interface	cypress.com/go/interface
Lighting & Power Control	cypress.com/go/powerpsoc cypress.com/go/plc
Memory	cypress.com/go/memory
PSoC	cypress.com/go/psoc
Touch Sensing	cypress.com/go/touch
USB Controllers	cypress.com/go/USB
Wireless/RF	cypress.com/go/wireless

PSoC Solutions

[psoc.cypress.com/solutions](#)
PSoC 1 | PSoC 3 | PSoC 5

© Cypress Semiconductor Corporation, 2001-2012. The information contained herein is subject to change without notice. Cypress Semiconductor Corporation assumes no responsibility for the use of any circuitry other than circuitry embodied in a Cypress product. Nor does it convey or imply any license under patent or other rights. Cypress products are not warranted nor intended to be used for medical, life support, life saving, critical control or safety applications, unless pursuant to an express written agreement with Cypress. Furthermore, Cypress does not authorize its products for use as critical components in life-support systems where a malfunction or failure may reasonably be expected to result in significant injury to the user. The inclusion of Cypress products in life-support systems application implies that the manufacturer assumes all risk of such use and in doing so indemnifies Cypress against all charges.

Any Source Code (software and/or firmware) is owned by Cypress Semiconductor Corporation (Cypress) and is protected by and subject to worldwide patent protection (United States and foreign), United States copyright laws and international treaty provisions. Cypress hereby grants to licensee a personal, non-exclusive, non-transferable license to copy, use, modify, create derivative works of, and compile the Cypress Source Code and derivative works for the sole purpose of creating custom software and or firmware in support of licensee product to be used only in conjunction with a Cypress integrated circuit as specified in the applicable agreement. Any reproduction, modification, translation, compilation, or representation of this Source Code except as specified above is prohibited without the express written permission of Cypress.

Disclaimer: CYPRESS MAKES NO WARRANTY OF ANY KIND, EXPRESS OR IMPLIED, WITH REGARD TO THIS MATERIAL, INCLUDING, BUT NOT LIMITED TO, THE IMPLIED WARRANTIES OF MERCHANTABILITY AND FITNESS FOR A PARTICULAR PURPOSE. Cypress reserves the right to make changes without further notice to the materials described herein. Cypress does not assume any liability arising out of the application or use of any product or circuit described herein. Cypress does not authorize its products for use as critical components in life-support systems where a malfunction or failure may reasonably be expected to result in significant injury to the user. The inclusion of Cypress' product in a life-support systems application implies that the manufacturer assumes all risk of such use and in doing so indemnifies Cypress against all charges.

Use may be limited by and subject to the applicable Cypress software license agreement.

X-ON Electronics

Largest Supplier of Electrical and Electronic Components

Click to view similar products for [CPLD - Complex Programmable Logic Devices](#) category:

Click to view products by [Cypress](#) manufacturer:

Other Similar products are found below :

[5962-9952001QYA](#) [5M1270ZT144I5](#) [M4A5-12864-10YNI](#) [M4A5-12864-12YNI](#) [M4A5-3232-5VNC](#) [M4A5-6432-7VNI](#) [CY3LV002-10JC](#)
[CY7C344B-15JI](#) [ISPLSI 1032-90LJ](#) [ISPLSI 1048-70LQ](#) [LA4064V-75TN44E](#) [LC4064ZC-5MN56C](#) [M4A3-3232-10VC](#) [M4A5-256128-12YNI](#) [MACH435Q-20JC](#) [ISPLSI 1032-60LJ](#) [ISPLSI 1032-80LJ](#) [ISPLSI 1048-50LQ](#) [LA4032V-75TN44E](#) [LC4032ZC-5MN56I](#) [5962-9759901QZC](#) [XC95288XL-10CS280I](#) [LC4032ZC-75MN56I](#) [LC5512MV-45F256C](#) [M4A5-6432-10VNI](#) [ISPLSI2096A-80LT128I](#) [M4A3-256192-10FAI](#) [LA4128V-75TN128E](#) [M4A3-3232-5VC48](#) [M4A3-64/32-12VNI48](#) [CP4878DM](#) [M4A3-256/160-7YC](#) [M4A3-32/32-10VNC48](#) [M4A3-384/192-10FANC](#) [M4A3-512/160-14YI](#) [M4A5-128/64-7YI](#) [M4A5-192/96-10VC](#) [M4A5-192/96-10VI](#) [M4A5-256/128-10YNC](#) [M4A5-256/128-7YC](#) [M4A5-32/32-10VC](#) [M4A5-64/32-10VNC](#) [M5-192/120-10YI/1](#) [M5-320/160-10YI](#) [M5-320/160-12YC](#) [CY37032P44-125JI](#) [CY37032VP44-100AXC](#) [CY37064P44-154JI](#) [CY37064P84-125JXC](#) [CY37064P84-154JXIT](#)