

Features

- Very high speed: 55 ns
- Wide voltage range: 1.65 V to 2.25 V
- Pin compatible with CY62137CV18
- Ultra low standby power
 - Typical standby current: 1 μ A
 - Maximum standby current: 5 μ A
- Ultra low active power
 - Typical active current: 1.6 mA @ f = 1 MHz
- Easy memory expansion with \overline{CE} and \overline{OE} features
- Automatic power down when deselected
- Complementary metal oxide semiconductor (CMOS) for optimum speed and power
- Byte power-down feature
- Available in a Pb-free 48-ball Very fine-pitch ball grid package (VFBGA) package

Functional Description

The CY62137FV18 is a high performance CMOS static RAM organized as 128K words by 16 bits. This device features advanced circuit design to provide ultra low active current. This is ideal for providing More Battery Life™ (MoBL®) in portable

applications such as cellular telephones. The device also has an automatic power down feature that significantly reduces power consumption when addresses are not toggling. Placing the device into standby mode reduces power consumption by more than 99% when deselected (\overline{CE} HIGH or both \overline{BLE} and \overline{BHE} are HIGH). The input and output pins (I/O₀ through I/O₁₅) are placed in a high impedance state when the device is deselected (\overline{CE} HIGH), the outputs are disabled (\overline{OE} HIGH), both the Byte High Enable and the Byte Low Enable are disabled (\overline{BHE} , \overline{BLE} HIGH), or during an active write operation (\overline{CE} LOW and \overline{WE} LOW).

To write to the device, take Chip Enable (\overline{CE}) and Write Enable (\overline{WE}) inputs LOW. If Byte Low Enable (\overline{BLE}) is LOW, then data from I/O pins (I/O₀ through I/O₇) is written into the location specified on the address pins (A₀ through A₁₆). If Byte High Enable (\overline{BHE}) is LOW, then data from I/O pins (I/O₈ through I/O₁₅) is written into the location specified on the address pins (A₀ through A₁₆).

To read from the device, take Chip Enable (\overline{CE}) and Output Enable (\overline{OE}) LOW while forcing the Write Enable (\overline{WE}) HIGH. If Byte Low Enable (\overline{BLE}) is LOW, then data from the memory location specified by the address pins appear on I/O₀ to I/O₇. If Byte High Enable (\overline{BHE}) is LOW, then data from the memory appears on I/O₈ to I/O₁₅. See the [Truth Table on page 11](#) for a complete description of read and write modes.

For a complete list of related documentation, [click here](#).

Logic Block Diagram

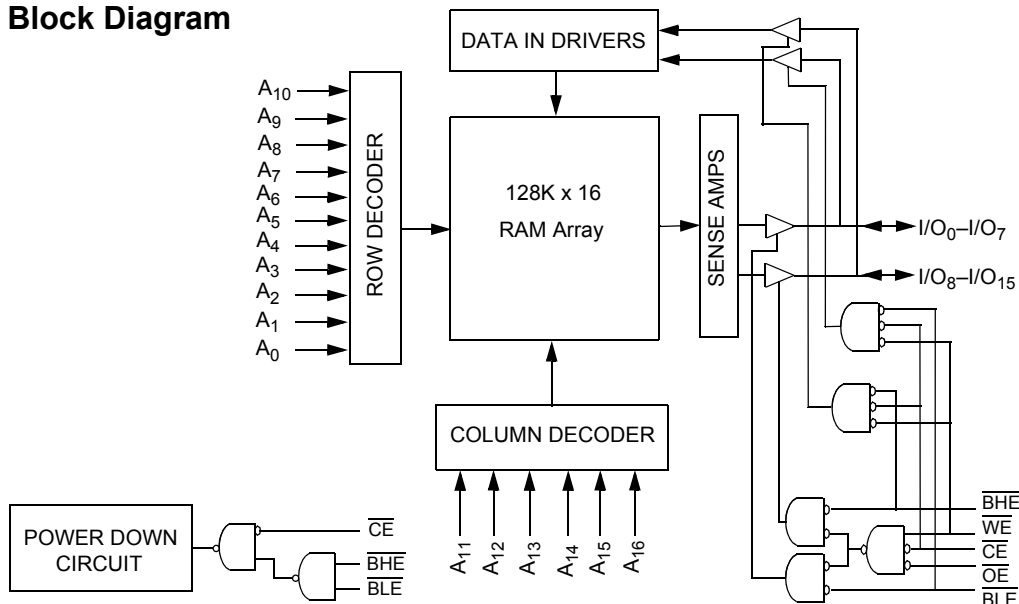

Contents

Product Portfolio	3	Ordering Information	12
Pin Configuration	3	Ordering Code Definitions	12
Maximum Ratings	4	Package Diagram	13
Operating Range	4	Acronyms	14
Electrical Characteristics	4	Document Conventions	14
Capacitance	5	Units of Measure	14
Thermal Resistance	5	Document History Page	15
AC Test Loads and Waveforms	5	Sales, Solutions, and Legal Information	16
Data Retention Characteristics	6	Worldwide Sales and Design Support	16
Data Retention Waveform	6	Products	16
Switching Characteristics	7	PSoC® Solutions	16
Switching Waveforms	8	Cypress Developer Community	16
Truth Table	11	Technical Support	16

Product Portfolio

Product	V _{CC} Range (V)			Speed (ns)	Power Dissipation					
					Operating I _{CC} (mA)				Standby I _{SB2} (μA)	
	f = 1 MHz		f = f _{max}							
	Min	Typ ^[1]	Max		Typ ^[1]	Max	Typ ^[1]	Max	Typ ^[1]	Max
CY62137FV18LL	1.65	1.8	2.25	55	1.6	2.5	13	18	1	5

Pin Configuration

Figure 1. 48-ball VFBGA pinout [2, 3]

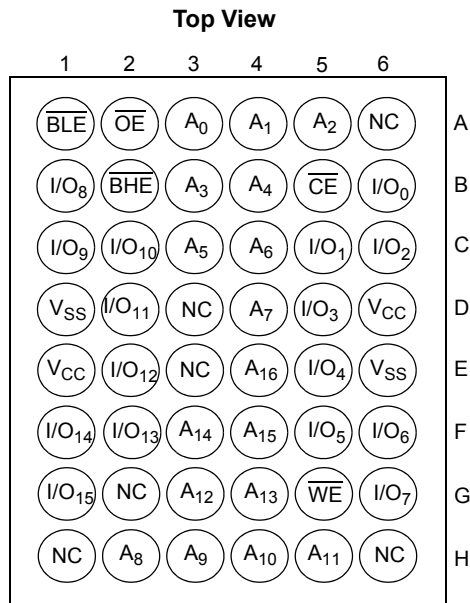

Notes

1. Typical values are included for reference only and are not guaranteed or tested. Typical values are measured at V_{CC} = V_{CC(typ)}, T_A = 25 °C.
2. NC pins are not connected on the die.
3. Pins D3, H1, G2, H6 and H3 in the VFBGA package are address expansion pins for 4 Mb, 8 Mb, 16 Mb, and 32 Mb and 64 Mb respectively.

Maximum Ratings

Exceeding maximum ratings may impair the useful life of the device. User guidelines are not tested.

Storage temperature	-65 °C to + 150 °C
Ambient temperature with power applied	-55 °C to + 125 °C
Supply voltage to ground potential	-0.2 V to + 2.45 V
DC voltage applied to outputs in High Z State ^[4, 5]	-0.2 V to 2.45 V

DC Input Voltage ^[4, 5]	-0.2 V to 2.45 V
Output Current into Outputs (LOW)	20 mA
Static Discharge Voltage (MIL-STD-883, Method 3015)	> 2001 V
Latch up Current	> 200 mA

Operating Range

Device	Range	Ambient Temperature	V _{CC} ^[6]
CY62137FV18	Industrial	-40 °C to +85 °C	1.65 V to 2.25 V

Electrical Characteristics

Over the Operating Range

Parameter	Description	Test Conditions	55 ns			Unit	
			Min	Typ ^[7]	Max		
V _{OH}	Output high voltage	I _{OH} = -0.1 mA	1.4	-	-	V	
V _{OL}	Output low voltage	I _{OL} = 0.1 mA	-	-	0.2	V	
V _{IH}	Input high voltage	V _{CC} = 1.65 V to 2.25 V	1.4	-	V _{CC} + 0.2	V	
V _{IL}	Input low voltage	V _{CC} = 1.65 V to 2.25 V	-0.2	-	0.4	V	
I _{IX}	Input leakage current	GND ≤ V _I ≤ V _{CC}	-1	-	+1	μA	
I _{OZ}	Output leakage current	GND ≤ V _O ≤ V _{CC} , output disabled	-1	-	+1	μA	
I _{CC}	V _{CC} operating supply current	f = f _{max} = 1/t _{RC} V _{CC(max)} = 2.25 V I _{OUT} = 0 mA CMOS levels	-	13	18	mA	
		f = 1 MHz V _{CC(max)} = 2.25 V	-	1.6	2.5	mA	
I _{SB1} ^[8]	Automatic power-down current – CMOS inputs	$\overline{CE} \geq V_{CC} - 0.2 \text{ V}$, or (BHE and BLE) ≥ V _{CC} - 0.2 V, V _{IN} ≥ V _{CC} - 0.2 V, V _{IN} ≤ 0.2 V, f = f _{max} (address and data only), f = 0 (OE, WE)	V _{CC(max)} = 2.25 V	-	1	5	μA
I _{SB2} ^[8]	Automatic power-down current – CMOS inputs	$\overline{CE} \geq V_{CC} - 0.2 \text{ V}$, or (BHE and BLE) ≥ V _{CC} - 0.2 V, V _{IN} ≥ V _{CC} - 0.2 V, or V _{IN} ≤ 0.2 V, f = 0	V _{CC(max)} = 2.25 V	-	1	5	μA

Notes

- V_{IL(min)} = -2.0 V for pulse durations less than 20 ns.
- V_{IH(max)} = V_{CC} + 0.5 V for pulse durations less than 20 ns.
- Full device AC operation assumes a minimum of 100 μs ramp time from 0 to V_{CC(min)} and 200 μs wait time after V_{CC} stabilization.
- Typical values are included for reference only and are not guaranteed or tested. Typical values are measured at V_{CC} = V_{CC(typ)}, T_A = 25 °C
- Chip enable (CE) and byte enables (BHE and BLE) must be tied to CMOS levels to meet the I_{SB1} / I_{SB2} / I_{CCDR} spec. Other inputs can be left floating.

Capacitance

Parameter ^[9]	Description	Test Conditions	Max	Unit
C _{IN}	Input capacitance	T _A = 25 °C, f = 1 MHz, V _{CC} = V _{CC(typ)}	10	pF
C _{OUT}	Output capacitance		10	pF

Thermal Resistance

Parameter ^[9]	Description	Test Conditions	48-ball VFBGA	Unit
Θ _{JA}	Thermal resistance (junction to ambient)	Still air, soldered on a 3 × 4.5 inch, two-layer printed circuit board	75	°C/W
Θ _{JC}	Thermal resistance (junction to case)		10	°C/W

AC Test Loads and Waveforms

Figure 2. AC Test Loads and Waveforms

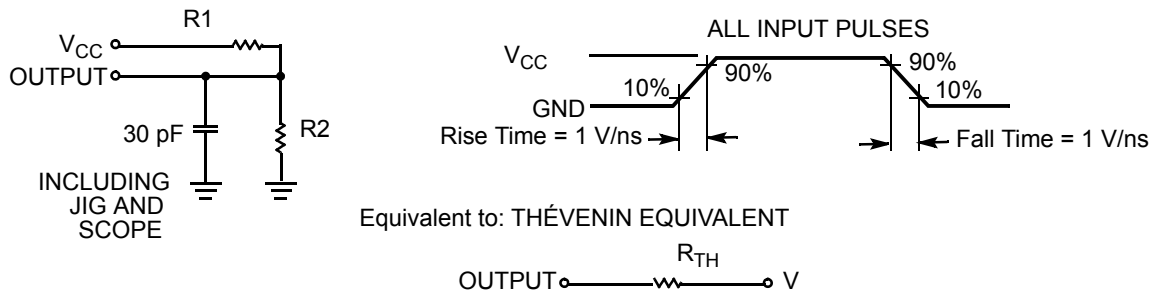

Parameters	1.80 V	Unit
R1	13500	Ω
R2	10800	Ω
R _{TH}	6000	Ω
V _{TH}	0.80	V

Note

9. Tested initially and after any design or process changes that may affect these parameters.

Data Retention Characteristics

Over the Operating Range

Parameter	Description	Conditions	Min	Typ ^[10]	Max	Unit
V_{DR}	V_{CC} for data retention		1.0	–	–	V
$I_{CCDR}^{[11]}$	Data retention current	$V_{CC} = 1.0\text{ V}$, $\overline{CE} \geq V_{CC} - 0.2\text{ V}$, or $(\overline{BHE} \text{ and } \overline{BLE}) \geq V_{CC} - 0.2\text{ V}$, $V_{IN} \geq V_{CC} - 0.2\text{ V}$ or $V_{IN} \leq 0.2\text{ V}$	–	1	4	μA
$t_{CDR}^{[12]}$	Chip deselect to data retention time		0	–	–	ns
$t_R^{[13]}$	Operation recovery time		55	–	–	ns

Data Retention Waveform

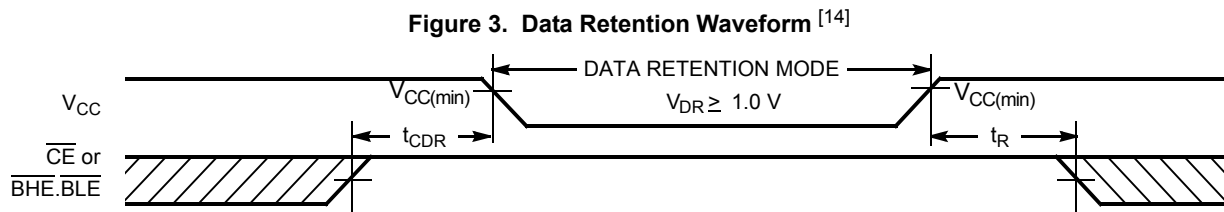

Notes

10. Typical values are included for reference only and are not guaranteed or tested. Typical values are measured at $V_{CC} = V_{CC(\text{typ})}$, $T_A = 25\text{ }^\circ\text{C}$.
11. Chip enable (CE) and byte enables (BHE and BLE) must be tied to CMOS levels to meet the $I_{SB1} / I_{SB2} / I_{CCDR}$ spec. Other inputs can be left floating.
12. Tested initially and after any design or process changes that may affect these parameters.
13. Full device operation requires linear V_{CC} ramp from V_{DR} to $V_{CC(\text{min})} \geq 100\text{ }\mu\text{s}$ or stable at $V_{CC(\text{min})} \geq 100\text{ }\mu\text{s}$.
14. $\overline{BHE.BLE}$ is the AND of both BHE and BLE. Deselect the chip by either disabling chip enable signals or by disabling both \overline{BHE} and \overline{BLE} .

Switching Characteristics

Over the Operating Range

Parameter ^[15, 16]	Description	55 ns		Unit
		Min	Max	
Read Cycle				
t_{RC}	Read cycle time	55	–	ns
t_{AA}	Address to data valid	–	55	ns
t_{OHA}	Data hold from address change	10	–	ns
t_{ACE}	\overline{CE} LOW to data valid	–	55	ns
t_{DOE}	\overline{OE} LOW to data valid	–	25	ns
t_{LZOE}	\overline{OE} LOW to low Z ^[17]	5	–	ns
t_{HZOE}	\overline{OE} HIGH to high Z ^[17, 18]	–	18	ns
t_{LZCE}	\overline{CE} LOW to low Z ^[17]	10	–	ns
t_{HZCE}	\overline{CE} HIGH to high Z ^[17, 18]	–	18	ns
t_{PU}	\overline{CE} LOW to power up	0	–	ns
t_{PD}	\overline{CE} HIGH to power down	–	55	ns
t_{DBE}	$\overline{BLE}/\overline{BHE}$ LOW to data valid	–	55	ns
t_{LZBE}	$\overline{BLE}/\overline{BHE}$ LOW to low Z ^[17]	10	–	ns
t_{HZBE}	$\overline{BLE}/\overline{BHE}$ HIGH to high Z ^[17, 18]	–	18	ns
Write Cycle ^[19]				
t_{WC}	Write cycle time	45	–	ns
t_{SCE}	\overline{CE} LOW to write end	35	–	ns
t_{AW}	Address setup to write end	35	–	ns
t_{HA}	Address hold from write end	0	–	ns
t_{SA}	Address setup to write start	0	–	ns
t_{PWE}	\overline{WE} pulse width	35	–	ns
t_{BW}	$\overline{BLE}/\overline{BHE}$ LOW to write end	35	–	ns
t_{SD}	Data setup to write end	25	–	ns
t_{HD}	Data hold from write end	0	–	ns
t_{HZWE}	\overline{WE} LOW to high Z ^[17, 18]	–	18	ns
t_{LZWE}	\overline{WE} HIGH to low Z ^[17]	10	–	ns

Notes

15. Test conditions for all parameters other than tri-state parameters assume signal transition time of 1V/ns or less, timing reference levels of $V_{CC(typ)}/2$, input pulse levels of 0 to $V_{CC(typ)}$, and output loading of the specified I_{OL}/I_{OH} as shown in the [Figure 2 on page 5](#).
16. In an earlier revision of this device, under a specific application condition, READ operations were limited to switching of the byte enable and/or chip enable signals as described in the Application Notes [AN13842](#) and [AN66311](#). However, the issue has been fixed and in production now, and hence, these Application Notes are no longer applicable. They are available for download on our website as they contain information on the date code of the parts, beyond which the fix has been in production.
17. At any given temperature and voltage condition, t_{HZCE} is less than t_{LZCE} , t_{HZBE} is less than t_{LZBE} , t_{HZOE} is less than t_{LZOE} , and t_{HZWE} is less than t_{LZWE} for any given device.
18. t_{HZOE} , t_{HZCE} , t_{HZBE} , and t_{HZWE} transitions are measured when the outputs enter a high impedance state
19. The internal write time of the memory is defined by the overlap of \overline{WE} , $\overline{CE} = V_{IL}$, \overline{BHE} and/or $\overline{BLE} = V_{IL}$. All signals must be ACTIVE to initiate a write and any of these signals can terminate a write by going INACTIVE. The data input setup and hold timing should be referenced to the edge of the signal that terminates the write.

Switching Waveforms

Figure 4. Read Cycle No.1 (Address Transition Controlled) [20, 21]

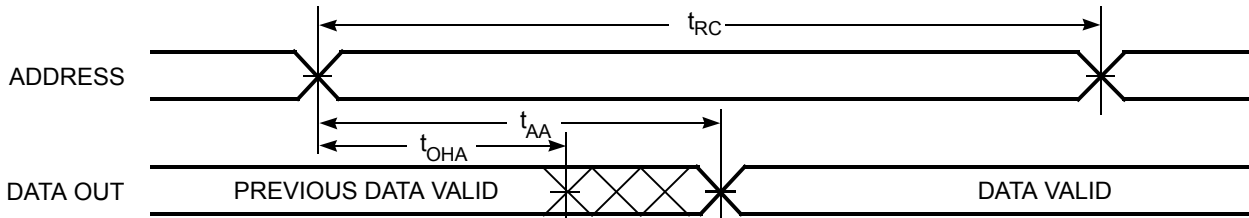
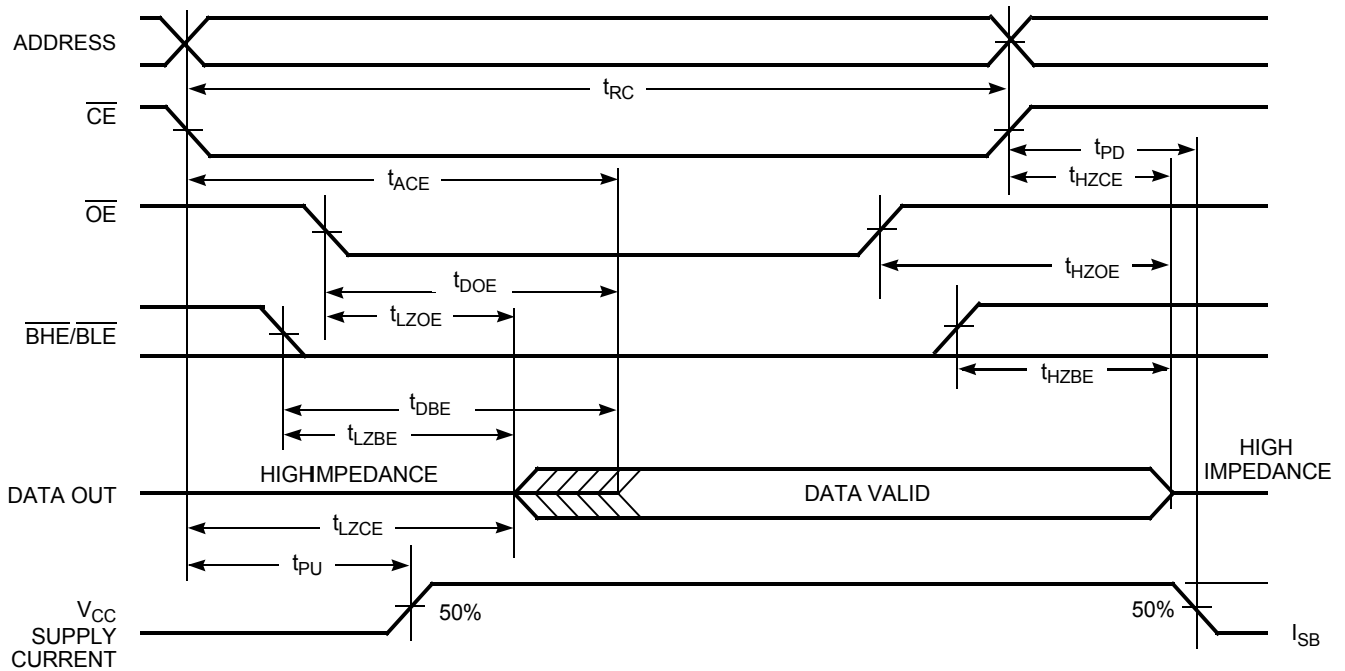

Figure 5. Read Cycle No. 2 (\overline{OE} Controlled) [21, 22]



Notes

- 20. The device is continuously selected. \overline{OE} , $\overline{CE} = V_{IL}$, \overline{BHE} and/or $\overline{BLE} = V_{IL}$.
- 21. \overline{WE} is HIGH for read cycle.
- 22. Address valid before or similar to \overline{CE} and \overline{BHE} , \overline{BLE} transition LOW.

Switching Waveforms (continued)

Figure 6. Write Cycle No. 1 (\overline{WE} Controlled) [23, 24]

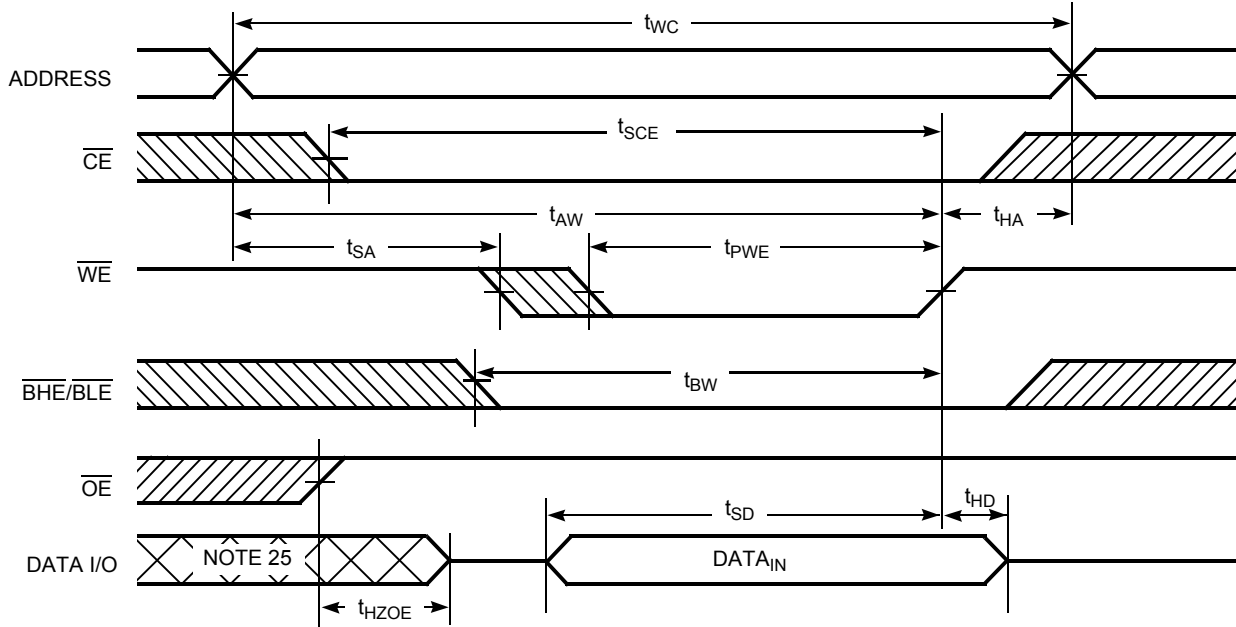
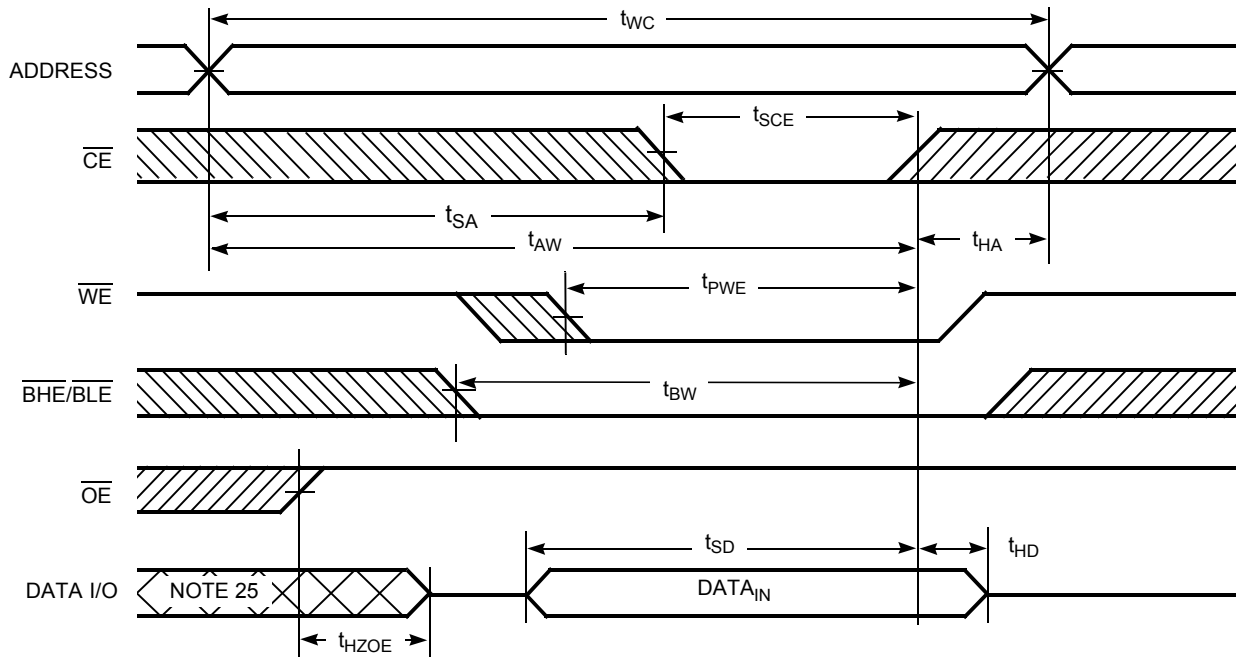

Figure 7. Write Cycle No. 2 (\overline{CE} Controlled) [23, 24]



Notes

- 23. Data I/O is high impedance if $\overline{OE} = V_{IH}$.
- 24. If \overline{CE} goes HIGH simultaneously with $\overline{WE} = V_{IH}$, the output remains in a high impedance state.
- 25. During this period, the I/Os are in output state. Do not apply input signals.

Switching Waveforms (continued)

Figure 8. Write Cycle No. 3 (\overline{WE} Controlled) [26]

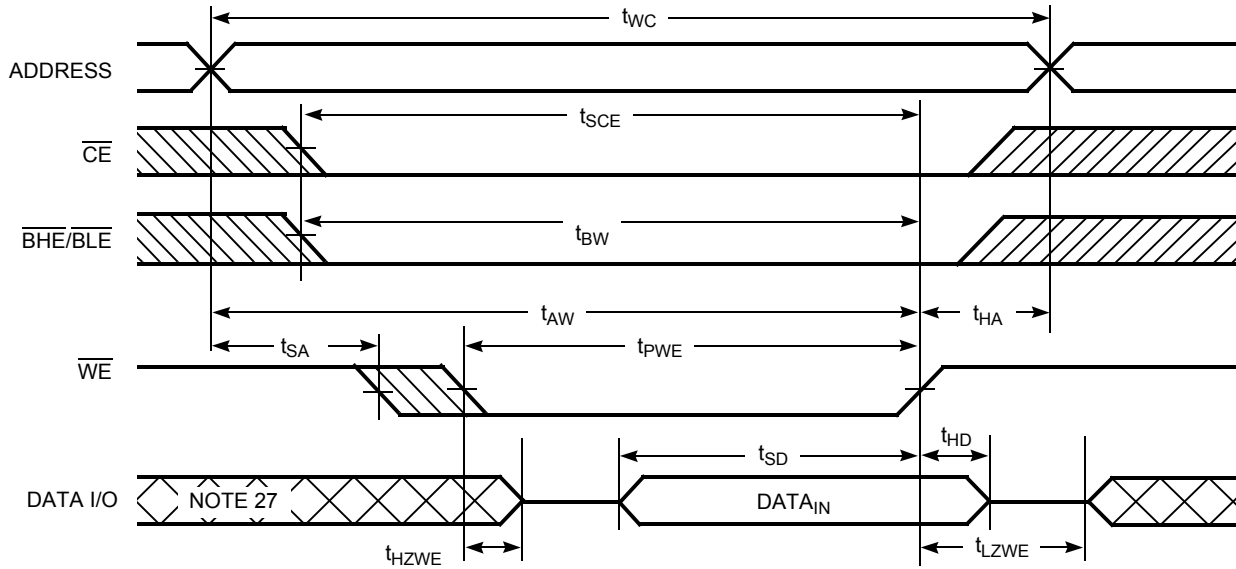
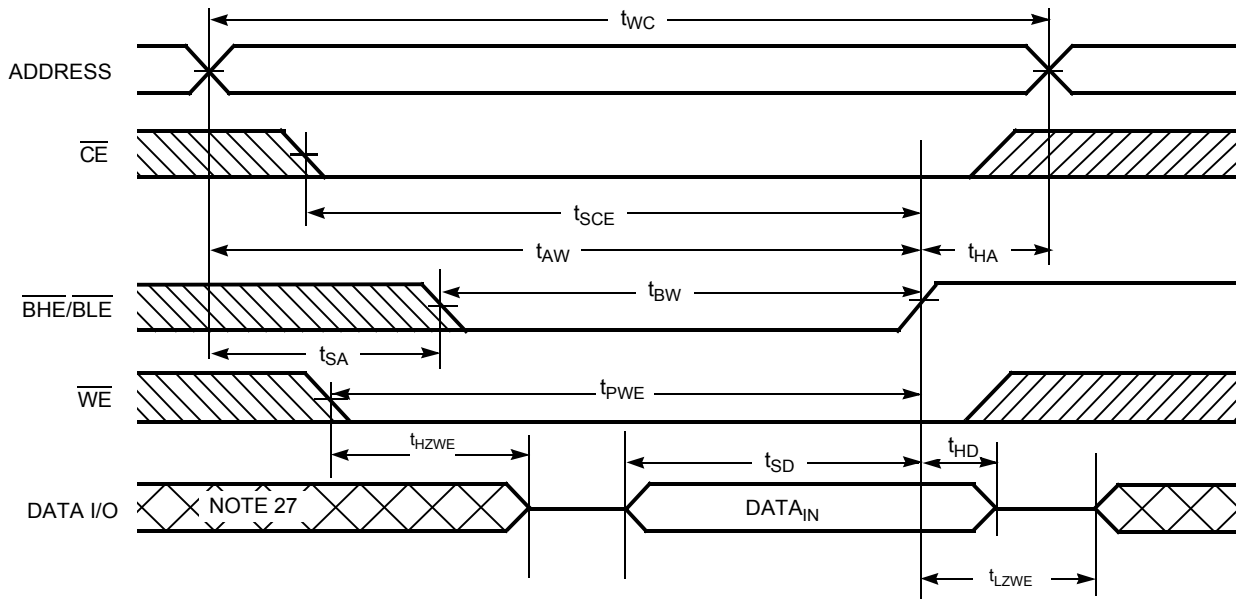

Figure 9. Write Cycle No. 4 (BHE/BL \overline{E} Controlled, \overline{OE} LOW) [26]



Notes

- 26. If \overline{CE} goes HIGH simultaneously with $\overline{WE} = V_{IH}$, the output remains in a high impedance state.
- 27. During this period, the I/Os are in output state. Do not apply input signals.

Truth Table

CE	WE	OE	BHE	BLE	Inputs or Outputs	Mode	Power
H	X	X	X ^[28]	X ^[28]	High Z	Deselect or power down	Standby (I _{SB})
X ^[28]	X	X	H	H	High Z	Deselect or power down	Standby (I _{SB})
L	H	L	L	L	Data out (I/O ₀ –I/O ₁₅)	Read	Active (I _{CC})
L	H	L	H	L	Data out (I/O ₀ –I/O ₇); I/O ₈ –I/O ₁₅ in High Z	Read	Active (I _{CC})
L	H	L	L	H	Data out (I/O ₈ –I/O ₁₅); I/O ₀ –I/O ₇ in High Z	Read	Active (I _{CC})
L	H	H	L	L	High Z	Output disabled	Active (I _{CC})
L	H	H	H	L	High Z	Output disabled	Active (I _{CC})
L	H	H	L	H	High Z	Output disabled	Active (I _{CC})
L	L	X	L	L	Data in (I/O ₀ –I/O ₁₅)	Write	Active (I _{CC})
L	L	X	H	L	Data in (I/O ₀ –I/O ₇); I/O ₈ –I/O ₁₅ in High Z	Write	Active (I _{CC})
L	L	X	L	H	Data in (I/O ₈ –I/O ₁₅); I/O ₀ –I/O ₇ in High Z	Write	Active (I _{CC})

Note

28. The 'X' (Don't care) state for the Chip enable ($\overline{\text{CE}}$) and Byte enables ($\overline{\text{BHE}}$ and $\overline{\text{BLE}}$) in the truth table refer to the logic state (either HIGH or LOW). Intermediate voltage levels on these pins is not permitted.

Ordering Information

Speed (ns)	Ordering Code	Package Diagram	Package Type	Operating Range
55	CY62137FV18LL-55BVXI	51-85150	48-ball VFPGA (Pb-free)	Industrial

Contact your local Cypress sales representative for availability of other parts.

Ordering Code Definitions

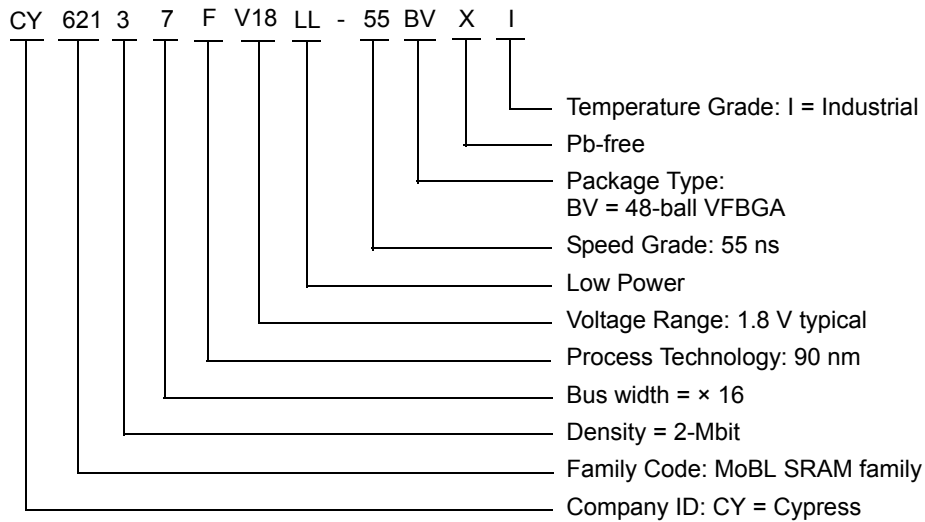

Package Diagram

Figure 10. 48-ball VFBGA (6 × 8 × 1 mm) BV48/BZ48 Package Outline, 51-85150

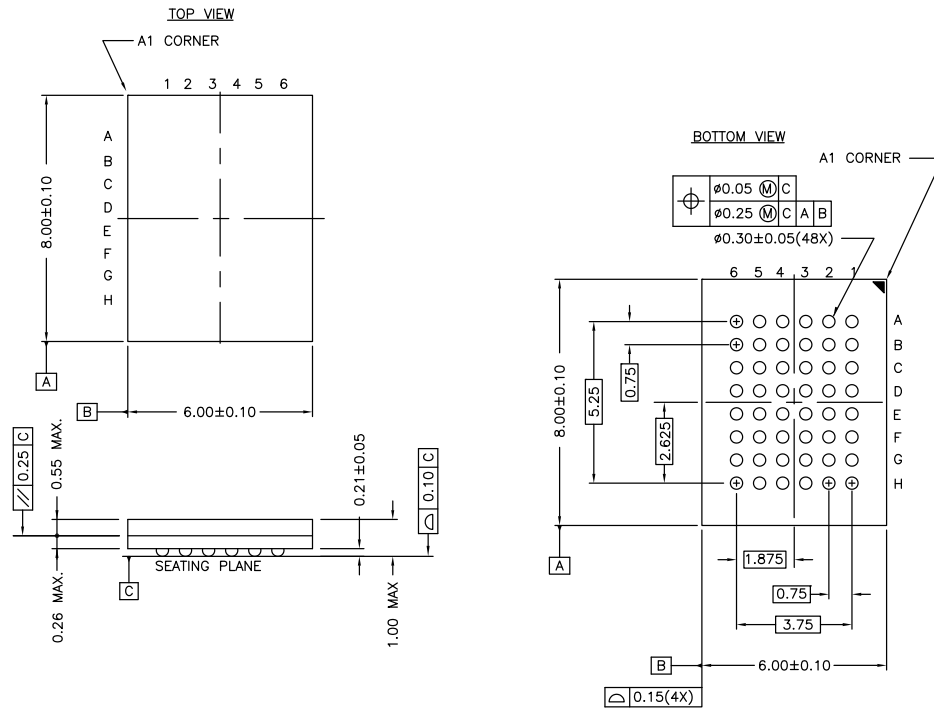

NOTE:
 PACKAGE WEIGHT: See Cypress Package Material Declaration Datasheet (PMDD)
 posted on the Cypress web.

51-85150 *H

Acronyms

Acronym	Description
$\overline{\text{BHE}}$	Byte High Enable
$\overline{\text{BLE}}$	Byte Low Enable
$\overline{\text{CE}}$	Chip Enable
CMOS	Complementary Metal Oxide Semiconductor
I/O	Input/Output
$\overline{\text{OE}}$	Output Enable
SRAM	Static Random Access Memory
VFBGA	Very Fine-Pitch Ball Grid Array
$\overline{\text{WE}}$	Write Enable

Document Conventions

Units of Measure

Symbol	Unit of Measure
°C	degree Celsius
MHz	megahertz
μA	microampere
μs	microsecond
mA	milliampere
mm	millimeter
ns	nanosecond
Ω	ohm
%	percent
pF	picofarad
V	volt
W	watt

Document History Page

Document Title: CY62137FV18 MoBL [®] , 2-Mbit (128 K × 16) Static RAM Document Number: 001-08030				
Rev.	ECN No.	Submission Date	Orig. of Change	Description of Change
**	463660	See ECN	NXR	New data sheet.
*A	469180	See ECN	NSI	Minor change: moved to external web
*B	569125	See ECN	NXR	Converted from preliminary to final Replaced 45 ns speed bin with 55 ns speed bin Changed the I _{CC(max)} value from 2.25 mA to 2.5 mA for test condition f=1 MHz Changed the I _{SB2(typ)} value from 0.5 μA to 1 μA Changed the I _{SB2(max)} value from 2.5 μA to 5 μA Changed the I _{CCDR(typ)} value from 0.5 μA to 1 μA and I _{CCDR(max)} value from 2.5 μA to 4 μA
*C	869500	See ECN	VKN	Added footnote #12 related to t _{ACE}
*D	908120	See ECN	VKN	Added footnote #8 related to I _{SB2} and I _{CCDR} Made footnote #13 applicable to AC parameters from t _{ACE} Changed t _{WC} specification from 45 ns to 55 ns Changed t _{SCE} , t _{AW} , t _{PWE} , t _{BW} specification from 35 ns to 40 ns Changed t _{HZWE} specification from 18 ns to 20 ns
*E	1274728	See ECN	VKN/AESA	Changed t _{WC} specification from 55 ns to 45 ns Changed t _{SCE} , t _{AW} , t _{PWE} , t _{BW} specification from 40 ns to 35 ns Changed t _{HZWE} specification from 20 ns to 18 ns
*F	2943752	06/03/2010	VKN	Added Contents Added footnote related to Chip enable and Byte enables in Truth Table Updated Package Diagram Added Sales, Solutions, and Legal Information
*G	3055165	10/12/2010	RAME	Added Contents Added Acronyms and Units of Measure Update Package Diagram from *E to *F Added Ordering Code Definitions details. Changed I _{SB1} /I _{SB2} /I _{CCDR} test conditions to reflect byte power down feature
*H	3061313	10/15/2010	RAME	Minor Changes: Corrected CE to \overline{CE} and WE to \overline{WE} in Figures 7 and 8
*I	3263825	06/17/2011	RAME	Replaced CE and OE with \overline{CE} and \overline{OE} in all instances in page 1. Updated Functional Description (Removed "For best practice recommendations, refer to the Cypress application note AN1064, SRAM System Guidelines.".) Updated in new template.
*J	4102185	08/22/2013	VINI	Updated Switching Characteristics : Updated Note 16. Updated Package Diagram : spec 51-85150 – Changed revision from *F to *H. Updated in new template.
*K	4208614	12/03/2013	MEMJ	Updated Features : Removed repeated instance of "Ultra low standby power". Completing Sunset Review.
*L	4574311	11/19/2014	MEMJ	Added related documentation hyperlink in page 1.
*M	5979573	11/29/2017	AESATMP8	Updated logo and Copyright.

Sales, Solutions, and Legal Information

Worldwide Sales and Design Support

Cypress maintains a worldwide network of offices, solution centers, manufacturer's representatives, and distributors. To find the office closest to you, visit us at [Cypress Locations](#).

Products

ARM [®] Cortex [®] Microcontrollers	cypress.com/arm
Automotive	cypress.com/automotive
Clocks & Buffers	cypress.com/clocks
Interface	cypress.com/interface
Internet of Things	cypress.com/iot
Memory	cypress.com/memory
Microcontrollers	cypress.com/mcu
PSoC	cypress.com/psoc
Power Management ICs	cypress.com/pmhc
Touch Sensing	cypress.com/touch
USB Controllers	cypress.com/usb
Wireless Connectivity	cypress.com/wireless

PSoC[®] Solutions

[PSoC 1](#) | [PSoC 3](#) | [PSoC 4](#) | [PSoC 5LP](#) | [PSoC 6](#)

Cypress Developer Community

[Forums](#) | [WICED IOT Forums](#) | [Projects](#) | [Video](#) | [Blogs](#) | [Training](#) | [Components](#)

Technical Support

cypress.com/support

© Cypress Semiconductor Corporation, 2006-2017. This document is the property of Cypress Semiconductor Corporation and its subsidiaries, including Spansion LLC ("Cypress"). This document, including any software or firmware included or referenced in this document ("Software"), is owned by Cypress under the intellectual property laws and treaties of the United States and other countries worldwide. Cypress reserves all rights under such laws and treaties and does not, except as specifically stated in this paragraph, grant any license under its patents, copyrights, trademarks, or other intellectual property rights. If the Software is not accompanied by a license agreement and you do not otherwise have a written agreement with Cypress governing the use of the Software, then Cypress hereby grants you a personal, non-exclusive, nontransferable license (without the right to sublicense) (1) under its copyright rights in the Software (a) for Software provided in source code form, to modify and reproduce the Software solely for use with Cypress hardware products, only internally within your organization, and (b) to distribute the Software in binary code form externally to end users (either directly or indirectly through resellers and distributors), solely for use on Cypress hardware product units, and (2) under those claims of Cypress's patents that are infringed by the Software (as provided by Cypress, unmodified) to make, use, distribute, and import the Software solely for use with Cypress hardware products. Any other use, reproduction, modification, translation, or compilation of the Software is prohibited.

TO THE EXTENT PERMITTED BY APPLICABLE LAW, CYPRESS MAKES NO WARRANTY OF ANY KIND, EXPRESS OR IMPLIED, WITH REGARD TO THIS DOCUMENT OR ANY SOFTWARE OR ACCOMPANYING HARDWARE, INCLUDING, BUT NOT LIMITED TO, THE IMPLIED WARRANTIES OF MERCHANTABILITY AND FITNESS FOR A PARTICULAR PURPOSE. To the extent permitted by applicable law, Cypress reserves the right to make changes to this document without further notice. Cypress does not assume any liability arising out of the application or use of any product or circuit described in this document. Any information provided in this document, including any sample design information or programming code, is provided only for reference purposes. It is the responsibility of the user of this document to properly design, program, and test the functionality and safety of any application made of this information and any resulting product. Cypress products are not designed, intended, or authorized for use as critical components in systems designed or intended for the operation of weapons, weapons systems, nuclear installations, life-support devices or systems, other medical devices or systems (including resuscitation equipment and surgical implants), pollution control or hazardous substances management, or other uses where the failure of the device or system could cause personal injury, death, or property damage ("Unintended Uses"). A critical component is any component of a device or system whose failure to perform can be reasonably expected to cause the failure of the device or system, or to affect its safety or effectiveness. Cypress is not liable, in whole or in part, and you shall and hereby do release Cypress from any claim, damage, or other liability arising from or related to all Unintended Uses of Cypress products. You shall indemnify and hold Cypress harmless from and against all claims, costs, damages, and other liabilities, including claims for personal injury or death, arising from or related to any Unintended Uses of Cypress products.

Cypress, the Cypress logo, Spansion, the Spansion logo, and combinations thereof, WICED, PSoC, CapSense, EZ-USB, F-RAM, and Traveo are trademarks or registered trademarks of Cypress in the United States and other countries. For a more complete list of Cypress trademarks, visit cypress.com. Other names and brands may be claimed as property of their respective owners.

X-ON Electronics

Largest Supplier of Electrical and Electronic Components

Click to view similar products for [SRAM](#) category:

Click to view products by [Cypress](#) manufacturer:

Other Similar products are found below :

[CY6116A-35DMB](#) [CY7C1049GN-10VXI](#) [CY7C128A-45DMB](#) [GS8161Z36DD-200I](#) [GS88237CB-200I](#) [RMLV0408EGSB-4S2#AA0](#)
[IDT70V5388S166BG](#) [IS64WV3216BLL-15CTLA3](#) [IS66WVE4M16ECLL-70BLI](#) [PCF8570P](#) [K6F2008V2E-LF70000](#) [K6T4008C1B-GB70](#)
[CY7C1353S-100AXC](#) [AS6C8016-55BIN](#) [AS7C164A-15PCN](#) [515712X](#) [IDT71V67603S133BG](#) [IS62WV51216EBLL-45BLI](#)
[IS63WV1288DBLL-10HLI](#) [IS66WVE2M16ECLL-70BLI](#) [IS66WVE4M16EALL-70BLI](#) [IS61WV102416DBLL-10TLI](#) [CY7C1381KV33-](#)
[100AXC](#) [CY7C1381KVE33-133AXI](#) [8602501XA](#) [5962-3829425MUA](#) [5962-3829430MUA](#) [5962-8855206YA](#) [5962-8866201YA](#) [5962-](#)
[8866204TA](#) [5962-8866206MA](#) [5962-8866208UA](#) [5962-8872502XA](#) [5962-9062007MXA](#) [5962-9161705MXA](#) [GS882Z18CD-150I](#)
[M38510/28902BVA](#) [8413202RA](#) [5962-9161708MYA](#) [5962-8971203XA](#) [5962-8971202ZA](#) [5962-8872501LA](#) [5962-8866208YA](#) [5962-](#)
[8866205YA](#) [5962-8866205UA](#) [5962-8866203YA](#) [5962-8855202YA](#) [5962-8751309VA](#) [5962-8687519XA](#) [IS61WV102416DBLL-10BLI](#)