

8-Mbit (1M words × 8-bit) Static RAM with Error-Correcting Code (ECC)

Features

- Ultra-low standby power
 - Typical standby current: 5.5 μ A
 - Maximum standby current: 16 μ A
- High speed: 45 ns
- Embedded error-correcting code (ECC) for single-bit error correction^[1, 2]
- Operating voltage range: 4.5 V to 5.5 V
- 1.0-V data retention
- Transistor-transistor logic (TTL) compatible inputs and outputs
- Available in Pb-free 44-pin TSOP II package

Functional Description

CY62158H is a high-performance CMOS low-power (MoBL) SRAM device with embedded ECC.

Device is accessed by asserting both chip enable inputs – \overline{CE}_1 as LOW and CE_2 as HIGH.

Write to the device is performed by taking Chip Enable 1 (\overline{CE}_1) LOW and Chip Enable 2 (CE_2) HIGH and the Write Enable (\overline{WE}) input LOW. Data on the eight I/O pins (I/O_0 through I/O_7) is then written into the location specified on the address pins (A_0 through A_{19}).

Read from the device is performed by taking Chip Enable 1 (\overline{CE}_1) and Output Enable (\overline{OE}) LOW and Chip Enable 2 (CE_2) HIGH while forcing Write Enable (\overline{WE}) HIGH. Under these conditions, the contents of the memory location specified by the address pins will appear on the I/O pins.

The eight input and output pins (I/O_0 through I/O_7) are placed in a high-impedance state when the device is deselected (\overline{CE}_1 HIGH or CE_2 LOW), the outputs are disabled (\overline{OE} HIGH), or a write operation is in progress (\overline{CE}_1 LOW and CE_2 HIGH and \overline{WE} LOW). See the [Truth Table – CY62158H](#) on page 11 for a complete description of read and write modes.

Logic Block Diagram – CY62158H

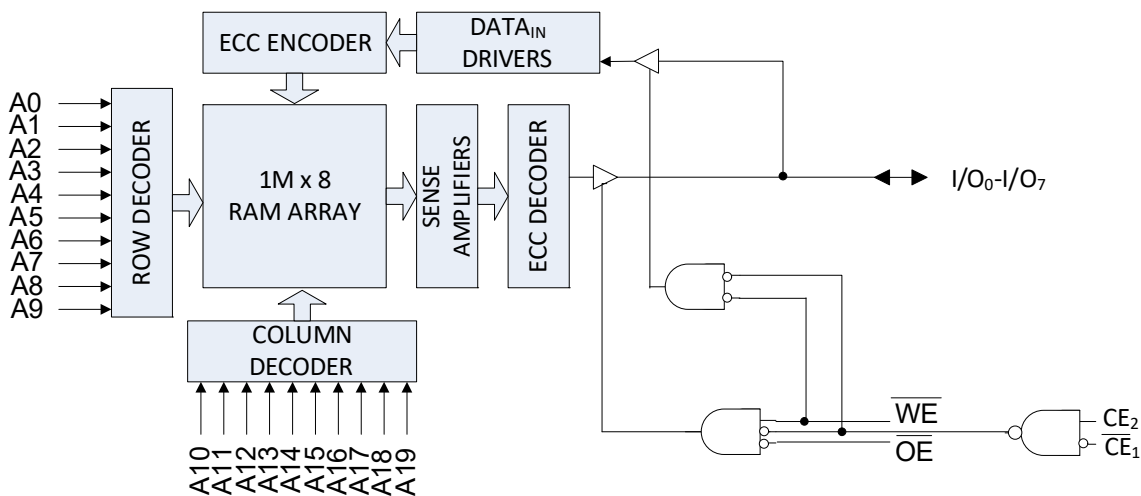

Notes

1. This device does not support automatic write-back on error detection.
2. SER FIT Rate <0.1 FIT/Mb. Refer [AN88889](#) for details.

Contents

Product Portfolio	3	Ordering Information	12
Pin Configurations – CY62158H	3	Ordering Code Definitions	12
Maximum Ratings	4	Package Diagram	13
Operating Range	4	Acronyms	14
DC Electrical Characteristics	4	Document Conventions	14
Capacitance	5	Units of Measure	14
Thermal Resistance	5	Document History Page	15
AC Test Loads and Waveforms	5	Sales, Solutions, and Legal Information	16
Data Retention Characteristics	6	Worldwide Sales and Design Support	16
Data Retention Waveform	6	Products	16
Switching Characteristics	7	PSoC [®] Solutions	16
Switching Waveforms	8	Cypress Developer Community	16
Truth Table – CY62158H	11	Technical Support	16

Product Portfolio

Product	Features and Options (see Pin Configurations – CY62158H)	Range	V _{CC} Range (V)	Speed (ns)	Power Dissipation			
					Operating I _{CC} (mA)		Standby I _{SB2} (μA)	
					f = f _{max}			
					Typ ^[3]	Max	Typ ^[3]	Max
CY62158H	Dual Chip Enable	Industrial	4.5 V–5.5 V	45	29	36	5.5	16

Pin Configurations – CY62158H

Figure 1. 44-pin TSOP II Pinout ^[4]

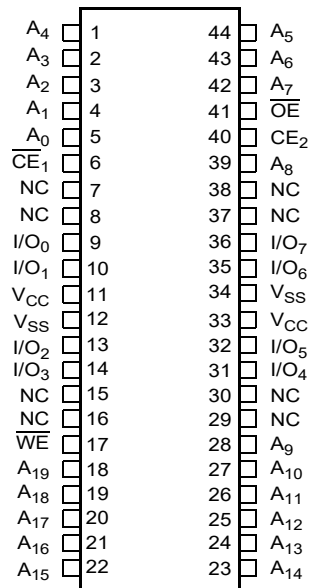

Notes

- Typical values are included for reference only and are not guaranteed or tested. Typical values are measured at V_{CC} = 5 V (for V_{CC} range of 4.5 V–5.5 V), T_A = 25 °C.
- NC pins are not connected internally to the die and are typically used for address expansion to a higher-density device. Refer to the respective datasheets for pin configuration.

Maximum Ratings

Exceeding maximum ratings may shorten the useful life of the device. User guidelines are not tested.

Storage temperature	-65 °C to + 150 °C
Ambient temperature with power applied	-55 °C to + 125 °C
Supply voltage to ground potential	-0.5 V to $V_{CC} + 0.5$ V
DC voltage applied to outputs in High Z state ^[5]	-0.5 V to $V_{CC} + 0.5$ V

DC input voltage ^[5]	-0.5 V to $V_{CC} + 0.5$ V
Output current into outputs (LOW)	20 mA
Static discharge voltage (MIL-STD-883, Method 3015)	>2001 V
Latch-up current	>140 mA

Operating Range

Grade	Ambient Temperature	V_{CC} ^[6]
Industrial	-40 °C to +85 °C	4.5 V to 5.5 V

DC Electrical Characteristics

Over the Operating Range of -40 °C to 85 °C

Parameter	Description		Test Conditions	45 ns			Unit
				Min	Typ ^[7]	Max	
V_{OH}	Output HIGH voltage	4.5 V to 5.5 V	$V_{CC} = \text{Min}, I_{OH} = -1.0$ mA	2.4	-	-	V
		4.5 V to 5.5 V	$V_{CC} = \text{Min}, I_{OH} = -0.1$ mA	$V_{CC} - 0.4$ ^[8]	-	-	
V_{OL}	Output LOW voltage	4.5 V to 5.5 V	$V_{CC} = \text{Min}, I_{OL} = 2.1$ mA	-	-	0.4	V
V_{IH} ^[5]	Input HIGH voltage	4.5 V to 5.5 V	-	2.2	-	$V_{CC} + 0.5$	V
V_{IL} ^[5]	Input LOW voltage	4.5 V to 5.5 V	-	-0.5	-	0.8	V
I_{IX}	Input leakage current	$GND \leq V_{IN} \leq V_{CC}$		-1.0	-	+1.0	μ A
I_{OZ}	Output leakage current	$GND \leq V_{OUT} \leq V_{CC}$, Output disabled		-1.0	-	+1.0	μ A
I_{CC}	V_{CC} operating supply current	$V_{CC} = \text{Max}, I_{OUT} = 0$ mA, CMOS levels	$f = 22.22$ MHz (45 ns)	-	29.0	36.0	mA
			$f = 1$ MHz	-	7.0	9.0	
I_{SB1} ^[9]	Automatic power down current – CMOS inputs; $V_{CC} = 4.5$ to 5.5 V	$\overline{CE}_1 \geq V_{CC} - 0.2$ V or $CE_2 \leq 0.2$ V, $V_{IN} \geq V_{CC} - 0.2$ V, $V_{IN} \leq 0.2$ V, $f = f_{\text{max}}$ (address and data only), $f = 0$ (\overline{OE} , and \overline{WE}), $V_{CC} = V_{CC(\text{max})}$		-	5.5	16.0	μ A
I_{SB2} ^[9]	Automatic power down current – CMOS inputs; $V_{CC} = 4.5$ to 5.5 V	$\overline{CE}_1 \geq V_{CC} - 0.2$ V or $CE_2 \leq 0.2$ V, or $V_{IN} \geq V_{CC} - 0.2$ V or $V_{IN} \leq 0.2$ V, $f = 0$, $V_{CC} = V_{CC(\text{max})}$	25 °C ^[10]	-	5.5	6.5	μ A
			40 °C ^[10]	-	6.3	8.0	
			70 °C ^[10]	-	8.4	12.0	
			85 °C	-	12.0 ^[10]	16.0	

Notes

- $V_{IL(\text{min})} = -2.0$ V and $V_{IH(\text{max})} = V_{CC} + 2$ V for pulse durations of less than 20 ns.
- Full Device AC operation assumes a 100 μ s ramp time from 0 to $V_{CC(\text{min})}$ and 200 μ s wait time after V_{CC} stabilization.
- Typical values are included for reference only and are not guaranteed or tested. Typical values are measured at $V_{CC} = 5$ V (for V_{CC} range of 4.5 V–5.5 V), $T_A = 25$ °C.
- This parameter is guaranteed by design and not tested.
- Chip enables (\overline{CE}_1 and CE_2) must be tied to CMOS levels to meet the $I_{SB1} / I_{SB2} / I_{CCDR}$ spec. Other inputs can be left floating.
- The I_{SB2} limits at 25 °C, 40 °C, 70 °C and typical limit at 85 °C are guaranteed by design and not 100% tested.

Capacitance

Parameter ^[11]	Description	Test Conditions	Max	Unit
C _{IN}	Input capacitance	T _A = 25 °C, f = 1 MHz, V _{CC} = V _{CC(typ)}	10	pF
C _{OUT}	Output capacitance		10	pF

Thermal Resistance

Parameter ^[11]	Description	Test Conditions	44-pin TSOP II	Unit
θ _{JA}	Thermal resistance (junction to ambient)	Still air, soldered on a 3 × 4.5 inch, four-layer printed circuit board	66.93	°C/W
θ _{JC}	Thermal resistance (junction to case)		13.09	°C/W

AC Test Loads and Waveforms

Figure 2. AC Test Loads and Waveforms

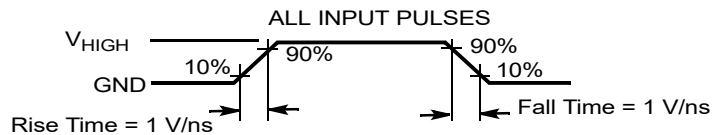
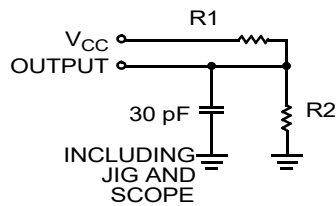

Equivalent to: THÉVENIN EQUIVALENT

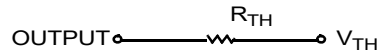

Parameters	5.0 V	Unit
R1	1800	Ω
R2	990	Ω
R _{TH}	639	Ω
V _{TH}	1.77	V
V _{HIGH}	5.0	V

Note

11. Tested initially and after any design or process changes that may affect these parameters.

Data Retention Characteristics

Over the Operating Range

Parameter	Description	Conditions	Min	Typ ^[12]	Max	Unit
V_{DR}	V_{CC} for data retention		1.0	–	–	V
I_{CCDR} ^[13, 14]	Data retention current	$1.2\text{ V} \leq V_{CC} \leq 2.2\text{ V}$, $\overline{CE}_1 \geq V_{CC} - 0.2\text{ V}$ or $CE_2 \leq 0.2\text{ V}$, $V_{IN} \geq V_{CC} - 0.2\text{ V}$ or $V_{IN} \leq 0.2\text{ V}$	–	7.0	26.0	μA
		$2.2\text{ V} < V_{CC} \leq 3.6\text{ V}$ or $4.5\text{ V} \leq V_{CC} \leq 5.5\text{ V}$, $\overline{CE}_1 \geq V_{CC} - 0.2\text{ V}$ or $CE_2 \leq 0.2\text{ V}$, $V_{IN} \geq V_{CC} - 0.2\text{ V}$ or $V_{IN} \leq 0.2\text{ V}$	–	5.5	16.0	μA
t_{CDR} ^[15]	Chip deselect to data retention time		0	–	–	–
t_R ^[15, 16]	Operation recovery time		45	–	–	ns

Data Retention Waveform

Figure 3. Data Retention Waveform

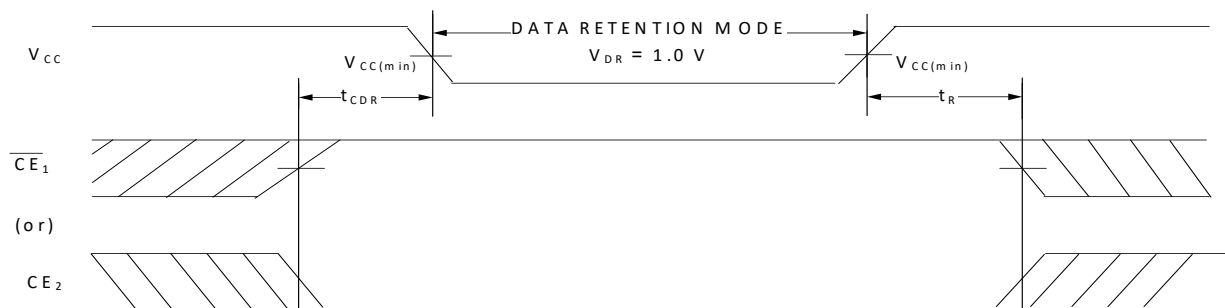

Notes

12. Typical values are included for reference only and are not guaranteed or tested. Typical values are measured at $V_{CC} = 1.8\text{ V}$ (for V_{CC} range of 1.65 V–2.2 V), $V_{CC} = 3\text{ V}$ (for V_{CC} range of 2.2 V–3.6 V), and $V_{CC} = 5\text{ V}$ (for V_{CC} range of 4.5 V–5.5 V), $T_A = 25\text{ }^\circ\text{C}$.
13. Chip enables (\overline{CE}_1 and CE_2) must be tied to CMOS levels to meet the I_{SB1} / I_{SB2} / I_{CCDR} spec. Other inputs can be left floating.
14. I_{CCDR} is guaranteed only after device is first powered up to $V_{CC(\text{min})}$ and brought down to V_{DR} .
15. These parameters are guaranteed by design.
16. Full device operation requires linear V_{CC} ramp from V_{DR} to $V_{CC(\text{min})} \geq 100\text{ }\mu\text{s}$ or stable at $V_{CC(\text{min})} \geq 100\text{ }\mu\text{s}$.

Switching Characteristics

Parameter ^[17]	Description	45 ns		Unit
		Min	Max	
Read Cycle				
t_{RC}	Read cycle time	45.0	–	ns
t_{AA}	Address to data valid	–	45.0	ns
t_{OHA}	Data hold from address change	10.0	–	ns
t_{ACE}	\overline{CE}_1 LOW and CE_2 HIGH to data valid / \overline{CE} LOW to ERR valid	–	45.0	ns
t_{DOE}	\overline{OE} LOW to data valid / \overline{OE} LOW to ERR valid	–	22.0	ns
t_{LZOE}	\overline{OE} LOW to Low Z ^[18, 19, 20]	5.0	–	ns
t_{HZOE}	\overline{OE} HIGH to High Z ^[18, 19, 20, 21]	–	18.0	ns
t_{LZCE}	\overline{CE}_1 LOW and CE_2 HIGH to Low Z ^[18, 19, 20]	10.0	–	ns
t_{HZCE}	\overline{CE}_1 HIGH and CE_2 LOW to High Z ^[18, 19, 20, 21]	–	18.0	ns
t_{PU}	\overline{CE}_1 LOW and CE_2 HIGH to power-up ^[20]	0	–	ns
t_{PD}	\overline{CE}_1 HIGH and CE_2 LOW to power-down ^[20]	–	45.0	ns
Write Cycle^[22, 23]				
t_{WC}	Write cycle time	45.0	–	ns
t_{SCE}	\overline{CE}_1 LOW and CE_2 HIGH to write end	35.0	–	ns
t_{AW}	Address setup to write end	35.0	–	ns
t_{HA}	Address hold from write end	0	–	ns
t_{SA}	Address setup to write start	0	–	ns
t_{PWE}	\overline{WE} pulse width	35.0	–	ns
t_{SD}	Data setup to write end	25.0	–	ns
t_{HD}	Data hold from write end	0	–	ns
t_{HZWE}	\overline{WE} LOW to High Z ^[18, 19, 20, 21]	–	18.0	ns
t_{LZWE}	\overline{WE} HIGH to Low Z ^[18, 19, 20]	10.0	–	ns

Notes

17. Test conditions assume signal transition time (rise/fall) of 3 ns or less, timing reference levels of 1.5 V (for $V_{CC} \geq 3$ V) and $V_{CC}/2$ (for $V_{CC} < 3$ V), and input pulse levels of 0 to 3 V (for $V_{CC} \geq 3$ V) and 0 to V_{CC} (for $V_{CC} < 3$ V). Test conditions for the read cycle use output loading shown in AC Test Loads and Waveforms section, unless specified otherwise.
18. At any temperature and voltage condition, t_{HZCE} is less than t_{LZCE} , t_{HZOE} is less than t_{LZOE} , and t_{HZWE} is less than t_{LZWE} for any device.
19. Tested initially and after any design or process changes that may affect these parameters.
20. These parameters are guaranteed by design and are not tested.
21. t_{HZOE} , t_{HZCE} , and t_{HZWE} transitions are measured when the outputs enter a high impedance state.
22. The internal write time of the memory is defined by the overlap of $\overline{WE} = V_{IL}$, $\overline{CE}_1 = V_{IL}$, and $CE_2 = V_{IH}$. All signals must be ACTIVE to initiate a write and any of these signals can terminate a write by going INACTIVE. The data input setup and hold timing must refer to the edge of the signal that terminates the write.
23. The minimum write cycle pulse width for Write cycle No. 2 (\overline{WE} Controlled, \overline{OE} Low) should be equal to the sum of t_{HZWE} and t_{SD} .

Switching Waveforms

Figure 4. Read Cycle No. 1 (Address Transition Controlled)^[24, 25]

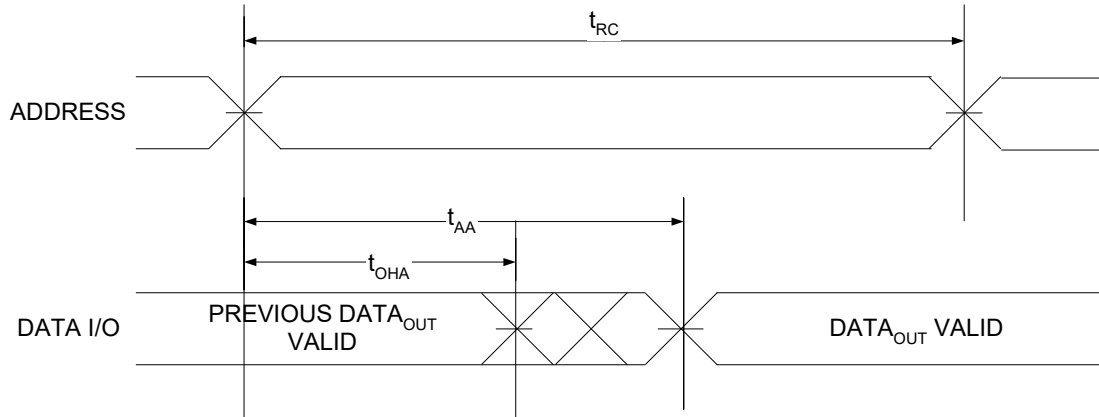
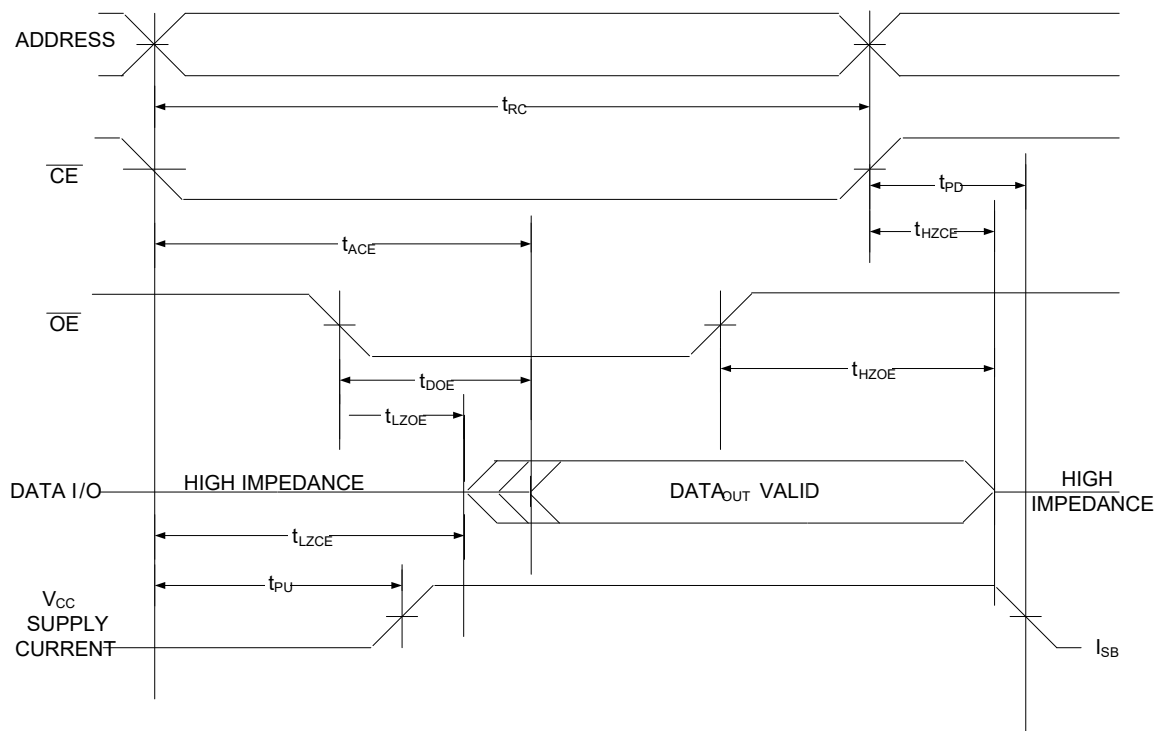

Figure 5. Read Cycle No. 2 (\overline{OE} Controlled)^[25, 26, 27]



Notes

24. The device is continuously selected. $\overline{OE} = V_{IL}$, $\overline{CE} = V_{IL}$.

25. \overline{WE} is HIGH for read cycle.

26. For all dual chip enable devices, \overline{CE} is the logical combination of \overline{CE}_1 and CE_2 . When \overline{CE}_1 is LOW and CE_2 is HIGH, \overline{CE} is LOW; when \overline{CE}_1 is HIGH or CE_2 is LOW, \overline{CE} is HIGH.

27. Address valid prior to or coincident with \overline{CE} LOW transition.

Switching Waveforms (continued)

Figure 6. Write Cycle No. 1 (\overline{WE} Controlled)^[28, 29, 30]

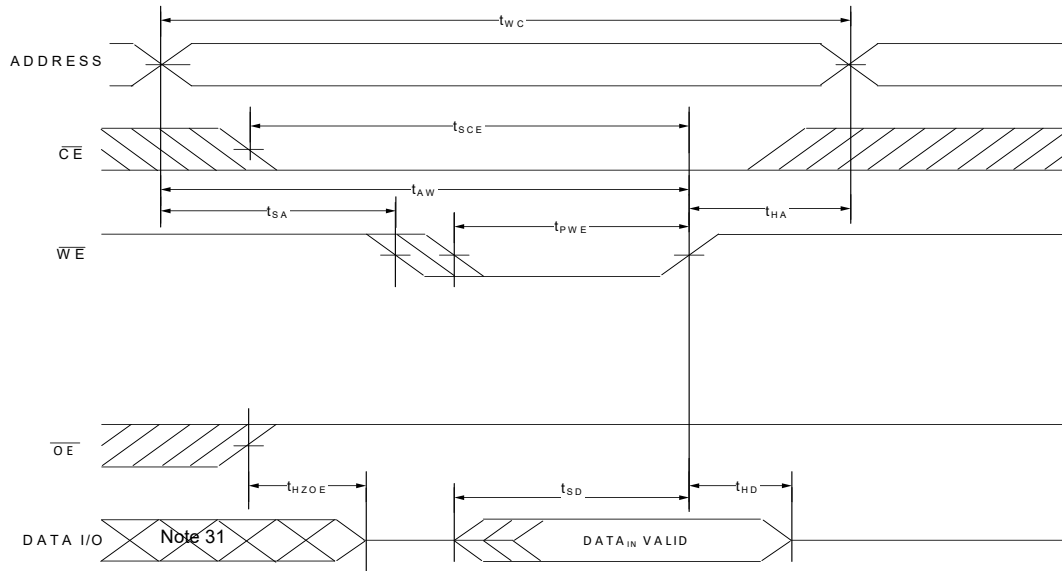

Notes

- 28. For all dual chip enable devices, \overline{CE} is the logical combination of \overline{CE}_1 and CE_2 . When \overline{CE}_1 is LOW and CE_2 is HIGH, \overline{CE} is LOW; when \overline{CE}_1 is HIGH or CE_2 is LOW, \overline{CE} is HIGH.
- 29. The internal write time of the memory is defined by the overlap of $\overline{WE} = V_{IL}$, $\overline{CE}_1 = V_{IL}$, and $CE_2 = V_{IH}$. All signals must be ACTIVE to initiate a write and any of these signals can terminate a write by going INACTIVE. The data input setup and hold timing must refer to the edge of the signal that terminates the write.
- 30. Data I/O is in the high-impedance state if $\overline{CE} = V_{IH}$, or $\overline{OE} = V_{IH}$.
- 31. During this period, the I/Os are in output state. Do not apply input signals.

Switching Waveforms (continued)

Figure 7. Write Cycle No. 2 (\overline{WE} Controlled, \overline{OE} Low)^[32, 33, 34, 35]

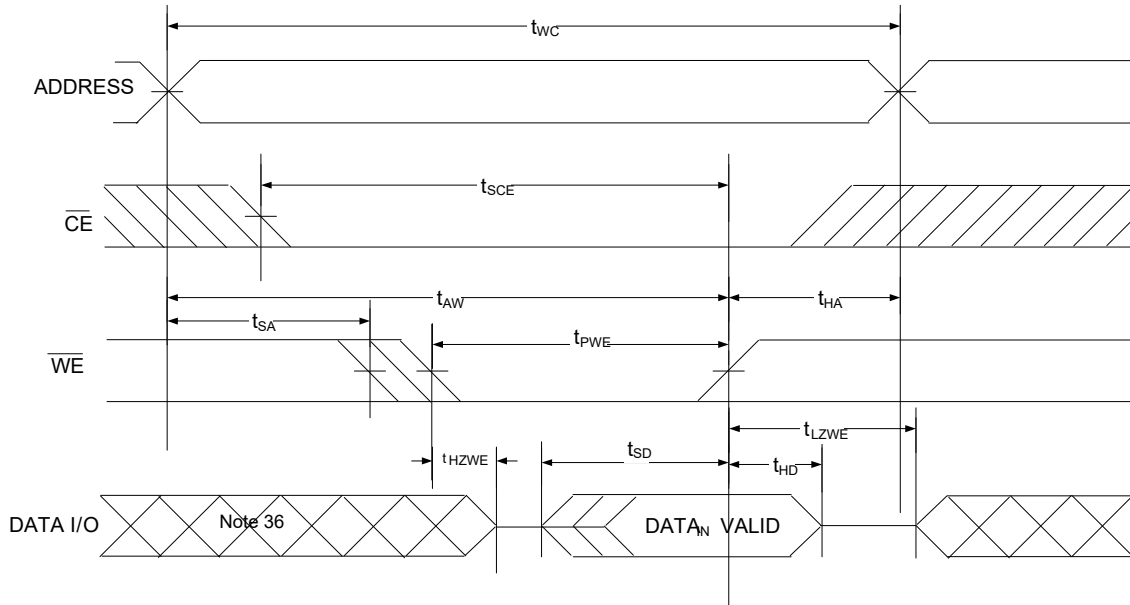
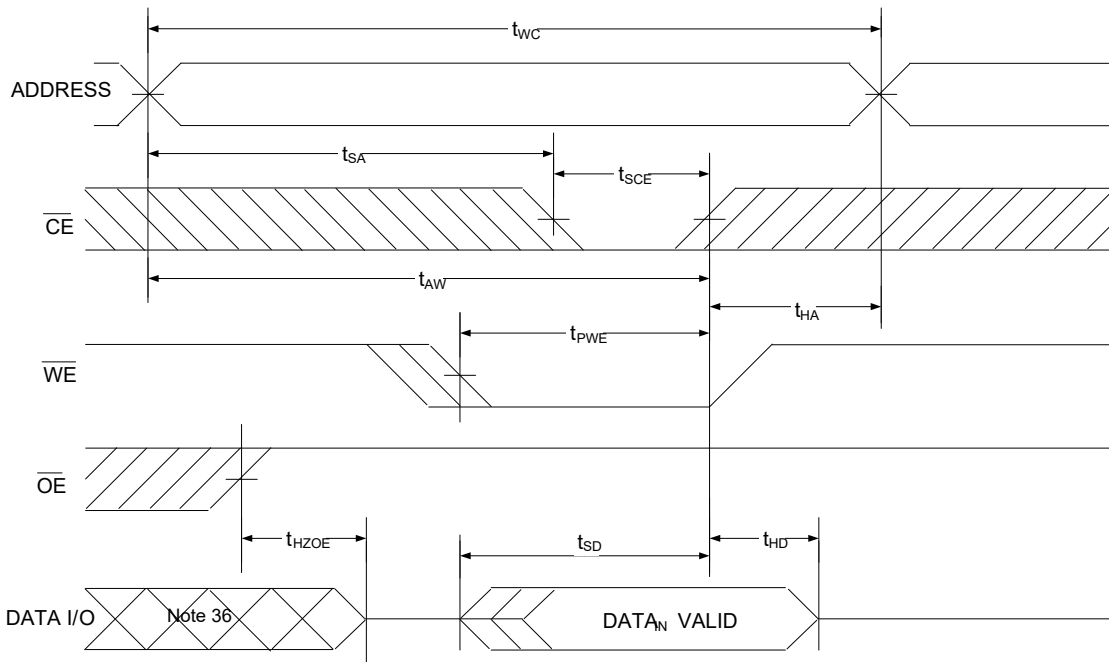

Figure 8. Write Cycle No. 3 (\overline{CE} Controlled)^[32, 33, 34]



Notes

- 32. For all dual chip enable devices, \overline{CE} is the logical combination of \overline{CE}_1 and CE_2 . When \overline{CE}_1 is LOW and CE_2 is HIGH, \overline{CE} is LOW; when \overline{CE}_1 is HIGH or CE_2 is LOW, \overline{CE} is HIGH.
- 33. The internal write time of the memory is defined by the overlap of $\overline{WE} = V_{IL}$, $\overline{CE}_1 = V_{IL}$, and $CE_2 = V_{IH}$. All signals must be ACTIVE to initiate a write and any of these signals can terminate a write by going INACTIVE. The data input setup and hold timing must refer to the edge of the signal that terminates the write.
- 34. Data I/O is in high impedance state if $\overline{CE} = V_{IH}$, or $\overline{OE} = V_{IH}$.
- 35. The minimum write cycle pulse width should be equal to the sum of the t_{HZWE} and t_{SD} .
- 36. During this period I/O are in the output state. Do not apply input signals.

Truth Table – CY62158H

\overline{CE}_1	CE_2	\overline{WE}	\overline{OE}	I/Os	Mode	Power
H	X ^[37]	X ^[37]	X ^[37]	High Z	Deselect / Power down	Standby (I _{SB2})
X ^[37]	L	X ^[37]	X ^[37]	High Z	Deselect / Power down	Standby (I _{SB2})
L	H	H	L	Data Out (I/O ₀ –I/O ₇)	Read	Active (I _{CC})
L	H	H	H	High Z	Output disabled	Active (I _{CC})
L	H	L	X	Data In (I/O ₀ –I/O ₇)	Write	Active (I _{CC})

Note

37. The 'X' (Don't care) state for the chip enables refer to the logic state (either HIGH or LOW). Intermediate voltage levels on these pins is not permitted.

Ordering Information

Speed (ns)	Ordering Code	Package Diagram	Package Type (all Pb-free)	Operating Range
45	CY62158H-45ZSXI	51-85087	44-pin TSOP II (Pb-free)	Industrial
	CY62158H-45ZSXIT			

Ordering Code Definitions

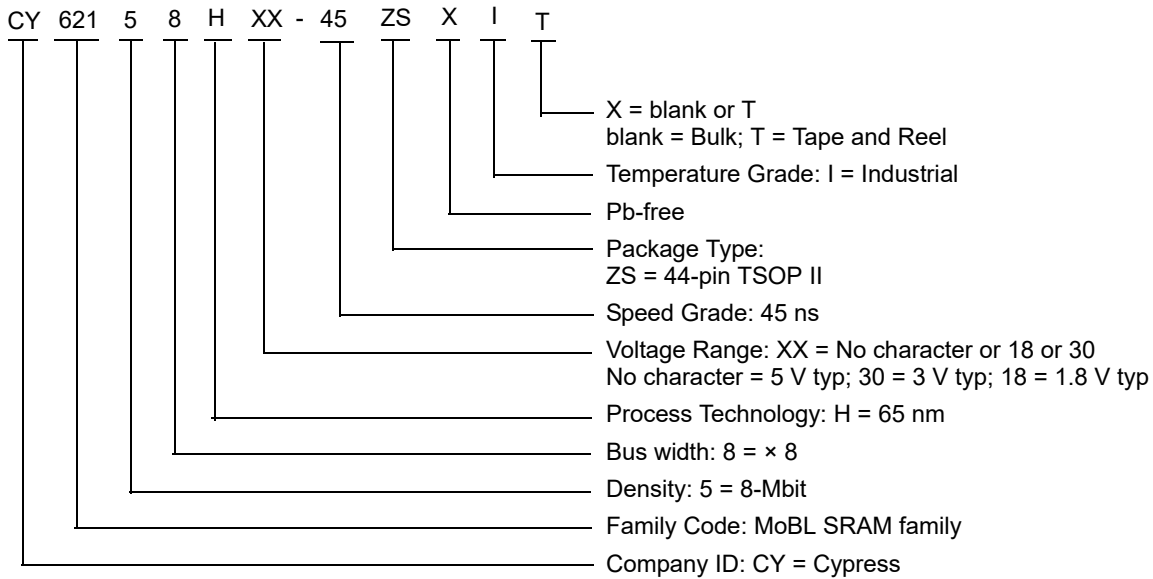

Package Diagram

Figure 9. 44-pin TSOP Z44-II Package Outline, 51-85087

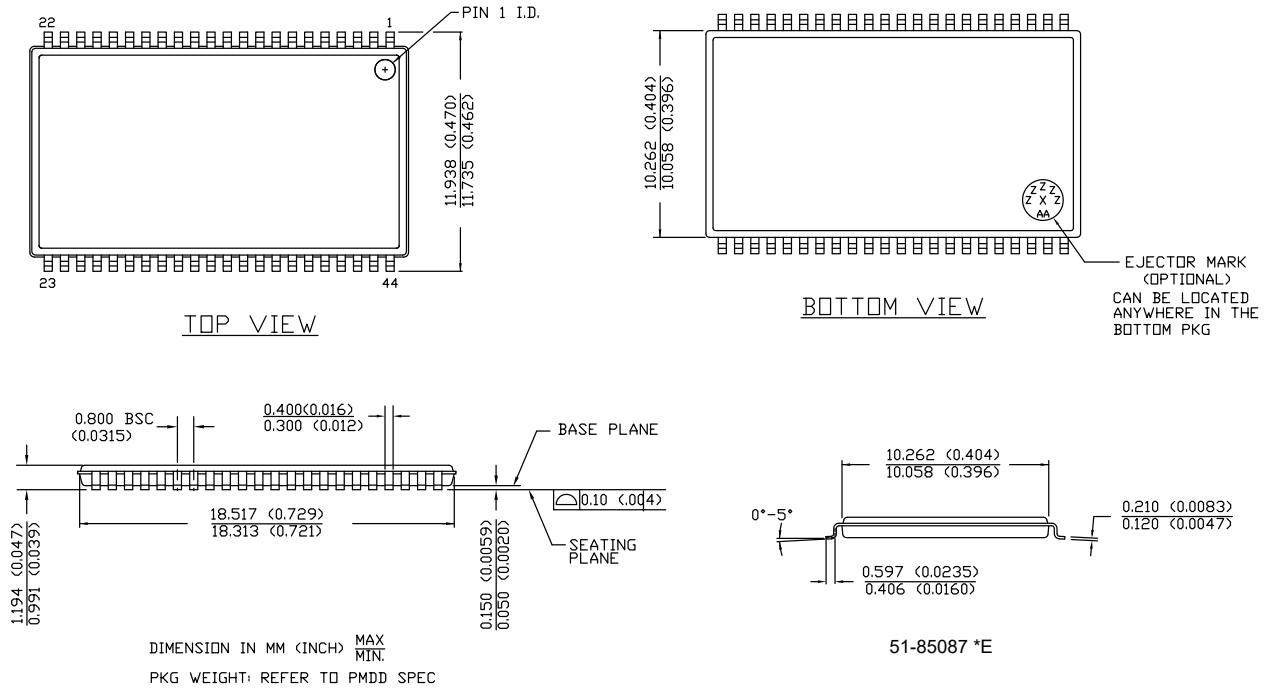

Acronyms

Table 1. Acronyms Used in this Document

Acronym	Description
CE	Chip Enable
CMOS	Complementary Metal Oxide Semiconductor
I/O	Input/Output
OE	Output Enable
SRAM	Static Random Access Memory
VFBGA	Very Fine-Pitch Ball Grid Array
WE	Write Enable
ECC	Error Correcting Code

Document Conventions

Units of Measure

Table 2. Units of Measure

Symbol	Unit of Measure
°C	degree Celsius
MHz	megahertz
μA	microampere
μs	microsecond
mA	milliampere
mm	millimeter
ns	nanosecond
Ω	ohm
%	percent
pF	picofarad
V	volt

Document History Page

Document Title: CY62158H MoBL [®] , 8-Mbit (1M words × 8-bit) Static RAM with Error-Correcting Code (ECC) Document Number: 001-96968				
Rev.	ECN No.	Orig. of Change	Submission Date	Description of Change
*B	5258628	NILE	05/06/2016	Changed status from Preliminary to Final.
*C	5430402	VINI	09/13/2016	Updated DC Electrical Characteristics : Updated Note 5 (Replaced 2 ns with 20 ns). Updated Ordering Information : Updated part numbers. Updated to new template.
*D	5980470	AESATMP8	11/30/2017	Updated logo and Copyright.
*E	6122301	NILE	04/04/2018	Updated Features : Referred Note 1 in “Embedded error-correcting code (ECC) for single-bit error correction”. Added Note 2 and referred the same note in “Embedded error-correcting code (ECC) for single-bit error correction”. Updated to new template. Completing Sunset Review.

Sales, Solutions, and Legal Information

Worldwide Sales and Design Support

Cypress maintains a worldwide network of offices, solution centers, manufacturer's representatives, and distributors. To find the office closest to you, visit us at [Cypress Locations](#).

Products

Arm [®] Cortex [®] Microcontrollers	cypress.com/arm
Automotive	cypress.com/automotive
Clocks & Buffers	cypress.com/clocks
Interface	cypress.com/interface
Internet of Things	cypress.com/iot
Memory	cypress.com/memory
Microcontrollers	cypress.com/mcu
PSoC	cypress.com/psoc
Power Management ICs	cypress.com/pmic
Touch Sensing	cypress.com/touch
USB Controllers	cypress.com/usb
Wireless Connectivity	cypress.com/wireless

PSoC[®] Solutions

[PSoC 1](#) | [PSoC 3](#) | [PSoC 4](#) | [PSoC 5LP](#) | [PSoC 6 MCU](#)

Cypress Developer Community

[Community](#) | [Projects](#) | [Video](#) | [Blogs](#) | [Training](#) | [Components](#)

Technical Support

cypress.com/support

© Cypress Semiconductor Corporation, 2015-2018. This document is the property of Cypress Semiconductor Corporation and its subsidiaries, including Spansion LLC ("Cypress"). This document, including any software or firmware included or referenced in this document ("Software"), is owned by Cypress under the intellectual property laws and treaties of the United States and other countries worldwide. Cypress reserves all rights under such laws and treaties and does not, except as specifically stated in this paragraph, grant any license under its patents, copyrights, trademarks, or other intellectual property rights. If the Software is not accompanied by a license agreement and you do not otherwise have a written agreement with Cypress governing the use of the Software, then Cypress hereby grants you a personal, non-exclusive, nontransferable license (without the right to sublicense) (1) under its copyright rights in the Software (a) for Software provided in source code form, to modify and reproduce the Software solely for use with Cypress hardware products, only internally within your organization, and (b) to distribute the Software in binary code form externally to end users (either directly or indirectly through resellers and distributors), solely for use on Cypress hardware product units, and (2) under those claims of Cypress's patents that are infringed by the Software (as provided by Cypress, unmodified) to make, use, distribute, and import the Software solely for use with Cypress hardware products. Any other use, reproduction, modification, translation, or compilation of the Software is prohibited.

TO THE EXTENT PERMITTED BY APPLICABLE LAW, CYPRESS MAKES NO WARRANTY OF ANY KIND, EXPRESS OR IMPLIED, WITH REGARD TO THIS DOCUMENT OR ANY SOFTWARE OR ACCOMPANYING HARDWARE, INCLUDING, BUT NOT LIMITED TO, THE IMPLIED WARRANTIES OF MERCHANTABILITY AND FITNESS FOR A PARTICULAR PURPOSE. To the extent permitted by applicable law, Cypress reserves the right to make changes to this document without further notice. Cypress does not assume any liability arising out of the application or use of any product or circuit described in this document. Any information provided in this document, including any sample design information or programming code, is provided only for reference purposes. It is the responsibility of the user of this document to properly design, program, and test the functionality and safety of any application made of this information and any resulting product. Cypress products are not designed, intended, or authorized for use as critical components in systems designed or intended for the operation of weapons, weapons systems, nuclear installations, life-support devices or systems, other medical devices or systems (including resuscitation equipment and surgical implants), pollution control or hazardous substances management, or other uses where the failure of the device or system could cause personal injury, death, or property damage ("Unintended Uses"). A critical component is any component of a device or system whose failure to perform can be reasonably expected to cause the failure of the device or system, or to affect its safety or effectiveness. Cypress is not liable, in whole or in part, and you shall and hereby do release Cypress from any claim, damage, or other liability arising from or related to all Unintended Uses of Cypress products. You shall indemnify and hold Cypress harmless from and against all claims, costs, damages, and other liabilities, including claims for personal injury or death, arising from or related to any Unintended Uses of Cypress products.

Cypress, the Cypress logo, Spansion, the Spansion logo, and combinations thereof, WICED, PSoC, CapSense, EZ-USB, F-RAM, and Traveo are trademarks or registered trademarks of Cypress in the United States and other countries. For a more complete list of Cypress trademarks, visit cypress.com. Other names and brands may be claimed as property of their respective owners.

X-ON Electronics

Largest Supplier of Electrical and Electronic Components

Click to view similar products for [SRAM](#) category:

Click to view products by [Cypress](#) manufacturer:

Other Similar products are found below :

[CY6116A-35DMB](#) [CY7C1049GN-10VXI](#) [CY7C128A-45DMB](#) [GS8161Z36DD-200I](#) [GS88237CB-200I](#) [RMLV0408EGSB-4S2#AA0](#)
[IDT70V5388S166BG](#) [IS64WV3216BLL-15CTLA3](#) [IS66WVE4M16ECLL-70BLI](#) [PCF8570P](#) [K6F2008V2E-LF70000](#) [K6T4008C1B-GB70](#)
[CY7C1353S-100AXC](#) [AS6C8016-55BIN](#) [AS7C164A-15PCN](#) [515712X](#) [IDT71V67603S133BG](#) [IS62WV51216EBLL-45BLI](#)
[IS63WV1288DBLL-10HLI](#) [IS66WVE2M16ECLL-70BLI](#) [70V639S10BCG](#) [IS66WVE4M16EALL-70BLI](#) [IS62WV6416DBLL-45BLI](#)
[IS61WV102416DBLL-10TLI](#) [CY7C1381KV33-100AXC](#) [CY7C1381KVE33-133AXI](#) [8602501XA](#) [5962-3829425MUA](#) [5962-3829430MUA](#)
[5962-8855206YA](#) [5962-8866201YA](#) [5962-8866204TA](#) [5962-8866206MA](#) [5962-8866208UA](#) [5962-8872502XA](#) [5962-9062007MXA](#) [5962-](#)
[9161705MXA](#) [70V3579S6BFI](#) [GS882Z18CD-150I](#) [M38510/28902BVA](#) [8413202RA](#) [5962-9161708MYA](#) [5962-8971203XA](#) [5962-](#)
[8971202ZA](#) [5962-8872501LA](#) [5962-8866208YA](#) [5962-8866205YA](#) [5962-8866205UA](#) [5962-8866203YA](#) [5962-8855202YA](#)