

## Features

- All outputs skew < 100 ps typical (250 max)
- 15 MHz to 80 MHz output operation
- Zero input to output delay
- 50% duty cycle outputs
- Outputs drive 50 Ω terminated lines
- Low operating current
- 24-pin small-outline integrated circuit (SOIC) package
- Jitter: < 200 ps peak-to-peak, < 25 ps RMS

## Functional Description

The CY7B9910 low skew clock buffer offers low skew system clock distribution. These multiple output clock drivers optimize the timing of high performance computer systems. Each of the eight individual drivers can drive terminated transmission lines with impedances as low as 50 Ω. They deliver minimal and specified output skews and full swing logic levels (CY7B9910 TTL).

The completely integrated PLL enables 'zero delay' capability. External divide capability, combined with the internal PLL, allows distribution of a low frequency clock that is multiplied by virtually any factor at the clock destination. This facility minimizes clock distribution difficulty while allowing maximum system clock speed and flexibility.

For a complete list of related documentation, [click here](#).

## Block Diagram Description

### Phase Frequency Detector and Filter

The phase frequency detector and Filter blocks accept inputs from the reference frequency (REF) input and the feedback (FB) input and generate correction information to control the frequency of the voltage controlled oscillator (VCO). These blocks, along with the VCO, form a phase-locked loop (PLL) that tracks the incoming REF signal.

### VCO

The VCO accepts analog control inputs from the PLL filter block and generates a frequency. The operational range of the VCO is determined by the FS control pin.

## Logic Block Diagram

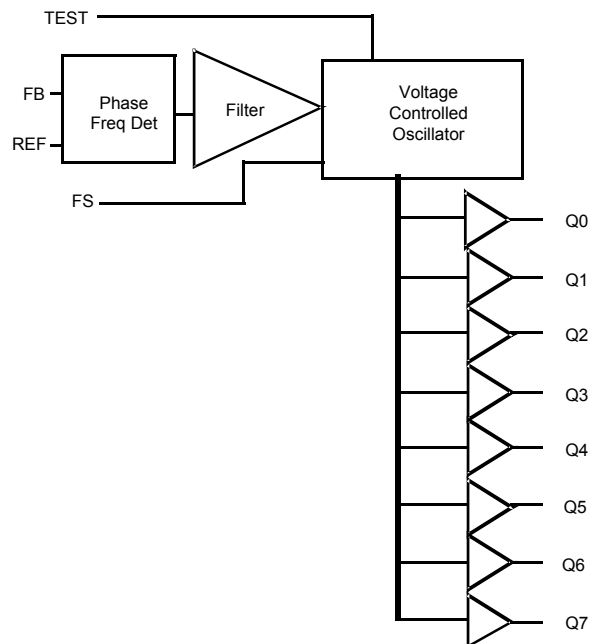

## Contents

<b>Pinouts</b> .....	<b>3</b>	<b>Package Diagram</b> .....	<b>11</b>
<b>Pin Definitions</b> .....	<b>3</b>	<b>Acronyms</b> .....	<b>12</b>
<b>Test Mode</b> .....	<b>3</b>	<b>Document Conventions</b> .....	<b>12</b>
<b>Maximum Ratings</b> .....	<b>4</b>	Units of Measure .....	12
<b>Operating Range</b> .....	<b>4</b>	<b>Document History Page</b> .....	<b>13</b>
<b>Electrical Characteristics</b> .....	<b>4</b>	<b>Sales, Solutions, and Legal Information</b> .....	<b>14</b>
<b>Capacitance</b> .....	<b>6</b>	Worldwide Sales and Design Support .....	14
<b>Thermal Resistance</b> .....	<b>6</b>	Products .....	14
<b>AC Test Loads and Waveforms</b> .....	<b>6</b>	PSoC@Solutions .....	14
<b>Switching Characteristics</b> .....	<b>7</b>	Cypress Developer Community .....	14
<b>AC Timing Diagrams</b> .....	<b>8</b>	Technical Support .....	14
<b>Operational Mode Descriptions</b> .....	<b>9</b>		
<b>Ordering Information</b> .....	<b>10</b>		
Ordering Code Definitions .....	10		

## Pinouts

Figure 1. 24-pin SOIC pinout

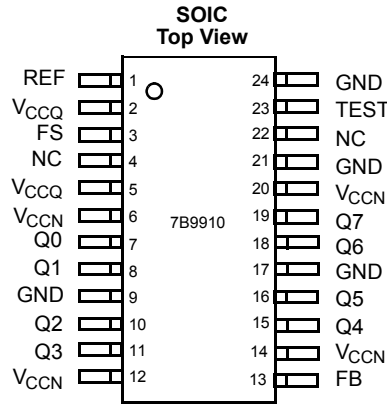

## Pin Definitions

Signal Name	I/O	Description
REF <sup>[1]</sup>	I	Reference frequency input. This input supplies the frequency and timing against which all functional variations are measured.
FB	I	PLL feedback input (typically connected to one of the eight outputs).
FS <sup>[1, 2, 3]</sup>	I	Three level frequency range select. The ranges are described in the switching characteristics tables.
TEST	I	Three level select. See <a href="#">Test Mode</a> .
Q[0..7]	O	Clock outputs.
NC	NC	No connect.
V <sub>CCN</sub>	PWR	Power supply for output drivers.
V <sub>CCQ</sub>	PWR	Power supply for internal circuitry.
GND	PWR	Ground.

## Test Mode

The TEST input is a three level input. In normal system operation, this pin is connected to ground, allowing the CY7B9910 to operate as described in [Block Diagram Description on page 1](#). For testing purposes, any of the three level inputs can have a removable jumper to ground or be tied LOW through a 100 Ω resistor. This enables an external tester to change the state of these pins.

If the TEST input is forced to its MID or HIGH state, the device operates with its internal phase locked loop disconnected and input levels supplied to REF directly control all outputs. Relative output-to-output functions are the same as in normal mode.

### Notes

- When the FS pin is selected HIGH, the REF input must not transition upon power up until V<sub>CC</sub> reached 4.3 V.
- The level to be set on FS is determined by the "normal" operating frequency (f<sub>NOM</sub>) of the VCO (see [Logic Block Diagram](#)). The frequency appearing at the REF and FB inputs are f<sub>NOM</sub> when the output connected to FB is undivided. The frequency of the REF and FB inputs are f<sub>NOM</sub> / X when the device is configured for a frequency multiplication by using external division in the feedback path of value X.
- For all three state inputs, HIGH indicates a connection to V<sub>CC</sub>, LOW indicates a connection to GND, and MID indicates an open connection. Internal termination circuitry holds an unconnected input to V<sub>CC</sub> / 2.

## Maximum Ratings

Exceeding maximum ratings may shorten the useful life of the device. User guidelines are not tested.

Storage temperature ..... -65 °C to +150 °C

Ambient temperature  
with power applied ..... -55 °C to +125 °C

Supply voltage to ground potential ..... -0.5 V to +7.0 V

DC input voltage ..... -0.5 V to +7.0 V

Output current into outputs (LOW) ..... 64 mA

Static discharge voltage  
(MIL-STD-883, method 3015) ..... > 2001 V

Latch-up current ..... > 200 mA

## Operating Range

Range	Ambient Temperature	V <sub>CC</sub>
Commercial	0 °C to +70 °C	5 V ± 10%
Industrial	-40 °C to +85 °C	5 V ± 10%

## Electrical Characteristics

Over the Operating Range

Parameter	Description	Test Conditions	CY7B9910		Unit
			Min	Max	
V <sub>OH</sub>	Output HIGH voltage	V <sub>CC</sub> = Min, I <sub>OH</sub> = -16 mA	2.4	-	V
		V <sub>CC</sub> = Min, I <sub>OH</sub> = -40 mA	-	-	
V <sub>OL</sub>	Output LOW voltage	V <sub>CC</sub> = Min, I <sub>OL</sub> = 46 mA	-	0.45	V
		V <sub>CC</sub> = Min, I <sub>OL</sub> = 46 mA	-	-	
V <sub>IH</sub>	Input HIGH voltage (REF and FB inputs only)		2.0	V <sub>CC</sub>	V
V <sub>IL</sub>	Input LOW voltage (REF and FB inputs only)		-0.5	0.8	V
V <sub>IHH</sub>	Three level input HIGH voltage (Test, FS) <sup>[4]</sup>	Min ≤ V <sub>CC</sub> ≤ Max	V <sub>CC</sub> - 1	V <sub>CC</sub>	V
V <sub>IMM</sub>	Three level input MID voltage (Test, FS) <sup>[4]</sup>	Min ≤ V <sub>CC</sub> ≤ Max	(V <sub>CC</sub> /2) - 0.5	(V <sub>CC</sub> /2) + 0.5	V
V <sub>ILL</sub>	Three level input LOW voltage (Test, FS) <sup>[4]</sup>	Min ≤ V <sub>CC</sub> ≤ Max	0.0	1.0	V

### Note

4. These inputs are normally wired to V<sub>CC</sub>, GND, or left unconnected (actual threshold voltages vary as a percentage of V<sub>CC</sub>). Internal termination resistors hold unconnected inputs at V<sub>CC</sub>/2. If these inputs are switched, the function and timing of the outputs may glitch and the PLL may require an additional t<sub>LOCK</sub> time before all datasheet limits are achieved.

**Electrical Characteristics** (continued)

Over the Operating Range

Parameter	Description	Test Conditions	CY7B9910		Unit	
			Min	Max		
$I_{IH}$	Input HIGH leakage current (REF and FB inputs only)	$V_{CC} = \text{Max}, V_{IN} = \text{Max}$	–	10	$\mu\text{A}$	
$I_{IL}$	Input LOW leakage current (REF and FB inputs only)	$V_{CC} = \text{Max}, V_{IN} = 0.4 \text{ V}$	–500	–	$\mu\text{A}$	
$I_{IHH}$	Input HIGH current (Test, FS)	$V_{IN} = V_{CC}$	–	200	$\mu\text{A}$	
$I_{IMM}$	Input MID current (Test, FS)	$V_{IN} = V_{CC} / 2$	–50	50	$\mu\text{A}$	
$I_{ILL}$	Input LOW current (Test, FS)	$V_{IN} = \text{GND}$	–	–200	$\mu\text{A}$	
$I_{OS}$	Output short circuit current <sup>[6]</sup>	$V_{CC} = \text{Max}, V_{OUT} = \text{GND}$ (25 °C only)	–	–250	mA	
$I_{CCQ}$	Operating current used by internal circuitry	$V_{CCN} = V_{CCQ} = \text{Max}$ All input selects open	Commercial	–	85	mA
			Industrial	–	90	
$I_{CCN}$	Output buffer current per output pair <sup>[6]</sup>	$V_{CCN} = V_{CCQ} = \text{Max}$ $I_{OUT} = 0 \text{ mA}$ Input selects open, $f_{MAX}$	–	14	mA	
PD	Power dissipation per output pair <sup>[7]</sup>	$V_{CCN} = V_{CCQ} = \text{Max}$ $I_{OUT} = 0 \text{ mA}$ Input selects open, $f_{MAX}$	–	78	mW	

**Notes**

- Tested one output at a time, output shorted for less than one second, less than 10% duty cycle. Room temperature only.
- Total output current per output pair is approximated by the following expression that includes device current plus load current:  
CY7B9910:  
 $ICC_N = [(4 + 0.11 F) + [(835 - 3 F) / Z] + (.0022 FC)] N] \times 1.1$

Where

 $F$  = frequency in MHz

 $C$  = capacitive load in pF

 $Z$  = line impedance in ohms

 $N$  = number of loaded outputs; 0, 1, or 2

 $FC = F \times C$ .

- Total power dissipation per output pair is approximated by the following expression that includes device power dissipation plus power dissipation due to the load circuit:  
CY7B9910:  
 $PD = [(22 + 0.61 F) + [(1550 - 2.7 F) / Z] + (.0125 FC)] N] \times 1.1$   
See note 3 for variable definition.
- CMOS output buffer current and power dissipation specified at 50 MHz reference frequency.

### Capacitance

Parameter <sup>[9, 10]</sup>	Description	Test Conditions	Max	Unit
C <sub>IN</sub>	Input capacitance	T <sub>A</sub> = 25 °C, f = 1 MHz, V <sub>CC</sub> = 5.0 V	10	pF

### Thermal Resistance

Parameter <sup>[10]</sup>	Description	Test Conditions	24-pin SOIC Package	Unit
Θ <sub>JA</sub>	Thermal resistance (junction to ambient)	Test conditions follow standard test methods and procedures for measuring thermal impedance, according to EIA/JESD51.	64	°C/W
Θ <sub>JC</sub>	Thermal resistance (junction to case)		28	°C/W

### AC Test Loads and Waveforms

Figure 2. AC Test Loads and Waveforms

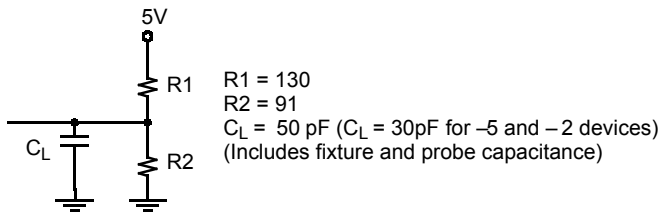

TTL AC Test Load (CY7B9910)

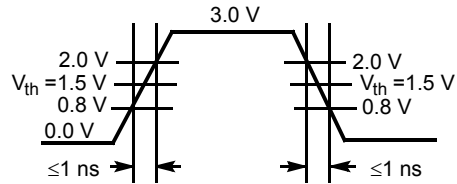

TTL Input Test Waveform (CY7B9910)

**Notes**

- 9. Applies to REF and FB inputs only.
- 10. Tested initially and after any design or process changes that may affect these parameters.

## Switching Characteristics

Over the Operating Range

Parameter <sup>[11]</sup>	Description	CY7B9910-5			Unit	
		Min	Typ	Max		
f <sub>NOM</sub>	Operating clock frequency in MHz	FS = LOW <sup>[12, 13]</sup>	15	–	30	MHz
		FS = MID <sup>[12, 13]</sup>	25	–	50	
		FS = HIGH <sup>[12, 13, 14]</sup>	40	–	80	
t <sub>RPWH</sub>	REF pulse width HIGH	5.0	–	–	ns	
t <sub>RPWL</sub>	REF pulse width LOW	5.0	–	–	ns	
t <sub>SKEW</sub>	Zero output skew (All outputs) <sup>[16, 17]</sup>	–	0.25	0.5	ns	
t <sub>DEV</sub>	Device-to-device skew <sup>[18, 19]</sup>	–	–	1.0	ns	
t <sub>PD</sub>	Propagation delay, REF rise to FB rise	–0.5	0.0	+0.5	ns	
t <sub>ODCV</sub>	Output duty cycle variation <sup>[20]</sup>	–1.0	0.0	+1.0	ns	
t <sub>ORISE</sub>	Output rise time <sup>[21, 22]</sup>	0.15	1.0	1.5	ns	
t <sub>OFALL</sub>	Output fall time <sup>[21, 22]</sup>	0.15	1.0	1.5	ns	
t <sub>LOCK</sub>	PLL lock time <sup>[23]</sup>	–	–	0.5	ms	
t <sub>JR</sub>	Cycle-to-cycle output jitter	Peak-to-peak <sup>[18]</sup>	–	–	200	ps
		RMS <sup>[18]</sup>	–	–	25	ps

### Notes

11. Test measurement levels for the CY7B9910 is TTL level (1.5 V to 1.5 V). Test conditions assume signal transition times of 2 ns or less and output loading as shown in the AC Test Loads and Waveforms unless otherwise specified.
12. For all three state inputs, HIGH indicates a connection to V<sub>CC</sub>, LOW indicates a connection to GND, and MID indicates an open connection. Internal termination circuitry holds an unconnected input to V<sub>CC</sub> / 2.
13. The level to be set on FS is determined by the "normal" operating frequency (f<sub>NOM</sub>) of the VCO (see [Logic Block Diagram](#)). The frequency appearing at the REF and FB inputs are f<sub>NOM</sub> when the output connected to FB is undivided. The frequency of the REF and FB inputs are f<sub>NOM</sub> / X when the device is configured for a frequency multiplication by using external division in the feedback path of value X.
14. When the FS pin is selected HIGH, the REF input must not transition upon power up until V<sub>CC</sub> reached 4.3 V.
- 15.
16. t<sub>SKEW</sub> is defined as the time between the earliest and the latest output transition among all outputs when all are loaded with 50 pF and terminated with 50 Ω to 2.06 V (CY7B9910)
17. t<sub>SKEW</sub> is defined as the skew between outputs.
18. Guaranteed by statistical correlation. Tested initially and after any design or process changes that may affect these parameters.
19. t<sub>DEV</sub> is the output-to-output skew between any two outputs on separate devices operating under the same conditions (V<sub>CC</sub>, ambient temperature, air flow, and so on).
20. t<sub>ODCV</sub> is the deviation of the output from a 50% duty cycle.
21. Specified with outputs loaded with 30 pF for the CY7B9910–2 and –5 devices and 50 pF for the CY7B9910–7 devices. Devices are terminated through 50 Ω to 2.06 V (CY7B9910)
22. t<sub>ORISE</sub> and t<sub>OFALL</sub> measured between 0.8 V and 2.0 V for the CY7B9910
23. t<sub>LOCK</sub> is the time that is required before synchronization is achieved. This specification is valid only after V<sub>CC</sub> is stable and within normal operating limits. This parameter is measured from the application of a new signal or frequency at REF or FB until t<sub>PD</sub> is within specified limits.

**AC Timing Diagrams**

**Figure 3. AC Timing Diagrams**

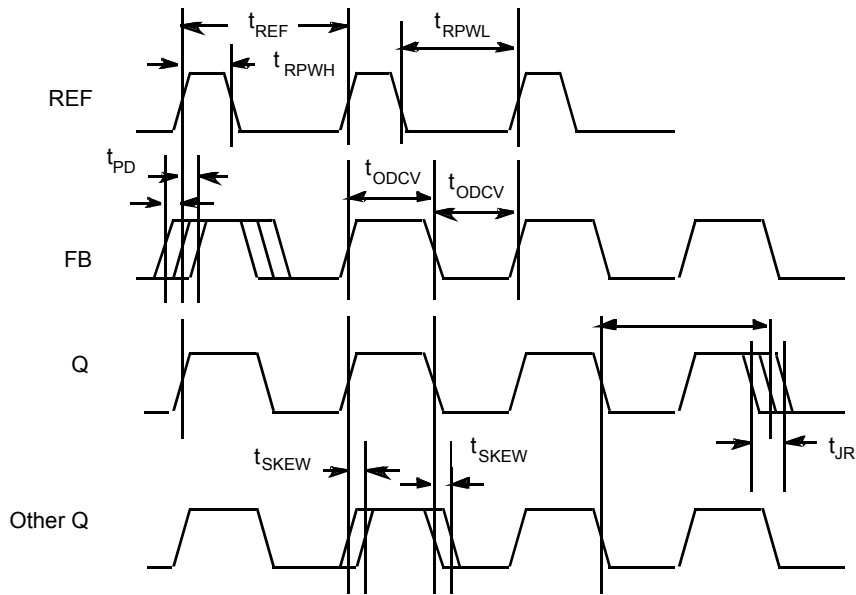

**Figure 4. Zero Skew and Zero Delay Clock Driver**

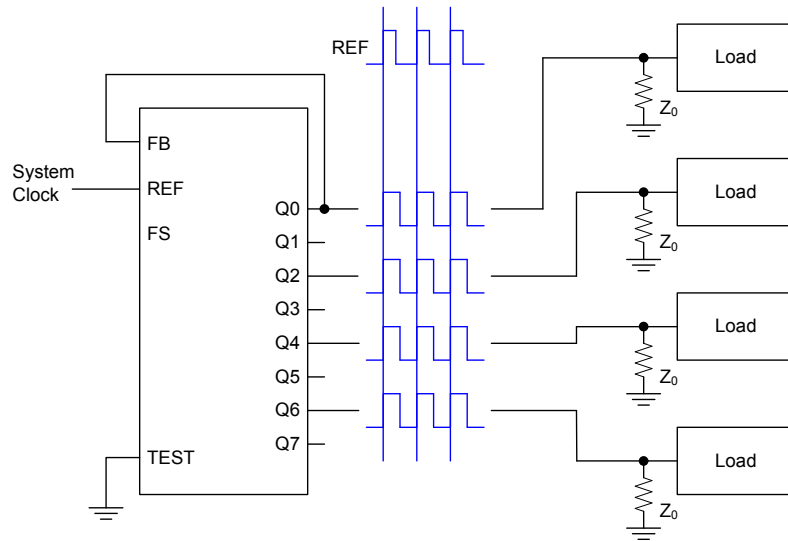



## Operational Mode Descriptions

Figure 4 on page 8 shows the device configured as a zero skew clock buffer. In this mode the CY7B9910 is used as the basis for a low skew clock distribution tree. The outputs are aligned and may each drive a terminated transmission line to an independent load. The FB input is tied to any output and the operating frequency range is selected with the FS pin. The low skew specification, coupled with the ability to drive terminated transmission

lines (with impedances as low as 50 ohms), enables efficient printed circuit board design.

Figure 3 on page 8 shows the CY7B9910 connected in series to construct a zero skew clock distribution tree between boards. Cascaded clock buffers accumulate low frequency jitter because of the non-ideal filtering characteristics of the PLL filter. Do not connect more than two clock buffers in series.

**Figure 5. Board-to-Board Clock Distribution**

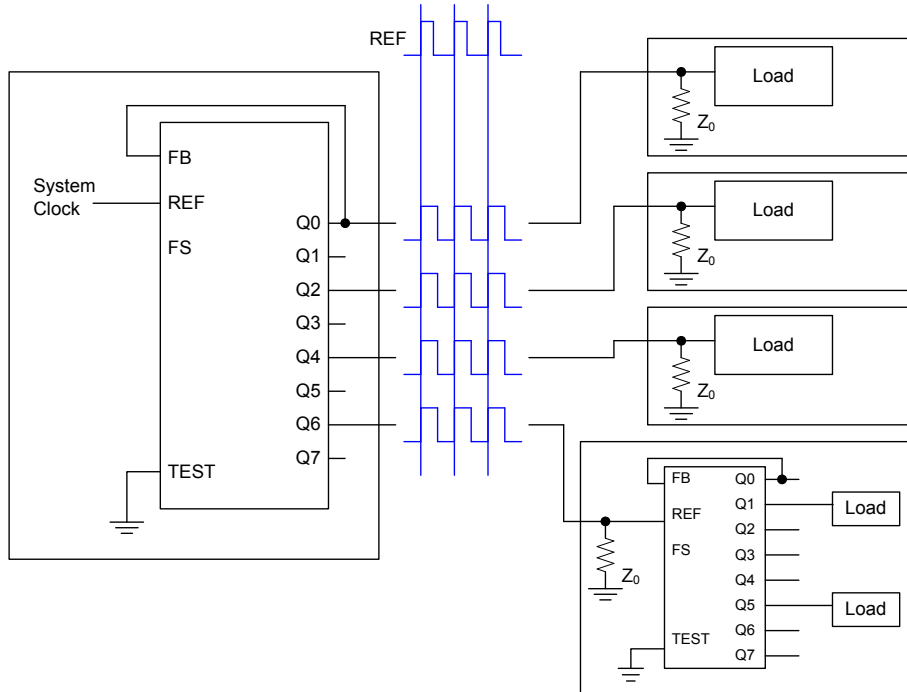

**Ordering Information**

Accuracy (ps)	Ordering Code	Package Type	Operating Range
<b>Pb-free</b>			
500	CY7B9910-5SXI	24-pin Small Outline IC	Industrial, -40 °C to +85 °C
	CY7B9910-5SXIT	24-pin Small Outline IC – Tape and Reel	Industrial, -40 °C to +85 °C

**Ordering Code Definitions**

CY 7B99X0 - 5 S X I X

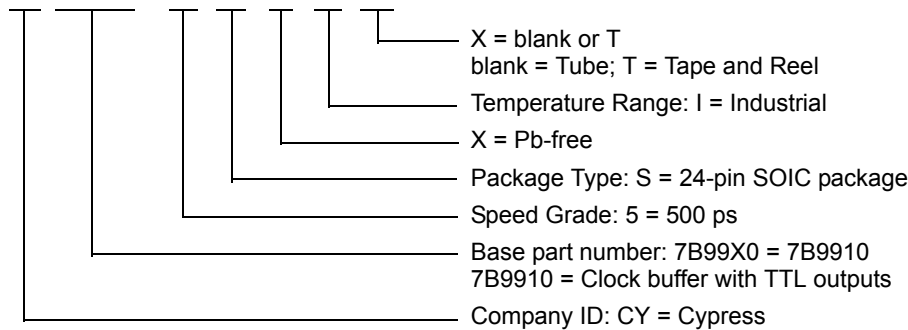

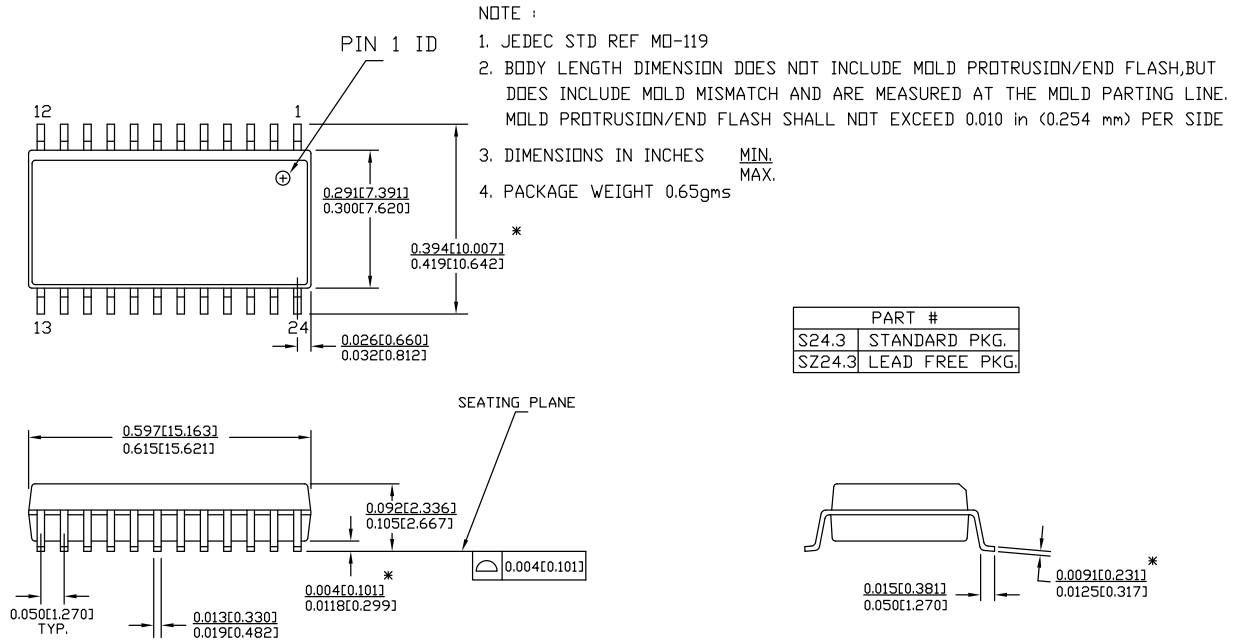
**Package Diagram**
**Figure 6. 24-pin SOIC (0.615 × 0.300 × 0.0932 Inches) Package Outline, 51-85025**

51-85025 \*F

## Acronyms

Acronym	Description
FB	Feedback
PLL	Phase-Locked Loop
SOIC	Small-Outline Integrated Circuit
VCO	Voltage Controlled Oscillator

## Document Conventions

### Units of Measure

Symbol	Unit of Measure
°C	degree Celsius
kΩ	kilohm
MHz	megahertz
μA	microampere
mA	milliampere
ms	millisecond
mW	milliwatt
ns	nanosecond
Ω	ohm
ppm	parts per million
%	percent
pF	picofarad
ps	picosecond
V	volt

**Document History Page**

Document Title: CY7B9910, Low Skew Clock Buffer Document Number: 38-07135				
Revision	ECN	Orig. of Change	Submission Date	Description of Change
**	110244	SZV	10/28/01	Change from Specification number: 38-00437 to 38-07135.
*A	1199925	DPF / AESA	See ECN	Updated <a href="#">Ordering Information</a> : Added Pb-free parts in Ordering Information. Added Note "Not recommended for the new design" and referred the same note in CY7B9920-2SC, CY7B9910-7SI, CY7B9920-7SC, CY7B9920-7SI.
*B	1353343	AESA	See ECN	Change status from Preliminary to Final.
*C	2750166	TSAI	08/10/09	Post to external web.
*D	2761988	CXQ	09/10/09	Updated <a href="#">Test Mode</a> : Fixed typo (Replaced 100 W resistor with 100 Ω resistor). Updated <a href="#">Ordering Information</a> : Referred Note "Not recommended for new designs" in CY7B9910-2SC, CY7B9910-2SCT, CY7B9910-5SC, CY7B9910-5SCT, CY7B9920-5SC, CY7B9920-5SCT, CY7B9920-5SI, CY7B9910-7SC. Fixed incorrect instances (Replaced "Pb" with "Pin").
*E	2896073	CXQ	03/19/10	Updated <a href="#">Ordering Information</a> : Removed inactive parts. Updated <a href="#">Package Diagram</a> .
*F	3010397	KVM	08/18/2010	Added <a href="#">Ordering Code Definitions</a> .
*G	3047620	BASH	10/07/2010	Updated <a href="#">Ordering Information</a> : Removed pruned parts. Removed associated tables.
*H	4163293	CINM	10/17/2013	Updated <a href="#">Package Diagram</a> : spec 51-85025 – Changed revision from *D to *E. Updated to new template. Completing Sunset Review.
*I	4416541	AJU	06/23/2014	Updated <a href="#">Ordering Information</a> : No change in part numbers. Removed the Note "Not recommended for new design. New designs should use Pb-free devices." and its reference in "CY7B9920-5SI". Added "Not Recommended for New Designs" against the MPN "CY7B9920-5SI". Updated <a href="#">Package Diagram</a> : spec 51-85025 – Changed revision from *E to *F.
*J	4570101	AJU	11/14/2014	Updated <a href="#">Functional Description</a> : Added "For a complete list of related documentation, <a href="#">click here</a> ." at the end.
*K	5270360	PSR	05/13/2016	Updated <a href="#">Electrical Characteristics</a> : Updated Note 6 (Replaced "FC = F < C" with "FC = F × C"). Added <a href="#">Thermal Resistance</a> . Updated to new template.
*L	5493470	XHT	11/04/2016	Updated Document Title to read as "CY7B9910, Low Skew Clock Buffer". Removed CY7B9920 part related information in all instances across the document. Updated <a href="#">Ordering Information</a> : Updated part numbers. Updated to new template. Completing Sunset Review.
*M	5975902	AESATMP9	11/24/2017	Updated logo and copyright.

## Sales, Solutions, and Legal Information

### Worldwide Sales and Design Support

Cypress maintains a worldwide network of offices, solution centers, manufacturer's representatives, and distributors. To find the office closest to you, visit us at [Cypress Locations](#).

#### Products

ARM® Cortex® Microcontrollers	<a href="http://cypress.com/arm">cypress.com/arm</a>
Automotive	<a href="http://cypress.com/automotive">cypress.com/automotive</a>
Clocks & Buffers	<a href="http://cypress.com/clocks">cypress.com/clocks</a>
Interface	<a href="http://cypress.com/interface">cypress.com/interface</a>
Internet of Things	<a href="http://cypress.com/iot">cypress.com/iot</a>
Memory	<a href="http://cypress.com/memory">cypress.com/memory</a>
Microcontrollers	<a href="http://cypress.com/mcu">cypress.com/mcu</a>
PSoC	<a href="http://cypress.com/psoc">cypress.com/psoc</a>
Power Management ICs	<a href="http://cypress.com/pmic">cypress.com/pmic</a>
Touch Sensing	<a href="http://cypress.com/touch">cypress.com/touch</a>
USB Controllers	<a href="http://cypress.com/usb">cypress.com/usb</a>
Wireless Connectivity	<a href="http://cypress.com/wireless">cypress.com/wireless</a>

#### PSoC® Solutions

[PSoC 1](#) | [PSoC 3](#) | [PSoC 4](#) | [PSoC 5LP](#) | [PSoC 6](#)

#### Cypress Developer Community

[Forums](#) | [WICED IOT Forums](#) | [Projects](#) | [Video](#) | [Blogs](#) | [Training](#) | [Components](#)

#### Technical Support

[cypress.com/support](http://cypress.com/support)

---

© Cypress Semiconductor Corporation, 2001-2017. This document is the property of Cypress Semiconductor Corporation and its subsidiaries, including Spansion LLC ("Cypress"). This document, including any software or firmware included or referenced in this document ("Software"), is owned by Cypress under the intellectual property laws and treaties of the United States and other countries worldwide. Cypress reserves all rights under such laws and treaties and does not, except as specifically stated in this paragraph, grant any license under its patents, copyrights, trademarks, or other intellectual property rights. If the Software is not accompanied by a license agreement and you do not otherwise have a written agreement with Cypress governing the use of the Software, then Cypress hereby grants you a personal, non-exclusive, nontransferable license (without the right to sublicense) (1) under its copyright rights in the Software (a) for Software provided in source code form, to modify and reproduce the Software solely for use with Cypress hardware products, only internally within your organization, and (b) to distribute the Software in binary code form externally to end users (either directly or indirectly through resellers and distributors), solely for use on Cypress hardware product units, and (2) under those claims of Cypress's patents that are infringed by the Software (as provided by Cypress, unmodified) to make, use, distribute, and import the Software solely for use with Cypress hardware products. Any other use, reproduction, modification, translation, or compilation of the Software is prohibited.

TO THE EXTENT PERMITTED BY APPLICABLE LAW, CYPRESS MAKES NO WARRANTY OF ANY KIND, EXPRESS OR IMPLIED, WITH REGARD TO THIS DOCUMENT OR ANY SOFTWARE OR ACCOMPANYING HARDWARE, INCLUDING, BUT NOT LIMITED TO, THE IMPLIED WARRANTIES OF MERCHANTABILITY AND FITNESS FOR A PARTICULAR PURPOSE. To the extent permitted by applicable law, Cypress reserves the right to make changes to this document without further notice. Cypress does not assume any liability arising out of the application or use of any product or circuit described in this document. Any information provided in this document, including any sample design information or programming code, is provided only for reference purposes. It is the responsibility of the user of this document to properly design, program, and test the functionality and safety of any application made of this information and any resulting product. Cypress products are not designed, intended, or authorized for use as critical components in systems designed or intended for the operation of weapons, weapons systems, nuclear installations, life-support devices or systems, other medical devices or systems (including resuscitation equipment and surgical implants), pollution control or hazardous substances management, or other uses where the failure of the device or system could cause personal injury, death, or property damage ("Unintended Uses"). A critical component is any component of a device or system whose failure to perform can be reasonably expected to cause the failure of the device or system, or to affect its safety or effectiveness. Cypress is not liable, in whole or in part, and you shall and hereby do release Cypress from any claim, damage, or other liability arising from or related to all Unintended Uses of Cypress products. You shall indemnify and hold Cypress harmless from and against all claims, costs, damages, and other liabilities, including claims for personal injury or death, arising from or related to any Unintended Uses of Cypress products.

Cypress, the Cypress logo, Spansion, the Spansion logo, and combinations thereof, WICED, PSoC, CapSense, EZ-USB, F-RAM, and Traveo are trademarks or registered trademarks of Cypress in the United States and other countries. For a more complete list of Cypress trademarks, visit [cypress.com](http://cypress.com). Other names and brands may be claimed as property of their respective owners.

## X-ON Electronics

Largest Supplier of Electrical and Electronic Components

*Click to view similar products for [Phase Locked Loops - PLL category](#):*

*Click to view products by [Cypress manufacturer](#):*

Other Similar products are found below :

[ADF4152HVBCPZ-RL7](#) [HMC440QS16GTR](#) [LC72135MA-Q-AE](#) [SL28EB725ALI](#) [HMC699LP5ETR](#) [HMC700LP4TR](#) [LC7185-8750-E](#)  
[MB15E07SLPFV1-G-BND-6E1](#) [XRT8001ID-F](#) [ATA8404C-6DQY-66](#) [PI6C2409-1HWE](#) [ATA8405C-6DQY-66](#) [MAX2870ETJ+T](#)  
[PI6C2409-1HWEX](#) [CYW170-01SXC](#) [HMC764LP6CETR](#) [HMC767LP6CETR](#) [HMC820LP6CETR](#) [HMC828LP6CETR](#) [HMC834LP6GETR](#)  
[ispPAC-CLK5410D-01SN64C](#) [SI4113-D-GM](#) [82V3002APVG](#) [PI6C2405A-1WE](#) [CY22050KFI](#) [CY25200KFZXC](#) [CY29973AXI](#)  
[CY2XP22ZXI](#) [W232ZXC-10](#) [CDCE937QPWRQ1](#) [CY2077FZXI](#) [CY2546FC](#) [CY2XF23FLXIT](#) [CYISM560BSXC](#) [LMX2430TMX/NOPB](#)  
[HMC837LP6CETR](#) [HMC831LP6CETR](#) [ATA8404C-6DQY-66](#) [ADF4155BCPZ-RL7](#) [MB15E07SRPFT-G-BNDE1](#) [NB3N5573DTG](#)  
[MAX2660EUT+T](#) [SI4123-D-GT](#) [SI4112-D-GM](#) [NB4N441MNR2G](#) [ADF4116BRUZ-REEL7](#) [ADF4153ABCPZ](#) [MAX2682EUT+T](#) [Si5376B-](#)  
[A-GL](#) [SI5347A-A-GM](#)