

Features

- Pin- and function-compatible with CY7C1020CV33
- Temperature Ranges
 - Commercial: 0 °C to 70 °C
 - Industrial: -40 °C to 85 °C
 - Automotive: -40 °C to 125 °C
- High speed
 - $t_{AA} = 10 \text{ ns}$
- CMOS for optimum speed/power
- Low active power
 - 325 mW (max)
- Automatic power-down when deselected
- Independent control of upper and lower bits
- Available in Pb-free and non Pb-free 44-pin TSOP II package

Functional Description

The CY7C1020CV33 is a high-performance CMOS static RAM organized as 32,768 words by 16 bits. This device has an automatic power-down feature that significantly reduces power consumption when deselected.

Writing to the device is accomplished by taking Chip Enable (\overline{CE}) and Write Enable (WE) inputs LOW. If Byte Low Enable (BLE) is LOW, then data from I/O pins (I/O₁ through I/O₈), is written into the location specified on the address pins (A₀ through A₁₄). If Byte High Enable (BHE) is LOW, then data from I/O pins (I/O₉ through I/O₁₆) is written into the location specified on the address pins (A₀ through A₁₄).

Reading from the device is accomplished by taking Chip Enable (\overline{CE}) and Output Enable (\overline{OE}) LOW while forcing the Write Enable (WE) HIGH. If Byte Low Enable (BLE) is LOW, then data from the memory location specified by the address pins will appear on I/O₁ to I/O₈. If Byte High Enable (BHE) is LOW, then data from memory will appear on I/O₉ to I/O₁₆. See the truth table at the back of this data sheet for a complete description of read and write modes.

The input/output pins (I/O₁ through I/O₁₆) are placed in a high-impedance state when the device is deselected (\overline{CE} HIGH), the outputs are disabled (\overline{OE} HIGH), the BHE and BLE are disabled (BHE, BLE HIGH), or during a write operation (\overline{CE} LOW, and WE LOW).

The CY7C1020CV33 is available in standard 44-pin TSOP Type II package.

For a complete list of related resources, [click here](#).

Logic Block Diagram

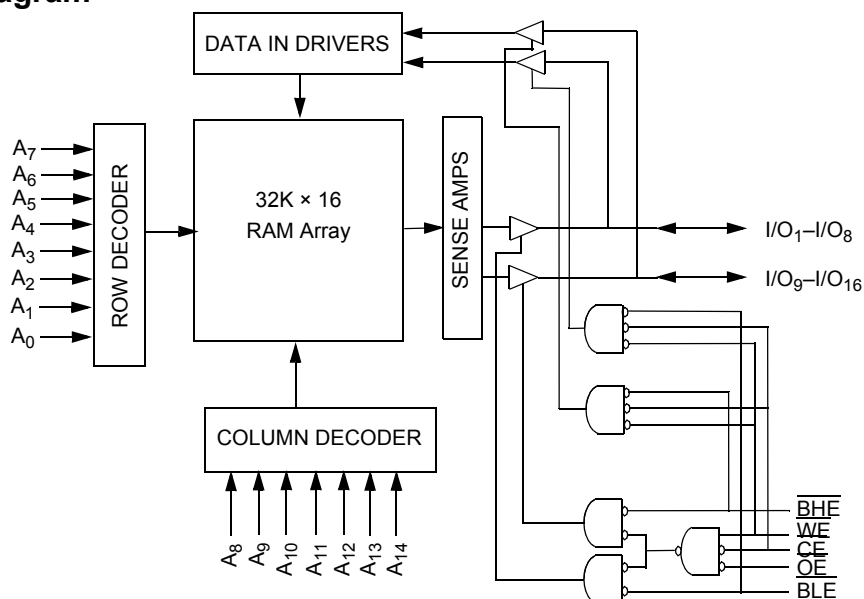

Contents

Selection Guide	3	Package Diagrams	13
Pin Configuration	3	Acronyms	14
Pin Definitions	4	Document Conventions	14
Maximum Ratings	5	Units of Measure	14
Operating Range	5	Document History Page	15
Electrical Characteristics	5	Sales, Solutions, and Legal Information	17
Capacitance	6	Worldwide Sales and Design Support	17
Thermal Resistance	6	Products	17
AC Test Loads and Waveforms	6	PSoC® Solutions	17
Switching Characteristics	7	Cypress Developer Community	17
Switching Waveforms	8	Technical Support	17
Truth Table	11		
Ordering Information	12		
Ordering Code Definitions	12		

Selection Guide

Description		-10	-12	-15	Unit
Maximum Access Time		10	12	15	ns
Maximum Operating Current	Commercial/Industrial	90	85	80	mA
	Automotive	–	–	85	mA
Maximum CMOS Standby Current	Commercial/Industrial	5	5	5	mA
	Automotive	–	–	10	mA

Pin Configuration

Figure 1. 44-pin TSOP Type II pinout (Top View) ^[1]

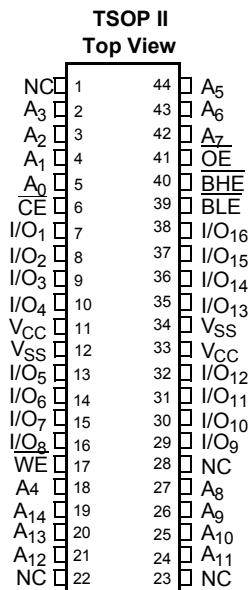

Note

1. NC pins are not connected on the die.

Pin Definitions

Pin Name	Pin Number	I/O Type	Description
A ₀ –A ₁₄	5, 4, 3, 2, 18, 44, 43, 42, 27, 26, 25, 24, 21, 20, 19	Input	Address Inputs used to select one of the address locations.
I/O ₁ –I/O ₁₆	7–10, 13–16, 29–32, 35–38	Input/Output	Bidirectional Data I/O lines. Used as input or output lines depending on operation.
NC	1, 22, 23, 28	No Connect	No Connects. Not connected to the die.
$\overline{\text{WE}}$	17	Input/Control	Write Enable Input, active LOW. When selected LOW, a Write is conducted. When deselected HIGH, a Read is conducted.
$\overline{\text{CE}}$	6	Input/Control	Chip Enable Input, active LOW. When LOW, selects the chip. When HIGH, deselects the chip.
$\overline{\text{BHE}}$, $\overline{\text{BLE}}$	40, 39	Input/Control	Byte Write Select Inputs, active LOW. $\overline{\text{BHE}}$ controls I/O ₁₆ –I/O ₉ , $\overline{\text{BLE}}$ controls I/O ₈ –I/O ₁ .
$\overline{\text{OE}}$	41	Input/Control	Output Enable, active LOW. Controls the direction of the I/O pins. When LOW, the I/O pins are allowed to behave as outputs. When deasserted HIGH, I/O pins are tri-stated, and act as input data pins.
V _{SS}	12, 34	Ground	Ground for the device. Should be connected to ground of the system.
V _{CC}	11, 33	Power Supply	Power Supply inputs to the device.

Maximum Ratings

Exceeding maximum ratings may shorten the useful life of the device. User guidelines are not tested.

Storage temperature -65 °C to +150 °C
 Ambient temperature with power applied -55 °C to +125 °C
 Supply voltage on V_{CC} to relative GND [2] -0.5 V to +4.6 V
 DC voltage applied to outputs in high Z State [2] -0.5 V to $V_{CC} + 0.5$ V
 DC input voltage [2] -0.5 V to $V_{CC} + 0.5$ V

Current into outputs (LOW) 20 mA
 Static discharge voltage (per MIL-STD-883, method 3015) > 2001 V
 Latch-up current > 200 mA

Operating Range

Range	Ambient Temperature	V_{CC}
Commercial	0 °C to +70 °C	3.3 V ± 10%
Industrial	-40 °C to +85 °C	3.3 V ± 10%
Automotive	-40 °C to +125 °C	3.3 V ± 10%

Electrical Characteristics

Over the Operating Range

Parameter	Description	Test Conditions	-10		-12		-15		Unit	
			Min	Max	Min	Max	Min	Max		
V_{OH}	Output HIGH voltage	$V_{CC} = \text{Min}, I_{OH} = -4.0 \text{ mA}$	2.4	-	2.4	-	2.4	-	V	
V_{OL}	Output LOW voltage	$V_{CC} = \text{Min}, I_{OL} = 8.0 \text{ mA}$	-	0.4	-	0.4	-	0.4	V	
V_{IH}	Input HIGH voltage		2.0	$V_{CC} + 0.3$	2.0	$V_{CC} + 0.3$	2.0	$V_{CC} + 0.3$	V	
V_{IL}	Input LOW voltage [2]		-0.3	0.8	-0.3	0.8	-0.3	0.8	V	
I_{IX}	Input leakage current	$GND \leq V_I \leq V_{CC}$	Commercial / Industrial	-1	+1	-1	+1	-1	+1	μA
			Automotive	-	-	-	-	-20	+20	μA
I_{OZ}	Output leakage current	$GND \leq V_I \leq V_{CC}$, Output Disabled	Commercial / Industrial	-1	+1	-1	+1	-1	+1	μA
			Automotive	-	-	-	-	-20	+20	μA
I_{CC}	V_{CC} operating supply current	$V_{CC} = \text{Max}, I_{OUT} = 0 \text{ mA}, f = f_{MAX} = 1/t_{RC}$	Commercial / Industrial	-	90	-	85	-	80	mA
			Automotive	-	-	-	-	-	85	mA
I_{SB1}	Automatic CE power-down current – TTL Inputs	Max V_{CC} , CE $\geq V_{IH}$, $V_{IN} \geq V_{IH}$ or $V_{IN} \leq V_{IL}$, $f = f_{MAX}$	Commercial / Industrial	-	15	-	15	-	15	mA
			Automotive	-	-	-	-	-	20	mA
I_{SB2}	Automatic CE power-down current – CMOS inputs	Max V_{CC} , CE $\geq V_{CC} - 0.3 \text{ V}$, $V_{IN} \geq V_{CC} - 0.3 \text{ V}$, or $V_{IN} \leq 0.3 \text{ V}$, $f = 0$	Commercial / Industrial	-	5	-	5	-	5	mA
			Automotive	-	-	-	-	-	10	mA

Note

2. $V_{IL}(\text{min}) = -2.0 \text{ V}$ and $V_{IH}(\text{max}) = V_{CC} + 0.5 \text{ V}$ for pulse durations of less than 20 ns.

Capacitance

Parameter ^[3]	Description	Test Conditions	Max	Unit
C _{IN}	Input capacitance	T _A = 25 °C, f = 1 MHz, V _{CC} = 3.3 V	8	pF
C _{OUT}	Output capacitance		8	pF

Thermal Resistance

Parameter ^[3]	Description	Test Conditions	44-pin TSOP-II	Unit
Θ _{JA}	Thermal resistance (junction to ambient)	Test conditions follow standard test methods and procedures for measuring thermal impedance, per EIA/JESD51.	76.92	°C/W
Θ _{JC}	Thermal resistance (junction to case)		15.86	°C/W

AC Test Loads and Waveforms

Figure 2. AC Test Loads and Waveforms ^[4]

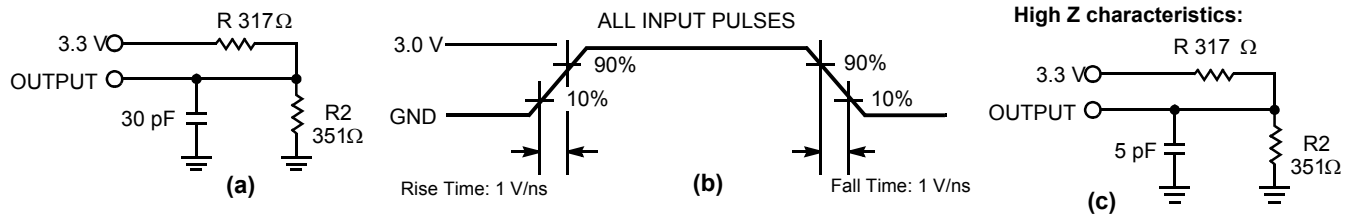

Notes

- 3. Tested initially and after any design or process changes that may affect these parameters.
- 4. Test conditions assume signal transition time of 3 ns or less, timing reference levels of 1.5 V, input pulse levels of 0 to 3.0 V.

Switching Characteristics

Over the Operating Range

Parameter ^[5]	Description	-10		-12		-15		Unit
		Min	Max	Min	Max	Min	Max	
Read Cycle								
t_{RC}	Read cycle time	10	–	12	–	15	–	ns
t_{AA}	Address to data valid	–	10	–	12	–	15	ns
t_{OHA}	Data hold from address change	3	–	3	–	3	–	ns
t_{ACE}	\overline{CE} LOW to data valid	–	10	–	12	–	15	ns
t_{DOE}	\overline{OE} LOW to data valid	–	5	–	6	–	7	ns
t_{LZOE}	\overline{OE} LOW to low Z ^[6]	0	–	0	–	0	–	ns
t_{HZOE}	\overline{OE} HIGH to high Z ^[6, 7]	–	5	–	6	–	7	ns
t_{LZCE}	\overline{CE} LOW to low Z ^[6]	3	–	3	–	3	–	ns
t_{HZCE}	\overline{CE} HIGH to high Z ^[6, 7]	–	5	–	6	–	7	ns
$t_{PU}^{[8]}$	\overline{CE} LOW to power-up	0	–	0	–	0	–	ns
$t_{PD}^{[8]}$	\overline{CE} HIGH to power-down	–	10	–	12	–	15	ns
t_{DBE}	Byte enable to data valid	–	5	–	6	–	7	ns
t_{LZBE}	Byte enable to low Z	0	–	0	–	0	–	ns
t_{HZBE}	Byte disable to high Z	–	5	–	6	–	7	ns
Write Cycle ^[9, 10]								
t_{WC}	Write cycle time	10	–	12	–	15	–	ns
t_{SCE}	\overline{CE} LOW to write end	8	–	9	–	10	–	ns
t_{AW}	Address set-up to write end	7	–	8	–	10	–	ns
t_{HA}	Address hold from write end	0	–	0	–	0	–	ns
t_{SA}	Address set-up to write start	0	–	0	–	0	–	ns
t_{PWE}	\overline{WE} pulse width	7	–	8	–	10	–	ns
t_{SD}	Data set-up to write end	5	–	6	–	8	–	ns
t_{HD}	Data hold from write end	0	–	0	–	0	–	ns
t_{LZWE}	\overline{WE} HIGH to low Z ^[6]	3	–	3	–	3	–	ns
t_{HZWE}	\overline{WE} LOW to high Z ^[6, 7]	–	5	–	6	–	7	ns
t_{BW}	Byte enable to end of write	7	–	8	–	9	–	ns

Notes

- Test conditions assume signal transition time of 3 ns or less, timing reference levels of 1.5 V, input pulse levels of 0 to 3.0 V.
- At any given temperature and voltage condition, t_{HZCE} is less than t_{LZCE} , t_{HZOE} is less than t_{LZOE} , and t_{HZWE} is less than t_{LZWE} for any given device.
- t_{HZOE} , t_{HZBE} , t_{HZCE} , and t_{HZWE} are specified with a load capacitance of 5 pF as in part (c) of AC Test Loads. Transition is measured ± 500 mV from steady-state voltage.
- This parameter is guaranteed by design and is not tested.
- The internal Write time of the memory is defined by the overlap of \overline{CE} LOW, \overline{WE} LOW and $\overline{BHE}/\overline{BLE}$ LOW. \overline{CE} , \overline{WE} and $\overline{BHE}/\overline{BLE}$ must be LOW to initiate a Write, and the transition of these signals can terminate the Write. The input data set-up and hold timing should be referenced to the leading edge of the signal that terminates the Write.
- The minimum write pulse width for Write Cycle No. 3 (\overline{WE} Controlled, \overline{OE} LOW) should be sum of t_{SD} and t_{HZWE} .

Switching Waveforms

Figure 3. Read Cycle No. 1 [11, 12]

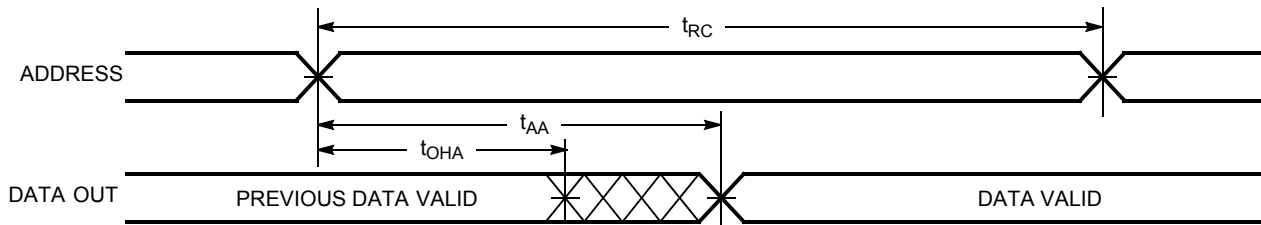
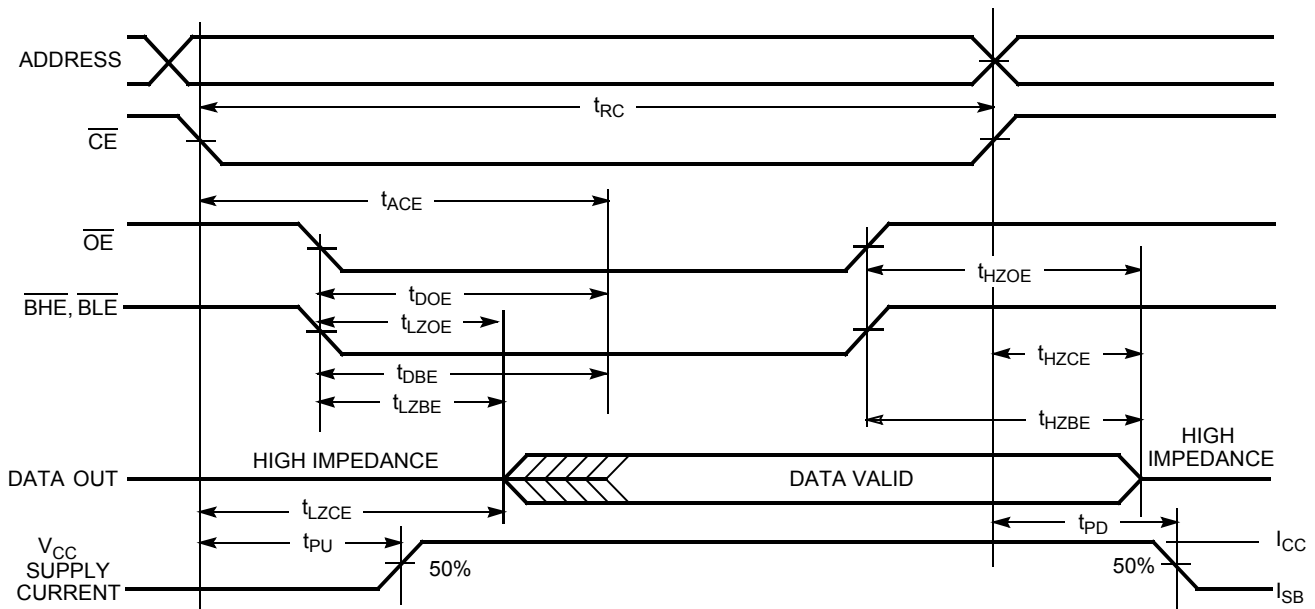

Figure 4. Read Cycle No. 2 (\overline{OE} Controlled) [12, 13]



Notes

- 11. Device is continuously selected. \overline{OE} , \overline{CE} , \overline{BHE} and/or \overline{BLE} = V_{IL} .
- 12. \overline{WE} is HIGH for Read cycle.
- 13. Address valid prior to or coincident with \overline{CE} transition LOW.

Switching Waveforms (continued)

Figure 5. Write Cycle No. 1 ($\overline{\text{CE}}$ Controlled) [14, 15]

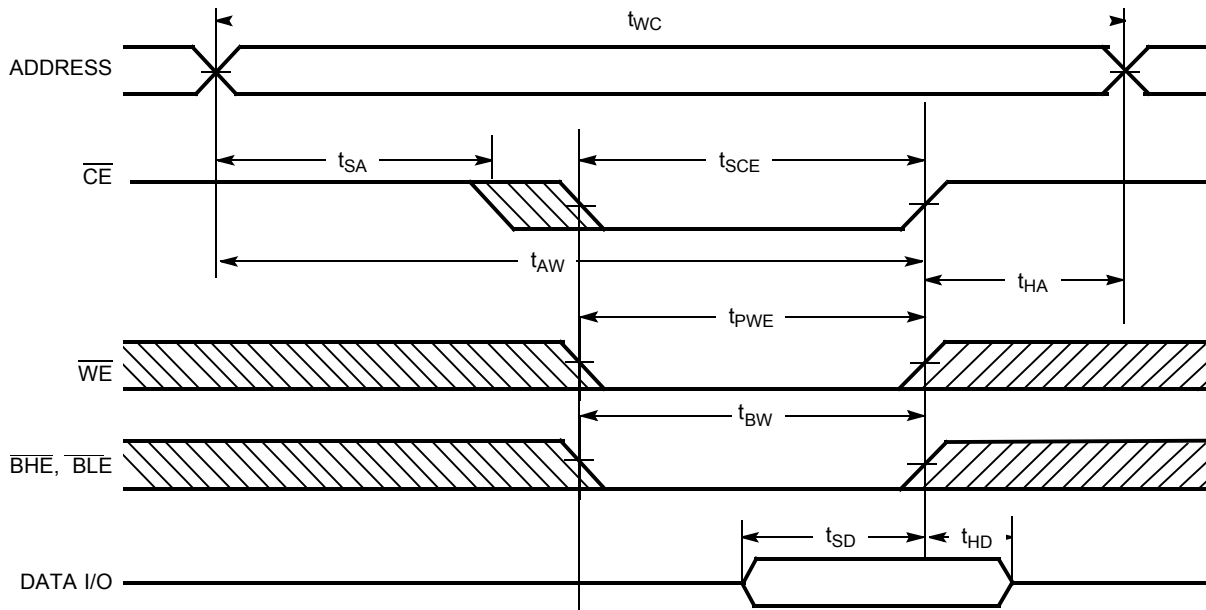
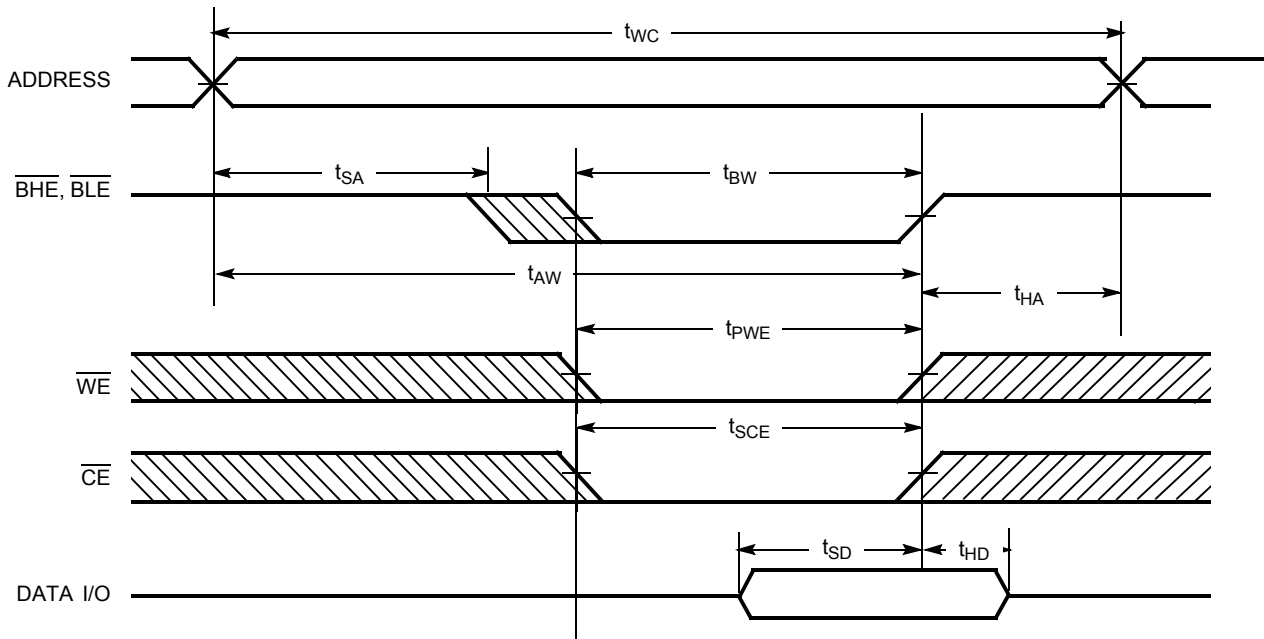

Figure 6. Write Cycle No. 2 ($\overline{\text{BLE}}$ or $\overline{\text{BHE}}$ Controlled)



Notes

- 14. Data I/O is high impedance if $\overline{\text{OE}}$ or $\overline{\text{BHE}}$ and/or $\overline{\text{BLE}} = V_{IH}$.
- 15. If $\overline{\text{CE}}$ goes HIGH simultaneously with $\overline{\text{WE}}$ going HIGH, the output remains in a high-impedance state.

Switching Waveforms (continued)

Figure 7. Write Cycle No. 3 (\overline{WE} Controlled, \overline{OE} LOW) ^[16]

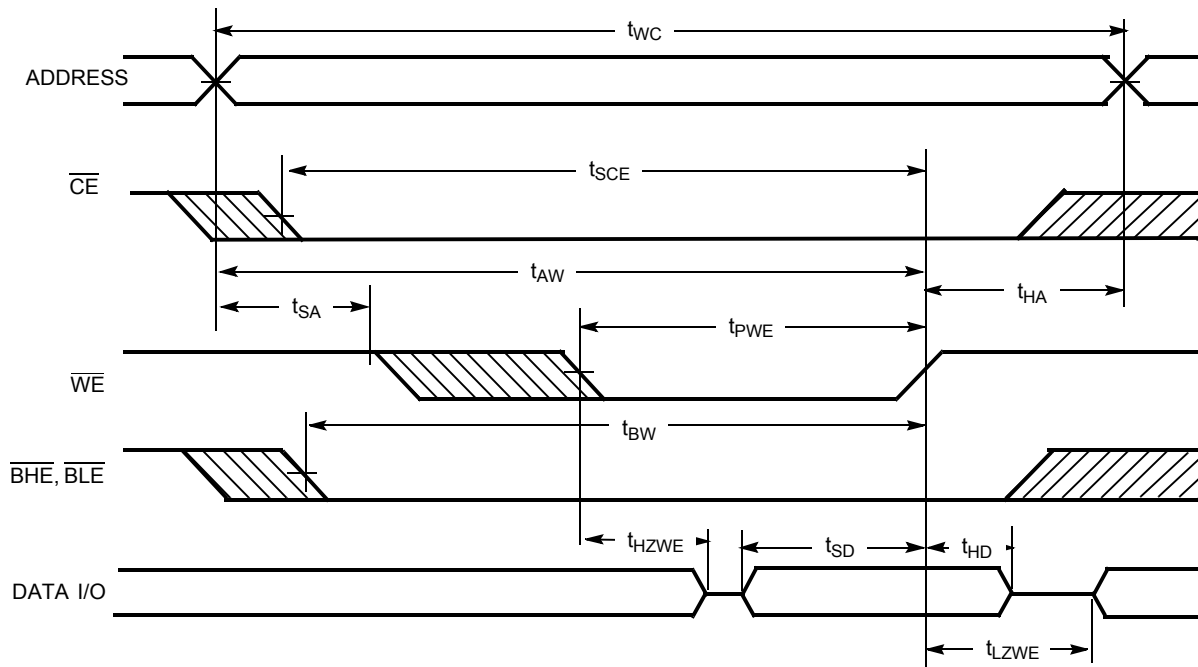

Note

16. The minimum write pulse width for Write Cycle No. 3 (\overline{WE} Controlled, \overline{OE} LOW) should be sum of t_{SD} and t_{HZWE} .

Truth Table

$\overline{\text{CE}}$	$\overline{\text{OE}}$	$\overline{\text{WE}}$	$\overline{\text{BLE}}$	$\overline{\text{BHE}}$	I/O ₁ –I/O ₈	I/O ₉ –I/O ₁₆	Mode	Power
H	X	X	X	X	High Z	High Z	Power-down	Standby (I _{SB})
L	L	H	L	L	Data out	Data out	Read – All bits	Active (I _{CC})
			L	H	Data out	High Z	Read – Lower bits only	Active (I _{CC})
			H	L	High Z	Data out	Read – Upper bits only	Active (I _{CC})
L	X	L	L	L	Data in	Data in	Write – All bits	Active (I _{CC})
			L	H	Data in	High Z	Write – Lower bits only	Active (I _{CC})
			H	L	High Z	Data in	Write – Upper bits only	Active (I _{CC})
L	H	H	X	X	High Z	High Z	Selected, outputs disabled	Active (I _{CC})
L	X	X	H	H	High Z	High Z	Selected, outputs disabled	Active (I _{CC})

Ordering Information

Speed (ns)	Ordering Code	Package Diagram	Package Type	Operating Range
15	CY7C1020CV33-15ZSX E	51-85087	44-pin TSOP Type II (Pb-free)	Automotive
	CY7C1020CV33-15ZSX ET	51-85087	44-pin TSOP Type II (Pb-free)	Automotive

Ordering Code Definitions

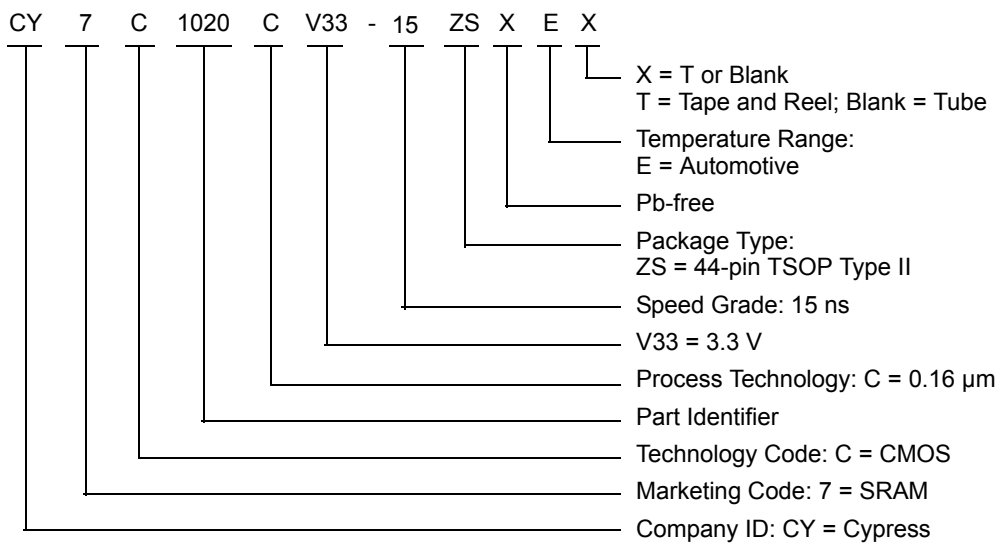

Package Diagrams

Figure 8. 44-pin TSOP Z44-II Package Outline, 51-85087

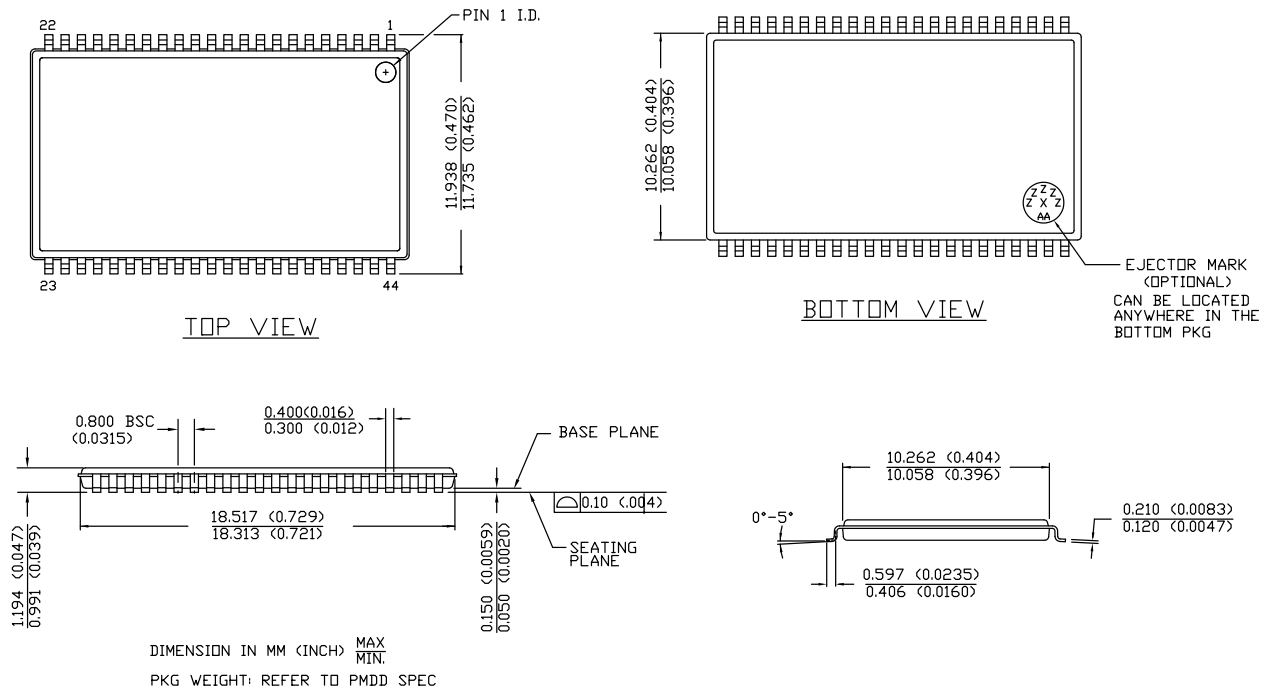

51-85087 *E

Acronyms

Acronym	Description
CMOS	Complementary Metal Oxide Semiconductor
$\overline{\text{CE}}$	Chip Enable
I/O	Input/Output
$\overline{\text{OE}}$	Output Enable
SRAM	Static Random Access Memory
TSOP	Thin Small-Outline Package
TTL	Transistor-Transistor Logic
$\overline{\text{WE}}$	Write Enable

Document Conventions

Units of Measure

Symbol	Unit of Measure
°C	degree Celsius
MHz	megahertz
μA	microampere
mA	milliampere
mW	milliwatt
ns	nanosecond
%	percent
pF	picofarad
V	volt
W	watt

Document History Page

Document Title: CY7C1020CV33, 512 K (32 K × 16) Static RAM				
Document Number: 38-05133				
Rev.	ECN No.	Issue Date	Orig. of Change	Description of Change
**	109428	12/16/01	HGK	New data sheet.
*A	115045	05/30/02	HGK	Added 8 ns speed bin related information in all instances across the document. Updated Selection Guide : Changed value of “Maximum Operating Current” corresponding to 10 ns speed bin from 100 mA to 90 mA. Changed value of “Maximum Operating Current” corresponding to 12 ns speed bin from 100 mA to 85 mA. Changed value of “Maximum Operating Current” corresponding to 15 ns speed bin from 100 mA to 80 mA. Updated Electrical Characteristics : Changed maximum value of I _{CC} parameter corresponding to 10 ns speed bin from 100 mA to 90 mA. Changed maximum value of I _{CC} parameter corresponding to 12 ns speed bin from 100 mA to 85 mA. Changed maximum value of I _{CC} parameter corresponding to 15 ns speed bin from 100 mA to 80 mA. Changed maximum value of I _{SB1} parameter corresponding to 10 ns, 12 ns and 15 ns speed bins from 40 mA to 15 mA. Updated Ordering Information : Updated part numbers.
*B	117615	08/14/02	DFP	Removed SOJ package related information in all instances across the document. Removed 8 ns speed bin related information in all instances across the document. Updated Pin Configuration : Updated Figure 1 (Replaced “A ₄ ” with “NC” for pin 1 and replaced “NC” with “A ₄ ” for pin 18). Updated Ordering Information : Updated part numbers.
*C	262949	See ECN	RKF	Added Automotive Temperature Range related information in all instances across the document. Updated Ordering Information : Updated part numbers.
*D	334398	See ECN	SYT	Updated Ordering Information : Updated part numbers (Added Lead-Free Product Information).
*E	493543	See ECN	NXR	Updated Pin Configuration : Added Note 1 and referred the same note in Figure 1 . Updated Electrical Characteristics : Changed the description of I _{IX} parameter from “Input Load Current” to “Input Leakage Current”. Removed I _{OS} parameter and its details. Updated Ordering Information : Updated part numbers.
*F	2897691	03/23/2010	RAME	Updated Ordering Information : Updated part numbers. Updated Package Diagrams .
*G	3057593	10/13/2010	PRAS	Updated Ordering Information : Updated part numbers. Added Ordering Code Definitions .

Document History Page *(continued)*

Document Title: CY7C1020CV33, 512 K (32 K × 16) Static RAM Document Number: 38-05133				
Rev.	ECN No.	Issue Date	Orig. of Change	Description of Change
*H	3100106	12/02/2010	PRAS	Minor edits across the document. Added Acronyms and Units of Measure . Updated to new template.
*I	4146968	10/04/2013	VINI	Updated Package Diagrams : spec 51-85087 – Changed revision from *C to *E. Updated to new template. Completing Sunset Review.
*J	4567799	11/12/2014	VINI	Updated Functional Description : Added “For a complete list of related resources, click here .” at the end. Updated Switching Characteristics : Added Note 10 and referred the same note in “Write Cycle”. Updated Switching Waveforms : Added Note 16 and referred the same note in Figure 7 . Completing Sunset Review.
*K	4573200	11/18/2014	VINI	No technical updates.
*L	5004033	11/05/2015	VINI	Updated to new template. Completing Sunset Review.

Sales, Solutions, and Legal Information

Worldwide Sales and Design Support

Cypress maintains a worldwide network of offices, solution centers, manufacturer's representatives, and distributors. To find the office closest to you, visit us at [Cypress Locations](#).

Products

Automotive	cypress.com/go/automotive
Clocks & Buffers	cypress.com/go/clocks
Interface	cypress.com/go/interface
Lighting & Power Control	cypress.com/go/powerpsoc
Memory	cypress.com/go/memory
PSoC	cypress.com/go/psoc
Touch Sensing	cypress.com/go/touch
USB Controllers	cypress.com/go/USB
Wireless/RF	cypress.com/go/wireless

PSoC[®] Solutions

psoc.cypress.com/solutions
PSoC 1 | PSoC 3 | PSoC 4 | PSoC 5LP

Cypress Developer Community

[Community](#) | [Forums](#) | [Blogs](#) | [Video](#) | [Training](#)

Technical Support

cypress.com/go/support

© Cypress Semiconductor Corporation, 2001-2015. The information contained herein is subject to change without notice. Cypress Semiconductor Corporation assumes no responsibility for the use of any circuitry other than circuitry embodied in a Cypress product. Nor does it convey or imply any license under patent or other rights. Cypress products are not warranted nor intended to be used for medical, life support, life saving, critical control or safety applications, unless pursuant to an express written agreement with Cypress. Furthermore, Cypress does not authorize its products for use as critical components in life-support systems where a malfunction or failure may reasonably be expected to result in significant injury to the user. The inclusion of Cypress products in life-support systems application implies that the manufacturer assumes all risk of such use and in doing so indemnifies Cypress against all charges.

Any Source Code (software and/or firmware) is owned by Cypress Semiconductor Corporation (Cypress) and is protected by and subject to worldwide patent protection (United States and foreign), United States copyright laws and international treaty provisions. Cypress hereby grants to licensee a personal, non-exclusive, non-transferable license to copy, use, modify, create derivative works of, and compile the Cypress Source Code and derivative works for the sole purpose of creating custom software and or firmware in support of licensee product to be used only in conjunction with a Cypress integrated circuit as specified in the applicable agreement. Any reproduction, modification, translation, compilation, or representation of this Source Code except as specified above is prohibited without the express written permission of Cypress.

Disclaimer: CYPRESS MAKES NO WARRANTY OF ANY KIND, EXPRESS OR IMPLIED, WITH REGARD TO THIS MATERIAL, INCLUDING, BUT NOT LIMITED TO, THE IMPLIED WARRANTIES OF MERCHANTABILITY AND FITNESS FOR A PARTICULAR PURPOSE. Cypress reserves the right to make changes without further notice to the materials described herein. Cypress does not assume any liability arising out of the application or use of any product or circuit described herein. Cypress does not authorize its products for use as critical components in life-support systems where a malfunction or failure may reasonably be expected to result in significant injury to the user. The inclusion of Cypress' product in a life-support systems application implies that the manufacturer assumes all risk of such use and in doing so indemnifies Cypress against all charges.

Use may be limited by and subject to the applicable Cypress software license agreement.

X-ON Electronics

Largest Supplier of Electrical and Electronic Components

Click to view similar products for [SRAM](#) category:

Click to view products by [Cypress](#) manufacturer:

Other Similar products are found below :

[CY6116A-35DMB](#) [CY7C1049GN-10VXI](#) [CY7C128A-45DMB](#) [GS8161Z36DD-200I](#) [GS88237CB-200I](#) [RMLV0408EGSB-4S2#AA0](#)
[IDT70V5388S166BG](#) [IS64WV3216BLL-15CTLA3](#) [IS66WVE4M16ECLL-70BLI](#) [PCF8570P](#) [K6F2008V2E-LF70000](#) [K6T4008C1B-GB70](#)
[CY7C1353S-100AXC](#) [AS6C8016-55BIN](#) [AS7C164A-15PCN](#) [515712X](#) [IDT71V67603S133BG](#) [IS62WV51216EBLL-45BLI](#)
[IS63WV1288DBLL-10HLI](#) [IS66WVE2M16ECLL-70BLI](#) [70V639S10BCG](#) [IS66WVE4M16EALL-70BLI](#) [IS62WV6416DBLL-45BLI](#)
[IS61WV102416DBLL-10TLI](#) [CY7C1381KV33-100AXC](#) [CY7C1381KVE33-133AXI](#) [8602501XA](#) [5962-3829425MUA](#) [5962-3829430MUA](#)
[5962-8855206YA](#) [5962-8866201YA](#) [5962-8866204TA](#) [5962-8866206MA](#) [5962-8866208UA](#) [5962-8872502XA](#) [5962-9062007MXA](#) [5962-](#)
[9161705MXA](#) [70V3579S6BFI](#) [GS882Z18CD-150I](#) [M38510/28902BVA](#) [8413202RA](#) [5962-9161708MYA](#) [5962-8971203XA](#) [5962-](#)
[8971202ZA](#) [5962-8872501LA](#) [5962-8866208YA](#) [5962-8866205YA](#) [5962-8866205UA](#) [5962-8866203YA](#) [5962-8855202YA](#)