

Features

- Fast access time: 15 ns
- Wide voltage range: 5.0 V ± 10% (4.5 V to 5.5 V)
- complementary metal oxide semiconductor (CMOS) for optimum speed and power
- Transistor transistor logic (TTL) compatible inputs and outputs
- 2.0 V data retention
- Low CMOS standby power
- Automated power-down when deselected
- Available in Pb-free 28-pin molded small outline J-lead (SOJ) and 28-pin DIP packages

General Description ^[1]

The CY7C199CN is a high performance CMOS Asynchronous SRAM organized as 32K by 8 bits that supports an asynchronous memory interface. The device features an automatic power-down feature that reduces power consumption when deselected.

See the "Truth Table" on page 4 in this data sheet for a complete description of read and write modes.

The CY7C199CN is available in 28-pin molded SOJ and 28-pin DIP package(s).

Logic Block Diagram

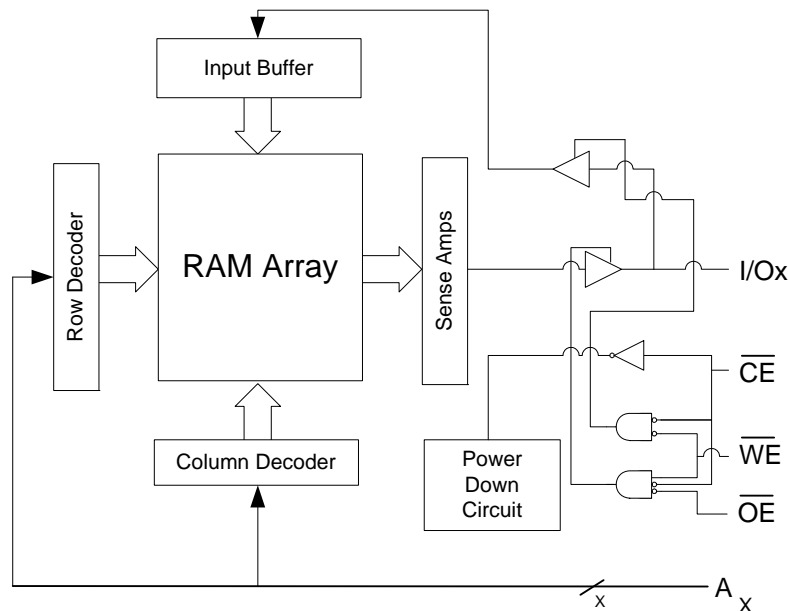

Product Portfolio

	-15	Unit
Maximum access time	15	ns
Maximum operating current	80	mA
Maximum CMOS standby current (low power)	500	μA

Contents

Pin Layout and Specifications	3	Ordering Information	12
Pin Description	4	Ordering Code Definitions	12
Truth Table	4	Package Diagrams	13
Maximum Ratings	4	Acronyms	15
Operating Range	4	Document Conventions	15
Capacitance	5	Units of Measure	15
Thermal Resistance	5	Document History Page	16
DC Electrical Characteristics	5	Sales, Solutions, and Legal Information	17
AC Test Loads	6	Worldwide Sales and Design Support	17
AC Test Conditions	6	Products	17
AC Electrical Characteristics	7	PSoC Solutions	17
Data Retention Characteristics	7		

Pin Layout and Specifications

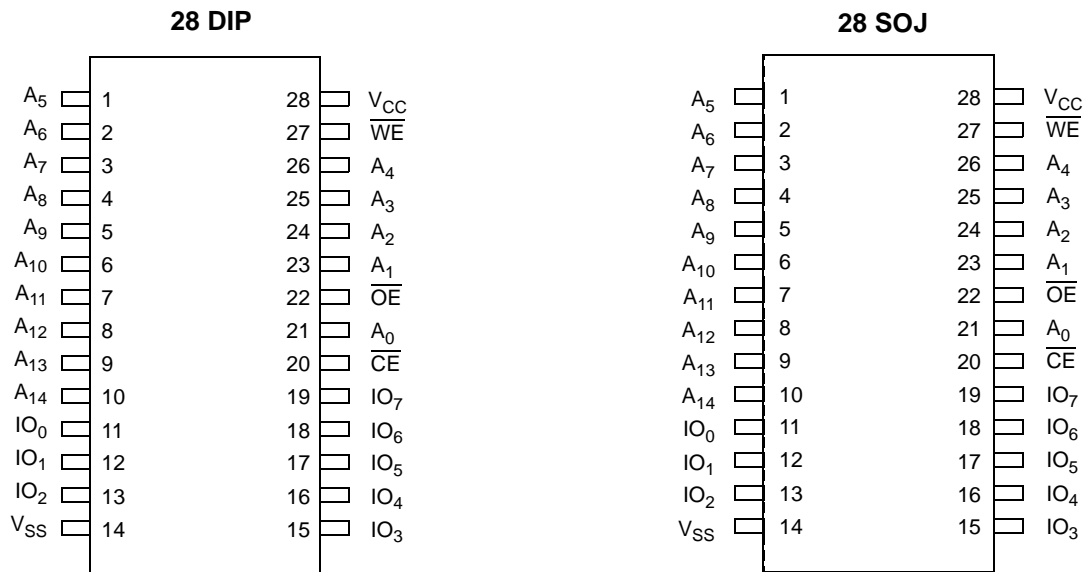

Note

1. For best practices recommendations, refer to the Cypress application note *System Design Guidelines* on www.cypress.com.

Pin Description

Pin	Type	Description	DIP	SOJ
A _X	Input	Address inputs	1, 2, 3, 4, 5, 6, 7, 8, 9, 10, 21, 23, 24, 25, 26	1, 2, 3, 4, 5, 6, 7, 8, 9, 10, 21, 23, 24, 25, 26
$\overline{\text{CE}}$	Control	Chip enable	20	20
IO _X	Input or Output	Data input outputs	11, 12, 13, 15, 16, 17, 18, 19	11, 12, 13, 15, 16, 17, 18, 19
$\overline{\text{OE}}$	Control	Output enable	22	22
V _{CC}	Supply	Power (5.0V)	28	28
V _{SS}	Supply	Ground	14	14
$\overline{\text{WE}}$	Control	Write enable	27	27

Truth Table

$\overline{\text{CE}}$	$\overline{\text{OE}}$	$\overline{\text{WE}}$	IO _X	Mode	Power
H	X	X	High-Z	Deselect/Power-down	Stand by (I _{SB})
L	L	H	Data Out	Read	Active (I _{CC})
L	X	L	Data In	Write	Active (I _{CC})
L	H	H	High-Z	Selected, Outputs disabled	Active (I _{CC})

Maximum Ratings

Exceeding maximum ratings may shorten the useful life of the device. User guidelines are not tested.

Parameter	Description	Value	Unit
T _{STG}	Storage temperature	-65 to +150	°C
T _{AMB}	Ambient temperature with power applied (that is, case temperature)	-55 to +125	°C
V _{CC}	Core Supply voltage relative to V _{SS}	-0.5 to +7.0	V
V _{IN} , V _{OUT}	DC voltage applied to any pin relative to V _{SS}	-0.5 to V _{CC} + 0.5	V
I _{OUT}	Output short-circuit current	20	mA
V _{ESD}	Static discharge voltage (in accordance with MIL-STD-883, Method 3015)	> 2001	V
I _{LU}	Latch-up current	> 200	mA

Operating Range

Range	Ambient Temperature (T _A)	Voltage Range (V _{CC})
Commercial	0 °C to 70 °C	5.0 V ± 10%
Industrial	-40 °C to 85 °C	5.0 V ± 10%

DC Electrical Characteristics

Over the Operating Range ^[2]

Parameter	Description	Condition	-15		Unit
			Min	Max	
V _{IH}	Input HIGH voltage		2.2	V _{CC} + 0.3	V
V _{IL}	Input LOW voltage		-0.5	0.8	V
V _{OH}	Output HIGH voltage	V _{CC} = Min, I _{OH} = -4.0 mA	2.4	-	V
V _{OL}	Output LOW voltage	V _{CC} = Min, I _{OL} = 8.0 mA	-	0.4	V
I _{CC}	V _{CC} Operating supply current	V _{CC} = Max, I _{OUT} = 0 mA, f = F _{max} = 1/t _{RC}	-	80	mA
I _{SB1}	Automatic \overline{CE} power-down current TTL inputs	Max V _{CC} , $\overline{CE} \geq V_{IH}$, V _{IN} ≥ V _{IH} or V _{IN} ≤ V _{IL} , f = F _{max}		30	mA
			L	10	mA
I _{SB2}	Automatic \overline{CE} power-down current CMOS Inputs	Max V _{CC} , $\overline{CE} \geq V_{CC} - 0.3$ V, V _{IN} ≥ V _{CC} - 0.3 V, or V _{IN} ≤ 0.3 V, f = 0		10	mA
			L	500	μA
I _{OZ}	Output leakage current	GND ≤ V _I ≤ V _{CC} , output disabled	-5	+5	μA
I _{IX}	Input leakage current	GND ≤ V _I ≤ V _{CC}	-5	+5	μA

Capacitance

Parameter ^[3]	Description	Conditions	Max	Unit
C _{IN}	Input capacitance	T _A = 25°C, f = 1 MHz, V _{CC} = 5.0 V	8	pF
C _{OUT}	Output capacitance		8	

Thermal Resistance

Parameter ^[3]	Description	Conditions	SOJ	DIP	Unit
θ _{JA}	Thermal resistance (junction to ambient)	Still air, soldered on a 3 × 4.5 square inch, two-layer printed circuit board	79	69.33	°C/W
θ _{JC}	Thermal resistance (junction to case)		41.42	31.62	

Note

2. V_{IL} (min) = -2.0 V for pulse durations of less than 20 ns.

AC Test Loads

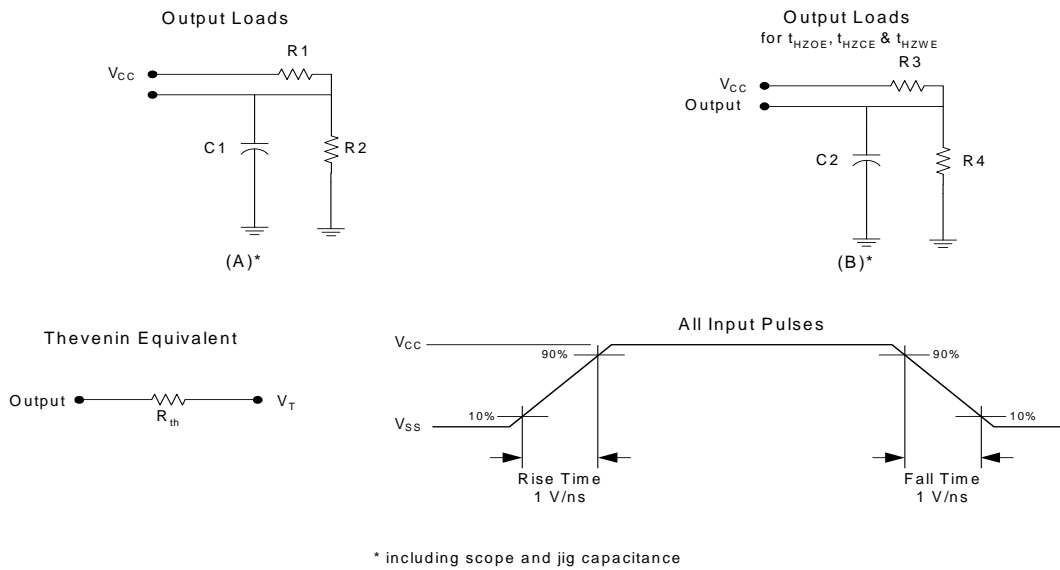

AC Test Conditions

Parameter	Description	Nom	Unit
C1	Capacitor 1	30	pF
C2	Capacitor 2	5	
R1	Resistor 1	480	Ω
R2	Resistor 2	255	
R3	Resistor 3	480	
R4	Resistor 4	255	
R _{TH}	Resistor Thevenin	167	
V _{TH}	Voltage Thevenin	1.73	V

Note

3. Tested initially and after any design or process change that may affect these parameters.

AC Electrical Characteristics

Parameter ^[4]	Description	-15		Unit
		Min	Max	
t _{RC}	Read cycle time	15	–	ns
t _{AA}	Address to data valid	–	15	ns
t _{OHA}	Data hold from address change	3	–	ns
t _{ACE}	\overline{CE} to data valid	–	15	ns
t _{DOE}	\overline{OE} to data valid	–	7	ns
t _{LZOE}	\overline{OE} to Low-Z ^[5]	0	–	ns
t _{HZOE}	\overline{OE} to High-Z ^[5, 6]	–	7	ns
t _{LZCE}	\overline{CE} to Low-Z ^[5]	3	–	ns
t _{HZCE}	\overline{CE} to High-Z ^[5, 6]	–	7	ns
t _{PU}	\overline{CE} to Power-up	0	–	ns
t _{PD}	\overline{CE} to Power-down	–	15	ns
t _{WC}	Write Cycle Time ^[7]	15	–	ns
t _{SCE}	\overline{CE} to write end	10	–	ns
t _{AW}	Address setup to write end	10	–	ns
t _{HA}	Address hold from write end	0	–	ns
t _{SA}	Address setup to write start	0	–	ns
t _{PWE}	\overline{WE} pulse width	9	–	ns
t _{SD}	Data setup to write end	9	–	ns
t _{HD}	Data hold from write end	0	–	ns
t _{HZWE}	\overline{WE} LOW to High-Z ^[5, 6]	–	7	ns
t _{LZWE}	\overline{WE} HIGH to Low-Z ^[5]	3	–	ns

Data Retention Characteristics

Parameter ^[8]	Description	Condition	Min	Max	Unit
V _{DR}	V _{CC} for data retention		2.0	–	V
I _{CCDR}	Data retention current	V _{CC} = V _{DR} = 2.0 V, $\overline{CE} \geq V_{CC} - 0.3$ V, V _{IN} ≥ V _{CC} – 0.3 V or V _{IN} ≤ 0.3 V	–	150	μA
t _{CDR}	Chip deselect to data retention time		0	–	ns
t _R	Operation recovery time		200	–	μs

Notes

- Test Conditions are based on a transition time of 3 ns or less and timing reference levels of 1.5 V, and input pulse levels of 0 to 3.0 V.
- At any given temperature and voltage condition, t_{HZCE} is less than t_{LZCE}, t_{HZOE} is less than t_{LZOE}, and t_{HZWE} is less than t_{LZWE} for any given device.
- t_{HZOE}, t_{HZCE}, t_{HZWE} are specified as in part (b) of the "" on page 5. Transitions are measured ± 200 mV from steady state voltage.
- The internal memory write time is defined by the overlap of \overline{CE} LOW and \overline{WE} LOW. \overline{CE} and \overline{WE} must be LOW to initiate a write, and the transition of any of these signals can terminate the write. The input data setup and hold timing must be referenced to the leading edge of the signal that terminates the write.
- L-version only.

Timing Waveforms

Data Retention Waveform

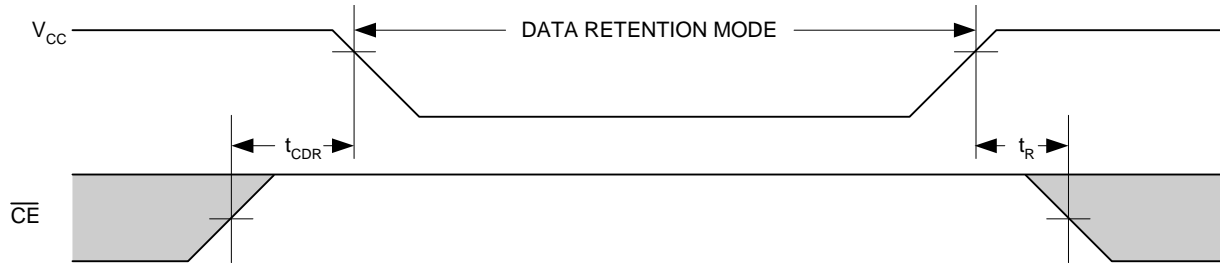
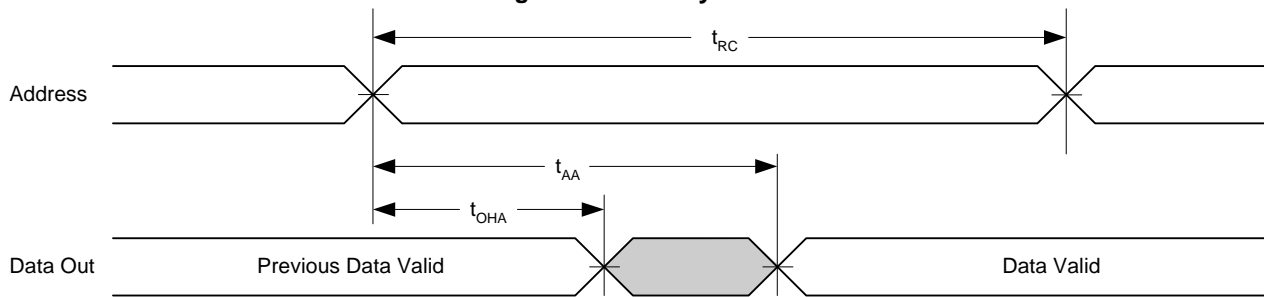

Figure 1. Read Cycle 1 [9, 10]



Notes

9. Device is continuously selected. $\overline{OE} = V_{IL} = \overline{CE}$.
10. \overline{WE} is HIGH for read cycle.

Timing Waveforms (continued)

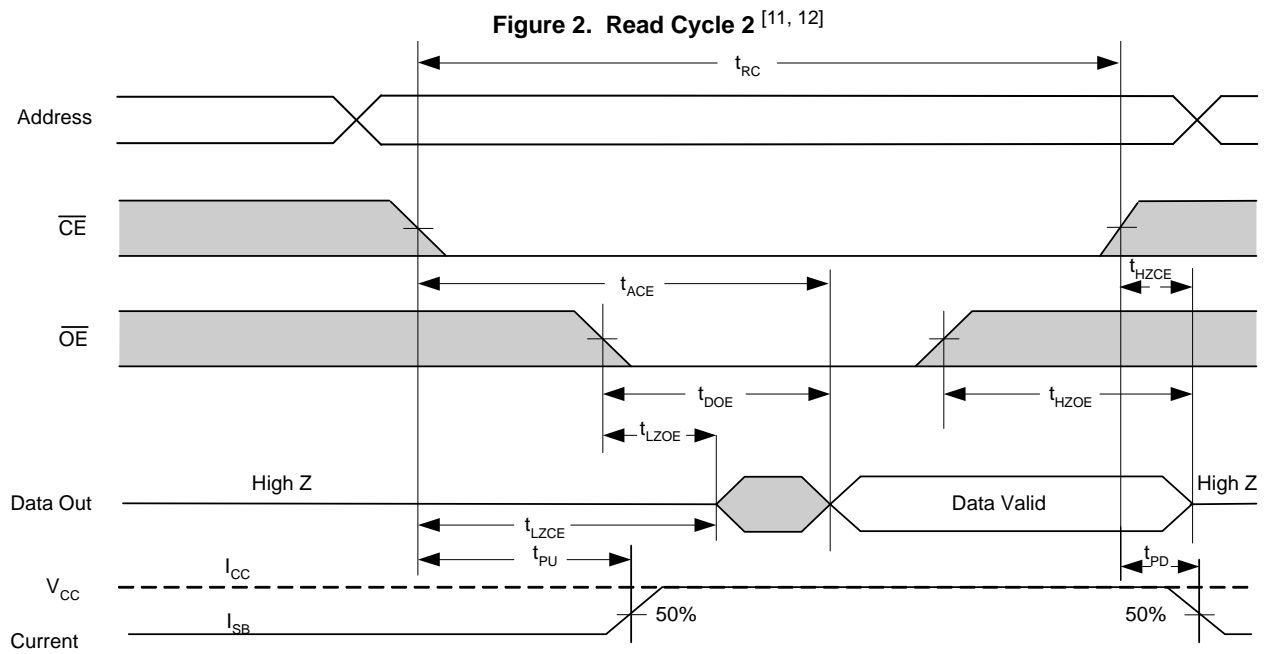

Notes

- 11. This cycle is \overline{OE} controlled and \overline{WE} is HIGH read cycle.
- 12. Address valid before or similar with \overline{CE} transition LOW.

Timing Waveforms (continued)

Figure 3. Write Cycle 1 (\overline{WE} controlled) [13, 14, 15]

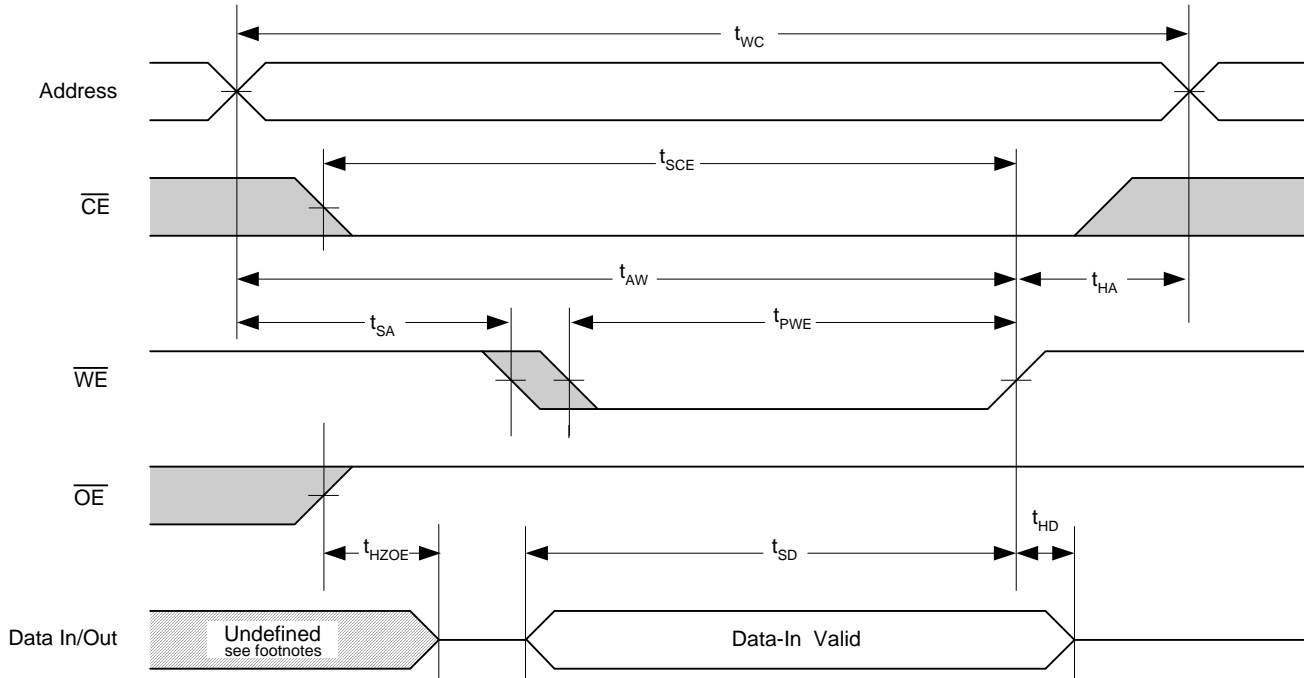
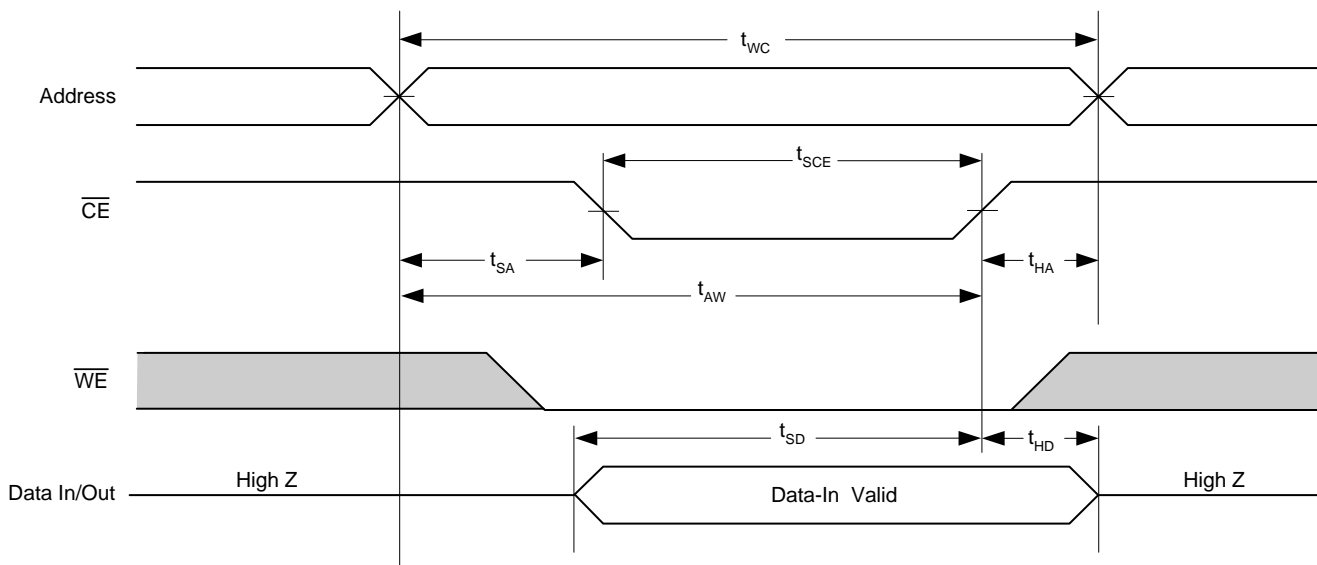

Figure 4. Write Cycle 2 (\overline{CE} controlled) [14, 16, 17]



Notes

- 13. This cycle is \overline{WE} controlled, \overline{OE} is HIGH during write.
- 14. Data in and/or out is high impedance if $\overline{OE} = V_{IH}$.
- 15. During this period the IOs are in output state and input signals must not be applied.
- 16. This cycle is \overline{CE} controlled.
- 17. If \overline{CE} goes HIGH simultaneously with \overline{WE} going HIGH, the output remains in a high impedance state.

Timing Waveforms (continued)

Figure 5. Write Cycle 3 (\overline{WE} controlled, \overline{OE} low) [18]

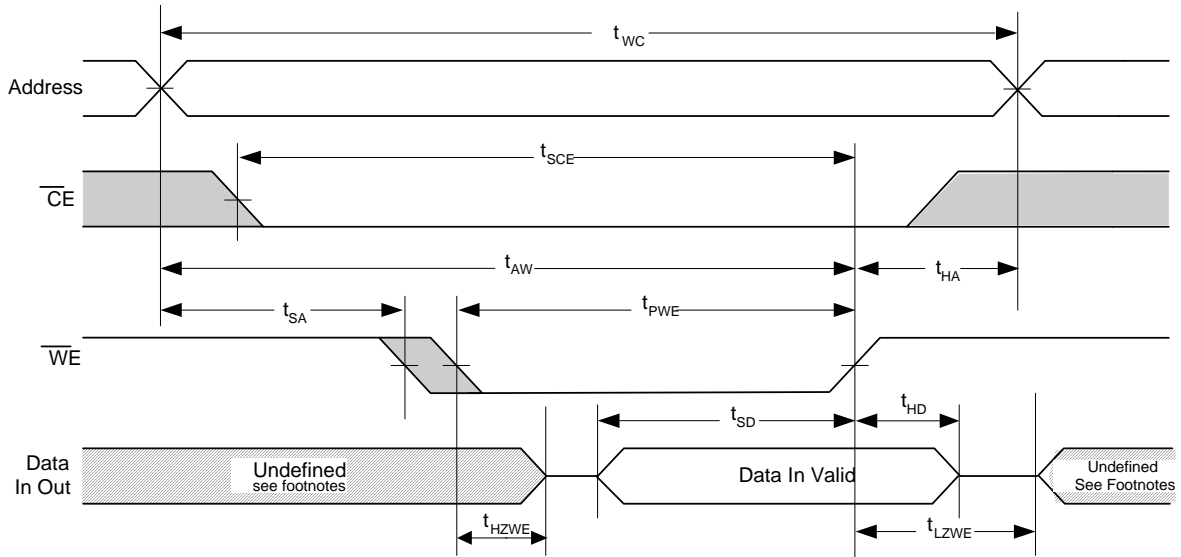

Note

18. The cycle is \overline{WE} controlled, \overline{OE} LOW. The minimum write cycle time is the sum of t_{HZWE} and t_{SD} .

Ordering Information

Contact local sales representative regarding availability of these parts.

Speed (ns)	Ordering Code	Package Diagram	Package Type	Power Option	Operating Range
15	CY7C199CN-15PXC	51-85014	28 DIP (6.9 × 35.6 × 3.5 mm), Pb-free	Standard	Commercial
	CY7C199CNL-15VXI	51-85031	28-Pin (300-Mil) Molded SOJ, Pb-free	Low Power	Industrial

Ordering Code Definitions

CY 7 C 1 99 CN L - XX XX X

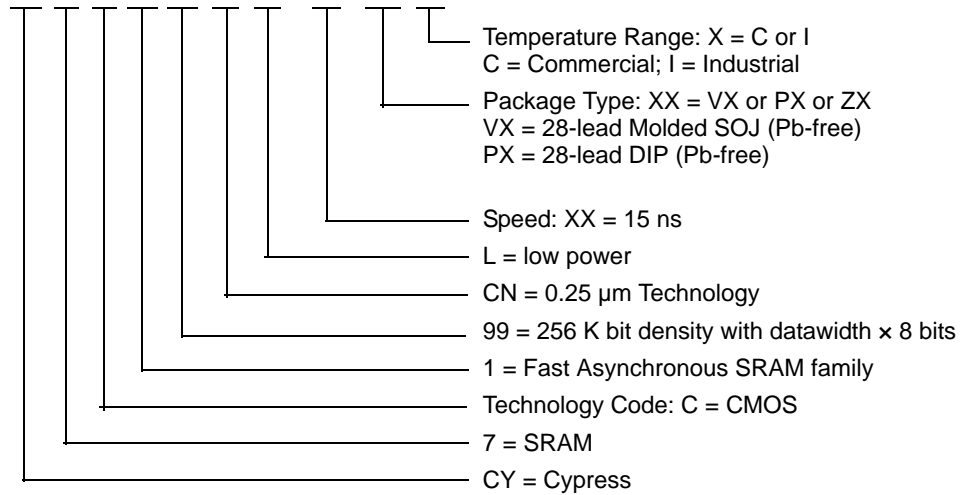

Package Diagrams

Figure 6. 28-pin (300 Mil) Molded SOJ, 51-85031

NOTE :

1. JEDEC STD REF MD088
2. BODY LENGTH DIMENSION DOES NOT INCLUDE MOLD PROTRUSION/END FLASH
MOLD PROTRUSION/END FLASH SHALL NOT EXCEED 0.006 in (0.152 mm) PER SIDE
3. DIMENSIONS IN INCHES MIN.
MAX.

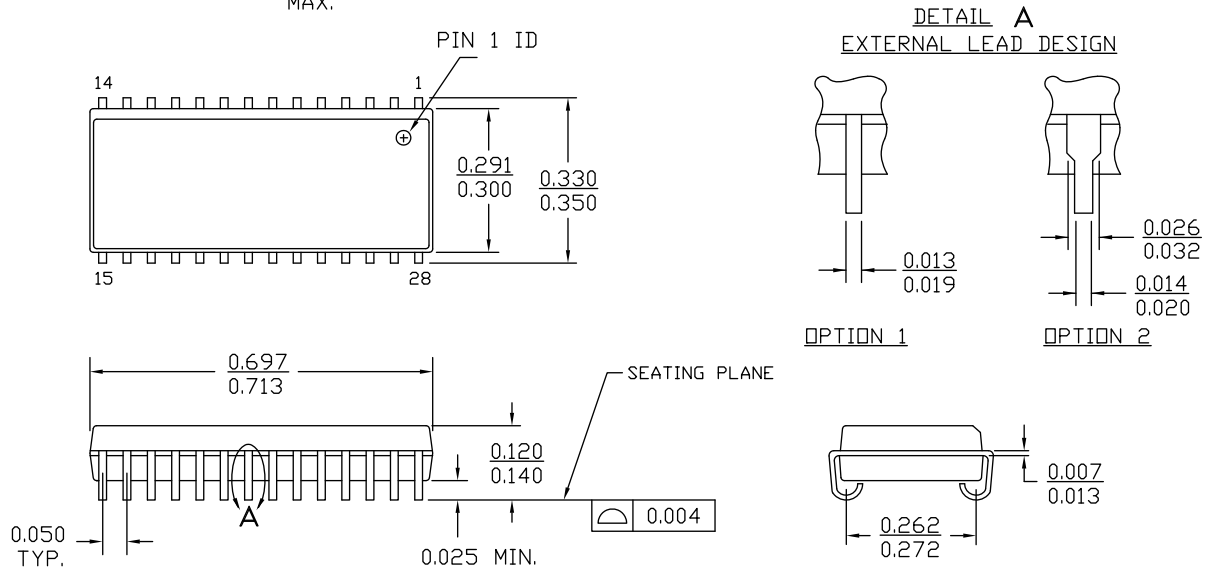

51-85031 *E

Package Diagrams (continued)

Figure 7. 28-pin (300 Mil) PDIP, 51-85014

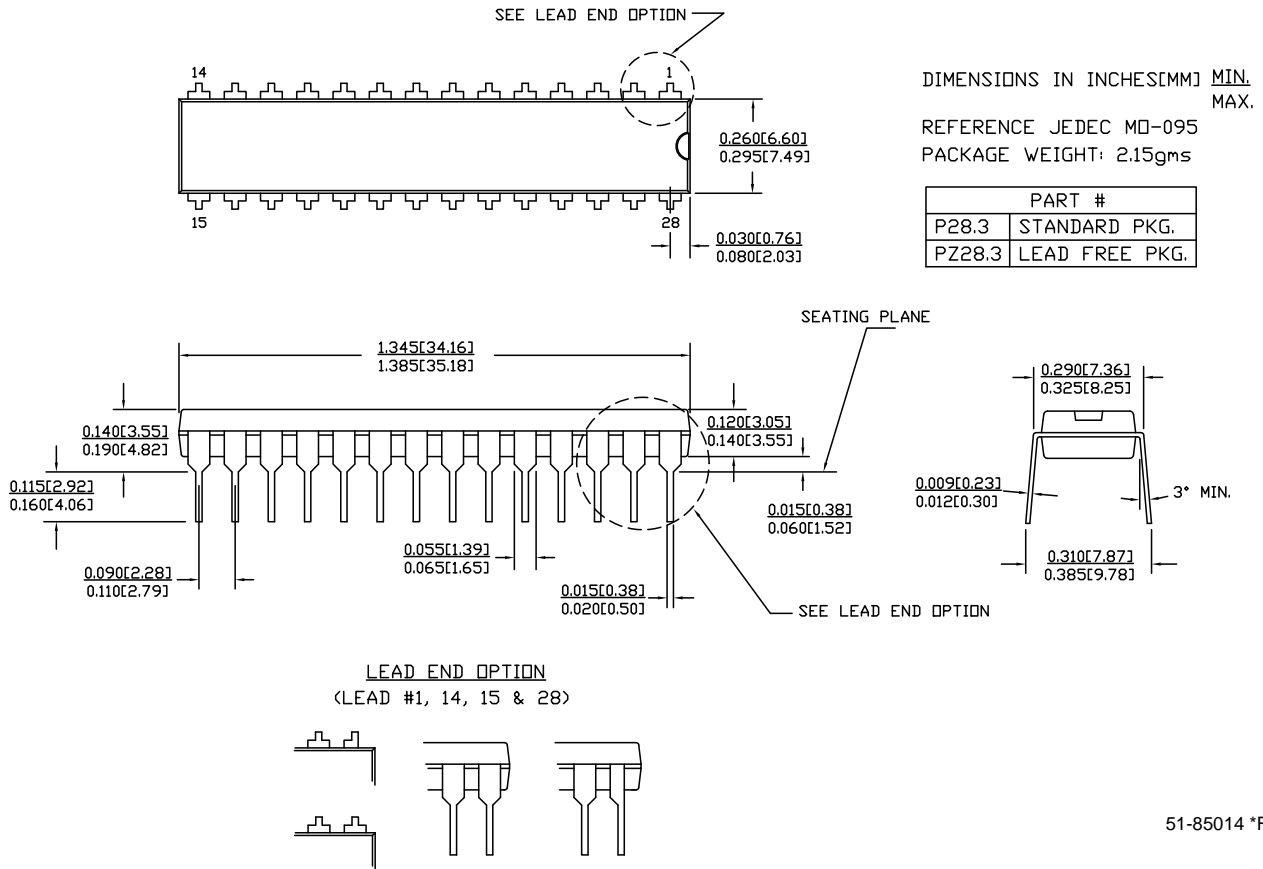

51-85014 *F

Acronyms

Acronym	Description
CE	chip enable
CMOS	complementary metal oxide semiconductor
I/O	input/output
OE	output enable
SRAM	static random access memory
SOJ	small outline j-lead
VFBGA	very fine-pitch ball grid array

Document Conventions

Units of Measure

Symbol	Unit of Measure
ns	nanosecond
V	volt
μA	microampere
mA	milliampere
mV	millivolt
mW	milliwatt
MHz	megahertz
pF	picoFarad
°C	degree Celsius
W	Watt

Document History Page

Document Title: CY7C199CN, 256 K (32 K x 8) Static RAM Document Number: 001-06435				
Revision	ECN	Submission Date	Orig. of Change	Description of Change
**	430363	See ECN	NXR	New Data Sheet
*A	684342	See ECN	VKN	Added Automotive-A Information Updated Ordering Information Table
*B	839904	See ECN	VKN	Added t_{DOE} spec for Automotive-A part in AC Electrical characteristics table
*C	2896044	03/19/2010	NXR	Updated Ordering Information Table Updated Package Diagram
*D	3108898	12/13/2010	PRAS	Added Ordering Code Definitions .
*E	3198636	03/17/11	PRAS	Dislodged Automotive device information to 001-67737 Updated template and styles.
*F	3246329	05/04/2011	PRAS	Additional information on ISB1, ISB2 with respect to L parts
*G	3302830	08/02/2011	RAME	Removed the following parts from ordering information table. CY7C199CN-15VXC CY7C199CN-20ZXI Removed all information related to 28-pin TSOP 1. Removed all information related to 20 ns speed bin. Removed spec 51-85071.

Sales, Solutions, and Legal Information

Worldwide Sales and Design Support

Cypress maintains a worldwide network of offices, solution centers, manufacturer's representatives, and distributors. To find the office closest to you, visit us at [Cypress Locations](#).

Products

Automotive	cypress.com/go/automotive
Clocks & Buffers	cypress.com/go/clocks
Interface	cypress.com/go/interface
Lighting & Power Control	cypress.com/go/powerpsoc cypress.com/go/plc
Memory	cypress.com/go/memory
Optical & Image Sensing	cypress.com/go/image
PSoC	cypress.com/go/psoc
Touch Sensing	cypress.com/go/touch
USB Controllers	cypress.com/go/USB
Wireless/RF	cypress.com/go/wireless

PSoC Solutions

psoc.cypress.com/solutions
PSoC 1 | PSoC 3 | PSoC 5

© Cypress Semiconductor Corporation, 2006-2011. The information contained herein is subject to change without notice. Cypress Semiconductor Corporation assumes no responsibility for the use of any circuitry other than circuitry embodied in a Cypress product. Nor does it convey or imply any license under patent or other rights. Cypress products are not warranted nor intended to be used for medical, life support, life saving, critical control or safety applications, unless pursuant to an express written agreement with Cypress. Furthermore, Cypress does not authorize its products for use as critical components in life-support systems where a malfunction or failure may reasonably be expected to result in significant injury to the user. The inclusion of Cypress products in life-support systems application implies that the manufacturer assumes all risk of such use and in doing so indemnifies Cypress against all charges.

Any Source Code (software and/or firmware) is owned by Cypress Semiconductor Corporation (Cypress) and is protected by and subject to worldwide patent protection (United States and foreign), United States copyright laws and international treaty provisions. Cypress hereby grants to licensee a personal, non-exclusive, non-transferable license to copy, use, modify, create derivative works of, and compile the Cypress Source Code and derivative works for the sole purpose of creating custom software and or firmware in support of licensee product to be used only in conjunction with a Cypress integrated circuit as specified in the applicable agreement. Any reproduction, modification, translation, compilation, or representation of this Source Code except as specified above is prohibited without the express written permission of Cypress.

Disclaimer: CYPRESS MAKES NO WARRANTY OF ANY KIND, EXPRESS OR IMPLIED, WITH REGARD TO THIS MATERIAL, INCLUDING, BUT NOT LIMITED TO, THE IMPLIED WARRANTIES OF MERCHANTABILITY AND FITNESS FOR A PARTICULAR PURPOSE. Cypress reserves the right to make changes without further notice to the materials described herein. Cypress does not assume any liability arising out of the application or use of any product or circuit described herein. Cypress does not authorize its products for use as critical components in life-support systems where a malfunction or failure may reasonably be expected to result in significant injury to the user. The inclusion of Cypress' product in a life-support systems application implies that the manufacturer assumes all risk of such use and in doing so indemnifies Cypress against all charges.

Use may be limited by and subject to the applicable Cypress software license agreement.

X-ON Electronics

Largest Supplier of Electrical and Electronic Components

Click to view similar products for [SRAM](#) category:

Click to view products by [Cypress](#) manufacturer:

Other Similar products are found below :

[CY6116A-35DMB](#) [CY7C1049GN-10VXI](#) [CY7C128A-45DMB](#) [GS8161Z36DD-200I](#) [GS88237CB-200I](#) [RMLV0408EGSB-4S2#AA0](#)
[IDT70V5388S166BG](#) [IS64WV3216BLL-15CTLA3](#) [IS66WVE4M16ECLL-70BLI](#) [PCF8570P](#) [K6F2008V2E-LF70000](#) [K6T4008C1B-GB70](#)
[CY7C1353S-100AXC](#) [AS6C8016-55BIN](#) [AS7C164A-15PCN](#) [515712X](#) [IDT71V67603S133BG](#) [IS62WV51216EBLL-45BLI](#)
[IS63WV1288DBLL-10HLI](#) [IS66WVE2M16ECLL-70BLI](#) [70V639S10BCG](#) [IS66WVE4M16EALL-70BLI](#) [IS62WV6416DBLL-45BLI](#)
[IS61WV102416DBLL-10TLI](#) [CY7C1381KV33-100AXC](#) [CY7C1381KVE33-133AXI](#) [8602501XA](#) [5962-3829425MUA](#) [5962-3829430MUA](#)
[5962-8855206YA](#) [5962-8866201YA](#) [5962-8866204TA](#) [5962-8866206MA](#) [5962-8866208UA](#) [5962-8872502XA](#) [5962-9062007MXA](#) [5962-](#)
[9161705MXA](#) [70V3579S6BFI](#) [GS882Z18CD-150I](#) [M38510/28902BVA](#) [8413202RA](#) [5962-9161708MYA](#) [5962-8971203XA](#) [5962-](#)
[8971202ZA](#) [5962-8872501LA](#) [5962-8866208YA](#) [5962-8866205YA](#) [5962-8866205UA](#) [5962-8866203YA](#) [5962-8855202YA](#)