

FMB MB9A140NA Series

32-bit ARM™ Cortex™-M3 based Microcontroller
MB9AF141LA/MA/NA, MB9AF142LA/MA/NA,
MB9AF144LA/MA/NA

Data Sheet (Full Production)



FM3 MB9A140NA Series

32-bit ARM™ Cortex™-M3 based Microcontroller
MB9AF141LA/MA/NA, MB9AF142LA/MA/NA,
MB9AF144LA/MA/NA

Data Sheet (Full Production)



■ DESCRIPTION

The MB9A140NA Series are highly integrated 32-bit microcontrollers dedicated for embedded controllers with low-power consumption mode and competitive cost.

These series are based on the ARM Cortex-M3 Processor with on-chip Flash memory and SRAM, and have peripheral functions such as various timers, ADCs, and Communication Interfaces (UART, CSIO, I²C).

The products which are described in this data sheet are placed into TYPE6 product categories in "FM3 Family PERIPHERAL MANUAL".

Note: ARM and Cortex are the trademarks of ARM Limited in the EU and other countries.



Publication Number MB9A140NA_DS706-00040

Revision 2.1

Issue Date January 31, 2014

This document states the current technical specifications regarding the Spansion product(s) described herein. Spansion Inc. deems the products to have been in sufficient production volume such that subsequent versions of this document are not expected to change. However, typographical or specification corrections, or modifications to the valid combinations offered may occur.

CONFIDENTIAL

■ FEATURES

- 32-bit ARM Cortex-M3 Core
 - Processor version: r2p1
 - Up to 40 MHz Frequency Operation
 - Integrated Nested Vectored Interrupt Controller (NVIC): 1 NMI (non-maskable interrupt) and 48 peripheral interrupts and 16 priority levels
 - 24-bit System timer (Sys Tick): System timer for OS task management

- On-chip Memories

[Flash memory]

- Dual operation Flash memory
 - Dual Operation Flash memory has the upper bank and the lower bank. So, this series could implement erase, write and read operations for each bank simultaneously.
 - Main area: Up to 256 Kbytes (Up to 240Kbytes upper bank + 16Kbytes lower bank)
 - Work area: 32 Kbytes (lower bank)
- Read cycle: 0 wait-cycle
- Security function for code protection

[SRAM]

This Series on-chip SRAM is composed of two independent SRAM (SRAM0, SRAM1). SRAM0 is connected to I-code bus or D-code bus of Cortex-M3 core. SRAM1 is connected to System bus.

- SRAM0: Up to 16 Kbytes
- SRAM1: Up to 16 Kbytes

- External Bus Interface*

- Supports SRAM, NOR Flash memory device
- Up to 8 chip selects
- 8/16-bit Data width
- Up to 25-bit Address bit
- Supports Address/Data multiplex
- Supports external RDY function
- * : MB9AF141LA, F142LA and F144LA do not support External Bus Interface.

- Multi-function Serial Interface (Max 8channels)

- 4 channels with 16steps×9-bit FIFO (ch.4 to ch.7), 4 channels without FIFO (ch.0 to ch.3)
- Operation mode is selectable from the followings for each channel.
 - UART
 - CSIO
 - I²C

[UART]

- Full-duplex double buffer
- Selection with or without parity supported
- Built-in dedicated baud rate generator
- External clock available as a serial clock
- Hardware Flow control* : Automatically control the transmission by CTS/RTS (only ch.4)
- Various error detection functions available (parity errors, framing errors, and overrun errors)
- * : MB9AF141LA, F142LA and F144LA do not support Hardware Flow control.

[CSIO]

- Full-duplex double buffer
- Built-in dedicated baud rate generator
- Overrun error detection function available

[I²C]

Standard mode (Max 100kbps) / High-speed mode (Max 400kbps) supported

- **DMA Controller (8channels)**

The DMA Controller has an independent bus from the CPU, so CPU and DMA Controller can process simultaneously.

- 8 independently configured and operated channels
- Transfer can be started by software or request from the built-in peripherals
- Transfer address area: 32-bit (4 Gbytes)
- Transfer mode: Block transfer/Burst transfer/Demand transfer
- Transfer data type: byte/half-word/word
- Transfer block count: 1 to 16
- Number of transfers: 1 to 65536

- **A/D Converter (Max 24channels)**

[12-bit A/D Converter]

- Successive Approximation type
- Built-in 2units
- Conversion time: 2.0 μ s @ 2.7V to 3.6V
- Priority conversion available (priority at 2levels)
- Scanning conversion mode
- Built-in FIFO for conversion data storage (for SCAN conversion: 16steps, for Priority conversion: 4steps)

- **Base Timer (Max 8channels)**

Operation mode is selectable from the followings for each channel.

- 16-bit PWM timer
- 16-bit PPG timer
- 16/32-bit reload timer
- 16/32-bit PWC timer

- **General-Purpose I/O Port**

This series can use its pins as general-purpose I/O ports when they are not used for external bus or peripherals. Moreover, the port relocate function is built in. It can set which I/O port the peripheral function can be allocated to.

- Capable of pull-up control per pin
 - Capable of reading pin level directly
 - Built-in the port relocate function
 - Up to 83 fast general-purpose I/O Ports@100pin Package
 - Some ports are 5V tolerant I/O.
- See "■PIN DESCRIPTION" to confirm the corresponding pins.

- **Dual Timer (32/16-bit Down Counter)**

The Dual Timer consists of two programmable 32/16-bit down counters. Operation mode is selectable from the followings for each channel.

- Free-running
- Periodic (=Reload)
- One-shot

- **HDMI-CEC/Remote Control Receiver (Up to 2channels)**

- HDMI-CEC transmitter
 - Header block automatic transmission by judging Signal free
 - Generating status interrupt by detecting Arbitration lost
 - Generating START, EOM, ACK automatically to output CEC transmission by setting 1 byte data
 - Generating transmission status interrupt when transmitting 1 block (1 byte data and EOM/ACK)
- HDMI-CEC receiver
 - Automatic ACK reply function available
 - Line error detection function available
- Remote control receiver
 - 4 bytes reception buffer
 - Repeat code detection function available

- **Real-time clock (RTC)**

The Real-time clock can count Year/Month/Day/Hour/Minute/Second/A day of the week from 01 to 99.

- The interrupt function with specifying date and time (Year/Month/Day/Hour/Minute/Second/A day of the week.) is available. This function is also available by specifying only Year, Month, Day, Hour or Minute.
- Timer interrupt function after set time or each set time.
- Capable of rewriting the time with continuing the time count.
- Leap year automatic count is available.

- **Watch Counter**

The Watch counter is used for wake up from sleep and timer mode.

Interval timer: up to 64s (Max) @ Sub Clock : 32.768 kHz

- **External Interrupt Controller Unit**

- Up to 16 external interrupt input pins
- Include one non-maskable interrupt (NMI) input pin

- **Watchdog Timer (2channels)**

A watchdog timer can generate interrupts or a reset when a time-out value is reached.

This series consists of two different watchdogs, a "Hardware" watchdog and a "Software" watchdog.

The "Hardware" watchdog timer is clocked by the built-in low-speed CR oscillator. Therefore, the "Hardware" watchdog is active in any low-power consumption modes except RTC, STOP, Deep standby RTC and Deep standby STOP modes.

- **CRC (Cyclic Redundancy Check) Accelerator**

The CRC accelerator calculates the CRC which has a heavy software processing load, and achieves a reduction of the integrity check processing load for reception data and storage.

CCITT CRC16 and IEEE-802.3 CRC32 are supported.

- CCITT CRC16 Generator Polynomial: 0x1021
- IEEE-802.3 CRC32 Generator Polynomial: 0x04C11DB7

- Clock and Reset

- [Clocks]

- Selectable from five clock sources (2 external oscillators, 2 built-in CR oscillators, and Main PLL).

- Main Clock : 4 MHz to 48 MHz
 - Sub Clock : 32.768 kHz
 - Built-in high-speed CR Clock : 4 MHz
 - Built-in low-speed CR Clock : 100 kHz
 - Main PLL Clock

- [Resets]

- Reset requests from INITX pin
 - Power on reset
 - Software reset
 - Watchdog timers reset
 - Low-voltage detection reset
 - Clock Super Visor reset

- Clock Super Visor (CSV)

- Clocks generated by built-in CR oscillators are used to supervise abnormality of the external clocks.

- External clock failure (clock stop) is detected, reset is asserted.
 - External frequency anomaly is detected, interrupt or reset is asserted.

- Low-Voltage Detector (LVD)

- This Series includes 2-stage monitoring of voltage on the VCC pins. When the voltage falls below the voltage that has been set, Low-Voltage Detector generates an interrupt or reset.

- LVD1: error reporting via interrupt
 - LVD2: auto-reset operation

- Low-Power Consumption Mode

- Six low-power consumption modes supported.

- SLEEP
 - TIMER
 - RTC
 - STOP
 - Deep standby RTC (selectable between keeping the value of RAM and not)
 - Deep standby STOP (selectable between keeping the value of RAM and not)

- Debug

- Serial Wire JTAG Debug Port (SWJ-DP)
 - Embedded Trace Macrocells (ETM).*
- *: MB9AF141LA/MA, F142LA/MA and F144LA/MA support only SWJ-DP.

- Unique ID

- Unique value of the device (41-bit) is set.

- Power Supply

- Wide range voltage: VCC = 1.65V to 3.6V

■ PRODUCT LINEUP

● Memory size

Product name		MB9AF141LA/MA/NA	MB9AF142LA/MA/NA	MB9AF144LA/MA/NA
On-chip Flash memory	Main area	64 Kbytes	128 Kbytes	256 Kbytes
	Work area	32 Kbytes	32 Kbytes	32 Kbytes
On-chip SRAM	SRAM0	8 Kbytes	8 Kbytes	16 Kbytes
	SRAM1	8 Kbytes	8 Kbytes	16 Kbytes
	Total	16 Kbytes	16 Kbytes	32 Kbytes

● Function

Product name		MB9AF141LA MB9AF142LA MB9AF144LA	MB9AF141MA MB9AF142MA MB9AF144MA	MB9AF141NA MB9AF142NA MB9AF144NA
Pin count		64	80/96	100/112
CPU		Cortex-M3		
	Freq.	40 MHz		
Power supply voltage range		1.65V to 3.6V		
DMAC		8ch.		
External Bus Interface		-	Addr: 21-bit (Max) R/W Data: 8-bit (Max) CS: 4 (Max) Support: SRAM, NOR Flash memory	Addr: 25-bit (Max) R/W Data: 8/16-bit (Max) CS: 8 (Max) Support: SRAM, NOR Flash memory
Multi-function Serial Interface (UART/CSIO/I ² C)		8ch. (Max) ch.4 to ch.7: FIFO (16steps × 9-bit) ch.0 to ch.3: No FIFO		
Base Timer (PWC/Reload timer/PWM/PPG)		8ch. (Max)		
Dual Timer		1 unit		
HDMI-CEC/ Remote Control Receiver		2ch. (Max)		
Real-Time Clock		1 unit		
Watch Counter		1 unit		
CRC Accelerator		Yes		
Watchdog timer		1ch. (SW) + 1ch. (HW)		
External Interrupts		8pins (Max) + NMI × 1	11pins (Max) + NMI × 1	16pins (Max) + NMI × 1
I/O ports		51pins (Max)	66pins (Max)	83pins (Max)
12-bit A/D converter		12ch. (2 units)	17ch. (2 units)	24ch. (2 units)
CSV (Clock Super Visor)		Yes		
LVD (Low-Voltage Detector)		2ch.		
Built-in CR	High-speed	4 MHz (± 2%)		
	Low-speed	100 kHz (Typ)		
Debug Function		SWJ-DP		SWJ-DP/ETM
Unique ID		Yes		

Note: All signals of the peripheral function in each product cannot be allocated by limiting the pins of package.
It is necessary to use the port relocate function of the I/O port according to your function use.

■ PACKAGES

Package	Product name	MB9AF141LA	MB9AF141MA	MB9AF141NA
		MB9AF142LA	MB9AF142MA	MB9AF142NA
		MB9AF144LA	MB9AF144MA	MB9AF144NA
LQFP: FPT-64P-M38 (0.5mm pitch)		○	-	-
LQFP: FPT-64P-M39 (0.65mm pitch)		○	-	-
QFN: LCC-64P-M24 (0.5mm pitch)		○	-	-
LQFP: FPT-80P-M37 (0.5mm pitch)		-	○	-
LQFP: FPT-80P-M40 (0.65mm pitch)		-	○	-
BGA: BGA-96P-M07 (0.5mm pitch)		-	○	-
LQFP: FPT-100P-M23 (0.5mm pitch)		-	-	○
QFP: FPT-100P-M36 (0.65mm pitch)		-	-	○
BGA: BGA-112P-M04 (0.8mm pitch)		-	-	○

○ : Supported

Note: See "■PACKAGE DIMENSIONS" for detailed information on each package.

PIN ASSIGNMENT

- FPT-100P-M23

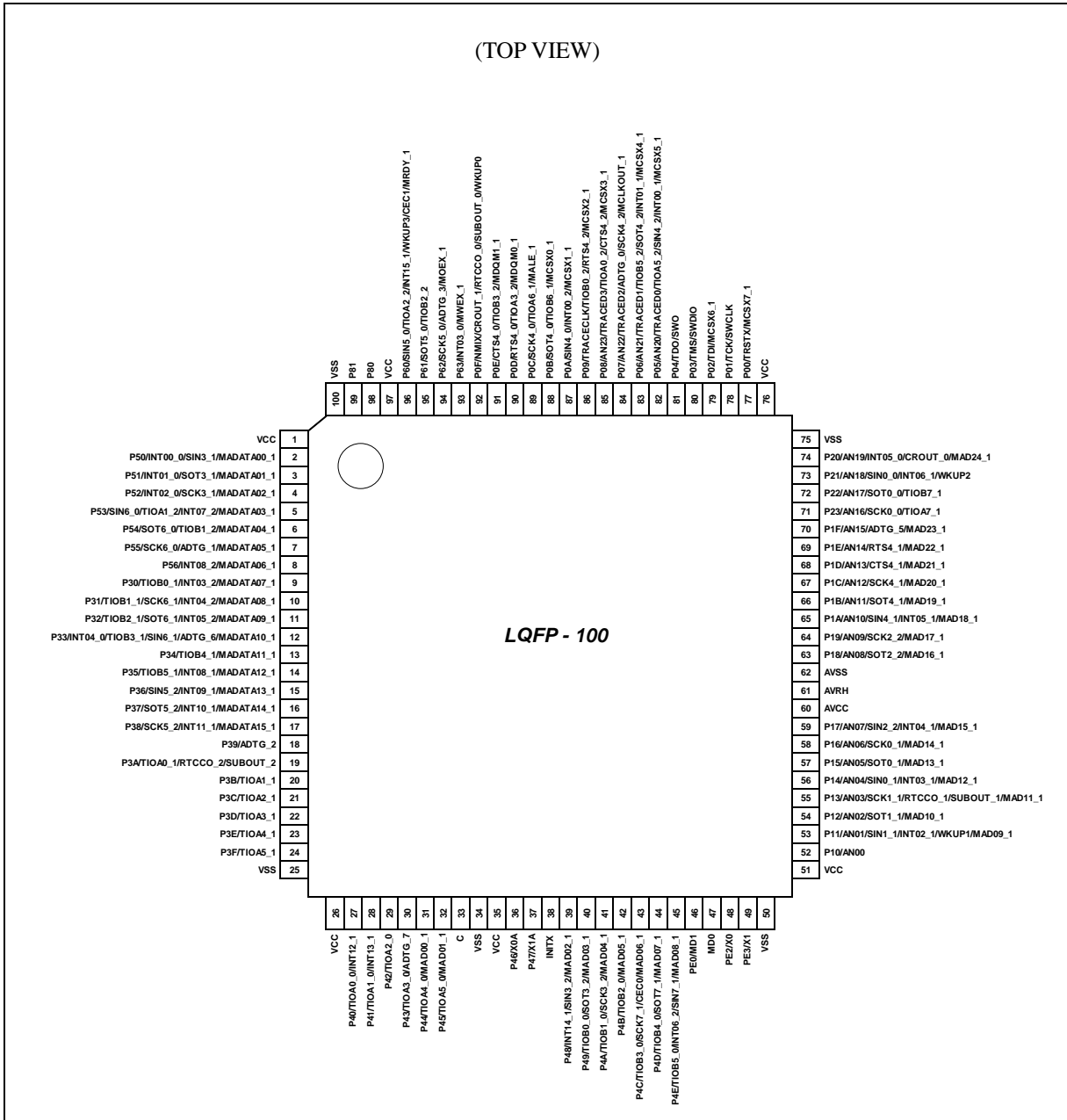

<Note>

The number after the underscore ("_") in pin names such as XXX_1 and XXX_2 indicates the relocated port number. For these pins, there are multiple pins that provide the same function for the same channel. Use the extended port function register (EPFR) to select the pin.

● FPT-100P-M36

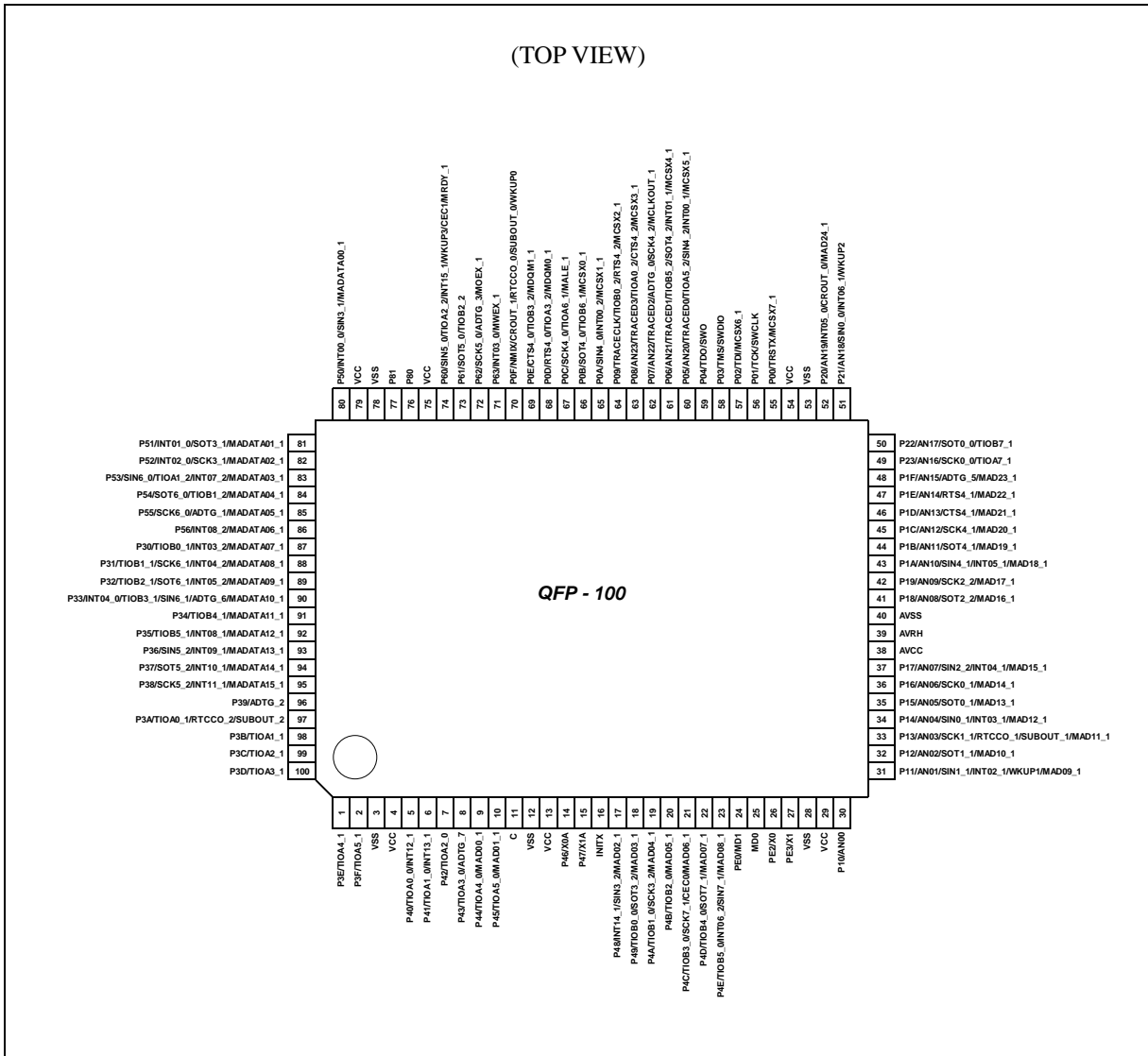

<Note>

The number after the underscore ("_") in pin names such as XXX_1 and XXX_2 indicates the relocated port number. For these pins, there are multiple pins that provide the same function for the same channel. Use the extended port function register (EPFR) to select the pin.

● FPT-80P-M37/M40

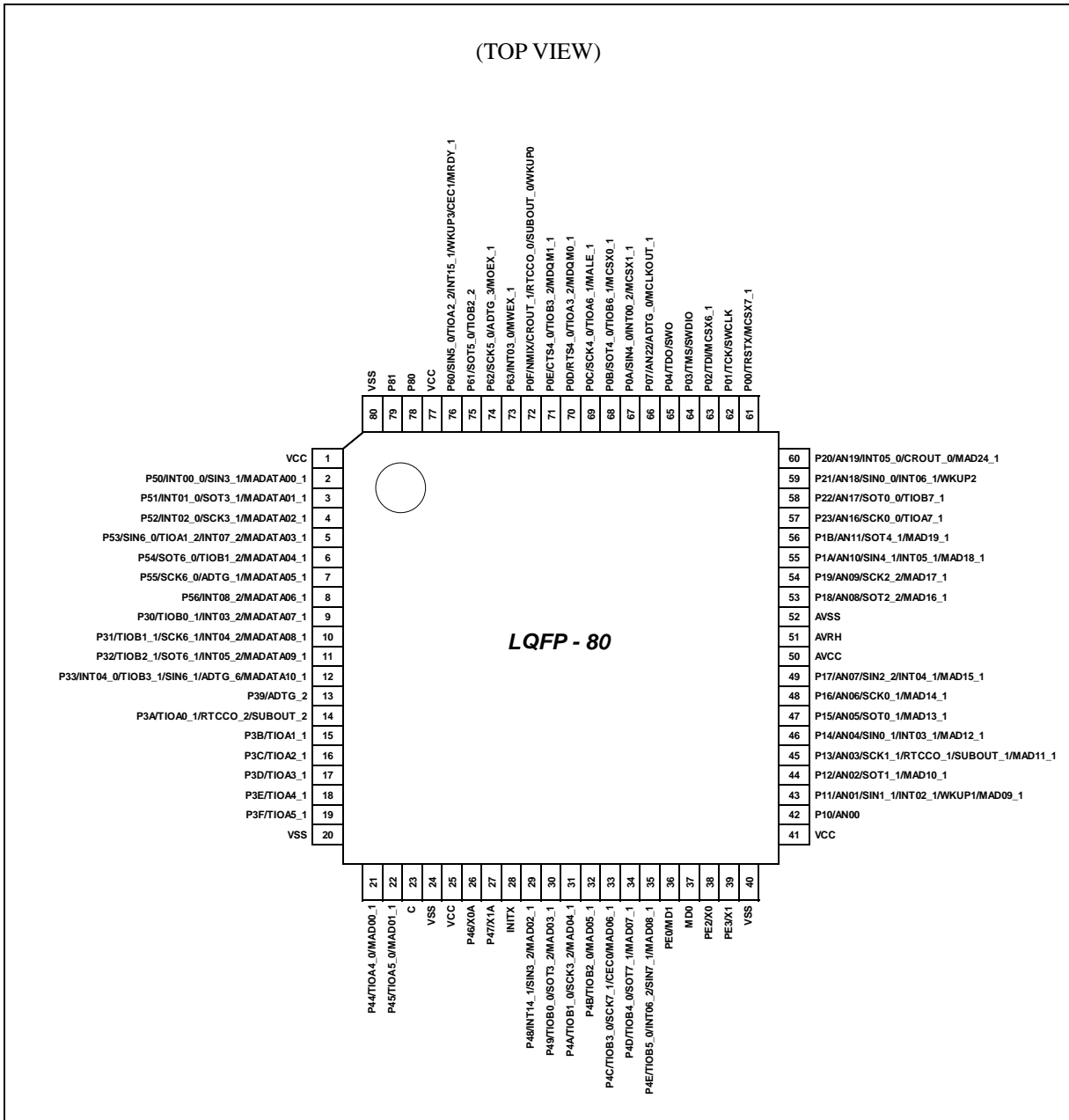

<Note>

The number after the underscore ("_") in pin names such as XXX_1 and XXX_2 indicates the relocated port number. For these pins, there are multiple pins that provide the same function for the same channel. Use the extended port function register (EPFR) to select the pin.

● FPT-64P-M38/M39

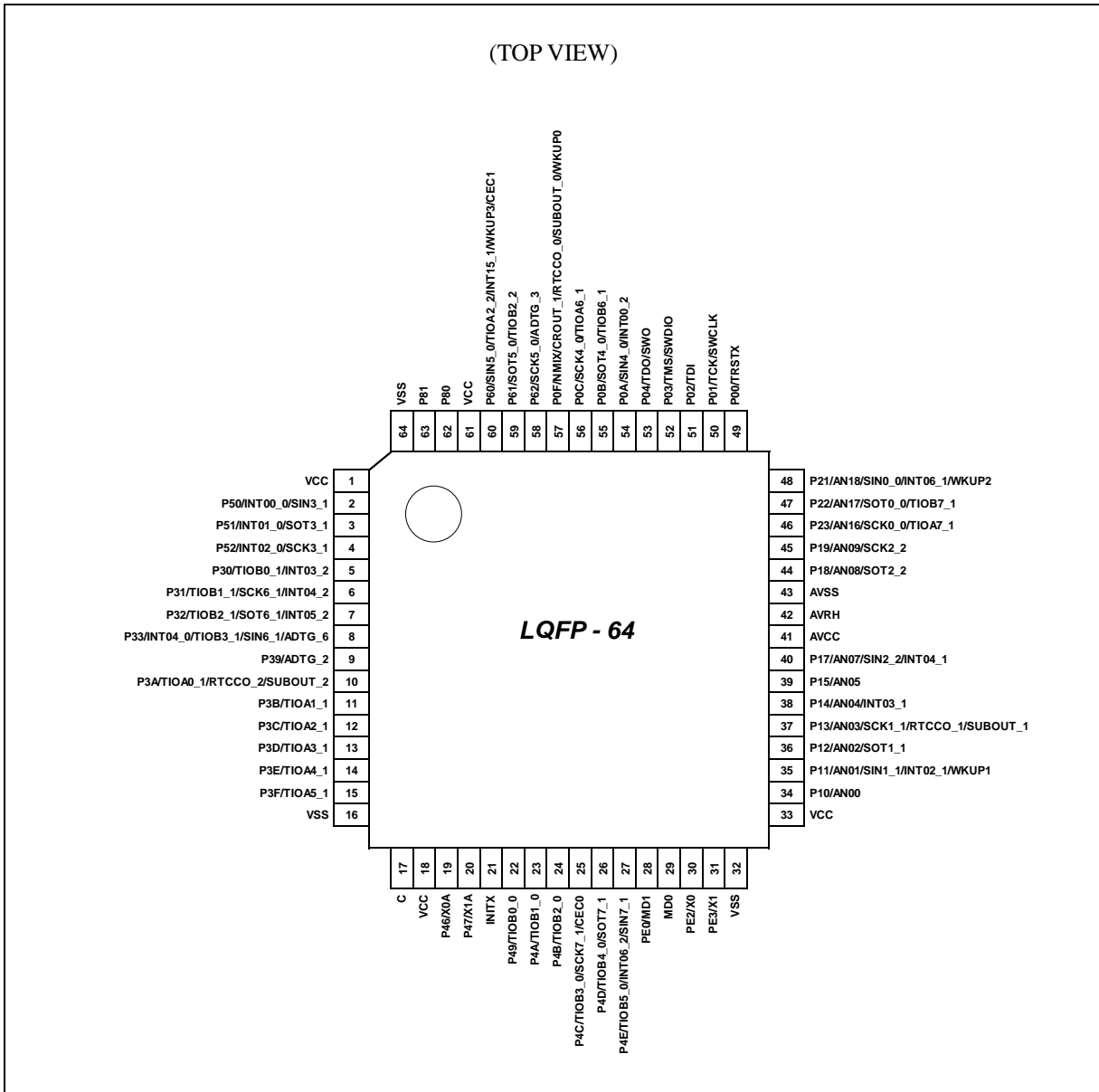

<Note>

The number after the underscore ("_") in pin names such as XXX_1 and XXX_2 indicates the relocated port number. For these pins, there are multiple pins that provide the same function for the same channel. Use the extended port function register (EPFR) to select the pin.

● LCC-64P- M24

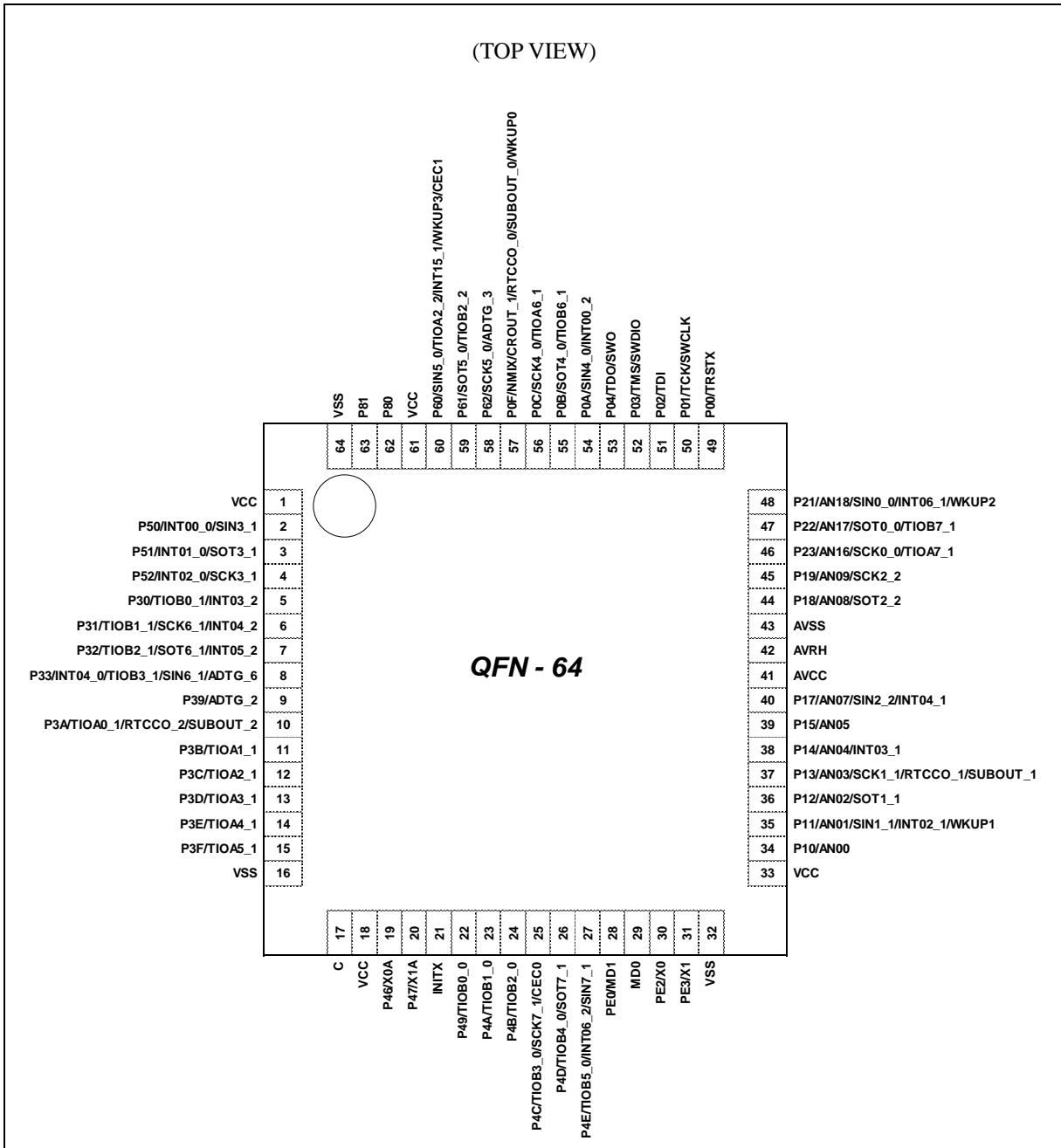

<Note>

The number after the underscore ("_") in pin names such as XXX_1 and XXX_2 indicates the relocated port number. For these pins, there are multiple pins that provide the same function for the same channel. Use the extended port function register (EPFR) to select the pin.

● BGA-112P-M04

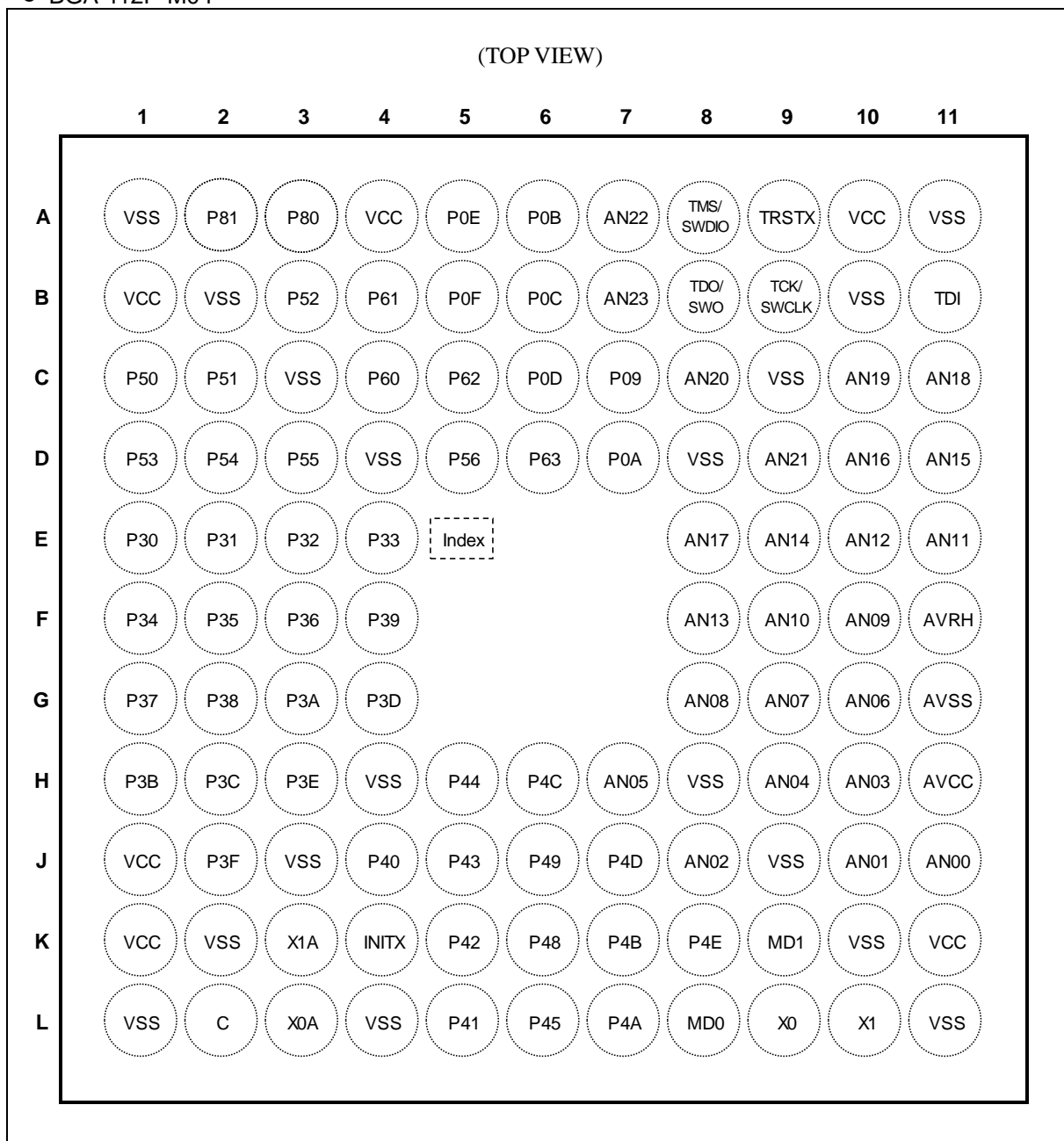

<Note>

The number after the underscore ("_") in pin names such as XXX_1 and XXX_2 indicates the relocated port number. For these pins, there are multiple pins that provide the same function for the same channel. Use the extended port function register (EPFR) to select the pin.

● BGA-96P-M07

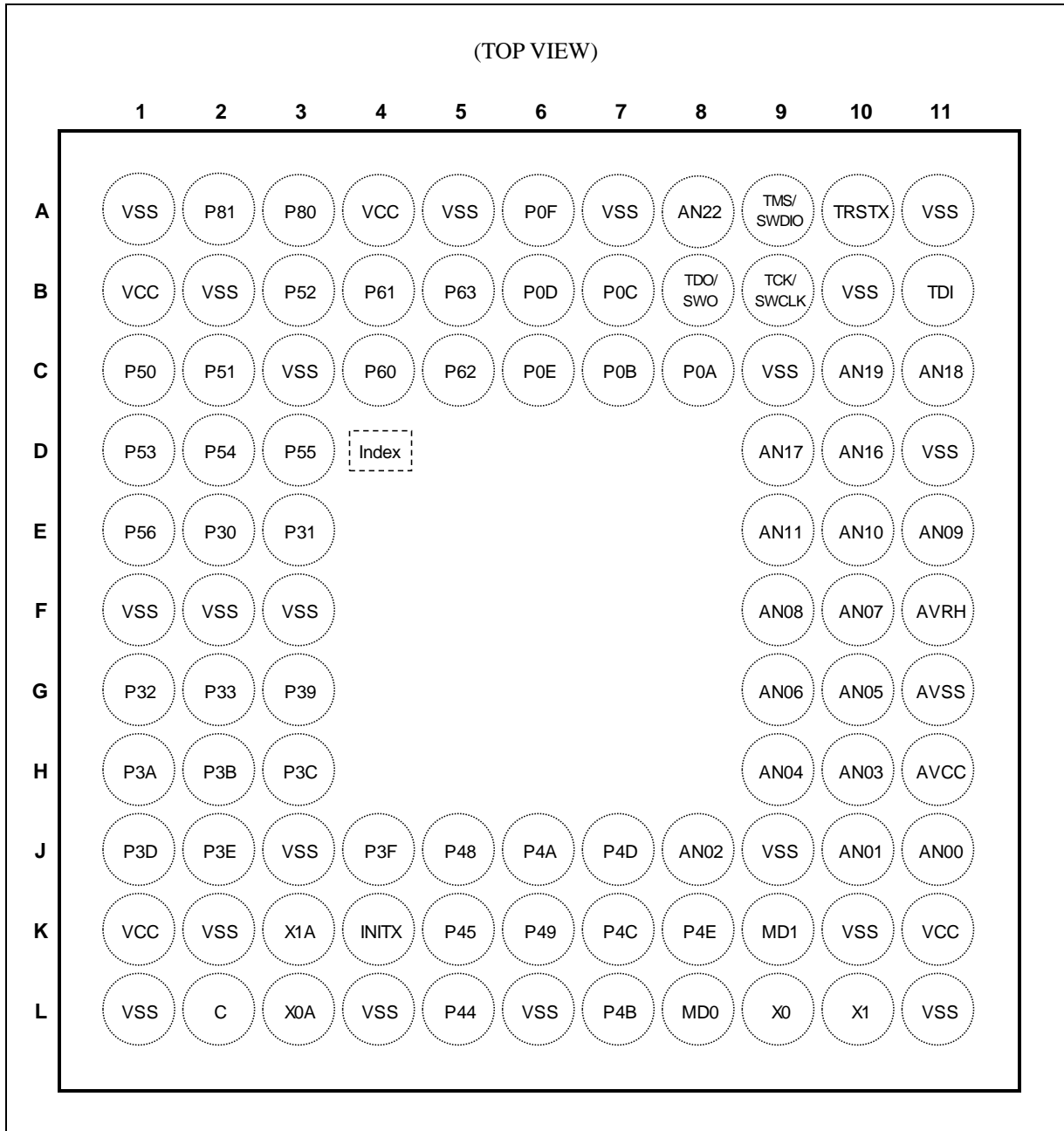

<Note>

The number after the underscore ("_") in pin names such as XXX_1 and XXX_2 indicates the relocated port number. For these pins, there are multiple pins that provide the same function for the same channel. Use the extended port function register (EPFR) to select the pin.

■ LIST OF PIN FUNCTIONS

- List of pin numbers

The number after the underscore ("_") in pin names such as XXX_1 and XXX_2 indicates the relocated port number. For these pins, there are multiple pins that provide the same function for the same channel. Use the extended port function register (EPFR) to select the pin.

Pin No						Pin Name	I/O circuit type	Pin state type
LQFP-100	QFP-100	BGA-112	LQFP-80	BGA-96	LQFP-64 QFN-64			
1	79	B1	1	B1	1	VCC	-	
2	80	C1	2	C1	2	P50	E	L
						INT00_0		
						SIN3_1		
					-	MADATA00_1		
3	81	C2	3	C2	3	P51	E	L
						INT01_0		
						SOT3_1 (SDA3_1)		
						MADATA01_1		
4	82	B3	4	B3	4	P52	E	L
						INT02_0		
						SCK3_1 (SCL3_1)		
						MADATA02_1		
5	83	D1	5	D1	-	P53	E	L
						SIN6_0		
						TIOA1_2		
						INT07_2		
						MADATA03_1		
6	84	D2	6	D2	-	P54	E	K
						SOT6_0 (SDA6_0)		
						TIOB1_2		
						MADATA04_1		

Pin No						Pin Name	I/O circuit type	Pin state type
LQFP-100	QFP-100	BGA-112	LQFP-80	BGA-96	LQFP-64 QFN-64			
7	85	D3	7	D3	-	P55	E	K
						SCK6_0 (SCL6_0)		
						ADTG_1		
						MADATAA05_1		
8	86	D5	8	E1	-	P56	E	L
						INT08_2		
						MADATAA06_1		
9	87	E1	9	E2	5	P30	E	L
					5	TIOB0_1		
						INT03_2		
					-	MADATAA07_1		
10	88	E2	10	E3	6	P31	E	L
						TIOB1_1		
						SCK6_1 (SCL6_1)		
						INT04_2		
					-	MADATAA08_1		
11	89	E3	11	G1	7	P32	E	L
						TIOB2_1		
						SOT6_1 (SDA6_1)		
						INT05_2		
					-	MADATAA09_1		
12	90	E4	12	G2	8	P33	E	L
						INT04_0		
						TIOB3_1		
						SIN6_1		
						ADTG_6		
					-	MADATAA10_1		
13	91	F1	-	-	-	P34	E	K
						TIOB4_1		
						MADATAA11_1		
14	92	F2	-	-	-	P35	E	L
						TIOB5_1		
						INT08_1		
						MADATAA12_1		

Pin No						Pin Name	I/O circuit type	Pin state type
LQFP-100	QFP-100	BGA-112	LQFP-80	BGA-96	LQFP-64 QFN-64			
15	93	F3	-	-	-	P36	E	L
						SIN5_2		
						INT09_1		
						MADATA13_1		
-	-	-	-	F1	-	VSS	-	
-	-	-	-	F2	-	VSS	-	
-	-	-	-	F3	-	VSS	-	
16	94	G1	-	-	-	P37	E	L
						SOT5_2 (SDA5_2)		
						INT10_1		
						MADATA14_1		
17	95	G2	-	-	-	P38	E	L
						SCK5_2 (SCL5_2)		
						INT11_1		
						MADATA15_1		
18	96	F4	13	G3	9	P39	E	K
						ADTG_2		
19	97	G3	14	H1	10	P3A	E	K
						TIOA0_1		
						RTCCO_2		
						SUBOUT_2		
20	98	H1	15	H2	11	P3B	E	K
						TIOA1_1		
21	99	H2	16	H3	12	P3C	E	K
						TIOA2_1		
22	100	G4	17	J1	13	P3D	E	K
						TIOA3_1		
-	-	B2	-	B2	-	VSS	-	
23	1	H3	18	J2	14	P3E	E	K
						TIOA4_1		
24	2	J2	19	J4	15	P3F	E	K
						TIOA5_1		
25	3	L1	20	L1	16	VSS	-	
26	4	J1	-	-	-	VCC	-	

Pin No						Pin Name	I/O circuit type	Pin state type
LQFP-100	QFP-100	BGA-112	LQFP-80	BGA-96	LQFP-64 QFN-64			
27	5	J4	-	-	-	P40	E	L
						TIOA0_0		
						INT12_1		
28	6	L5	-	-	-	P41	E	L
						TIOA1_0		
						INT13_1		
29	7	K5	-	-	-	P42	E	K
						TIOA2_0		
30	8	J5	-	-	-	P43	E	K
						TIOA3_0		
						ADTG_7		
31	9	H5	21	L5	-	P44	E	K
						TIOA4_0		
						MAD00_1		
32	10	L6	22	K5	-	P45	E	K
						TIOA5_0		
						MAD01_1		
-	-	K2	-	K2	-	VSS	-	-
-	-	J3	-	J3	-	VSS	-	-
-	-	H4	-	-	-	VSS	-	-
-	-	-	-	L6	-	VSS	-	-
33	11	L2	23	L2	17	C	-	-
34	12	L4	24	L4	-	VSS	-	-
35	13	K1	25	K1	18	VCC	-	-
36	14	L3	26	L3	19	P46	D	F
						X0A		
37	15	K3	27	K3	20	P47	D	G
						X1A		
38	16	K4	28	K4	21	INITX	B	C
39	17	K6	29	J5	-	P48	E	L
						INT14_1		
						SIN3_2		
						MAD02_1		
40	18	J6	30	K6	22	P49	E	K
					-	TIOB0_0		
					-	SOT3_2 (SDA3_2)		
					-	MAD03_1		

Pin No						Pin Name	I/O circuit type	Pin state type	
LQFP-100	QFP-100	BGA-112	LQFP-80	BGA-96	LQFP-64 QFN-64				
41	19	L7	31	J6	23	P4A TIOB1_0	E	K	
					-	SCK3_2 (SCL3_2) MAD04_1			
42	20	K7	32	L7	24	P4B TIOB2_0	E	K	
					-	MAD05_1			
43	21	H6	33	K7	25	P4C TIOB3_0 SCK7_1 (SCL7_1) CEC0	I	S	
						-			MAD06_1
44	22	J7	34	J7	26	P4D TIOB4_0 SOT7_1 (SDA7_1)	I	K	
					-	MAD07_1			
45	23	K8	35	K8	27	P4E TIOB5_0 INT06_2 SIN7_1	I	L	
						-			MAD08_1
46	24	K9	36	K9	28	MD1 PE0	C	E	
47	25	L8	37	L8	29	MD0	G	D	
48	26	L9	38	L9	30	X0 PE2	A	A	
49	27	L10	39	L10	31	X1 PE3	A	B	
50	28	L11	40	L11	32	VSS	-		
51	29	K11	41	K11	33	VCC	-		
52	30	J11	42	J11	34	P10 AN00	F	M	
53	31	J10	43	J10	35	P11 AN01 SIN1_1 INT02_1 WKUP1	F	R	
						-			MAD09_1

Pin No						Pin Name	I/O circuit type	Pin state type
LQFP-100	QFP-100	BGA-112	LQFP-80	BGA-96	LQFP-64 QFN-64			
54	32	J8	44	J8	36	P12	F	M
						AN02		
						SOT1_1 (SDA1_1)		
						MAD10_1		
-	-	K10	-	K10	-	VSS	-	
-	-	J9	-	J9	-	VSS	-	
55	33	H10	45	H10	37	P13	F	M
						AN03		
						SCK1_1 (SCL1_1)		
						RTCCO_1		
						SUBOUT_1		
-	MAD11_1							
56	34	H9	46	H9	38	P14	F	N
						AN04		
						INT03_1		
						SIN0_1		
-	MAD12_1							
57	35	H7	47	G10	39	P15	F	M
						AN05		
						SOT0_1 (SDA0_1)		
-	MAD13_1							
58	36	G10	48	G9	-	P16	F	M
						AN06		
						SCK0_1 (SCL0_1)		
						MAD14_1		
59	37	G9	49	F10	40	P17	F	N
						AN07		
						SIN2_2		
						INT04_1		
						-		
60	38	H11	50	H11	41	AVCC	-	
61	39	F11	51	F11	42	AVRH	-	
62	40	G11	52	G11	43	AVSS	-	

Pin No						Pin Name	I/O circuit type	Pin state type
LQFP-100	QFP-100	BGA-112	LQFP-80	BGA-96	LQFP-64 QFN-64			
63	41	G8	53	F9	44	P18	F	M
						AN08		
						SOT2_2 (SDA2_2)		
					-	MAD16_1		
64	42	F10	54	E11	45	P19	F	M
						AN09		
						SCK2_2 (SCL2_2)		
					-	MAD17_1		
-	-	H8	-	-	-	VSS	-	
65	43	F9	55	E10	-	P1A	F	N
						AN10		
						SIN4_1		
						INT05_1		
						MAD18_1		
66	44	E11	56	E9	-	P1B	F	M
						AN11		
						SOT4_1 (SDA4_1)		
						MAD19_1		
67	45	E10	-	-	-	P1C	F	M
						AN12		
						SCK4_1 (SCL4_1)		
						MAD20_1		
68	46	F8	-	-	-	P1D	F	M
						AN13		
						CTS4_1		
						MAD21_1		
69	47	E9	-	-	-	P1E	F	M
						AN14		
						RTS4_1		
						MAD22_1		
70	48	D11	-	-	-	P1F	F	M
						AN15		
						ADTG_5		
						MAD23_1		

Pin No						Pin Name	I/O circuit type	Pin state type
LQFP-100	QFP-100	BGA-112	LQFP-80	BGA-96	LQFP-64 QFN-64			
-	-	B10	-	B10	-	VSS	-	-
-	-	C9	-	C9	-	VSS	-	-
-	-	-	-	D11	-	VSS	-	-
71	49	D10	57	D10	46	P23	F	M
						AN16		
						SCK0_0 (SCL0_0)		
						TIOA7_1		
72	50	E8	58	D9	47	P22	F	M
						AN17		
						SOT0_0 (SDA0_0)		
						TIOB7_1		
73	51	C11	59	C11	48	P21	F	R
						AN18		
						SIN0_0		
						INT06_1		
						WKUP2		
74	52	C10	60	C10	-	P20	F	N
						AN19		
						INT05_0		
						CROUT_0		
						MAD24_1		
75	53	A11	-	A11	-	VSS	-	-
76	54	A10	-	-	-	VCC	-	-
77	55	A9	61	A10	49	P00	E	J
					-	TRSTX		
					-	MCSX7_1		
78	56	B9	62	B9	50	P01	E	J
						TCK		
						SWCLK		
79	57	B11	63	B11	51	P02	E	J
					-	TDI		
					-	MCSX6_1		
80	58	A8	64	A9	52	P03	E	J
						TMS		
						SWDIO		
81	59	B8	65	B8	53	P04	E	J
						TDO		
						SWO		

Pin No						Pin Name	I/O circuit type	Pin state type
LQFP-100	QFP-100	BGA-112	LQFP-80	BGA-96	LQFP-64 QFN-64			
82	60	C8	-	-	-	P05	F	Q
						AN20		
						TRACED0		
						TIOA5_2		
						SIN4_2		
						INT00_1		
MCSX5_1								
-	-	D8	-	-	-	VSS	-	-
83	61	D9	-	-	-	P06	F	Q
						AN21		
						TRACED1		
						TIOB5_2		
						SOT4_2 (SDA4_2)		
						INT01_1		
MCSX4_1								
84	62	A7	66	A8	-	P07	F	P
			-	-		AN22		
						ADTG_0		
						MCLKOUT_1		
						TRACED2		
SCK4_2 (SCL4_2)								
-	-	-	-	A7	-	VSS	-	-
85	63	B7	-	-	-	P08	F	P
						AN23		
						TRACED3		
						TIOA0_2		
						CTS4_2		
MCSX3_1								
86	64	C7	-	-	-	P09	E	O
						TRACECLK		
						TIOB0_2		
						RTS4_2		
MCSX2_1								
87	65	D7	67	C8	54	P0A	I	L
					-	SIN4_0		
						INT00_2		
						MCSX1_1		

Pin No						Pin Name	I/O circuit type	Pin state type
LQFP-100	QFP-100	BGA-112	LQFP-80	BGA-96	LQFP-64 QFN-64			
88	66	A6	68	C7	55	P0B	I	K
						SOT4_0 (SDA4_0)		
						TIOB6_1		
-	-	-	-	-	-	MCSX0_1	-	-
89	67	B6	69	B7	56	P0C	I	K
						SCK4_0 (SCL4_0)		
						TIOA6_1		
-	-	-	-	-	-	MALE_1	-	-
-	-	D4	-	-	-	VSS	-	-
-	-	C3	-	C3	-	VSS	-	-
90	68	C6	70	B6	-	P0D	E	K
						RTS4_0		
						TIOA3_2		
-	-	-	-	-	-	MDQM0_1	-	-
91	69	A5	71	C6	-	P0E	E	K
						CTS4_0		
						TIOB3_2		
-	-	-	-	-	-	MDQM1_1	-	-
-	-	-	-	A5	-	VSS	-	-
92	70	B5	72	A6	57	P0F	E	I
						NMIX		
						CROUT_1		
						RTCCO_0		
						SUBOUT_0		
-	-	-	-	-	-	WKUP0	-	-
93	71	D6	73	B5	-	P63	E	L
						INT03_0		
						MWEX_1		
94	72	C5	74	C5	58	P62	E	K
						SCK5_0 (SCL5_0)		
						ADTG_3		
-	-	-	-	-	-	MOEX_1	-	-
95	73	B4	75	B4	59	P61	E	K
						SOT5_0 (SDA5_0)		
						TIOB2_2		

Pin No						Pin Name	I/O circuit type	Pin state type
LQFP-100	QFP-100	BGA-112	LQFP-80	BGA-96	LQFP-64 QFN-64			
96	74	C4	76	C4	60	P60	I	T
						SIN5_0		
						TIOA2_2		
						INT15_1		
						WKUP3		
					CEC1			
					-	MRDY_1		
97	75	A4	77	A4	61	VCC	-	
98	76	A3	78	A3	62	P80	H	H
99	77	A2	79	A2	63	P81	H	H
100	78	A1	80	A1	64	VSS	-	

- List of pin functions

The number after the underscore ("_") in pin names such as XXX_1 and XXX_2 indicates the relocated port number. For these pins, there are multiple pins that provide the same function for the same channel. Use the extended port function register (EPFR) to select the pin.

Pin function	Pin name	Function description	Pin No					
			LQFP-100	QFP-100	BGA-112	LQFP-80	BGA-96	LQFP/QFN-64
ADC	ADTG_0	A/D converter external trigger input pin	84	62	A7	66	A8	-
	ADTG_1		7	85	D3	7	D3	-
	ADTG_2		18	96	F4	13	G3	9
	ADTG_3		94	72	C5	74	C5	58
	ADTG_4		-	-	-	-	-	-
	ADTG_5		70	48	D11	-	-	-
	ADTG_6		12	90	E4	12	G2	8
	ADTG_7		30	8	J5	-	-	-
	ADTG_8		-	-	-	-	-	-
	AN00	A/D converter analog input pin. ANxx describes ADC ch.xx.	52	30	J11	42	J11	34
	AN01		53	31	J10	43	J10	35
	AN02		54	32	J8	44	J8	36
	AN03		55	33	H10	45	H10	37
	AN04		56	34	H9	46	H9	38
	AN05		57	35	H7	47	G10	39
	AN06		58	36	G10	48	G9	-
	AN07		59	37	G9	49	F10	40
	AN08		63	41	G8	53	F9	44
	AN09		64	42	F10	54	E11	45
	AN10		65	43	F9	55	E10	-
	AN11		66	44	E11	56	E9	-
	AN12		67	45	E10	-	-	-
	AN13		68	46	F8	-	-	-
	AN14		69	47	E9	-	-	-
AN15	70		48	D11	-	-	-	
AN16	71		49	D10	57	D10	46	
AN17	72		50	E8	58	D9	47	
AN18	73		51	C11	59	C11	48	
AN19	74		52	C10	60	C10	-	
AN20	82		60	C8	-	-	-	
AN21	83		61	D9	-	-	-	
AN22	84		62	A7	66	A8	-	
AN23	85	63	B7	-	-	-		

Pin function	Pin name	Function description	Pin No					
			LQFP-100	QFP-100	BGA-112	LQFP-80	BGA-96	LQFP/QFN-64
Base Timer 0	TIOA0_0	Base timer ch.0 TIOA pin	27	5	J4	-	-	-
	TIOA0_1		19	97	G3	14	H1	10
	TIOA0_2		85	63	B7	-	-	-
	TIOB0_0	Base timer ch.0 TIOB pin	40	18	J6	30	K6	22
	TIOB0_1		9	87	E1	9	E2	5
	TIOB0_2		86	64	C7	-	-	-
Base Timer 1	TIOA1_0	Base timer ch.1 TIOA pin	28	6	L5	-	-	-
	TIOA1_1		20	98	H1	15	H2	11
	TIOA1_2		5	83	D1	5	D1	-
	TIOB1_0	Base timer ch.1 TIOB pin	41	19	L7	31	J6	23
	TIOB1_1		10	88	E2	10	E3	6
	TIOB1_2		6	84	D2	6	D2	-
Base Timer 2	TIOA2_0	Base timer ch.2 TIOA pin	29	7	K5	-	-	-
	TIOA2_1		21	99	H2	16	H3	12
	TIOA2_2		96	74	C4	76	C4	60
	TIOB2_0	Base timer ch.2 TIOB pin	42	20	K7	32	L7	24
	TIOB2_1		11	89	E3	11	G1	7
	TIOB2_2		95	73	B4	75	B4	59
Base Timer 3	TIOA3_0	Base timer ch.3 TIOA pin	30	8	J5	-	-	-
	TIOA3_1		22	100	G4	17	J1	13
	TIOA3_2		90	68	C6	70	B6	-
	TIOB3_0	Base timer ch.3 TIOB pin	43	21	H6	33	K7	25
	TIOB3_1		12	90	E4	12	G2	8
	TIOB3_2		91	69	A5	71	C6	-
Base Timer 4	TIOA4_0	Base timer ch.4 TIOA pin	31	9	H5	21	L5	-
	TIOA4_1		23	1	H3	18	J2	14
	TIOA4_2		-	-	-	-	-	-
	TIOB4_0	Base timer ch.4 TIOB pin	44	22	J7	34	J7	26
	TIOB4_1		13	91	F1	-	-	-
	TIOB4_2		-	-	-	-	-	-
Base Timer 5	TIOA5_0	Base timer ch.5 TIOA pin	32	10	L6	22	K5	-
	TIOA5_1		24	2	J2	19	J4	15
	TIOA5_2		82	60	C8	-	-	-
	TIOB5_0	Base timer ch.5 TIOB pin	45	23	K8	35	K8	27
	TIOB5_1		14	92	F2	-	-	-
	TIOB5_2		83	61	D9	-	-	-
Base Timer 6	TIOA6_1	Base timer ch.6 TIOA pin	89	67	B6	69	B7	56
	TIOB6_1	Base timer ch.6 TIOB pin	88	66	A6	68	C7	55
Base Timer 7	TIOA7_0	Base timer ch.7 TIOA pin	-	-	-	-	-	-
	TIOA7_1		71	49	D10	57	D10	46
	TIOA7_2		-	-	-	-	-	-
	TIOB7_0	Base timer ch.7 TIOB pin	-	-	-	-	-	-
	TIOB7_1		72	50	E8	58	D9	47
	TIOB7_2		-	-	-	-	-	-

Pin function	Pin name	Function description	Pin No					
			LQFP-100	QFP-100	BGA-112	LQFP-80	BGA-96	LQFP/QFN-64
Debugger	SWCLK	Serial wire debug interface clock input pin	78	56	B9	62	B9	50
	SWDIO	Serial wire debug interface data input / output pin	80	58	A8	64	A9	52
	SWO	Serial wire viewer output pin	81	59	B8	65	B8	53
	TCK	J-TAG test clock input pin	78	56	B9	62	B9	50
	TDI	J-TAG test data input pin	79	57	B11	63	B11	51
	TDO	J-TAG debug data output pin	81	59	B8	65	B8	53
	TMS	J-TAG test mode state input/output pin	80	58	A8	64	A9	52
	TRACECLK	Trace CLK output pin of ETM	86	64	C7	-	-	-
	TRACED0	Trace data output pins of ETM	82	60	C8	-	-	-
	TRACED1		83	61	D9	-	-	-
	TRACED2		84	62	A7	-	-	-
	TRACED3		85	63	B7	-	-	-
	TRSTX	J-TAG test reset input pin	77	55	A9	61	A10	49
External Bus	MAD00_1	External bus interface address bus	31	9	H5	21	L5	-
	MAD01_1		32	10	L6	22	K5	-
	MAD02_1		39	17	K6	29	J5	-
	MAD03_1		40	18	J6	30	K6	-
	MAD04_1		41	19	L7	31	J6	-
	MAD05_1		42	20	K7	32	L7	-
	MAD06_1		43	21	H6	33	K7	-
	MAD07_1		44	22	J7	34	J7	-
	MAD08_1		45	23	K8	35	K8	-
	MAD09_1		53	31	J10	43	J10	-
	MAD10_1		54	32	J8	44	J8	-
	MAD11_1		55	33	H10	45	H10	-
	MAD12_1		56	34	H9	46	H9	-
	MAD13_1		57	35	H7	47	G10	-
	MAD14_1		58	36	G10	48	G9	-
	MAD15_1		59	37	G9	49	F10	-
	MAD16_1		63	41	G8	53	F9	-
	MAD17_1		64	42	F10	54	E11	-
	MAD18_1		65	43	F9	55	E10	-
	MAD19_1		66	44	E11	56	E9	-
	MAD20_1		67	45	E10	-	-	-
	MAD21_1		68	46	F8	-	-	-
	MAD22_1		69	47	E9	-	-	-
	MAD23_1		70	48	D11	-	-	-
MAD24_1	74	52	C10	60	C10	-		

Pin function	Pin name	Function description	Pin No					
			LQFP-100	QFP-100	BGA-112	LQFP-80	BGA-96	LQFP/QFN-64
External Bus	MCSX0_1	External bus interface chip select output pin	88	66	A6	68	C7	-
	MCSX1_1		87	65	D7	67	C8	-
	MCSX2_1		86	64	C7	-	-	-
	MCSX3_1		85	63	B7	-	-	-
	MCSX4_1		83	61	D9	-	-	-
	MCSX5_1		82	60	C8	-	-	-
	MCSX6_1		79	57	B11	63	B11	-
	MCSX7_1		77	55	A9	61	A10	-
	MDQM0_1	External bus interface byte mask signal output pin	90	68	C6	70	B6	-
	MDQM1_1		91	69	A5	71	C6	-
	MOEX_1	External bus interface read enable signal for SRAM	94	72	C5	74	C5	-
	MWEX_1	External bus interface write enable signal for SRAM	93	71	D6	73	B5	-
	MADATA00_1	External bus interface data bus	2	80	C1	2	C1	-
	MADATA01_1		3	81	C2	3	C2	-
	MADATA02_1		4	82	B3	4	B3	-
	MADATA03_1		5	83	D1	5	D1	-
	MADATA04_1		6	84	D2	6	D2	-
	MADATA05_1		7	85	D3	7	D3	-
	MADATA06_1		8	86	D5	8	E1	-
	MADATA07_1		9	87	E1	9	E2	-
	MADATA08_1		10	88	E2	10	E3	-
	MADATA09_1		11	89	E3	11	G1	-
	MADATA10_1		12	90	E4	12	G2	-
	MADATA11_1		13	91	F1	-	-	-
	MADATA12_1		14	92	F2	-	-	-
	MADATA13_1		15	93	F3	-	-	-
	MADATA14_1		16	94	G1	-	-	-
	MADATA15_1		17	95	G2	-	-	-
	MALE_1	Address Latch enable signal for multiplex	89	67	B6	69	B7	-
	MRDY_1	External RDY input signal	96	74	C4	76	C4	-
MCLKOUT_1	External bus clock output pin	84	62	A7	66	A8	-	

Pin function	Pin name	Function description	Pin No					
			LQFP-100	QFP-100	BGA-112	LQFP-80	BGA-96	LQFP/QFN-64
External Interrupt	INT00_0	External interrupt request 00 input pin	2	80	C1	2	C1	2
	INT00_1		82	60	C8	-	-	-
	INT00_2		87	65	D7	67	C8	54
	INT01_0	External interrupt request 01 input pin	3	81	C2	3	C2	3
	INT01_1		83	61	D9	-	-	-
	INT02_0	External interrupt request 02 input pin	4	82	B3	4	B3	4
	INT02_1		53	31	J10	43	J10	35
	INT03_0	External interrupt request 03 input pin	93	71	D6	73	B5	-
	INT03_1		56	34	H9	46	H9	38
	INT03_2		9	87	E1	9	E2	5
	INT04_0	External interrupt request 04 input pin	12	90	E4	12	G2	8
	INT04_1		59	37	G9	49	F10	40
	INT04_2		10	88	E2	10	E3	6
	INT05_0	External interrupt request 05 input pin	74	52	C10	60	C10	-
	INT05_1		65	43	F9	55	E10	-
	INT05_2		11	89	E3	11	G1	7
	INT06_1	External interrupt request 06 input pin	73	51	C11	59	C11	48
	INT06_2		45	23	K8	35	K8	27
	INT07_2	External interrupt request 07 input pin	5	83	D1	5	D1	-
	INT08_1	External interrupt request 08 input pin	14	92	F2	-	-	-
	INT08_2		8	86	D5	8	E1	-
	INT09_1	External interrupt request 09 input pin	15	93	F3	-	-	-
	INT10_1	External interrupt request 10 input pin	16	94	G1	-	-	-
	INT11_1	External interrupt request 11 input pin	17	95	G2	-	-	-
INT12_1	External interrupt request 12 input pin	27	5	J4	-	-	-	
INT13_1	External interrupt request 13 input pin	28	6	L5	-	-	-	
INT14_1	External interrupt request 14 input pin	39	17	K6	29	J5	-	
INT15_1	External interrupt request 15 input pin	96	74	C4	76	C4	60	
NMIX	Non-Maskable Interrupt input pin	92	70	B5	72	A6	57	

Pin function	Pin name	Function description	Pin No						
			LQFP-100	QFP-100	BGA-112	LQFP-80	BGA-96	LQFP/QFN-64	
GPIO	P00	General-purpose I/O port 0	77	55	A9	61	A10	49	
	P01		78	56	B9	62	B9	50	
	P02		79	57	B11	63	B11	51	
	P03		80	58	A8	64	A9	52	
	P04		81	59	B8	65	B8	53	
	P05		82	60	C8	-	-	-	
	P06		83	61	D9	-	-	-	
	P07		84	62	A7	66	A8	-	
	P08		85	63	B7	-	-	-	
	P09		86	64	C7	-	-	-	
	P0A		87	65	D7	67	C8	54	
	P0B		88	66	A6	68	C7	55	
	P0C		89	67	B6	69	B7	56	
	P0D		90	68	C6	70	B6	-	
	P0E		91	69	A5	71	C6	-	
	P0F		92	70	B5	72	A6	57	
	P10		52	General-purpose I/O port 1	30	J11	42	J11	34
	P11		53		31	J10	43	J10	35
	P12	54	32		J8	44	J8	36	
	P13	55	33		H10	45	H10	37	
	P14	56	34		H9	46	H9	38	
	P15	57	35		H7	47	G10	39	
	P16	58	36		G10	48	G9	-	
	P17	59	37		G9	49	F10	40	
	P18	63	41		G8	53	F9	44	
	P19	64	42		F10	54	E11	45	
	P1A	65	43		F9	55	E10	-	
	P1B	66	44		E11	56	E9	-	
	P1C	67	45	E10	-	-	-		
	P1D	68	46	F8	-	-	-		
P1E	69	47	E9	-	-	-			
P1F	70	48	D11	-	-	-			
P20	74	General-purpose I/O port 2	52	C10	60	C10	-		
P21	73		51	C11	59	C11	48		
P22	72		50	E8	58	D9	47		
P23	71		49	D10	57	D10	46		

Pin function	Pin name	Function description	Pin No						
			LQFP-100	QFP-100	BGA-112	LQFP-80	BGA-96	LQFP/QFN-64	
GPIO	P30	General-purpose I/O port 3	9	87	E1	9	E2	5	
	P31		10	88	E2	10	E3	6	
	P32		11	89	E3	11	G1	7	
	P33		12	90	E4	12	G2	8	
	P34		13	91	F1	-	-	-	
	P35		14	92	F2	-	-	-	
	P36		15	93	F3	-	-	-	
	P37		16	94	G1	-	-	-	
	P38		17	95	G2	-	-	-	
	P39		18	96	F4	13	G3	9	
	P3A		19	97	G3	14	H1	10	
	P3B		20	98	H1	15	H2	11	
	P3C		21	99	H2	16	H3	12	
	P3D		22	100	G4	17	J1	13	
	P3E		23	1	H3	18	J2	14	
	P3F		24	2	J2	19	J4	15	
	P40		27	General-purpose I/O port 4	5	J4	-	-	-
	P41		28		6	L5	-	-	-
	P42		29		7	K5	-	-	-
	P43		30		8	J5	-	-	-
	P44		31		9	H5	21	L5	-
	P45		32		10	L6	22	K5	-
	P46		36		14	L3	26	L3	19
	P47		37		15	K3	27	K3	20
	P48	39	17		K6	29	J5	-	
	P49	40	18		J6	30	K6	22	
	P4A	41	19		L7	31	J6	23	
	P4B	42	20		K7	32	L7	24	
	P4C	43	21		H6	33	K7	25	
	P4D	44	22		J7	34	J7	26	
	P4E	45	23		K8	35	K8	27	
P50	2	General-purpose I/O port 5	80		C1	2	C1	2	
P51	3		81		C2	3	C2	3	
P52	4		82	B3	4	B3	4		
P53	5		83	D1	5	D1	-		
P54	6		84	D2	6	D2	-		
P55	7		85	D3	7	D3	-		
P56	8		86	D5	8	E1	-		
P60	96		74	C4	76	C4	60		
P61	95	73	B4	75	B4	59			
P62	94	72	C5	74	C5	58			
P63	93	71	D6	73	B5	-			
P80	98	76	A3	78	A3	62			
P81	99	77	A2	79	A2	63			
PE0	46	24	K9	36	K9	28			
PE2	48	26	L9	38	L9	30			
PE3	49	27	L10	39	L10	31			

Pin function	Pin name	Function description	Pin No					
			LQFP-100	QFP-100	BGA-112	LQFP-80	BGA-96	LQFP/QFN-64
Multi-function Serial 0	SIN0_0	Multi-function serial interface ch.0 input pin	73	51	C11	59	C11	48
	SIN0_1		56	34	H9	46	H9	-
	SOT0_0 (SDA0_0)	Multi-function serial interface ch.0 output pin. This pin operates as SOT0 when it is used in a UART/CSIO (operation modes 0 to 2) and as SDA0 when it is used in an I ² C (operation mode 4).	72	50	E8	58	D9	47
	SOT0_1 (SDA0_1)		57	35	H7	47	G10	-
	SCK0_0 (SCL0_0)	Multi-function serial interface ch.0 clock I/O pin. This pin operates as SCK0 when it is used in a UART/CSIO (operation modes 0 to 2) and as SCL0 when it is used in an I ² C (operation mode 4).	71	49	D10	57	D10	46
	SCK0_1 (SCL0_1)		58	36	G10	48	G9	-
Multi-function Serial 1	SIN1_1	Multi-function serial interface ch.1 input pin	53	31	J10	43	J10	35
	SOT1_1 (SDA1_1)	Multi-function serial interface ch.1 output pin. This pin operates as SOT1 when it is used in a UART/CSIO (operation modes 0 to 2) and as SDA1 when it is used in an I ² C (operation mode 4).	54	32	J8	44	J8	36
	SCK1_1 (SCL1_1)	Multi-function serial interface ch.1 clock I/O pin. This pin operates as SCK1 when it is used in a UART/CSIO (operation modes 0 to 2) and as SCL1 when it is used in an I ² C (operation mode 4).	55	33	H10	45	H10	37

Pin function	Pin name	Function description	Pin No					
			LQFP-100	QFP-100	BGA-112	LQFP-80	BGA-96	LQFP/QFN-64
Multi-function Serial 2	SIN2_2	Multi-function serial interface ch.2 input pin	59	37	G9	49	F10	40
	SOT2_2 (SDA2_2)	Multi-function serial interface ch.2 output pin. This pin operates as SOT2 when it is used in a UART/CSIO (operation modes 0 to 2) and as SDA2 when it is used in an I ² C (operation mode 4).	63	41	G8	53	F9	44
	SCK2_2 (SCL2_2)	Multi-function serial interface ch.2 clock I/O pin. This pin operates as SCK2 when it is used in a UART/CSIO (operation modes 0 to 2) and as SCL2 when it is used in an I ² C (operation mode 4).	64	42	F10	54	E11	45
Multi-function Serial 3	SIN3_1	Multi-function serial interface ch.3 input pin	2	80	C1	2	C1	2
	SIN3_2		39	17	K6	29	J5	-
	SOT3_1 (SDA3_1)	Multi-function serial interface ch.3 output pin. This pin operates as SOT3 when it is used in a UART/CSIO (operation modes 0 to 2) and as SDA3 when it is used in an I ² C (operation mode 4).	3	81	C2	3	C2	3
	SOT3_2 (SDA3_2)	Multi-function serial interface ch.3 output pin. This pin operates as SOT3 when it is used in a UART/CSIO (operation modes 0 to 2) and as SDA3 when it is used in an I ² C (operation mode 4).	40	18	J6	30	K6	-
	SCK3_1 (SCL3_1)	Multi-function serial interface ch.3 clock I/O pin. This pin operates as SCK3 when it is used in a UART/CSIO (operation modes 0 to 2) and as SCL3 when it is used in an I ² C (operation mode 4).	4	82	B3	4	B3	4
	SCK3_2 (SCL3_2)	Multi-function serial interface ch.3 clock I/O pin. This pin operates as SCK3 when it is used in a UART/CSIO (operation modes 0 to 2) and as SCL3 when it is used in an I ² C (operation mode 4).	41	19	L7	31	J6	-

Pin function	Pin name	Function description	Pin No					
			LQFP-100	QFP-100	BGA-112	LQFP-80	BGA-96	LQFP/QFN-64
Multi-function Serial 4	SIN4_0	Multi-function serial interface ch.4 input pin	87	65	D7	67	C8	54
	SIN4_1		65	43	F9	55	E10	-
	SIN4_2		82	60	C8	-	-	-
	SOT4_0 (SDA4_0)	Multi-function serial interface ch.4 output pin. This pin operates as SOT4 when it is used in a UART/CSIO (operation modes 0 to 2) and as SDA4 when it is used in an I ² C (operation mode 4).	88	66	A6	68	C7	55
	SOT4_1 (SDA4_1)		66	44	E11	56	E9	-
	SOT4_2 (SDA4_2)		83	61	D9	-	-	-
	SCK4_0 (SCL4_0)	Multi-function serial interface ch.4 clock I/O pin. This pin operates as SCK4 when it is used in a UART/CSIO (operation modes 0 to 2) and as SCL4 when it is used in an I ² C (operation mode 4).	89	67	B6	69	B7	56
	SCK4_1 (SCL4_1)		67	45	E10	-	-	-
	SCK4_2 (SCL4_2)		84	62	A7	-	-	-
	RTS4_0	Multi-function serial interface ch.4 RTS output pin	90	68	C6	70	B6	-
	RTS4_1		69	47	E9	-	-	-
	RTS4_2		86	64	C7	-	-	-
	CTS4_0	Multi-function serial interface ch.4 CTS input pin	91	69	A5	71	C6	-
	CTS4_1		68	46	F8	-	-	-
	CTS4_2		85	63	B7	-	-	-
Multi-function Serial 5	SIN5_0	Multi-function serial interface ch.5 input pin	96	74	C4	76	C4	60
	SIN5_2		15	93	F3	-	-	-
	SOT5_0 (SDA5_0)	Multi-function serial interface ch.5 output pin. This pin operates as SOT5 when it is used in a UART/CSIO (operation modes 0 to 2) and as SDA5 when it is used in an I ² C (operation mode 4).	95	73	B4	75	B4	59
	SOT5_2 (SDA5_2)		16	94	G1	-	-	-
	SCK5_0 (SCL5_0)	Multi-function serial interface ch.5 clock I/O pin. This pin operates as SCK5 when it is used in a UART/CSIO (operation modes 0 to 2) and as SCL5 when it is used in an I ² C (operation mode 4).	94	72	C5	74	C5	58
	SCK5_2 (SCL5_2)		17	95	G2	-	-	-

Pin function	Pin name	Function description	Pin No					
			LQFP-100	QFP-100	BGA-112	LQFP-80	BGA-96	LQFP/QFN-64
Multi-function Serial 6	SIN6_0	Multi-function serial interface ch.6 input pin	5	83	D1	5	D1	-
	SIN6_1		12	90	E4	12	G2	8
	SOT6_0 (SDA6_0)	Multi-function serial interface ch.6 output pin. This pin operates as SOT6 when it is used in a UART/CSIO (operation modes 0 to 2) and as SDA6 when it is used in an I ² C (operation mode 4).	6	84	D2	6	D2	-
	SOT6_1 (SDA6_1)		11	89	E3	11	G1	7
	SCK6_0 (SCL6_0)	Multi-function serial interface ch.6 clock I/O pin. This pin operates as SCK6 when it is used in a UART/CSIO (operation modes 0 to 2) and as SCL6 when it is used in an I ² C (operation mode 4).	7	85	D3	7	D3	-
	SCK6_1 (SCL6_1)		10	88	E2	10	E3	6
Multi-function Serial 7	SIN7_1	Multi-function serial interface ch.7 input pin	45	23	K8	35	K8	27
	SOT7_1 (SDA7_1)	Multi-function serial interface ch.7 output pin. This pin operates as SOT7 when it is used in a UART/CSIO (operation modes 0 to 2) and as SDA7 when it is used in an I ² C (operation mode 4).	44	22	J7	34	J7	26
	SCK7_1 (SCL7_1)	Multi-function serial interface ch.7 clock I/O pin. This pin operates as SCK7 when it is used in a UART/CSIO (operation modes 0 to 2) and as SCL7 when it is used in an I ² C (operation mode 4).	43	21	H6	33	K7	25

Pin function	Pin name	Function description	Pin No					
			LQFP-100	QFP-100	BGA-112	LQFP-80	BGA-96	LQFP/QFN-64
Real-time clock	RTCCO_0	0.5 seconds pulse output pin of Real-time clock	92	70	B5	72	A6	57
	RTCCO_1		55	33	H10	45	H10	37
	RTCCO_2		19	97	G3	14	H1	10
	SUBOUT_0	Sub clock output pin	92	70	B5	72	A6	57
	SUBOUT_1		55	33	H10	45	H10	37
	SUBOUT_2		19	97	G3	14	H1	10
Low-Power Consumption Mode	WKUP0	Deep standby mode return signal input pin 0	92	70	B5	72	A6	57
	WKUP1	Deep standby mode return signal input pin 1	53	31	J10	43	J10	35
	WKUP2	Deep standby mode return signal input pin 2	73	51	C11	59	C11	48
	WKUP3	Deep standby mode return signal input pin 3	96	74	C4	76	C4	60
HDMI-CEC/Remote Control	CEC0	HDMI-CEC/RemoteControl Reception ch.0 input/output pin	43	21	H6	33	K7	25
	CEC1	HDMI-CEC/RemoteControl Reception ch.1 input/output pin	96	74	C4	76	C4	60

Pin function	Pin name	Function description	Pin No					
			LQFP-100	QFP-100	BGA-112	LQFP-80	BGA-96	LQFP/QFN-64
RESET	INITX	External Reset Input pin. A reset is valid when INITX="L".	38	16	K4	28	K4	21
Mode	MD0	Mode 0 pin. During normal operation, MD0="L" must be input. During serial programming to Flash memory, MD0="H" must be input.	47	25	L8	37	L8	29
	MD1	Mode 1 pin. During serial programming to Flash memory, MD1="L" must be input.	46	24	K9	36	K9	28
POWER	VCC	Power supply Pin	1	79	B1	1	B1	1
	VCC	Power supply Pin	26	4	J1	-	-	-
	VCC	Power supply Pin	35	13	K1	25	K1	18
	VCC	Power supply Pin	51	29	K11	41	K11	33
	VCC	Power supply Pin	76	54	A10	-	-	-
	VCC	Power supply Pin	97	75	A4	77	A4	61
GND	VSS	GND Pin	-	-	-	-	F1	-
	VSS	GND Pin	-	-	-	-	F2	-
	VSS	GND Pin	-	-	-	-	F3	-
	VSS	GND Pin	-	-	B2	-	B2	-
	VSS	GND Pin	25	3	L1	20	L1	16
	VSS	GND Pin	-	-	K2	-	K2	-
	VSS	GND Pin	-	-	J3	-	J3	-
	VSS	GND Pin	-	-	H4	-	-	-
	VSS	GND Pin	-	-	-	-	L6	-
	VSS	GND Pin	34	12	L4	24	L4	-
	VSS	GND Pin	50	28	L11	40	L11	32
	VSS	GND Pin	-	-	K10	-	K10	-
	VSS	GND Pin	-	-	J9	-	J9	-
	VSS	GND Pin	-	-	H8	-	-	-
	VSS	GND Pin	-	-	B10	-	B10	-
	VSS	GND Pin	-	-	C9	-	C9	-
	VSS	GND Pin	-	-	-	-	D11	-
	VSS	GND Pin	75	53	A11	-	A11	-
	VSS	GND Pin	-	-	D8	-	-	-
	VSS	GND Pin	-	-	-	-	A7	-
	VSS	GND Pin	-	-	D4	-	-	-
	VSS	GND Pin	-	-	C3	-	C3	-
	VSS	GND Pin	-	-	-	-	A5	-
VSS	GND Pin	100	78	A1	80	A1	64	

Pin function	Pin name	Function description	Pin No					
			LQFP-100	QFP-100	BGA-112	LQFP-80	BGA-96	LQFP/QFN-64
CLOCK	X0	Main clock (oscillation) input pin	48	26	L9	38	L9	30
	X0A	Sub clock (oscillation) input pin	36	14	L3	26	L3	19
	X1	Main clock (oscillation) I/O pin	49	27	L10	39	L10	31
	X1A	Sub clock (oscillation) I/O pin	37	15	K3	27	K3	20
	CROUT_0	Built-in high-speed CR-osc clock output port	74	52	C10	60	C10	-
	CROUT_1		92	70	B5	72	A6	57
ADC POWER	AVCC	A/D converter analog power supply pin	60	38	H11	50	H11	41
	AVRH	A/D converter analog reference voltage input pin	61	39	F11	51	F11	42
ADC GND	AVSS	A/D converter GND pin	62	40	G11	52	G11	43
C pin	C	Power stabilization capacity pin	33	11	L2	23	L2	17

■ I/O CIRCUIT TYPE

Type	Circuit	Remarks
A	<p>The diagram for Type A shows two oscillators, X1 and X0. Each oscillator has a pull-up resistor R connected to its output. The X1 oscillator output is connected to a P-channel MOSFET (P-ch) and an N-channel MOSFET (N-ch), both labeled as Digital output. The X0 oscillator output is also connected to a P-channel MOSFET (P-ch) and an N-channel MOSFET (N-ch), both labeled as Digital output. The X1 oscillator output is also connected to a Digital input, a Standby mode control, and a Clock input. The X0 oscillator output is connected to a Digital input and a Standby mode control. The circuit includes various logic gates and control signals.</p>	<p>It is possible to select the main oscillation / GPIO function</p> <p>When the main oscillation is selected.</p> <ul style="list-style-type: none"> • Oscillation feedback resistor : Approximately 1MΩ • With Standby mode control <p>When the GPIO is selected.</p> <ul style="list-style-type: none"> • CMOS level output. • CMOS level hysteresis input • With pull-up resistor control • With standby mode control • Pull-up resistor : Approximately 33kΩ • $I_{OH} = -4mA, I_{OL} = 4mA$
B	<p>The diagram for Type B shows a pull-up resistor connected to a digital input through a resistor and a hysteresis input.</p>	<ul style="list-style-type: none"> • CMOS level hysteresis input • Pull-up resistor : Approximately 33kΩ

Type	Circuit	Remarks
C		<ul style="list-style-type: none"> • Open drain output • CMOS level hysteresis input
D		<p>It is possible to select the sub oscillation / GPIO function</p> <p>When the sub oscillation is selected.</p> <ul style="list-style-type: none"> • Oscillation feedback resistor : Approximately 5MΩ • With Standby mode control <p>When the GPIO is selected.</p> <ul style="list-style-type: none"> • CMOS level output. • CMOS level hysteresis input • With pull-up resistor control • With standby mode control • Pull-up resistor : Approximately 33kΩ • I_{OH}= -4mA, I_{OL}= 4mA

Type	Circuit	Remarks
E		<ul style="list-style-type: none"> • CMOS level output • CMOS level hysteresis input • With pull-up resistor control • With standby mode control • Pull-up resistor : Approximately 33kΩ • $I_{OH} = -4mA$, $I_{OL} = 4mA$ • When this pin is used as an I²C pin, the digital output P-ch transistor is always off
F		<ul style="list-style-type: none"> • CMOS level output • CMOS level hysteresis input • With input control • Analog input • With pull-up resistor control • With standby mode control • Pull-up resistor : Approximately 33kΩ • $I_{OH} = -4mA$, $I_{OL} = 4mA$ • When this pin is used as an I²C pin, the digital output P-ch transistor is always off
G		<p>CMOS level hysteresis input</p>

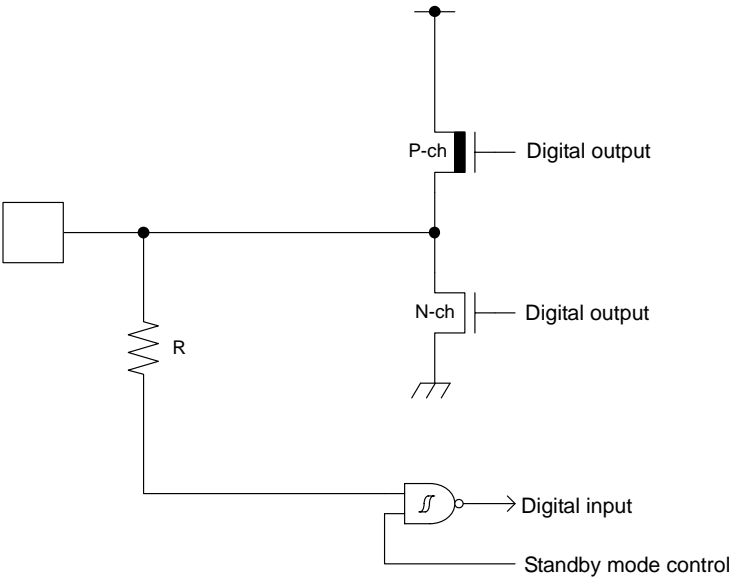
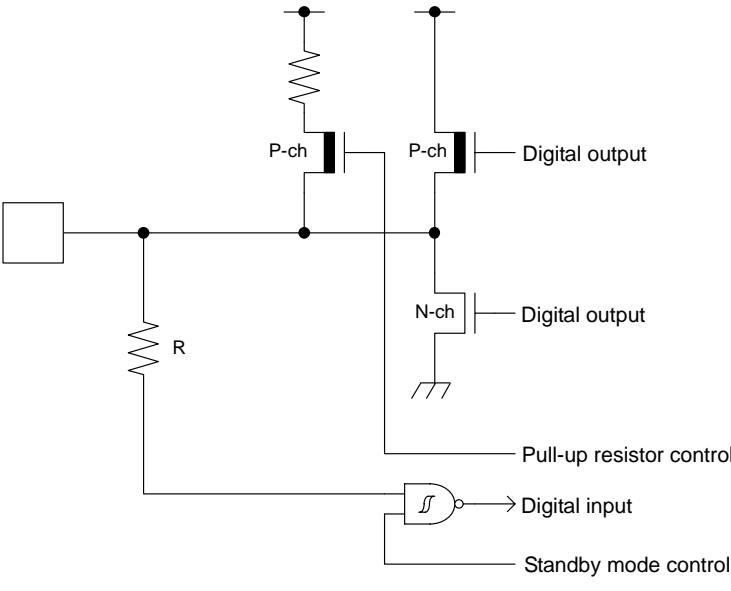
Type	Circuit	Remarks
H		<ul style="list-style-type: none"> • CMOS level output • CMOS level hysteresis input • With standby mode control $I_{OH} = -12.0\text{mA}$, $I_{OL} = 10.5\text{mA}$
I		<ul style="list-style-type: none"> • CMOS level output • CMOS level hysteresis input • 5V tolerant • With pull-up resistor control • With standby mode control • Pull-up resistor : Approximately $33\text{k}\Omega$ • $I_{OH} = -4\text{mA}$, $I_{OL} = 4\text{mA}$ • Available to control PZR registers. • When this pin is used as an I²C pin, the digital output P-ch transistor is always off

■ HANDLING PRECAUTIONS

Any semiconductor devices have inherently a certain rate of failure. The possibility of failure is greatly affected by the conditions in which they are used (circuit conditions, environmental conditions, etc.). This page describes precautions that must be observed to minimize the chance of failure and to obtain higher reliability from your Spansion semiconductor devices.

1. Precautions for Product Design

This section describes precautions when designing electronic equipment using semiconductor devices.

- **Absolute Maximum Ratings**

Semiconductor devices can be permanently damaged by application of stress (voltage, current, temperature, etc.) in excess of certain established limits, called absolute maximum ratings. Do not exceed these ratings.

- **Recommended Operating Conditions**

Recommended operating conditions are normal operating ranges for the semiconductor device. All the device's electrical characteristics are warranted when operated within these ranges.

Always use semiconductor devices within the recommended operating conditions. Operation outside these ranges may adversely affect reliability and could result in device failure.

No warranty is made with respect to uses, operating conditions, or combinations not represented on the data sheet. Users considering application outside the listed conditions are advised to contact their sales representative beforehand.

- **Processing and Protection of Pins**

These precautions must be followed when handling the pins which connect semiconductor devices to power supply and input/output functions.

- (1) **Preventing Over-Voltage and Over-Current Conditions**

Exposure to voltage or current levels in excess of maximum ratings at any pin is likely to cause deterioration within the device, and in extreme cases leads to permanent damage of the device. Try to prevent such overvoltage or over-current conditions at the design stage.

- (2) **Protection of Output Pins**

Shorting of output pins to supply pins or other output pins, or connection to large capacitance can cause large current flows. Such conditions if present for extended periods of time can damage the device.

Therefore, avoid this type of connection.

- (3) **Handling of Unused Input Pins**

Unconnected input pins with very high impedance levels can adversely affect stability of operation.

Such pins should be connected through an appropriate resistance to a power supply pin or ground pin.

- **Latch-up**

Semiconductor devices are constructed by the formation of P-type and N-type areas on a substrate. When subjected to abnormally high voltages, internal parasitic PNP junctions (called thyristor structures) may be formed, causing large current levels in excess of several hundred mA to flow continuously at the power supply pin. This condition is called latch-up.

CAUTION: The occurrence of latch-up not only causes loss of reliability in the semiconductor device, but can cause injury or damage from high heat, smoke or flame. To prevent this from happening, do the following:

- (1) Be sure that voltages applied to pins do not exceed the absolute maximum ratings. This should include attention to abnormal noise, surge levels, etc.

- (2) Be sure that abnormal current flows do not occur during the power-on sequence.

Code: DS00-00004-2Ea

- **Observance of Safety Regulations and Standards**

Most countries in the world have established standards and regulations regarding safety, protection from electromagnetic interference, etc. Customers are requested to observe applicable regulations and standards in the design of products.

- **Fail-Safe Design**

Any semiconductor devices have inherently a certain rate of failure. You must protect against injury, damage or loss from such failures by incorporating safety design measures into your facility and equipment such as redundancy, fire protection, and prevention of over-current levels and other abnormal operating conditions.

- **Precautions Related to Usage of Devices**

Spansion semiconductor devices are intended for use in standard applications (computers, office automation and other office equipment, industrial, communications, and measurement equipment, personal or household devices, etc.).

CAUTION: Customers considering the use of our products in special applications where failure or abnormal operation may directly affect human lives or cause physical injury or property damage, or where extremely high levels of reliability are demanded (such as aerospace systems, atomic energy controls, sea floor repeaters, vehicle operating controls, medical devices for life support, etc.) are requested to consult with sales representatives before such use. The company will not be responsible for damages arising from such use without prior approval.

2. Precautions for Package Mounting

Package mounting may be either lead insertion type or surface mount type. In either case, for heat resistance during soldering, you should only mount under Spansion's recommended conditions. For detailed information about mount conditions, contact your sales representative.

- **Lead Insertion Type**

Mounting of lead insertion type packages onto printed circuit boards may be done by two methods: direct soldering on the board, or mounting by using a socket.

Direct mounting onto boards normally involves processes for inserting leads into through-holes on the board and using the flow soldering (wave soldering) method of applying liquid solder. In this case, the soldering process usually causes leads to be subjected to thermal stress in excess of the absolute ratings for storage temperature. Mounting processes should conform to Spansion recommended mounting conditions.

If socket mounting is used, differences in surface treatment of the socket contacts and IC lead surfaces can lead to contact deterioration after long periods. For this reason it is recommended that the surface treatment of socket contacts and IC leads be verified before mounting.

- **Surface Mount Type**

Surface mount packaging has longer and thinner leads than lead-insertion packaging, and therefore leads are more easily deformed or bent. The use of packages with higher pin counts and narrower pin pitch results in increased susceptibility to open connections caused by deformed pins, or shorting due to solder bridges.

You must use appropriate mounting techniques. Spansion Inc. recommends the solder reflow method, and has established a ranking of mounting conditions for each product. Users are advised to mount packages in accordance with Spansion ranking of recommended conditions.

- **Lead-Free Packaging**

CAUTION: When ball grid array (BGA) packages with Sn-Ag-Cu balls are mounted using Sn-Pb eutectic soldering, junction strength may be reduced under some conditions of use.

- **Storage of Semiconductor Devices**

Because plastic chip packages are formed from plastic resins, exposure to natural environmental conditions will cause absorption of moisture. During mounting, the application of heat to a package that has absorbed moisture can cause surfaces to peel, reducing moisture resistance and causing packages to crack. To prevent, do the following:

- (1) Avoid exposure to rapid temperature changes, which cause moisture to condense inside the product. Store products in locations where temperature changes are slight.
- (2) Use dry boxes for product storage. Products should be stored below 70% relative humidity, and at temperatures between 5°C and 30°C.
When you open Dry Package that recommends humidity 40% to 70% relative humidity.
- (3) When necessary, Spansion Inc. packages semiconductor devices in highly moisture-resistant aluminum laminate bags, with a silica gel desiccant. Devices should be sealed in their aluminum laminate bags for storage.
- (4) Avoid storing packages where they are exposed to corrosive gases or high levels of dust.

- **Baking**

Packages that have absorbed moisture may be de-moisturized by baking (heat drying). Follow the Spansion recommended conditions for baking.

Condition: 125°C/24 h

- **Static Electricity**

Because semiconductor devices are particularly susceptible to damage by static electricity, you must take the following precautions:

- (1) Maintain relative humidity in the working environment between 40% and 70%. Use of an apparatus for ion generation may be needed to remove electricity.
- (2) Electrically ground all conveyors, solder vessels, soldering irons and peripheral equipment.
- (3) Eliminate static body electricity by the use of rings or bracelets connected to ground through high resistance (on the level of 1 MΩ).
Wearing of conductive clothing and shoes, use of conductive floor mats and other measures to minimize shock loads is recommended.
- (4) Ground all fixtures and instruments, or protect with anti-static measures.
- (5) Avoid the use of styrofoam or other highly static-prone materials for storage of completed board assemblies.

3. Precautions for Use Environment

Reliability of semiconductor devices depends on ambient temperature and other conditions as described above.

For reliable performance, do the following:

(1) Humidity

Prolonged use in high humidity can lead to leakage in devices as well as printed circuit boards. If high humidity levels are anticipated, consider anti-humidity processing.

(2) Discharge of Static Electricity

When high-voltage charges exist close to semiconductor devices, discharges can cause abnormal operation. In such cases, use anti-static measures or processing to prevent discharges.

(3) Corrosive Gases, Dust, or Oil

Exposure to corrosive gases or contact with dust or oil may lead to chemical reactions that will adversely affect the device. If you use devices in such conditions, consider ways to prevent such exposure or to protect the devices.

(4) Radiation, Including Cosmic Radiation

Most devices are not designed for environments involving exposure to radiation or cosmic radiation. Users should provide shielding as appropriate.

(5) Smoke, Flame

CAUTION: Plastic molded devices are flammable, and therefore should not be used near combustible substances. If devices begin to smoke or burn, there is danger of the release of toxic gases.

Customers considering the use of Spansion products in other special environmental conditions should consult with sales representatives.

Please check the latest handling precautions at the following URL.
<http://www.spansion.com/fjdocuments/fj/datasheet/e-ds/DS00-00004.pdf>

■ HANDLING DEVICES

● Power supply pins

In products with multiple VCC and VSS pins, respective pins at the same potential are interconnected within the device in order to prevent malfunctions such as latch-up. However, all of these pins should be connected externally to the power supply or ground lines in order to reduce electromagnetic emission levels, to prevent abnormal operation of strobe signals caused by the rise in the ground level, and to conform to the total output current rating.

Moreover, connect the current supply source with each Power supply pin and GND pin of this device at low impedance. It is also advisable that a ceramic capacitor of approximately 0.1 μF be connected as a bypass capacitor between each Power supply pin and GND pin near this device.

● Stabilizing supply voltage

A malfunction may occur when the power supply voltage fluctuates rapidly even though the fluctuation is within the recommended operating conditions of the VCC power supply voltage. As a rule, with voltage stabilization, suppress the voltage fluctuation so that the fluctuation in VCC ripple (peak-to-peak value) at the commercial frequency (50 Hz/60 Hz) does not exceed 10% of the VCC value in the recommended operating conditions, and the transient fluctuation rate does not exceed 0.1 V/ μs when there is a momentary fluctuation on switching the power supply..

● Crystal oscillator circuit

Noise near the X0/X1 and X0A/X1A pins may cause the device to malfunction. Design the printed circuit board so that X0/X1, X0A/X1A pins, the crystal oscillator, and the bypass capacitor to ground are located as close to the device as possible.

It is strongly recommended that the PC board artwork be designed such that the X0/X1 and X0A/X1A pins are surrounded by ground plane as this is expected to produce stable operation.

Evaluate oscillation of your using crystal oscillator by your mount board.

● Sub crystal oscillator

This series sub oscillator circuit is low gain to keep the low current consumption. The crystal oscillator to fill the following conditions is recommended for sub crystal oscillator to stabilize the oscillation.

- Surface mount type
 - Size : More than 3.2mm \times 1.5mm
 - Load capacitance : Approximately 6pF to 7pF
- Lead type
 - Load capacitance : Approximately 6pF to 7pF

● Using an external clock

When using an external clock as an input of the main clock, set X0/X1 to the external clock input, and input the clock to X0. X1(PE3) can be used as a general-purpose I/O port.

Similarly, when using an external clock as an input of the sub clock, set X0A/X1A to the external clock input, and input the clock to X0A. X1A (P47) can be used as a general-purpose I/O port.

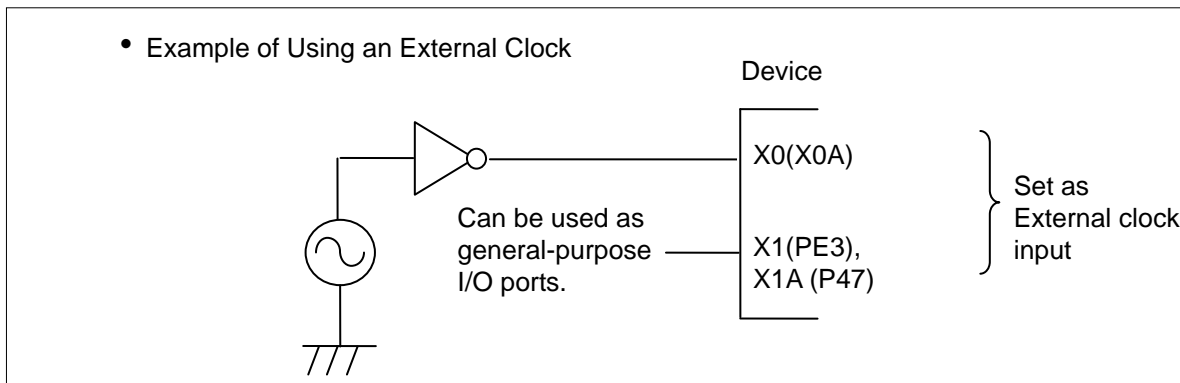

● Handling when using Multi-function serial pin as I²C pin

If it is using the multi-function serial pin as I²C pins, P-ch transistor of digital output is always disabled.

However, I²C pins need to keep the electrical characteristic like other pins and not to connect to the external I²C bus system with power OFF.

● C Pin

This series contains the regulator. Be sure to connect a smoothing capacitor (C_s) for the regulator between the C pin and the GND pin. Please use a ceramic capacitor or a capacitor of equivalent frequency characteristics as a smoothing capacitor.

However, some laminated ceramic capacitors have the characteristics of capacitance variation due to thermal fluctuation (F characteristics and Y5V characteristics). Please select the capacitor that meets the specifications in the operating conditions to use by evaluating the temperature characteristics of a capacitor. A smoothing capacitor of about 4.7μF would be recommended for this series.

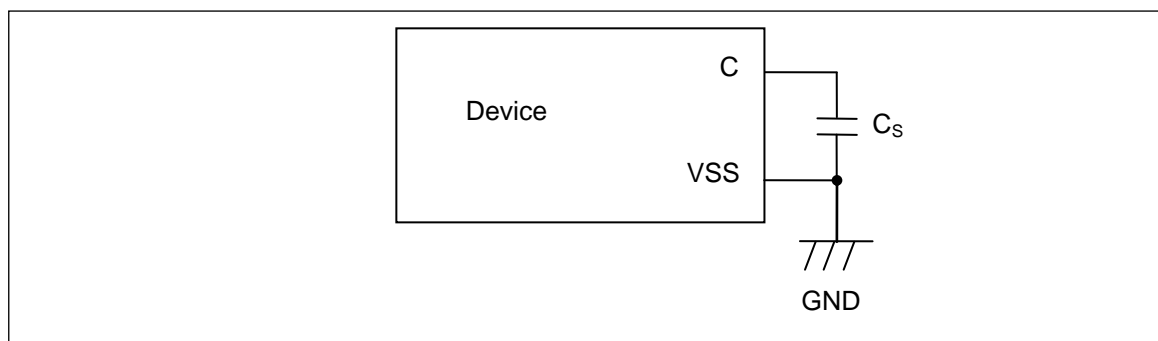

● Mode pins (MD0)

Connect the MD pin (MD0) directly to VCC or VSS pins. Design the printed circuit board such that the pull-up/down resistor stays low, as well as the distance between the mode pins and VCC pins or VSS pins is as short as possible and the connection impedance is low, when the pins are pulled-up/down such as for switching the pin level and rewriting the Flash memory data. It is because of preventing the device erroneously switching to test mode due to noise.

- Notes on power-on

Turn power on/off in the following order or at the same time.

If not using the A/D converter, connect AVCC = VCC and AVSS = VSS.

Turning on : VCC → AVCC → AVRH

Turning off : AVRH → AVCC → VCC

- Serial Communication

There is a possibility to receive wrong data due to the noise or other causes on the serial communication.

Therefore, design a printed circuit board so as to avoid noise.

Consider the case of receiving wrong data due to noise, perform error detection such as by applying a checksum of data at the end. If an error is detected, retransmit the data.

- Differences in features among the products with different memory sizes and between Flash memory products and MASK products

The electric characteristics including power consumption, ESD, latch-up, noise characteristics, and oscillation characteristics among the products with different memory sizes and between Flash memory products and MASK products are different because chip layout and memory structures are different.

If you are switching to use a different product of the same series, please make sure to evaluate the electric characteristics.

- Pull-Up function of 5V tolerant I/O

Please do not input the signal more than VCC voltage at the time of Pull-Up function use of 5V tolerant I/O.

■ BLOCK DIAGRAM

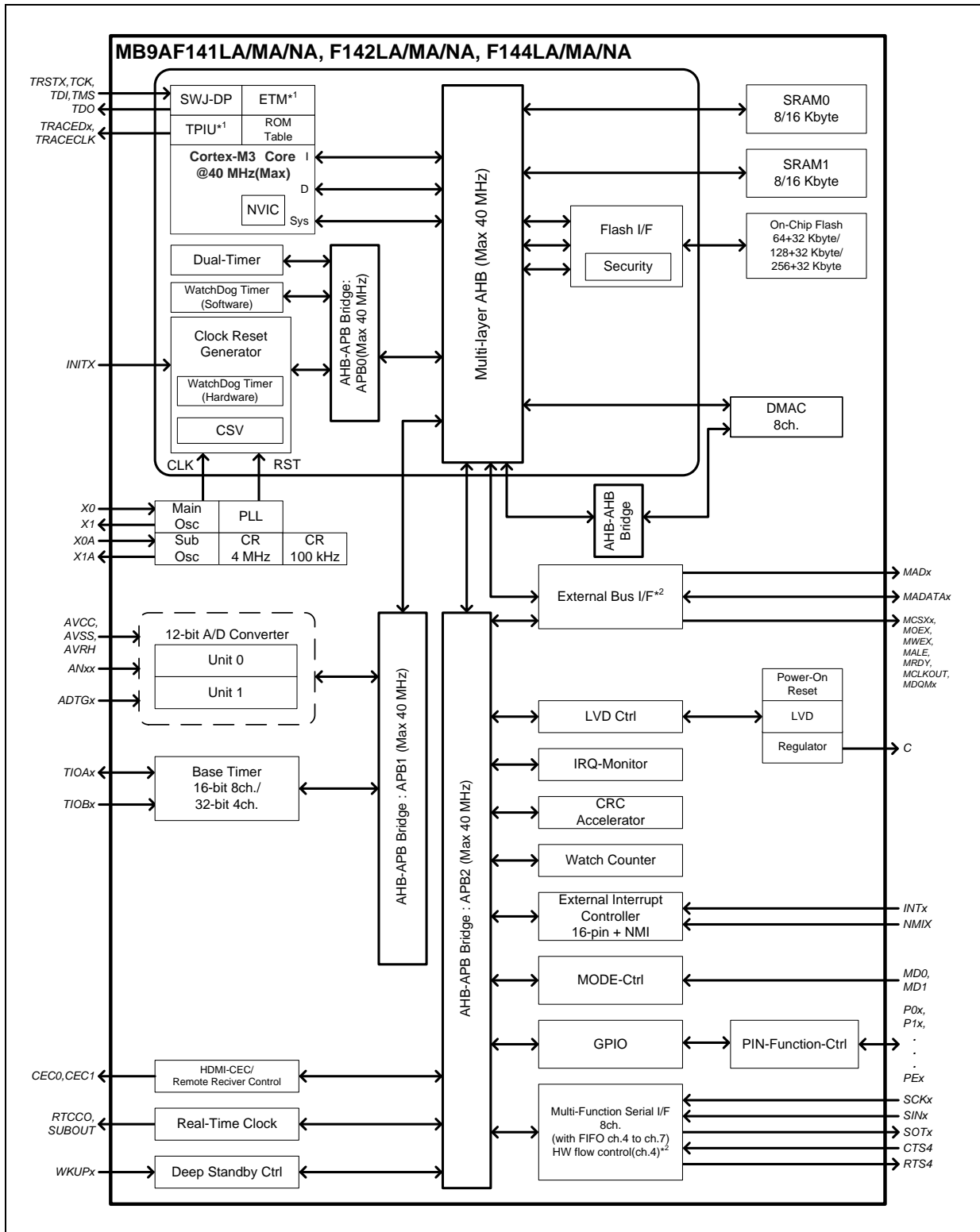

*1: For the MB9AF141LA/MA, MB9AF142LA/MA, and MB9AF144LA/MA, ETM is not available.

*2: For the MB9AF141LA, MB9AF142LA and MB9AF144LA, the External Bus Interface is not available. And the Multi-function Serial Interface does not support hardware flow control in these products.

■ MEMORY SIZE

See " • Memory size" in "■PRODUCT LINEUP" to confirm the memory size.

■ MEMORY MAP

● Memory Map (1)

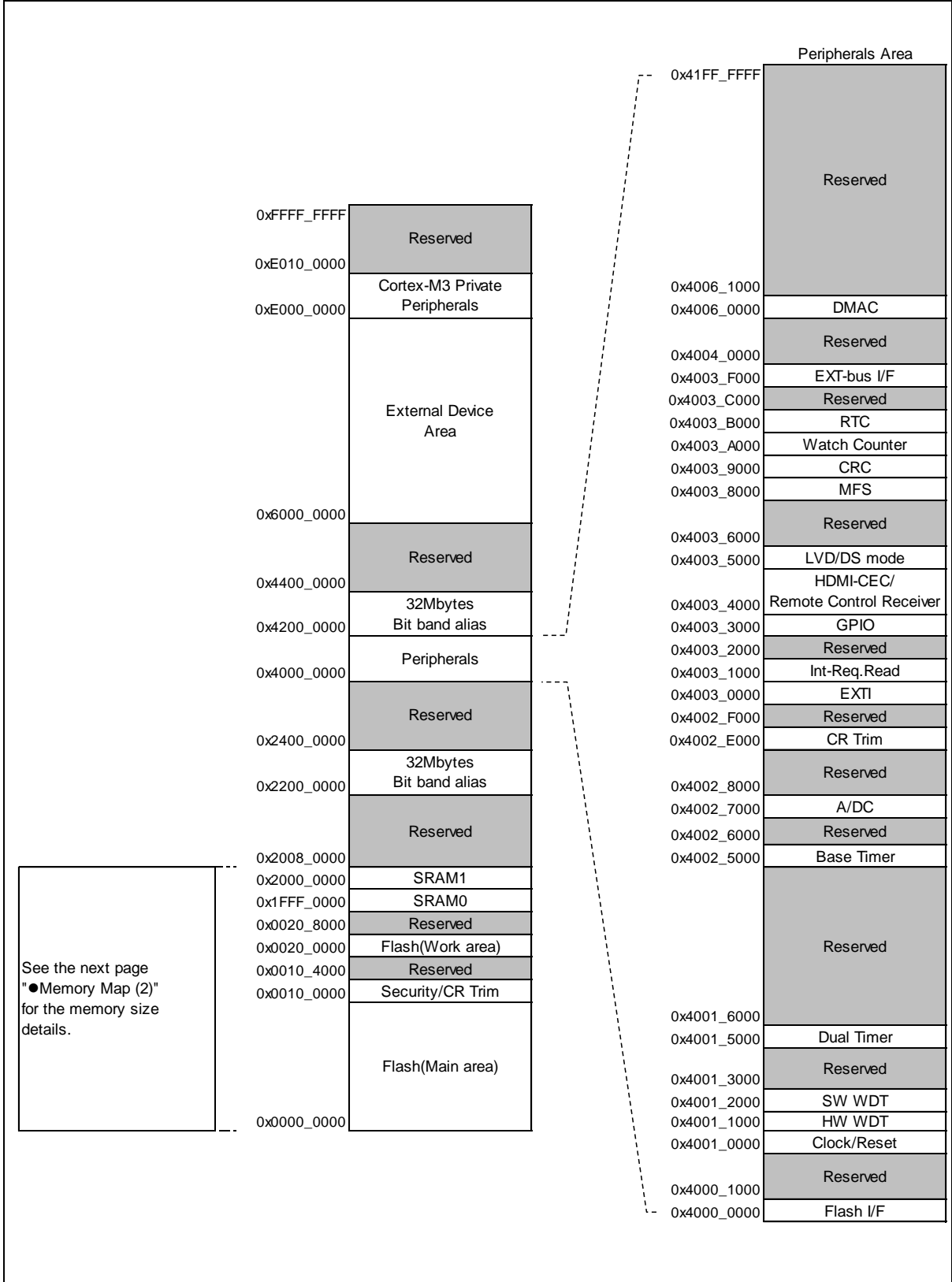

● Memory Map (2)

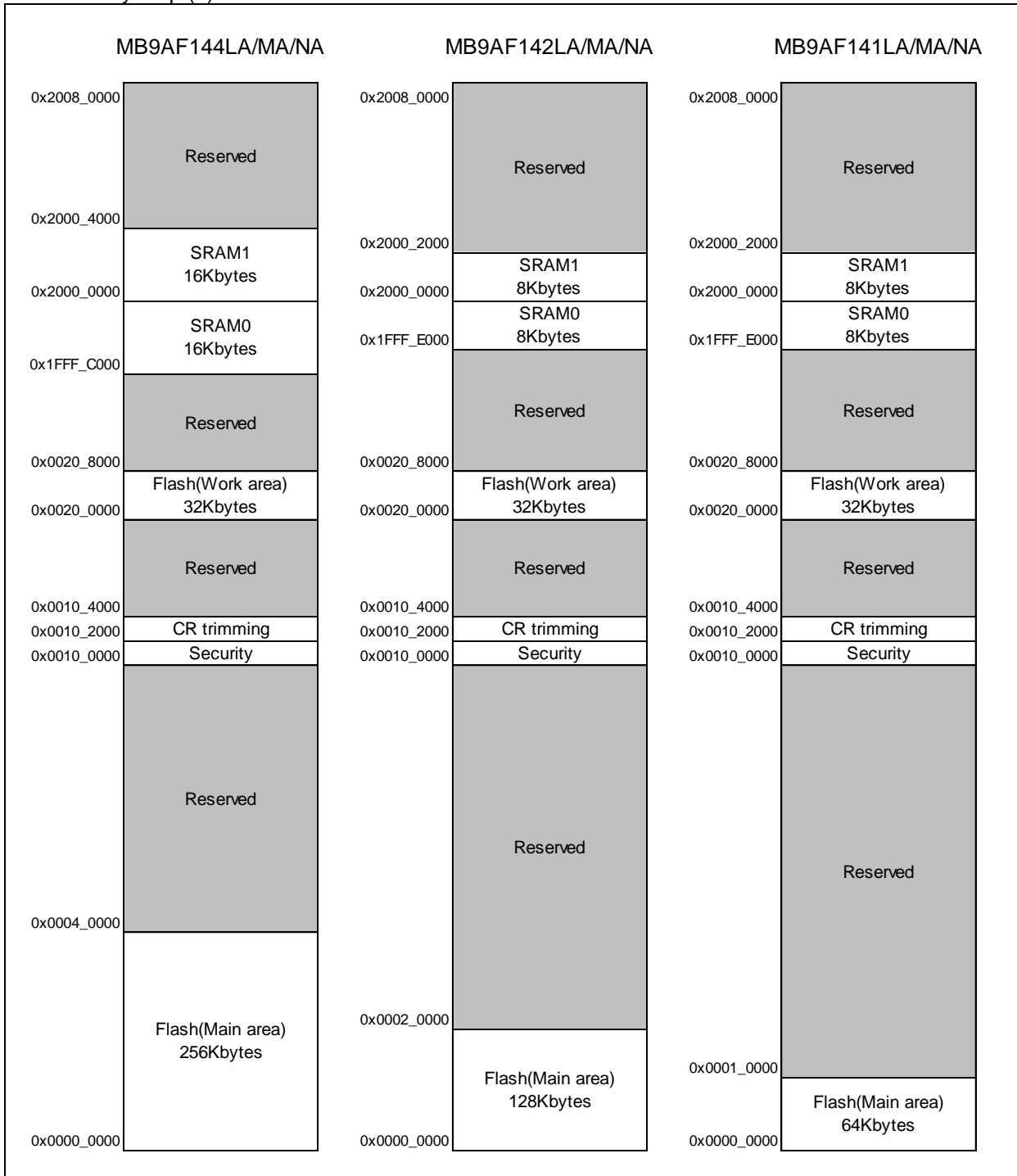

Refer to the programming manual for the detail of Flash main area.

- MB9AB40N/A40N/340N/140N/150R,MB9B520M/320M/120M Series Flash Programming Manual

● Peripheral Address Map

Start address	End address	Bus	Peripherals
0x4000_0000	0x4000_0FFF	AHB	Flash memory I/F register
0x4000_1000	0x4000_FFFF		Reserved
0x4001_0000	0x4001_0FFF	APB0	Clock/Reset Control
0x4001_1000	0x4001_1FFF		Hardware Watchdog timer
0x4001_2000	0x4001_2FFF		Software Watchdog timer
0x4001_3000	0x4001_4FFF		Reserved
0x4001_5000	0x4001_5FFF		Dual Timer
0x4001_6000	0x4001_FFFF		Reserved
0x4002_0000	0x4002_4FFF		APB1
0x4002_5000	0x4002_5FFF	Base Timer	
0x4002_6000	0x4002_6FFF	Reserved	
0x4002_7000	0x4002_7FFF	A/D Converter	
0x4002_8000	0x4002_DFFF	Reserved	
0x4002_E000	0x4002_EFFF	Built-in CR trimming	
0x4002_F000	0x4002_FFFF	Reserved	
0x4003_0000	0x4003_0FFF	APB2	External Interrupt
0x4003_1000	0x4003_1FFF		Interrupt Source Check Register
0x4003_2000	0x4003_2FFF		Reserved
0x4003_3000	0x4003_3FFF		GPIO
0x4003_4000	0x4003_4FFF		HDMI-CEC/Remote control Receiver
0x4003_5000	0x4003_57FF		Low-Voltage Detector
0x4003_5800	0x4003_5FFF		Deep standby mode Controller
0x4003_6000	0x4003_7FFF		Reserved
0x4003_8000	0x4003_8FFF		Multi-function serial
0x4003_9000	0x4003_9FFF		CRC
0x4003_A000	0x4003_AFFF		Watch Counter
0x4003_B000	0x4003_BFFF		Real-time clock
0x4003_C000	0x4003_EFFF		Reserved
0x4003_F000	0x4003_FFFF		External bus interface
0x4004_0000	0x4005_FFFF		AHB
0x4006_0000	0x4006_0FFF	DMAC register	
0x4006_1000	0x41FF_FFFF	Reserved	

■ PIN STATUS IN EACH CPU STATE

The terms used for pin status have the following meanings.

- INITX=0
This is the period when the INITX pin is the "L" level.
- INITX=1
This is the period when the INITX pin is the "H" level.
- SPL=0
This is the status that the standby pin level setting bit (SPL) in the standby mode control register (STB_CTL) is set to "0".
- SPL=1
This is the status that the standby pin level setting bit (SPL) in the standby mode control register (STB_CTL) is set to "1".
- Input enabled
Indicates that the input function can be used.
- Internal input fixed at "0"
This is the status that the input function cannot be used. Internal input is fixed at "L".
- Hi-Z
Indicates that the pin drive transistor is disabled and the pin is put in the Hi-Z state.
- Setting disabled
Indicates that the setting is disabled.
- Maintain previous state
Maintains the state that was immediately prior to entering the current mode.
If a built-in peripheral function is operating, the output follows the peripheral function.
If the pin is being used as a port, that output is maintained.
- Analog input is enabled
Indicates that the analog input is enabled.
- Trace output
Indicates that the trace function can be used.
- GPIO selected
In Deep standby mode, pins switch to the general-purpose I/O port.

● List of Pin Status

Pin status type	Function group	Power-on reset or low-voltage detection state	INITX input state	Device internal reset state	Run mode or SLEEP mode state	Timer mode, RTC mode, or STOP mode state		Deep standby RTC mode or Deep standby STOP mode state		Return from Deep standby mode state
		Power supply unstable	Power supply stable		Power supply stable	Power supply stable		Power supply stable		Power supply stable
		-	INITX = 0	INITX = 1	INITX = 1	INITX = 1		INITX = 1		INITX = 1
		-	-	-	-	SPL = 0	SPL = 1	SPL = 0	SPL = 1	-
A	GPIO selected	Setting disabled	Setting disabled	Setting disabled	Maintain previous state	Maintain previous state	Hi-Z / Internal input fixed at "0"	GPIO selected Internal input fixed at "0"	Hi-Z / Internal input fixed at "0"	GPIO selected
	Main crystal oscillator input pin/ External main clock input selected	Input enabled	Input enabled	Input enabled	Input enabled	Input enabled	Input enabled	Input enabled	Input enabled	Input enabled
B	GPIO selected	Setting disabled	Setting disabled	Setting disabled	Maintain previous state	Maintain previous state	Hi-Z / Internal input fixed at "0"	GPIO selected Internal input fixed at "0"	Hi-Z / Internal input fixed at "0"	GPIO selected
	External main clock input selected	Setting disabled	Setting disabled	Setting disabled	Maintain previous state	Maintain previous state	Hi-Z / Internal input fixed at "0"	Maintain previous state	Hi-Z / Internal input fixed at "0"	Maintain previous state
	Main crystal oscillator output pin	Hi-Z / Internal input fixed at "0" / or Input enable	Hi-Z / Internal input fixed at "0"	Hi-Z / Internal input fixed at "0"	Maintain previous state/When oscillation stops* ¹ , Hi-Z / Internal input fixed at "0"	Maintain previous state/When oscillation stops* ¹ , Hi-Z / Internal input fixed at "0"	Maintain previous state/When oscillation stops* ¹ , Hi-Z / Internal input fixed at "0"	Maintain previous state/When oscillation stops* ¹ , Hi-Z / Internal input fixed at "0"	Maintain previous state/When oscillation stops* ¹ , Hi-Z / Internal input fixed at "0"	Maintain previous state/When oscillation stops* ¹ , Hi-Z / Internal input fixed at "0"
C	INITX input pin	Pull-up / Input enabled	Pull-up / Input enabled	Pull-up / Input enabled	Pull-up / Input enabled	Pull-up / Input enabled	Pull-up / Input enabled	Pull-up / Input enabled	Pull-up / Input enabled	Pull-up / Input enabled
D	Mode input pin	Input enabled	Input enabled	Input enabled	Input enabled	Input enabled	Input enabled	Input enabled	Input enabled	Input enabled
E	Mode input pin	Input enabled	Input enabled	Input enabled	Input enabled	Input enabled	Input enabled	Input enabled	Input enabled	Input enabled
	GPIO selected	Setting disabled	Setting disabled	Setting disabled	Maintain previous state	Maintain previous state	Hi-Z / Input enabled	GPIO selected	Hi-Z / Input enabled	GPIO selected

Pin status type	Function group	Power-on reset or low-voltage detection state	INITX input state	Device internal reset state	Run mode or SLEEP mode state	Timer mode, RTC mode, or STOP mode state		Deep standby RTC mode or Deep standby STOP mode state		Return from Deep standby mode state
		Power supply unstable	Power supply stable		Power supply stable	Power supply stable		Power supply stable		Power supply stable
		-	INITX = 0	INITX = 1	INITX = 1	INITX = 1		INITX = 1		INITX = 1
		-	-	-	-	SPL = 0	SPL = 1	SPL = 0	SPL = 1	-
F	GPIO selected	Setting disabled	Setting disabled	Setting disabled	Maintain previous state	Maintain previous state	Hi-Z / Internal input fixed at "0"	GPIO selected Internal input fixed at "0"	Hi-Z / Internal input fixed at "0"	GPIO selected
	Sub crystal oscillator input pin / External sub clock input selected	Input enabled	Input enabled	Input enabled	Input enabled	Input enabled	Input enabled	Input enabled	Input enabled	Input enabled
G	GPIO selected	Setting disabled	Setting disabled	Setting disabled	Maintain previous state	Maintain previous state	Hi-Z / Internal input fixed at "0"	GPIO selected Internal input fixed at "0"	Hi-Z / Internal input fixed at "0"	GPIO selected
	External sub clock input selected	Setting disabled	Setting disabled	Setting disabled	Maintain previous state	Maintain previous state	Hi-Z / Internal input fixed at "0"	Maintain previous state	Hi-Z / Internal input fixed at "0"	Maintain previous state
	Sub crystal oscillator output pin	Hi-Z / Internal input fixed at "0" / or Input enable	Hi-Z / Internal input fixed at "0"	Hi-Z / Internal input fixed at "0"	Maintain previous state	Maintain previous state / When oscillation stops* ² , Hi-Z / Internal input fixed at "0"	Maintain previous state / When oscillation stops* ² , Hi-Z / Internal input fixed at "0"	Maintain previous state / When oscillation stops* ² , Hi-Z / Internal input fixed at "0"	Maintain previous state / When oscillation stops* ² , Hi-Z / Internal input fixed at "0"	Maintain previous state / When oscillation stops* ² , Hi-Z / Internal input fixed at "0"
H	GPIO selected	Hi-Z	Hi-Z / Input enabled	Hi-Z / Input enabled	Maintain previous state	Maintain previous state	Hi-Z / Internal input fixed at "0"	GPIO selected Internal input fixed at "0"	Hi-Z / Internal input fixed at "0"	GPIO selected

Pin status type	Function group	Power-on reset or low-voltage detection state	INITX input state	Device internal reset state	Run mode or SLEEP mode state	Timer mode, RTC mode, or STOP mode state		Deep standby RTC mode or Deep standby STOP mode state		Return from Deep standby mode state	
		Power supply unstable	Power supply stable		Power supply stable	Power supply stable		Power supply stable		Power supply stable	
		-	INITX = 0	INITX = 1	INITX = 1	INITX = 1		INITX = 1		INITX = 1	
		-	-	-	-	SPL = 0	SPL = 1	SPL = 0	SPL = 1	-	
I	NMIX selected	Setting disabled	Setting disabled	Setting disabled	Maintain previous state	Maintain previous state	Maintain previous state	WKUP input enabled	Hi-Z / WKUP input enabled	GPIO selected	
	Resource other than above selected	Hi-Z	Hi-Z / Input enabled	Hi-Z / Input enabled			Hi-Z / Internal input fixed at "0"				
	GPIO selected										
J	JTAG selected	Hi-Z	Pull-up / Input enabled	Pull-up / Input enabled	Maintain previous state	Maintain previous state	Maintain previous state	Maintain previous state	Maintain previous state	Maintain previous state	
	GPIO selected	Setting disabled	Setting disabled	Setting disabled			Hi-Z / Internal input fixed at "0"	GPIO selected Internal input fixed at "0"	Hi-Z / Internal input fixed at "0"	GPIO selected	
K	Resource selected	Hi-Z	Hi-Z / Input enabled	Hi-Z / Input enabled	Maintain previous state	Maintain previous state	Hi-Z / Internal input fixed at "0"	GPIO selected Internal input fixed at "0"	Hi-Z / Internal input fixed at "0"	GPIO selected	
	GPIO selected										
L	External interrupt enabled selected	Setting disabled	Setting disabled	Setting disabled	Maintain previous state	Maintain previous state	Maintain previous state	GPIO selected Internal input fixed at "0"	Hi-Z / Internal input fixed at "0"	GPIO selected	
	Resource other than above selected	Hi-Z	Hi-Z / Input enabled	Hi-Z / Input enabled			Hi-Z / Internal input fixed at "0"				
	GPIO selected										
M	Analog input selected	Hi-Z	Hi-Z / Internal input fixed at "0" / Analog input enabled	Hi-Z / Internal input fixed at "0" / Analog input enabled	Hi-Z / Internal input fixed at "0" / Analog input enabled	Hi-Z / Internal input fixed at "0" / Analog input enabled	Hi-Z / Internal input fixed at "0" / Analog input enabled	Hi-Z / Internal input fixed at "0" / Analog input enabled	Hi-Z / Internal input fixed at "0" / Analog input enabled	Hi-Z / Internal input fixed at "0" / Analog input enabled	
	Resource other than above selected		Setting disabled	Setting disabled	Setting disabled	Maintain previous state	Maintain previous state	Hi-Z / Internal input fixed at "0"	GPIO selected Internal input fixed at "0"	Hi-Z / Internal input fixed at "0"	GPIO selected
	GPIO selected										

Pin status type	Function group	Power-on reset or low-voltage detection state	INITX input state	Device internal reset state	Run mode or SLEEP mode state	Timer mode, RTC mode, or STOP mode state		Deep standby RTC mode or Deep standby STOP mode state		Return from Deep standby mode state
		Power supply unstable	Power supply stable		Power supply stable	Power supply stable		Power supply stable		Power supply stable
		-	INITX = 0	INITX = 1	INITX = 1	INITX = 1		INITX = 1		INITX = 1
		-	-	-	-	SPL = 0	SPL = 1	SPL = 0	SPL = 1	-
N	Analog input selected	Hi-Z	Hi-Z / Internal input fixed at "0" / Analog input enabled	Hi-Z / Internal input fixed at "0" / Analog input enabled	Hi-Z / Internal input fixed at "0" / Analog input enabled	Hi-Z / Internal input fixed at "0" / Analog input enabled	Hi-Z / Internal input fixed at "0" / Analog input enabled	Hi-Z / Internal input fixed at "0" / Analog input enabled	Hi-Z / Internal input fixed at "0" / Analog input enabled	Hi-Z / Internal input fixed at "0" / Analog input enabled
	External interrupt enabled selected	Setting disabled	Setting disabled	Setting disabled	Maintain previous state	Maintain previous state	Maintain previous state	GPIO selected Internal input fixed at "0"	Hi-Z / Internal input fixed at "0"	GPIO selected
	Resource other than above selected						Hi-Z / Internal input fixed at "0"			
GPIO selected	Hi-Z / Internal input fixed at "0"									
O	Trace selected	Setting disabled	Setting disabled	Setting disabled	Maintain previous state	Maintain previous state	Trace output	GPIO selected Internal input fixed at "0"	Hi-Z / Internal input fixed at "0"	GPIO selected
	Resource other than above selected	Hi-Z	Hi-Z / Input enabled	Hi-Z / Input enabled			Hi-Z / Internal input fixed at "0"			
	GPIO selected						Hi-Z / Internal input fixed at "0"			
P	Analog input selected				Hi-Z	Hi-Z / Internal input fixed at "0" / Analog input enabled	Hi-Z / Internal input fixed at "0" / Analog input enabled	Hi-Z / Internal input fixed at "0" / Analog input enabled	Hi-Z / Internal input fixed at "0" / Analog input enabled	Hi-Z / Internal input fixed at "0" / Analog input enabled
	Trace selected	Setting disabled	Setting disabled	Setting disabled	Maintain previous state	Maintain previous state	Trace output	GPIO selected Internal input fixed at "0"	Hi-Z / Internal input fixed at "0"	GPIO selected
	Resource other than above selected						Hi-Z / Internal input fixed at "0"			
GPIO selected	Hi-Z / Internal input fixed at "0"									

Pin status type	Function group	Power-on reset or low-voltage detection state	INITX input state	Device internal reset state	Run mode or SLEEP mode state	Timer mode, RTC mode, or STOP mode state		Deep standby RTC mode or Deep standby STOP mode state		Return from Deep standby mode state
		Power supply unstable	Power supply stable		Power supply stable	Power supply stable		Power supply stable		Power supply stable
		-	INITX = 0	INITX = 1	INITX = 1	INITX = 1		INITX = 1		INITX = 1
		-	-	-	-	SPL = 0	SPL = 1	SPL = 0	SPL = 1	-
Q	Analog input selected	Hi-Z	Hi-Z / Internal input fixed at "0" / Analog input enabled	Hi-Z / Internal input fixed at "0" / Analog input enabled	Hi-Z / Internal input fixed at "0" / Analog input enabled	Hi-Z / Internal input fixed at "0" / Analog input enabled	Hi-Z / Internal input fixed at "0" / Analog input enabled	Hi-Z / Internal input fixed at "0" / Analog input enabled	Hi-Z / Internal input fixed at "0" / Analog input enabled	Hi-Z / Internal input fixed at "0" / Analog input enabled
	Trace selected	Setting disabled	Setting disabled	Setting disabled	Maintain previous state	Maintain previous state	Trace output	GPIO selected Internal input fixed at "0"	Hi-Z / Internal input fixed at "0"	GPIO selected
	External interrupt enabled selected						Maintain previous state			
	Resource other than above selected						Hi-Z / Internal input fixed at "0"			
	GPIO selected						Hi-Z / Internal input fixed at "0"			
R	Analog input selected	Hi-Z	Hi-Z / Internal input fixed at "0" / Analog input enabled	Hi-Z / Internal input fixed at "0" / Analog input enabled	Hi-Z / Internal input fixed at "0" / Analog input enabled	Hi-Z / Internal input fixed at "0" / Analog input enabled	Hi-Z / Internal input fixed at "0" / Analog input enabled	Hi-Z / Internal input fixed at "0" / Analog input enabled	Hi-Z / Internal input fixed at "0" / Analog input enabled	Hi-Z / Internal input fixed at "0" / Analog input enabled
	WKUP enabled	Setting disabled	Setting disabled	Setting disabled	Maintain previous state	Maintain previous state	Maintain previous state	WKUP input enabled	Hi-Z / WKUP input enabled	GPIO selected
	External interrupt enabled selected						GPIO selected Internal input fixed at "0"	Hi-Z / Internal input fixed at "0"		
	Resource other than above selected						Hi-Z / Internal input fixed at "0"	Hi-Z / Internal input fixed at "0"		
	GPIO selected						Hi-Z / Internal input fixed at "0"	Hi-Z / Internal input fixed at "0"		
S	CEC enabled	Setting disabled	Setting disabled	Setting disabled	Maintain previous state	Maintain previous state	Maintain previous state	Maintain previous state	Maintain previous state	Maintain previous state
	Resource other than above selected	Hi-Z	Hi-Z / Input enabled	Hi-Z / Input enabled	Maintain previous state	Maintain previous state	Hi-Z / Internal input fixed at "0"	GPIO selected Internal input fixed at "0"	Hi-Z / Internal input fixed at "0"	GPIO selected
	GPIO selected						Hi-Z / Internal input fixed at "0"	Hi-Z / Internal input fixed at "0"		

Pin status type	Function group	Power-on reset or low-voltage detection state	INITX input state	Device internal reset state	Run mode or SLEEP mode state	Timer mode, RTC mode, or STOP mode state		Deep standby RTC mode or Deep standby STOP mode state		Return from Deep standby mode state
		Power supply unstable	Power supply stable		Power supply stable	Power supply stable		Power supply stable		Power supply stable
		-	INITX = 0	INITX = 1	INITX = 1	INITX = 1		INITX = 1		INITX = 1
		-	-	-	-	SPL = 0	SPL = 1	SPL = 0	SPL = 1	-
T	CEC enabled	Setting disabled	Setting disabled	Setting disabled	Maintain previous state	Maintain previous state	Maintain previous state	Maintain previous state	Maintain previous state	Maintain previous state
	WKUP enabled	Setting disabled	Setting disabled	Setting disabled	Maintain previous state	Maintain previous state	Maintain previous state	WKUP input enabled	Hi-Z / WKUP input enabled	GPIO selected
	External interrupt enabled selected							GPIO selected	Hi-Z / Internal input fixed at "0"	
	Resource other than above selected	Hi-Z	Hi-Z / Input enabled	Hi-Z / Input enabled	Maintain previous state	Maintain previous state	Hi-Z / Internal input fixed at "0"	Internal input fixed at "0"	Internal input fixed at "0"	
	GPIO selected									

*1 : Oscillation is stopped at Sub timer mode, Low-speed CR timer mode, RTC mode, STOP mode, Deep standby RTC mode, and Deep standby STOP mode.

*2 : Oscillation is stopped at STOP mode and Deep standby STOP mode.

■ ELECTRICAL CHARACTERISTICS

1. Absolute Maximum Ratings

Parameter	Symbol	Rating		Unit	Remarks
		Min	Max		
Power supply voltage* ¹ , * ²	V_{CC}	$V_{SS} - 0.5$	$V_{SS} + 4.6$	V	
Analog power supply voltage* ¹ , * ³	AV_{CC}	$V_{SS} - 0.5$	$V_{SS} + 4.6$	V	
Analog reference voltage* ¹ , * ³	AV_{RH}	$V_{SS} - 0.5$	$V_{SS} + 4.6$	V	
Input voltage* ¹	V_I	$V_{SS} - 0.5$	$V_{CC} + 0.5$ ($\leq 4.6V$)	V	
		$V_{SS} - 0.5$	$V_{SS} + 6.5$	V	5V tolerant
Analog pin input voltage* ¹	V_{IA}	$V_{SS} - 0.5$	$AV_{CC} + 0.5$ ($\leq 4.6V$)	V	
Output voltage* ¹	V_O	$V_{SS} - 0.5$	$V_{CC} + 0.5$ ($\leq 4.6V$)	V	
"L" level maximum output current* ⁴	I_{OL}	-	10	mA	
			39	mA	P80/P81 pins
"L" level average output current* ⁵	I_{OLAV}	-	4	mA	
			10.5	mA	P80/P81 pins
"L" level total maximum output current	$\sum I_{OL}$	-	100	mA	
"L" level total average output current* ⁶	$\sum I_{OLAV}$	-	50	mA	
"H" level maximum output current* ⁴	I_{OH}	-	- 10	mA	
			- 39	mA	P80/P81 pins
"H" level average output current* ⁵	I_{OHAV}	-	- 4	mA	
			- 12	mA	P80/P81 pins
"H" level total maximum output current	$\sum I_{OH}$	-	- 100	mA	
"H" level total average output current* ⁶	$\sum I_{OHAV}$	-	- 50	mA	
Power consumption	P_D	-	300	mW	
Storage temperature	T_{STG}	- 55	+ 150	°C	

*1 : These parameters are based on the condition that $V_{SS} = AV_{SS} = 0V$.

*2 : V_{CC} must not drop below $V_{SS} - 0.5V$.

*3 : Ensure that the voltage does not exceed $V_{CC} + 0.5 V$, for example, when the power is turned on.

*4 : The maximum output current is defined as the value of the peak current flowing through any one of the corresponding pins.

*5 : The average output current is defined as the average current value flowing through any one of the corresponding pins for a 100 ms period.

*6 : The total average output current is defined as the average current value flowing through all of corresponding pins for a 100ms.

<WARNING>

Semiconductor devices may be permanently damaged by application of stress (including, without limitation, voltage, current or temperature) in excess of absolute maximum ratings.

Do not exceed any of these ratings.

2. Recommended Operating Conditions

($V_{SS} = AV_{SS} = 0.0V$)

Parameter	Symbol	Conditions	Value		Unit	Remarks
			Min	Max		
Power supply voltage	V_{CC}	-	1.65	3.6	V	
Analog power supply voltage	AV_{CC}	-	1.65	3.6	V	$AV_{CC} = V_{CC}$
Analog reference voltage	AVRH	-	2.7	AV_{CC}	V	$AV_{CC} \geq 2.7V$
			AV_{CC}	AV_{CC}	V	$AV_{CC} < 2.7V$
Smoothing capacitor	C_S	-	1	10	μF	For Regulator *
Operating temperature	T_a	-	- 40	+ 85	$^{\circ}C$	

* : See "•C Pin" in "■ HANDLING DEVICES" for the connection of the smoothing capacitor.

<WARNING>

The recommended operating conditions are required in order to ensure the normal operation of the semiconductor device. All of the device's electrical characteristics are warranted when the device is operated under these conditions.

Any use of semiconductor devices will be under their recommended operating condition.

Operation under any conditions other than these conditions may adversely affect reliability of device and could result in device failure.

No warranty is made with respect to any use, operating conditions or combinations not represented on this data sheet. If you are considering application under any conditions other than listed herein, please contact sales representatives beforehand.

3. DC Characteristics

(1) Current rating

 $(V_{CC} = AV_{CC} = 1.65V \text{ to } 3.6V, V_{SS} = AV_{SS} = 0V, T_a = -40^{\circ}C \text{ to } +85^{\circ}C)$

Parameter	Symbol	Pin name	Conditions	Value			Unit	Remarks
				Min	Typ	Max		
Power supply current	I _{CC}	VCC	Normal operation (PLL)	-	15.5	21	mA	CPU : 40 MHz, Peripheral : 40 MHz *1
				-	8.7	12	mA	CPU : 40 MHz, Peripheral : the clock stops NOP operation *1
			Normal operation (built-in high-speed CR)	-	1.8	2.9	mA	CPU/ Peripheral : 4 MHz*2 *1
			Normal operation (sub oscillation)	-	110	680	μA	CPU/ Peripheral : 32 kHz *1
			Normal operation (built-in low-speed CR)	-	125	700	μA	CPU/ Peripheral : 100 kHz *1
	I _{CCS}		SLEEP operation (PLL)	-	9	12.5	mA	Peripheral : 40 MHz *1
			SLEEP operation (built-in high-speed CR)	-	0.8	1.6	mA	Peripheral : 4 MHz*2 *1
			SLEEP operation (sub oscillation)	-	96	670	μA	Peripheral : 32 kHz *1
			SLEEP operation (built-in low-speed CR)	-	110	680	μA	Peripheral : 100 kHz *1
	I _{CCH}		STOP mode	-	9	28	μA	T _a = + 25°C, When LVD is off *1
				-	-	270	μA	T _a = + 85°C, When LVD is off *1
	I _{CCT}		TIMER mode (sub oscillation)	-	12	35	μA	T _a = + 25°C, When LVD is off *1
				-	-	330	μA	T _a = + 85°C, When LVD is off *1
	I _{CCR}		RTC mode (sub oscillation)	-	9.8	29	μA	T _a = + 25°C, When LVD is off *1
				-	-	280	μA	T _a = + 85°C, When LVD is off *1

Parameter	Symbol	Pin name	Conditions	Value			Unit	Remarks	
				Min	Typ	Max			
Power supply current	I _{CCHD}	VCC	Deep Standby STOP mode	-	1.25	7	μA	Ta = + 25°C, When LVD is off, RAM hold off *1, *3	
				-	5.3	18	μA	Ta = + 25°C, When LVD is off, RAM hold on *1, *3	
				-	-	70	μA	Ta = + 85°C, When LVD is off, RAM hold off *1, *3	
				-	-	100	μA	Ta = + 85°C, When LVD is off, RAM hold on *1, *3	
	I _{CCRD}		Deep Standby RTC mode (sub oscillation)	-	1.9	9	μA	Ta = + 25°C, When LVD is off, RAM hold off *1, *3	
				-	5.9	20	μA	Ta = + 25°C, When LVD is off, RAM hold on *1, *3	
				-	-	75	μA	Ta = + 85°C, When LVD is off, RAM hold off *1, *3	
				-	-	105	μA	Ta = + 85°C, When LVD is off, RAM hold on *1, *3	
	Low-voltage detection circuit (LVD) power supply current		I _{CCLVD}	At operation	-	0.13	0.3	μA	For occurrence of reset
					-	0.13	0.3	μA	For occurrence of interrupt
Flash memory write/erase current	I _{CCFLASH}	At Write/Erase	-	9.5	11.2	mA	*4		

*1: When all ports are fixed.

*2: When setting it to 4 MHz by trimming.

*3: RAM hold setting is on-chip SRAM only.

*4: The current at which to write or erase Flash memory, "I_{CCFLASH}" is added to "I_{CC}".

(2) Pin Characteristics

($V_{CC} = AV_{CC} = 1.65V$ to $3.6V$, $V_{SS} = AV_{SS} = 0V$, $T_a = -40^{\circ}C$ to $+85^{\circ}C$)

Parameter	Symbol	Pin name	Conditions	Value			Unit	Remarks
				Min	Typ	Max		
"H" level input voltage (hysteresis input)	V_{IHS}	CMOS hysteresis input pin, MD0, MD1	$V_{CC} \geq 2.7 V$	$V_{CC} \times 0.8$	-	$V_{CC} + 0.3$	V	
			$V_{CC} < 2.7 V$	$V_{CC} \times 0.7$				
		5V tolerant input pin	$V_{CC} \geq 2.7 V$	$V_{CC} \times 0.8$	-	$V_{SS} + 5.5$	V	
			$V_{CC} < 2.7 V$	$V_{CC} \times 0.7$				
"L" level input voltage (hysteresis input)	V_{ILS}	CMOS hysteresis input pin, MD0, MD1	$V_{CC} \geq 2.7 V$	$V_{SS} - 0.3$	-	$V_{CC} \times 0.2$	V	
			$V_{CC} < 2.7 V$			$V_{CC} \times 0.3$		
		5V tolerant input pin	$V_{CC} \geq 2.7 V$	$V_{SS} - 0.3$	-	$V_{CC} \times 0.2$	V	
			$V_{CC} < 2.7 V$			$V_{CC} \times 0.3$		
"H" level output voltage	V_{OH}	4mA type	$V_{CC} \geq 2.7 V$, $I_{OH} = -4mA$	$V_{CC} - 0.5$	-	V_{CC}	V	
			$V_{CC} < 2.7 V$, $I_{OH} = -2mA$	$V_{CC} - 0.45$				
		P80/P81	$V_{CC} \geq 2.7 V$, $I_{OH} = -12mA$	$V_{CC} - 0.4$	-	V_{CC}	V	
			$V_{CC} < 2.7 V$, $I_{OH} = -6.5mA$					

Parameter	Symbol	Pin name	Conditions	Value			Unit	Remarks
				Min	Typ	Max		
"L" level output voltage	V _{OL}	4mA type	V _{CC} ≥ 2.7 V, I _{OL} = 4mA	V _{SS}	-	0.4	V	
			V _{CC} < 2.7 V, I _{OL} = 2mA					
		P80/P81	V _{CC} ≥ 2.7 V, I _{OL} = 10.5mA	V _{SS}	-	0.4	V	
			V _{CC} < 2.7 V, I _{OL} = 5mA					
Input leak current	I _{IL}	-	-	- 5	-	+ 5	μA	
Pull-up resistor value	R _{PU}	Pull-up pin	V _{CC} ≥ 2.7 V	21	33	66	kΩ	
			V _{CC} < 2.7 V	-	-	134		
Input capacitance	C _{IN}	Other than VCC, VSS, AVCC, AVSS, AVRH	-	-	5	15	pF	

4. AC Characteristics

(1) Main Clock Input Characteristics

($V_{CC} = 1.65V$ to $3.6V$, $V_{SS} = 0V$, $T_a = -40^{\circ}C$ to $+85^{\circ}C$)

Parameter	Symbol	Pin name	Conditions	Value		Unit	Remarks
				Min	Max		
Input frequency	F_{CH}	X0, X1	$V_{CC} \geq 2.7V$	4	48	MHz	When crystal oscillator is connected
			$V_{CC} < 2.7V$	4	20		
			-	4	48	MHz	When using external clock
Input clock cycle	t_{CYLH}		-	20.83	250	ns	When using external clock
Input clock pulse width	-		P_{WH}/t_{CYLH} , P_{WL}/t_{CYLH}	45	55	%	When using external clock
Input clock rising time and falling time	t_{CF} , t_{CR}		-	-	5	ns	When using external clock
Internal operating clock* ¹ frequency	F_{CM}	-	-	-	40	MHz	Master clock
	F_{CC}	-	-	-	40	MHz	Base clock (HCLK/FCLK)
	F_{CP0}	-	-	-	40	MHz	APB0 bus clock* ²
	F_{CP1}	-	-	-	40	MHz	APB1 bus clock* ²
	F_{CP2}	-	-	-	40	MHz	APB2 bus clock* ²
Internal operating clock* ¹ cycle time	t_{CYCC}	-	-	25	-	ns	Base clock (HCLK/FCLK)
	t_{CYCP0}	-	-	25	-	ns	APB0 bus clock* ²
	t_{CYCP1}	-	-	25	-	ns	APB1 bus clock* ²
	t_{CYCP2}	-	-	25	-	ns	APB2 bus clock* ²

*1: For more information about each internal operating clock, see "Chapter: Clock" in "FM3 Family PERIPHERAL MANUAL".

*2: For about each APB bus which each peripheral is connected to, see "■ BLOCK DIAGRAM" in this data sheet.

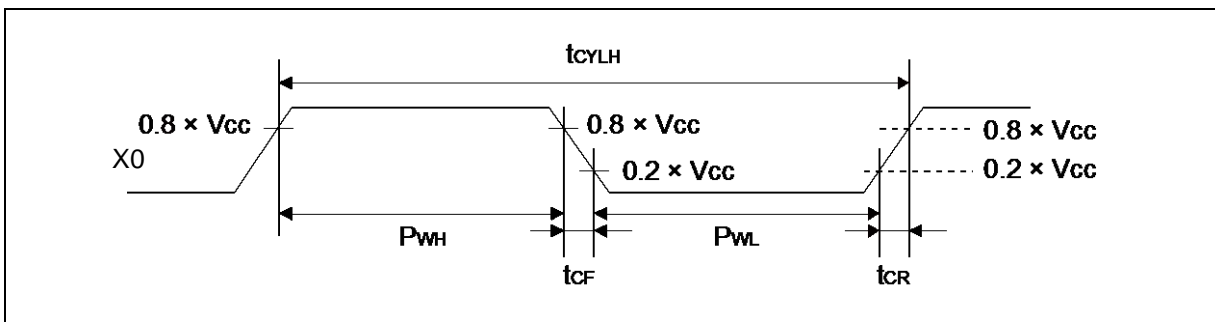

(2) Sub Clock Input Characteristics

($V_{CC} = 1.65V$ to $3.6V$, $V_{SS} = 0V$, $T_a = -40^{\circ}C$ to $+85^{\circ}C$)

Parameter	Symbol	Pin name	Conditions	Value			Unit	Remarks
				Min	Typ	Max		
Input frequency	F_{CL}	X0A, X1A	-	-	32.768	-	kHz	When crystal oscillator is connected
			-	32	-	100		kHz
Input clock cycle	t_{CYLL}		-	10	-	31.25	μs	When using external clock
Input clock pulse width	-		P_{WH}/t_{CYLL} , P_{WL}/t_{CYLL}	45	-	55	%	When using external clock

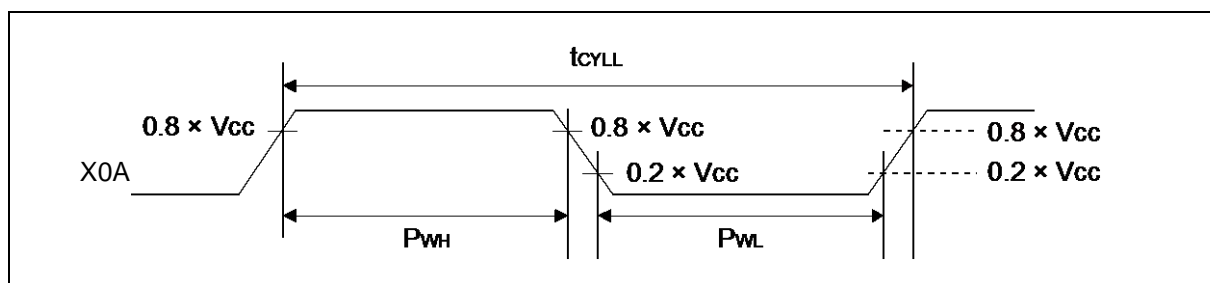

(3) Built-in CR Oscillation Characteristics

- Built-in high-speed CR

($V_{CC} = 1.65V$ to $3.6V$, $V_{SS} = 0V$, $T_a = -40^{\circ}C$ to $+85^{\circ}C$)

Parameter	Symbol	Conditions	Value			Unit	Remarks
			Min	Typ	Max		
Clock frequency	F_{CRH}	$T_a = +25^{\circ}C$ $V_{CC} \geq 2.7V$	3.96	4	4.04	MHz	When trimming*1
		$T_a = +25^{\circ}C$ $V_{CC} < 2.7V$	3.9	4	4.1		
		$T_a = -40^{\circ}C$ to $+85^{\circ}C$	3.84	4	4.16		When not trimming
		$T_a = -40^{\circ}C$ to $+85^{\circ}C$	2.8	4	5.2		
Frequency stabilization time	t_{CRWT}	-	-	-	30	μs	*2

*1: In the case of using the values in CR trimming area of Flash memory at shipment for frequency trimming.

*2: This is the time to stabilize the frequency of high-speed CR clock after setting trimming value.

This period is able to use high-speed CR clock as source clock.

- Built-in low-speed CR

($V_{CC} = 1.65V$ to $3.6V$, $V_{SS} = 0V$, $T_a = -40^{\circ}C$ to $+85^{\circ}C$)

Parameter	Symbol	Conditions	Value			Unit	Remarks
			Min	Typ	Max		
Clock frequency	F_{CRL}	-	50	100	150	kHz	

(4-1) Operating Conditions of Main PLL (In the case of using main clock for input of PLL)

($V_{CC} = 1.65V$ to $3.6V$, $V_{SS} = 0V$, $T_a = -40^{\circ}C$ to $+85^{\circ}C$)

Parameter	Symbol	Value			Unit	Remarks
		Min	Typ	Max		
PLL oscillation stabilization wait time* ¹ (LOCK UP time)	t_{LOCK}	100	-	-	μs	
PLL input clock frequency	F_{PLLI}	4	-	16	MHz	
PLL multiple rate	-	5	-	37	multiple	
PLL macro oscillation clock frequency	F_{PLLO}	75	-	150	MHz	
Main PLL clock frequency* ²	F_{CLKPLL}	-	-	40	MHz	

*1: Time from when the PLL starts operating until the oscillation stabilizes.

*2: For more information about Main PLL clock (CLKPLL), see "Chapter: Clock" in "FM3 Family PERIPHERAL MANUAL".

(4-2) Operating Conditions of Main PLL (In the case of using the built-in high-speed CR for the input clock of the main PLL)

($V_{CC} = 1.65V$ to $3.6V$, $V_{SS} = 0V$, $T_a = -40^{\circ}C$ to $+85^{\circ}C$)

Parameter	Symbol	Value			Unit	Remarks
		Min	Typ	Max		
PLL oscillation stabilization wait time* ¹ (LOCK UP time)	t_{LOCK}	100	-	-	μs	
PLL input clock frequency	F_{PLLI}	3.8	4	4.2	MHz	
PLL multiple rate	-	19	-	35	multiple	
PLL macro oscillation clock frequency	F_{PLLO}	72	-	150	MHz	
Main PLL clock frequency* ²	F_{CLKPLL}	-	-	40	MHz	

*1: Time from when the PLL starts operating until the oscillation stabilizes.

*2: For more information about Main PLL clock (CLKPLL), see "Chapter: Clock" in "FM3 Family PERIPHERAL MANUAL".

Note: Make sure to input to the main PLL source clock, the high-speed CR clock (CLKHC) that the frequency has been trimmed.

(5) Reset Input Characteristics

($V_{CC} = 1.65V$ to $3.6V$, $V_{SS} = 0V$, $T_a = -40^{\circ}C$ to $+85^{\circ}C$)

Parameter	Symbol	Pin name	Conditions	Value		Unit	Remarks
				Min	Max		
Reset input time	t_{INITX}	INITX	-	500	-	ns	

(6) Power-on Reset Timing

($V_{CC} = 1.65V$ to $3.6V$, $V_{SS} = 0V$, $T_a = -40^{\circ}C$ to $+85^{\circ}C$)

Parameter	Symbol	Pin name	Value		Unit	Remarks
			Min	Max		
Power supply rising time	T_r	VCC	0	-	ms	
Power supply shut down time	T_{off}		1	-	ms	

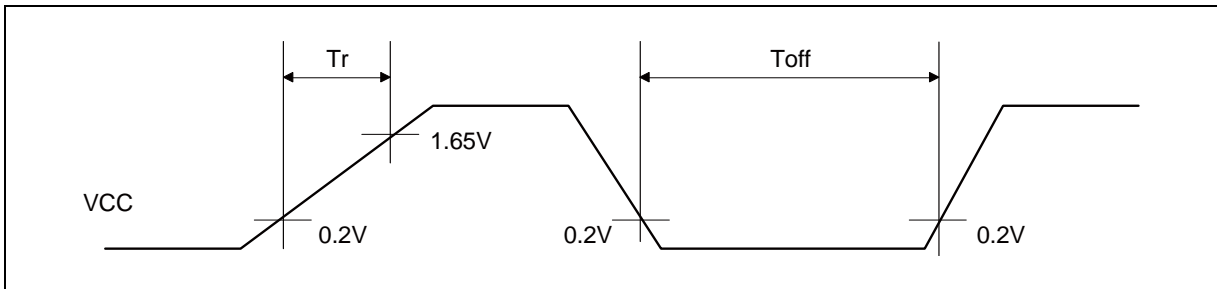

(7) External Bus Timing

- External bus clock output characteristics

($V_{CC} = 1.65V$ to $3.6V$, $V_{SS} = 0V$, $T_a = -40^{\circ}C$ to $+85^{\circ}C$)

Parameter	Symbol	Pin name	Conditions	Value		Unit
				Min	Max	
Output frequency	t_{CYCLE}	MCLKOUT*	$V_{CC} \geq 2.7V$	-	40	MHz
			$V_{CC} < 2.7V$	-	20	MHz

*: The external bus clock (MCLKOUT) is a divided clock of HCLK.

For more information about setting of clock divider, see "Chapter: External Bus Interface" in "FM3 Family PERIPHERAL MANUAL".

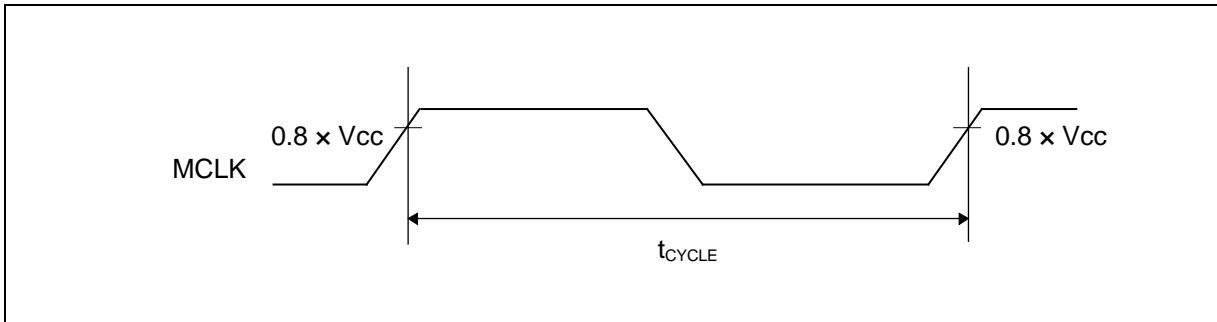

- External bus signal input/output characteristics

($V_{CC} = 1.65V$ to $3.6V$, $V_{SS} = 0V$, $T_a = -40^{\circ}C$ to $+85^{\circ}C$)

Parameter	Symbol	Conditions	Value	Unit	Remarks
Signal input characteristics	V_{IH}	-	$0.8 \times V_{CC}$	V	
	V_{IL}		$0.2 \times V_{CC}$	V	
Signal output characteristics	V_{OH}		$0.8 \times V_{CC}$	V	
	V_{OL}		$0.2 \times V_{CC}$	V	

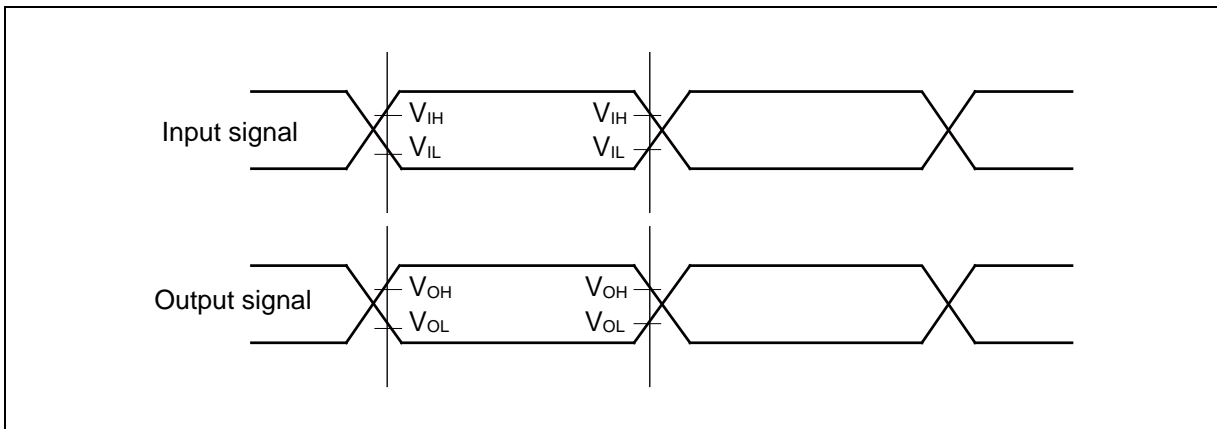

• Separate Bus Access Asynchronous SRAM Mode

($V_{CC} = 1.65V$ to $3.6V$, $V_{SS} = 0V$, $T_a = -40^{\circ}C$ to $+85^{\circ}C$)

Parameter	Symbol	Pin name	Conditions	Value		Unit
				Min	Max	
MOEX Min pulse width	$t_{OE\overline{W}}$	MOEX	$V_{CC} \geq 2.7V$ $V_{CC} < 2.7V$	MCLK \times n-3	-	ns
MCSX $\downarrow \rightarrow$ Address output delay time	t_{CSL-AV}	MCSX[7:0], MAD[24:0]	$V_{CC} \geq 2.7V$ $V_{CC} < 2.7V$	-9 -12	+9 +12	ns
MOEX $\uparrow \rightarrow$ Address hold time	$t_{OE\overline{H}-AX}$	MOEX, MAD[24:0]	$V_{CC} \geq 2.7V$ $V_{CC} < 2.7V$	0	MCLK \times m+9 MCLK \times m+12	ns
MCSX $\downarrow \rightarrow$ MOEX \downarrow delay time	$t_{CSL-OEL}$	MOEX, MCSX[7:0]	$V_{CC} \geq 2.7V$ $V_{CC} < 2.7V$	MCLK \times m-9 MCLK \times m-12	MCLK \times m+9 MCLK \times m+12	ns
MOEX $\uparrow \rightarrow$ MCSX \uparrow time	$t_{OE\overline{H}-CSH}$		$V_{CC} \geq 2.7V$ $V_{CC} < 2.7V$	0	MCLK \times m+9 MCLK \times m+12	ns
MCSX $\downarrow \rightarrow$ MDQM \downarrow delay time	$t_{CSL-RDQML}$	MCSX, MDQM[1:0]	$V_{CC} \geq 2.7V$ $V_{CC} < 2.7V$	MCLK \times m-9 MCLK \times m-12	MCLK \times m+9 MCLK \times m+12	ns
Data set up \rightarrow MOEX \uparrow time	t_{DS-OE}	MOEX, MADATA[15:0]	$V_{CC} \geq 2.7V$ $V_{CC} < 2.7V$	30 38	- -	ns
MOEX $\uparrow \rightarrow$ Data hold time	t_{DH-OE}	MOEX, MADATA[15:0]	$V_{CC} \geq 2.7V$ $V_{CC} < 2.7V$	0	-	ns
MWEX Min pulse width	$t_{WE\overline{W}}$	MWEX	$V_{CC} \geq 2.7V$ $V_{CC} < 2.7V$	MCLK \times n-3	-	ns
MWEX $\uparrow \rightarrow$ Address output delay time	$t_{WE\overline{H}-AX}$	MWEX, MAD[24:0]	$V_{CC} \geq 2.7V$ $V_{CC} < 2.7V$	0	MCLK \times m+9 MCLK \times m+12	ns
MCSX $\downarrow \rightarrow$ MWEX \downarrow delay time	$t_{CSL-WEL}$	MWEX, MCSX[7:0]	$V_{CC} \geq 2.7V$ $V_{CC} < 2.7V$	MCLK \times n-9 MCLK \times n-12	MCLK \times n+9 MCLK \times n+12	ns
MWEX $\uparrow \rightarrow$ MCSX \uparrow delay time	$t_{WE\overline{H}-CSH}$		$V_{CC} \geq 2.7V$ $V_{CC} < 2.7V$	0	MCLK \times m+9 MCLK \times m+12	ns
MCSX $\downarrow \rightarrow$ MDQM \downarrow delay time	$t_{CSL-WDQML}$	MCSX, MDQM[1:0]	$V_{CC} \geq 2.7V$ $V_{CC} < 2.7V$	MCLK \times n-9 MCLK \times n-12	MCLK \times n+9 MCLK \times n+12	ns
MWEX $\downarrow \rightarrow$ Data output time	t_{CSL-DV}	MCSX, MADATA[15:0]	$V_{CC} \geq 2.7V$ $V_{CC} < 2.7V$	MCLK-9 MCLK-12	MCLK+9 MCLK+12	ns
MWEX $\uparrow \rightarrow$ Data hold time	$t_{WE\overline{H}-DX}$	MWEX, MADATA[15:0]	$V_{CC} \geq 2.7V$ $V_{CC} < 2.7V$	0	MCLK \times m+9 MCLK \times m+12	ns

Note: When the external load capacitance $C_L = 30pF$. (m = 0 to 15, n = 1 to 16)

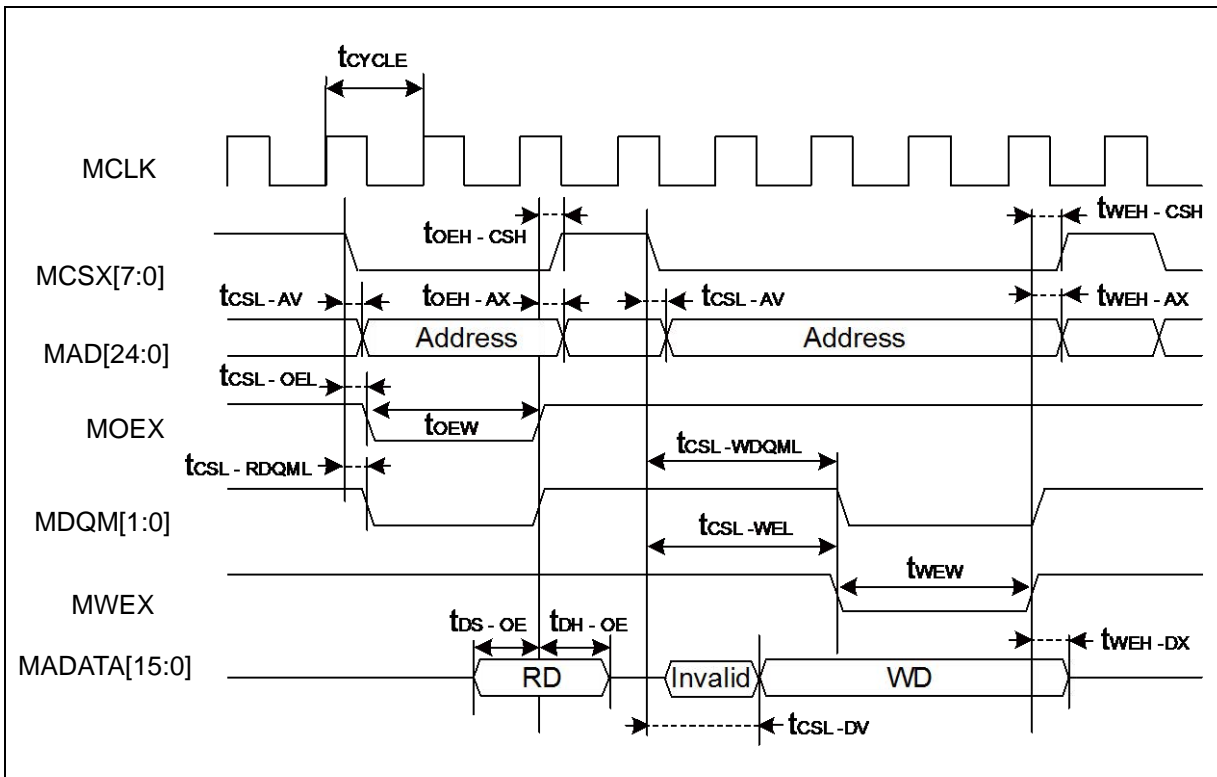

• Separate Bus Access Synchronous SRAM Mode

($V_{CC} = 1.65V$ to $3.6V$, $V_{SS} = 0V$, $T_a = -40^{\circ}C$ to $+85^{\circ}C$)

Parameter	Symbol	Pin name	Conditions	Value		Unit
				Min	Max	
Address delay time	t_{AV}	MCLK, MAD[24:0]	$V_{CC} \geq 2.7V$	1	12	ns
			$V_{CC} < 2.7V$		13	
MCSX delay time	t_{CSL}	MCLK, MCSX[7:0]	$V_{CC} \geq 2.7V$	1	12	ns
			$V_{CC} < 2.7V$			
	t_{CSH}		$V_{CC} \geq 2.7V$	1	12	ns
			$V_{CC} < 2.7V$			
MOEX delay time	t_{REL}	MCLK, MOEX	$V_{CC} \geq 2.7V$	1	9	ns
			$V_{CC} < 2.7V$		12	
	t_{REH}		$V_{CC} \geq 2.7V$	1	9	ns
			$V_{CC} < 2.7V$		12	
Data set up → MCLK ↑ time	t_{DS}	MCLK, MADATA[15:0]	$V_{CC} \geq 2.7V$	24	-	ns
			$V_{CC} < 2.7V$	37		
MCLK ↑ → Data hold time	t_{DH}	MCLK, MADATA[15:0]	$V_{CC} \geq 2.7V$	0	-	ns
			$V_{CC} < 2.7V$			
MWEX delay time	t_{WEL}	MCLK, MWEX	$V_{CC} \geq 2.7V$	1	9	ns
			$V_{CC} < 2.7V$		12	
	t_{WEH}		$V_{CC} \geq 2.7V$	1	9	ns
			$V_{CC} < 2.7V$		12	
MDQM[1:0] delay time	t_{DQML}	MCLK, MDQM[1:0]	$V_{CC} \geq 2.7V$	1	9	ns
			$V_{CC} < 2.7V$		12	
	t_{DQMH}		$V_{CC} \geq 2.7V$	1	9	ns
			$V_{CC} < 2.7V$		12	
MCLK ↑ → Data output time	t_{ODS}	MCLK, MADATA[15:0]	$V_{CC} \geq 2.7V$	MCLK + 1	MCLK + 18	ns
			$V_{CC} < 2.7V$		MCLK + 24	
MCLK ↑ → Data hold time	t_{OD}	MCLK, MADATA[15:0]	$V_{CC} \geq 2.7V$	1	18	ns
			$V_{CC} < 2.7V$		24	

Note: When the external load capacitance $C_L = 30pF$.

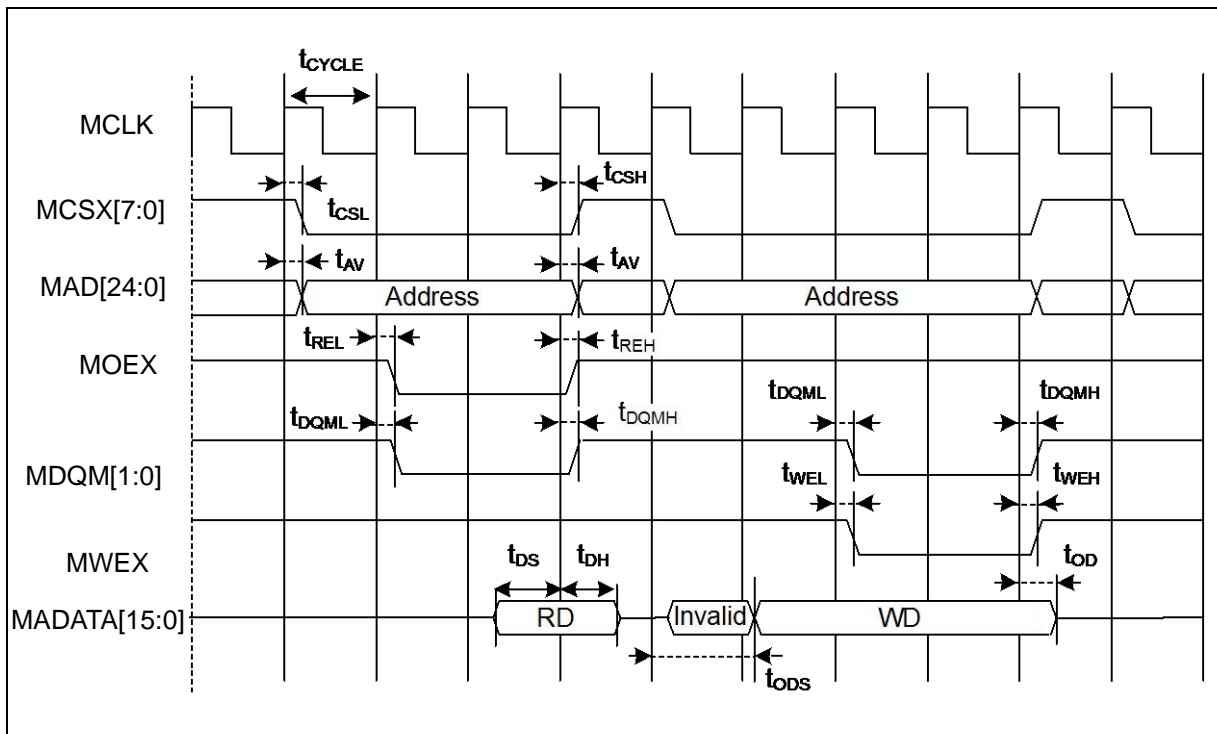

• Multiplexed Bus Access Asynchronous SRAM Mode

($V_{CC} = 1.65V$ to $3.6V$, $V_{SS} = 0V$, $T_a = -40^{\circ}C$ to $+85^{\circ}C$)

Parameter	Symbol	Pin name	Conditions	Value		Unit
				Min	Max	
Multiplexed address delay time	$t_{ALE-CHMADV}$	MALE, MADATA[15:0]	$V_{CC} \geq 2.7V$	-2	+10	ns
			$V_{CC} < 2.7V$		+20	
Multiplexed address hold time	t_{CHMADH}	MALE, MADATA[15:0]	$V_{CC} \geq 2.7V$	$MCLK \times n + 0$	$MCLK \times n + 10$	ns
			$V_{CC} < 2.7V$	$MCLK \times n + 0$	$MCLK \times n + 20$	

Note: When the external load capacitance $C_L = 30pF$. ($m = 0$ to 15 , $n = 1$ to 16)

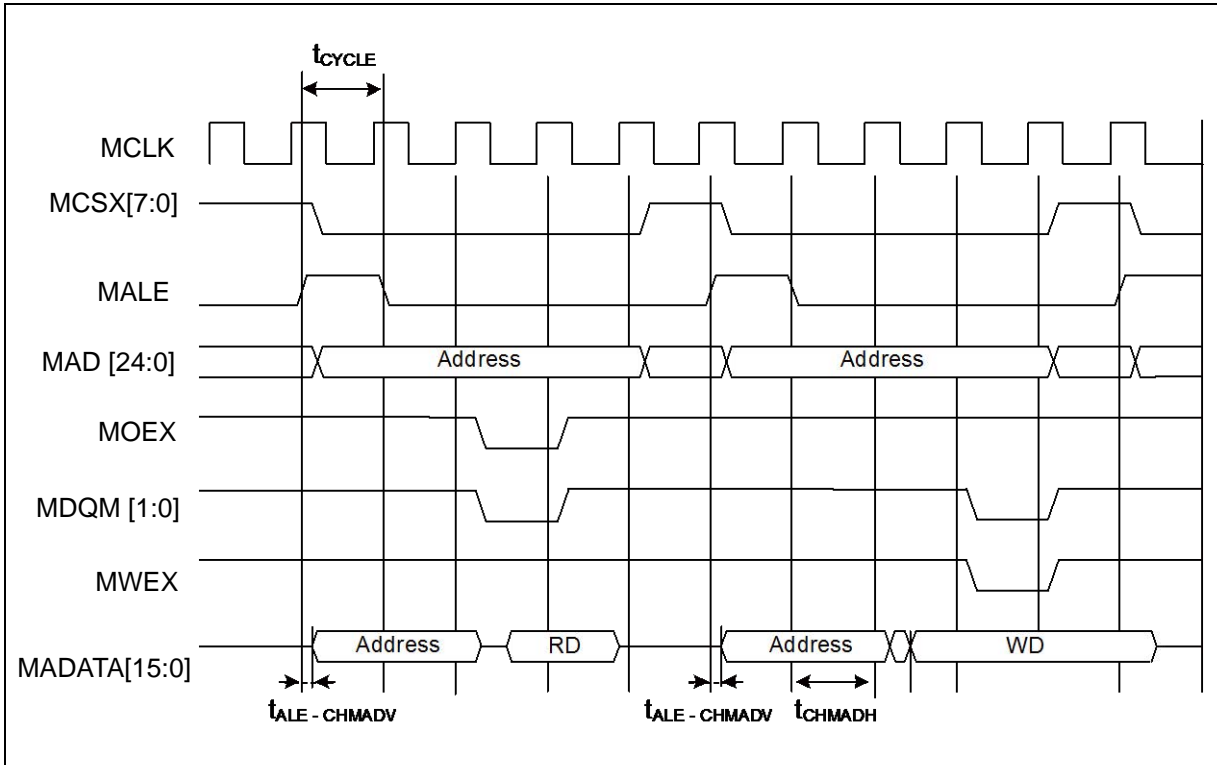

• Multiplexed Bus Access Synchronous SRAM Mode

($V_{CC} = 1.65V$ to $3.6V$, $V_{SS} = 0V$, $T_a = -40^{\circ}C$ to $+85^{\circ}C$)

Parameter	Symbol	Pin name	Conditions	Value		Unit	Remarks
				Min	Max		
MALE delay time	t_{CHAL}	MCLK, ALE	$V_{CC} \geq 2.7V$	1	9	ns	
			$V_{CC} < 2.7V$		12		
	t_{CHAH}		$V_{CC} \geq 2.7V$	1	9	ns	
			$V_{CC} < 2.7V$		12		
MCLK $\uparrow \rightarrow$ Multiplexed Address delay time	t_{CHMADV}	MCLK, MADATA[15:0]	$V_{CC} \geq 2.7V$	1	t_{OD}	ns	
	$V_{CC} < 2.7V$						
MCLK $\uparrow \rightarrow$ Multiplexed Data output time	t_{CHMADX}		$V_{CC} \geq 2.7V$	1	t_{OD}	ns	
		$V_{CC} < 2.7V$					

Note: When the external load capacitance $C_L = 30pF$.

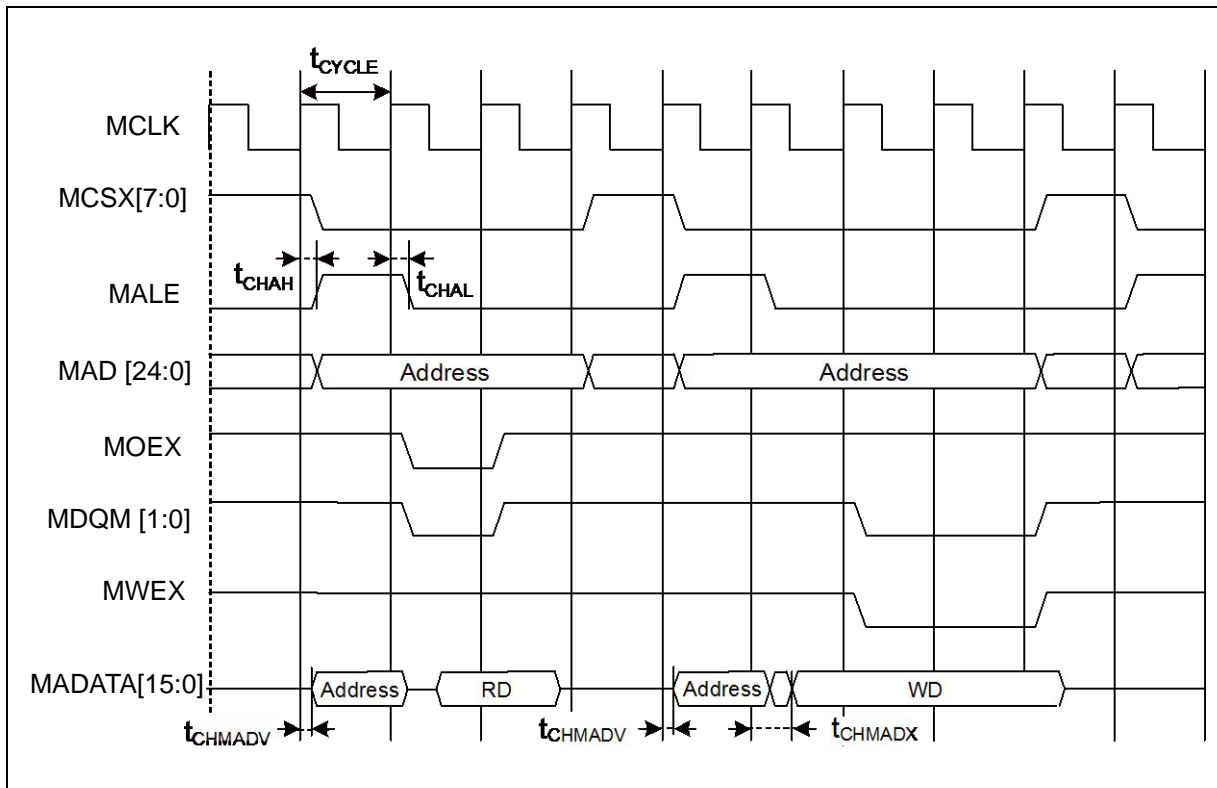

• External Ready Input Timing

($V_{CC} = 1.65V$ to $3.6V$, $V_{SS} = 0V$, $T_a = -40^{\circ}C$ to $+85^{\circ}C$)

Parameter	Symbol	Pin name	Conditions	Value		Unit	Remarks
				Min	Max		
MCLK \uparrow MRDY input setup time	t_{RDYI}	MCLK, MRDY	$V_{CC} \geq 2.7V$	23	-	ns	
			$V_{CC} < 2.7V$	37			

When RDY is input

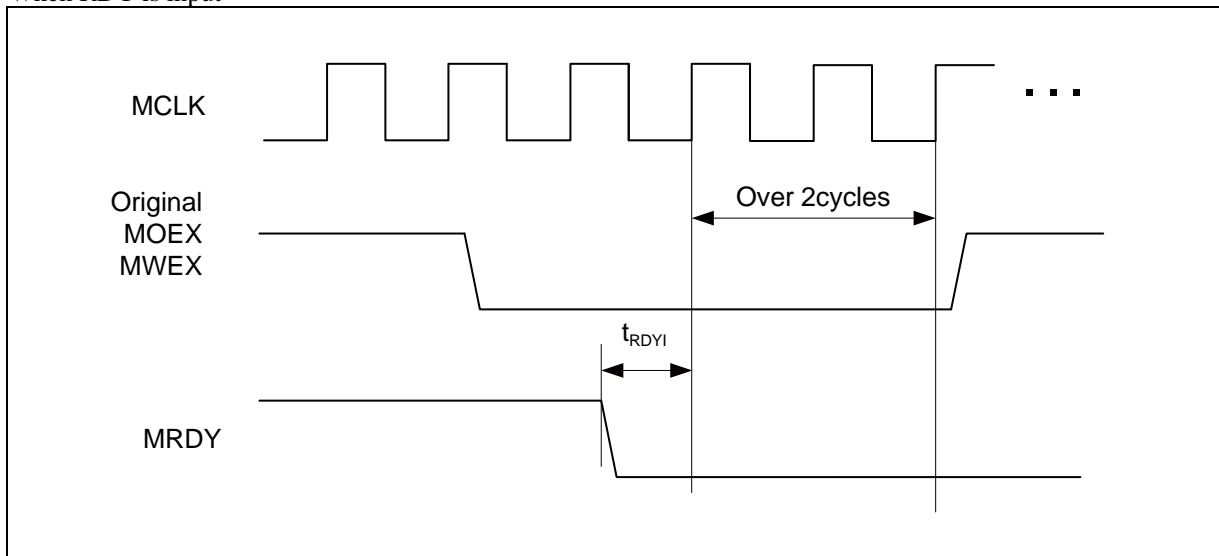

When RDY is released

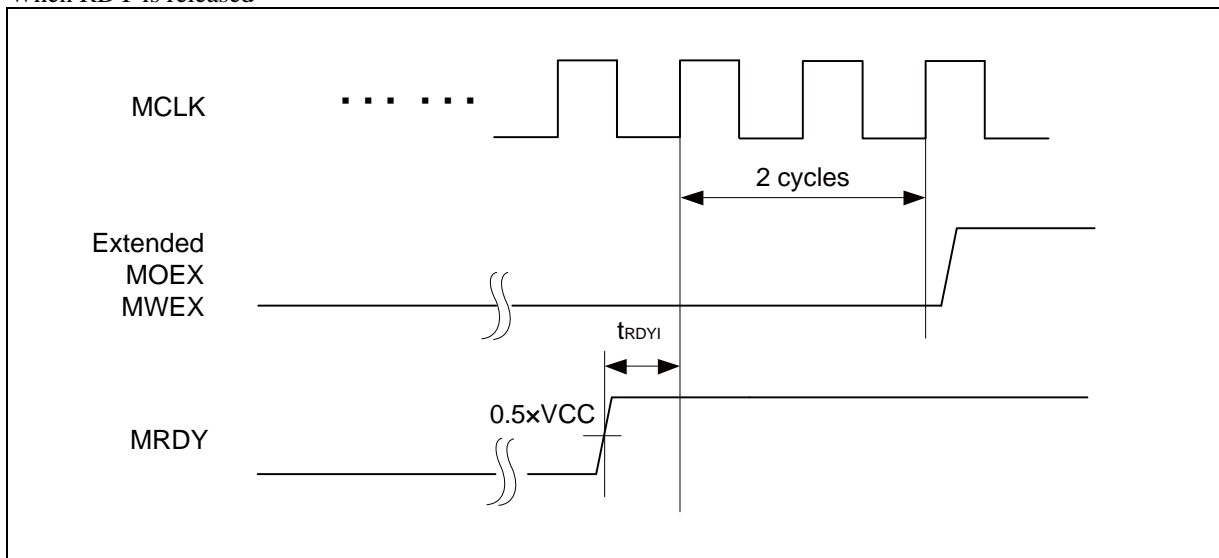

(8) Base Timer Input Timing

- Timer input timing

($V_{CC} = 1.65V$ to $3.6V$, $V_{SS} = 0V$, $T_a = -40^{\circ}C$ to $+85^{\circ}C$)

Parameter	Symbol	Pin name	Conditions	Value		Unit	Remarks
				Min	Max		
Input pulse width	t_{TIWH} , t_{TIWL}	TIOAn/TIOBn (when using as ECK, TIN)	-	$2t_{CYCP}$	-	ns	

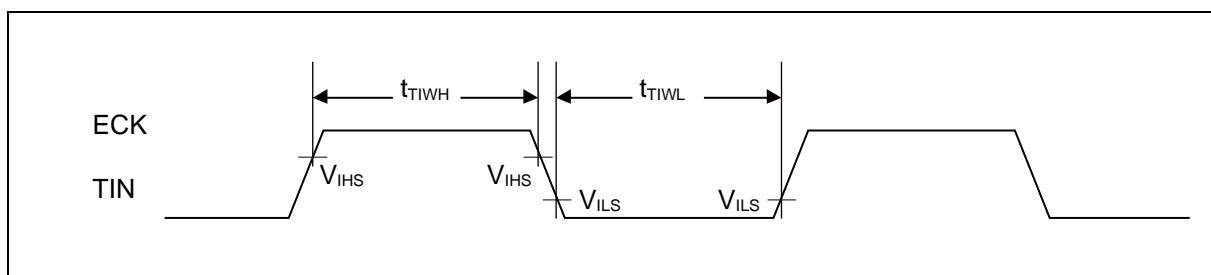

- Trigger input timing

($V_{CC} = 1.65V$ to $3.6V$, $V_{SS} = 0V$, $T_a = -40^{\circ}C$ to $+85^{\circ}C$)

Parameter	Symbol	Pin name	Conditions	Value		Unit	Remarks
				Min	Max		
Input pulse width	t_{TRGH} , t_{TRGL}	TIOAn/TIOBn (when using as TGIN)	-	$2t_{CYCP}$	-	ns	

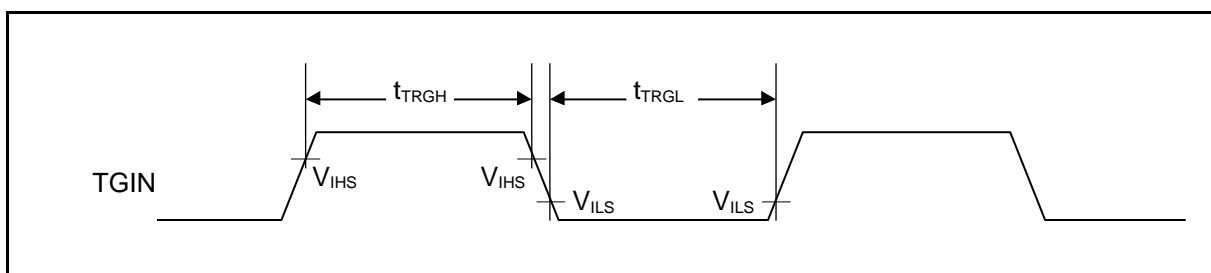

Note: t_{CYCP} indicates the APB bus clock cycle time.

About the APB bus number which the Base Timer is connected to, see "■BLOCK DIAGRAM" in this data sheet.

(9) CSIO Timing

- Synchronous serial (SPI = 0, SCINV = 0)

($V_{CC} = 1.65V$ to $3.6V$, $V_{SS} = 0V$, $T_a = -40^{\circ}C$ to $+85^{\circ}C$)

Parameter	Symbol	Pin name	Conditions	$V_{CC} < 2.7V$		$V_{CC} \geq 2.7V$		Unit
				Min	Max	Min	Max	
Serial clock cycle time	t_{SCYC}	SCK _X	Internal shift clock operation	$4t_{CYCP}$	-	$4t_{CYCP}$	-	ns
SCK ↓ → SOT delay time	t_{SLOVI}	SCK _X , SOT _X		- 30	+ 30	- 20	+ 20	ns
SIN → SCK ↑ setup time	t_{IVSHI}	SCK _X , SIN _X		50	-	36	-	ns
SCK ↑ → SIN hold time	t_{SHIXI}	SCK _X , SIN _X		0	-	0	-	ns
Serial clock "L" pulse width	t_{SLSH}	SCK _X	External shift clock operation	$2t_{CYCP} - 10$	-	$2t_{CYCP} - 10$	-	ns
Serial clock "H" pulse width	t_{SHSL}	SCK _X		$t_{CYCP} + 10$	-	$t_{CYCP} + 10$	-	ns
SCK ↓ → SOT delay time	t_{SLOVE}	SCK _X , SOT _X		-	50	-	33	ns
SIN → SCK ↑ setup time	t_{IVSHE}	SCK _X , SIN _X		10	-	10	-	ns
SCK ↑ → SIN hold time	t_{SHIXE}	SCK _X , SIN _X		20	-	20	-	ns
SCK falling time	tF	SCK _X		-	5	-	5	ns
SCK rising time	tR	SCK _X		-	5	-	5	ns

- Notes:
- The above characteristics apply to CLK synchronous mode.
 - t_{CYCP} indicates the APB bus clock cycle time.
About the APB bus number which Multi-function serial is connected to, see "■BLOCK DIAGRAM" in this data sheet.
 - These characteristics only guarantee the same relocate port number.
For example, the combination of SCLK_{x_0} and SOT_{x_1} is not guaranteed.
 - When the external load capacitance $C_L = 30pF$.

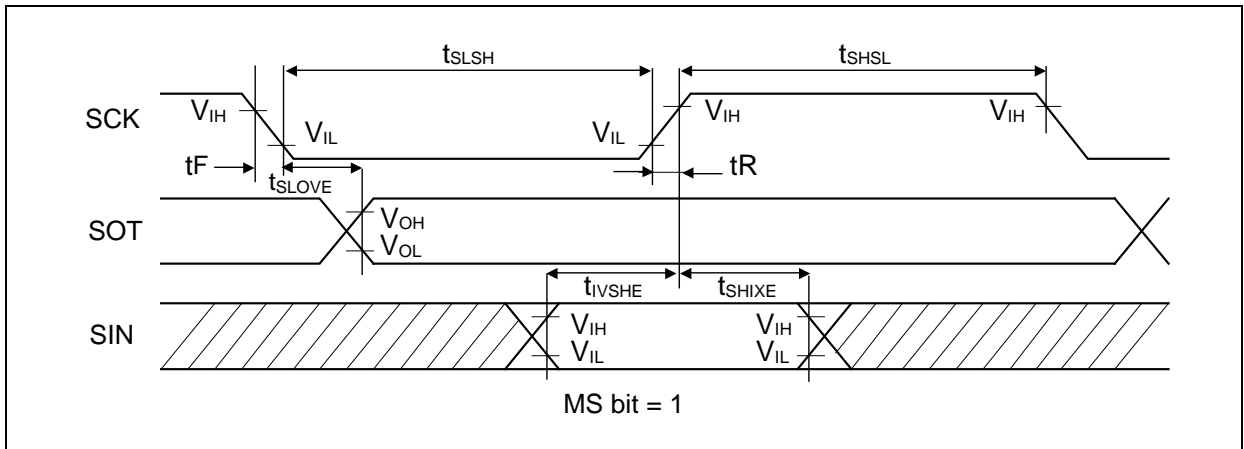
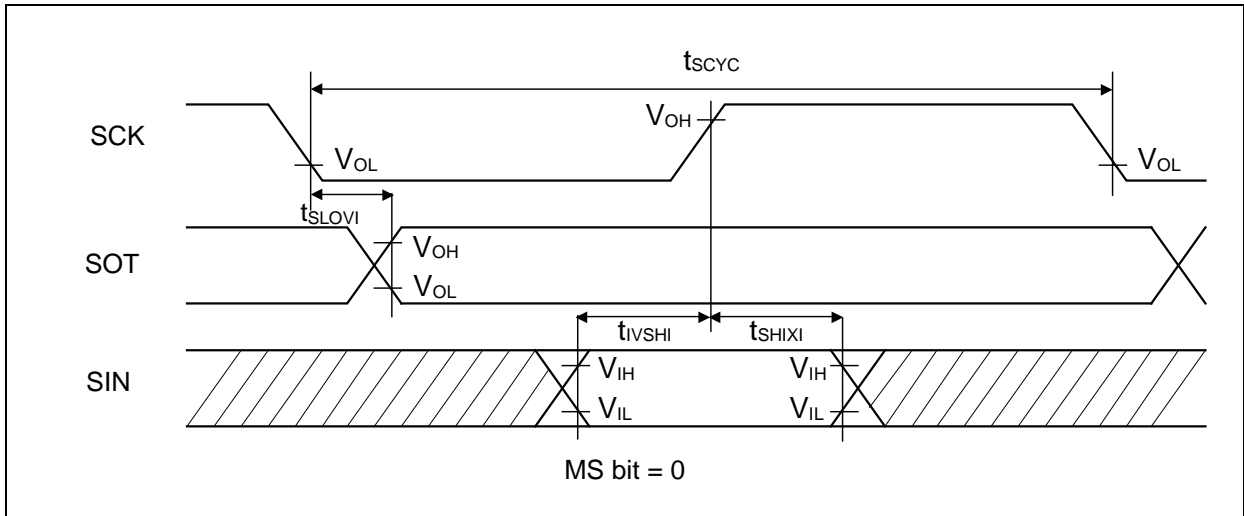

- Synchronous serial (SPI = 0, SCINV = 1)

($V_{CC} = 1.65V$ to $3.6V$, $V_{SS} = 0V$, $T_a = -40^{\circ}C$ to $+85^{\circ}C$)

Parameter	Symbol	Pin name	Conditions	$V_{CC} < 2.7V$		$V_{CC} \geq 2.7V$		Unit
				Min	Max	Min	Max	
Serial clock cycle time	t_{SCYC}	SCK _x	Internal shift clock operation	$4t_{CYCP}$	-	$4t_{CYCP}$	-	ns
SCK ↑ → SOT delay time	t_{SHOVI}	SCK _x , SOT _x		- 30	+ 30	- 20	+ 20	ns
SIN → SCK ↓ setup time	t_{IVSLI}	SCK _x , SIN _x		50	-	36	-	ns
SCK ↓ → SIN hold time	t_{SLIXI}	SCK _x , SIN _x		0	-	0	-	ns
Serial clock "L" pulse width	t_{SLSH}	SCK _x	External shift clock operation	$2t_{CYCP} - 10$	-	$2t_{CYCP} - 10$	-	ns
Serial clock "H" pulse width	t_{SHSL}	SCK _x		$t_{CYCP} + 10$	-	$t_{CYCP} + 10$	-	ns
SCK ↑ → SOT delay time	t_{SHOVE}	SCK _x , SOT _x		-	50	-	33	ns
SIN → SCK ↓ setup time	t_{IVSLE}	SCK _x , SIN _x		10	-	10	-	ns
SCK ↓ → SIN hold time	t_{SLIXE}	SCK _x , SIN _x		20	-	20	-	ns
SCK falling time	tF	SCK _x		-	5	-	5	ns
SCK rising time	tR	SCK _x		-	5	-	5	ns

- Notes:
- The above characteristics apply to CLK synchronous mode.
 - t_{CYCP} indicates the APB bus clock cycle time.
About the APB bus number which Multi-function serial is connected to, see "■BLOCK DIAGRAM" in this data sheet.
 - These characteristics only guarantee the same relocate port number.
For example, the combination of SCLK_{x_0} and SOT_{x_1} is not guaranteed.
 - When the external load capacitance $C_L = 30pF$.

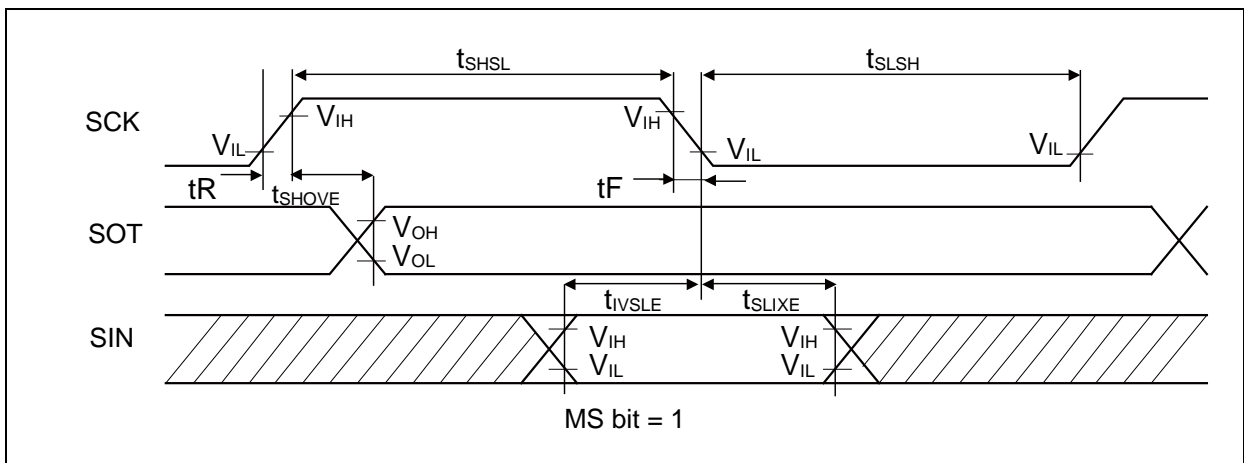
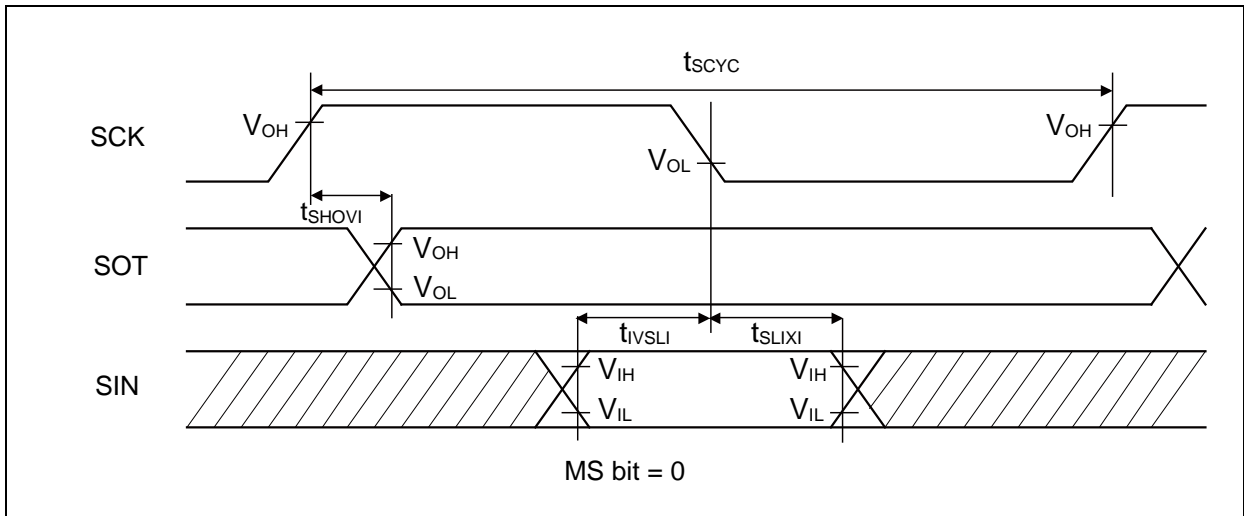

- Synchronous serial (SPI = 1, SCINV = 0)

($V_{CC} = 1.65V$ to $3.6V$, $V_{SS} = 0V$, $T_a = -40^{\circ}C$ to $+85^{\circ}C$)

Parameter	Symbol	Pin name	Conditions	$V_{CC} < 2.7V$		$V_{CC} \geq 2.7V$		Unit
				Min	Max	Min	Max	
Serial clock cycle time	t_{SCYC}	SCK _X	Internal shift clock operation	$4t_{CYCP}$	-	$4t_{CYCP}$	-	ns
SCK ↑ → SOT delay time	t_{SHOVI}	SCK _X , SOT _X		- 30	+ 30	- 20	+ 20	ns
SIN → SCK ↓ setup time	t_{IVSLI}	SCK _X , SIN _X		50	-	36	-	ns
SCK ↓ → SIN hold time	t_{SLIXI}	SCK _X , SIN _X		0	-	0	-	ns
SOT → SCK ↓ delay time	t_{SOVLI}	SCK _X , SOT _X		$2t_{CYCP} - 34$	-	$2t_{CYCP} - 34$	-	ns
Serial clock "L" pulse width	t_{SLSH}	SCK _X	External shift clock operation	$2t_{CYCP} - 10$	-	$2t_{CYCP} - 10$	-	ns
Serial clock "H" pulse width	t_{SHSL}	SCK _X		$t_{CYCP} + 10$	-	$t_{CYCP} + 10$	-	ns
SCK ↑ → SOT delay time	t_{SHOVE}	SCK _X , SOT _X		-	50	-	33	ns
SIN → SCK ↓ setup time	t_{IVSLE}	SCK _X , SIN _X		10	-	10	-	ns
SCK ↓ → SIN hold time	t_{SLIXE}	SCK _X , SIN _X		20	-	20	-	ns
SCK falling time	tF	SCK _X		-	5	-	5	ns
SCK rising time	tR	SCK _X		-	5	-	5	ns

- Notes:
- The above characteristics apply to CLK synchronous mode.
 - t_{CYCP} indicates the APB bus clock cycle time.
About the APB bus number which Multi-function serial is connected to, see "■BLOCK DIAGRAM" in this data sheet.
 - These characteristics only guarantee the same relocate port number.
For example, the combination of SCLK_{x_0} and SOT_{x_1} is not guaranteed.
 - When the external load capacitance $C_L = 30pF$.

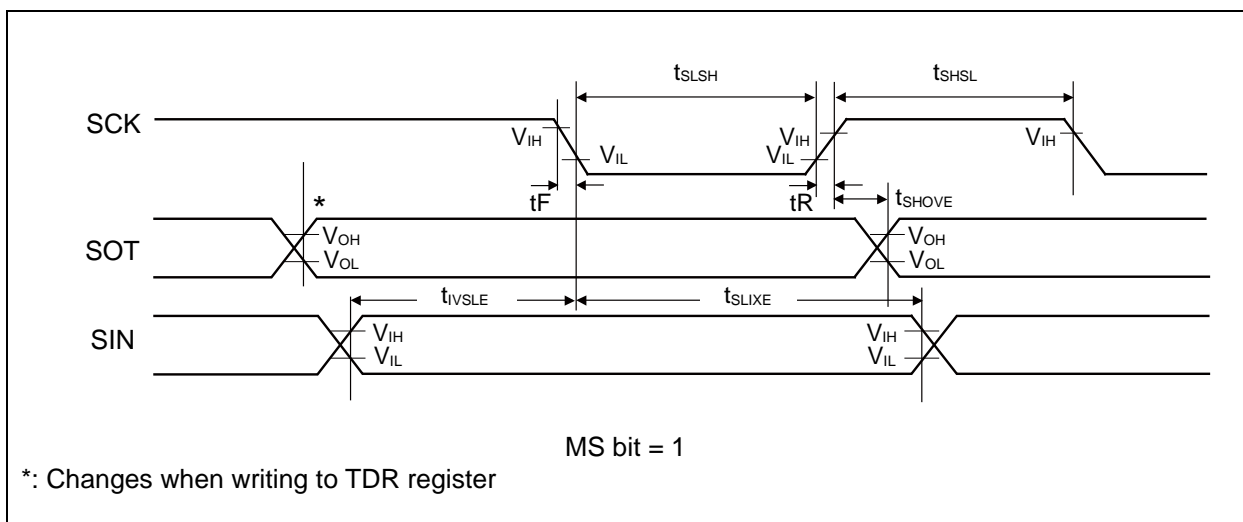
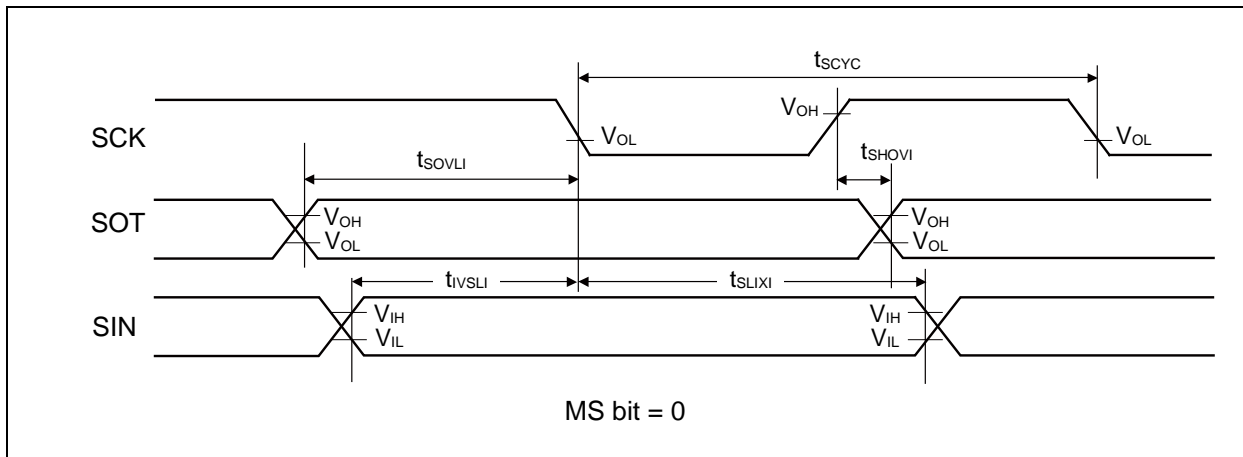

- Synchronous serial (SPI = 1, SCINV = 1)

($V_{CC} = 1.65V$ to $3.6V$, $V_{SS} = 0V$, $T_a = -40^{\circ}C$ to $+85^{\circ}C$)

Parameter	Symbol	Pin name	Conditions	$V_{CC} < 2.7V$		$V_{CC} \geq 2.7V$		Unit
				Min	Max	Min	Max	
Serial clock cycle time	t_{SCYC}	SCK _X	Internal shift clock operation	$4t_{CYCP}$	-	$4t_{CYCP}$	-	ns
SCK ↓ → SOT delay time	t_{SLOVI}	SCK _X , SOT _X		- 30	+ 30	- 20	+ 20	ns
SIN → SCK ↑ setup time	t_{IVSHI}	SCK _X , SIN _X		50	-	36	-	ns
SCK ↑ → SIN hold time	t_{SHIXI}	SCK _X , SIN _X		0	-	0	-	ns
SOT → SCK ↑ delay time	t_{SOVHI}	SCK _X , SOT _X		$2t_{CYCP} - 34$	-	$2t_{CYCP} - 34$	-	ns
Serial clock "L" pulse width	t_{SLSH}	SCK _X	External shift clock operation	$2t_{CYCP} - 10$	-	$2t_{CYCP} - 10$	-	ns
Serial clock "H" pulse width	t_{SHSL}	SCK _X		$t_{CYCP} + 10$	-	$t_{CYCP} + 10$	-	ns
SCK ↓ → SOT delay time	t_{SLOVE}	SCK _X , SOT _X		-	50	-	33	ns
SIN → SCK ↑ setup time	t_{IVSHE}	SCK _X , SIN _X		10	-	10	-	ns
SCK ↑ → SIN hold time	t_{SHIXE}	SCK _X , SIN _X		20	-	20	-	ns
SCK falling time	tF	SCK _X		-	5	-	5	ns
SCK rising time	tR	SCK _X		-	5	-	5	ns

- Notes:
- The above characteristics apply to CLK synchronous mode.
 - t_{CYCP} indicates the APB bus clock cycle time.
About the APB bus number which Multi-function serial is connected to, see "■BLOCK DIAGRAM" in this data sheet.
 - These characteristics only guarantee the same relocate port number.
For example, the combination of SCLK_{X_0} and SOT_{X_1} is not guaranteed.
 - When the external load capacitance $C_L = 30pF$.

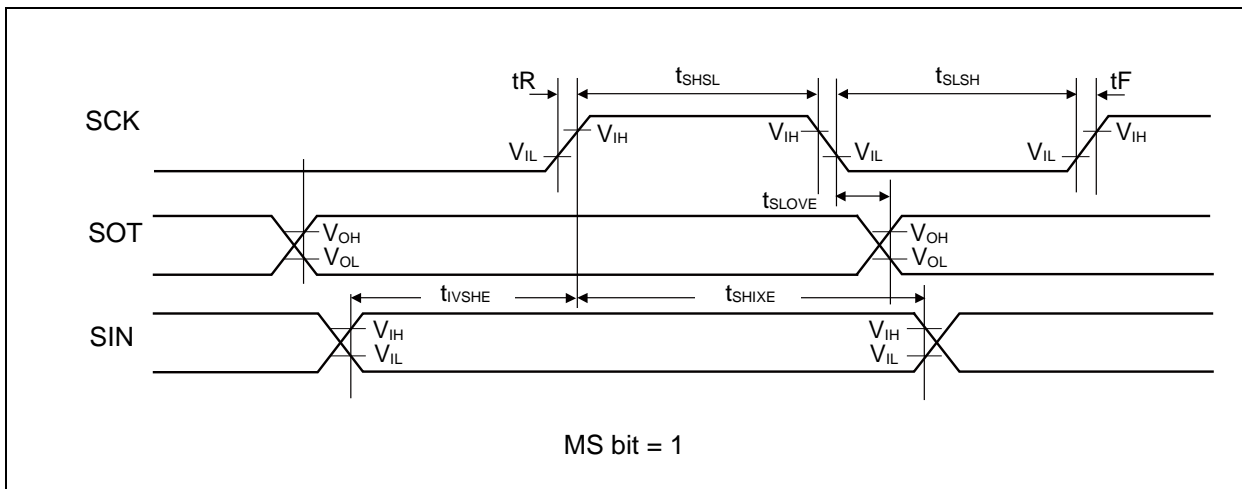
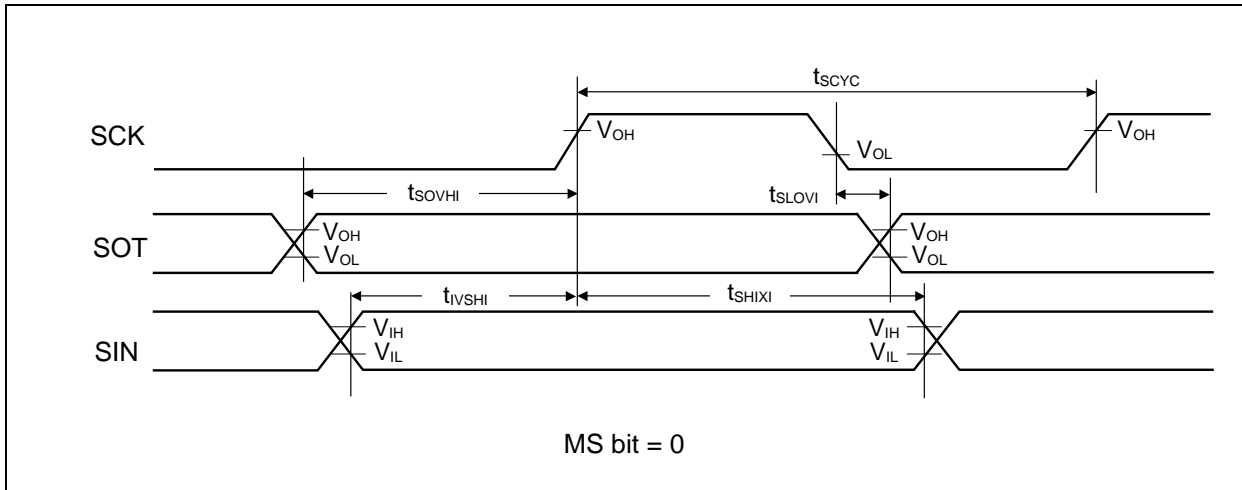

- External clock (EXT = 1) : asynchronous only

($V_{CC} = 1.65V$ to $3.6V$, $V_{SS} = 0V$, $T_a = -40^{\circ}C$ to $+85^{\circ}C$)

Parameter	Symbol	Conditions	Value		Unit	Remarks
			Min	Max		
Serial clock "L" pulse width	t_{SLSH}	$C_L = 30pF$	$t_{CYCP} + 10$	-	ns	
Serial clock "H" pulse width	t_{SHSL}		$t_{CYCP} + 10$	-	ns	
SCK falling time	t_F		-	5	ns	
SCK rising time	t_R		-	5	ns	

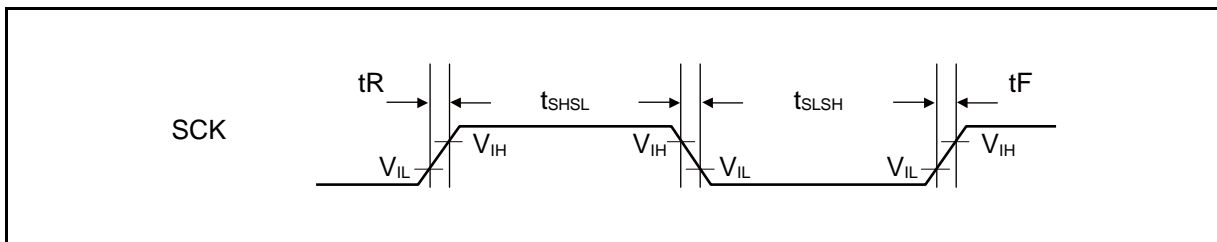

(10) External Input Timing

($V_{CC} = 1.65V$ to $3.6V$, $V_{SS} = 0V$, $T_a = -40^{\circ}C$ to $+85^{\circ}C$)

Parameter	Symbol	Pin name	Conditions	Value		Unit	Remarks
				Min	Max		
Input pulse width	t_{INH} , t_{INL}	ADTG	-	$2t_{CYCP}^{*1}$	-	ns	A/D converter trigger input
		INT00 to INT15, NMIX	-	$2t_{CYCP} + 100^{*1}$	-	ns	External interrupt, NMI
				500 ^{*2}	-	ns	
		WKUPx	-	600 ^{*3}	-	ns	Deep standby wake up

*1 : t_{CYCP} indicates the APB bus clock cycle time except stop when in stop mode, in timer mode.

About the APB bus number which the Multi-function Timer is connected to, see "■BLOCK DIAGRAM" in this data sheet.

*2 : When in stop mode, in timer mode.

*3 : When in deep standby RTC mode, in deep standby stop mode.

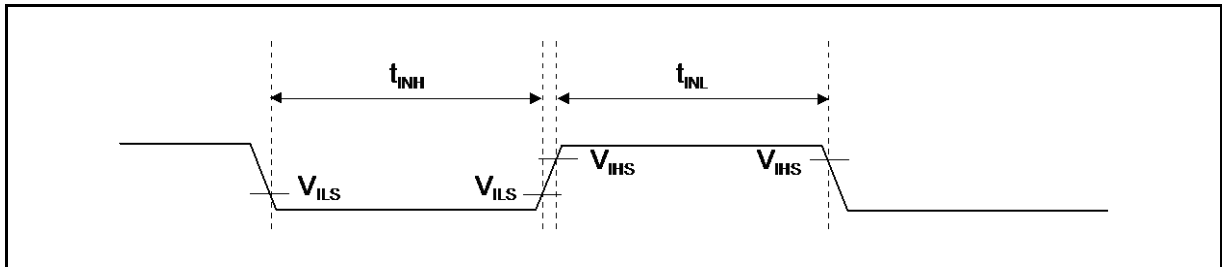

(11) I²C Timing

(V_{CC} = 1.65V to 3.6V, V_{SS} = 0V, Ta = - 40°C to + 85°C)

Parameter	Symbol	Conditions	Typical mode		High-speed mode		Unit	Remarks
			Min	Max	Min	Max		
SCL clock frequency	F _{SCL}		0	100	0	400	kHz	
(Repeated) START condition hold time SDA ↓ → SCL ↓	t _{HDSTA}	C _L = 30pF, R = (V _p /I _{OL})* ¹	4.0	-	0.6	-	μs	
SCL clock "L" width	t _{LOW}		4.7	-	1.3	-	μs	
SCL clock "H" width	t _{HIGH}		4.0	-	0.6	-	μs	
(Repeated) START condition setup time SCL ↑ → SDA ↓	t _{SUSTA}		4.7	-	0.6	-	μs	
Data hold time SCL ↓ → SDA ↓ ↑	t _{HDDAT}		0	3.45* ²	0	0.9* ³	μs	
Data setup time SDA ↓ ↑ → SCL ↑	t _{SUDAT}		250	-	100	-	ns	
STOP condition setup time SCL ↑ → SDA ↑	t _{SUSTO}		4.0	-	0.6	-	μs	
Bus free time between "STOP condition" and "START condition"	t _{BUF}		4.7	-	1.3	-	μs	
Noise filter	t _{SP}		-	2 t _{CYCP} * ⁴	-	2 t _{CYCP} * ⁴	-	ns

*1: R and C represent the pull-up resistor and load capacitance of the SCL and SDA lines, respectively.

V_p indicates the power supply voltage of the pull-up resistor and I_{OL} indicates V_{OL} guaranteed current.

*2: The maximum t_{HDDAT} must satisfy that it does not extend at least "L" period (t_{LOW}) of device's SCL signal.

*3: A high-speed mode I²C bus device can be used on a standard mode I²C bus system as long as the device satisfies the requirement of "t_{SUDAT} ≥ 250 ns".

*4: t_{CYCP} is the APB bus clock cycle time.

About the APB bus number that I²C is connected to, see "■BLOCK DIAGRAM" in this data sheet.

To use standard mode, set the APB bus clock at 2MHz or more.

To use high-speed mode, set the APB bus clock at 8MHz or more.

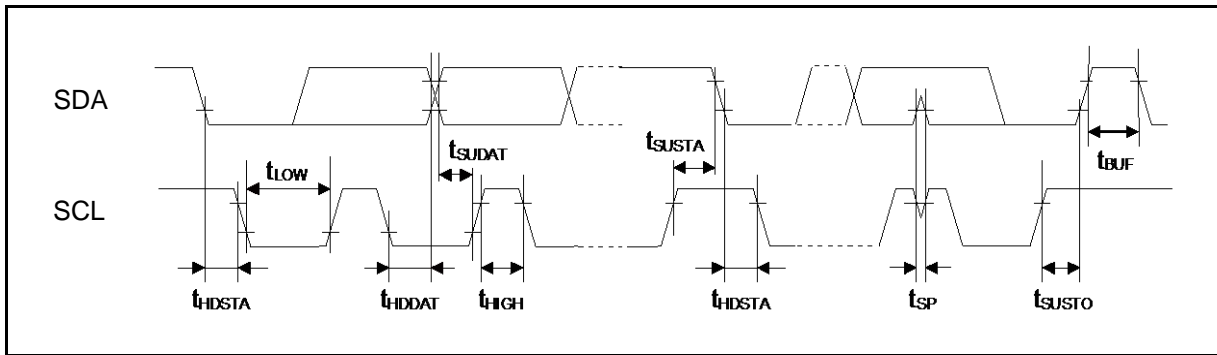

(12) ETM Timing

($V_{CC} = 1.65V$ to $3.6V$, $V_{SS} = 0V$, $T_a = -40^{\circ}C$ to $+85^{\circ}C$)

Parameter	Symbol	Pin name	Conditions	Value		Unit	Remarks
				Min	Max		
Data hold	t_{ETMH}	TRACECLK, TRACED[3:0]	$V_{CC} \geq 2.7V$	2	11	ns	
			$V_{CC} < 2.7V$	2	15		
TRACECLK frequency	$1/t_{TRACE}$	TRACECLK	$V_{CC} \geq 2.7V$	-	40	MHz	
			$V_{CC} < 2.7V$	-	20	MHz	
TRACECLK cycle time	t_{TRACE}		$V_{CC} \geq 2.7V$	25	-	ns	
			$V_{CC} < 2.7V$	50	-	ns	

Note: When the external load capacitance $C_L = 30pF$.

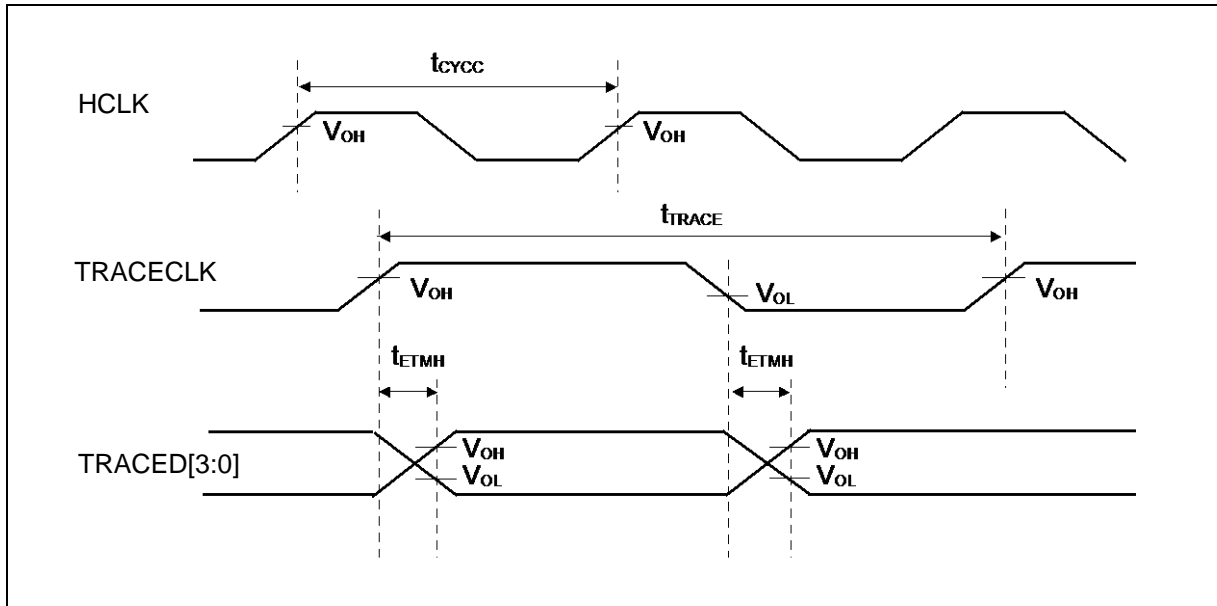

(13) JTAG Timing

($V_{CC} = 1.65V$ to $3.6V$, $V_{SS} = 0V$, $T_a = -40^{\circ}C$ to $+85^{\circ}C$)

Parameter	Symbol	Pin name	Conditions	Value		Unit	Remarks
				Min	Max		
TMS, TDI setup time	t_{JTAGS}	TCK, TMS, TDI	$V_{CC} \geq 2.7V$	15	-	ns	
			$V_{CC} < 2.7V$				
TMS, TDI hold time	t_{JTAGH}	TCK, TMS, TDI	$V_{CC} \geq 2.7V$	15	-	ns	
			$V_{CC} < 2.7V$				
TDO delay time	t_{JTAGD}	TCK, TDO	$V_{CC} \geq 2.7V$	-	25	ns	
			$V_{CC} < 2.7V$	-	45		

Note: When the external load capacitance $C_L = 30pF$.

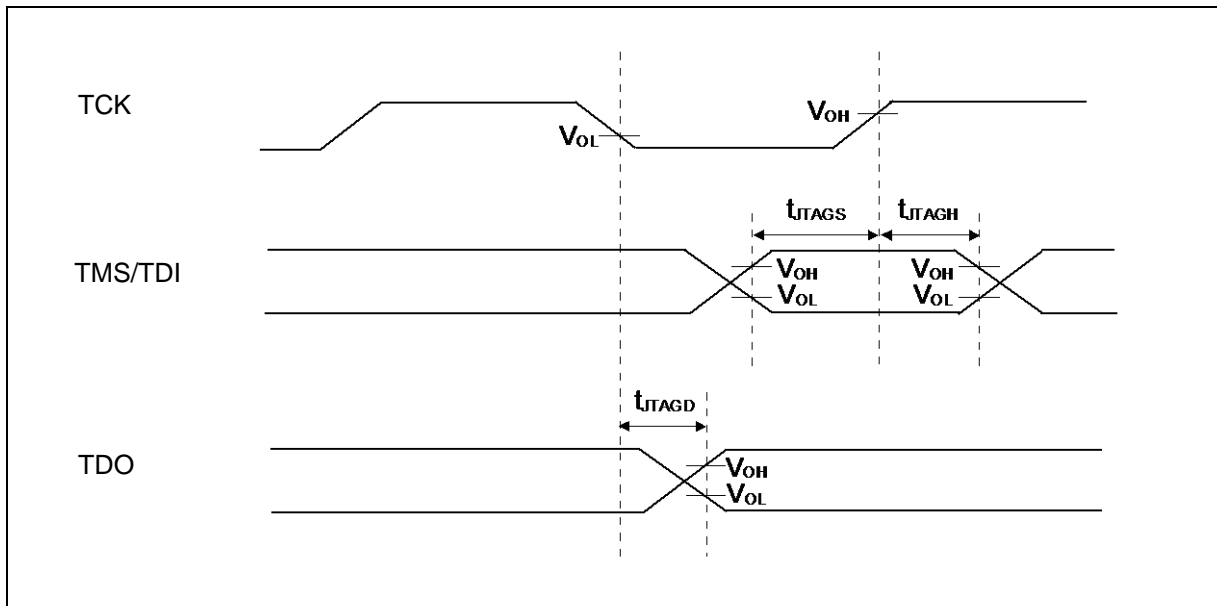

5. 12-bit A/D Converter

• Electrical Characteristics for the A/D Converter

($V_{CC} = AV_{CC} = 1.65V$ to $3.6V$, $V_{SS} = AV_{SS} = 0V$, $T_a = -40^{\circ}C$ to $+85^{\circ}C$)

Parameter	Symbol	Pin name	Value			Unit	Remarks
			Min	Typ	Max		
Resolution	-	-	-	-	12	bit	
Integral Nonlinearity	-	-	- 4.5	-	+ 4.5	LSB	
Differential Nonlinearity	-	-	- 2.5	-	+ 2.5	LSB	
Zero transition voltage	V_{ZT}	AN00 to AN23	- 15	-	+ 15	mV	
Full-scale transition voltage	V_{FST}	AN00 to AN23	AVRH - 15	-	AVRH + 15	mV	
Conversion time	-	-	2.0* ¹	-	-	μs	$AV_{CC} \geq 2.7V$
Sampling time	T_s	-	*2	-	10	μs	$AV_{CC} \geq 2.7V$
			*2	-			$1.8V \leq AV_{CC} < 2.7V$
			*2	-			$1.65V \leq AV_{CC} < 1.8V$
Compare clock cycle* ³	T_{cck}	-	100	-	1000	ns	$AV_{CC} \geq 2.7V$
			200				$1.8V \leq AV_{CC} < 2.7V$
			500				$1.65V \leq AV_{CC} < 1.8V$
State transition time to operation permission	T_{stt}	-	1	-	-	μs	
Power supply current (analog + digital)	-	AVCC	-	0.27	0.42	mA	A/D 1unit operation
			-	0.03	10	μA	When A/D stops
Reference power supply current (between AVRH and AVSS)	-	AVRH	-	0.72	1.29	mA	A/D 1unit operation AVRH=3.6V
			-	0.02	2.6	μA	When A/D stops
Analog input capacity	C_{AIN}	-	-	-	9.4	pF	
Analog input resistor	R_{AIN}	-	-	-	2.2	k Ω	$AV_{CC} \geq 2.7V$
					5.5		$1.8V \leq AV_{CC} < 2.7V$
					10.5		$1.65V \leq AV_{CC} < 1.8V$
Interchannel disparity	-	-	-	-	4	LSB	
Analog port input current	-	AN00 to AN23	-	-	5	μA	
Analog input voltage	-	AN00 to AN23	AV_{SS}	-	AVRH	V	
Reference voltage	-	AVRH	2.7	-	AV_{CC}	V	$AV_{CC} \geq 2.7V$
			AV_{CC}				$AV_{CC} < 2.7V$

*1: The conversion time is the value of sampling time (T_s) + compare time (T_c).

The condition of the minimum conversion time is when the value of sampling time: 600ns, the value of compare time: 1400ns ($AV_{CC} \geq 2.7V$).

Ensure that it satisfies the value of the sampling time (T_s) and compare clock cycle (T_{cck}).

For setting*⁴ of the sampling time and compare clock cycle, see "Chapter: A/D Converter" in "FM3 Family PERIPHERAL MANUAL Analog Macro Part".

The A/D Converter register is set at the peripheral clock timing. The sampling clock and compare clock are set at Base clock (HCLK).

*2: A necessary sampling time changes by external impedance.

Ensure that it sets the sampling time to satisfy (Equation 1).

*3: The compare time (T_c) is the value of (Equation 2).

*4: The register setting of the A/D Converter is set at the timing of the APB bus clock.

The sampling clock and compare clock are set in base clock (HCLK).

About the APB bus number which the A/D Converter is connected to, see "■BLOCK DIAGRAM" in this data sheet.

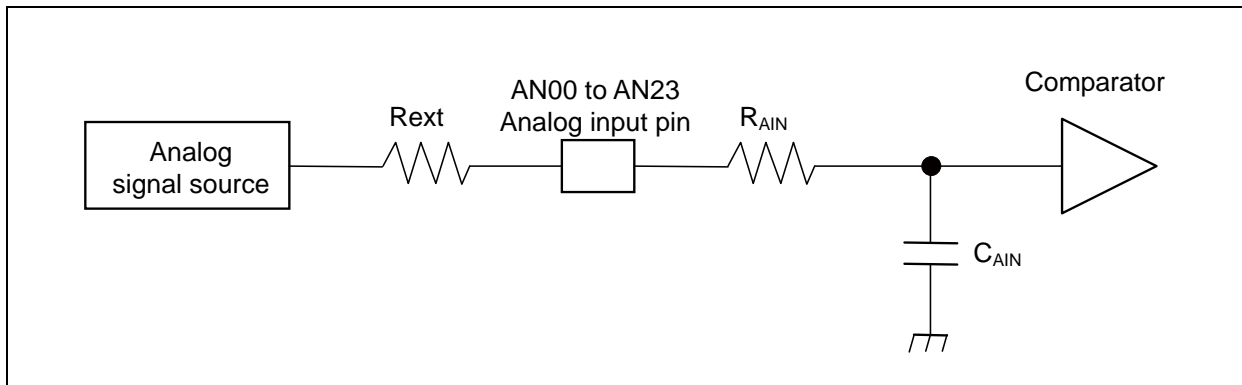

$$\text{(Equation 1) } T_s \geq (R_{AIN} + R_{ext}) \times C_{AIN} \times 9$$

T_s : Sampling time[ns]

R_{AIN} : input resistor of A/D[k Ω] = 2.2k Ω at 2.7V \leq AV_{CC} \leq 3.6V

input resistor of A/D[k Ω] = 5.5k Ω at 1.8V \leq AV_{CC} \leq 2.7V

input resistor of A/D[k Ω] = 10.5k Ω at 1.65V \leq AV_{CC} \leq 1.8V

C_{AIN} : input capacity of A/D[pF] = 9.4pF at 1.65V \leq AV_{CC} \leq 3.6V

R_{ext} : Output impedance of external circuit[k Ω]

$$\text{(Equation 2) } T_c = T_{cck} \times 14$$

T_c : Compare time

T_{cck} : Compare clock cycle

• Definition of 12-bit A/D Converter Terms

- Resolution : Analog variation that is recognized by an A/D converter.
- Integral Nonlinearity : Deviation of the line between the zero-transition point (0b000000000000 ←→ 0b000000000001) and the full-scale transition point (0b111111111110 ←→ 0b111111111111) from the actual conversion characteristics.
- Differential Nonlinearity : Deviation from the ideal value of the input voltage that is required to change the output code by 1 LSB.

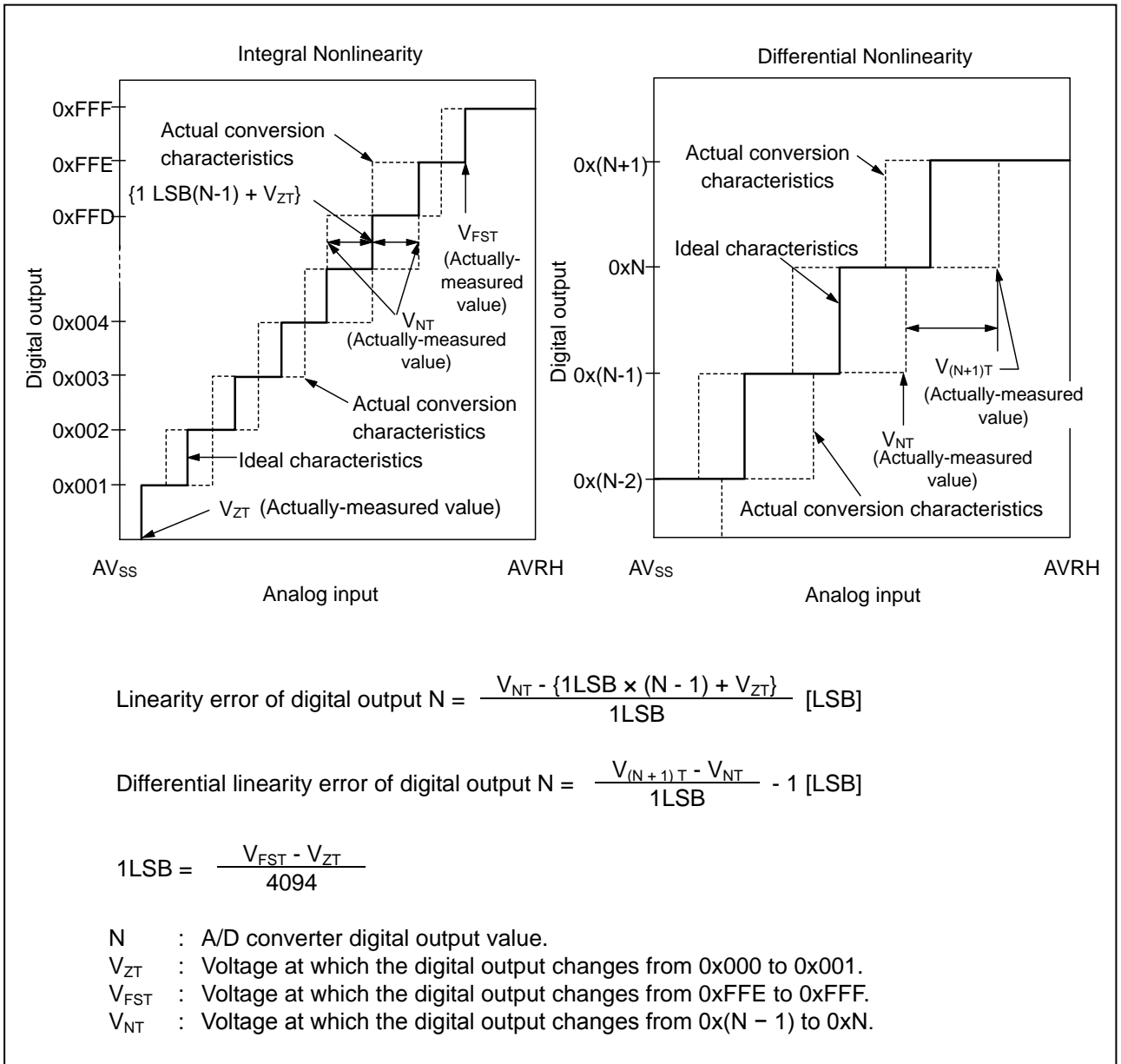

6. Low-Voltage Detection Characteristics

(1) Low-Voltage Detection Reset

(Ta = - 40°C to + 85°C)

Parameter	Symbol	Conditions	Value			Unit	Remarks
			Min	Typ	Max		
Detected voltage	VDL	SVHR*1 = 00000	1.38	1.50	1.60	V	When voltage drops
Released voltage	VDH		1.43	1.55	1.65	V	When voltage rises
Detected voltage	VDL	SVHR*1 = 00001	1.43	1.55	1.65	V	When voltage drops
Released voltage	VDH		Same as SVHR = 00000 value			V	When voltage rises
Detected voltage	VDL	SVHR*1 = 00010	1.47	1.60	1.73	V	When voltage drops
Released voltage	VDH		Same as SVHR = 00000 value			V	When voltage rises
Detected voltage	VDL	SVHR*1 = 00011	1.52	1.65	1.78	V	When voltage drops
Released voltage	VDH		Same as SVHR = 00000 value			V	When voltage rises
Detected voltage	VDL	SVHR*1 = 00100	1.56	1.70	1.84	V	When voltage drops
Released voltage	VDH		Same as SVHR = 00000 value			V	When voltage rises
Detected voltage	VDL	SVHR*1 = 00101	1.61	1.75	1.89	V	When voltage drops
Released voltage	VDH		Same as SVHR = 00000 value			V	When voltage rises
Detected voltage	VDL	SVHR*1 = 00110	1.66	1.80	1.94	V	When voltage drops
Released voltage	VDH		Same as SVHR = 00000 value			V	When voltage rises
Detected voltage	VDL	SVHR*1 = 00111	1.70	1.85	2.00	V	When voltage drops
Released voltage	VDH		Same as SVHR = 00000 value			V	When voltage rises
Detected voltage	VDL	SVHR*1 = 01000	1.75	1.90	2.05	V	When voltage drops
Released voltage	VDH		Same as SVHR = 00000 value			V	When voltage rises
Detected voltage	VDL	SVHR*1 = 01001	1.79	1.95	2.11	V	When voltage drops
Released voltage	VDH		Same as SVHR = 00000 value			V	When voltage rises
Detected voltage	VDL	SVHR*1 = 01010	1.84	2.00	2.16	V	When voltage drops
Released voltage	VDH		Same as SVHR = 00000 value			V	When voltage rises
Detected voltage	VDL	SVHR*1 = 01011	1.89	2.05	2.21	V	When voltage drops
Released voltage	VDH		Same as SVHR = 00000 value			V	When voltage rises
Detected voltage	VDL	SVHR*1 = 01100	2.30	2.50	2.70	V	When voltage drops
Released voltage	VDH		Same as SVHR = 00000 value			V	When voltage rises
Detected voltage	VDL	SVHR*1 = 01101	2.39	2.60	2.81	V	When voltage drops
Released voltage	VDH		Same as SVHR = 00000 value			V	When voltage rises
Detected voltage	VDL	SVHR*1 = 01110	2.48	2.70	2.92	V	When voltage drops
Released voltage	VDH		Same as SVHR = 00000 value			V	When voltage rises
Detected voltage	VDL	SVHR*1 = 01111	2.58	2.80	3.02	V	When voltage drops
Released voltage	VDH		Same as SVHR = 00000 value			V	When voltage rises
Detected voltage	VDL	SVHR*1 = 10000	2.67	2.90	3.13	V	When voltage drops
Released voltage	VDH		Same as SVHR = 00000 value			V	When voltage rises
Detected voltage	VDL	SVHR*1 = 10001	2.76	3.00	3.24	V	When voltage drops
Released voltage	VDH		Same as SVHR = 00000 value			V	When voltage rises
Detected voltage	VDL	SVHR*1 = 10010	2.85	3.10	3.35	V	When voltage drops
Released voltage	VDH		Same as SVHR = 00000 value			V	When voltage rises
Detected voltage	VDL	SVHR*1 = 10011	2.94	3.20	3.46	V	When voltage drops
Released voltage	VDH		Same as SVHR = 00000 value			V	When voltage rises
LVD stabilization wait time	T _{LVDW}	-	-	-	5200 × t _{CYCP} *2	μs	
LVD detection delay time	T _{LVDL}	-	-	-	200	μs	

*1: The SVHR bit of Low-Voltage Detection Voltage Control Register (LVD_CTL) is initialized to "00000" by Low-Voltage Detection Reset.

*2: t_{CYCP} indicates the APB2 bus clock cycle time.

(2) Interrupt of Low-Voltage Detection

(Ta = - 40°C to + 85°C)

Parameter	Symbol	Conditions	Value			Unit	Remarks
			Min	Typ	Max		
Detected voltage	VDL	SVHI = 00100	1.56	1.70	1.84	V	When voltage drops
Released voltage	VDH		1.61	1.75	1.89	V	When voltage rises
Detected voltage	VDL	SVHI = 00101	1.61	1.75	1.89	V	When voltage drops
Released voltage	VDH		1.66	1.80	1.94	V	When voltage rises
Detected voltage	VDL	SVHI = 00110	1.66	1.80	1.94	V	When voltage drops
Released voltage	VDH		1.70	1.85	2.00	V	When voltage rises
Detected voltage	VDL	SVHI = 00111	1.70	1.85	2.00	V	When voltage drops
Released voltage	VDH		1.75	1.90	2.05	V	When voltage rises
Detected voltage	VDL	SVHI = 01000	1.75	1.90	2.05	V	When voltage drops
Released voltage	VDH		1.79	1.95	2.11	V	When voltage rises
Detected voltage	VDL	SVHI = 01001	1.79	1.95	2.11	V	When voltage drops
Released voltage	VDH		1.84	2.00	2.16	V	When voltage rises
Detected voltage	VDL	SVHI = 01010	1.84	2.00	2.16	V	When voltage drops
Released voltage	VDH		1.89	2.05	2.21	V	When voltage rises
Detected voltage	VDL	SVHI = 01011	1.89	2.05	2.21	V	When voltage drops
Released voltage	VDH		1.93	2.10	2.27	V	When voltage rises
Detected voltage	VDL	SVHI = 01100	2.30	2.50	2.70	V	When voltage drops
Released voltage	VDH		2.39	2.60	2.81	V	When voltage rises
Detected voltage	VDL	SVHI = 01101	2.39	2.60	2.81	V	When voltage drops
Released voltage	VDH		2.48	2.70	2.92	V	When voltage rises
Detected voltage	VDL	SVHI = 01110	2.48	2.70	2.92	V	When voltage drops
Released voltage	VDH		2.58	2.80	3.02	V	When voltage rises
Detected voltage	VDL	SVHI = 01111	2.58	2.80	3.02	V	When voltage drops
Released voltage	VDH		2.67	2.90	3.13	V	When voltage rises
Detected voltage	VDL	SVHI = 10000	2.67	2.90	3.13	V	When voltage drops
Released voltage	VDH		2.76	3.00	3.24	V	When voltage rises
Detected voltage	VDL	SVHI = 10001	2.76	3.00	3.24	V	When voltage drops
Released voltage	VDH		2.85	3.10	3.35	V	When voltage rises
Detected voltage	VDL	SVHI = 10010	2.85	3.10	3.35	V	When voltage drops
Released voltage	VDH		2.94	3.20	3.46	V	When voltage rises
Detected voltage	VDL	SVHI = 10011	2.94	3.20	3.46	V	When voltage drops
Released voltage	VDH		3.04	3.30	3.56	V	When voltage rises
LVD stabilization wait time	T _{LVDW}	-	-	-	5200 × t _{CYCP} *	μs	
LVD detection delay time	T _{LVDL}	-	-	-	200	μs	

*: t_{CYCP} indicates the APB2 bus clock cycle time.

7. Flash Memory Write/Erase Characteristics

(V_{CC} = 1.65V to 3.6V, Ta = - 40°C to + 85°C)

Parameter		Value			Unit	Remarks
		Min	Typ	Max		
Sector erase time	Large Sector	-	1.1	2.7	s	Includes write time prior to internal erase
	Small Sector		0.3	0.9		
Half word (16-bit) write time		-	30	528	μs	Not including system-level overhead time
Chip erase time		-	6.8	18	s	Includes write time prior to internal erase

Write cycles and data hold time

Erase/write cycles (cycle)	Data hold time (year)	Remarks
1,000	20*	
10,000	10*	

*: This value comes from the technology qualification (using Arrhenius equation to translate high temperature acceleration test result into average temperature value at + 85°C) .

■ ORDERING INFORMATION

Part number	Package
MB9AF141LAPMC1	Plastic • LQFP 64-pin (0.5mm pitch), (FPT-64P-M38)
MB9AF142LAPMC1	
MB9AF144LAPMC1	
MB9AF141LAPMC	Plastic • LQFP 64-pin (0.65mm pitch), (FPT-64P-M39)
MB9AF142LAPMC	
MB9AF144LAPMC	
MB9AF141LAQN	Plastic • QFN 64-pin (0.5mm pitch), (LCC-64P-M24)
MB9AF142LAQN	
MB9AF144LAQN	
MB9AF141MAPMC	Plastic • LQFP 80-pin (0.5mm pitch), (FPT-80P-M37)
MB9AF142MAPMC	
MB9AF144MAPMC	
MB9AF141MAPMC1	Plastic • LQFP 80-pin (0.65mm pitch), (FPT-80P-M40)
MB9AF142MAPMC1	
MB9AF144MAPMC1	
MB9AF141MABGL	Plastic • PFBGA 96-pin (0.5mm pitch), (BGA-96P-M07)
MB9AF142MABGL	
MB9AF144MABGL	
MB9AF141NAPMC	Plastic • LQFP 100-pin (0.5mm pitch), (FPT-100P-M23)
MB9AF142NAPMC	
MB9AF144NAPMC	
MB9AF141NAPQC	Plastic • QFP 100-pin (0.65mm pitch), (FPT-100P-M36)
MB9AF142NAPQC	
MB9AF144NAPQC	
MB9AF141NABGL	Plastic • PFBGA 112-pin (0.8mm pitch), (BGA-112P-M04)
MB9AF142NABGL	
MB9AF144NABGL	

■ PACKAGE DIMENSIONS

<p>100-pin plastic LQFP</p> <p>(FPT-100P-M23)</p>	Lead pitch	0.50 mm
	Package width × package length	14.00 mm × 14.00 mm
	Lead shape	Gullwing
	Lead bend direction	Normal bend
	Sealing method	Plastic mold
	Mounting height	1.70 mm MAX
	Weight	0.65 g

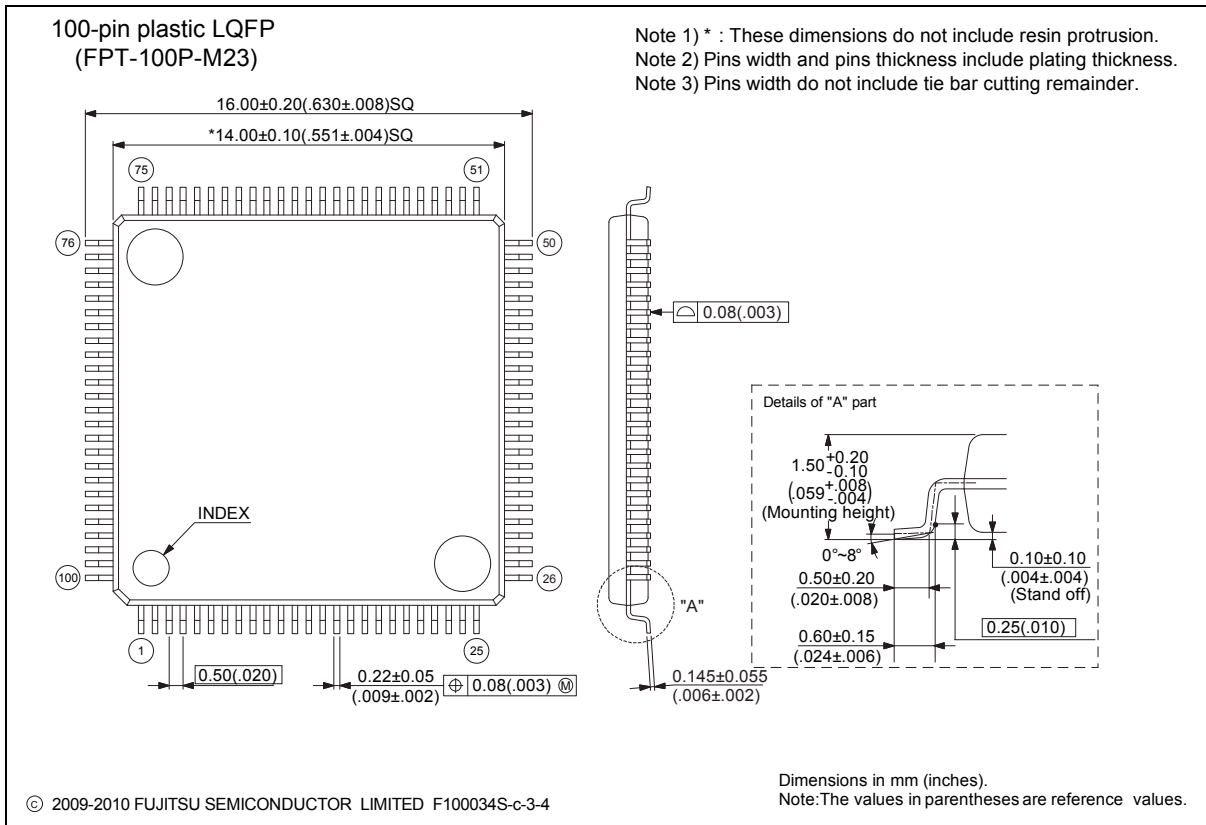

Please check the latest package dimension at the following URL.
<http://edevice.fujitsu.com/package/en-search/>

<p>100-pin plastic QFP</p> <p>(FPT-100P-M36)</p>	Lead pitch	0.65 mm
	Package width × package length	14.00 mm × 20.00 mm
	Lead shape	Gullwing
	Sealing method	Plastic mold
	Mounting height	3.35 mm MAX
	Code (Reference)	P-QFP100-14 × 20-0.65

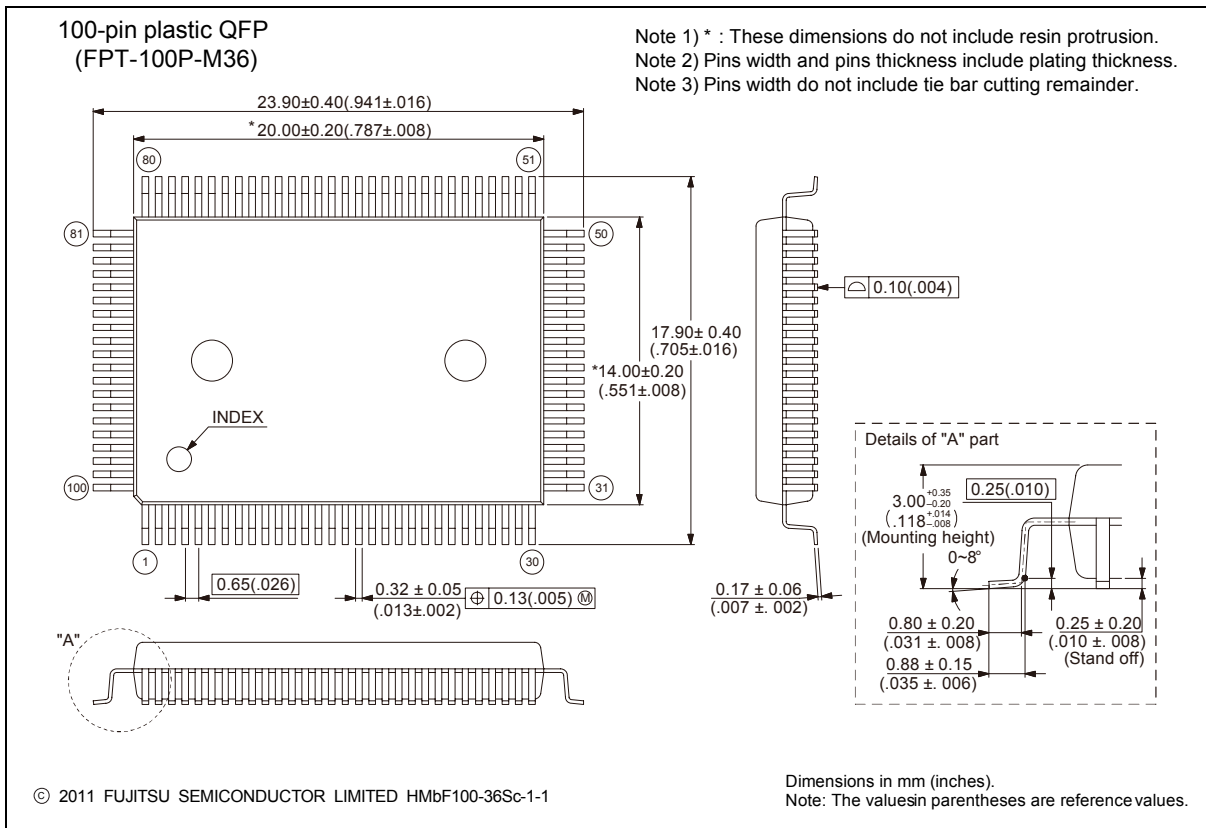

<p>80-pin plastic LQFP</p> <p>(FPT-80P-M37)</p>	Lead pitch	0.50 mm
	Package width × package length	12.00 mm × 12.00 mm
	Lead shape	Gullwing
	Lead bend direction	Normal bend
	Sealing method	Plastic mold
	Mounting height	1.70 mm MAX
	Weight	0.47 g

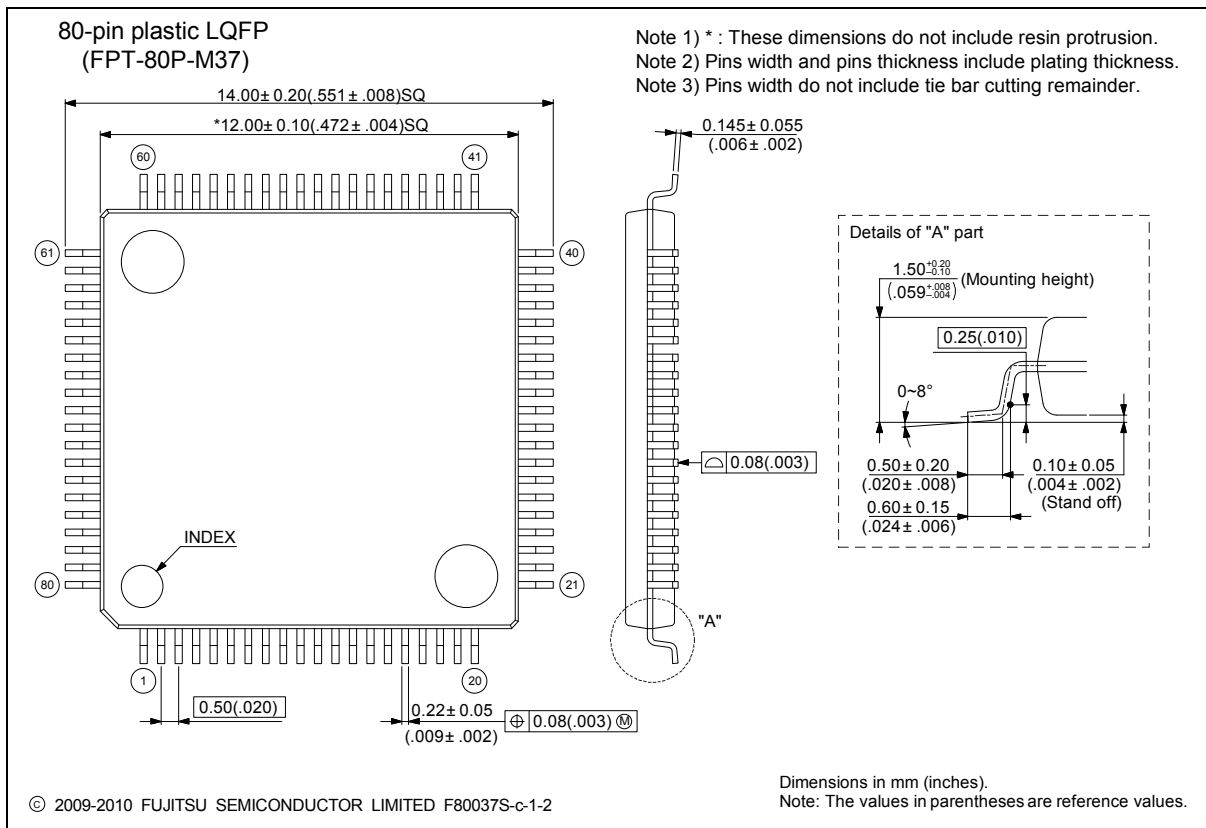

Please check the latest package dimension at the following URL.
<http://edevice.fujitsu.com/package/en-search/>

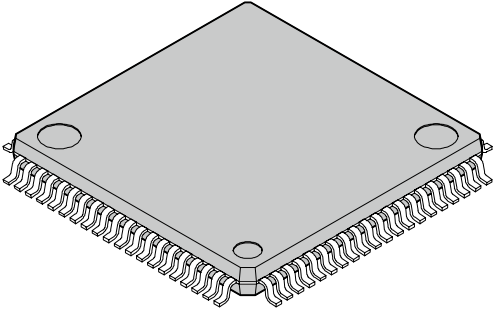
<p style="text-align: center;">80-pin plastic LQFP</p>  <p style="text-align: center;">(FPT-80P-M40)</p>	Lead pitch	0.65 mm
	Package width × package length	14.00 mm × 14.00 mm
	Lead shape	Gullwing
	Sealing method	Plastic mold
	Mounting height	1.60 mm Max.
	Code (Reference)	P-LQFP80-14 × 14-0.65

80-pin plastic LQFP
(FPT-80P-M40)

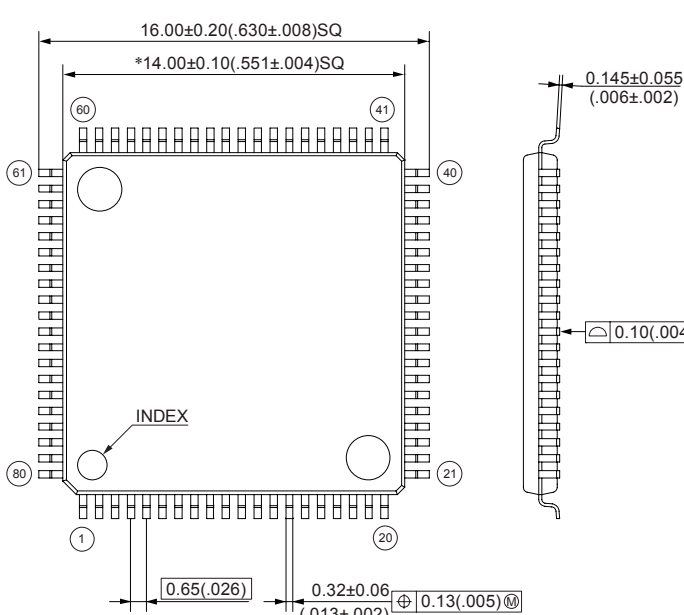

© 2012 FUJITSU SEMICONDUCTOR LIMITED HMBF80-40Sc-1-1

Note 1) * : These dimensions do not include resin protrusion.
 Note 2) Pins width and pins thickness include plating thickness.
 Note 3) Pins width do not include

Details of "A" part

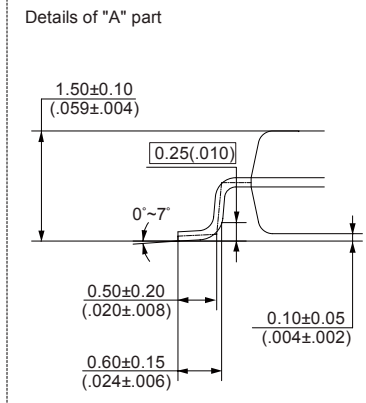

Dimensions in mm (inches).
 Note: The values in parentheses are reference values.

Please check the latest package dimension at the following URL.
<http://edevice.fujitsu.com/package/en-search/>

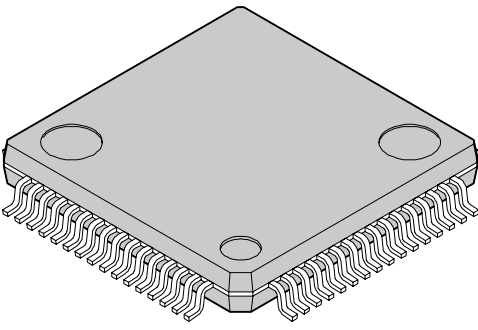
<p>64-pin plastic LQFP</p>  <p>(FPT-64P-M38)</p>	Lead pitch	0.50 mm
	Package width × package length	10.00 mm × 10.00 mm
	Lead shape	Gullwing
	Lead bend direction	Normal bend
	Sealing method	Plastic mold
	Mounting height	1.70 mm MAX
	Weight	0.32 g

64-pin plastic LQFP (FPT-64P-M38)

Note 1) * : These dimensions do not include resin protrusion.
 Note 2) Pins width and pins thickness include plating thickness.
 Note 3) Pins width do not include tie bar cutting remainder.

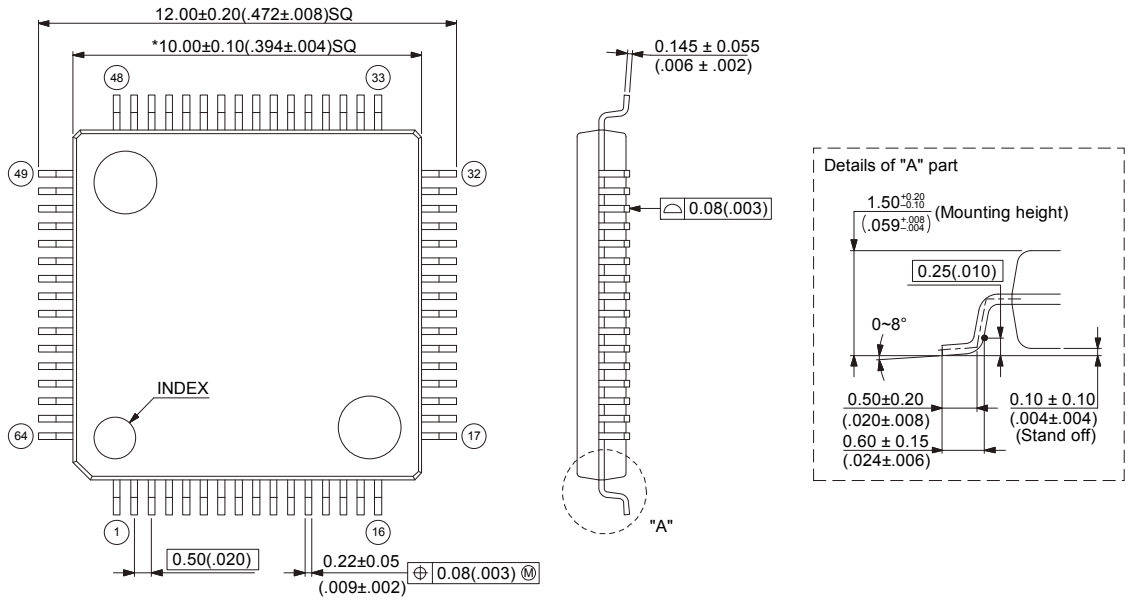

Dimensions in mm (inches).
 Note: The values in parentheses are reference values.

© 2010 FUJITSU SEMICONDUCTOR LIMITED F64038S-c-1-2

Please check the latest package dimension at the following URL.
<http://edevice.fujitsu.com/package/en-search/>

<p>64-pin plastic LQFP</p> <p>(FPT-64P-M39)</p>	Lead pitch	0.65 mm
	Package width × package length	12.00 mm × 12.00 mm
	Lead shape	Gullwing
	Sealing method	Plastic mold
	Mounting height	1.70 mm MAX
	Weight	0.47 g

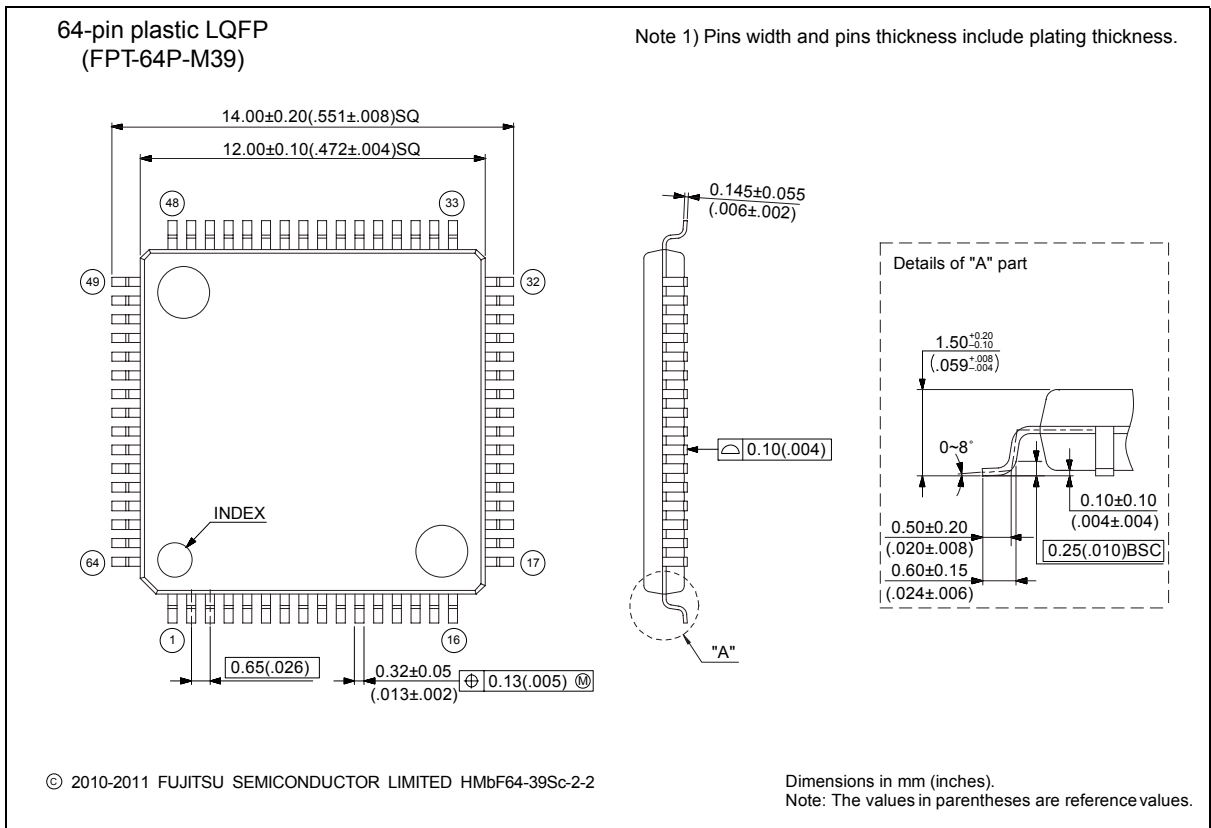

Please check the latest package dimension at the following URL.
<http://edevice.fujitsu.com/package/en-search/>

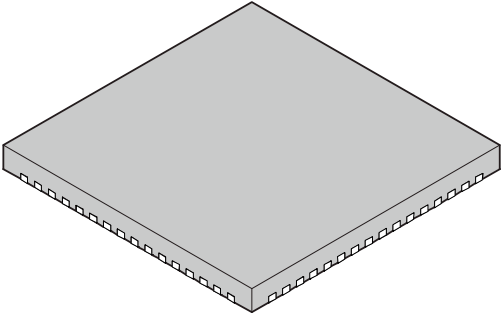
<p>64-pin plastic QFN</p>  <p>(LCC-64P-M24)</p>	Lead pitch	0.50 mm
	Package width × package length	9.00 mm × 9.00 mm
	Sealing method	Plastic mold
	Mounting height	0.90 mm MAX
	Weight	-

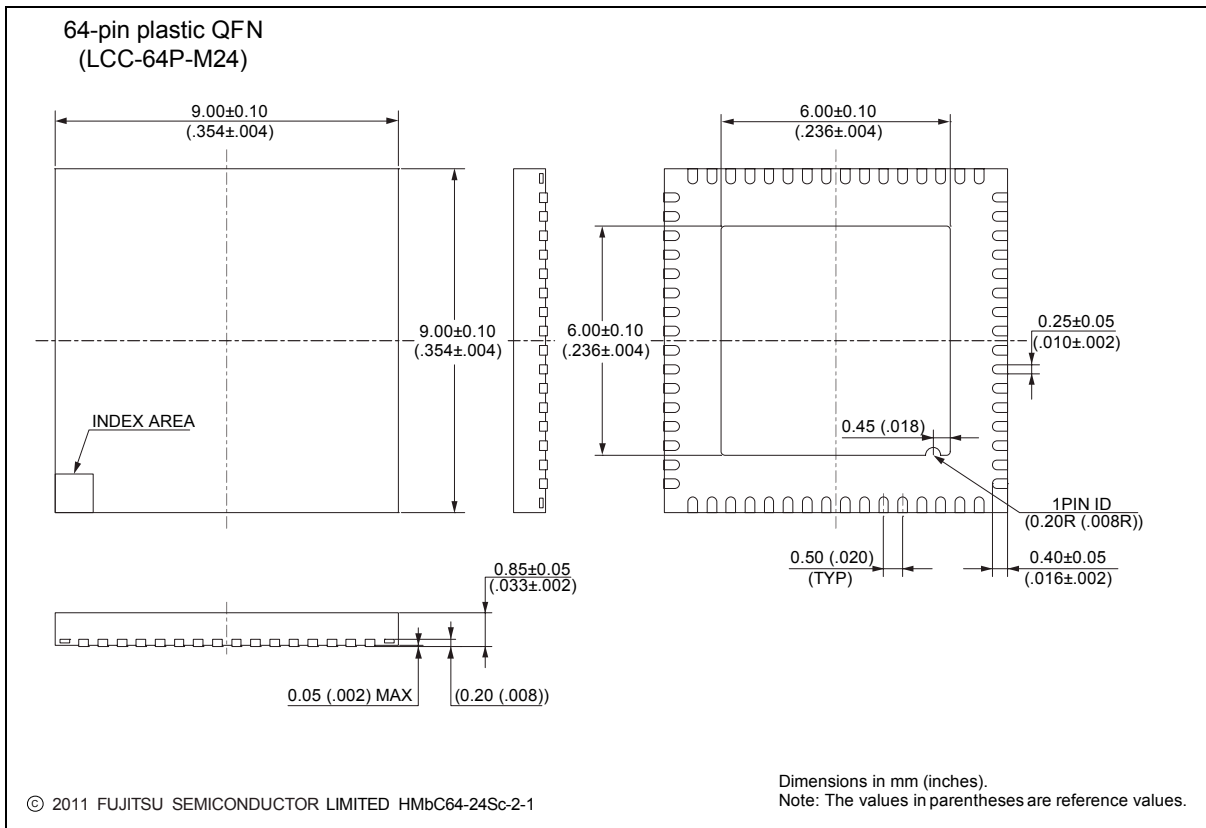

Please check the latest package dimension at the following URL.
<http://edevice.fujitsu.com/package/en-search/>

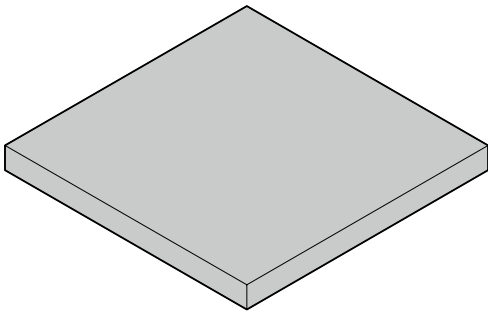
<p style="text-align: center;">112-ball plastic PFBGA</p>  <p style="text-align: center;">(BGA-112P-M04)</p>	Ball pitch	0.80 mm
	Package width × package length	10.00 × 10.00 mm
	Lead shape	Soldering ball
	Sealing method	Plastic mold
	Ball size	Φ 0.45 mm
	Mounting height	1.45 mm Max.
	Weight	0.22 g

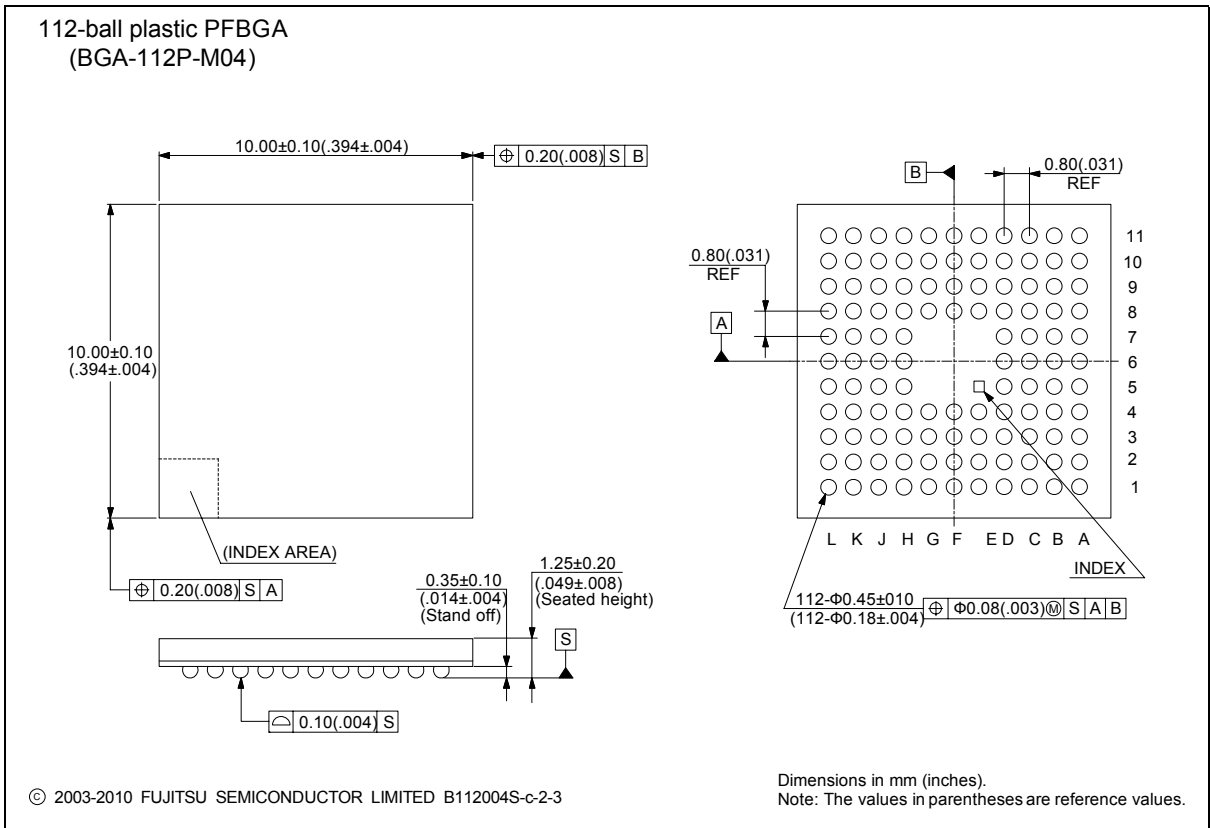

Please check the latest package dimension at the following URL.
<http://edevice.fujitsu.com/package/en-search/>

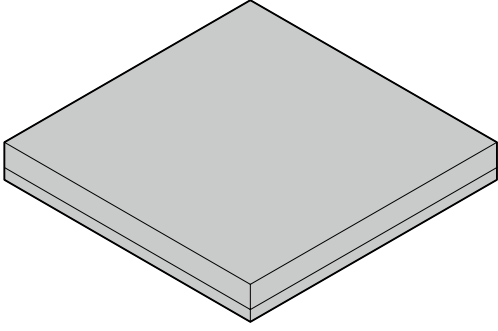
<p>96-pin plastic FBGA</p>  <p>(BGA-96P-M07)</p>	Lead pitch	0.5 mm
	Package width × package length	6.00 mm × 6.00 mm
	Lead shape	Ball
	Sealing method	Plastic mold
	Mounting height	1.30 mm MAX
	Weight	0.08 g

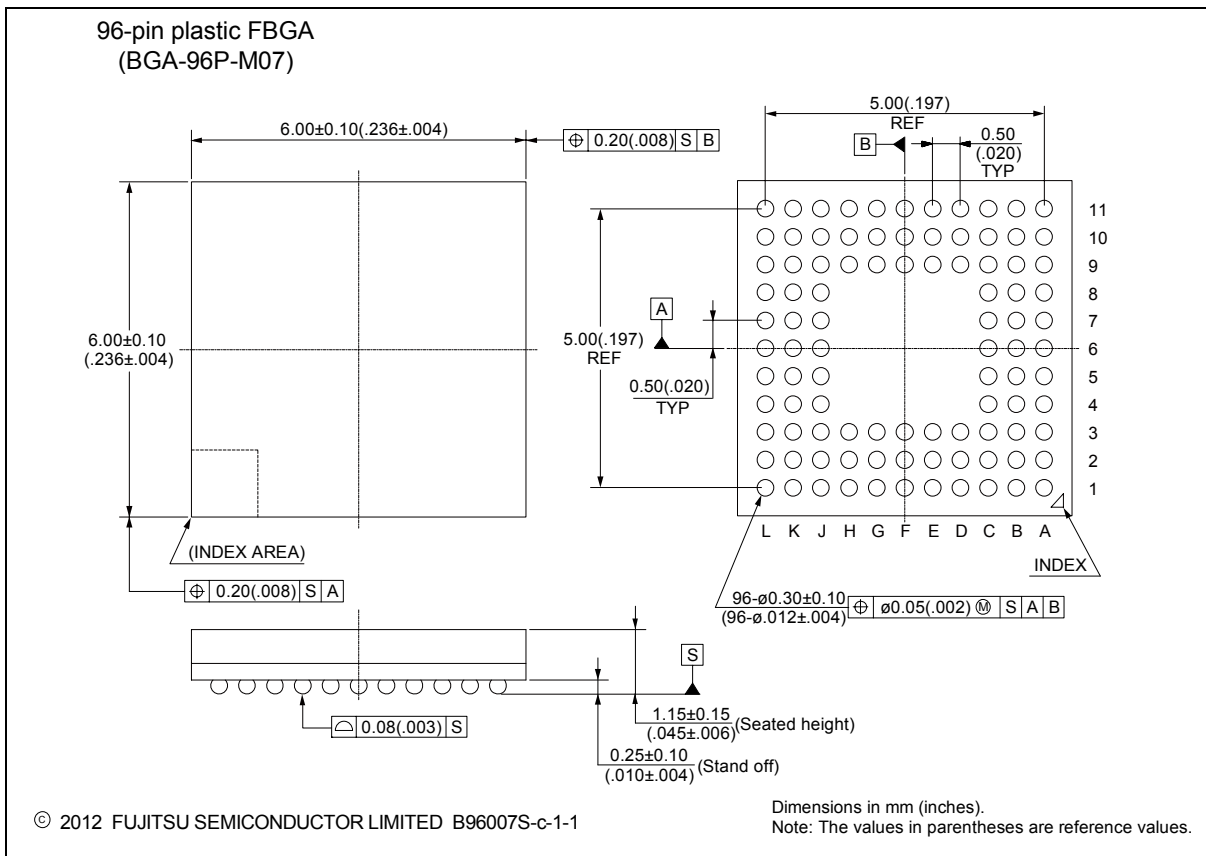

■ MAJOR CHANGES

Page	Section	Change Results
Revision 2.0		
2	■ FEATURE • On-chip Memories	Revised the descriptions of [Flash memory].
5	• Unique ID	Added the descriptions of "Unique ID".
6	■ PRODUCT LINEUP • Function	
48	■ HANDLING DEVICES	Added the descriptions.
53	■ MEMORY MAP • Memory Map (2)	
58	■ PIN STATUS IN EACH CPU STATE • List of Pin Status	Revised the Pin status type of "I".
65	■ ELECTRICAL CHARACTERISTICS 3.DC Characteristics (1) Current rating	• Revised the descriptions of Power supply current. • Added the "Flash memory write/erase current". • Added the footnote.
69	4.AC Characteristics (3) Built-in CR Oscillation Characteristics • Built-in high-speed CR	Revised the table and the footnote.
73, 74	(7) External Bus Timing • Separate Bus Access Asynchronous SRAM Mode	Revised the table and the figure.
75	• Separate Bus Access Synchronous SRAM Mode	
80, 82, 84, 86	(9) CSIO Timing	• Revised the title to "CSIO Timing". • Revised the note.
89	(11) I ² C Timing	Revised the footnote.
92	5. 12-bit A/D Converter • Electrical Characteristics for the A/D Converter	• Revised the parameter. • Revised the symbol. • Corrected the value.
94	• Definition of 12-bit A/D Converter Terms	• Revised the parameter. • Revised the symbol.
95	6. Low-Voltage Detection Characteristics (1) Low-Voltage Detection Reset	• Corrected "Conditions" and "Value" in the table. • Added the Item. • Added the footnote.
96	(2) Interrupt of Low-Voltage Detection	Added the Item.
Revision 2.1		
-	-	Company name and layout design change

Colophon

The products described in this document are designed, developed and manufactured as contemplated for general use, including without limitation, ordinary industrial use, general office use, personal use, and household use, but are not designed, developed and manufactured as contemplated (1) for any use that includes fatal risks or dangers that, unless extremely high safety is secured, could have a serious effect to the public, and could lead directly to death, personal injury, severe physical damage or other loss (i.e., nuclear reaction control in nuclear facility, aircraft flight control, air traffic control, mass transport control, medical life support system, missile launch control in weapon system), or (2) for any use where chance of failure is intolerable (i.e., submersible repeater and artificial satellite). Please note that Spansion will not be liable to you and/or any third party for any claims or damages arising in connection with above-mentioned uses of the products. Any semiconductor devices have an inherent chance of failure. You must protect against injury, damage or loss from such failures by incorporating safety design measures into your facility and equipment such as redundancy, fire protection, and prevention of over-current levels and other abnormal operating conditions. If any products described in this document represent goods or technologies subject to certain restrictions on export under the Foreign Exchange and Foreign Trade Law of Japan, the US Export Administration Regulations or the applicable laws of any other country, the prior authorization by the respective government entity will be required for export of those products.

Trademarks and Notice

The contents of this document are subject to change without notice. This document may contain information on a Spansion product under development by Spansion. Spansion reserves the right to change or discontinue work on any product without notice. The information in this document is provided as is without warranty or guarantee of any kind as to its accuracy, completeness, operability, fitness for particular purpose, merchantability, non-infringement of third-party rights, or any other warranty, express, implied, or statutory. Spansion assumes no liability for any damages of any kind arising out of the use of the information in this document.

Copyright © 2013-2014 Spansion Inc. All rights reserved. Spansion®, the Spansion logo, MirrorBit®, MirrorBit® Eclipse™, ORNAND™ and combinations thereof, are trademarks and registered trademarks of Spansion LLC in the United States and other countries. Other names used are for informational purposes only and may be trademarks of their respective owners.

X-ON Electronics

Largest Supplier of Electrical and Electronic Components

Click to view similar products for [ARM Microcontrollers - MCU category](#):

Click to view products by [Cypress manufacturer](#):

Other Similar products are found below :

[R7FS3A77C2A01CLK#AC1](#) [MB96F119RBPMC-GSE1](#) [MB9BF122LPMC1-G-JNE2](#) [MB9BF122LPMC-G-JNE2](#) [MB9BF128SAPMC-GE2](#)
[MB9BF218TBGL-GE1](#) [MB9BF529TBGL-GE1](#) [26-21/R6C-AT1V2B/CT](#) [5962-8506403MQA](#) [MB9AF342MAPMC-G-JNE2](#)
[MB96F001YBPMC1-GSE1](#) [MB9BF121KPMC-G-JNE2](#) [VA10800-D000003PCA](#) [CP8547AT](#) [CY9AF156NPMC-G-JNE2](#)
[MB9BF104NAPMC-G-JNE1](#) [NHS3152UK/A1Z](#) [MK26FN2M0CAC18R](#) [EFM32TG230F32-D-QFN64](#) [EFM32TG232F32-D-QFP64](#)
[EFM32TG825F32-D-BGA48](#) [MB9AFB44NBBGL-GE1](#) [MB9BF304RBPMC-G-JNE2](#) [MB9BF416RPMC-G-JNE2](#) [MB9AF155MABGL-GE1](#)
[MB9BF306RBPMC-G-JNE2](#) [MB9BF618TBGL-GE1](#) [ATSAMS70N21A-CN](#) [LPC1754FBD80](#) [STM32F030K6T6TR](#) [AT91M42800A-33AU](#)
[ATSAM3N0AA-MU](#) [ATSAM3N0CA-CU](#) [ATSAM3SD8BA-MU](#) [ATSAM4LC2BA-UUR](#) [ATSAM4LS2AA-MU](#) [ADuC7023BCPZ62I-R7](#)
[ATSAM4LS4CA-CFU](#) [ADUCM3027BCPZ-R7](#) [ADUCM3027BCPZ-RL](#) [ADUCM3029BCPZ-R7](#) [LPC2141FBD64.151](#) [CEC1702Q-B1-SX](#)
[ADUC7020BCPZ62IRL7](#) [TMS5701114CZWTQQ1](#) [TM4C123AE6PMIR](#) [S6E2H14G0AGV20000](#) [ATSAMD20J15B-AU](#) [ATSAMD20J16B-](#)
[MN](#) [ATSAMV71N20B-CB](#)