

# EZ-BLE™ PRoC™ EVALUATION BOARD

## CYBLE-222014-EVAL



The EZ-BLE™ PRoC™ Evaluation Board (CYBLE-222014-EVAL) enables you to evaluate and develop applications on the EZ-BLE PRoC Module (CYBLE-222014-01). The EZ-BLE PRoC Module is a fully-integrated, fully-certified, 10 mm x 10 mm x 1.8 mm, programmable, Bluetooth® Smart module designed to reduce your time-to-market.

For more information visit:

[www.cypress.com/EZ-BLEModule](http://www.cypress.com/EZ-BLEModule) - The EZ-BLE Module home page.

[www.cypress.com/EZ-BLEEval](http://www.cypress.com/EZ-BLEEval) - The EZ-BLE PRoC Evaluation Board kit page.

[www.cypress.com/go/AN96841](http://www.cypress.com/go/AN96841) - The getting started guide.

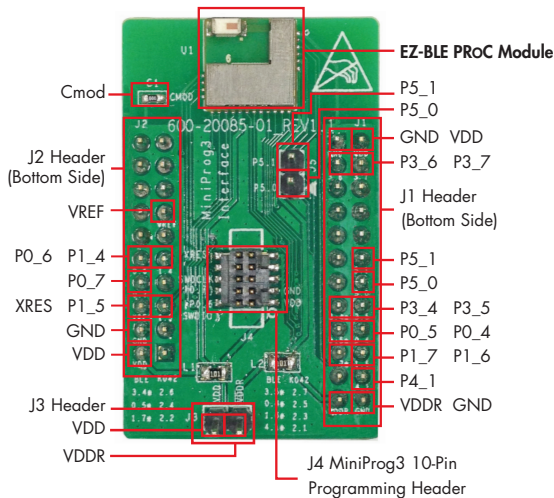

**Fig 1: CYBLE-222014-EVAL Pinout Description**

Note: To use the CYBLE-222014-EVAL you must separately purchase either the CY8CKIT-002 MINIPROG3 or the CY8CKIT-042-BLE BLE PIONEER KIT.

# EZ-BLE™ PROc™ EVALUATION BOARD

**1:** Connect the CYBLE-222014-EVAL to the CY8CKIT-002 (MiniProg3)

Connect a jumper on the J3 header

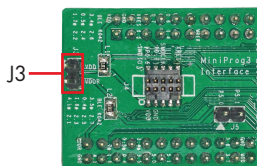

**Fig 2: J3 Header**

Connect the MiniProg3 to the J4 10-pin header

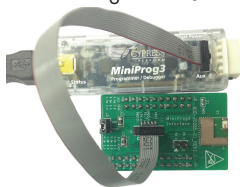

**Fig 3: Programming/Debugging with MiniProg3**

**OR**

Plug the CYBLE-222014-EVAL on the CY8CKIT-042-BLE baseboard.

Note: Jumper on CYBLE-222014-EVAL's J3 header can be connected or disconnected.



**Fig 4: Programming and debugging with CY8CKIT-042-BLE BLE Pioneer Kit Baseboard**

Pin Mapping between CY8CKIT-042-BLE (Base) and CYBLE-222014-EVAL (Eval)

(Base)	(Eval)	(Base)	(Eval)	(Base)	(Eval)	(Base)	(Eval)
GND	GND	P2_4	PO_5	P2_3	P1_6	P3_7	P3_7
VDDD, VDDDA	VDD	PO_6	PO_6	P2_2	P1_7	P2_1	P4_1
VDDR	VDDR	PO_7	PO_7	P2_6	P3_4	P5_0	P5_0
XRES	XRES	P1_4	P1_4	P2_7	P3_5	P5_1	P5_1
P2_5	PO_4	P1_5	P1_5	P3_6	P3_6	VREF	VREF

**2:** Create a project using the CYBLE-222014-01 MPN and program/debug using PSoC® Creator™ 3.3

The EZ-BLE PROc Module is qualified for the Bluetooth 4.2 specification and is certified for the 2.4 GHz unlicensed frequency range in USA (FCC), Canada (IC), Europe (CE), Japan (TELEC) and Korea (KC).

Visit [www.cypress.com/go/support](http://www.cypress.com/go/support) for technical support

## X-ON Electronics

Largest Supplier of Electrical and Electronic Components

*Click to view similar products for [Bluetooth Development Tools - 802.15.1 category](#):*

*Click to view products by [Cypress manufacturer](#):*

Other Similar products are found below :

[DA14580PRODTLKT](#) [1628](#) [SP14808ST](#) [MBH7BLZ02-EF-KIT](#) [FWM7BLZ20-EB-KIT](#) [SP14801-DUT](#) [SKY66111-21EK1](#) [SECO-RSL10-TAG-GEVB](#) [ENW89857AXKF](#) [3026](#) [MIKROE-2471](#) [MOD-NRF8001](#) [BLE-IOT-GEVB](#) [450-0184](#) [EKSHCNZXZ](#) [EVAL\\_PAN1026](#)  
[EVAL\\_PAN1720](#) [EVAL\\_PAN1740](#) [2267](#) [2479](#) [2487](#) [2633](#) [STEVAL-IDB005V1D](#) [STEVAL-IDB001V1](#) [MIKROE-2545](#) [SIPKITSLF001](#)  
[2995](#) [STEVAL-IDB007V1M](#) [2829](#) [DFR0267](#) [DFR0296](#) [DFR0492](#) [TEL0073](#) [BM-70-CDB](#) [WSM-BL241-ADA-008DK](#) [STEVAL-BTDP1](#)  
[ACD52832](#) [TEL0095](#) [ISP1507-AX-TB](#) [RN-4871-PICTAIL](#) [DA14695-00HQDEVKT-P](#) [DA14695-00HQDEVKT-U](#) [EBSHJNZXZ](#)  
[EKSGJNZWY](#) [EKSHJNZXZ](#) [BMD-200-EVAL-S](#) [ACN BREAKOUT BOARD](#) [ACN SKETCH](#) [2269](#) [2746](#)