

---

---

## Low EMI Spectrum Spread Clock

### Features

- Spread Spectrum clock generator (SSCG) with 1x, 2x, and 4x outputs
- 6- to 82-MHz operating frequency range
- Modulates external clocks including crystals, crystal oscillators, or ceramic resonators
- Programmable modulation with simple R-C external loop filter (LF)
- Center spread modulation
- 3V-5V power supply
- TTL-/CMOS-compatible outputs
- Low short-term jitter
- Low-power Dissipation
  - 3.3 VDC = 37 mW – typical
  - 5.0 VDC = 115 mW – typical
- Available in 8-pin SOIC and TSSOP packages

### Applications

- Desktop/notebook computers
- Printers, copiers, and MFP
- Scanners and fax
- LCD displays and monitors
- CD-ROM, VCD, and DVD
- Automotive and embedded systems
- Networking, LAN/WAN
- Digital cameras and camcorders
- Modems

### Benefits

- Programmable EMI reduction
- Fast time to market
- Lower cost of compliance
- No degradation in rise/fall times
- Lower component and PCB layer count

### Functional Description

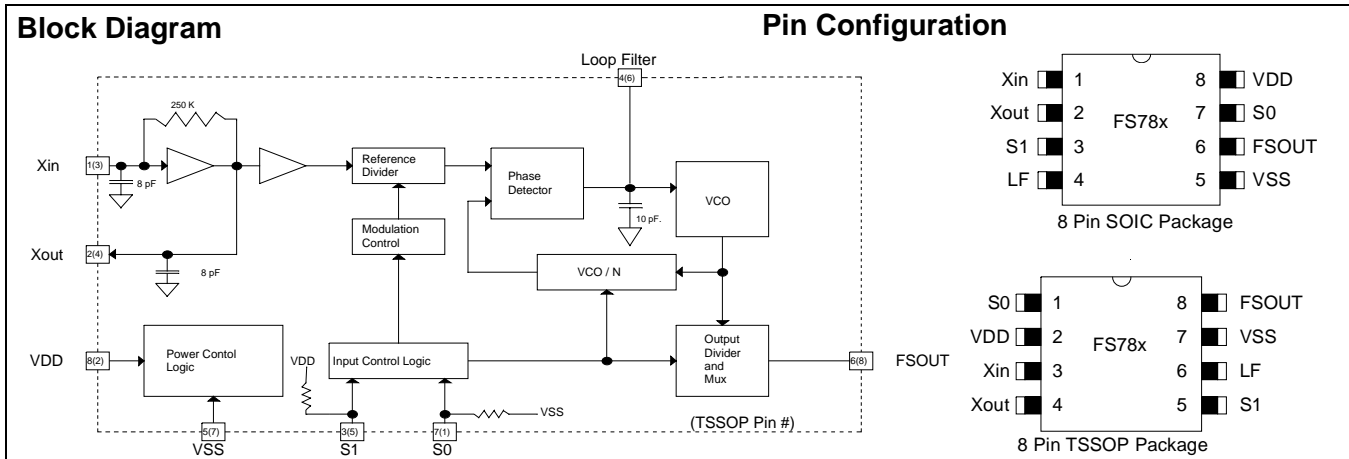
The Cypress FS781/82/84 are Spread Spectrum clock generator ICs (SSCG) designed for the purpose of reducing electromagnetic interference (EMI) found in today's high-speed digital systems.

The FS781/82/84 SSCG clocks use a Cypress-proprietary technology to modulate the input clock frequency, XIN, by modulating the frequency of the digital clock. By modulating the reference clock the measured EMI at the fundamental and harmonic frequencies of FSOUT is greatly reduced. This reduction in radiated energy can significantly reduce the cost of complying with regulatory requirements without degrading digital waveforms.

The Cypress FS781/82/84 clocks are very simple and versatile devices to use. By programming the two range select lines, S0 and S1, any frequency from 6- to 82-MHz operating range can be selected. The FS781/2/4 are designed to operate over a very wide range of input frequencies and provides 1x, 2x, and 4x modulated clock outputs.

The FS78x devices have a simple frequency selection table that allows operation from 6 MHz to 82 MHz in four separate ranges. The bandwidth of the frequency spread at FSOUT is determined by the values of the loop filter components. The modulation rate is determined internally by the input frequency and the selected input frequency range.

The Bandwidth of these products can be programmed from as little as 1.0% up to as much as 4.0% by selecting the proper loop filter value. Refer to the Loop Filter Selection chart in *Table 2* and *Table 3* for the recommended values. Due to a wide range of application requirements, an external loop filter (LF) is used on the FS78x products. The user can select the exact amount of frequency modulation suitable for the application. Using a fixed internal loop filter would severely limit the use of a wide range of modulation bandwidths (Spread %) to a few discrete values. Refer to FS791/2/4 products for applications requiring 80- to 140-MHz frequency range.



## Pin Description

Pin	Name	I/O	Type	Description
1/2 (SOIC) 3/4 (TSSOP)	X <sub>IN</sub> /X <sub>OUT</sub>	I/O	Analog	<b>Pins form an on-chip reference oscillator when connected to terminals of an external parallel resonant crystal.</b> X <sub>IN</sub> may be connected to TTL/CMOS external clock source. If X <sub>IN</sub> is connected to an external clock other than crystal, leave X <sub>OUT</sub> (pin 2) unconnected.
7/3 (SOIC) 1/5 (TSSOP)	S0 / S1	I	CMOS/TTL	<b>Digital control inputs to select input frequency range and output frequency scaling.</b> Refer to <i>Table 2</i> and <i>Table 3</i> for selection. S0 has internal pull-down. S1 has internal pull-up.
4 (SOIC) 6 (TSSOP)	LF	I	Analog	<b>Loop Filter.</b> Single ended three-state output of the phase detector. A two-pole passive loop filter is connected to LF.
6 (SOIC) 8 (TSSOP)	FSOUT	O	CMOS/TTL	<b>Modulated Clock Frequency Output.</b> The center frequency is the same as the input reference frequency for FS781. Input frequency is multiplied by 2x and 4x for FS782 and FS784, respectively.
8 (SOIC) 2 (TSSOP)	V <sub>DD</sub>	P	Power	<b>Positive Power Supply.</b>
5 (SOIC) 7 (TSSOP)	V <sub>SS</sub>	P	Power	<b>Power Supply Ground.</b>

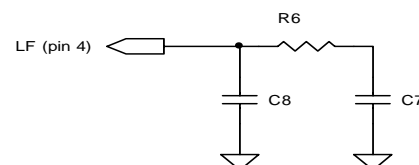
## Output Frequency Selection

**Table 1. FSOUT SSCG (Modulated Output Clock) Product Selection**

Product Number	FSOUT Frequency Scaling	Description
FS781	1x	1x modulated frequency of input clock
FS782	2x	2x modulated frequency of input clock
FS784	4x	4x modulated frequency of input clock

## Loop Filter Selection Chart

The following table provides a list of recommended loop filter values for the FS781/82/84. The FS78X is divided into four ranges and operated at both 3.3V and 5.5 VDC. The loop filter at the right is representative of the loop filter components in *Table 2*.



**Table 2. FS781/82/84 Recommended Loop Filter Values C7 (pF) @ +3.3 VDC ±5% (R6 = 3.3K)<sup>[1, 2, 3, 4]</sup>**

Input MHz	S1	S0	BW = 1.0% <sup>[3]</sup>	BW = 1.5% <sup>[3]</sup>	BW = 2.0% <sup>[3]</sup>	BW = 2.5% <sup>[3]</sup>	BW = 3.0% <sup>[3]</sup>	BW = 3.5% <sup>[3]</sup>	BW = 4.0% <sup>[3]</sup>
6	0	0	10,000/1000	1550	910	780	700	640	560
8	0	0	10,000/330	990	820	640	520	450	400
10	0	0	1040	680	460	360	300	240	210
12	0	0	830	420	300	220	200	190	170
14	0	0	580	230	200	160	140	100	80
16	0	1	10000	980	760	580	470	410	385
18	0	1	1200	750	580	470	415	370	300
20	0	1	1000	730	470	390	320	220	190
22	0	1	960	640	410	270	230	200	180
24	0	1	920	400	250	210	180	160	150
26	0	1	660	300	220	180	150	140	120
28	0	1	470	230	180	150	130	100	70
30	0	1	470	180	140	120	100	80	60
32	0	1	330	170	120	100	82	68	47
34	1	0	10000	860	640	520	430	380	330
36	1	0	2200	820	620	470	400	330	290
38	1	0	1500	690	520	410	340	290	240
40	1	0	960	600	420	340	280	220	160
42	1	0	940	620	380	275	230	210	180
44	1	0	950	680	400	250	210	190	170
46	1	0	900	580	270	220	190	180	165
48	1	0	790	440	260	210	180	160	140
50	1	0	660	360	250	190	170	150	140
52	1	0	470	325	220	185	155	135	120
54	1	0	470	270	200	170	140	130	100
56	1	0	445	250	185	150	120	85	47
58	1	0	430	210	165	130	100	65	33
60	1	0	295	185	150	120	100	90	82
62	1	0	270	220	150	120	100	82	68
64	1	1	1180	860	560	410	340	290	230
65	1	1	1180	850	540	400	330	280	220
66	1	1	1180	760	560	350	260	220	210
68	1	1	1180	750	500	320	260	230	210
70	1	1	1120	740	470	370	300	240	170
72	1	1	1160	780	470	300	250	220	190
74	1	1	1110	770	470	280	230	210	190
76	1	1	1000	720	440	240	210	190	170
78	1	1	910	670	270	210	190	170	160
80	1	1	900	620	260	210	190	170	156
82	1	1	900	540	250	210	190	170	150

**Notes:**

1. If the value selected from the above chart is not a standard, use the next available larger value.
2. All bandwidths indicated above are total peak-to-peak spread. 1% = +0.5% to -0.5%. 4% = +2.0% to -2.0%.
3. If C8 is not listed in the chart for a particular bandwidth and frequency, it is not used in the loop filter.
4. Contact Cypress for LF values less than 1.0% bandwidth.

**Table 3. FS781/82/84 Recommended Loop Filter Values C7 (pF) @ +5.0 VDC ±5% (R6 = 3.3K)<sup>[1, 2, 3, 4]</sup>**

Input MHz	S1	S0	BW = 1.0% <sup>[3]</sup>	BW = 1.5% <sup>[3]</sup>	BW = 2.0% <sup>[3]</sup>	BW = 2.5% <sup>[3]</sup>	BW = 3.0% <sup>[3]</sup>	BW = 3.5% <sup>[3]</sup>	BW = 4.0% <sup>[3]</sup>
6	0	0	1140	1030	930	830	710	610	510
8	0	0	1170	970	740	570	460	400	280
10	0	0	1030	660	430	350	280	210	130
12	0	0	760	340	230	200	180	160	130
14	0	0	450	240	180	140	100	70	50
16	0	1	2490	970	730	590	480	430	370
18	0	1	2490	870	650	510	430	370	310
20	0	1	1360	680	480	370	280	190	250
22	0	1	990	560	330	260	230	200	190
24	0	1	820	360	250	200	180	160	150
26	0	1	530	270	210	170	150	110	90
28	0	1	430	230	180	150	110	100	90
30	0	1	250	200	150	110	100	90	80
32	1	0	Note 4	1000	740	570	470	410	370
34	1	0	Note 4	990	710	520	420	360	300
36	1	0	Note 4	970	670	480	380	310	230
38	1	0	Note 4	880	560	380	310	270	220
40	1	0	Note 4	800	460	290	240	230	220
42	1	0	1030	680	360	260	220	200	190
44	1	0	790	560	260	220	200	190	170
46	1	0	1110	420	280	210	180	170	140
48	1	0	1110	280	200	190	170	140	120
50	1	0	830	330	200	180	160	130	110
52	1	0	560	340	205	170	140	120	90
54	1	0	510	280	180	140	110	110	90
56	1	0	470	210	160	120	100	90	90
58	1	0	450	220	250	110	90	80	80
60	1	0	430	240	120	90	80	80	70
62	1	1	Note 4	800	580	430	330	250	180
64	1	1	Note 4	720	490	375	285	200	140
66	1	1	Note 4	630	400	320	240	150	100
68	1	1	Note 4	690	365	285	225	170	140
70	1	1	Note 4	650	330	250	210	190	180
72	1	1	Note 4	575	340	250	210	190	170
74	1	1	Note 4	500	355	245	205	180	165
76	1	1	Note 4	550	330	230	200	175	160
78	1	1	Note 4	600	290	220	190	170	155
80	1	1	Note 4	570	240	210	185	165	150
82	1	1	Note 4	540	250	200	180	160	140

**Table 4. Modulation Rate Divider Ratios**

S1	S0	Input Frequency Range (MHz)	Modulation Divider Number
0	0	6 to 16	120
0	1	16 to 32	240
1	0	32 to 66	480
1	1	66 to 82	720

### SSCG Modulation Profile

The digital control inputs S0 and S1 determine the modulation frequency of FS781/2/4 products. The input frequency is divided by a fixed number, depending on the operating range that is selected. The modulation frequency of the FS78x can be determined from *Table 4*. To compute the modulation frequency, determine the values of S0 and S1, and find the modulation divider number in *Table 4*.

### Theory of Operation

The FS781/82/84 devices are phase-locked loop-(PLL)-type clock generators using Direct Digital Synthesis (DDS). By precisely controlling the bandwidth of the output clock, the FS781/2/4 products become a low-EMI clock generator. The theory and detailed operation of these products will be discussed in the following sections.

### EMI

All clocks generate unwanted energy in their harmonics. Conventional digital clocks are square waves with a duty cycle that is very close to 50%. Because of the 50/50 duty cycle, digital clocks generate most of their harmonic energy in the odd harmonics (e.g., third, fifth, seventh). It is possible to reduce the amount of energy contained in the fundamental and harmonics by increasing the bandwidth of the fundamental clock frequency. Conventional digital clocks have a very high Q factor, which means that all of the energy at that frequency is concentrated in a very narrow bandwidth, conse-

quently, higher energy peaks. Regulatory agencies test electronic equipment by the amount of peak energy radiated from the equipment. By reducing the peak energy at the fundamental and harmonic frequencies, the equipment under test is able to satisfy agency requirements for EMI. Conventional methods of reducing EMI have been to use shielding, filtering, multi-layer PCBs, etc. These FS781/2 and 4 reduce the peak energy in the clock by increasing the clock bandwidth and lowering the Q of the clock.

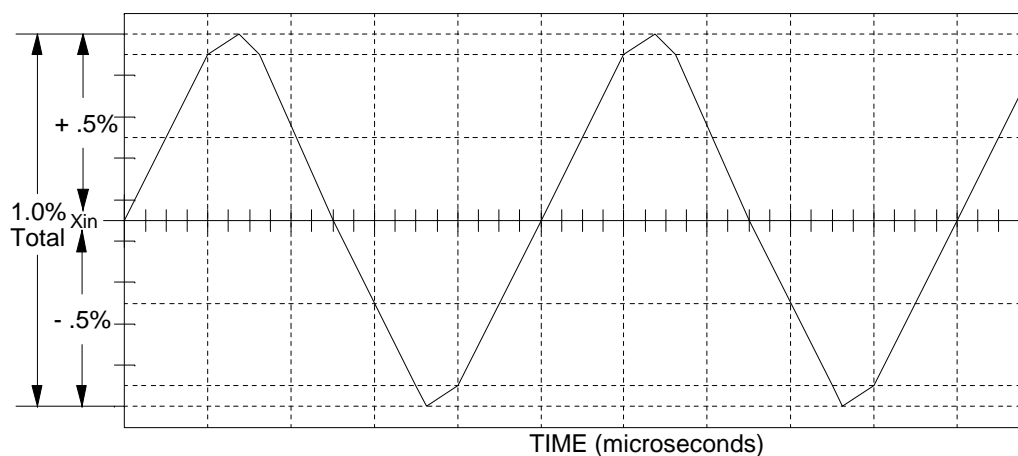
### SSCG

The FS781/82/84 products use a unique method of modulating the clock over a very narrow bandwidth and controlled rate of change, both peak to peak and cycle to cycle. The FS78x products take a narrow band digital reference clock in the range of 6–82 MHz and produce a clock that sweeps between a controlled start and stop frequency and precise rate of change. To understand what happens to an SSCG clock, consider that we have a 20-MHz clock with a 50% duty cycle. From a 20-MHz clock we know the following:

Clock Frequency =  $F_c = 20 \text{ MHz}$ .

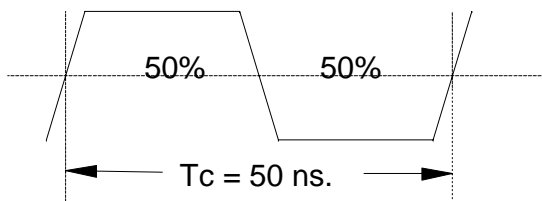
Clock Period =  $T_c = 1/20 \text{ MHz} = 50 \text{ ns}$ .

Consider that this 20-MHz clock is applied to the  $X_{IN}$  input of the FS78x as either an externally driven clock or the result of a parallel resonant crystal connected to pins 1 and 2 of the FS78x. Also consider that the products are operating from a 5V DC power supply and the loop filter is set for a total bandwidth spread of 2%. Refer to *Figure 2*.


**Figure 1. Frequency Profile in Time Domain<sup>[5]</sup>**

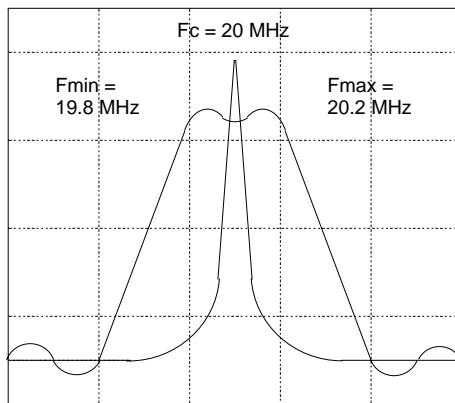
**Note:**

5. With the correct loop filter connected to Pin 4, the following profile will provide the best EMI reduction. This profile can be seen on a Time Domain Analyzer.

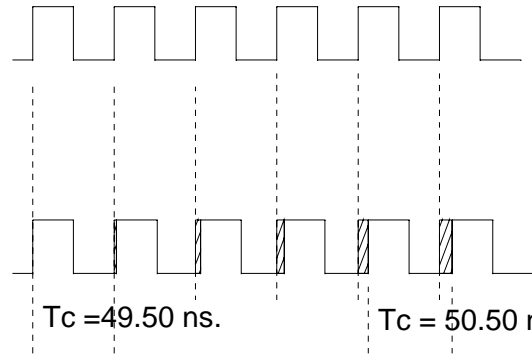

**Figure 2. 20-MHz Unmodulated Clock**

From the above parameters, the output clock at FSOUT will be sweeping symmetrically around a center frequency of 20 MHz.

The minimum and maximum extremes of this clock will be +200 kHz and -200 kHz. So we have a clock that is sweeping from 19.8 MHz to 20.2 MHz and back again. If we were to look at this clock on a spectrum analyzer we would see the picture in *Figure 3*. Keep in mind that this is a drawing of a perfect clock with no noise.


**Figure 3. Spectrum Analysis of 19.8–20.2 MHz Clock**

We see that the original 20-MHz reference clock is at the center frequency ( $F_c$ ), and the min. and max. extremes are positioned symmetrically about the center frequency. This type of modulation is called Center-Spread. *Figure 4* shows a 20-MHz clock as it would be seen on an oscilloscope. The top trace is the non-modulated reference clock. The bottom trace is the modulated clock at pin 6. From this comparison chart you can see that the frequency is decreasing and the period of each successive clock is increasing. The  $T_c$  measurements on the left and right of the bottom trace indicate the max. and min. extremes of the clock. Intermediate clock changes are small and accumulate to achieve the total period deviation. The reverse of this figure would show the clock going from minimum extreme back to the high extreme.


**Figure 4. Period Comparison Chart**

Looking at *Figure 3*, you will note that the peak amplitude of the 20-MHz non-modulated clock is higher than the wideband modulated clock. This difference in peak amplitudes between modulated and unmodulated clocks is the reason why SSCG clocks are so effective in digital systems. This figure refers to the fundamental frequency of a clock. A very important characteristic of the SSCG clock is that the bandwidth of the fundamental frequency is multiplied by the harmonic number. In other words, if the bandwidth of a 20-MHz clock is 200 kHz, the bandwidth of the third harmonic will be  $3 \times 200$ , or 600 kHz. The amount of bandwidth is relative to the amount of energy in the clock. Consequently, the wider the bandwidth, the greater the energy reduction of the clock.

Most applications will not have a problem meeting agency specifications at the fundamental frequency. It is the higher harmonics that usually cause the most problems. With an SSCG clock, the bandwidth and peak energy reduction increases with the harmonic number. Consider that the eleventh harmonic of a 20-MHz clock is 220 MHz. With a total spread of 200 kHz at 20 MHz, the spread at the eleventh harmonic would be 2.20 MHz, which greatly reduces the peak energy content. It is typical to see as much as 12- to 18-dB reduction at the higher harmonics, due to a modulated clock.

The difference in the peak energy of the modulated clock and the non-modulated clock in typical applications will see a 2 – 3 dB reduction at the fundamental and as much as 8 – 10 dB reduction at the intermediate harmonics: third, fifth, seventh, etc. At the higher harmonics, it is quite possible to reduce the peak harmonic energy, compared to the unmodulated clock, by as much as 12 to 18 dB.

### Application Notes and Schematic

*Figure 5* is configured for the following parameters:

Package selected = FS781.

$X_{IN}$  = 20-MHz crystal

FSOUT = 20 MHz ( $S_0 = 1$  and  $S_1 = 0$ ).

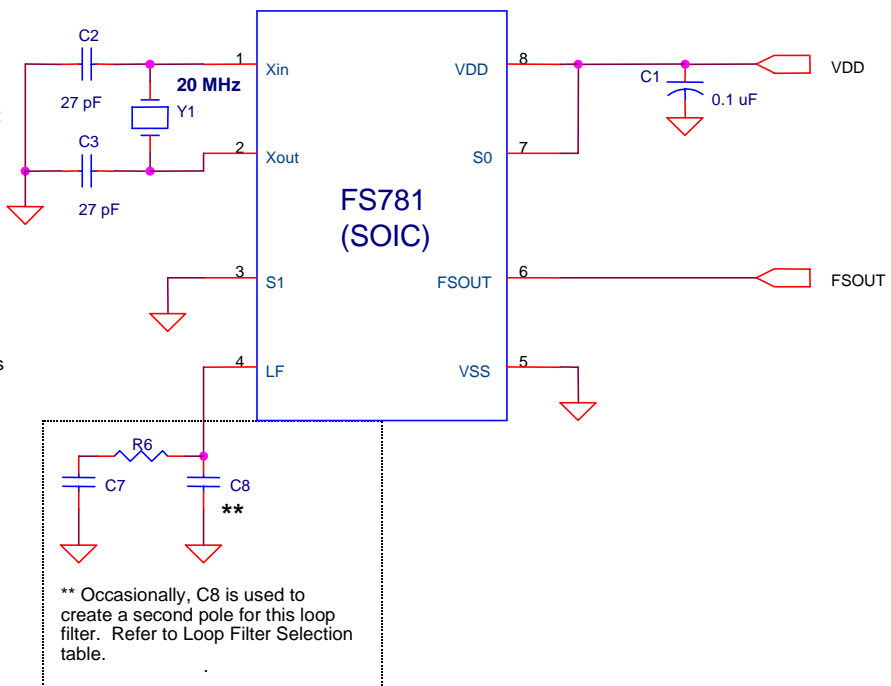
Bandwidth of the FSOUT clock is determined by the values of the loop filter connected to pin 4.

Crystal is 20 MHz is 1st Order with 18 pF load capacitance.

If Crystal load capacitance is different than 18 pF, C1 and C2 must be re-calculated.

For third overtone crystals, a parallel or series resonant trap is required.

Mount loop filter components as close to LF pin as possible.



**Figure 5. FS781 Schematic**

**Absolute Maximum Ratings<sup>[6]</sup>**

This device contains circuitry to protect the input against damage due to high static voltages or electric fields; however, precautions should be taken to avoid application of any voltage higher than the absolute maximum rated voltages to

this circuit. For proper operation,  $V_{IN}$  and  $V_{OUT}$  should be constrained to the range,  $V_{SS} < (V_{IN} \text{ or } V_{OUT}) < V_{DD}$ . All digital inputs are tied high or low internally. Refers to electrical specifications for operating supply range.

**Table 5. Absolute Maximum Ratings**

Parameter	Description	Min.	Max.	Unit
$V_{DD}$	Operating Voltage	3.0	6.0	VDC
$V_{IRvss}$	Input, relative to $V_{SS}$	-0.3	$V_{DD} + 0.3$	VDC
$V_{ORvss}$	Output, relative to $V_{SS}$	-0.3	$V_{DD} + 0.3$	VDC
TOP	Temperature, Operating	0	+70	°C
TST	Temperature, Storage	-65	+150	°C
$T_J$	Temperature, Junction	-	+125	°C

**Table 6. DC Electrical Characteristics**  $V_{DD} = 3.3V$  and  $5.0V \pm 10\%$ ,  $X_{IN} = 48$  MHz,  $T_A = 0^\circ C$  to  $70^\circ C$ 

Parameter	Description	Min.	Typ.	Max.	Unit
$V_{IL}$	Input Low Voltage	-		$0.3 * V_{DD}$	VDC
$V_{IH}$	Input High Voltage	$0.7 * V_{DD}$			VDC
$I_{IL}$	Input Low Current			100	$\mu A$
$I_{IH}$	Input High Current			100	$\mu A$
$V_{OL}$	Output Low Voltage $I_{OL} = 10$ mA, $V_{DD} = 5V$			0.4	VDC
$V_{OH}$	Output High Voltage $I_{OH} = 10$ mA, $V_{DD} = 5V$	$V_{DD} - 1.0$			VDC
$V_{OL}$	Output Low Voltage $I_{OL} = 6$ mA, $V_{DD} = 3.3V$			0.4	VDC
$V_{OH}$	Output High Voltage $I_{OH} = 5$ mA, $V_{DD} = 3.3V$	2.4			VDC
Rpd	Resistor, Pull-down (Pin 7)	60K	125K	200K	$\Omega$
Rpu	Resistor, Pull-up (Pin 3)	60K	125K	200K	$\Omega$
$C_{xin}$	Input Capacitance (Pin 1)		8		pF
$C_{xout}$	Output Capacitance (Pin 2)		10		pF
$I_{CC}$	5V Dynamic Supply Current (CL = No Load)		38		mA
$I_{CC}$	3.3V Dynamic Supply Current (CL = No Load)		20		mA
ISC	Short Circuit Current (FSOUT)		25		mA
BW	BW% Variations, $3.30V^{[7]}$	-20	0	+20	%
BW	BW% Variations, $5.00V^{[7]}$	-30	0	+30	%

**Table 7. Timing Electrical Characteristics**  $V_{DD} = 3.3V$  and  $5.0V \pm 10\%$ ,  $T_A = 0^\circ C$  to  $70^\circ C$ ,  $C_L = 15$  pF,  $X_{IN} = 48$  MHz

Parameter	Description	Min.	Typ.	Max.	Unit
tTLH	Output Rise Time Measured at 10%–90% @ 5 VDC	1.8	2.2	2.7	ns
tTHL	Output Fall Time Measured at 10%–90% @ 5 VDC	1.5	2.0	2.5	ns
tTLH	Output Rise Time Measured at 0.8V–2.0V @ 5 VDC	0.5	0.65	0.8	ns
tTHL	Output Fall Time Measured at 0.8V–2.0 V @ 5 VDC	0.5	0.65	0.8	ns
tTLH	Output Rise Time Measured at 10%–90% @ 3.3 VDC	2.1	2.65	3.2	ns
tTHL	Output Fall Time Measured at 10%–90% @ 3.3 VDC	1.7	2.1	2.6	ns
tTLH	Output Rise Time Measured at 0.8V–2.0V @ 3.3 VDC	0.7	0.95	1.2	ns
tTHL	Output Fall Time Measured at 0.8V–2.0 V @ 3.3 VDC	0.6	0.85	1.1	ns
TsymF1	Output Duty Cycle	45	50	55	%

**Notes:**

6. **Single Power Supply:** The Voltage on any input or /O pin cannot exceed the power pin during power-up.
7. Percentage variations from the bandwidth % values given in *Table 2* and *Table 3*.



**Table 7. Timing Electrical Characteristics**  $V_{DD} = 3.3V$  and  $5.0V \pm 10\%$ ,  $T_A = 0^\circ C$  to  $70^\circ C$ ,  $C_L = 15$  pF,  $X_{IN} = 48$  MHz (continued)

Parameter	Description	Min.	Typ.	Max.	Unit
CCJ	FSOUT, Cycle-to-Cycle Jitter, 48 MHz @ 3.30 VDC (Pin 6)	–	320	370	ps
CCJ	FSOUT, Cycle-to-Cycle Jitter, 48 MHz @ 5.0 VDC (Pin 6)	–	310	360	ps
CCJ	FSOUT, Cycle-to-Cycle Jitter, 72 MHz @ 3.30 VDC (Pin 6)	–	270	325	ps
CCJ	FSOUT, Cycle-to-Cycle Jitter, 72 MHz @ 5.0 VDC (Pin 6)	–	390	440	ps

**Table 8. Range Selection Table**

S1 (pin 3)	S0 (pin 7)	Fin (MHz) (pin 2/3)	Modulation Rate	FS781 FSOUT (pin 6)	FS782 FSOUT (pin 6)	FS784 FSOUT (pin 6)
0	0	6–16	Fin/120	6–16 MHz	12–32 MHz	32–64 MHz
0	1	16–32	Fin/240	16–32 MHz	32–64 MHz	64–82 MHz
1	0	32–66	Fin/480	32–66 MHz	64–82 MHz	N/A
1	1	66–82	Fin/720	66–82 MHz	N/A	N/A

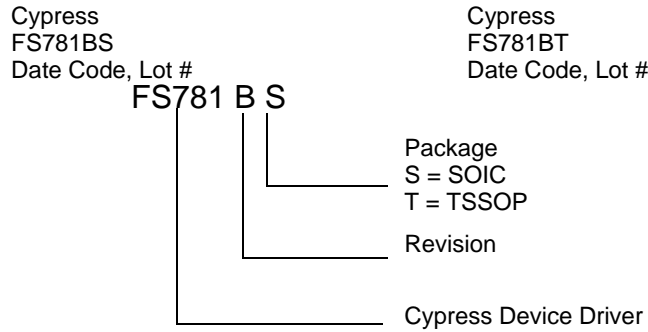
**Ordering Information<sup>[8]</sup>**

Part Number	Package Type	Product Flow
IMIFS781BZB	8-pin 150-mil SOIC	Commercial, 0 to 70°C
IMIFS781BZBT	8-pin 150-mil SOIC – Tape and Reel	Commercial, 0 to 70°C
IMIFS782BZB	8-pin 150-mil SOIC	Commercial, 0 to 70°C
IMIFS782BZBT	8-pin 150-mil SOIC – Tape and Reel	Commercial, 0 to 70°C
IMIFS784BZB	8-pin 150-mil SOIC	Commercial, 0 to 70°C
IMIFS784BZBT	8-pin 150-mil SOIC – Tape and Reel	Commercial, 0 to 70°C
IMIFS781BT	8-pin (4.4 mm body) TSSOP	Commercial, 0 to 70°C
IMIFS781BTT	8-pin (4.4 mm body) TSSOP – Tape and Reel	Commercial, 0 to 70°C
IMIFS784BT	8-pin (4.4 mm body) TSSOP	Commercial, 0 to 70°C
IMIFS784BTT	8-pin (4.4 mm body) TSSOP – Tape and Reel	Commercial, 0 to 70°C
<b>Lead-free</b>		
CYIFS781BSXC	8-pin 150-mil SOIC	Commercial, 0 to 70°C
CYIFS781BSXCT	8-pin 150-mil SOIC – Tape and Reel	Commercial, 0 to 70°C
CYIFS782BSXC	8-pin 150-mil SOIC	Commercial, 0 to 70°C
CYIFS782BSXCT	8-pin 150-mil SOIC – Tape and Reel	Commercial, 0 to 70°C
CYIFS784BSXC	8-pin 150-mil SOIC	Commercial, 0 to 70°C
CYIFS784BSXCT	8-pin 150-mil SOIC – Tape and Reel	Commercial, 0 to 70°C
CYIFS781BZXC	8-pin (4.4 mm body) TSSOP	Commercial, 0 to 70°C
CYIFS781BZXCT	8-pin (4.4 mm body) TSSOP – Tape and Reel	Commercial, 0 to 70°C
CYIFS782BZXC	8-pin (4.4 mm body) TSSOP	Commercial, 0 to 70°C
CYIFS782BZXCT	8-pin (4.4 mm body) TSSOP – Tape and Reel	Commercial, 0 to 70°C
CYIFS784BZXC	8-pin (4.4 mm body) TSSOP	Commercial, 0 to 70°C
CYIFS784BZXCT	8-pin (4.4 mm body) TSSOP – Tape and Reel	Commercial, 0 to 70°C

**Note:**

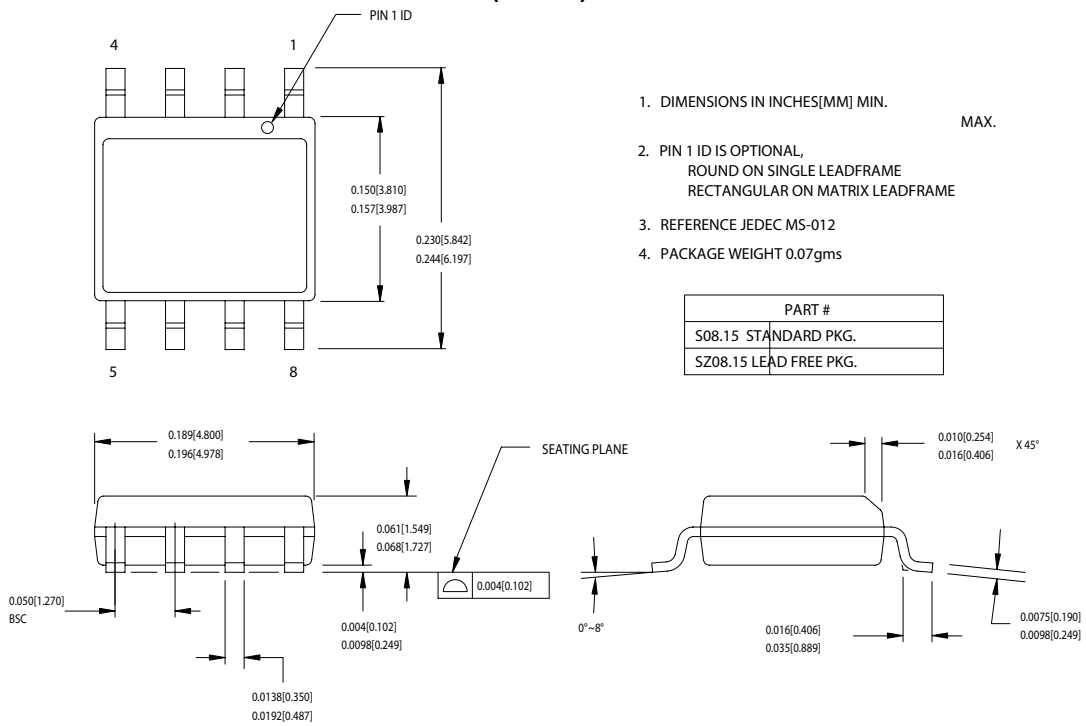
8. The ordering part number differs from the marking on the actual device.

**Marking Example**



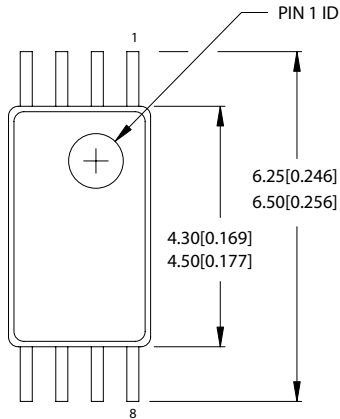
**Package Drawing and Dimensions**

**8-lead (150-Mil) SOIC S8**

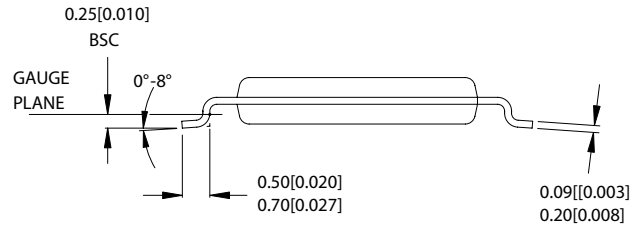
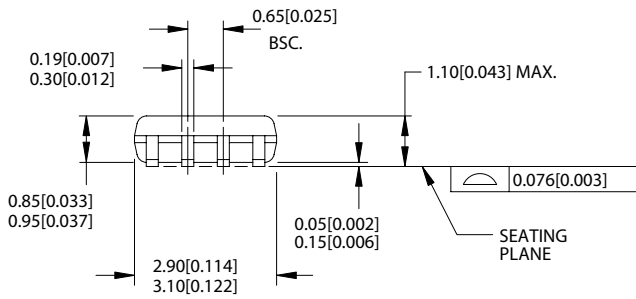


**Package Drawing and Dimensions** (continued)

**8-Lead Thin Shrunk Small Outline Package (4.40 MM Body) Z8**



DIMENSIONS IN MM[INCHES] MIN.  
MAX.



51-85093-\*A

All product and company names mentioned in this document may be the trademarks of their respective holders.

**Document History Page**

Document Title: FS781/82/84 Low EMI Spectrum Spread Clock				
Document Number: 38-07029				
REV.	ECN NO.	Issue Date	Orig. of Change	Description of Change
**	106948	06/07/01	IKA	Convert from IMI to Cypress
*A	111654	02/27/02	IKL	Add new marking suffix for SOIC packages. Converted to FrameMaker.
*B	118355	08/30/02	RGL	Swap the location of S0 and S1 in tables 2 and 3 in pages 2,3 and 4.
*C	122679	12/14/02	RBI	Add power up requirements to operating conditions information.
*D	277189	See ECN	RGL	Added Lead-free Devices
*E	314274	See ECN	RGL	Fixed the Ordering Information to match the DevMaster
*F	417662	See ECN	RGL	Added Maximum Junction Temperature in Absolute Maximum Ratings table

## X-ON Electronics

Largest Supplier of Electrical and Electronic Components

*Click to view similar products for [Phase Locked Loops - PLL category](#):*

*Click to view products by [Cypress manufacturer](#):*

Other Similar products are found below :

[HMC700LP4TR](#) [CPLL58-2400-2500](#) [MB15E07SLPFV1-G-BND-6E1](#) [PI6C2409-1HWEX](#) [BA4116FV-E2](#) [HMC820LP6CETR](#)  
[HMC828LP6CETR](#) [LMX2430TMX/NOPB](#) [HMC837LP6CETR](#) [HMC831LP6CETR](#) [NB3N5573DTG](#) [ADF4153ABCPZ](#) [PI6C2405A-1LE](#)  
[CD74HC4046AM](#) [CPLL66-2450-2450](#) [NJM567D](#) [74HC4046ADB.112](#) [74HC4046APW.112](#) [CY23S05SXI-1](#) [STW81200T](#) [ADF4208BRUZ](#)  
[ADF4218LBRUZ](#) [ADF4355-3BCPZ](#) [ADF5355BCPZ](#) [ADF4355BCPZ](#) [ADF4169WCCPZ](#) [ADF4360-7BCPZ](#) [ADF4360-6BCPZ](#) [ADF4360-](#)  
[5BCPZRL7](#) [ADF4360-5BCPZ](#) [ADF4360-4BCPZRL7](#) [ADF4360-4BCPZ](#) [ADF4360-3BCPZ](#) [ADF4360-2BCPZRL7](#) [ADF4252BCPZ](#)  
[ADF4159CCPZ](#) [ADF4169CCPZ](#) [ADF4252BCPZ-R7](#) [ADF4360-0BCPZ](#) [ADF4360-1BCPZ](#) [ADF4360-1BCPZRL7](#) [ADF4360-2BCPZ](#)  
[ADF4360-3BCPZRL7](#) [ADF4360-7BCPZRL7](#) [ADF4360-8BCPZ](#) [ADF4360-8BCPZRL7](#) [ADF4360-9BCPZ](#) [ADF4360-9BCPZRL7](#)  
[ADF4159CCPZ-RL7](#) [ADF4159WCCPZ](#)