



Single-Chip Bluetooth Transceiver for Wireless Input Devices

The Cypress CYW20735 is a Bluetooth 4.2-compliant, stand-alone baseband processor with an integrated 2.4 GHz transceiver. Manufactured using the industry's advanced 40 nm CMOS low-power process, the CYW20735 employs high levels of integration to minimize external components, reducing the device footprint and the costs associated with implementing Bluetooth solutions.

The CYW20735 is the optimal solution for applications in wireless input devices including game controllers, remote controls, keyboards, and joysticks.

Built-in firmware adheres to the Bluetooth Low Energy (BLE) profile and the BLE Human Interface Device (HID) profile.

Cypress Part Numbering Scheme

Cypress is converting the acquired IoT part numbers from Cypress to the Cypress part numbering scheme. Due to this conversion, there is no change in form, fit, or function as a result of offering the device with Cypress part number marking. The table provides Cypress ordering part number that matches an existing IoT part number.

Table 1. Mapping Table for Part Number between Broadcom and Cypress

Broadcom Part Number	Cypress Part Number
BCM20735	CYW20735
BCM20735PKML1G	CYW20735PKML1G
BCM20735KFBG	CYW20735KFBG

Features

- Complies with Bluetooth Core Specification version 4.2 including Basic Rate (BR) BR/LE
- Supports Cypress proprietary data rate up to 2 Mbps
- BLE HID profile version 1.00 compliant
- Bluetooth Device ID profile version 1.3 compliant
- Supports Generic Access Profile (GAP)
- Supports Adaptive Frequency Hopping (AFH)
- Excellent receiver sensitivity
- Programmable output power control
- Integrated ARM Cortex-M4 microprocessor core floating point unit (FPU)
- On-chip power-on reset (POR)
- Support for serial flash devices
- Integrated buck and low dropout (LDO) regulators
- On-chip software controlled power management unit
- Programmable key scan matrix interface, up to 8 × 20 key-scanning matrix
- Three-axis quadrature signal decoder
- Infrared modulator
- IR learning
- Auxiliary ADC with up to 28 analog channels
- On-chip support for serial peripheral interface (SPI) (master and slave modes)
- Cypress Serial Communications (BSC) interface (compatible with NXP I²C slaves)
- LE packet extension
- Timed wakeup
- Wireless charging interface
- Package types:
 - 60-pin quad flat no-lead (QFN)
 - 111-pin fine pitch ball grid array (FBGA)
 - RoHS compliant

Applications

- Game controllers
- Wireless pointing devices (mice)
- Remote controls
- Wireless keyboards
- Joysticks
- Home automation
- Point-of-sale input devices
- 3D glasses
- Blood pressure monitors
- Find-me devices
- Heart-rate monitors
- Proximity sensors
- Thermometers

Figure 1. Functional Block Diagram

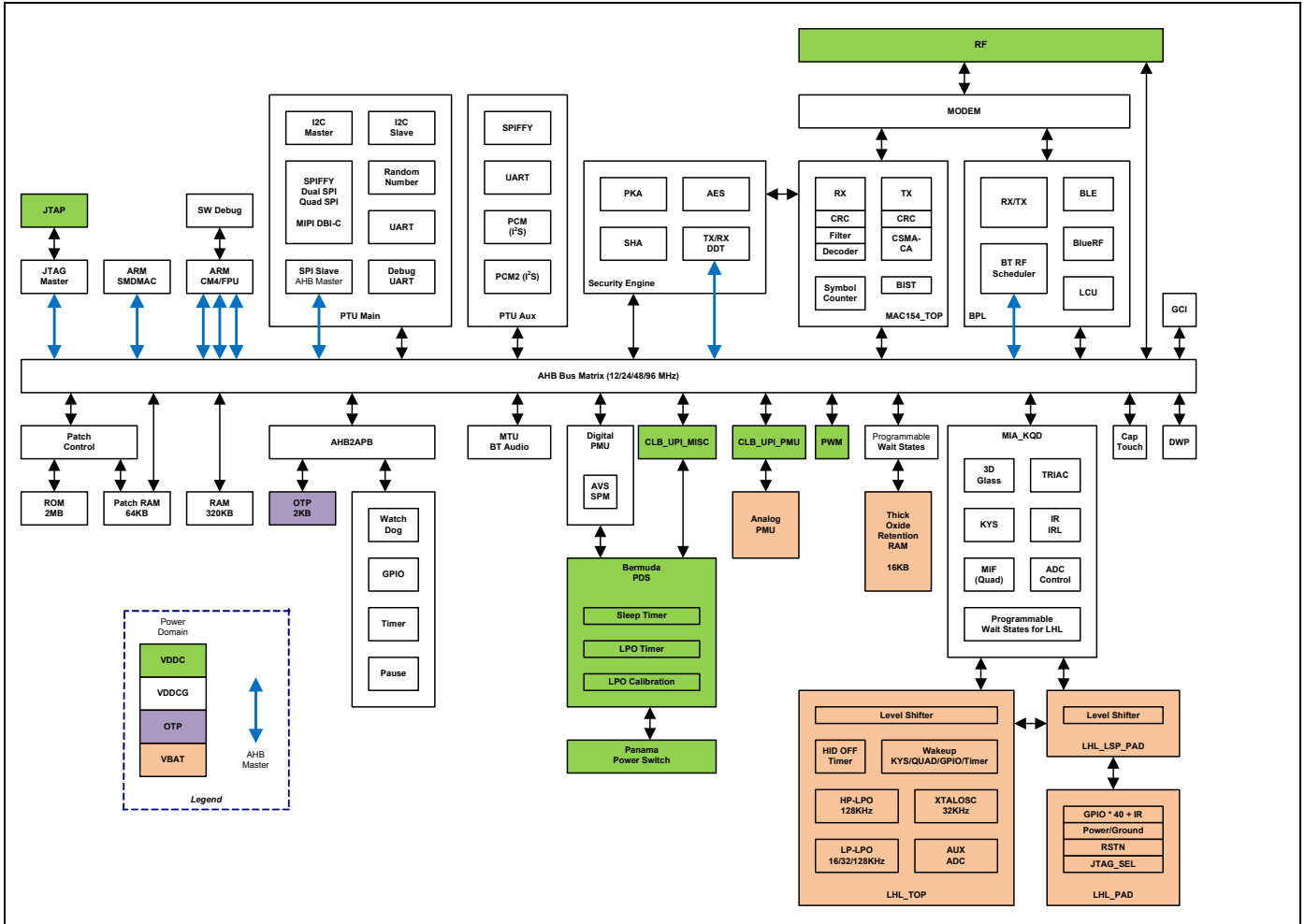

Contents

1. Functional Description	4	1.19 Security Engine	17
1.1 Bluetooth Baseband Core	4	1.20 Power Management Unit	17
1.2 Microprocessor Unit	6	2. Pin Assignments and GPIOs	18
1.3 Power Management Unit	8	2.1 Pin Assignments	18
1.4 Integrated Radio Transceiver	8	2.2 GPIO Pin Descriptions	21
1.5 Peripheral Transport Unit	9	2.3 Ball Maps	30
1.6 UART Interface	10	3. Specifications	32
1.7 Peripheral UART Interface	10	3.1 Electrical Characteristics	32
1.8 Clock Frequencies	11	3.4 Timing and AC Characteristics	42
1.9 GPIO Ports	12	4. Mechanical Information	48
1.10 Keyboard Scanner	13	4.1 Package Diagrams	48
1.11 Mouse Quadrature Signal Decoder	14	4.2 Tray Packaging Specifications	50
1.12 ADC Port	14	5. Ordering Information	53
1.13 PWM	15	6. Additional Information	53
1.14 Triac Control	15	6.1 IoT Resources	53
1.15 Serial Peripheral Interface	15	6.2 Acronyms and Abbreviations	53
1.16 Infrared Modulator	16	Document History Page	55
1.17 Infrared Learning	16	Sales, Solutions, and Legal Information	56
1.18 PDM Microphone	16		

1. Functional Description

1.1 Bluetooth Baseband Core

The Bluetooth Baseband Core (BBC) implements all of the time-critical functions required for high-performance Bluetooth operation. The BBC manages the buffering, segmentation, and routing of data for all connections. It also buffers data that passes through it, handles data flow control, schedules SCO/ACL and TX/RX transactions, monitors Bluetooth slot usage, optimally segments and packages data into baseband packets, manages connection status indicators, and composes and decodes HCI packets. In addition to these functions, it independently handles HCI event types, and HCI command types.

The following transmit and receive functions are also implemented in the BBC hardware to increase reliability and security of the TX/RX data before sending over the air:

- Symbol timing recovery, data deframing, forward error correction (FEC), header error control (HEC), cyclic redundancy check (CRC), data decryption, and data dewatering in the receiver.
- Data framing, FEC generation, HEC generation, CRC generation, key generation, data encryption, and data whitening in the transmitter.

1.1.1 Bluetooth 4.2 Features

The CYW20735 supports the following Bluetooth v4.2 features:

- LE data packet length extension
- LE secure connections
- Link layer privacy

1.1.2 Bluetooth 4.1 Features

The CYW20735 supports the following Bluetooth v4.1 features:

- Secure connections for BR
- Fast advertising interval
- Piconet clock adjust
- Connectionless broadcast
- LE privacy v1.1
- Low duty cycle directed advertising
- LE dual-mode topology

1.1.3 Bluetooth 4.0 Features

The BBC supports all Bluetooth 4.0 features, with the following benefits:

- Dual-mode Bluetooth low energy (BT and BLE operation)
- Extended inquiry response (EIR): Shortens the time to retrieve the device name, specific profile, and operating mode.
- Encryption pause resume (EPR): Enables the use of Bluetooth technology in a much more secure environment.
- Sniff subrating (SSR): Optimizes power consumption for low duty cycle asymmetric data flow, which subsequently extends battery life.
- Secure simple pairing (SSP): Reduces the number of steps for connecting two devices, with minimal or no user interaction required.
- Link supervision timeout (LSTO): Additional commands added to HCI and Link Management Protocol (LMP) for improved link timeout supervision.
- Quality of service (QoS) enhancements: Changes to data traffic control, which results in better link performance. Audio, human interface device (HID), bulk traffic, SCO, and enhanced SCO (eSCO) are improved with the erroneous data (ED) and packet boundary flag (PBF) enhancements.

1.1.4 Link Control Layer

The link control layer is part of the Bluetooth link control functions that are implemented in dedicated logic in the link control unit (LCU). This layer consists of the command controller that takes commands from the software, and other controllers that are activated or configured by the command controller, to perform the link control tasks. Each task is performed in a different state or substate in the Bluetooth Link Controller.

- BLE states:
 - Advertising
 - Scanning
 - Connection
- Major states:
 - Standby
 - Connection
- Substates:
 - Page
 - Page Scan
 - Inquiry
 - Inquiry Scan
 - Sniff

1.1.5 Test Mode Support

The CYW20735 fully supports Bluetooth Test mode as described in Part I:1 of the Specification of the Bluetooth System Version 3.0. This includes the transmitter tests, normal and delayed loopback tests, and reduced hopping sequence.

In addition to the standard Bluetooth Test Mode, the CYW20735 also supports enhanced testing features to simplify RF debugging and qualification and type-approval testing. These features include:

- Fixed frequency carrier wave (unmodulated) transmission
 - Simplifies some type-approval measurements (Japan)
 - Aids in transmitter performance analysis
- Fixed frequency constant receiver mode
 - Receiver output directed to I/O pin
 - Allows for direct BER measurements using standard RF test equipment
 - Facilitates spurious emissions testing for receive mode
- Fixed frequency constant transmission
 - 8-bit fixed pattern or PRBS-9
 - Enables modulated signal measurements with standard RF test equipment

1.1.6 Frequency Hopping Generator

The frequency hopping sequence generator selects the correct hopping channel number based on the link controller state, Bluetooth clock, and device address.

1.2 Microprocessor Unit

The CYW20735 microprocessor unit runs software from the link control (LC) layer up to the host controller interface (HCI). The microprocessor is a Cortex-M4 32-bit RISC processor with embedded ICE-RT debug and serial wire debug (SWD) interface units. The microprocessor also includes 2 MB of ROM memory for program storage and 384 KB of RAM for data scratch-pad.

The internal ROM provides flexibility during power-on reset to enable the same device to be used in various configurations. At power-up, the lower-layer protocol stack is executed from internal ROM.

External patches can be applied to the ROM-based firmware to provide flexibility for bug fixes and feature additions. The device also supports the integration of user applications and profiles.

1.2.1 Floating Point Unit

CYW20735 includes the CM4 single precision IEEE-754 compliant floating point unit. For details see the Cortex-M4 manual.

1.2.2 OTP Memory

The CYW20735 includes 2 KB of one-time programmable memory that can be used by the factory to store product-specific information.

Note: Use of OTP requires that a 3V supply be present at all times.

1.2.3 NVRAM Configuration Data and Storage

NVRAM contains configuration information about the customer application, including the following:

- Fractional-N information
- BD_ADDR
- UART baud rate
- SDP service record
- File system information used for code, code patches, or data. The CYW20735 uses SPI flash for NVRAM storage.

1.2.4 Power-On Reset

The CYW20735 includes POR logic to allow the part to initialize correctly when power is applied. [Figure 1](#) shows the sequence used by the CYW20735 during initialization. An small external cap may be used on RESET_N to add delay as VDDIO ramps up.

1.2.5 External Reset

An external active-low reset signal, RESET_N, can be used to put the CYW20735 in the reset state.

Figure 1. Power-On Reset Timing

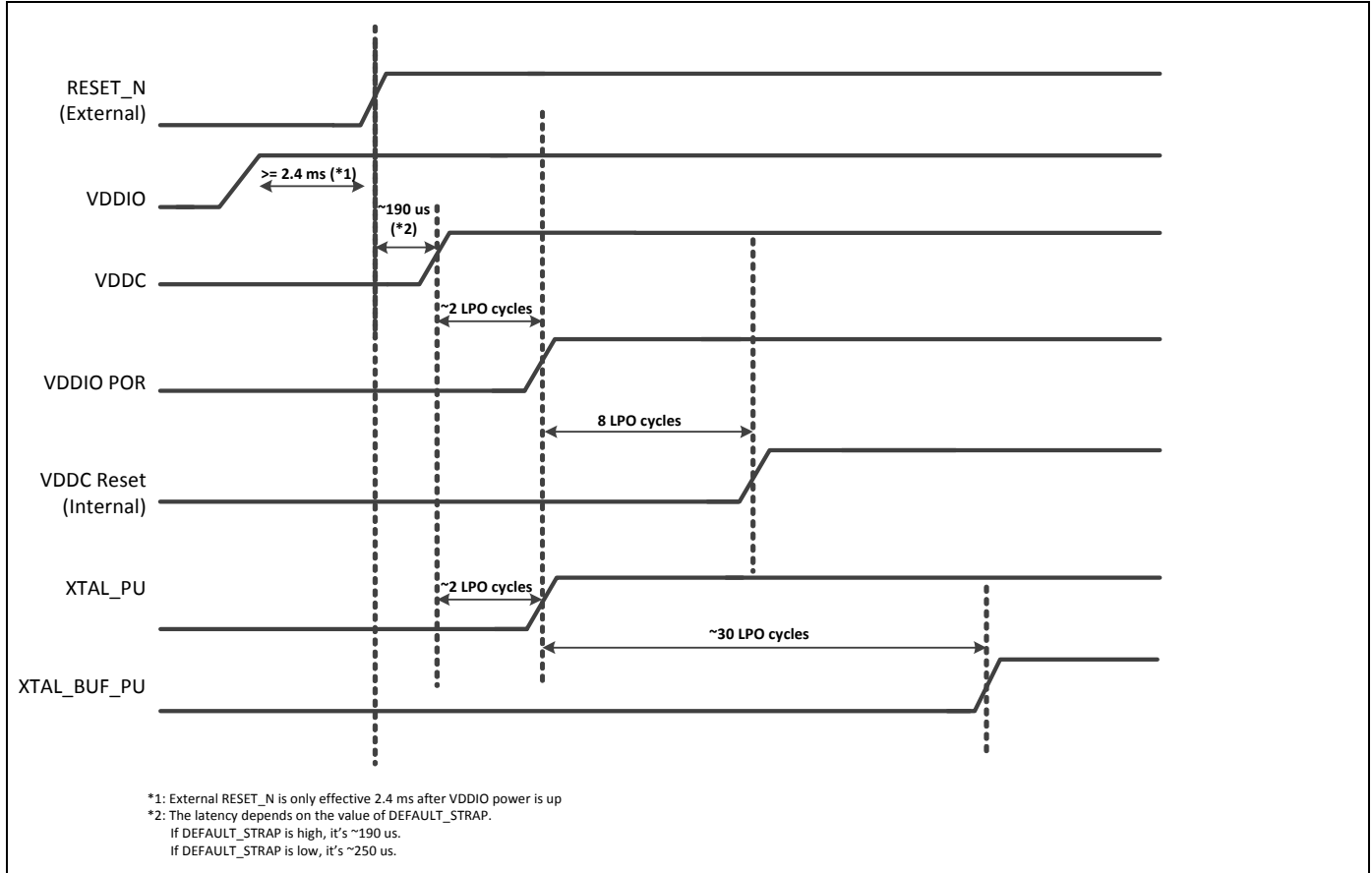

1.2.6 Brownout Detection

An external voltage detector reset IC may be used if brownout detection is required. The reset IC should release RESET_N only after the VDDO supply voltage level has been at or above a minimum operating voltage for 50 ms or longer.

1.3 Power Management Unit

Figure 2 shows the CYW20735 power management unit (PMU) block diagram. The CYW20735 includes an integrated buck regulator, a capless LDO, PALDO and an additional 1.2V LDO for RF.

Figure 2. Power Management Unit

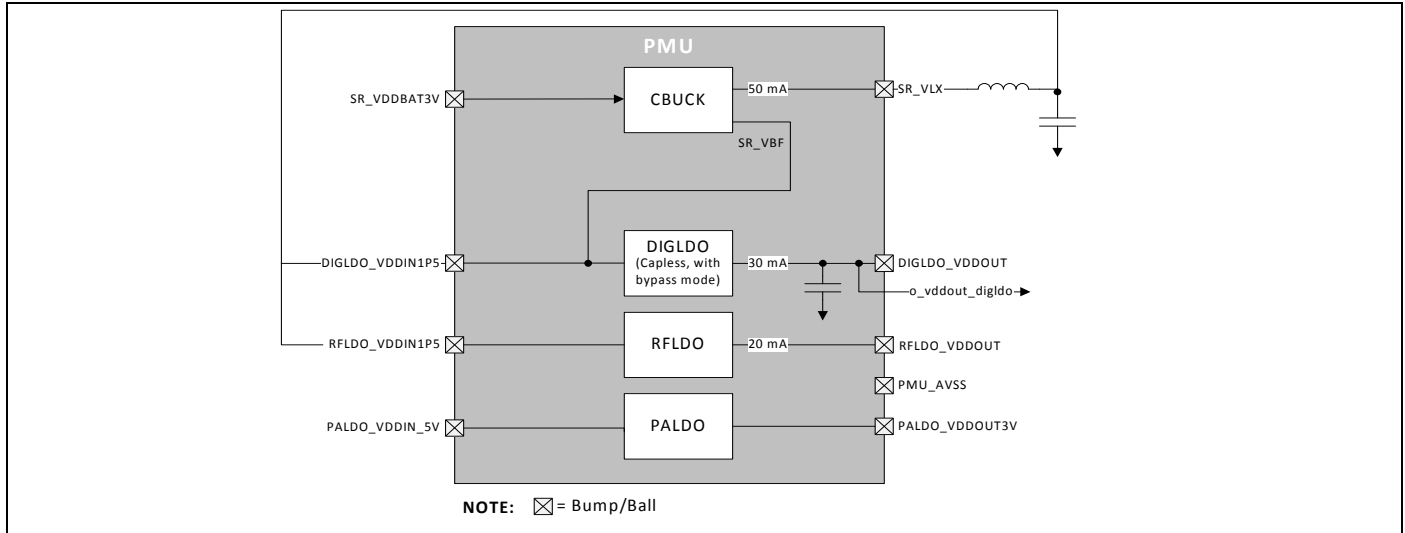

1.4 Integrated Radio Transceiver

The CYW20735 has an integrated radio transceiver that has been optimized for use in 2.4 GHz Bluetooth wireless systems. It has been designed to provide low-power, low-cost, robust communications for applications operating in the globally available 2.4 GHz unlicensed ISM band. The CYW20735 is fully compliant with the Bluetooth Radio Specification and meets or exceeds the requirements to provide the highest communication link quality of service.

1.4.1 Transmit Path

The CYW20735 features a fully integrated transmitter. The baseband transmit data is GFSK modulated in the 2.4 GHz ISM band.

1.4.2 Digital Modulator

The digital modulator performs the data modulation and filtering required for the GFSK signal. The fully digital modulator minimizes any frequency drift or anomalies in the modulation characteristics of the transmitted signal.

1.4.3 Power Amplifier

The CYW20735 has an integrated power amplifier (PA) that can transmit up to +10 dBm for class 1 operations.

1.4.4 Receiver Path

The receiver path uses a low-IF scheme to downconvert the received signal for demodulation in the digital demodulator and bit synchronizer. The receiver path provides a high degree of linearity, an extended dynamic range to ensure reliable operation in the noisy 2.4 GHz ISM band. The front-end topology, with built-in out-of-band attenuation, enables the CYW20735 to be used in most applications with minimal off-chip filtering.

1.4.5 Digital Demodulator and Bit Synchronizer

The digital demodulator and bit synchronizer takes the low-IF received signal and performs an optimal frequency tracking and bit-synchronization algorithm.

1.4.6 Receiver Signal Strength Indicator

The radio portion of the CYW20735 provides a receiver signal strength indicator (RSSI) signal to the baseband, so that the controller can take part in a Bluetooth power-controlled link by providing a metric of its own receiver signal strength to determine whether the transmitter should increase or decrease its output power.

1.4.7 Local Oscillator

A local oscillator (LO) generation provides fast frequency hopping (1600 hops/second) across the 79 maximum available channels. The CYW20735 uses an internal loop filter.

1.4.8 Calibration

The CYW20735 radio transceiver features a self-contained automated calibration scheme. No user interaction is required during normal operation or during manufacturing to provide optimal performance. Calibration compensates for filter, matching network, and amplifier gain and phase characteristics to yield radio performance within 2% of what is optimal. Calibration takes process and temperature variations into account, and it occurs transparently during normal operation and hop setting times.

1.5 Peripheral Transport Unit

1.5.1 Cypress Serial Communications Interface

The CYW20735 provides a 2-pin master BSC to communicate with peripherals such as trackball or touch-pad modules, and motion tracking ICs used in mouse devices. The BSC interface is compatible with I²C slave devices. BSC does not support multimaster capability or flexible wait-state insertion by either master or slave devices.

The following transfer clock rates are supported by BSC:

- 100 kHz
- 400 kHz
- 800 kHz (Not a standard I²C-compatible speed.)
- 1 MHz (Compatibility with high-speed I²C-compatible devices is not guaranteed.)

The following transfer types are supported by BSC:

- Read (Up to 8 bytes can be read.)
- Write (Up to 8 bytes can be written.)
- Read-then-Write (Up to 8 bytes can be read and up to 8 bytes can be written.)
- Write-then-Read (Up to 8 bytes can be written and up to 8 bytes can be read.)

Hardware controls the transfers, requiring minimal firmware setup and supervision.

The clock pin (SCL) and data pin (SDA) are both open-drain I/O pins. Pull-up resistors external to the CYW20735 are required on both the SCL and SDA pins for proper operation.

1.6 UART Interface

The CYW20735 includes a UART interface for factory programming and when operating as a BT HCI device in a system with an external host. The UART physical interface is a standard, 4-wire interface (RX, TX, RTS, and CTS) with adjustable baud rates from 57600 bps to 6 Mbps. During initial boot, UART speeds may be limited to 750 kbps. The baud rate may be selected via a vendor-specific UART HCI command. The CYW20735 has a 1040-byte receive FIFO and a 1040-byte transmit FIFO to support enhanced data rates. The interface supports the Bluetooth UART HCI (H4) specification. The default baud rate for H4 is 115.2 kbaud.

The UART clock default setting is 24 MHz, and can be configured to run as high as 48 MHz to support up to 6 Mbps. The baud rate of the CYW20735 UART is controlled by two values. The first is a UART clock divisor (set in the DLBR register) that divides the UART clock by an integer multiple of 16. The second is a baud rate adjustment (set in the DHBR register) that is used to specify a number of UART clock cycles to stuff in the first or second half of each bit time. Up to eight UART cycles can be inserted into the first half of each bit time, and up to eight UART clock cycles can be inserted into the end of each bit time.

Table 2 on page 10 contains example values to generate common baud rates with a 24 MHz UART clock.

Table 2. Common Baud Rate Examples, 24 MHz Clock

Baud Rate (bps)	Baud Rate Adjustment		Mode	Error (%)
	High Nibble	Low Nibble		
3M	0xFF	0xF8	High rate	0.00
2M	0xFF	0xF4	High rate	0.00
1M	0X44	0XFF	Normal	0.00
921600	0x05	0x05	Normal	0.16
460800	0x02	0x02	Normal	0.16
230400	0x04	0x04	Normal	0.16
115200	0x00	0x00	Normal	0.16
57600	0x00	0x00	Normal	0.16

Table 3 contains example values to generate common baud rates with a 48 MHz UART clock.

Table 3. Common Baud Rate Examples, 48 MHz Clock

Baud Rate (bps)	High Rate	Low Rate	Mode	Error (%)
6M	0xFF	0xF8	High rate	0
4M	0xFF	0xF4	High rate	0
3M	0x0	0xFF	Normal	0
2M	0x44	0xFF	Normal	0
1.5M	0x0	0xFE	Normal	0
1M	0x0	0xFD	Normal	0
921600	0x22	0xFD	Normal	0.16
230400	0x0	0xF3	Normal	0.16
115200	0x1	0xE6	Normal	-0.08
57600	0x1	0xCC	Normal	0.04

Support for changing the baud rate during normal HCI UART operation is included through a vendor-specific command that allows the host to adjust the contents of the baud rate registers.

The CYW20735 UART operates correctly with the host UART as long as the combined baud rate error of the two devices is within $\pm 5\%$.

1.7 Peripheral UART Interface

The CYW20735 has a second UART that may be used to interface to peripherals. This peripheral UART is accessed through the optional I/O ports, which can be configured individually and separately for each functional pin. The CYW20735 can map the peripheral UART to any LHL GPIO. The peripheral UART clock is fixed at 24 MHz. Both TX and RX have a 256-byte FIFO (see Table 2: “Common Baud Rate Examples, 24 MHz Clock,” on page 11).

1.8 Clock Frequencies

The CYW20735 uses a 24 MHz crystal oscillator (XTAL).

1.8.1 Crystal Oscillator

The XTAL must have an accuracy of ± 20 ppm as defined by the Bluetooth specification. Two external load capacitors in the range of 5 pF to 30 pF are required to work with the crystal oscillator. The selection of the load capacitors is XTAL-dependent (see [Figure 3](#)).

Figure 3. Recommended Oscillator Configuration—12 pF Load Crystal

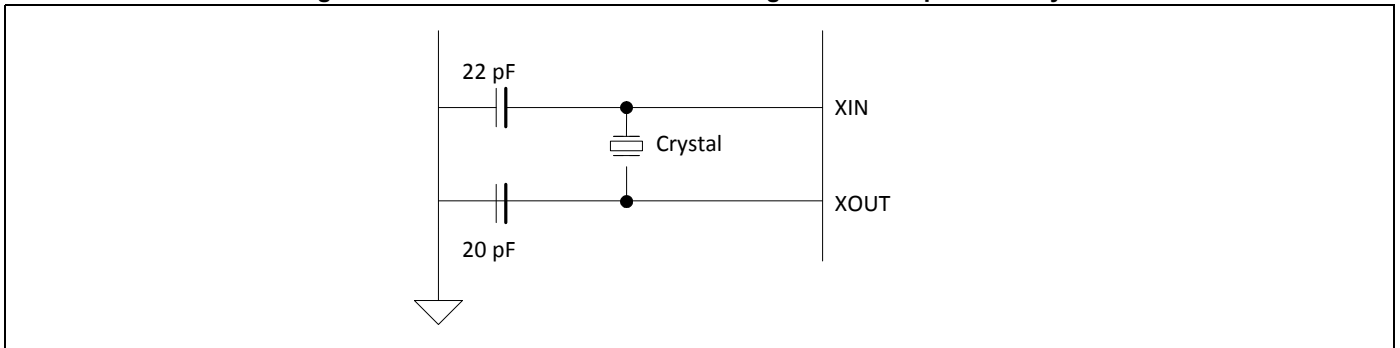

[Table 4](#) shows the recommended crystal specifications.

Table 4. Reference Crystal Electrical Specifications

Parameter	Conditions	Minimum	Typical	Maximum	Unit
Nominal frequency	–	–	24.000	–	MHz
Oscillation mode	–	Fundamental			–
Frequency tolerance	@25°C	–	± 10	–	ppm
Tolerance stability over temp	@0°C to +70°C	–	± 10	–	ppm
Equivalent series resistance	–	–	–	60	Ω
Load capacitance	–	–	10	–	pF
Operating temperature range	–	0	–	+70	°C
Storage temperature range	–	–40	–	+125	°C
Drive level	–	–	–	200	μW
Aging	–	–	± 3	± 10	ppm/year
Shunt capacitance	–	–	–	2	pF

1.8.2 HID Peripheral Block

The peripheral blocks of the CYW20735 all run from a single 128 kHz low-power RC oscillator. The oscillator can be turned on at the request of any of the peripherals. If the peripheral is not enabled, it shall not assert its clock request line.

The keyboard scanner is a special case, in that it may drop its clock request line even when enabled, and then reassert the clock request line if a keypress is detected.

1.8.3 32 kHz Crystal Oscillator

Figure 4 shows the 32 kHz XTAL oscillator with external components and Table on page 12 lists the oscillator’s characteristics. It is a standard Pierce oscillator using a comparator with hysteresis on the output to create a single-ended digital output. The hysteresis was added to eliminate any chatter when the input is around the threshold of the comparator and is ~100 mV. This circuit can be operated with a 32 kHz or 32.768 kHz crystal oscillator or be driven with a clock input at a similar frequency. The default component values are: R1 = 10 MΩ and C1 = C2 = ~10 pF. The values of C1 and C2 are used to fine-tune the oscillator.

Figure 4. 32 kHz Oscillator Block Diagram

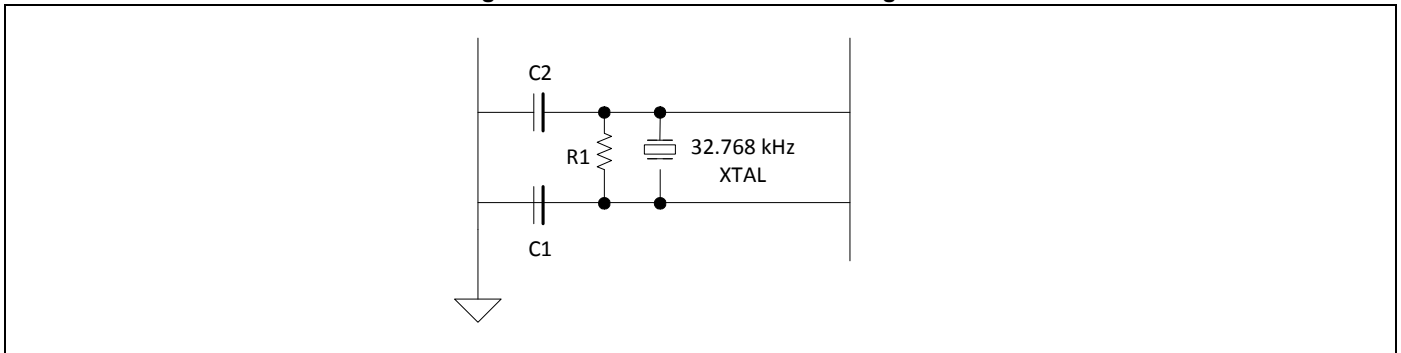

Table 5. XTAL Oscillator Characteristics

Parameter	Symbol	Conditions	Minimum	Typical	Maximum	Unit
Output frequency	F_{oscout}	–	–	32.768	–	kHz
Frequency tolerance	–	Crystal-dependent	–	100	–	ppm
Start-up time	$T_{startup}$	–	–	–	500	ms
XTAL drive level	P_{drv}	For crystal selection	0.5	–	–	μW
XTAL series resistance	R_{series}	For crystal selection	–	–	70	kΩ
XTAL shunt capacitance	C_{shunt}	For crystal selection	–	–	1.3	pF

1.9 GPIO Ports

1.9.1 60-Pin QFN Package

The 60-pin QFN package GPIO ports are shown in Table 7 on page 21.

1.9.2 111-Pin FBGA Package

The 111-pin FBGA package GPIO ports are also shown in Table 7 on page 21.

The CYW20735 uses 40 general-purpose I/Os (GPIOs) in the 111-pin FBGA package. All GPIOs support programmable pull-ups and are capable of driving up to 8 mA at 3.3V or 4 mA at 1.8V, except P26, P27, P28, and P29, which are capable of driving up to 16 mA at 3.3V or 8 mA at 1.8V.

P0, P1, P8-P19, P21-23, P28-P38: all of these pins can be programmed as ADC inputs.

Port 26–Port 29: all four of these pins are capable of sinking up to 16 mA for LEDs. These pins also have the PWM function, which can be used for LED dimming.

1.10 Keyboard Scanner

The keyboard scanner is designed to autonomously sample keys and store them into buffer registers without the need for the host microcontroller to intervene. The scanner has the following features:

- Ability to turn off its clock if no keys are pressed.
- Sequential scanning of up to 160 keys in an 8 × 20 matrix.
- Programmable number of columns from 1 to 20.
- Programmable number of rows from 1 to 8.
- 16-byte key code buffer (can be augmented by firmware).
- 128 kHz clock that allows scanning of full 160-key matrix in about 1.2 ms.
- N-key rollover with selective 2-key lockout if ghost is detected.
- Keys are buffered until host microcontroller has a chance to read it, or until overflow occurs.
- Hardware debouncing and noise/glitch filtering.
- Low-power consumption. Single-digit μ A-level sleep current.

1.10.1 Theory of Operation

The key scan block is controlled by a state machine with the following states:

1.10.2 Idle

The state machine begins in the idle state. In this state, all column outputs are driven high. If any key is pressed, a transition occurs on one of the row inputs. This transition causes the 128 kHz clock to be enabled (if it is not already enabled by another peripheral) and the state machine to enter the scan state. Also in this state, an 8-bit row-hit register and an 8-bit key-index counter is reset to 0.

1.10.3 Scan

In the scan state, a row counter counts from 0 up to a programmable number of rows minus 1. After the last row is reached, the row counter is reset and the column counter is incremented. This cycle repeats until the row and column counters are both at their respective terminal count values. At that point, the state machine moves into the Scan-End state.

As the keys are being scanned, the key-index counter is incremented. This counter value is compared to the modifier key codes stored in RAM, or in the key code buffer if the key is not a modifier key. It can be used by the microprocessor as an index into a lookup table of usage codes.

Also, as the n th row is scanned, the row-hit register is ORed with the current 8-bit row input values if the current column contains two or more row hits. During the scan of any column, if a key is detected at the current row, and the row-hit register indicates that a hit was detected in that same row on a previous column, then a ghost condition may have occurred, and a bit in the status register is set to indicate this.

1.10.4 Scan End

This state determines whether any keys were detected while in the scan state. If yes, the state machine returns to the scan state. If no, the state machine returns to the idle state, and the 128 kHz clock request signal is made inactive.

Note: The microcontroller can poll the key status register.

1.11 Mouse Quadrature Signal Decoder

The mouse signal decoder is designed to autonomously sample two quadrature signals commonly generated by an optomechanical mouse. The decoder has the following features:

- Three pairs of inputs for X, Y, and Z (typical scroll wheel) axis signals. Each axis has two options:
 - For the X axis, choose P2 or P32 as X0 and P3 or P33 as X1.
 - For the Y axis, choose P4 or P34 as Y0 and P5 or P35 as Y1.
 - For the Z axis, choose P6 or P36 as Z0 and P7 or P37 as Z1.
- Control of up to four external high-current GPIOs to power external optoelectronics:
 - Turn-on and turn-off time can be staggered for each HC-GPIO to avoid simultaneous switching of high currents and having multiple high-current devices on at the same time.
 - Sample time can be staggered for each axis.
 - Sense of the control signal can be active high or active low.
 - Control signal can be tristated for off condition or driven high or low, as appropriate.

1.11.1 Theory of Operation

The mouse decoder block has four 10-bit PWMs for controlling external quadrature devices and sampling the quadrature inputs at its core.

The GPIO signals may be used to control such items as LEDs, external ICs that may emulate quadrature signals, photodiodes, and photodetectors.

1.12 ADC Port

The ADC block is a single switched-cap Σ - Δ ADC core for audio and DC measurement. It operates at the 12 MHz clock rate and has 32 DC input channels, including 28 GPIO inputs. The internal bandgap reference has $\pm 5\%$ accuracy without calibration. Different calibration and digital correction schemes can be applied to reduce ADC absolute error and improve measurement accuracy in DC mode.

1.13 PWM

The CYW20735 has six internal PWMs. The PWM module consists of the following:

- PWM0–5. Each of the six PWM channels contains the following registers:
 - 16-bit initial value register (read/write)
 - 16-bit toggle register (read/write)
 - 16-bit PWM counter value register (read)
- PWM configuration register shared among PWM0–5 (read/write). This 18-bit register is used:
 - To configure each PWM channel
 - To select the clock of each PWM channel
 - To change the phase of each PWM channel

Figure 5 shows the structure of one PWM.

Figure 5. PWM Block Diagram

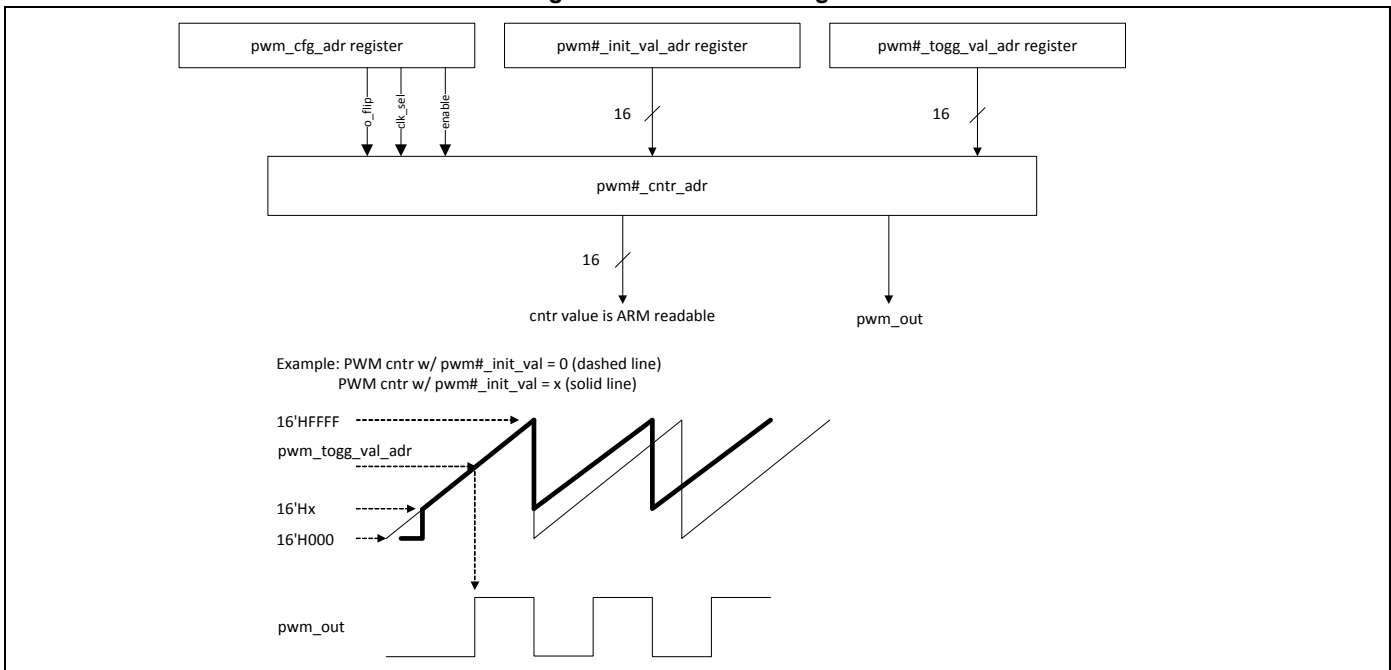

1.14 Triac Control

The CYW20735 includes hardware support for zero-crossing detection and trigger control for up to four triacs. The CYW20735 detects zero-crossing on the AC zero detection line and uses that to provide a pulse that is offset from the zero crossing. This allows the CYW20735 to be used in dimmer applications, as well as any other applications that require a control signal that is offset from an input event.

The zero-crossing hardware includes an option to suppress glitches.

1.15 Serial Peripheral Interface

The CYW20735 has two independent SPI interfaces, both of which support single, dual, and quad mode SPI operations.

Either interface can be a master or a slave. Each interface has a 64-byte transmit buffer and a 64-byte receive buffer. To support more flexibility for user applications, the CYW20735 has optional I/O ports that can be configured individually and separately for each functional pin. The CYW20735 acts as an SPI master device that supports 1.8V or 3.3V SPI slaves. The CYW20735 can also act as an SPI slave device that supports a 1.8V or 3.3V SPI master.

Note: SPI voltage depends on VDDO/VDDM; therefore, it defines the type of devices that can be supported.

1.16 Infrared Modulator

The CYW20735 includes hardware support for infrared TX. The hardware can transmit both modulated and unmodulated waveforms. For modulated waveforms, hardware inserts the desired carrier frequency into all IR transmissions. IR TX can be sourced from firmware-supplied descriptors, a programmable bit, or the peripheral UART transmitter.

If descriptors are used, they include IR on/off state and the duration between 1–32767 μ sec. The CYW20735 IR TX firmware driver inserts this information in a hardware FIFO and makes sure that all descriptors are played out without a glitch due to underrun (see Figure 6).

Figure 6. Infrared TX

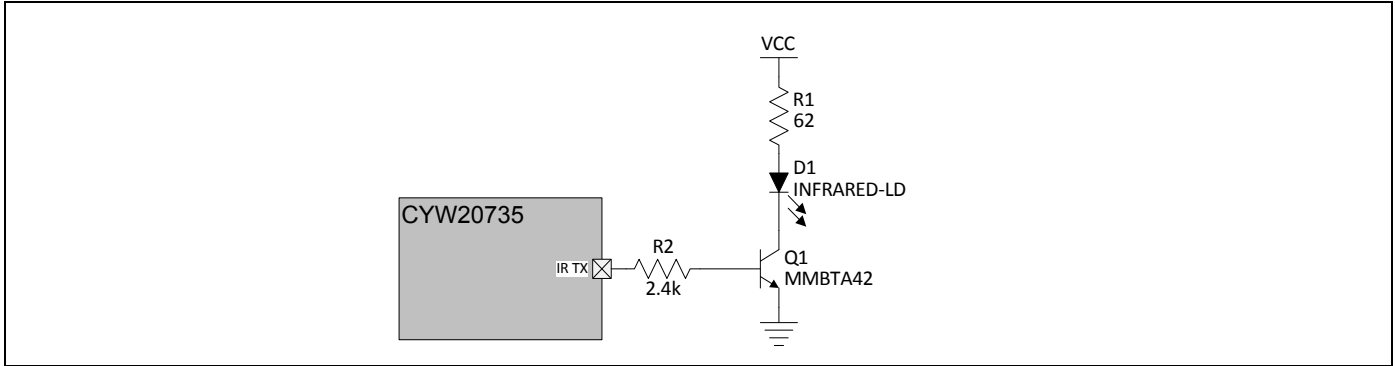

1.17 Infrared Learning

The CYW20735 includes hardware support for infrared learning. The hardware can detect both modulated and unmodulated signals. For modulated signals, the CYW20735 can detect carrier frequencies between 10 kHz and 500 kHz, and the duration that the signal is present or absent. The CYW20735 firmware driver supports further analysis and compression of the learned signal. The learned signal can then be played back through the CYW20735 IR TX subsystem (see Figure 7).

Figure 7. Infrared RX

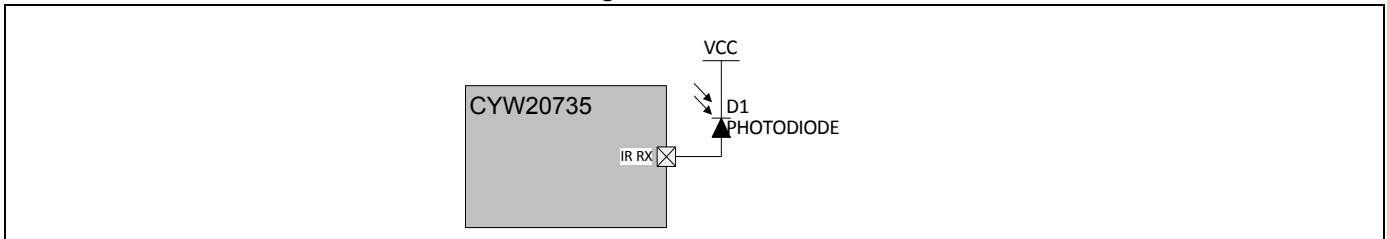

1.18 PDM Microphone

The CYW20735 accepts a $\Sigma\Delta$ -based one-bit pulse density modulation (PDM) input stream and outputs filtered samples at either 8 kHz or 16 kHz sampling rates. The PDM signal derives from an external kit that can process analog microphone signals and generate digital signals. The digital signal passes through the chip IO and MUX inputs using an auxADC signal. The PDM shares the filter path with the auxADC. Two types of data rates can be supported:

- 8 kHz
- 16 kHz

The external digital microphone accepts a 2.4 MHz clock generated by the CYW20735 and outputs a PDM signal which is registered by the PDM interface with either the rising or falling edge of the 2.4 MHz clock selectable through a programmable control bit. The design can accommodate two simultaneous PDM input channels, so stereo voice is possible.

1.19 Security Engine

The CYW20735 includes a hardware security accelerator that greatly decreases the time required to perform typical security operations. These functions include:

- Public key acceleration (PKA) cryptography
- AES-CTR/CBC-MAC/CCM acceleration
- SHA2 message hash and HMAC acceleration
- RSA encryption and decryption of modulus sizes up to 2048 bits
- Elliptic curve Diffie-Hellman in prime field GF(p)
- Generic modular math functions

1.20 Power Management Unit

The Power Management Unit (PMU) provides power management features that can be invoked by software through power management registers or packet-handling in the baseband core.

1.20.1 RF Power Management

The BBC generates power-down control signals for the transmit path, receive path, PLL, and power amplifier to the 2.4 GHz transceiver, which then processes the power-down functions accordingly.

1.20.2 Host Controller Power Management

Power is automatically managed by the firmware based on input device activity. As a power-saving task, the firmware controls the disabling of the on-chip regulator when in HIDEOFF (deep sleep) mode.

1.20.3 BBC Power Management

There are several low-power operations for the BBC:

- Physical layer packet handling turns RF on and off dynamically within packet TX and RX.
- Bluetooth-specified low-power connection mode. While in these low-power connection modes, the CYW20735 runs on the Low Power Oscillator and wakes up after a predefined time period.

The CYW20735 automatically adjusts its power dissipation based on user activity. The following power modes are supported:

- Active mode
- Idle mode
- Sleep mode
- HIDEOFF (deep sleep) mode

The CYW20735 transitions to the next lower state after a programmable period of user inactivity. When user activity resumes, the CYW20735 immediately enters Active mode.

In HIDEOFF mode, the CYW20735 baseband and core are powered off by disabling power to VDDC_OUT and PAVDD. The VDDO domain remains powered up and will turn the remainder of the chip on when it detects user events. This mode minimizes chip power consumption and is used for longer periods of inactivity.

2. Pin Assignments and GPIOs

2.1 Pin Assignments

Table 6. Pin Assignments

Pin Name	QFN Pin	FBGA Pin	I/O	Power Domain	Description
Microphone					
ADC_AVDDBAT	–	A4	I	ADC_AVDD	ADC supply
ADC_AVDDC	–	B8	I	ADC_AVDDC	ADC supply
MIC_AVDD	48	A5	I	MIC_AVDD	Microphone supply
MICBIAS	45	A8	I	MIC_AVDD	Microphone bias supply
MICN	47	A6	I	MIC_AVDD	Microphone negative input
MICP	46	A7	I	MIC_AVDD	Microphone positive input
ADC_AVSS	–	C7	I	AVSS	Analog ground
ADC_AVSSC	–	B7	I	AVSS	Analog ground
ADC_REFGND	–	C8	I	AVSS	Analog reference ground
MIC_AVSS	–	B6	I	AVSS	Microphone analog ground
Baseband Supply					
BT_VDDO	36	D11	I	VDDO	I/O pad power supply
BT_VDDC	37	A10, L4	I	VDDC	Baseband core power supply
BT_VSSC	–	D4, D6, D8, G7	I	VSSC	Digital ground
LHL_VDDO	60	E11	I	VDDO	LHL PAD power supply: can be tied to BT_VDDO
OTP_3P3V	–	G6	I	BT_OTP_3P3V	Power supply to the OTP: Leave floating.
OTP_3P3V_ON	–	F7	I	VDDO	This pin should be connected to ground
RF Power Supply					
BT_PAVDD2P5	26	L8	I	PAVDD2P5	PA supply
BT_PLLVDD1P2	31	J9	I	PLLVDD1P2	RFPLL and crystal oscillator supply
BT_VCOVDD1P2	29	L11	I	VCOVDD1P2	VCO supply
BT_IFVDD1P2	28	J8	I	IFVDD1P2	IFPLL power supply
Onboard LDOs					
DIGLDO_VDDIN1P5	25	K7	I	–	Internal digital LDO input and feedback pin of switching regulator (CBUCK).
DIGLDO_VDDOUT	–	H6	O	–	Internal digital LDO output
RFLDO_VDDIN1P5	24	H7	I	–	RF LDO input
RFLDO_VDDOUT	23	J7	O	–	RF LDO output
PALDO_VDDIN_5V	19	K5	I	–	PA LDO input
PALDO_VDDOUT3V	20	J5	O	–	PA LDO output
SR_VDDBAT3V	22	K6	I	–	Core buck input
VDDBAT3V	–	J6	I	–	Core buck input
SR_VLX	21	L6	O	–	Core buck output
Ground Pins					
SR_PVSS	–	L5	I	VSS	Ground
PMU_AVSS	–	H5	I	PMU_AVSS	PMU ground
HS-VSS	H	–	I	VSS	Digital ground
PALDO_AVSS	–	H4			PALDO ground

Table 6. Pin Assignments (Cont.)

Pin Name	QFN Pin	FBGA Pin	I/O	Power Domain	Description
IF_VSS	–	K8			IFPLL ground
PAVSS	–	K9			PA ground
PLLVSS	–	J10			RFPLL ground
VCOVSS	–	K10			VCO ground
NC_PCB_VSS	–	K11			PCB ground
NC_PCB_VSS1	–	L10			PCB ground
NC_PCB_VSS2	–	L7			PCB ground
UART					
UART_CTS_N	44	F10	I, PU	VDDO	CTS for HCI UART interface. NC if unused.
UART_RTS_N	43	E10	O, PU	VDDO	RTS for HCI UART interface. NC if unused.
UART_RXD	41	F11	I	VDDO	UART serial input. Serial data input for the HCI UART interface.
UART_TXD	42	E9	O, PU	VDDO	UART serial input. Serial data input for the HCI UART interface.
Serial Peripheral Interface					
SPI_MISO	40	A11	I	VDDO	SPI Master In Slave Out
SPI_MOSI	39	B11	O	VDDO	SPI Master Out Slave In
SPI_CSN	38	C10	O	VDDO	SPI Chip Select
SPI_CLK	35	C11	O	VDDO	SPI Clock
Crystal					
BT_XTALI	32	J11	I	PLLVDD1P2	Crystal oscillator input: see “Crystal Oscillator” on page 11 for options
BT_XTALO	33	H11	O	PLLVDD1P2	Crystal oscillator output
XTALI_32K	50	B1	I	VDDO	Low-power oscillator input
XTALO_32K	49	A1	O	VDDO	Low-power oscillator output
Others					
Bond 0	–	E7	N/A	N/A	Reserved: Connect to ground for all applications.
Bond 1		E8			
Bond 2		F6			
Bond 3		E6			
DEFAULT_STRAP	18	K4	I	VDDO	Connect to VDDO
BT_HOST_WAKE	34	H8	O	VDDO	<p>Host wake-up. This is a signal from the Bluetooth device to the host indicating that the Bluetooth device requires attention.</p> <ul style="list-style-type: none"> ■ Asserted: Host device must wake up or remain awake. ■ Deasserted: Host device may sleep when sleep criteria is met. <p>The polarity of this signal is software configurable and can be asserted high or low.</p>

Table 6. Pin Assignments (Cont.)

Pin Name	QFN Pin	FBGA Pin	I/O	Power Domain	Description
BT_DEV_WAKE	–	H9	O	VDDO	Bluetooth device wake-up: This is a signal from the host to the Bluetooth device that the host requires attention. <ul style="list-style-type: none"> ■ Asserted: Bluetooth device must wake up or remain awake. ■ Deasserted: Bluetooth device may sleep when sleep criteria is met. The polarity of this signal is software configurable and can be asserted high or low. By default, BT_DEV_WAKE is active-low (if BT-WAKE is low it requires the device to wake up or remain awake). For USB applications, this pin can be used to disable the BT radio, which puts the device in Airport mode.
BT_RF	27	L9	I/O	PAVDD2P5	RF antenna port
CLK_REQ	–	E5	O	VDDO	Used for shared-clock application.
JTAG_SEL	17	F4	–	–	ARM JTAG debug mode control: connect to GND for all applications
RST_N	16	G4	I	VDDO	Active-low system reset with open-drain output and internal pull-up resistor
BT_TM1	–	G5			Reserved: Connect to GND for all applications.
BT_VDDC_ISO_2	–	G9			Leave floating
VDDC_ISO_1	–	G8			Leave floating
VDDC_ISO_1_2	–	D5			Leave floating
ANATEST	–	E4			Leave floating
NC	30	–			Leave floating

2.2 GPIO Pin Descriptions

Table 7. GPIO Pin Descriptions^{ab}

QFN Pin Number	FBGA Pin Number	Pin Name	Default Direction	POR State	Power Domain	Default Alternate Function
8	F1	P0	Input	Floating	VDDO	<ul style="list-style-type: none"> ■ GPIO: P0 ■ Keyboard scan input (row): KSI0 ■ A/D converter input 29 ■ Peripheral UART: puart_tx ■ SPI_1: MOSI (master and slave) ■ IR_RX ■ 60Hz_main Note: Not available during TM1 = 1.
9	J1	P1	Input	Floating	VDDO	<ul style="list-style-type: none"> ■ GPIO: P1 ■ Keyboard scan input (row): KSI1 ■ A/D converter input 28 ■ Peripheral UART: puart_rts ■ SPI_1: MISO (master and slave) ■ IR_TX
52	A3	P2	Input	Floating	VDDO	<ul style="list-style-type: none"> ■ GPIO: P2 ■ Keyboard scan input (row): KSI2 ■ Quadrature: QDX0 ■ Peripheral UART: puart_rx ■ SPI_1: SPI_CS (slave only) ■ SPI_1: MOSI (master only)
53	A2	P3	Input	Floating	VDDO	<ul style="list-style-type: none"> ■ GPIO: P3 ■ Keyboard scan input (row): KSI3 ■ Quadrature: QDX1 ■ Peripheral UART: puart_cts ■ SPI_1: SPI_CLK (master and slave)



Table 7. GPIO Pin Descriptions^{ab} (Cont.)

QFN Pin Number	FBGA Pin Number	Pin Name	Default Direction	POR State	Power Domain	Default Alternate Function
54	B2	P4	Input	Floating	VDDO	<ul style="list-style-type: none"> ■ GPIO: P4 ■ Keyboard scan input (row): KSI4 ■ Quadrature: QDY0 ■ Peripheral UART: puart_rx ■ SPI_1: MOSI (master and slave) ■ IR_TX
55	C4	P5	Input	Floating	VDDO	<ul style="list-style-type: none"> ■ GPIO: P5 ■ Keyboard scan input (row): KSI5 ■ Quadrature: QDY1 ■ Peripheral UART: puart_tx ■ SPI_1: MISO (master and slave) ■ BSC: SDA
56	C3	P6	Input	Floating	VDDO	<ul style="list-style-type: none"> ■ GPIO: P6 ■ Keyboard scan input (row): KSI6 ■ Quadrature: QDZ0 ■ Peripheral UART: puart_rts ■ SPI_1: SPI_CS (slave only) ■ 60Hz_main
57	C2	P7	Input	Floating	VDDO	<ul style="list-style-type: none"> ■ GPIO: P7 ■ Keyboard scan input (row): KSI7 ■ Quadrature: QDZ1 ■ Peripheral UART: puart_cts ■ SPI_1: SPI_CLK (master and slave) ■ BSC: SCL



Table 7. GPIO Pin Descriptions^{ab} (Cont.)

QFN Pin Number	FBGA Pin Number	Pin Name	Default Direction	POR State	Power Domain	Default Alternate Function
58	C1	P8	Input	Floating	VDDO	<ul style="list-style-type: none"> ■ GPIO: P8 ■ Keyboard scan output (column): KSC0 ■ A/D converter input 27 ■ External T/R switch control: ~tx_pd
1	B4	P9	Input	Floating	VDDO	<ul style="list-style-type: none"> ■ GPIO: P9 ■ Keyboard scan output (column): KSC1 ■ A/D converter input 26 ■ External T/R switch control: tx_pd
2	B3	P10	Input	Floating	VDDO	<ul style="list-style-type: none"> ■ GPIO: P10 ■ Keyboard scan output (column): KSC2 ■ A/D converter input 25 ■ External PA ramp control: ~PA_Ram
3	G11	P11	Input	Floating	VDDO	<ul style="list-style-type: none"> ■ GPIO: P11 ■ Keyboard scan output (column): KSC3 ■ A/D converter input 24
4	L2	P12	Input	Floating	VDDO	<ul style="list-style-type: none"> ■ GPIO: P12 ■ Keyboard scan output (column): KSC4 ■ A/D converter input 23
5	E3	P13	Input	Floating	VDDO	<ul style="list-style-type: none"> ■ GPIO: P13 ■ Keyboard scan output (column): KSC5 ■ A/D converter input 22 ■ PWM3 ■ Triac control 3
59	B10	P14	Input	Floating	VDDO	<ul style="list-style-type: none"> ■ GPIO: P14 ■ Keyboard scan output (column): KSC6 ■ A/D converter input 21 ■ PWM2 ■ Triac control 4



Table 7. GPIO Pin Descriptions^{ab} (Cont.)

QFN Pin Number	FBGA Pin Number	Pin Name	Default Direction	POR State	Power Domain	Default Alternate Function
50	B5	P15	Input	Floating	VDDO	<ul style="list-style-type: none"> ■ GPIO: P15 ■ Keyboard scan output (column): KSO ■ A/D converter input 20 ■ IR_RX ■ 60Hz_main
51	E1	P16	Input	Floating	VDDO	<ul style="list-style-type: none"> ■ GPIO: P16 ■ Keyboard scan output (column): KSO ■ A/D converter input 19
–	E2	P17	Input	Floating	VDDO	<ul style="list-style-type: none"> ■ GPIO: P17 ■ Keyboard scan output (column): KSO ■ A/D converter input 18
–	D3	P18	Input	Floating	VDDO	<ul style="list-style-type: none"> ■ GPIO: P18 ■ Keyboard scan output (column): KSO ■ A/D converter input 17
–	D2	P19	Input	Floating	VDDO	<ul style="list-style-type: none"> ■ GPIO: P19 ■ Keyboard scan output (column): KSO ■ A/D converter input 16
–	D1	P20	Input	Floating	VDDO	<ul style="list-style-type: none"> ■ GPIO: P20 ■ Keyboard scan output (column): KSO
–	J3	P21	Input	Floating	VDDO	<ul style="list-style-type: none"> ■ GPIO: P21 ■ Keyboard scan output (column): KSO ■ A/D converter input 14 ■ Triac control 3



Table 7. GPIO Pin Descriptions^{ab} (Cont.)

QFN Pin Number	FBGA Pin Number	Pin Name	Default Direction	POR State	Power Domain	Default Alternate Function
–	H3	P22	Input	Floating	VDDO	<ul style="list-style-type: none"> ■ GPIO: P22 ■ Keyboard scan output (column): KSO ■ A/D converter input 13 ■ Triac control 4 ■ XTALO32K
–	G3	P23	Input	Floating	VDDO	<ul style="list-style-type: none"> ■ GPIO: P23 ■ Keyboard scan output (column): KSO ■ A/D converter input 12 ■ XTALI32K
–	D10	P24	Input	Floating	VDDO	<ul style="list-style-type: none"> ■ GPIO: P24 ■ Keyboard scan output (column): KSO ■ SPI_1: SPI_CLK (master and slave) ■ Peripheral UART: puart_tx
–	K3	P25	Input	Floating	VDDO	<ul style="list-style-type: none"> ■ GPIO: P25 ■ Keyboard scan output (column): KSO ■ SPI_1: MISO (master and slave) ■ Peripheral UART: puart_rx
13	K1	P26 PWM0	Input	Floating	VDDO	<ul style="list-style-type: none"> ■ GPIO: P26 ■ Keyboard scan output (column): KSO ■ SPI_1: SPI_CS (slave only) ■ Optical control output: QOC0 ■ Triac control 1 ■ Current: 16 mA sink



Table 7. GPIO Pin Descriptions^{ab} (Cont.)

QFN Pin Number	FBGA Pin Number	Pin Name	Default Direction	POR State	Power Domain	Default Alternate Function
14	J2	P27 PWM1	Input	Floating	VDDO	<ul style="list-style-type: none"> ■ GPIO: P27 ■ Keyboard scan output (column): KSO ■ SPI_1: MOSI (master and slave) ■ Optical control output: QOC1 ■ Triac control 2 ■ Current: 16 mA sink
6	F3	P28 PWM2	Input	Floating	VDDO	<ul style="list-style-type: none"> ■ GPIO: P28 ■ Optical control output: QOC2 ■ A/D converter input 11 ■ LED1 ■ Current: 16 mA sink
7	F2	P29 PWM3	Input	Floating	VDDO	<ul style="list-style-type: none"> ■ GPIO: P29 ■ Optical control output: QOC3 ■ A/D converter input 10 ■ LED2 ■ Current: 16 mA sink
–	L1	P30 PWM4	Input	Floating	VDDO	<ul style="list-style-type: none"> ■ GPIO: P30 ■ A/D converter input 9 ■ Peripheral UART: puart_rts
–	L3	P31 PWM5	Input	Floating	VDDO	<ul style="list-style-type: none"> ■ GPIO: P31 ■ A/D converter input 8 ■ Peripheral UART: puart_tx



Table 7. GPIO Pin Descriptions^{ab} (Cont.)

QFN Pin Number	FBGA Pin Number	Pin Name	Default Direction	POR State	Power Domain	Default Alternate Function
15	A9	P32	Input	Floating	VDDO	<ul style="list-style-type: none"> ■ GPIO: P32 ■ A/D converter input 7 ■ Quadrature: QDX0 ■ SPI_1: SPI_CS (slave only) ■ Auxiliary clock output: ACLK0 ■ Peripheral UART: puart_tx
–	H10	P33	Input	Floating	VDDO	<ul style="list-style-type: none"> ■ GPIO: P33 ■ A/D converter input 6 ■ Quadrature: QDX1 ■ SPI_1: MOSI (slave only) ■ Auxiliary clock output: ACLK1 ■ Peripheral UART: puart_rx
10	G2	P34	Input	Floating	VDDO	<ul style="list-style-type: none"> ■ GPIO: P34 ■ A/D converter input 5 ■ Quadrature: QDY0 ■ Peripheral UART: puart_rx ■ External T/R switch control: tx_pd
–	H2	P35	Input	Floating	VDDO	<ul style="list-style-type: none"> ■ GPIO: P35 ■ A/D converter input 4 ■ Quadrature: QDY1 ■ Peripheral UART: puart_cts ■ BSC: SDA



Table 7. GPIO Pin Descriptions^{ab} (Cont.)

QFN Pin Number	FBGA Pin Number	Pin Name	Default Direction	POR State	Power Domain	Default Alternate Functions
–	G1	P36	Input	Floating	VDDO	<ul style="list-style-type: none"> ■ GPIO: P36 ■ A/D converter input 3 ■ Quadrature: QDZ0 ■ SPI_1: SPI_CLK (master and slave) ■ Auxiliary Clock Output: ACLK0 ■ External T/R switch control: ~tx_pd
–	H1	P37	Input	Floating	VDDO	<ul style="list-style-type: none"> ■ GPIO: P37 ■ A/D converter input 2 ■ Quadrature: QDZ1 ■ Infrared control: IR_RX ■ SPI_1: MISO (slave only) ■ Auxiliary clock output: ACLK1 ■ BSC: SCL
11	G10	P38	Input	Floating	VDDO	<ul style="list-style-type: none"> ■ GPIO: P38 ■ A/D converter input 1 ■ SPI_1: MOSI (master and slave) ■ IR_TX
12	K2	P39	Input	Floating	VDDO	<ul style="list-style-type: none"> ■ GPIO: P39 ■ SPI_1: SPI_CS (slave only) ■ External PA ramp control: PA_Ramp ■ 60Hz_main

a. All GPIOs are supermux. All GPIOs can be programmed for any alternative functions. For example, key scan, SPI, I²C, IR_TX, quadrature, peripheral UART

b. During power-on reset, all inputs are disabled.

Table 8. GPIO Supermux Input/Output Function List

Function	Function	Function	Function
SPI_1: CLK	SPI_1: CS	SPI_1: MOSI	SPI_1: MISO
SPI_1: INT	SPI_2: CLK	SPI_2: CS	SPI_2: MOSI
SPI_2: MISO	SPI_2: INT	SPI_3: CLK	SPI_3: CS
SPI_3: MOSI	SPI_3: MISO	SPI_3: INT	UART_RX
UART_CTS	UART_TX	UART_RTS	PUART_RX
PUART_CTS	PUART_TX	PUART_RTS	SCL
SDA	SCL2	SDA2	PCM_IN
PCM_OUT	PCM_CLK	PCM_SYNC	I2S_DO
I2S_DI	I2S_WS	I2S_CLK	IR_TX
kso0	kso1	kso2	kso3
kso4	kso5	kso6	kso7
kso8	kso9	kso10	kso11
kso12	kso13	kso14	kso15
kso16	kso17	kso18	kso19
PWM0	PWM1	PWM2	PWM3
PWM4	PWM5	aclk0	aclk1
pa_ramp	tx_pd	~tx_pd	–

2.3 Ball Maps

2.3.1 60-Pin QFN Package

The 60-pin QFN package is shown in Figure 8.

Figure 8. CYW20735 60-Pin QFN Package

		60	59	58	57	56	55	54	53	52	51	50	49	48	47	46		
		LHL_VDDO	P14	P8	P7	P6	P5	P4	P3	P2	P16	P15/XTAL1_32K	XTALO_32K	MIC_AVDD	MICN	MICP		
1	P9	<div style="border: 1px solid black; width: 100%; height: 100%; display: flex; align-items: center; justify-content: center;"> <div style="text-align: center;"> <p>H</p> <p>HS-VSS</p> </div> </div>														45	MICBIAS	
2	P10															44	UART_CTS_N	
3	P11															43	UART_RTS_N	
4	P12															42	UART_TXD	
5	P13															41	UART_RXD	
6	P28															40	SPI_MISO	
7	P29															39	SPI_MOSI	
8	P0															38	SPI_CSN	
9	P1															37	BT_VDDC	
10	P34															36	BT_VDDO	
11	P38															35	SPI_CLK	
12	P39															34	BT_HOST_WAKE	
13	P26															33	BT_XTALO	
14	P27															32	BT_XTALI	
15	P32															31	BT_PLLVDD1P2	
		RST_N	JTAG_SEL	DEFAULT_STRAP	PALDO_VDDIN_5V	PALDO_VDDOUT3V	SR_VLX	SR_VDDBAT3V	RFLDO_VDDOUT	RFLDO_VDDIN1P5	DIGLDO_VDDIN1P5	BT_PAVDD2P5	BT_RF	BT_IFVDD1P2	BT_VCOVDD1P2	---		
16	17	18	19	20	21	22	23	24	25	26	27	28	29	30				

Note: Pin H is a ground pin that is used for the signal name HS-VSS.

2.3.2 111-Pin FBGA Package

The 111-pin FBGA package is shown in Figure 9.

Figure 9. CYW20735 111-Pin FBGA Package

	1	2	3	4	5	6	7	8	9	10	11
A	A1 XTALO_32K	A2 P3	A3 P2	A4 ADC_ AVDDB	A5 MIC_AVDD	A6 MICN	A7 MICP	A8 MICBIAS	A9 P32	A10 BT_VDD C	A11 SPI_MISO
B	B1 XTALI_32K	B2 P4	B3 P10	B4 P9	B5 P15	B6 MIC_AVSS	B7 ADC_ AVSSC	B8 ADC_ AVDDC		B10 P14	B11 SPI_MOSI
C	C1 P8	C2 P7	C3 P6	C4 P5			C7 ADC_AVSS	C8 ADC_ REFGND		C10 SPI_CSN	C11 SPI_CLK
D	D1 P20	D2 P19	D3 P18	D4 BT_VSS C	D5 VDDC_ISO_ 1_2	D6 BT_VSSC		D8 BT_VSSC		D10 P24	D11 BT_VDDO
E	E1 P16	E2 P17	E3 P13	E4 ANATES T	E5 CLK_REQ	E6 BOND_3	E7 BOND_0	E8 BOND_1	E9 UART_TXD	E10 UART_ RTS_N	E11 LHL_VDD O
F	F1 P0	F2 P29	F3 P28	F4 JTAG_S EL		F6 BOND_2	F7 OTP_3P3V ON			F10 UART_ CTS_N	F11 UART_RX D
G	G1 P36	G2 P34	G3 P23	G4 RST_N	G5 BT_TM1	G6 OTP_3P3V	G7 BT_VSSC	G8 VDDC_ ISO 1	G9 BT_VDDC_ ISO 2	G10 P38	G11 P11
H	H1 P37	H2 P35	H3 P22	H4 PALDO_ AVSS	H5 PMU_AVSS	H6 DIGLDO_ VDDOUT	H7 RFLDO_ VDDIN1P5	H8 BT_HOST	H9 BT_DEV_ WAKE	H10 P33	H11 BT_XTALO
J	J1 P1	J2 P27	J3 P21		J5 PALDO_ VDDOUT3V	J6 VDDBAT3V	J7 RFLDO_ VDDOUT	J8 BT_ IFVDD1P2	J9 BT_ PLLVD1P	J10 PLL_VSS	J11 BT_XTALI
K	K1 P26	K2 P39	K3 P25	K4 DEFAULT_ T	K5 PALDO_ VDDIN_5V	K6 SR_ VDDBAT3V	K7 DIGLDO_ VDDIN1P5	K8 IF_VSS	K9 PAVSS	K10 VCOVSS	K11 NC_PCB_ VSS
L	L1 P30	L2 P12	L3 P31	L4 BT_VDD C	L5 SR_PVSS	L6 SR_VLX	L7 NC_PCB_ VSS2	L8 BT_ PAVDD2P	L9 BT_RF	L10 NC_PCB_ VSS1	L11 BT_ VCOVDD1

3. Specifications

3.1 Electrical Characteristics

Caution! The absolute maximum ratings in the following table indicate levels where permanent damage to the device can occur, even if these limits are exceeded for only a brief duration. Functional operation is not guaranteed under these conditions. Operation at absolute maximum conditions for extended periods can adversely affect long-term reliability of the device

Table 9. Absolute Maximum Ratings

Requirement Parameter	Specification			Unit
	Min.	Nom.	Max.	
Maximum Junction Temperature	–	–	125	°C
VDD IO	–0.5	–	3.795	V
VDD RF	–0.5	–	1.38	V
VDDBAT3V	–0.5	–	3.795	V
DIGLDO_VDDIN1P5	–0.5	–	1.65	V
RFLDO_VDDIN1P5	–0.5	–	1.65	V
PALDO_VDDIN_5V	–0.5	–	3.795	V
MIC_AVDD	–0.5	–	3.795	V
OTP_3P3V	–0.5	–	3.795	V

Table 10. ESD/Latchup

Requirement Parameter	Specification			Unit
	Min.	Nom.	Max.	
ESD Tolerance HBM	–2000	–	2000	V
ESD Tolerance CDM	–500	–	500	V
Latch-up	–	200	–	mA

Table 11. Environmental Ratings

Characteristic	Value	Units
Operating Temperature	–30 to +85	°C
Storage Temperature	–40 to +150	°C

Table 12. Recommended Operating Conditions

Parameter	Specification			Unit
	Min.	Typ.	Max.	
VDD IO ^a	V _{SHUT} ^b	3.0	3.63	V
VDDRF	1.14	1.2	1.26	V
VDDBAT3V ^a	V _{SHUT} ^b	3.0	3.63	V
PALDO_VDDIN_5V	2.5	3.3	3.63	
DIGLDO_VDDIN1P5	1.3	1.35	1.5	V
RFLDO_VDDIN1P5	1.3	1.35	1.5	V
MIC_AVDD	V _{SHUT} ^b	3.0	3.63	V

Table 12. Recommended Operating Conditions

Parameter	Specification			Unit
	Min.	Typ.	Max.	
OTP_3P3V	3.0	3.3	3.63	V

- a. VDDIO must be greater or equal to V_{BAT} .
- b. See [Table 13](#).

The CYW20735 uses an onboard low voltage detector to shut down the part when supply voltage (VDDBAT3V) drops below operating range.

Table 13. Shutdown Voltage

Parameter	Specification			Unit
	Min.	Typ.	Max.	
V _{SHUT}	1.625	1.7	1.775	V

3.1.1 Core Buck Regulator
Table 14. Core Buck Regulator

Parameter	Conditions	Min.	Typ.	Max.	Unit
Input supply voltage DC, VBAT	DC voltage range	1.62	3.0	3.63	V
CBUCK output current	–	–	–	65	mA
Output voltage range	Programmable, 30mV/step default = 1.35V (bits = 0000)	1.2	1.35	1.5	V
Output voltage DC accuracy	Includes load and line regulation	–4	–	+4	%
LPOM ripple voltage, static	Measured with 20 MHz bandwidth limit, static load. Max ripple based on VBAT = 3V, Vout = 1.35V Inductor: 0806 inch-size, Tmax = 1 mm, 2.2 μ H \pm 25%, DCR = 114 m Ω \pm 20%, ACR<1 Ω (for frequency <1 MHz) Capacitor: 1 μ F \pm 10%, 6.3V, 0603 inch, X5R, MLCC capacitor + board total-ESR < 20 m Ω	–	–	30	mVpp
Efficiency (high load)	10–50 mA load current, Vout = 1.35V, Vbat = 3V @25°C Inductor: 0806 inch-size, Tmax = 1 mm, 2.2 μ H \pm 25%, DCR = 114 m Ω \pm 20%, ACR<1 Ω (for frequency<1 MHz) Capacitor: 1 μ F \pm 10%, 6.3V, 0603 inch, X5R, MLCC capacitor +board total-ESR < 20 m Ω	–	85	–	%
Efficiency (low load)	1–5 mA load current, Vout = 1.35V, Vbat = 3V @25°C Inductor: 0806 inch-size, Tmax = 1 mm, 2.2 μ H \pm 25%, DCR = 114 m Ω \pm 20%, ACR<1 Ω (for frequency<1 MHz) Capacitor: 1 μ F \pm 10%, 6.3V, 0603 inch, X5R, MLCC capacitor +board total-ESR < 20 m Ω	–	80	–	%
Startup time	See Table 15 on page 35 .	–	–	–	–
External inductor L	2.2 μ H \pm 25%, DCR = 114 m Ω \pm 20%, ACR<1 Ω (for frequency<1 MHz)	–	2.2	–	μ H
External output capacitor, Cout	1 μ F \pm 10%, 6.3V, 0603 inch, X5R, MLCC capacitor +board total-ESR < 20 m Ω	0.7	1	1.1	μ F
External input capacitor, Cin	For SR_VDDBAT 3V pin Ceramic, X5R, 0402, ESR<30 m Ω at 4 MHz, +/-20%, 6.3V, 4.7 μ F	0.7	4.7	5.64	μ F
Input supply voltage ramp-up time	0 to 3.3V	40	–	–	μ s

- Minimum capacitor value refers to residual capacitor value after taking into account part-to-part tolerance, DC-bias, temperature, and aging.
- Maximum capacitor value refers to the total capacitance seen at a node where the capacitor is connected. This also includes any decoupling capacitors connected at the load side, if any.

3.1.2 Digital LDO
Table 15. Digital LDO

Parameter	Conditions	Min.	Typ.	Max.	Unit
Input supply voltage, V_{in}	Minimum $V_{in} = V_o + 0.12V$ requirement must be met under maximum load.	1.3	1.35	1.5	V
Nominal output voltage, V_o	Internal default bit setting	–	1.2	–	V
Output voltage programmability	Range Step size Accuracy at any step (including line/load regulation)	0.9 – –4	– 10 –	1.25 – +4	V mV %
Dropout voltage	At maximum load	–	–	120	mV
Output current	DC load	0.2 ^a	–	40	mA
Output loading capacitor	Internal, including the decoupling capacitor to be placed next to the load and the equivalent loading capacitor by the core.	4	–	10	nF
Quiescent current	At no load, excluding main bandgap I_q	–	90	120	μA
Line regulation	V_{in} from ($V_o+0.12V$) to 1.5V; 40 mA load	–	–	5	mV/V
Load regulation	Load from 1 mA to 25 mA; V_{in} ($V_o+0.12V$)	–	0.025	0.045	mV/mA
Leakage current	In full power-down mode or bypass mode: Junction temperature: 25°C Junction temperature: 125°C	– –	0.05 1.1	0.2 5.0	μA μA
PSRR	@1 kHz, V_{in} , $V_o+0.12V$ Output cap of 4 nF~10 nF	40	–	–	dB
LDO turn-on time	LDO turn-on time when balance of chip is up	–	–	22	μs
External input capacitor	Only use an external input capacitor at VDD_DIGL-DO1P5 pin if it is not supplied from CBUCK output.	–	1	2.2	μF

a. By default, an internal loading of ~0.2 mA resides inside the LDO. This is to ensure the LDO is stable with zero loading from the core. After the core is up, digital logic can disable this internal loading by setting `i_ido_cntl<8:7>` to 00.

3.1.3 PA LDO

Table 16. PA LDO

Specification	Notes	Min.	Typ.	Max.	Units
Input supply voltage	Min = 3.0 + 0.1V = 3.1V Dropout voltage requirement must be met under max load for performance specs	2.5	3.3	3.63	V
Output current	Junction temperature 125°C	–	–	50	mA
Output voltage (Vo)	Default = 3.0V	2.4	3.0	3.4	V
Dropout voltage	At max. load	–	–	100	mV
Output voltage DC accuracy	Include line/load regulation	–5		+5	%
Quiescent current	No load	–	8	–	µA
Line regulation	Vin from (Vo + 0.1V) to 4.8V, max load	–0.2		+0.2	%Vo/V
Load regulation	Load from 1 mA to 50 mA		0.02	0.05	%Vo/mA
Leakage current	In Power-Down mode at 25°C junction temp	–	0.3	–	µA
PSRR	Vbat 3.6V, Vo = 2.5V, Co = 1 µF, max load, 100 Hz to 100 kHz	20	–		dB
LDO turn-on time	LDO turn-on time when the rest of the chip is up	–	–	100	µs
In-rush current during turn-on	From its output cap in the fully-discharged state	–	–	70	mA
External output capacitor (Co)	Ceramic, X5R, 0402, (ESR: 30m–200 mΩ), ±10%, 6.3V	0.44	1	–	µF
External input capacitor	For PALDO_VDDIN_5V pin Ceramic, X5R, 0402, (ESR: 30m-200 mΩ), ±10%, 6.3V	–	1	–	µF

3.1.4 RFLDO

Table 17. RFLDO

Parameter	Conditions	Min.	Typ.	Max.	Unit
Input supply voltage, V_{in}	Min $V_{in} = V_o + 0.15V = 1.35V$ (for $V_o = 1.2V$) Dropout voltage requirement must be met under maximum load.	1.3	1.35	1.5	V
Nominal output voltage, V_o	Internal default bit setting 000	–	1.2	–	V
Output voltage programmability	Range	1.1	–	1.275	V
	Step size	–	25	–	mV
	Accuracy at any step (including line/load regulation)	–4	–	+4	%
Dropout voltage	At maximum load	–	–	150	mV
Output current	Operating voltage range	0.1	–	25	mA
Quiescent current	No load	–	44	–	μA
Line regulation	V_{in} from ($V_o+0.15V$) to 1.5V; 25 mA load	–	–	5.5	mV/V
Load regulation	Load from 1 mA to 25 mA; $V_{in} \geq (V_o+0.15V)$	–	0.025	0.045	mV/mA
Load step error	Load step from 1 mA–25 mA in 1 μs and 25 mA–1 mA in 1 μs ; $V_{in}(V_o+0.15V)$; $C_o = 2.2 \mu F$	–	–	35	mV
Leakage current	Power-down junction temperature: 85°C	–	–	10	μA
Output noise	@30 kHz, 25 mA load, $C_o = 2.2 \mu F$	–	–	60	nV/ \sqrt{Hz}
	@100 kHz, 25 mA load, $C_o = 2.2 \mu F$	–	–	35	nV/ \sqrt{Hz}
PSRR	@1kHz, Input > 1.35V, $C_o = 2.2 \mu F$, $V_o = 1.2V$	20	–	–	dB
LDO turn-on time	LDO turn-on time when balance of chip is up	–	140	180	μs
In-rush current	$V_{in} = V_o+0.15V$ to 1.5V, $C_o = 2.2 \mu F$, no load	–	–	100	mA
External output capacitor, C_o	Total ESR (trace/cap): 5 m–240 m Ω	0.5	2.2	4.7	μF
External input capacitor	Only use an external input capacitor at RFLDO_VD-DIN1P5 pin if it is not supplied from CBUCK output.	–	1	2.2	μF

Note: Minimum capacitor value refers to residual capacitor value after taking into account part-to-part tolerance, DC-bias, temperature, and aging.

3.1.5 Digital I/O Characteristics

Table 18. Digital I/O Characteristics

Characteristics	Symbol	Minimum	Typical	Maximum	Unit
Input low voltage (VDDO = 3.3V)	V_{IL}	–	–	0.8	V
Input high voltage (VDDO = 3.3V)	V_{IH}	2.0	–	–	V
Input low voltage (VDDO = 1.8V)	V_{IL}	–	–	0.6	V
Input high voltage (VDDO = 1.8V)	V_{IH}	1.1	–	–	V
Output low voltage	V_{OL}	–	–	0.4	V
Output high voltage	V_{OH}	VDDO – 0.4V	–	–	V
Input low current	I_{IL}	–	–	1.0	μ A
Input high current	I_{IH}	–	–	1.0	μ A
Output low current (VDDO = 3.3V, V_{OL} = 0.4V)	I_{OL}	–	–	2.0	mA
Output high current (VDDO = 3.3V, V_{OH} = 2.9V)	I_{OH}	–	–	4.0	mA
Output high current (VDDO = 1.8V, V_{OH} = 1.4V)	I_{OH}	–	–	2.0	mA
Input capacitance	C_{IN}	–	–	0.4	pF

3.1.6 Current Consumption

In [Table 19](#), current consumption measurements are taken at VBAT with the assumption that VBAT is connected to VDDIO and LDOIN.

Table 19. BLE Current Consumption

Operational Mode	Conditions	Typical	Unit
Receiving	Receiver and baseband are both operating, 100% ON.	8	mA
Transmitting	Transmitter and baseband are both operating, 100% ON.	18	mA
Advertising	1.28s direct advertising in low power idle mode	30	μ A
Scanning	TBD	TBD	mA
Connecting	1-second connection interval in low power idle mode	25	μ A
HIDOFF (Deep Sleep)	–	1	μ A

3.2 ADC Microphone Specifications

Table 20. ADC Microphone Specifications

Parameter	Symbol	Conditions/Comments	Min.	Typ.	Max.	Unit
Analog supply voltage	avddBAT	Battery and I/O supply	1.62	–	3.6	V
Analog core supply	AVDDC	±10%	1.08	1.2	1.32	V
Audio supply	Mic_avdd	Only available for audio application	1.8	2.5	3.3	V
Current consumption	I _{TOT}	–	–	2	3	mA
Power down current	–	At room temperature	–	1	–	µA
ADC Core Specification						
ADC reference voltage	VREF	From BG with ±3% accuracy	–	0.85	–	V
ADC sampling clock	–	–	–	12	–	MHz
Absolute error	–	Includes gain error, offset and distortion. Without factory calibration.	–	–	5	%
		Includes gain error, offset and distortion. After factory calibration.	–	–	2	%
ENOB	–	For audio application	12	13	–	Bit
		For static measurement	10	–	–	
ADC input full scale	FS	For audio application	–	1.6	–	
		For static measurement	1.8	–	3.6	
Conversion rate	–	For audio application	8	16	–	kHz
		For static measurement	50	100	–	
Signal bandwidth	–	For audio application	20	–	8K	Hz
		For static measurement	–	DC	–	
Input impedance	R _{IN}	For audio application	10	–	–	KΩ
		For static measurement	500	–	–	
Startup time	–	For audio application	–	10	–	ms
		For static measurement	–	20	–	
MIC PGA Specifications						
MIC PGA gain range	–	–	0	–	42	dB
MIC PGA gain step	–	–	–	1	–	dB
MIC PGA gain error	–	Includes part-to-part gain variation	–1	–	1	dB
PGA input referred noise	–	At 42 dB PGA gain A-weighted	–	–	4	µV
Passband gain flatness	–	PGA and ADC, 100 Hz–4 kHz	–0.5	–	0.5	dB
MIC Bias Specifications						
MIC bias output voltage	–	At 2.5V supply	–	2.1	–	V
MIC bias loading current	–	–	–	–	3	mA
MIC bias noise	–	Refers to PGA input 20 Hz to 8 kHz, A-weighted	–	–	3	µV
MIC bias PSRR	–	at 1 kHz	40	–	–	dB
ADC SNR	–	A-weighted 0 dB PGA gain	78	–	–	dB
ADC THD + N	–	–3 dBFS input 0 dB PGA gain	74	–	–	dB
GPIO input voltage	–	Always lower than avddBAT	–	–	3.6	V
GPIO source impedance ^a	–	Resistance	–	–	1	kΩ
		Capacitance	–	–	10	pF

a. Conditional requirement for the measurement time of 10 µs. Relaxed with longer measurement time for each GPIO input channel.

3.3 RF Specifications

Note: Table 21 and Table 22 on page 42 apply to single-ended industrial temperatures. Unused inputs are left open.

Table 21. Receiver RF Specifications

Parameter	Conditions	Minimum	Typical ^a	Maximum	Unit
General					
Frequency range	–	2402	–	2480	MHz
RX sensitivity ^b	–	–	–91.5	–	–
Maximum input	GFSK, 1 Mbps	–	–	–20	dBm
Interference Performance					
TBD					
Out-of-Band Blocking Performance (CW)^c					
30 MHz–2000 MHz	0.1% BER	–	–10.0	–	dBm
2000–2399 MHz	0.1% BER	–	–27	–	dBm
2498–3000 MHz	0.1% BER	–	–27	–	dBm
3000 MHz–12.75 GHz	0.1% BER	–	–10.0	–	dBm
Intermodulation Performance^d					
BT, Df = 4 MHz	–	–39.0	–	–	dBm
Spurious Emissions^e					
30 MHz to 1 GHz	–	–	–	–62	dBm
1 GHz to 12.75 GHz	–	–	–	–47	dBm
65 MHz to 108 MHz	FM RX	–	–147	–	dBm/Hz
746 MHz to 764 MHz	CDMA	–	–147	–	dBm/Hz
851–894 MHz	CDMA	–	–147	–	dBm/Hz
925–960 MHz	EDGE/GSM	–	–147	–	dBm/Hz
1805–1880 MHz	EDGE/GSM	–	–147	–	dBm/Hz
1930–1990 MHz	PCS	–	–147	–	dBm/Hz
2110–2170 MHz	WCDMA	–	–147	–	dBm/Hz

a. Typical operating conditions are 1.22V operating voltage and 25°C ambient temperature.

b. The receiver sensitivity is measured at BER of 0.1% on the device interface.

c. Meets this specification using front-end band pass filter.

d. $f_0 = -64$ dBm Bluetooth-modulated signal, $f_1 = -39$ dBm Bluetooth-modulated signal, $f_0 = 2f_1 - f_2$, and $|f_2 - f_1| = n \cdot 1$ MHz, where n is 3, 4, or 5. For the typical case, n = 4.

e. Includes baseband radiated emissions.

Table 22. Transmitter RF Specifications (TBD)

Parameter	Conditions	Minimum	Typical	Maximum	Unit
General					
Frequency range	–	2402	–	2480	MHz
Class 1: GFSK TX power	–	–	10	–	dBm
Power control step	–	2	4	8	dB
Out-of-Band Spurious Emissions					
30 MHz to 1 GHz	–	–	–	–36.0 ^a	dBm
1 GHz to 12.75 GHz	–	–	–	–30.0 ^{a, b}	dBm
1.8 GHz to 1.9 GHz	–	–	–	–47.0	dBm
5.15 GHz to 5.3 GHz	–	–	–	–47.0	dBm

a. Maximum value is the value required for Bluetooth qualification.

b. Meets this spec using a front-end band-pass filter.

Table 23. BLE RF Specifications

Parameter	Conditions	Minimum	Typical	Maximum	Unit
Frequency range	N/A	2402	–	2480	MHz
RX sense ^a	GFSK, 0.1% BER, 1 Mbps	–	–94.5	–	dBm
TX power ^b	N/A	–	9	–	dBm
Mod Char: Delta F1 average	N/A	225	255	275	kHz
Mod Char: Delta F2 max ^c	N/A	99.9	–	–	%
Mod Char: Ratio	N/A	0.8	0.95	–	%

a. Dirty TX is Off.

b. The BLE TX power can be increased to compensate for front-end losses such as BPF, diplexer, switch, etc. The output is capped at 12 dBm out. The BLE TX power at the antenna port cannot exceed the 10 dBm EIRP specification limit.

c. At least 99.9% of all delta F2 max frequency values recorded over 10 packets must be greater than 185 kHz.

3.4 Timing and AC Characteristics

In this section, use the numbers listed in the Reference column of each table to interpret the following timing diagrams.

3.4.1 UART Timing

Table 24. UART Timing Specifications

Reference	Characteristics	Min.	Max.	Unit
1	Delay time, UART_CTS_N low to UART_TXD valid	–	1.50	Baud periods
2	Setup time, UART_CTS_N high before midpoint of stop bit	–	0.67	Baud periods
3	Delay time, midpoint of stop bit to UART_RTS_N high	–	1.33	Baud periods

Figure 10. UART Timing

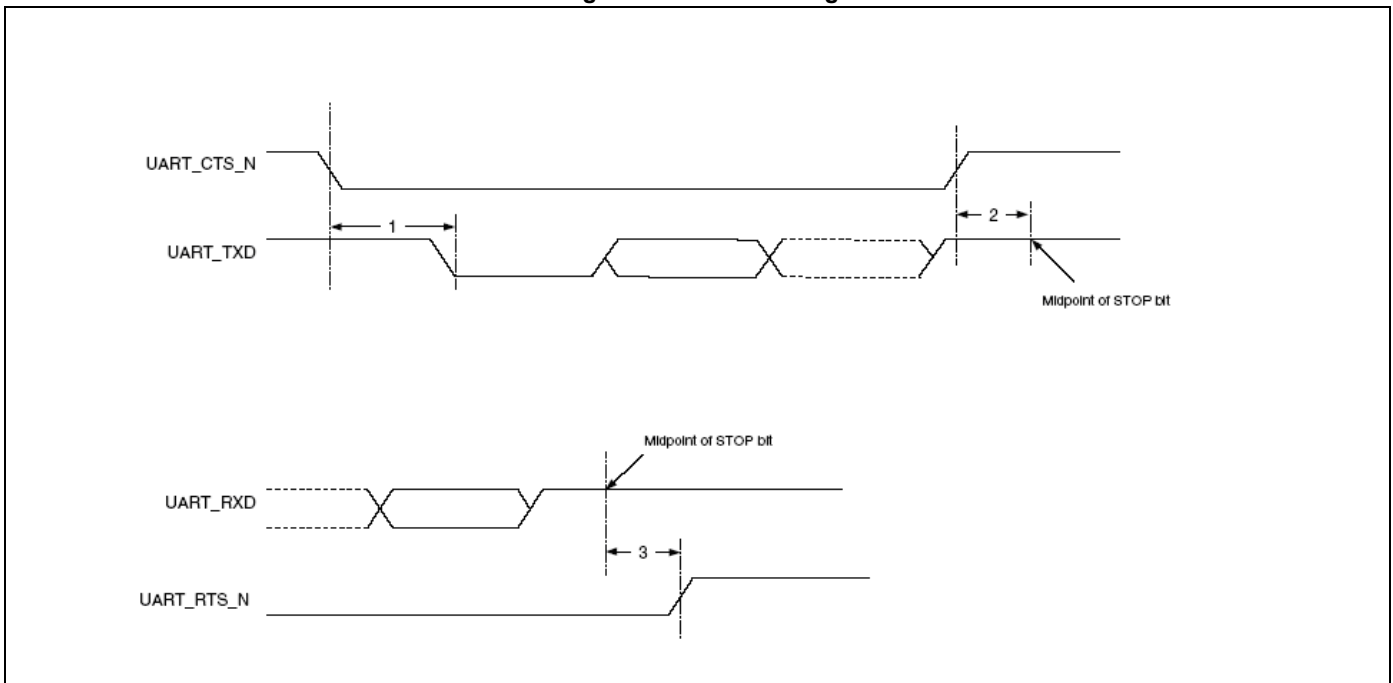

3.4.2 SPI Timing

The SPI interface can be clocked up to 12 MHz.

Table 25 and Figure 11 show the timing requirements when operating in SPI Mode 0 and 2.

Table 25. SPI Mode 0 and 2

Reference	Characteristics	Min.	Max.	Unit
1	Time from master assert SPI_CSN to first clock edge	45	–	ns
2	Hold time for MOSI data lines	12	1/2 SCK	ns
3	Time from last sample on MOSI/MISO to slave deassert SPI_INT	0	100	ns
4	Time from slave deassert SPI_INT to master deassert SPI_CSN	0	–	ns
5	Idle time between subsequent SPI transactions	1 SCK	–	ns

Figure 11. SPI Timing, Mode 0 and 2

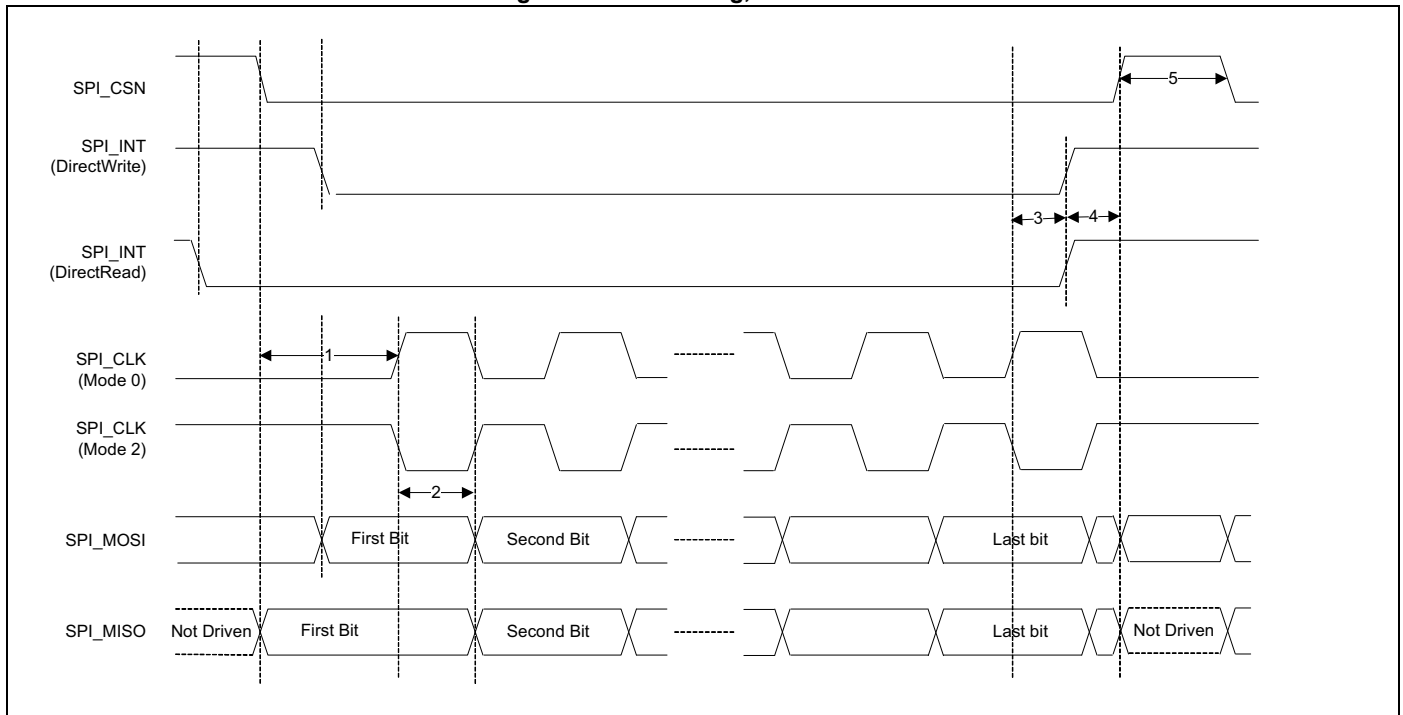
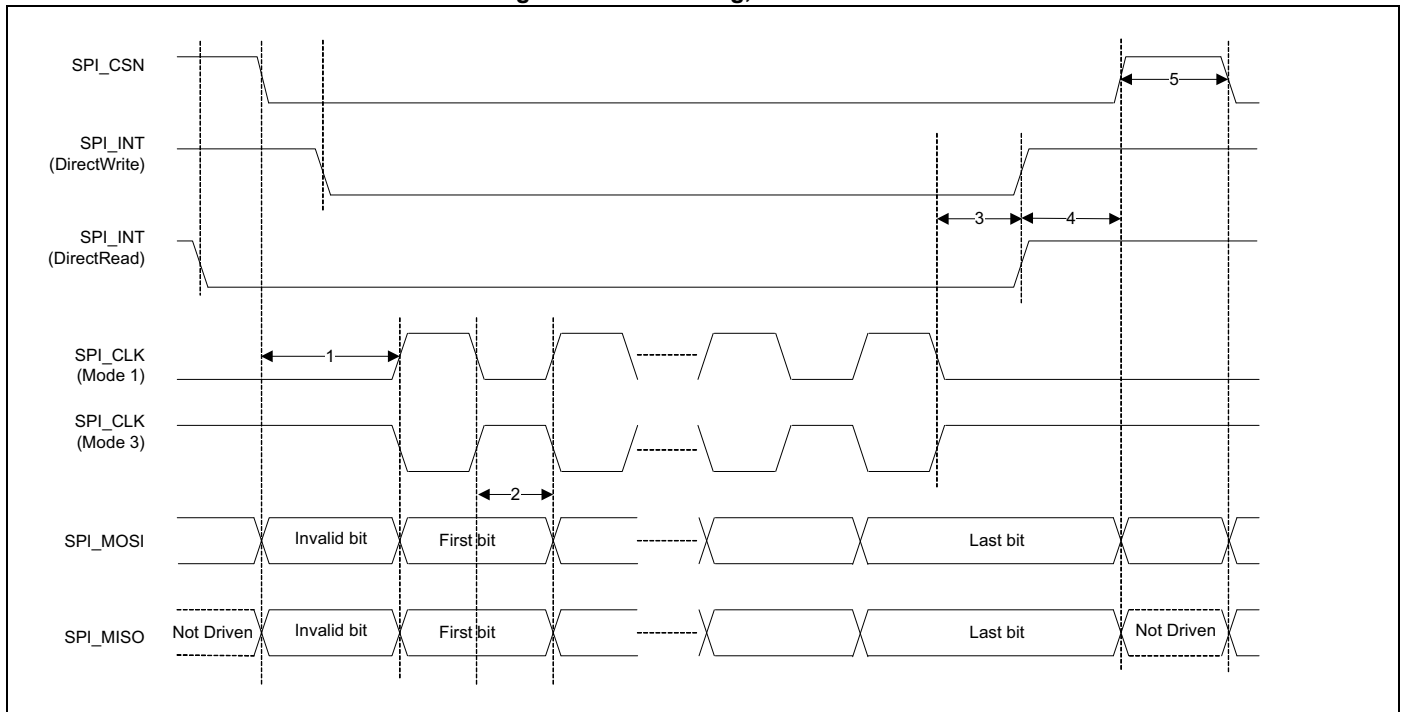

Table 26 and Figure 12 show the timing requirements when operating in SPI Mode 1 and 3.

Table 26. SPI Mode 1 and 3

Reference	Characteristics	Min.	Max.	Unit
1	Time from master assert SPI_CSN to first clock edge	45	–	ns
2	Hold time for MOSI data lines	12	1/2 SCK	ns
3	Time from last sample on MOSI/MISO to slave deassert SPI_INT	0	100	ns
4	Time from slave deassert SPI_INT to master deassert SPI_CSN	0	–	ns
5	Idle time between subsequent SPI transactions	1 SCK	–	ns

Figure 12. SPI Timing, Mode 1 and 3



3.4.3 BSC Interface Timing

The specifications in Table 27 references Figure 13.

Table 27. BSC Interface Timing Specifications (up to 1 MHz)

Reference	Characteristics	Minimum	Maximum	Unit
1	Clock frequency	-	100	kHz
			400	
			800	
			1000	
2	START condition setup time	650	-	ns
3	START condition hold time	280	-	ns
4	Clock low time	650	-	ns
5	Clock high time	280	-	ns
6	Data input hold time ^a	0	-	ns
7	Data input setup time	100	-	ns
8	STOP condition setup time	280	-	ns
9	Output valid from clock	-	400	ns
10	Bus free time ^b	650	-	ns

a. As a transmitter, 125 ns of delay is provided to bridge the undefined region of the falling edge of SCL to avoid unintended generation of START or STOP conditions.

b. Time that the CBUS must be free before a new transaction can start.

Figure 13. BSC Interface Timing Diagram

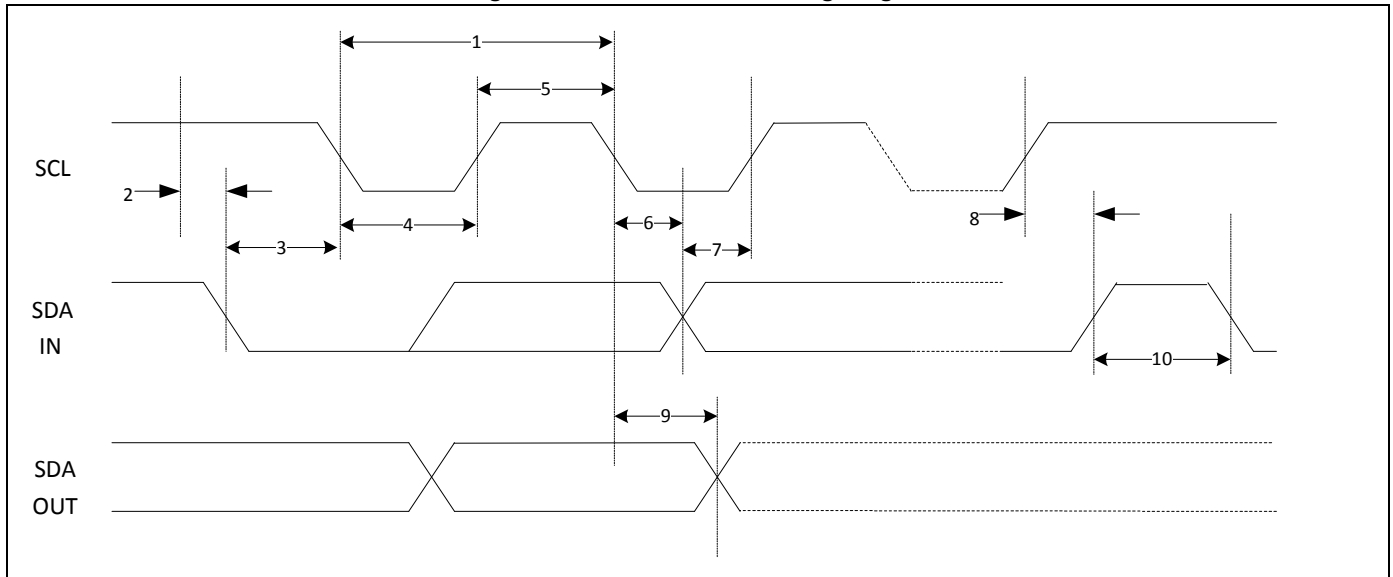
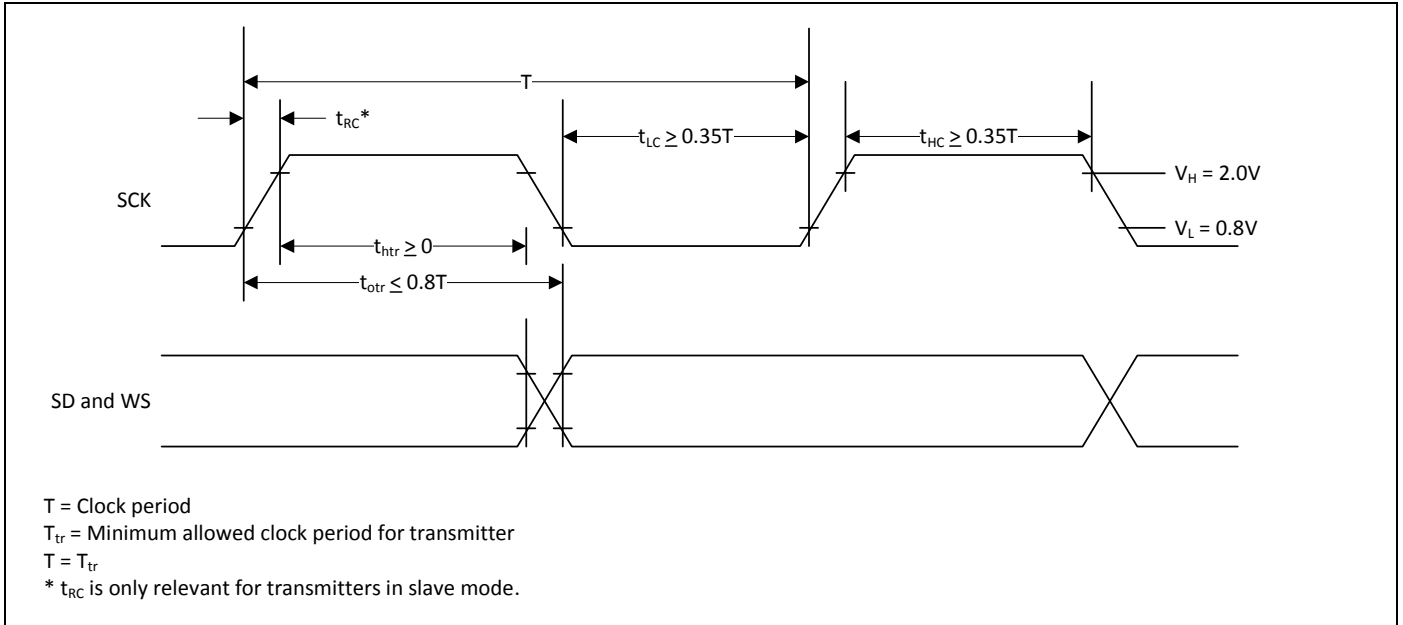
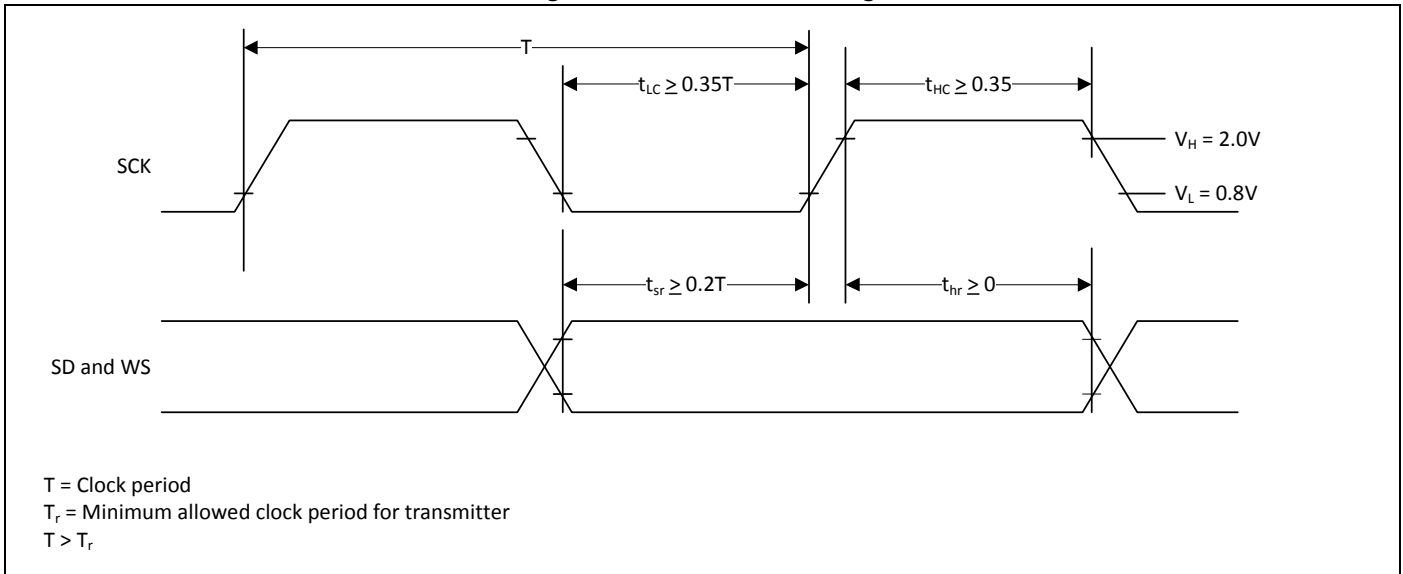

Table 28. Timing for I²S Transmitters and Receivers

	Transmitter				Receiver				Notes
	Lower Limit		Upper Limit		Lower Limit		Upper Limit		
	Min	Max	Min	Max	Min	Max	Min	Max	
Clock Period T	T_{tr}	–	–	–	T_r	–	–	–	a
Master Mode: Clock generated by transmitter or receiver									
HIGH t_{HC}	$0.35T_{tr}$	–	–	–	$0.35T_{tr}$	–	–	–	b
LOW t_{LC}	$0.35T_{tr}$	–	–	–	$0.35T_{tr}$	–	–	–	b
Slave Mode: Clock accepted by transmitter or receiver									
HIGH t_{HC}	–	$0.35T_{tr}$	–	–	–	$0.35T_{tr}$	–	–	c
LOW t_{LC}	–	$0.35T_{tr}$	–	–	–	$0.35T_{tr}$	–	–	c
Rise time t_{RC}	–	–	$0.15T_{tr}$	–	–	–	–	–	d
Transmitter									
Delay t_{dtr}	–	–	–	$0.8T$	–	–	–	–	e
Hold time t_{htr}	0	–	–	–	–	–	–	–	d
Receiver									
Setup time t_{sr}	–	–	–	–	–	$0.2T_r$	–	–	f
Hold time t_{hr}	–	–	–	–	–	0	–	–	f

- a. The system clock period T must be greater than T_{tr} and T_r because both the transmitter and receiver have to be able to handle the data transfer rate.
- b. At all data rates in master mode, the transmitter or receiver generates a clock signal with a fixed mark/space ratio. For this reason, t_{HC} and t_{LC} are specified with respect to T.
- c. In slave mode, the transmitter and receiver need a clock signal with minimum HIGH and LOW periods so that they can detect the signal. So long as the minimum periods are greater than $0.35T_r$, any clock that meets the requirements can be used.
- d. Because the delay (t_{dtr}) and the maximum transmitter speed (defined by T_{tr}) are related, a fast transmitter driven by a slow clock edge can result in t_{dtr} not exceeding t_{RC} which means t_{htr} becomes zero or negative. Therefore, the transmitter has to guarantee that t_{htr} is greater than or equal to zero, so long as the clock rise-time t_{RC} is not more than t_{RCmax} , where t_{RCmax} is not less than $0.15T_{tr}$.
- e. To allow data to be clocked out on a falling edge, the delay is specified with respect to the rising edge of the clock signal and T, always giving the receiver sufficient setup time.
- f. The data setup and hold time must not be less than the specified receiver setup and hold time.

Figure 14. I²S Transmitter Timing

Figure 15. I²S Receiver Timing

4. Mechanical Information

4.1 Package Diagrams

4.1.1 60-Pin QFN Package

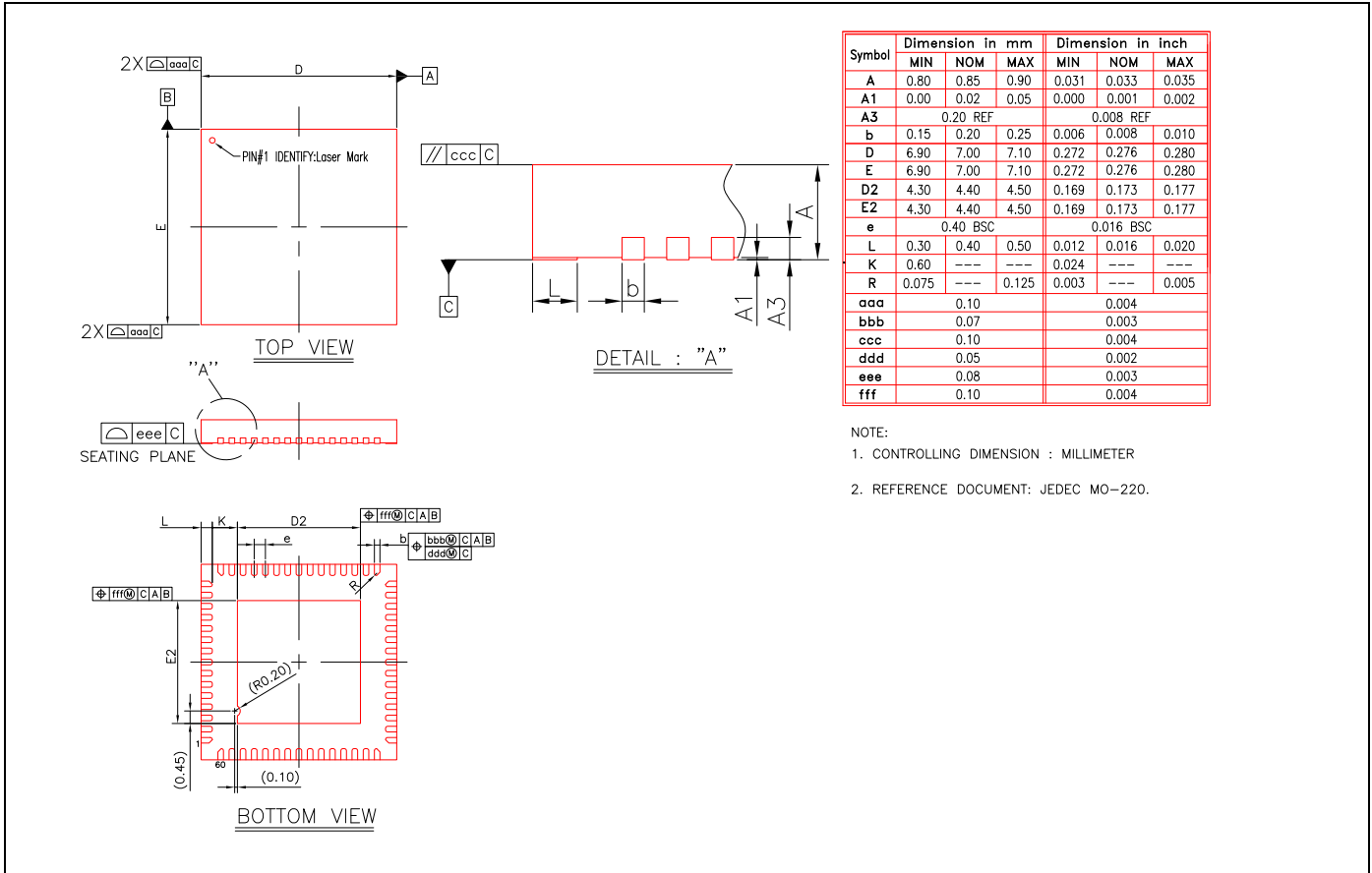
Figure 16. CYW20735 7 mm × 7 mm 60-Pin QFN Package



4.1.2 111-Pin FBGA Package

Figure 17. CYW20735 9 mm × 9 mm 111-Pin FBGA Package

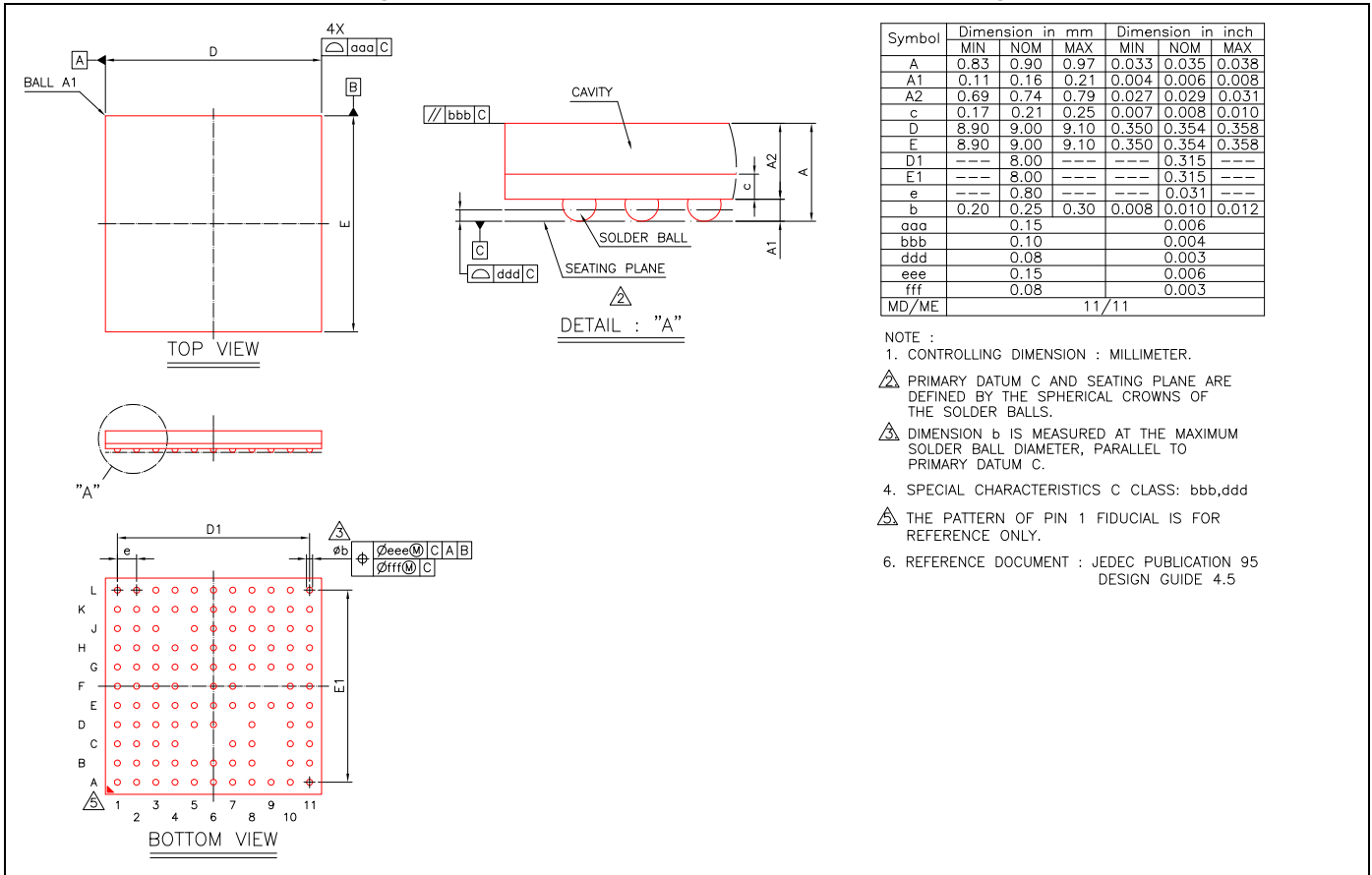

4.2 Tray Packaging Specifications

4.2.1 FBGA

The CYW20735 FBGA package and tray dimensions are annotated in [Figure 18](#) and defined in [Table 29](#) and [Table 30](#) on page 51.

Figure 18. FBGA Package and Tray Dimensions

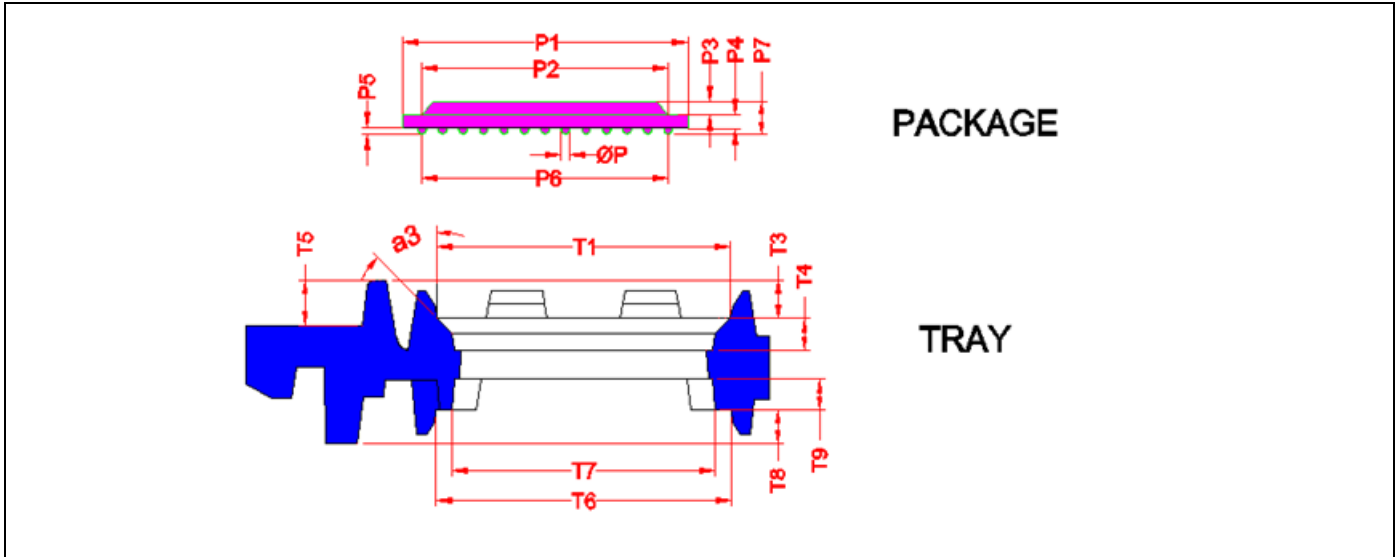

Table 29. FBGA Package Dimensions and Tolerances

Parameter	Description	Nom.	Min.	Max.	± Tol.	Unit
P1	Substrate size	9	8.9	9.1	0.1	mm
P2	Mold cap size	0	0	0	0	mm
P3	Mold cap thickness	0	0	0	0	mm
P4	Substrate thickness	0.74	0.72	0.76	0.02	mm
P5	Solder ball height	0.16	0.11	0.21	0.05	mm
P6	Total solder ball pitching distance	8	7.85	8.15	0.15	mm
φ7	Solder ball diameter	0.25	0.2	0.3	0.05	mm
P7	Total thickness (P3 + P4+ P5)	0.9	0.83	0.97	0.07	mm

Table 30. FBGA Tray Dimensions and Tolerances

Parameter	Description	Nom.	Min.	Max.	± Tol.	Unit
T1	Top pocket size	9.2	9.12	9.3	+0.1, -0.08	mm
T3	Top pocket depth	1.3	1.17	1.380	+0.08, -0.13	mm
T4	Top pocket relief depth	1.7	1.57	1.83	0.13	mm
T5	Stacking height	1.27	1.14	1.4	0.13	mm
T6	Bottom pocket size	9.32	9.19	9.45	0.13	mm
T7	Bottom pocket relief size	7.3	7.17	7.43	0.13	mm
a3	Top pocket slope wall draft angle	45	45	45	0	Degrees
T8	Bottom pocket depth	1.15	1.02	1.23	+0.08, -0.13	mm
T9	Bottom pocket relief depth	2.07	1.94	2.2	0.13	mm
T10	Packing value between two stacking trays	0.1	0.05	0.15	0.05	mm

4.2.2 QFN

The CYW20735 QFN package and tray dimensions are annotated in Figure 19 and defined in Table 31 and Table 32 on page 52.

Figure 19. QFN Package and Tray Dimensions

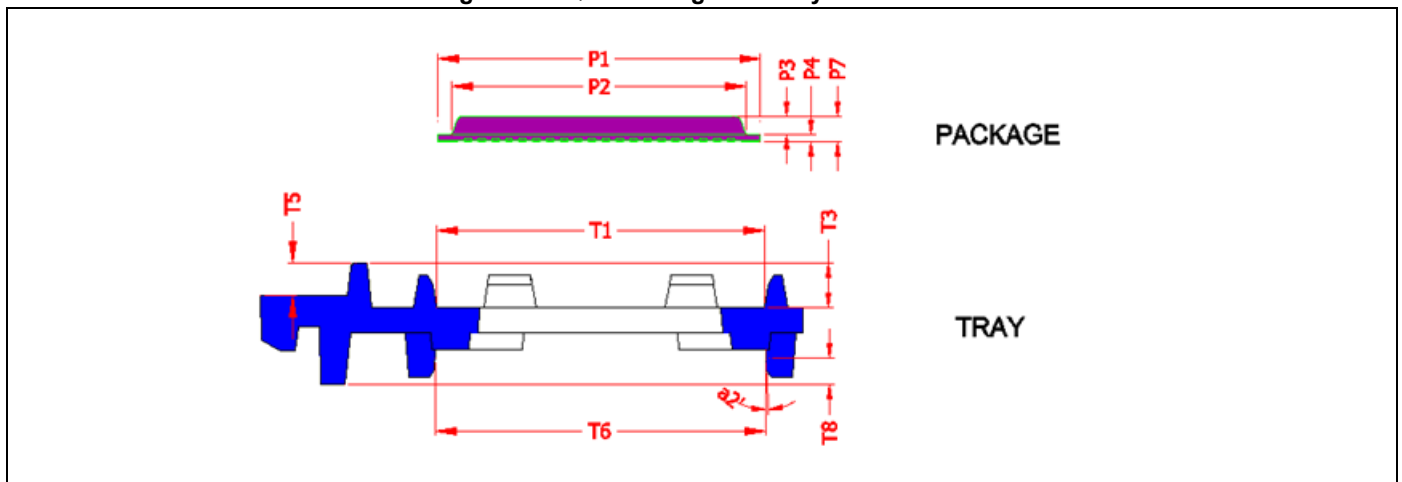

Table 31. QFN Package Dimensions and Tolerances

Parameter	Description	Nom.	Min.	Max.	± Tol.	Unit
P1	Package size	7	6.9	7.1	0.1	mm
P2	Top hat width	0	0	0	–	mm
P3	Top hat height	0	0	0	–	mm
P4	Substrate thickness	0.85	0.8	0.9	0.05	mm
P7	Total thickness (P3 + P4)	0.85	0.8	0.9	0.05	mm

Table 32. QFN Tray Dimensions and Tolerances

Parameter	Description	Nom.	Min.	Max.	± Tol.	Unit
T1	Top pocket size	7.25	7.17	7.33	0.08	mm
T3	Top pocket depth	1.75	1.5	2	0.25	mm
T5	Stacking height	2	1.87	2.13	0.13	mm
T6	Bottom pocket size	7.25	7.17	7.33	0.08	mm
T8	Bottom pocket depth	1.650	1.52	1.78	0.13	mm
a2	Bottom pocket relief wall draft angle	5	5	5	0	Degrees
T10	Packing value between two stacking trays	0.2	0.07	0.33	0.13	mm

5. Ordering Information

Table 33. Ordering Information

Part Number	Package	Ambient Operating Temperature
CYW20735PKML1G	60-pin QFN	0°C to 70°C
CYW20735KFBG	111-pin FBGA	0°C to 70°C

6. Additional Information

6.1 IoT Resources

Cypress provides a wealth of data at <http://www.cypress.com/internet-things-iot> to help you to select the right IoT device for your design, and quickly and effectively integrate the device into your design. Cypress provides customer access to a wide range of information, including technical documentation, schematic diagrams, product bill of materials, PCB layout information, and software updates. Customers can acquire technical documentation and software from the Cypress Support Community website (<https://community.cypress.com/>)

6.2 Acronyms and Abbreviations

In most cases, acronyms and abbreviations are defined upon first use. For a more complete list of acronyms and other terms used in Cypress documents, go to: <http://www.cypress.com/glossary>.

The following list of acronyms and abbreviations may appear in this document.

Term	Description
ADC	analog-to-digital converter
AFH	adaptive frequency hopping
AHB	advanced high-performance bus
APB	advanced peripheral bus
APU	audio processing unit
ARM7TDMI-S™	Acorn RISC Machine 7 Thumb instruction, Debugger, Multiplier, Ice, Synthesizable
BSC	Broadcom Serial Control
BTC	Bluetooth controller
COEX	coexistence
DFU	device firmware update
DMA	direct memory access
EBI	external bus interface
HCI	Host Control Interface
HV	high voltage
IDC	initial digital calibration
IF	intermediate frequency
IRQ	interrupt request
JTAG	Joint Test Action Group
LCU	link control unit
LDO	low drop-out
LHL	lean high land
LPO	low power oscillator
LV	LogicVision™
MIA	multiple interface agent
PDM	pulse density modulation
PLL	phase locked loop

Term	Description
PMU	power management unit
POR	power-on reset
PWM	pulse width modulation
QD	quadrature decoder
RAM	random access memory
RC oscillator	A resistor-capacitor oscillator is a circuit composed of an amplifier, which provides the output signal, and a resistor-capacitor network, which controls the frequency of the signal.
RF	radio frequency
ROM	read-only memory
RX/TX	receive, transmit
SPI	serial peripheral interface
SW	software
SWD	serial wire debug
UART	universal asynchronous receiver/transmitter
UPI	μ -processor interface
WD	watchdog

Document History Page

Document Title: CYW20735 Single-Chip Bluetooth Transceiver for Wireless Input Devices				
Document Number: 002-14881				
Revision	ECN	Orig. of Change	Submission Date	Description of Change
**	-	-	05/19/2015	20735-DS100-R Initial release
*A	-	-	10/13/2015	20735-DS101-R See the release for the applicable change description.
*B	-	-	11/09/2015	20735-DS102-R Updated: <ul style="list-style-type: none"> Table 3: "Reference Crystal Electrical Specifications," on page 21. Section 5: "Ordering Information," on page 60: updated the part number for the QFN chip.
*C	-	-	12/04/2015	20735-DS103-R Updated: <ul style="list-style-type: none"> Table 3: "Reference Crystal Electrical Specifications," on page 22. Table 9: "Core Buck Regulator," on page 45. Table 10: "Digital LDO," on page 46. Table 11: "PA LDO," on page 47. Table 12: "RF LDO," on page 48. Table 13: "Digital I/O Characteristics," on page 49. Table 14: "BLE Current Consumption," on page 49. Table 19: "UART Timing Specifications," on page 54. Added: • "Tray Packaging Specifications," on page 60. Removed: • Table 15: "BR Current Consumption," on page 48. • "Tape and Reel Packaging Specifications," on page 59.
*D	-	-	03/10/2016	20735-DS104-R Updated: <ul style="list-style-type: none"> Table 14: "BLE Current Consumption," on page 46
*E	-	-	05/26/2016	20735-DS105-R Updated: <ul style="list-style-type: none"> Table 8: "Absolute Maximum Ratings," on page 42. Table 13: "Core Buck Regulator," on page 44. Table 14: "Digital LDO," on page 45. Table 15: "PA LDO," on page 46. Table 16: "RF LDO," on page 47. Table 19: "ADC Microphone Specifications," on page 49. Added: <ul style="list-style-type: none"> "Table 9: "ESD/Latchup," on page 42. Table 10: "Environmental Ratings," on page 43. Table 11: "Recommended Operating Conditions," on page 43. Table 12: "Shutdown Voltage," on page 43. "Power-On Reset" on page 14 "Brownout Detection" on page 14
*F	5446946	UTSV	09/29/2016	Converted to Cypress template
*G	5688133	CLEU	05/22/2017	Updated Table 24. UART Timing Specifications. Added Table 28, Figure 14 and Figure 15.

Sales, Solutions, and Legal Information

Worldwide Sales and Design Support

Cypress maintains a worldwide network of offices, solution centers, manufacturer's representatives, and distributors. To find the office closest to you, visit us at [Cypress Locations](#).

Products

ARM® Cortex® Microcontrollers	cypress.com/arm
Automotive	cypress.com/automotive
Clocks & Buffers	cypress.com/clocks
Interface	cypress.com/interface
Internet of Things	cypress.com/iot
Memory	cypress.com/memory
Microcontrollers	cypress.com/mcu
PSoC	cypress.com/psoc
Power Management ICs	cypress.com/pmic
Touch Sensing	cypress.com/touch
USB Controllers	cypress.com/usb
Wireless Connectivity	cypress.com/wireless

PSoC® Solutions

[PSoC 1](#) | [PSoC 3](#) | [PSoC 4](#) | [PSoC 5LP](#) | [PSoC 6](#)

Cypress Developer Community

[Forums](#) | [WICED IoT Forums](#) | [Projects](#) | [Video](#) | [Blogs](#) | [Training](#) | [Components](#)

Technical Support

cypress.com/support

© Cypress Semiconductor Corporation, 2015-2017. This document is the property of Cypress Semiconductor Corporation and its subsidiaries, including Spansion LLC ("Cypress"). This document, including any software or firmware included or referenced in this document ("Software"), is owned by Cypress under the intellectual property laws and treaties of the United States and other countries worldwide. Cypress reserves all rights under such laws and treaties and does not, except as specifically stated in this paragraph, grant any license under its patents, copyrights, trademarks, or other intellectual property rights. If the Software is not accompanied by a license agreement and you do not otherwise have a written agreement with Cypress governing the use of the Software, then Cypress hereby grants you a personal, non-exclusive, nontransferable license (without the right to sublicense) (1) under its copyright rights in the Software (a) for Software provided in source code form, to modify and reproduce the Software solely for use with Cypress hardware products, only internally within your organization, and (b) to distribute the Software in binary code form externally to end users (either directly or indirectly through resellers and distributors), solely for use on Cypress hardware product units, and (2) under those claims of Cypress's patents that are infringed by the Software (as provided by Cypress, unmodified) to make, use, distribute, and import the Software solely for use with Cypress hardware products. Any other use, reproduction, modification, translation, or compilation of the Software is prohibited.

TO THE EXTENT PERMITTED BY APPLICABLE LAW, CYPRESS MAKES NO WARRANTY OF ANY KIND, EXPRESS OR IMPLIED, WITH REGARD TO THIS DOCUMENT OR ANY SOFTWARE OR ACCOMPANYING HARDWARE, INCLUDING, BUT NOT LIMITED TO, THE IMPLIED WARRANTIES OF MERCHANTABILITY AND FITNESS FOR A PARTICULAR PURPOSE. To the extent permitted by applicable law, Cypress reserves the right to make changes to this document without further notice. Cypress does not assume any liability arising out of the application or use of any product or circuit described in this document. Any information provided in this document, including any sample design information or programming code, is provided only for reference purposes. It is the responsibility of the user of this document to properly design, program, and test the functionality and safety of any application made of this information and any resulting product. Cypress products are not designed, intended, or authorized for use as critical components in systems designed or intended for the operation of weapons, weapons systems, nuclear installations, life-support devices or systems, other medical devices or systems (including resuscitation equipment and surgical implants), pollution control or hazardous substances management, or other uses where the failure of the device or system could cause personal injury, death, or property damage ("Unintended Uses"). A critical component is any component of a device or system whose failure to perform can be reasonably expected to cause the failure of the device or system, or to affect its safety or effectiveness. Cypress is not liable, in whole or in part, and you shall and hereby do release Cypress from any claim, damage, or other liability arising from or related to all Unintended Uses of Cypress products. You shall indemnify and hold Cypress harmless from and against all claims, costs, damages, and other liabilities, including claims for personal injury or death, arising from or related to any Unintended Uses of Cypress products.

Cypress, the Cypress logo, Spansion, the Spansion logo, and combinations thereof, WICED, PSoC, CapSense, EZ-USB, F-RAM, and Traveo are trademarks or registered trademarks of Cypress in the United States and other countries. For a more complete list of Cypress trademarks, visit cypress.com. Other names and brands may be claimed as property of their respective owners.

X-ON Electronics

Largest Supplier of Electrical and Electronic Components

Click to view similar products for [RF Microcontrollers - MCU category](#):

Click to view products by [Cypress manufacturer](#):

Other Similar products are found below :

[BCM20704UA1KFFB1G](#) [BCM20733A3KFB1G](#) [BCM20705B0KWFBG](#) [BCM20706UA1KFFB1G](#) [BCM20706UA1KFFB4G](#)
[BCM20734UA1KFFB3G](#) [BCM20736A1KML2G](#) [CYBL11172-56LQXI](#) [RY7011A0000DZ00#002](#) [CYW20732I](#) [CYW20748A0KFBGT](#)
[CYW20732E](#) [CYW20702B0KWFBG](#) [BCM20730A1KMLG](#) [CC1310F32RGZR](#) [CC1310F32RSMR](#) [ATMEGA64RFR2-ZF](#)
[BCM20735PKML1G](#) [JN5168/001,515](#) [STA2058](#) [CC1310F128RHBR](#) [ADUCRF101BCPZ128R7](#) [ADUCRF101BCPZ128](#)
[ATMEGA1284RFR2-ZU](#) [ATMEGA128RFA1-ZU](#) [ATMEGA128RFR2-ZU](#) [ATMEGA64RZAV-10MU](#) [CY8C4127LQI-BL483](#)
[ATMEGA1280R231-CU](#) [ATSAMR21E16A-MU](#) [PIC12LF1840T39A-I/ST](#) [ATMEGA64RFR2-ZUR](#) [ATMEGA128RFA1-ZUR](#)
[RFPIC12F675H-I/SS](#) [JN5169001Z](#) [CYBL11171-56LQXI](#) [CYBL11573-56LQXI](#) [CYBL10161-56LQXI](#) [EZR32LG230F64R63G-C0](#)
[ATSAMR21E18A-MU](#) [SI4010-C2-GSR](#) [EZR32WG330F256R69G-B0](#) [EZR32WG230F128R55G-B0](#) [EZR32WG230F256R55G-B0](#)
[EZR32WG330F64R55G-B0](#) [Si1063-A-GM](#) [Si1081-A-GM](#) [Si1082-A-GM](#) [Si1084-A-GM](#) [Si1085-A-GM](#)