

CY91460D series is a line of general-purpose 32-bit RISC microcontrollers designed for embedded control applications which require high-speed real-time processing, such as consumer devices and on-board vehicle systems. This series uses the FR60 CPU, which is compatible with the FR family of CPUs.

This series contains the LIN-USART and CAN controllers.

## Features

### FR60 CPU Core

- 32-bit RISC, load/store architecture, five-stage pipeline
- 16-bit fixed-length instructions (basic instructions)
- Instruction execution speed: 1 instruction per cycle
- Instructions including memory-to-memory transfer, bit manipulation, and barrel shift instructions: Instructions suitable for embedded applications
- Function entry/exit instructions and register data multi-load store instructions : Instructions supporting C language
- Register interlock function: Facilitating assembly-language coding
- Built-in multiplier with instruction-level support
  - Signed 32-bit multiplication: 5 cycles
  - Signed 16-bit multiplication: 3 cycles
- Interrupts (save PC/PS) : 6 cycles (16 priority levels)
- Harvard architecture enabling program access and data access to be performed simultaneously
- Instructions compatible with the FR family

### Internal Peripheral Resources

- General-purpose ports : Maximum 170 ports
- DMAC (DMA Controller)
  - Maximum of 5 channels able to operate simultaneously. (External to external : 1 channel)
  - 3 transfer sources (external pin/internal peripheral/software)
  - Activation source can be selected using software.
  - Addressing mode specifies full 32-bit addresses (increment/decrement/fix)
  - Transfer mode (demand transfer/burst transfer/step transfer/block transfer)
  - Fly-by transfer support (between external I/O and memory)
  - Transfer data size selectable from 8/16/32-bit
  - Multi-byte transfer enabled (by software)
  - DMAC descriptor in I/O areas (200<sub>H</sub> to 240<sub>H</sub>, 1000<sub>H</sub> to 1024<sub>H</sub>)
- A/D converter (successive approximation type)
  - 10-bit resolution: 24 channels
  - Conversion time: minimum 1  $\mu$ s
- External interrupt inputs : 14 channels
  - 8 channels shared with CAN RX or I2C pins

- Bit search module (for REALOS)
  - Function to search from the MSB (most significant bit) for the position of the first "0", "1", or changed bit in a word
- LIN-USART (full duplex double buffer): 5 channels
  - Clock synchronous/asynchronous selectable
  - Sync-break detection
  - Internal dedicated baud rate generator
- I<sup>2</sup>C bus interface (supports 400 kbps): 3 channels
  - Master/slave transmission and reception
  - Arbitration function, clock synchronization function
- CAN controller (C-CAN): 3 channels
  - Maximum transfer speed: 1 Mbps
  - 32 transmission/reception message buffers
- Stepper motor controller : 6 channels
  - 4 high current output to each channel
  - 2 synchronized PWMs per channel (8/10-bit)
- Sound generator : 1 channel
  - Tone frequency : PWM frequency divide-by-two (reload value + 1)
- Alarm comparator : 1 channel
  - Monitor external voltage
  - Generate an interrupt in case of voltage lower/higher than the defined thresholds (reference voltage)
- 16-bit PPG timer : 12 channels
- 16-bit PFM timer : 1 channel
- 16-bit reload timer: 8 channels
- 16-bit free-run timer: 8 channels (1 channel each for ICU and OCU)
- Input capture: 8 channels (operates in conjunction with the free-run timer)
- Output compare: 4 channels (operates in conjunction with the free-run timer)
- Up/Down counter: 3 channels (3\*8-bit or 1\*16-bit + 1\*8-bit)
- Watchdog timer
- Real-time clock
- Low-power consumption modes : Sleep/stop mode function
- Supply Supervisor: Low voltage detection circuit for external V<sub>DD5</sub> and internal 1.8V core voltage

- Clock supervisor
  - Monitors the sub-clock (32 kHz) and the main clock (4 MHz) , and switches to a recovery clock (CR oscillator, etc.) when the oscillations stop.
- Clock modulator
- Clock monitor
- Sub-clock calibration
  - Corrects the real-time clock timer when operating with the 32 kHz or CR oscillator
- Main oscillator stabilization timer
  - Generates an interrupt in sub-clock mode after the stabilization wait time has elapsed on the 23-bit stabilization wait time counter

- Sub-oscillator stabilization timer
  - Generates an interrupt in main clock mode after the stabilization wait time has elapsed on the 15-bit stabilization wait time counter

**Package and Technology**

- Package : QFP-208
- CMOS 0.18  $\mu\text{m}$  technology
- Power supply range 3 V to 5 V (1.8 V internal logic provided by a step-down voltage converter)
- Operating temperature range: between  $-40^{\circ}\text{C}$  and  $+105^{\circ}\text{C}$

**Contents**

<b>Product Lineup</b> .....	<b>4</b>	Operation modes .....	31
<b>Pin Assignment</b> .....	<b>7</b>	Flash access in CPU mode .....	32
CY91F465DA, CY91F467Dx .....	7	Parallel Flash programming mode .....	36
<b>Pin Description</b> .....	<b>8</b>	Poweron Sequence in parallel programming mode ..	38
CY91F465DA, CY91F467Dx .....	8	Flash Security .....	38
<b>I/O Circuit Types</b> .....	<b>16</b>	<b>Memory Space</b> .....	<b>41</b>
<b>Handling Devices</b> .....	<b>22</b>	<b>Memory Maps</b> .....	<b>42</b>
Preventing Latch-up .....	22	CY91F465DA, CY91F467Dx .....	42
Handling of unused input pins .....	22	<b>I/O Map</b> .....	<b>43</b>
Power supply pins .....	22	CY91F465DA, CY91F467Dx .....	43
Crystal oscillator circuit .....	22	Flash memory and external bus area .....	69
Notes on using external clock .....	22	<b>Interrupt Vector Table</b> .....	<b>71</b>
Mode pins (MD_x) .....	23	<b>Recommended Settings</b> .....	<b>76</b>
Notes on operating in PLL clock mode .....	23	PLL and Clockgear settings .....	76
Pull-up control .....	23	Clock Modulator settings .....	77
Notes on PS register .....	23	<b>Electrical Characteristics</b> .....	<b>83</b>
<b>Notes on Debugger</b> .....	<b>24</b>	Absolute maximum ratings .....	83
Execution of the RETI Command .....	24	Recommended operating conditions .....	86
Break function .....	24	DC characteristics .....	87
Operand break .....	24	A/D converter characteristics .....	91
<b>Block Diagram</b> .....	<b>25</b>	Alarm comparator characteristics .....	95
CY91F465DA, CY91F467Dx .....	25	FLASH memory program/erase characteristics .....	96
<b>CPU and Control Unit</b> .....	<b>26</b>	AC characteristics .....	97
Features .....	26	<b>Ordering Information</b> .....	<b>132</b>
Internal architecture .....	26	<b>Package Dimension</b> .....	<b>133</b>
Programming model .....	27	<b>Revision History</b> .....	<b>134</b>
Registers .....	28	<b>Document History</b> .....	<b>136</b>
<b>Embedded Program/data Memory (Flash)</b> .....	<b>31</b>		
Flash features .....	31		

**1. Product Lineup**

Feature	CY91V460A	CY91F465DA	CY91F467DA CY91F467DB
Max. core frequency (CLKB)	80MHz	100MHz	96MHz
Max. resource frequency (CLKP)	40MHz	50MHz	48MHz
Max. external bus freq. (CLKT)	40MHz	50MHz	48MHz
Max. CAN frequency (CLKCAN)	20MHz	50MHz	48MHz
Max. FlexRay frequency (SCLK)	-	-	-
Technology	0.35µm	0.18µm	0.18µm
Watchdog timer	yes	yes	yes
Watchdog timer (RC osc. based)	yes (disengageable)	yes	yes
Bit Search	yes	yes	yes
Reset input (INITX)	yes	yes	yes
Hardware Standby input (HSTX)	yes	no	no
Clock Modulator	yes	yes	yes
Clock Monitor	yes	yes	yes
Low Power Mode	yes	yes	yes
DMA	5 ch	5 ch	5 ch
MAC (uDSP)	no	no	no
MMU/MPU	MPU (16 ch) <sup>1)</sup>	MPU (8 ch) <sup>1)</sup>	MPU (8 ch) <sup>1)</sup>
Flash memory	Emulation SRAM 32bit read data	544 KByte	1088 KByte
Satellite Flash memory	-	no	no
Flash Protection	-	yes	yes
D-RAM	64 KByte	32 KByte	32 KByte
ID-RAM	64 KByte	16 KByte	32 KByte
Flash-Cache (Instruction cache)	16 KByte	8 KByte	8 KByte
Boot-ROM / BI-ROM	4 KByte fixed	4 KByte	4 KByte
RTC	1 ch	1 ch	1 ch
Free Running Timer	8 ch	8 ch	8 ch
ICU	8 ch	8 ch	8 ch
OCU	8 ch	4 ch	4 ch
Reload Timer	8 ch	8 ch	8 ch

Feature	CY91V460A	CY91F465DA	CY91F467DA CY91F467DB
PPG 16-bit	16 ch	12 ch	12 ch
PFM 16-bit	1 ch	1 ch	1 ch
Sound Generator	1 ch	1 ch	1 ch
Up/Down Counter (8/16-bit)	4 ch (8-bit) / 2 ch (16-bit)	3 ch (8-bit) / 1 ch (16-bit)	3 ch (8-bit) / 1 ch (16-bit)
C_CAN	6 ch (128msg)	3 ch (32msg)	3 ch (32msg)
LIN-USART	4 ch + 4 ch FIFO + 8 ch	1 ch + 4 ch FIFO	1 ch + 4 ch FIFO
I2C (400k)	4 ch	3 ch	3 ch
FR external bus	yes (32bit addr, 32bit data)	yes (26bit addr, 32bit data)	yes (26bit addr, 32bit data)
External Interrupts	16 ch	14 ch	14 ch
NMI Interrupts	1 ch	-	-
SMC	6 ch	6 ch	6 ch
LCD controller (40x4)	1 ch	-	-
ADC (10 bit)	32 ch	24 ch	24 ch
Alarm Comparator	2 ch	1 ch	1 ch
Supply Supervisor (low voltage detection)	yes	yes	yes
Clock Supervisor	yes	yes	yes
Main clock oscillator	4MHz	4MHz	4MHz
Sub clock oscillator	32kHz	32kHz	32kHz
RC Oscillator	100kHz	100kHz / 2MHz	100kHz / 2MHz
PLL	x 20	x 25	x 24
DSU4	yes	-	-
EDSU	yes (32 BP) *1	yes (16 BP) *1	yes (16 BP) *1
Supply Voltage	3V / 5V	3V / 5V	3V / 5V
Regulator	yes	yes	yes
Power Consumption	n.a.	< 1 W	< 1 W
Temperature Range (Ta)	0..70 C	-40..105 C	-40..105 C
Package	BGA660	QFP208	QFP208

Feature	CY91V460A	CY91F465DA	CY91F467DA CY91F467DB
Power on to PLL run	< 20 ms	< 20 ms	< 20 ms
Flash Download Time	n.a.	< 5 sec. typical	< 6 sec typical

\*1 : MPU channels use EDSU breakpoint registers (shared operation between MPU and EDSU).



### 3. Pin Description

#### 3.1 CY91F465DA, CY91F467Dx

Pin No.	Pin Name	I/O	I/O Circuit Type*	Function
2 to 9	P01_0 to P01_7	I/O	A	General-purpose input/output ports
	D16 to D23			Signal pins of external data bus (bit16 to bit23)
10 to 17	P00_0 to P00_7	I/O	A	General-purpose input/output ports
	D24 to D31			Signal pins of external data bus (bit24 to bit31)
18 to 25	P07_0 to P07_7	I/O	A	General-purpose input/output ports
	A0 to A7			Signal pins of external address bus (bit0 to bit7)
28 to 35	P06_0 to P06_7	I/O	A	General-purpose input/output ports
	A8 to A15			Signal pins of external address bus (bit8 to bit15)
36 to 43	P05_0 to P05_7	I/O	A	General-purpose input/output ports
	A16 to A23			Signal pins of external address bus (bit16 to bit23)
44, 45	P04_0, P04_1	I/O	A	General-purpose input/output ports
	A24, A25			Signal pins of external address bus (bit24, bit25)
46 to 49	P08_0 to P08_3	I/O	A	General-purpose input/output ports
	WRX0 to WRX3			External write strobe output pins
50	P08_4	I/O	A	General-purpose input/output port
	RDX			External read strobe output pin
51	P08_5	I/O	A	General-purpose input/output port
	BGRNTX			External bus release reception output pin
54	P08_6	I/O	A	General-purpose input/output port
	BRQ			External bus release request input pin
55	P08_7	I/O	A	General-purpose input/output port
	RDY			External ready input pin
56 to 59	P09_0 to P09_3	I/O	A	General-purpose input/output ports
	CSX0 to CSX3			Chip select output pins
60, 61	P09_6, P09_7	I/O	A	General-purpose input/output ports
	CSX6, CSX7			Chip select output pins
62	P10_1	I/O	A	General-purpose input/output port
	ASX			Address strobe output pin
63	P10_2	I/O	A	General-purpose input/output port
	BAAX			Burst address advance output pin
64	P10_3	I/O	A	General-purpose input/output port
	WEX			Write enable output pin
65	P10_4	I/O	A	General-purpose input/output port
	MCLKO			Clock output pin for memory

(Continued)



*(Continued)*

Pin No.	Pin Name	I/O	I/O Circuit Type*	Function
66	P10_5	I/O	A	General-purpose input/output port
	MCLKI			Clock input pin for memory
67	P10_6	I/O	A	General-purpose input/output port
	MCLKE			Clock enable signal pin for memory
68	MONCLK	O	M	Clock monitor pin
70	MD_2	I	G	Mode setting pins
71	MD_1	I	G	
72	MD_0	I	G	
73	INITX	I	H	External reset input pin
74	X1A	—	J2	Sub clock (oscillation) output
75	X0A	—	J2	Sub clock (oscillation) input
76	X1	—	J1	Clock (oscillation) output
77	X0	—	J1	Clock (oscillation) input
83 to 86	P24_0 to P24_3	I/O	A	General-purpose input/output ports
	INT0 to INT3			External interrupt input pins
87	P24_4	I/O	C	General-purpose input/output port
	INT4			External interrupt input pin
	SDA2			I <sup>2</sup> C bus DATA input/output pin
88	P24_5	I/O	C	General-purpose input/output port
	INT5			External interrupt input pin
	SCL2			I <sup>2</sup> C bus clock input/output pin
89	P24_6	I/O	C	General-purpose input/output port
	INT6			External interrupt input pin
	SDA3			I <sup>2</sup> C bus DATA input/output pin
90	P24_7	I/O	C	General-purpose input/output port
	INT7			External interrupt input pin
	SCL3			I <sup>2</sup> C bus clock input/output pin
91	P23_0	I/O	A	General-purpose input/output port
	RX0			RX input pin of CAN0
	INT8			External interrupt input pin
92	P23_1	I/O	A	General-purpose input/output port
	TX0			TX output pin of CAN0
93	P23_2	I/O	A	General-purpose input/output port
	RX1			RX input pin of CAN1
	INT9			External interrupt input pin

*(Continued)*

*(Continued)*

Pin No.	Pin Name	I/O	I/O Circuit Type*	Function
94	P23_3	I/O	A	General-purpose input/output port
	TX1			TX output pin of CAN1
95	P23_4	I/O	A	General-purpose input/output port
	RX2			RX input pin of CAN2
	INT10			External interrupt input pin
96	P23_5	I/O	A	General-purpose input/output port
	TX2			TX output pin of CAN2
97	P22_0	I/O	A	General-purpose input/output port
	INT12			External interrupt input pin
98	P22_2	I/O	A	General-purpose input/output port
	INT13			External interrupt input pin
99	P22_4	I/O	C	General-purpose input/output port
	SDA0			I <sup>2</sup> C bus data input/output pin
	INT14			External interrupt input pin
100	P22_5	I/O	C	General-purpose input/output port
	SCL0			I <sup>2</sup> C bus clock input/output pin
101	P20_0	I/O	A	General-purpose input/output port
	SIN2			Data input pin of USART2
	AIN0			Up/down counter input pin
102	P20_1	I/O	A	General-purpose input/output port
	SOT2			Data output pin of USART2
	BIN0			Up/down counter input pin
103	P20_2	I/O	A	General-purpose input/output port
	SCK2			Clock input/output pin of USART2
	ZIN0			Up/down counter input pin
	CK2			External clock input pin of free-run timer 2
106	P19_0	I/O	A	General-purpose input/output port
	SIN4			Data input pin of USART4
107	P19_1	I/O	A	General-purpose input/output port
	SOT4			Data output pin of USART4
108	P19_2	I/O	A	General-purpose input/output port
	SCK4			Clock input/output pin of USART4
	CK4			External clock input pin of free-run timer 4

*(Continued)*

*(Continued)*

Pin No.	Pin Name	I/O	I/O Circuit Type*	Function
109	P19_4	I/O	A	General-purpose input/output port
	SIN5			Data input pin of USART5
110	P19_5	I/O	A	General-purpose input/output port
	SOT5			Data output pin of USART5
111	P19_6	I/O	A	General-purpose input/output port
	SCK5			Clock input/output pin of USART5
	CK5			External clock input pin of free-run timer 5
112	P18_0	I/O	A	General-purpose input/output port
	SIN6			Data input pin of USART6
	AIN2			Up/down counter input pin
113	P18_1	I/O	A	General-purpose input/output port
	SOT6			Data output pin of USART6
	BIN2			Up/down counter input pin
114	P18_2	I/O	A	General-purpose input/output port
	SCK6			Clock input/output pin of USART6
	ZIN2			Up/down counter input pin
	CK6			External clock input pin of free-run timer 6
115	P18_4	I/O	A	General-purpose input/output port
	SIN7			Data input pin of USART7
	AIN3			Up/down counter input pin
116	P18_5	I/O	A	General-purpose input/output port
	SOT7			Data output pin of USART7
	BIN3			Up/down counter input pin
117	P18_6	I/O	A	General-purpose input/output port
	SCK7			Clock input/output pin of USART7
	ZIN3			Up/down counter input pin
	CK7			External clock input pin of free-run timer 7
118 to 121	P15_0 to P15_3	I/O	A	General-purpose input/output ports
	OCU0 to OCU3			Output compare output pins
	TOT0 to TOT3			Reload timer output pins
122 to 129	P14_0 to P14_7	I/O	A	General-purpose input/output ports
	ICU0 to ICU7			Input capture input pins
	TIN0 to TIN7			External trigger input pins of reload timer
	TTG8 to TTG11, TTG4/12 to TTG7/15			External trigger input pins of PPG timer

*(Continued)*

*(Continued)*

Pin No.	Pin Name	I/O	I/O Circuit Type*	Function
132 to 135	P17_4 to P17_7	I/O	A	General-purpose input/output ports
	PPG4 to PPG7			Output pins of PPG timer
136 to 139	P16_0 to P16_3	I/O	A	General-purpose input/output ports
	PPG8 to PPG11			PPG timer output pins
140	P16_4	I/O	A	General-purpose input/output port
	PPG12			Output pin of PPG timer
	SGA			SGA output pin of sound generator
141	P16_5	I/O	A	General-purpose input/output port
	PPG13			Output pin of PPG timer
	SGO			SGO output pin of sound generator
142	P16_6	I/O	A	General-purpose input/output port
	PPG14			Output pin of PPG timer
	PFM			Pulse frequency modulator output pin
143	P16_7	I/O	A	General-purpose input/output port
	PPG15			PPG timer output pin
	ATGX			A/D converter external trigger input pin
147	ALARM_0	I	N	Alarm comparator input pin
148 to 155	P29_0 to P29_7	I/O	B	General-purpose input/output ports
	AN0 to AN7			Analog input pins of A/D converter
158	P27_0	I/O	F	General-purpose input/output port
	SMC1P0			Controller output pin of Stepper motor
	AN16			Analog input pin of A/D converter
159	P27_1	I/O	F	General-purpose input/output port
	SMC1M0			Controller output pin of Stepper motor
	AN17			Analog input pin of A/D converter
160	P27_2	I/O	F	General-purpose input/output port
	SMC2P0			Controller output pin of Stepper motor
	AN18			Analog input pin of A/D converter
161	P27_3	I/O	F	General-purpose input/output port
	SMC2M0			Controller output pin of Stepper motor
	AN19			Analog input pin of A/D converter
164	P27_4	I/O	F	General-purpose input/output port
	SMC1P1			Controller output pin of Stepper motor
	AN20			Analog input pin of A/D converter

*(Continued)*

(Continued)

Pin No.	Pin Name	I/O	I/O Circuit Type*	Function
165	P27_5	I/O	F	General-purpose input/output port
	SMC1M1			Controller output pin of Stepper motor
	AN21			Analog input pin of A/D converter
166	P27_6	I/O	F	General-purpose input/output port
	SMC2P1			Controller output pin of Stepper motor
	AN22			Analog input pin of A/D converter
167	P27_7	I/O	F	General-purpose input/output port
	SMC2M1			Controller output pin of Stepper motor
	AN23			Analog input pin of A/D converter
168	P26_0	I/O	F	General-purpose input/output port
	SMC1P2			Controller output pin of Stepper motor
	AN24			Analog input pin of A/D converter
169	P26_1	I/O	F	General-purpose input/output port
	SMC1M2			Controller output pin of Stepper motor
	AN25			Analog input pin of A/D converter
170	P26_2	I/O	F	General-purpose input/output port
	SMC2P2			Controller output pin of Stepper motor
	AN26			Analog input pin of A/D converter
171	P26_3	I/O	F	General-purpose input/output port
	SMC2M2			Controller output pin of Stepper motor
	AN27			Analog input pin of A/D converter
174	P26_4	I/O	F	General-purpose input/output port
	SMC1P3			Controller output pin of Stepper motor
	AN28			Analog input pin of A/D converter
175	P26_5	I/O	F	General-purpose input/output port
	SMC1M3			Controller output pin of Stepper motor
	AN29			Analog input pin of A/D converter
176	P26_6	I/O	F	General-purpose input/output port
	SMC2P3			Controller output pin of Stepper motor
	AN30			Analog input pin of A/D converter
177	P26_7	I/O	F	General-purpose input/output port
	SMC2M3			Controller output pin of Stepper motor
	AN31			Analog input pin of A/D converter

(Continued)

(Continued)

Pin No.	Pin Name	I/O	I/O Circuit Type*	Function
178	P25_0	I/O	E	General-purpose input/output port
	SMC1P4			Controller output pin of Stepper motor
179	P25_1	I/O	E	General-purpose input/output port
	SMC1M4			Controller output pin of Stepper motor
180	P25_2	I/O	E	General-purpose input/output port
	SMC2P4			Controller output pin of Stepper motor
181	P25_3	I/O	E	General-purpose input/output port
	SMC2M4			Controller output pin of Stepper motor
184	P25_4	I/O	E	General-purpose input/output port
	SMC1P5			Controller output pin of Stepper motor
185	P25_5	I/O	E	General-purpose input/output port
	SMC1M5			Controller output pin of Stepper motor
186	P25_6	I/O	E	General-purpose input/output port
	SMC2P5			Controller output pin of Stepper motor
187	P25_7	I/O	E	General-purpose input/output port
	SMC2M5			Controller output pin of Stepper motor
189	P13_0	I/O	A	General-purpose input/output port
	DREQ0			DMA external transfer request input
190	P13_1	I/O	A	General-purpose input/output port
	DACKX0			DMA external transfer acknowledge output pin
191	P13_2	I/O	A	General-purpose input/output port
	DEOTX0			DMA external transfer EOT (End of Track) output pin
	DEOP0			DMA external transfer EOP (End of Process) output pin
192 to 199	P03_0 to P03_7	I/O	A	General-purpose input/output ports
	D0 to D7			Signal pins of external data bus (bit0 to bit7)
200 to 207	P02_0 to P02_7	I/O	A	General-purpose input/output ports
	D8 to D15			Signal pins of external data bus (bit8 to bit15)

\* : For information about the I/O circuit type, refer to "4. I/O Circuit Types".

**[Power Supply/Ground Pins]**

Pin No.	Pin Name	I/O	Function
1, 27, 53, 69, 79, 105, 131, 157, 188	VSS5	Supply	Ground pins
163, 173, 183	HVSS5		Ground pins for Stepper motor controller
26, 52	VDD35		Power supply pins for external data bus
78, 104, 130, 156	VDD5		Power supply pins
162, 172, 182	HVDD5		Power supply pins for Stepper motor controller
81, 82	VDD5R		Power supply pins for internal regulator
144	AVSS5		Analog ground pin for A/D converter
146	AVCC5		Power supply pin for A/D converter
145	AVRH5		Reference power supply pin for A/D converter
80	VCC18C		Capacitor connection pin for internal regulator

### 4. I/O Circuit Types

Type	Circuit	Remarks
A		<p>CMOS level output            (programmable <math>I_{OL} = 5\text{mA}</math>, <math>I_{OH} = -5\text{mA}</math>            and <math>I_{OL} = 2\text{mA}</math>, <math>I_{OH} = -2\text{mA}</math>)</p> <p>2 different CMOS hysteresis inputs with input shutdown function</p> <p>Automotive input with input shutdown function</p> <p>TTL input with input shutdown function</p> <p>Programmable pull-up resistor: 50k<math>\Omega</math> approx.</p>
B		<p>CMOS level output            (programmable <math>I_{OL} = 5\text{mA}</math>, <math>I_{OH} = -5\text{mA}</math>            and <math>I_{OL} = 2\text{mA}</math>, <math>I_{OH} = -2\text{mA}</math>)</p> <p>2 different CMOS hysteresis inputs with input shutdown function</p> <p>Automotive input with input shutdown function</p> <p>TTL input with input shutdown function</p> <p>Programmable pull-up resistor: 50k<math>\Omega</math> approx.</p> <p>Analog input</p>



Type	Circuit	Remarks
C	<p>pull-up control</p> <p>pull- down control</p> <p>data line</p> <p>R</p> <p>CMOS hysteresis type1</p> <p>CMOS hysteresis type2</p> <p>Automotive inputs</p> <p>TTL input</p> <p>standby control for input shutdown</p>	<p>CMOS level output (<math>I_{OL} = 3mA</math>, <math>I_{OH} = -3mA</math>)</p> <p>2 different CMOS hysteresis inputs with input shutdown function</p> <p>Automotive input with input shutdown function</p> <p>TTL input with input shutdown function</p> <p>Programmable pull-up resistor: 50kΩ approx.</p>
D	<p>pull-up control</p> <p>pull- down control</p> <p>data line</p> <p>R</p> <p>CMOS hysteresis type1</p> <p>CMOS hysteresis type2</p> <p>Automotive inputs</p> <p>TTL input</p> <p>standby control for input shutdown</p> <p>analog input</p>	<p>CMOS level output (<math>I_{OL} = 3mA</math>, <math>I_{OH} = -3mA</math>)</p> <p>2 different CMOS hysteresis inputs with input shutdown function</p> <p>Automotive input with input shutdown function</p> <p>TTL input with input shutdown function</p> <p>Programmable pull-up resistor: 50kΩ approx.</p> <p>Analog input</p>

Type	Circuit	Remarks
E	<p>pull-up control</p> <p>driver strength control</p> <p>data line</p> <p>pull-down control</p> <p>R</p> <p>CMOS hysteresis type1</p> <p>CMOS hysteresis type2</p> <p>Automotive inputs</p> <p>TTL input</p> <p>standby control for input shutdown</p>	<p>CMOS level output            (programmable <math>I_{OL} = 5\text{mA}</math>, <math>I_{OH} = -5\text{mA}</math>            and <math>I_{OL} = 2\text{mA}</math>, <math>I_{OH} = -2\text{mA}</math>,            and <math>I_{OL} = 30\text{mA}</math>, <math>I_{OH} = -30\text{mA}</math>)</p> <p>2 different CMOS hysteresis inputs with input shutdown function</p> <p>Automotive input with input shutdown function</p> <p>TTL input with input shutdown function</p> <p>Programmable pull-up resistor: 50kΩ approx.</p>
F	<p>pull-up control</p> <p>driver strength control</p> <p>data line</p> <p>pull-down control</p> <p>R</p> <p>CMOS hysteresis type1</p> <p>CMOS hysteresis type2</p> <p>Automotive inputs</p> <p>TTL input</p> <p>standby control for input shutdown</p> <p>analog input</p>	<p>CMOS level output            (programmable <math>I_{OL} = 5\text{mA}</math>, <math>I_{OH} = -5\text{mA}</math>            and <math>I_{OL} = 2\text{mA}</math>, <math>I_{OH} = -2\text{mA}</math>,            and <math>I_{OL} = 30\text{mA}</math>, <math>I_{OH} = -30\text{mA}</math>)</p> <p>2 different CMOS hysteresis inputs with input shutdown function</p> <p>Automotive input with input shutdown function</p> <p>TTL input with input shutdown function</p> <p>Programmable pull-up resistor: 50kΩ approx.</p> <p>Analog input</p>

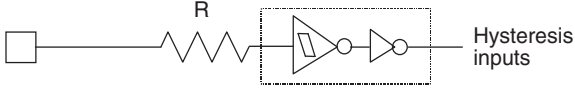
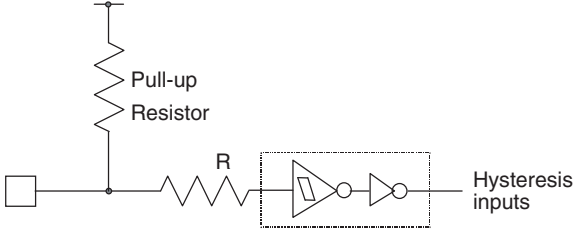
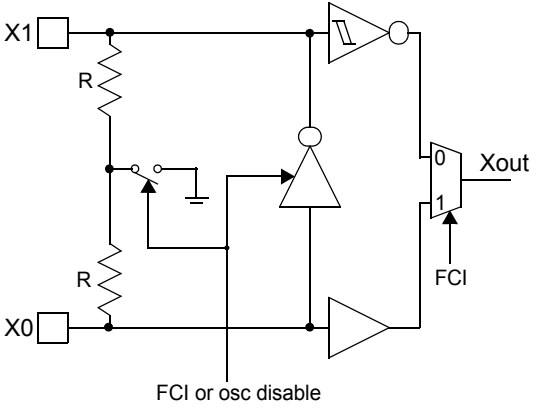
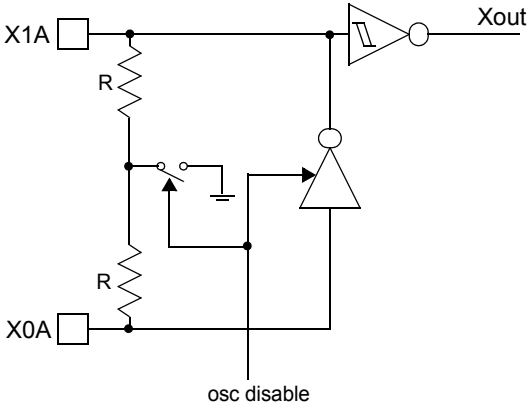
Type	Circuit	Remarks
G		<p>Mask ROM and EVA device: CMOS Hysteresis input pin</p> <p>Flash device: CMOS input pin 12 V withstand (for MD [2:0])</p>
H		<p>CMOS Hysteresis input pin Pull-up resistor value: 50 kΩ approx.</p>
J1		<p>High-speed oscillation circuit:</p> <ul style="list-style-type: none"> <li>• Programmable between oscillation mode (external crystal or resonator connected to X0/X1 pins) and Fast external Clock Input (FCI) mode (external clock connected to X0 pin)</li> <li>• Feedback resistor = approx. 2 * 0.5 MΩ. Feedback resistor is grounded in the center when the oscillator is disabled or in FCI mode.</li> </ul>
J2		<p>Low-speed oscillation circuit:</p> <ul style="list-style-type: none"> <li>• Feedback resistor = approx. 2 * 5 MΩ. Feedback resistor is grounded in the center when the oscillator is disabled.</li> </ul>

Type	Circuit	Remarks
K	<p>pull-up control</p> <p>driver strength control</p> <p>data line</p> <p>pull-down control</p> <p>R</p> <p>CMOS hysteresis type1</p> <p>CMOS hysteresis type2</p> <p>Automotive inputs</p> <p>TTL input</p> <p>standby control for input shutdown</p> <p>LCD SEG/COM</p>	<p>CMOS level output (programmable <math>I_{OL} = 5\text{mA}</math>, <math>I_{OH} = -5\text{mA}</math> and <math>I_{OL} = 2\text{mA}</math>, <math>I_{OH} = -2\text{mA}</math>)</p> <p>2 different CMOS hysteresis inputs with input shutdown function</p> <p>Automotive input with input shutdown function</p> <p>TTL input with input shutdown function</p> <p>Programmable pull-up resistor: 50kΩ approx.</p> <p>LCD SEG/COM output</p>
L	<p>pull-up control</p> <p>driver strength control</p> <p>data line</p> <p>pull-down control</p> <p>R</p> <p>CMOS hysteresis type1</p> <p>CMOS hysteresis type2</p> <p>Automotive inputs</p> <p>TTL input</p> <p>standby control for input shutdown</p> <p>VLCD</p>	<p>CMOS level output (programmable <math>I_{OL} = 5\text{mA}</math>, <math>I_{OH} = -5\text{mA}</math> and <math>I_{OL} = 2\text{mA}</math>, <math>I_{OH} = -2\text{mA}</math>)</p> <p>2 different CMOS hysteresis inputs with input shutdown function</p> <p>Automotive input with input shutdown function</p> <p>TTL input with input shutdown function</p> <p>Programmable pull-up resistor: 50kΩ approx.</p> <p>Analog input</p> <p>LCD Voltage input</p>

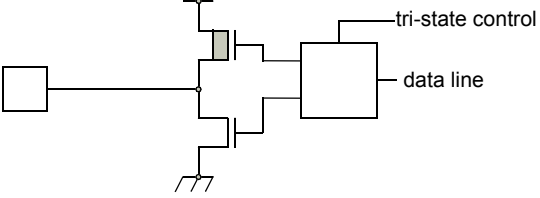
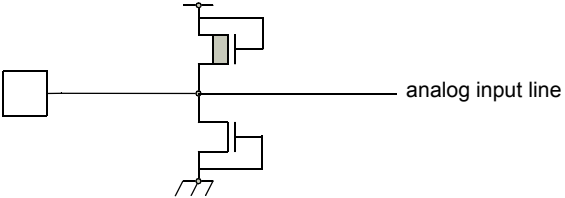
Type	Circuit	Remarks
M		<p>CMOS level tri-state output  <math>(I_{OL} = 5\text{mA}, I_{OH} = -5\text{mA})</math></p>
N		<p>Analog input pin with protection</p>

## 5. Handling Devices

### 5.1 Preventing Latch-up

Latch-up may occur in a CMOS IC if a voltage higher than ( $V_{DD5}$ ,  $V_{DD35}$  or  $HV_{DD5}$ ) or less than ( $V_{SS5}$  or  $HV_{SS5}$ ) is applied to an input or output pin or if a voltage exceeding the rating is applied between the power supply pins and ground pins. If latch-up occurs, the power supply current increases rapidly, sometimes resulting in thermal breakdown of the device. Therefore, be very careful not to apply voltages in excess of the absolute maximum ratings.

### 5.2 Handling of Unused Input Pins

If unused input pins are left open, abnormal operation may result. Any unused input pins should be connected to pull-up or pull-down resistor (2K $\Omega$  to 10K $\Omega$ ) or enable internal pullup or pulldown resistors (PPER/PPCR) before the input enable (PORTEN) is activated by software. The mode pins MD\_x can be connected to  $V_{SS5}$  or  $V_{DD5}$  directly. Unused ALARM input pins can be connected to  $AV_{SS5}$  directly.

### 5.3 Power Supply Pins

In CY91460D series, devices including multiple power supply pins and ground pins are designed as follows; pins necessary to be at the same potential are interconnected internally to prevent malfunctions such as latch-up. All of the power supply pins and ground pins must be externally connected to the power supply and ground respectively in order to reduce unnecessary radiation, to prevent strobe signal malfunctions due to the ground level rising and to follow the total output current ratings. Furthermore, the power supply pins and ground pins of the CY91460D series must be connected to the current supply source via a low impedance.

It is also recommended to connect a ceramic capacitor of approximately 0.1  $\mu$ F as a bypass capacitor between power supply pin and ground pin near this device.

This series has a built-in step-down regulator. Connect a bypass capacitor of 4.7  $\mu$ F (use a X7R ceramic capacitor) to VCC18C pin for the regulator.

### 5.4 Crystal Oscillator Circuit

Noise in proximity to the X0 (X0A) and X1 (X1A) pins can cause the device to operate abnormally. Printed circuit boards should be designed so that the X0 (X0A) and X1 (X1A) pins, and crystal oscillator, as well as bypass capacitors connected to ground, are located near the device and ground.

It is recommended that the printed circuit board layout be designed such that the X0 and X1 pins or X0A and X1A pins are surrounded by ground plane for the stable operation.

Please request the oscillator manufacturer to evaluate the oscillational characteristics of the crystal and this device.

### 5.5 Notes on Using External Clock

When using the external clock, it is necessary to simultaneously supply the X0 (X0A) and the X1 (X1A) pins. In the described combination, X1 (X1A) should be supplied with a clock signal which has the opposite phase to the X0 (X0A) pins. At X0 and X1, a frequency up to 16 MHz is possible.

#### Example of Using Opposite Phase Supply

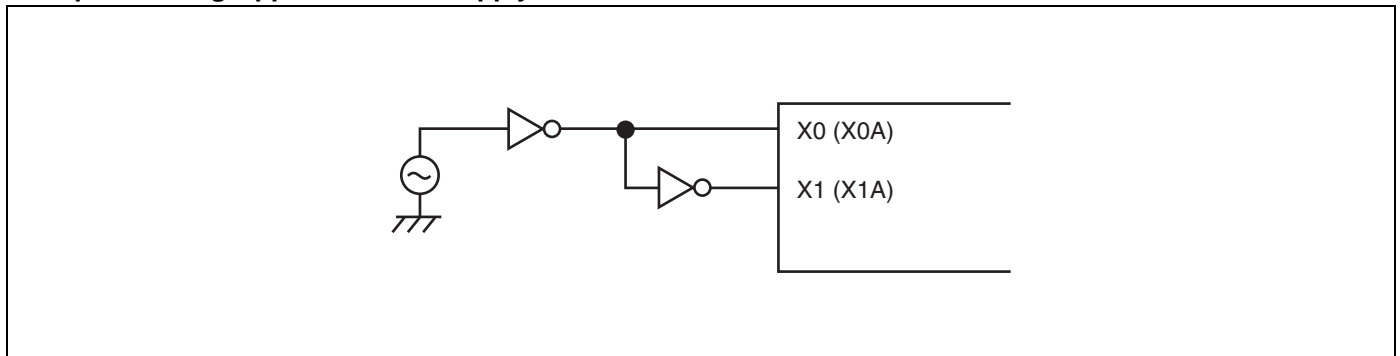

### 5.6 Mode Pins (MD\_x)

These pins should be connected directly to the power supply or ground pins. To prevent the device from entering test mode accidentally due to noise, minimize the lengths of the patterns between each mode pin and power supply pin or ground pin on the printed circuit board as possible and connect them with low impedance.

### 5.7 Notes on Operating in PLL Clock Mode

If the oscillator is disconnected or the clock input stops when the PLL clock is selected, the microcontroller may continue to operate at the free-running frequency of the self-oscillating circuit of the PLL. However, this self-running operation cannot be guaranteed.

### 5.8 Pull-up Control

The AC standard is not guaranteed in case a pull-up resistor is connected to the pin serving as an external bus pin.

### 5.9 Notes on PS Register

As the PS register is processed in advance by some instructions, when the debugger is being used, the exception handling may result in execution breaking in an interrupt handling routine or the displayed values of the flags in the PS register being updated.

As the microcontroller is designed to carry out reprocessing correctly upon returning from such an EIT event, the operation before and after the EIT always proceeds according to specification.

**The following behavior may occur if any of the following occurs in the instruction immediately after a DIV0U/DIV0S instruction:**

- (a) a user interrupt or NMI is accepted;
- (b) single-step execution is performed;
- (c) execution breaks due to a data event or from the emulator menu.
  - 1. D0 and D1 flags are updated in advance.
  - 2. An EIT handling routine (user interrupt/NMI or emulator) is executed.
  - 3. Upon returning from the EIT, the DIV0U/DIV0S instruction is executed and the D0 and D1 flags are updated to the same values as those in 1.

**The following behavior occurs when an ORCCR, STILM, MOV Ri,PS instruction is executed to enable a user interrupt or NMI source while that interrupt is in the active state.**

- 1. The PS register is updated in advance.
- 2. An EIT handling routine (user interrupt/NMI or emulator) is executed.
- 3. Upon returning from the EIT, the above instructions are executed and the PS register is updated to the same value as in 1.

## **6. Notes on Debugger**

### **6.1 Execution of the RETI Command**

If single-step execution is used in an environment where an interrupt occurs frequently, the corresponding interrupt handling routine will be executed repeatedly to the exclusion of other processing. This will prevent the main routine and the handlers for low priority level interrupts from being executed (For example, if the time-base timer interrupt is enabled, stepping over the RETI instruction will always break on the first line of the time-base timer interrupt handler).

Disable the corresponding interrupts when the corresponding interrupt handling routine no longer needs debugging.

### **6.2 Break Function**

If the range of addresses that cause a hardware break (including event breaks) is set to the address of the current system stack pointer or to an area that contains the stack pointer, execution will break after each instruction regardless of whether the user program actually contains data access instructions.

To prevent this, do not set (word) access to the area containing the address of the system stack pointer as the target of the hardware break (including an event breaks).

### **6.3 Operand Break**

It may cause malfunctions if a stack pointer exists in the area which is set as the DSU operand break. Do not set the access to the areas containing the address of system stack pointer as a target of data event break.



## 7. Block Diagram

### 7.1 CY91F465DA, CY91F467Dx

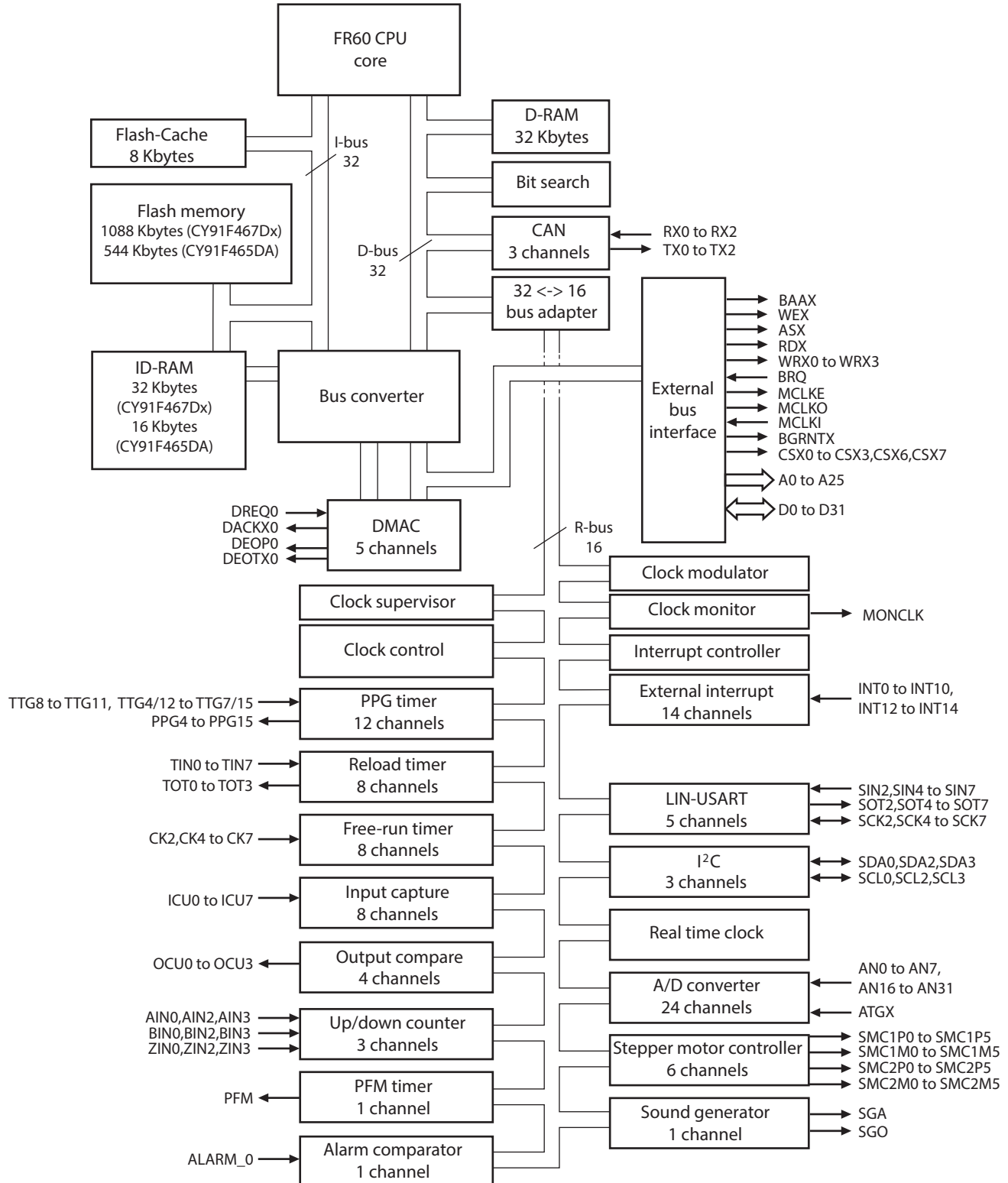

## 8. CPU and Control Unit

The FR family CPU is a high performance core that is designed based on the RISC architecture with advanced instructions for embedded applications.

### 8.1 Features

- Adoption of RISC architecture  
Basic instruction: 1 instruction per cycle
- General-purpose registers: 32-bit × 16 registers
- 4 Gbytes linear memory space
- Multiplier installed  
32-bit × 32-bit multiplication: 5 cycles  
16-bit × 16-bit multiplication: 3 cycles
- Enhanced interrupt processing function  
Quick response speed (6 cycles)  
Multiple-interrupt support  
Level mask function (16 levels)
- Enhanced instructions for I/O operation  
Memory-to-memory transfer instruction  
Bit processing instruction  
Basic instruction word length: 16 bits
- Low-power consumption  
Sleep mode/stop mode

### 8.2 Internal Architecture

- The FR family CPU uses the Harvard architecture in which the instruction bus and data bus are independent of each other.
- A 32-bit ↔ 16-bit buffer is connected to the 32-bit bus (D-bus) to provide an interface between the CPU and peripheral resources.
- A Harvard ↔ Princeton bus converter is connected to both the I-bus and D-bus to provide an interface between the CPU and the bus controller.

### 8.3 Programming Model

#### 8.3.1 Basic Programming Model

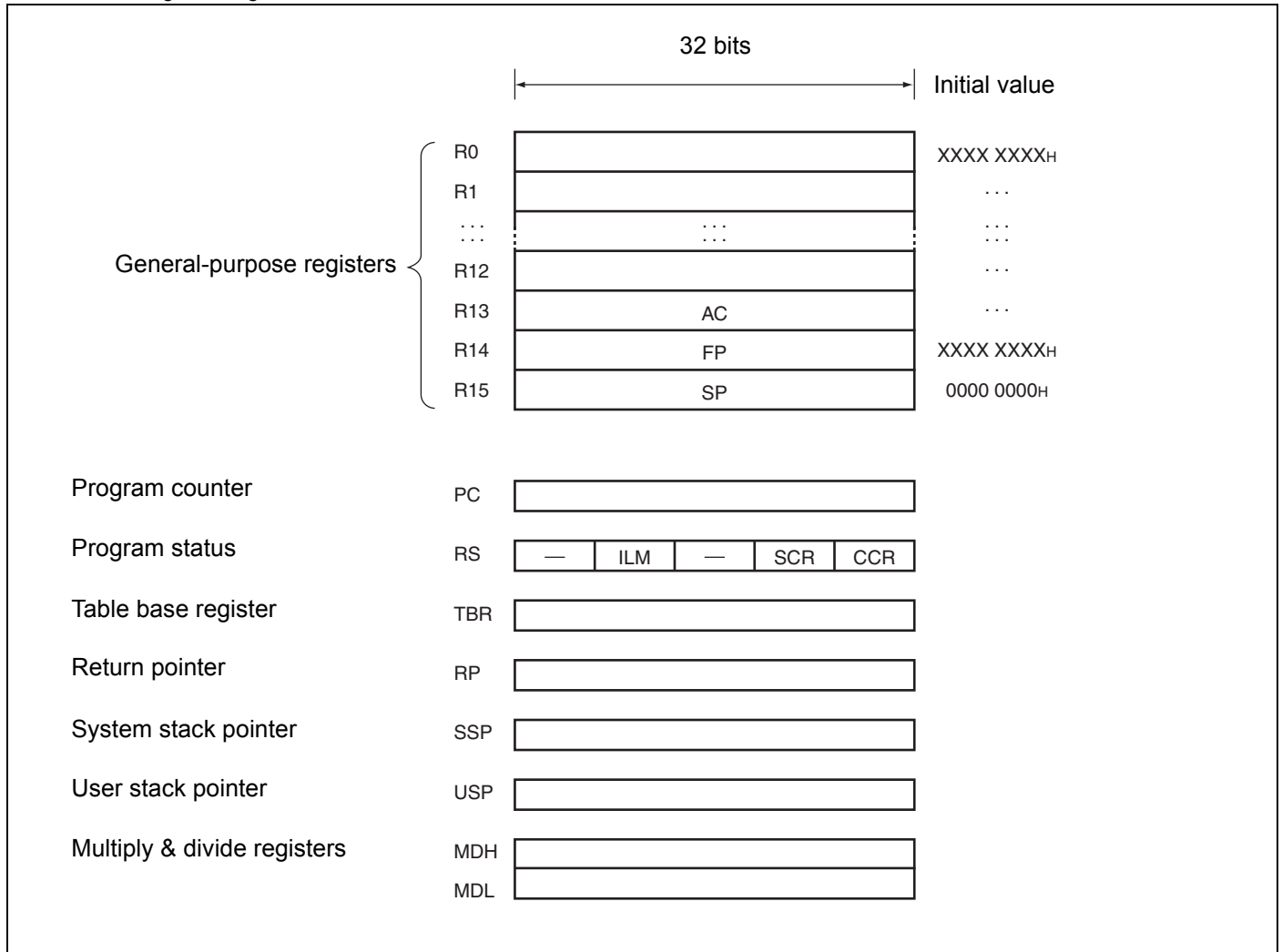

## 8.4 Registers

### 8.4.1 General-purpose Register

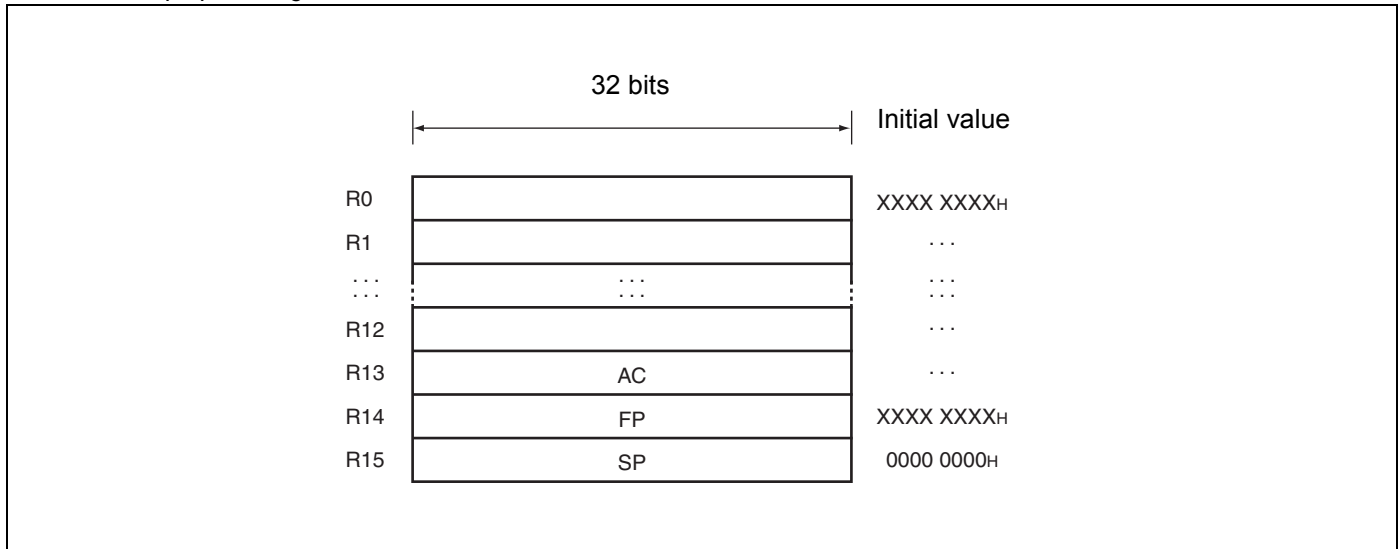

Registers R0 to R15 are general-purpose registers. These registers can be used as accumulators for computation operations and as pointers for memory access.

Of the 16 registers, enhanced commands are provided for the following registers to enable their use for particular applications.

R13 : Virtual accumulator

R14 : Frame pointer

R15 : Stack pointer

Initial values at reset are undefined for R0 to R14. The value for R15 is 00000000<sub>H</sub> (SSP value).

### 8.4.2 PS (Program Status)

This register holds the program status, and is divided into three parts, ILM, SCR, and CCR.

All undefined bits (-) in the diagram are reserved bits. The read values are always "0". Write access to these bits is invalid.

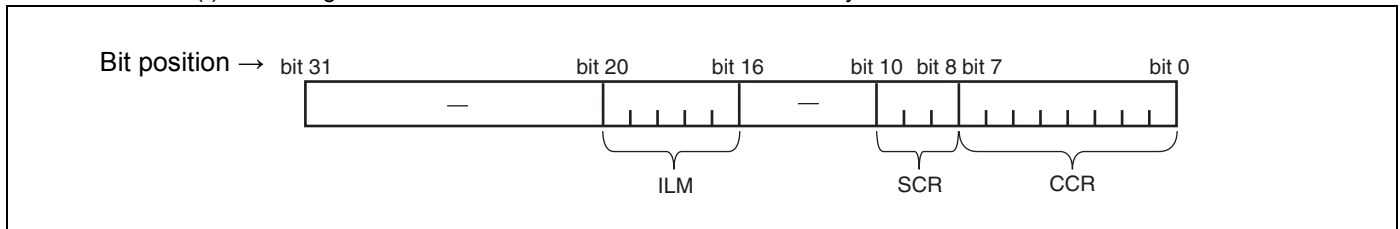

8.4.3 CCR (Condition Code Register)

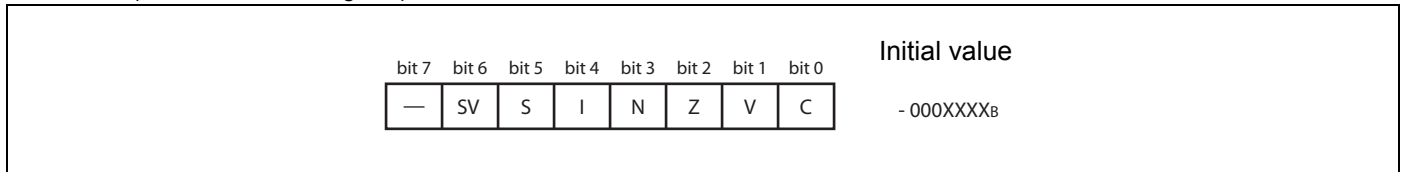

- SV : Supervisor flag
- S : Stack flag
- I : Interrupt enable flag
- N : Negative enable flag
- Z : Zero flag
- V : Overflow flag
- C : Carry flag

8.4.4 SCR (System Condition Register)

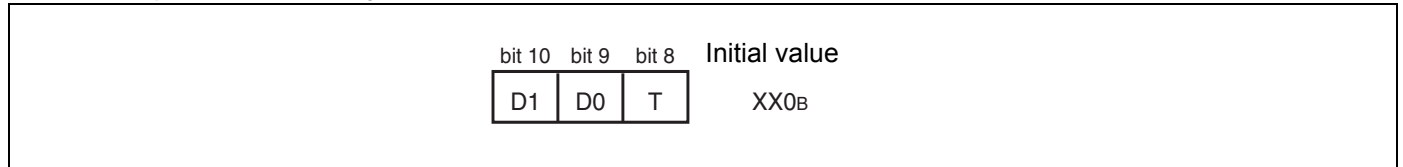

Flag for step division (D1, D0)

This flag stores interim data during execution of step division.

Step trace trap flag (T)

This flag indicates whether the step trace trap is enabled or disabled.

The step trace trap function is used by emulators. When an emulator is in use, it cannot be used in execution of user programs.

8.4.5 ILM (Interrupt Level Mask Register)

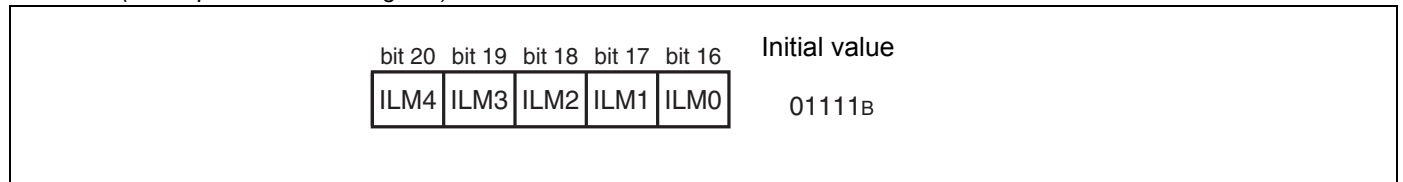

This register stores interrupt level mask values, and the values stored in ILM4 to ILM0 are used for level masking.

The register is initialized to value “01111<sub>B</sub>” at reset.

8.4.6 PC (Program Counter)

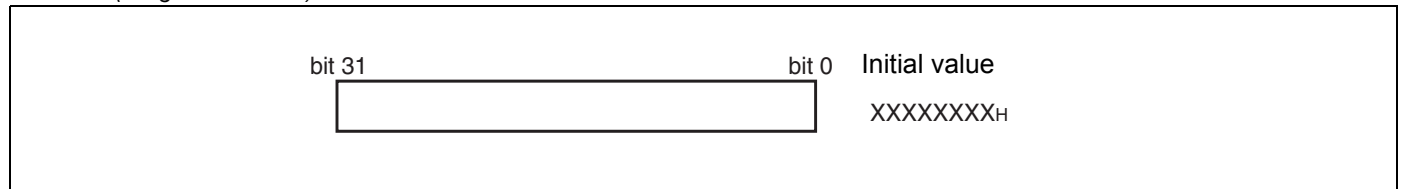

The program counter indicates the address of the instruction that is being executed.

The initial value at reset is undefined.

8.4.7 TBR (Table Base Register)



The table base register stores the starting address of the vector table used in EIT processing. The initial value at reset is 000FFC00H.

8.4.8 RP (Return Pointer)

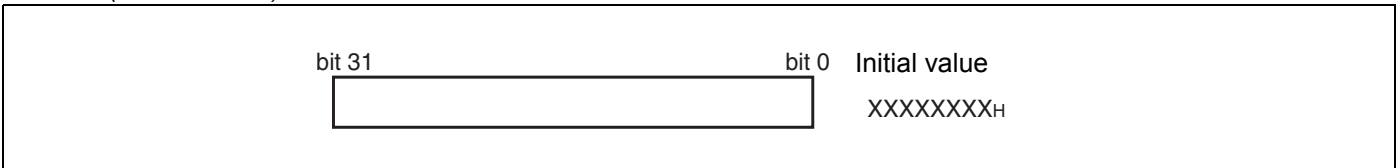

The return pointer stores the address for return from subroutines. During execution of a CALL instruction, the PC value is transferred to this RP register. During execution of a RET instruction, the contents of the RP register are transferred to PC. The initial value at reset is undefined.

8.4.9 USP (User Stack Pointer)

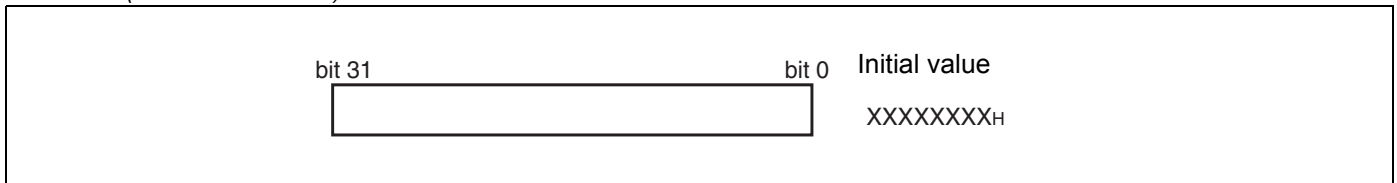

The user stack pointer, when the S flag is "1", this register functions as the R15 register.

- The USP register can also be explicitly specified. The initial value at reset is undefined.
- This register cannot be used with RETI instructions.

8.4.10 Multiply & Divide Registers

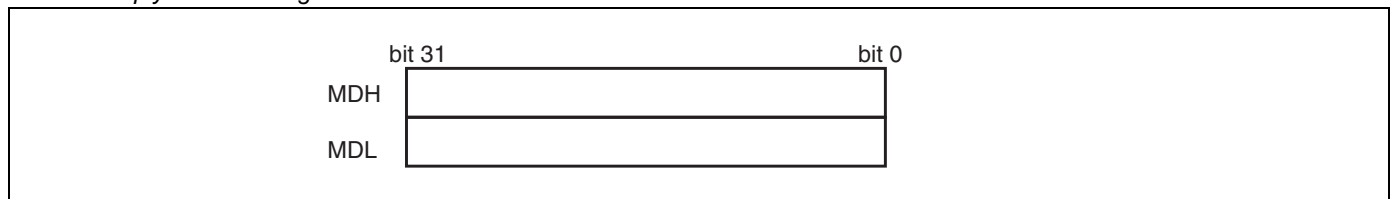

These registers are for multiplication and division, and are each 32 bits in length. The initial value at reset is undefined.

## 9. Embedded Program/data Memory (Flash)

### 9.1 Flash Features

- CY91F467Dx: 1088 Kbytes ( $16 \times 64$  Kbytes +  $8 \times 8$  Kbytes) = 8.5 Mbits
- CY91F465DA: 544 Kbytes ( $8 \times 64$  Kbytes +  $4 \times 8$  Kbytes) = 4.25 Mbits
- Programmable wait state for read/write access
- Flash and Boot security with security vector at 0x0014:8000 - 0x0014:800F
- Boot security
- Basic specification: Same as CYM29LV400TC (except size and part of sector configuration)

### 9.2 Operation Modes

1. 64-bit CPU mode (available on CY91F467Dx only) :
  - CPU reads and executes programs in word (32-bit) length units.
  - Flash writing is not possible.
  - Actual Flash Memory access is performed in d-word (64-bit) length units.
2. 32-bit CPU mode :
  - CY91F465DA: CPU reads and executes programs in word (32-bit) length units.
  - CY91F467Dx: CPU reads, writes and executes programs in word (32-bit) length units.
  - Actual Flash Memory access is performed in word (32-bit) length units.
3. 16-bit CPU mode :
  - CPU reads and writes in half-word (16-bit) length units.
  - Program execution from the Flash is not possible.
  - Actual Flash Memory access is performed in half-word (16-bit) length units.

**Note:** The operation mode of the flash memory can be selected using a Boot-ROM function. The function start address is 0xBF60. The parameter description is given in the Hardware Manual in chapter 54.6 “Flash Access Mode Switching”.

### 9.3 Flash Access in CPU Mode

#### 9.3.1 Flash Configuration

##### Flash Memory Map CY91F467Dx

Address									
0014:FFFFh 0014:C000h	SA6 (8KB)				SA7 (8KB)				ROMS7
0014:BFFFh 0014:8000h	SA4 (8KB)				SA5 (8KB)				
0014:7FFFh 0014:4000h	SA2 (8KB)				SA3 (8KB)				
0014:3FFFh 0014:0000h	SA0 (8KB)				SA1 (8KB)				
0013:FFFFh 0012:0000h	SA22 (64KB)				SA23 (64KB)				ROMS6
0011:FFFFh 0010:0000h	SA20 (64KB)				SA21 (64KB)				
000F:FFFFh 000E:0000h	SA18 (64KB)				SA19 (64KB)				ROMS5
000D:FFFFh 000C:0000h	SA16 (64KB)				SA17 (64KB)				ROMS4
000B:FFFFh 000A:0000h	SA14 (64KB)				SA15 (64KB)				ROMS3
0009:FFFFh 0008:0000h	SA12 (64KB)				SA13 (64KB)				ROMS2
0007:FFFFh 0006:0000h	SA10 (64KB)				SA11 (64KB)				ROMS1
0005:FFFFh 0004:0000h	SA8 (64KB)				SA9 (64KB)				ROMS0
	addr+0	addr+1	addr+2	addr+3	addr+4	addr+5	addr+6	addr+7	
16bit read/write	dat[31:16]		dat[15:0]		dat[31:16]		dat[15:0]		
32bit read/write	dat[31:0]				dat[31:0]				
64bit read	dat[63:0]								



Flash Memory Map CY91F465DA

Addr									
0014:FFFFh 0014:C000h	SA6 (8KB)				SA7 (8KB)				ROMS7
0014:BFFFh 0014:8000h	SA4 (8KB)				SA5 (8KB)				
0014:7FFFh 0014:4000h	SA2 (8KB)				SA3 (8KB)				
0014:3FFFh 0014:0000h	SA0 (8KB)				SA1 (8KB)				
0013:FFFFh 0012:0000h	SA22 (64KB)				SA23 (64KB)				ROMS6
0011:FFFFh 0010:0000h	SA20 (64KB)				SA21 (64KB)				
000F:FFFFh 000E:0000h	SA18 (64KB)				SA19 (64KB)				ROMS5
000D:FFFFh 000C:0000h	SA16 (64KB)				SA17 (64KB)				ROMS4
000B:FFFFh 000A:0000h	SA14 (64KB)				SA15 (64KB)				ROMS3
0009:FFFFh 0008:0000h	SA12 (64KB)				SA13 (64KB)				ROMS2
0007:FFFFh 0006:0000h	SA10 (64KB)				SA11 (64KB)				ROMS1
0005:FFFFh 0004:0000h	SA8 (64KB)				SA9 (64KB)				ROMS0
	addr+0	addr+1	addr+2	addr+3	addr+4	addr+5	addr+6	addr+7	
16bit read/write	dat[31:16]		dat[15:0]		dat[31:16]		dat[15:0]		
32bit read	dat[31:0]				dat[31:0]				
Legend	Memory not available in this area				Memory available in this area				

**9.3.2 Flash Access Timing Settings in CPU Mode**

The following tables list all settings for a given maximum Core Frequency (through the setting of CLKB or maximum clock modulation) for Flash read and write access.

**Flash Read Timing Settings (Synchronous Read)**

Core Clock (CLKB)	ATD	ALEH	EQ	WEXH	WTC	Remark
to 24 MHz	0	0	0	-	1	
to 48 MHz	0	0	1	-	2	
to 96 MHz	1	1	3	-	4	
to 100 MHz	1	1	3	-	4	not available on CY91F467Dx

**Flash Write Timing Settings (Synchronous Write)**

Core Clock (CLKB)	ATD	ALEH	EQ	WEXH	WTC	Remark
to 32 MHz	1	-	-	0	4	
to 48 MHz	1	-	-	0	5	
to 64 MHz	1	-	-	0	6	
to 96 MHz	1	-	-	0	7	
to 100 MHz	1	-	-	0	7	not available on CY91F467Dx

### 9.3.3 Address Mapping from CPU to Parallel Programming Mode

The following tables show the calculation from CPU addresses to flash macro addresses which are used in parallel programming.

#### Address Mapping CY91F467Dx

CPU Address (addr)	Condition	Flash Sectors	FA (flash address) Calculation
14:0000h to 14:FFFFh	addr[2]==0	SA0, SA2, SA4, SA6 (8 Kbyte)	FA := addr - addr%00:4000h + (addr%00:4000h)/2 - (addr/2)%4 + addr%4 - 05:0000h
14:0000h to 14:FFFFh	addr[2]==1	SA1, SA3, SA5, SA7 (8 Kbyte)	FA := addr - addr%00:4000h + (addr%00:4000h)/2 - (addr/2)%4 + addr%4 - 05:0000h + 00:2000h
04:0000h to 13:FFFFh	addr[2]==0	SA8, SA10, SA12, SA14, SA16, SA18, SA20, SA22 (64 Kbyte)	FA := addr - addr%02:0000 + (addr%02:0000h)/2 - (addr/2)%4 + addr%4 + 0C:0000h
04:0000h to 13:FFFFh	addr[2]==1	SA9, SA11, SA13, SA15, SA17, SA19, SA21, SA23 (64 Kbyte)	FA := addr - addr%02:0000h + (addr%02:0000h)/2 - (addr/2)%4 + addr%4 + 0C:0000h + 01:0000h

Note: FA result is without 20:0000h offset for parallel Flash programming.

Set offset by keeping FA[21] = 1 as described in section "Parallel Flash programming mode".

#### Address Mapping CY91F465DA

CPU Address (addr)	Condition	Flash Sectors	FA (flash address) Calculation
14:8000h to 14:FFFFh	addr[2]==0	SA4, SA6 (8 Kbyte)	FA := addr - addr%00:4000h + (addr%00:4000h)/2 - (addr/2)%4 + addr%4 - 0D:0000h
14:8000h to 14:FFFFh	addr[2]==1	SA5, SA7 (8 Kbyte)	FA := addr - addr%00:4000h + (addr%00:4000h)/2 - (addr/2)%4 + addr%4 - 0D:0000h + 00:2000h
08:0000h to 0F:FFFFh	addr[2]==0	SA12, SA14, SA16, SA18 (64 Kbyte)	FA := addr - addr%02:0000 + (addr%02:0000h)/2 - (addr/2)%4 + addr%4 + 00:0000h
08:0000h to 0F:FFFFh	addr[2]==1	SA13, SA15, SA17, SA19 (64 Kbyte)	FA := addr - addr%02:0000h + (addr%02:0000h)/2 - (addr/2)%4 + addr%4 - 00:0000h + 01:0000h

Note: FA result is without 10:0000h offset for parallel Flash programming.

Set offset by keeping FA[20] = 1 as described in section "Parallel Flash programming mode".

## 9.4 Parallel Flash Programming Mode

### 9.4.1 Flash Configuration in Parallel Flash Programming Mode

Parallel Flash Programming Mode (MD[2:0] = 111):

CY91F467Dx

FA[21:0]					
003F:FFFFh 003F:0000h	SA23 (64KB)				
003E:FFFFh 003E:0000h	SA22 (64KB)				
003D:FFFFh 003D:0000h	SA21 (64KB)				
003C:FFFFh 003C:0000h	SA20 (64KB)				
003B:FFFFh 003B:0000h	SA19 (64KB)				
003A:FFFFh 003A:0000h	SA18 (64KB)				
0039:FFFFh 0039:0000h	SA17 (64KB)				
0038:FFFFh 0038:0000h	SA16 (64KB)				
0037:FFFFh 0037:0000h	SA15 (64KB)				
0036:FFFFh 0036:0000h	SA14 (64KB)				
0035:FFFFh 0035:0000h	SA13 (64KB)				
0034:FFFFh 0034:0000h	SA12 (64KB)				
0033:FFFFh 0033:0000h	SA11 (64KB)				
0032:FFFFh 0032:0000h	SA10 (64KB)				
0031:FFFFh 0031:0000h	SA9 (64KB)				
0030:FFFFh 0030:0000h	SA8 (64KB)				
002F:FFFFh 002F:E000h	SA7 (8KB)				
002F:DFFFh 002F:C000h	SA6 (8KB)				
002F:BFFFh 002F:A000h	SA5 (8KB)				
002F:9FFFh 002F:8000h	SA4 (8KB)				
002F:7FFFh 002F:6000h	SA3 (8KB)				
002F:5FFFh 002F:4000h	SA2 (8KB)				
002F:3FFFh 002F:2000h	SA1 (8KB)				
002F:1FFFh 002F:0000h	SA0 (8KB)				
16bit write mode	<table border="1"> <tr> <th>FA[1:0]=00</th> <th>FA[1:0]=10</th> </tr> <tr> <td>DQ[15:0]</td> <td>DQ[15:0]</td> </tr> </table>	FA[1:0]=00	FA[1:0]=10	DQ[15:0]	DQ[15:0]
FA[1:0]=00	FA[1:0]=10				
DQ[15:0]	DQ[15:0]				

Remark: Always keep FA[0] = 0 and FA[21] = 1

CY91F465DA

FA[20:0]					
001F:FFFFh 001F:0000h	SA19 (64KB)				
001E:FFFFh 001E:0000h	SA18 (64KB)				
001D:FFFFh 001D:0000h	SA17 (64KB)				
001C:FFFFh 001C:0000h	SA16 (64KB)				
001B:FFFFh 001B:0000h	SA15 (64KB)				
001A:FFFFh 001A:0000h	SA14 (64KB)				
0019:FFFFh 0019:0000h	SA13 (64KB)				
0018:FFFFh 0018:0000h	SA12 (64KB)				
	SA11 (64KB)				
	SA10 (64KB)				
	SA9 (64KB)				
	SA8 (64KB)				
0017:FFFFh 0017:E000h	SA7 (8KB)				
0017:DFFFh 0017:C000h	SA6 (8KB)				
0017:BFFFh 0017:A000h	SA5 (8KB)				
0017:9FFFh 0017:8000h	SA4 (8KB)				
	SA3 (8KB)				
	SA2 (8KB)				
	SA1 (8KB)				
	SA0 (8KB)				
16bit write mode	<table border="1"> <tr> <th>FA[1:0]=00</th> <th>FA[1:0]=10</th> </tr> <tr> <td>DQ[15:0]</td> <td>DQ[15:0]</td> </tr> </table>	FA[1:0]=00	FA[1:0]=10	DQ[15:0]	DQ[15:0]
FA[1:0]=00	FA[1:0]=10				
DQ[15:0]	DQ[15:0]				
Legend	<table border="1"> <tr> <td>Memory available in this area</td> </tr> <tr> <td>Memory not available in this area</td> </tr> </table>	Memory available in this area	Memory not available in this area		
Memory available in this area					
Memory not available in this area					

Remark: Always keep FA[0] = 0 and FA[20] = 1

#### 9.4.2 Pin Connections in Parallel Programming Mode

Resetting after setting the MD[2:0] pins to [111] will halt CPU functioning. At this time, the Flash memory's interface circuit enables direct control of the Flash memory unit from external pins by directly linking some of the signals to General Purpose Ports. Please see table below for signal mapping.

In this mode, the Flash memory appears to the external pins as a stand-alone unit. This mode is generally set when writing/erasing using the parallel Flash programmer. In this mode, all operations of the 8.5 Mbits Flash memory's Auto Algorithms are available.

Correspondence between CYM29LV400TC and Flash Memory Control Signals

CYM29LV400TC External Pins	FR-CPU Mode	CY91F465DA, CY91F467Dx External Pins			Comment
		Flash Memory Mode	Normal Function	Pin Number	
—	INITX	—	INITX	73	
RESET	—	FRSTX	P09_6	60	
—	—	MD_2	MD_2	70	Set to '1'
—	—	MD_1	MD_1	71	Set to '1'
—	—	MD_0	MD_0	72	Set to '1'
RY/BY	FMCS:RDY bit	RY/BYX	P09_0	56	
BYTE	Internally fixed to 'H'	BYTEX	P09_2	58	
WE	Internal control signal + control via interface circuit	WEX	P13_2	191	
OE		OEX	P13_1	190	
CE		CEX	P13_0	189	
—		ATDIN	P25_7	187	Set to '0'
—		EQIN	P25_6	186	Set to '0'
—		TESTX	P09_3	59	Set to '1'
—		RDYI	P09_1	57	Set to '0'
A-1		Internal address bus	FA0	P25_5	185
A0 to A3	FA1 to FA4		P27_0 to P27_3	158 to 161	
A4 to A7	FA5 to FA8		P27_4 to P27_7	164 to 167	
A8 to A11	FA9 to FA12		P26_0 to P26_3	168 to 171	
A12 to A15	FA13 to FA16		P26_4 to P26_7	174 to 177	
A16 to A19	FA17 to FA20		P25_0 to P25_3	178 to 181	
—	FA21		P25_4	184	Not needed on CY91F465DA; Set to '1' on CY91F467Dx
DQ0 to DQ7	Internal data bus	DQ0 to DQ7	P03_0 to P03_7	192 to 199	
DQ8 to DQ15		DQ8 to DQ15	P02_0 to P02_7	200 to 207	

### 9.5 Poweron Sequence in Parallel Programming Mode

The flash memory can be accessed in programming mode after a certain wait time, which is needed for Security Vector fetch:

- Minimum wait time after VDD5/VDD5R power on: 2.76 ms
- Minimum wait time after INITX rising: 1.0 ms

### 9.6 Flash Security

#### 9.6.1 Vector Addresses

Two Flash Security Vectors (FSV1, FSV2) are located parallel to the Boot Security Vectors (BSV1, BSV2) controlling the protection functions of the Flash Security Module:

FSV1: 0x14:8000      BSV1: 0x14:8004  
 FSV2: 0x14:8008      BSV2: 0x14:800C

#### 9.6.2 Security Vector FSV1

The setting of the Flash Security Vector FSV1 is responsible for the read and write protection modes and the individual write protection of the 8 Kbytes sectors.

#### FSV1 (bit31 to bit16)

The setting of the Flash Security Vector FSV1 bits [31:16] is responsible for the read and write protection modes.

Explanation of the bits in the Flash Security Vector FSV1 [31:16]

FSV1[31:19]	FSV1[18] Write Protection Level	FSV1[17] Write Protection	FSV1[16] Read Protection	Flash Security Mode
set all to "0"	set to "0"	set to "0"	set to "1"	Read Protection (all device modes, except INTVEC mode MD[2:0] = "000")
set all to "0"	set to "0"	set to "1"	set to "0"	Write Protection (all device modes, without exception)
set all to "0"	set to "0"	set to "1"	set to "1"	Read Protection (all device modes, except INTVEC mode MD[2:0] = "000") and Write Protection (all device modes)
set all to "0"	set to "1"	set to "0"	set to "1"	Read Protection (all device modes, except INTVEC mode MD[2:0] = "000")
set all to "0"	set to "1"	set to "1"	set to "0"	Write Protection (all device modes, except INTVEC mode MD[2:0] = "000")
set all to "0"	set to "1"	set to "1"	set to "1"	Read Protection (all device modes, except INTVEC mode MD[2:0] = "000") and Write Protection (all device modes except INTVEC mode MD[2:0] = "000")

FSV1 (bit15 to bit0)

The setting of the Flash Security Vector FSV1 bits [15:0] is responsible for the individual write protection of the 8 Kbytes sectors. It is only evaluated if write protection bit FSV1[17] is set.

Explanation of the bits in the Flash Security Vector FSV1 [15:0]

FSV1 bit	Sector	Enable Write Protection	Disable Write Protection	Comment
FSV1[0]	SA0 (CY91F467Dx)	set to "0"	set to "1"	
FSV1[1]	SA1 (CY91F467Dx)	set to "0"	set to "1"	
FSV1[2]	SA2 (CY91F467Dx)	set to "0"	set to "1"	
FSV1[3]	SA3 (CY91F467Dx)	set to "0"	set to "1"	
FSV1[4]	SA4	set to "0"	—	Write protection is mandatory!
FSV1[5]	SA5	set to "0"	set to "1"	
FSV1[6]	SA6	set to "0"	set to "1"	
FSV1[7]	SA7	set to "0"	set to "1"	
FSV1[8]	—	set to "0"	set to "1"	not available
FSV1[9]	—	set to "0"	set to "1"	not available
FSV1[10]	—	set to "0"	set to "1"	not available
FSV1[11]	—	set to "0"	set to "1"	not available
FSV1[12]	—	set to "0"	set to "1"	not available
FSV1[13]	—	set to "0"	set to "1"	not available
FSV1[14]	—	set to "0"	set to "1"	not available
FSV1[15]	—	set to "0"	set to "1"	not available

**Note :** It is mandatory to always set the sector where the Flash Security Vectors FSV1 and FSV2 are located to write protected (here sector SA4). Otherwise it is possible to overwrite the Security Vector to a setting where it is possible to either read out the Flash content or manipulate data by writing.

See section "Flash access in CPU mode" for an overview about the sector organisation of the Flash Memory.

### 9.6.3 Security Vector FSV2

The setting of the Flash Security Vector FSV2 bits [31:0] is responsible for the individual write protection of the 64 Kbytes sectors. It is only evaluated if write protection bit FSV1 [17] is set.

Explanation of the bits in the Flash Security Vector FSV2[31:0]

FSV2 bit	Sector	Enable Write Protection	Disable Write Protection	Comment
FSV2[0]	SA8 (CY91F467Dx)	set to "0"	set to "1"	
FSV2[1]	SA9 (CY91F467Dx)	set to "0"	set to "1"	
FSV2[2]	SA10 (CY91F467Dx)	set to "0"	set to "1"	
FSV2[3]	SA11 (CY91F467Dx)	set to "0"	set to "1"	
FSV2[4]	SA12	set to "0"	set to "1"	
FSV2[5]	SA13	set to "0"	set to "1"	
FSV2[6]	SA14	set to "0"	set to "1"	
FSV2[7]	SA15	set to "0"	set to "1"	
FSV2[8]	SA16	set to "0"	set to "1"	
FSV2[9]	SA17	set to "0"	set to "1"	
FSV2[10]	SA18	set to "0"	set to "1"	
FSV2[11]	SA19	set to "0"	set to "1"	
FSV2[12]	SA20 (CY91F467Dx)	set to "0"	set to "1"	
FSV2[13]	SA21 (CY91F467Dx)	set to "0"	set to "1"	
FSV2[14]	SA22 (CY91F467Dx)	set to "0"	set to "1"	
FSV2[15]	SA23 (CY91F467Dx)	set to "0"	set to "1"	
FSV2[31:16]	—	set to "0"	set to "1"	not available

Note : See section "Flash access in CPU mode" for an overview about the sector organisation of the Flash Memory.



## 10. Memory Space

The FR family has 4 Gbytes of logical address space ( $2^{32}$  addresses) available to the CPU by linear access.

### Direct Addressing Area

The following address space area is used for I/O.

This area is called direct addressing area, and the address of an operand can be specified directly in an instruction.

The size of directly addressable area depends on the length of the data being accessed as shown below.

Byte data access : 000<sub>H</sub> to 0FF<sub>H</sub>

Half word access : 000<sub>H</sub> to 1FF<sub>H</sub>

Word data access : 000<sub>H</sub> to 3FF<sub>H</sub>

## 11. Memory Maps

### 11.1 CY91F465DA, CY91F467Dx

00000000 <sub>H</sub>	I/O (direct addressing area)
00000400 <sub>H</sub>	I/O
00001000 <sub>H</sub>	DMA
00002000 <sub>H</sub>	
00004000 <sub>H</sub>	Flash-Cache (8 KBytes)
00006000 <sub>H</sub>	
00007000 <sub>H</sub>	Flash memory control
00008000 <sub>H</sub>	
0000B000 <sub>H</sub>	Boot ROM (4 Kbytes)
0000C000 <sub>H</sub>	CAN
0000D000 <sub>H</sub>	
00028000 <sub>H</sub>	D-RAM (0 wait, 32 Kbytes)
00030000 <sub>H</sub>	ID-RAM (32 Kbytes)
00038000 <sub>H</sub>	
00040000 <sub>H</sub>	Flash memory (1088 Kbytes)
00150000 <sub>H</sub>	
00180000 <sub>H</sub>	External bus area
00500000 <sub>H</sub>	External data bus
FFFFFFFF <sub>H</sub>	

Note:

Access prohibited areas

00000000 <sub>H</sub>	I/O (direct addressing area)
00000400 <sub>H</sub>	I/O
00001000 <sub>H</sub>	DMA
00002000 <sub>H</sub>	
00004000 <sub>H</sub>	Flash-Cache (8 KBytes)
00006000 <sub>H</sub>	
00007000 <sub>H</sub>	Flash memory control
00008000 <sub>H</sub>	
0000B000 <sub>H</sub>	Boot ROM (4 Kbytes)
0000C000 <sub>H</sub>	CAN
0000D000 <sub>H</sub>	
00028000 <sub>H</sub>	D-RAM (0 wait, 32 Kbytes)
00030000 <sub>H</sub>	ID-RAM (16 Kbytes)
00034000 <sub>H</sub>	
00040000 <sub>H</sub>	External bus area
00080000 <sub>H</sub>	Flash memory (512 Kbytes)
00100000 <sub>H</sub>	External bus area
00148000 <sub>H</sub>	Flash memory (32 Kbytes)
00150000 <sub>H</sub>	
00180000 <sub>H</sub>	External bus area
00500000 <sub>H</sub>	External data bus
FFFFFFFF <sub>H</sub>	

Note:

Access prohibited areas

## 12. I/O Map

### 12.1 CY91F465DA, CY91F467Dx

Address	Register				Block
	+ 0	+ 1	+ 2	+ 3	
000000 <sub>H</sub>	PDR0 [R/W] XXXXXXXX	PDR1 [R/W] XXXXXXXX	PDR2 [R/W] XXXXXXXX	PDR3 [R/W] XXXXXXXX	T-unit port data register

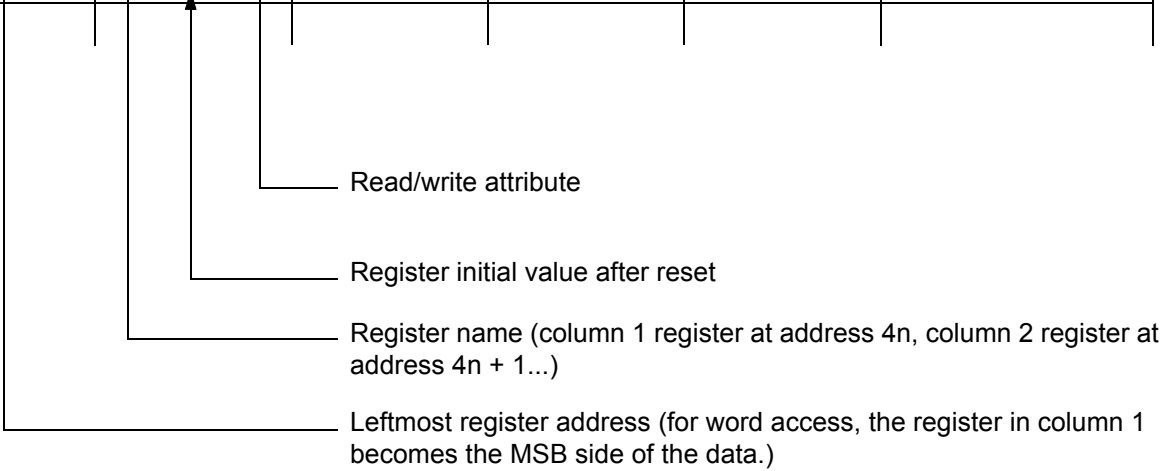

Read/write attribute

Register initial value after reset

Register name (column 1 register at address 4n, column 2 register at address 4n + 1...)

Leftmost register address (for word access, the register in column 1 becomes the MSB side of the data.)

Note : Initial values of register bits are represented as follows:

- “ 1 ” : Initial value “ 1 ”
- “ 0 ” : Initial value “ 0 ”
- “ X ” : Initial value “ undefined ”
- “ - ” : No physical register at this location

Access is barred with an undefined data access attribute.

Address	Register				Block
	+ 0	+ 1	+ 2	+ 3	
00000 <sub>H</sub>	PDR00 [R/W] XXXXXXXX	PDR01 [R/W] XXXXXXXX	PDR02 [R/W] XXXXXXXX	PDR03 [R/W] XXXXXXXX	R-bus Port Data Register
00004 <sub>H</sub>	PDR04 [R/W] -----XX	PDR05 [R/W] XXXXXXXX	PDR06 [R/W] XXXXXXXX	PDR07 [R/W] XXXXXXXX	
00008 <sub>H</sub>	PDR08 [R/W] XXXXXXXX	PDR09 [R/W] XX - - XXXX	PDR10 [R/W] - XXXXXX -	Reserved	
0000C <sub>H</sub>	Reserved	PDR13 [R/W] -----XXX	PDR14 [R/W] XXXXXXXX	PDR15 [R/W] ---- XXXX	
00010 <sub>H</sub>	PDR16 [R/W] XXXXXXXX	PDR17 [R/W] XXXX ----	PDR18 [R/W] - XXX - XXX	PDR19 [R/W] - XXX - XXX	
00014 <sub>H</sub>	PDR20 [R/W] -----XXX	Reserved	PDR22 [R/W] -- XX - X - X	PDR23 [R/W] -- XXXXXX	
00018 <sub>H</sub>	PDR24 [R/W] XXXXXXXX	PDR25 [R/W] XXXXXXXX	PDR26 [R/W] XXXXXXXX	PDR27 [R/W] XXXXXXXX	
0001C <sub>H</sub>	Reserved	PDR29 [R/W] XXXXXXXX	Reserved		
00020 <sub>H</sub> to 0002C <sub>H</sub>	Reserved				Reserved
00030 <sub>H</sub>	EIRR0 [R/W] XXXXXXXX	ENIR0 [R/W] 00000000	ELVR0 [R/W] 00000000 00000000		External interrupt (INT 0 to INT 7)
00034 <sub>H</sub>	EIRR1 [R/W] XXXXXXXX	ENIR1 [R/W] 00000000	ELVR1 [R/W] 00000000 00000000		External interrupt (INT 8 to INT 10, INT 12 to INT 14)
00038 <sub>H</sub>	DICR [R/W] ----- 0	HRCL [R/W] 0 - - 11111	Reserved		Delay Interrupt
0003C <sub>H</sub> to 0004C <sub>H</sub>	Reserved				Reserved
00050 <sub>H</sub>	SCR02 [R/W, W] 00000000	SMR02 [R/W, W] 00000000	SSR02 [R/W, R] 00001000	RDR02/TDR02 [R/W] 00000000	LIN-USART 2
00054 <sub>H</sub>	ESCR02 [R/W] 0000X00	ECCR02 [R/W, R, W] -0000XX	Reserved		
00058 <sub>H</sub> , 0005C <sub>H</sub>	Reserved				Reserved

*(Continued)*

(Continued)

Address	Register				Block
	+ 0	+ 1	+ 2	+ 3	
000060 <sub>H</sub>	SCR04 [R/W, W] 00000000	SMR04 [R/W, W] 00000000	SSR04 [R/W, R] 00001000	RDR04/TDR04 [R/W] 00000000	LIN-USART 4 with FIFO
000064 <sub>H</sub>	ESCR04 [R/W] 00000X00	ECCR04 [R/W, R, W] -00000XX	FSR04 [R] --- 00000	FCR04 [R/W] 0001 - 000	
000068 <sub>H</sub>	SCR05 [R/W, W] 00000000	SMR05 [R/W, W] 00000000	SSR05 [R/W, R] 00001000	RDR05/TDR05 [R/W] 00000000	LIN-USART 5 with FIFO
00006C <sub>H</sub>	ESCR05 [R/W] 00000X00	ECCR05 [R/W, R, W] -00000XX	FSR05 [R] --- 00000	FCR05 [R/W] 0001 - 000	
000070 <sub>H</sub>	SCR06 [R/W, W] 00000000	SMR06 [R/W, W] 00000000	SSR06 [R/W, R] 00001000	RDR06/TDR06 [R/W] 00000000	LIN-USART 6 with FIFO
000074 <sub>H</sub>	ESCR06 [R/W] 00000X00	ECCR06 [R/W, R, W] -00000XX	FSR06 [R] --- 00000	FCR06 [R/W] 0001 - 000	
000078 <sub>H</sub>	SCR07 [R/W, W] 00000000	SMR07 [R/W, W] 00000000	SSR07 [R/W, R] 00001000	RDR07/TDR07 [R/W] 00000000	LIN-USART 7 with FIFO
00007C <sub>H</sub>	ESCR07 [R/W] 00000X00	ECCR07 [R/W, R, W] -00000XX	FSR07 [R] --- 00000	FCR07 [R/W] 0001 - 000	
000080 <sub>H</sub>	Reserved				Reserved
000084 <sub>H</sub>	BGR102 [R/W] 00000000	BGR002 [R/W] 00000000	Reserved		Baud rate Generator LIN-USART 2,4 to 7
000088 <sub>H</sub>	BGR104 [R/W] 00000000	BGR004 [R/W] 00000000	BGR105 [R/W] 00000000	BGR005 [R/W] 00000000	
00008C <sub>H</sub>	BGR106 [R/W] 00000000	BGR006 [R/W] 00000000	BGR107 [R/W] 00000000	BGR007 [R/W] 00000000	
000090 <sub>H</sub>	PWC20 [R/W] ----- XX XXXXXXXX		PWC10 [R/W] ----- XX XXXXXXXX		Stepper Motor 0
000094 <sub>H</sub>	Reserved		PWS20 [R/W] -0000000	PWS10 [R/W] - -000000	
000098 <sub>H</sub>	PWC21 [R/W] ----- XX XXXXXXXX		PWC11 [R/W] ----- XX XXXXXXXX		Stepper Motor 1
00009C <sub>H</sub>	Reserved		PWS21 [R/W] -0000000	PWS11 [R/W] - -000000	

(Continued)

(Continued)

Address	Register				Block
	+ 0	+ 1	+ 2	+ 3	
0000A0 <sub>H</sub>	PWC22 [R/W] -----XX XXXXXXXX		PWC12 [R/W] -----XX XXXXXXXX		Stepper Motor 2
0000A4 <sub>H</sub>	Reserved		PWS22 [R/W] -0000000	PWS12 [R/W] --000000	
0000A8 <sub>H</sub>	PWC23 [R/W] -----XX XXXXXXXX		PWC13 [R/W] -----XX XXXXXXXX		Stepper Motor 3
0000AC <sub>H</sub>	Reserved		PWS23 [R/W] -0000000	PWS13 [R/W] --000000	
0000B0 <sub>H</sub>	PWC24 [R/W] -----XX XXXXXXXX		PWC14 [R/W] -----XX XXXXXXXX		Stepper Motor 4
0000B4 <sub>H</sub>	Reserved		PWS24 [R/W] -0000000	PWS14 [R/W] --000000	
0000B8 <sub>H</sub>	PWC25 [R/W] -----XX XXXXXXXX		PWC15 [R/W] -----XX XXXXXXXX		Stepper Motor 5
0000BC <sub>H</sub>	Reserved		PWS25 [R/W] -0000000	PWS15 [R/W] --000000	
0000C0 <sub>H</sub>	Reserved	PWC0 [R/W] -00000--	Reserved	PWC1 [R/W] -00000--	Stepper Motor Control 0 to 5
0000C4 <sub>H</sub>	Reserved	PWC2 [R/W] -00000--	Reserved	PWC3 [R/W] -00000--	
0000C8 <sub>H</sub>	Reserved	PWC4 [R/W] -00000--	Reserved	PWC5 [R/W] -00000--	
0000CC <sub>H</sub>	Reserved				Reserved
0000D0 <sub>H</sub>	IBCR0 [R/W] 00000000	IBSR0 [R] 00000000	ITBAH0 [R/W] -----00	ITBAL0 [R/W] 00000000	I <sup>2</sup> C 0
0000D4 <sub>H</sub>	ITMKH0 [R/W] 00----11	ITMKL0 [R/W] 11111111	ISMK0 [R/W] 01111111	ISBA0 [R/W] -0000000	
0000D8 <sub>H</sub>	Reserved	IDAR0 [R/W] 00000000	ICCR0 [R/W] 00011111	Reserved	
0000DC <sub>H</sub> to 000100 <sub>H</sub>	Reserved				Reserved
000104 <sub>H</sub>	GCN11 [R/W] 00110010 00010000		Reserved	GCN21 [R/W] ----0000	PPG Control 4 to 7
000108 <sub>H</sub>	GCN12 [R/W] 00110010 00010000		Reserved	GCN22 [R/W] ----0000	PPG Control 8 to 11
000110 <sub>H</sub> to 00012C <sub>H</sub>	Reserved				Reserved

(Continued)

*(Continued)*

Address	Register				Block
	+ 0	+ 1	+ 2	+ 3	
000130 <sub>H</sub>	PTMR04 [R] 11111111 11111111		PCSR04 [W] XXXXXXXX XXXXXXXX		PPG 4
000134 <sub>H</sub>	PDUT04 [W] XXXXXXXXXX XXXXXXXX		PCNH04 [R/W] 0000000 -	PCNL04 [R/W] 000000 - 0	
000138 <sub>H</sub>	PTMR05 [R] 11111111 11111111		PCSR05 [W] XXXXXXXXXX XXXXXXXX		PPG 5
00013C <sub>H</sub>	PDUT05 [W] XXXXXXXXXX XXXXXXXX		PCNH05 [R/W] 0000000 -	PCNL05 [R/W] 000000 - 0	
000140 <sub>H</sub>	PTMR06 [R] 11111111 11111111		PCSR06 [W] XXXXXXXXXX XXXXXXXX		PPG 6
000144 <sub>H</sub>	PDUT06 [W] XXXXXXXXXX XXXXXXXX		PCNH06 [R/W] 0000000 -	PCNL06 [R/W] 000000 - 0	
000148 <sub>H</sub>	PTMR07 [R] 11111111 11111111		PCSR07 [W] XXXXXXXXXX XXXXXXXX		PPG 7
00014C <sub>H</sub>	PDUT07 [W] XXXXXXXXXX XXXXXXXX		PCNH07 [R/W] 0000000 -	PCNL07 [R/W] 000000 - 0	
000150 <sub>H</sub>	PTMR08 [R] 11111111 11111111		PCSR08 [W] XXXXXXXXXX XXXXXXXX		PPG 8
000154 <sub>H</sub>	PDUT08 [W] XXXXXXXXXX XXXXXXXX		PCNH08 [R/W] 0000000 -	PCNL08 [R/W] 000000 - 0	
000158 <sub>H</sub>	PTMR09 [R] 11111111 11111111		PCSR09 [W] XXXXXXXXXX XXXXXXXX		PPG 9
00015C <sub>H</sub>	PDUT09 [W] XXXXXXXXXX XXXXXXXX		PCNH09 [R/W] 0000000 -	PCNL09 [R/W] 000000 - 0	
000160 <sub>H</sub>	PTMR10 [R] 11111111 11111111		PCSR10 [W] XXXXXXXXXX XXXXXXXX		PPG 10
000164 <sub>H</sub>	PDUT10 [W] XXXXXXXXXX XXXXXXXX		PCNH10 [R/W] 0000000 -	PCNL10 [R/W] 000000 - 0	
000168 <sub>H</sub>	PTMR11 [R] 11111111 11111111		PCSR11 [W] XXXXXXXXXX XXXXXXXX		PPG 11
00016C <sub>H</sub>	PDUT11 [W] XXXXXXXXXX XXXXXXXX		PCNH11 [R/W] 0000000 -	PCNL11 [R/W] 000000 - 0	
000170 <sub>H</sub>	P0TMCSRH [R/W] - 0 - 000 - 0	P0TMCSRL [R/W] - - - 00000	P1TMCSRH [R/W] - 0 - 000 - 0	P1TMCSRL [R/W] - - - 00000	PFM
000174 <sub>H</sub>	P0TMRLR [W] XXXXXXXXXX XXXXXXXX		P0TMR [R] XXXXXXXXXX XXXXXXXX		
000178 <sub>H</sub>	P1TMRLR [W] XXXXXXXXXX XXXXXXXX		P1TMR [R] XXXXXXXXXX XXXXXXXX		
00017C <sub>H</sub>	Reserved				Reserved

*(Continued)*

*(Continued)*

Address	Register				Block
	+ 0	+ 1	+ 2	+ 3	
000180 <sub>H</sub>	Reserved	ICS01 [R/W] 00000000	Reserved	ICS23 [R/W] 00000000	Input Capture 0 to 3
000184 <sub>H</sub>	IPCP0 [R] XXXXXXXX XXXXXXXX		IPCP1 [R] XXXXXXXX XXXXXXXX		
000188 <sub>H</sub>	IPCP2 [R] XXXXXXXX XXXXXXXX		IPCP3 [R] XXXXXXXX XXXXXXXX		
00018C <sub>H</sub>	OCS01 [R/W] --- 0 -- 00 0000 -- 00		OCS23 [R/W] --- 0 -- 00 0000 -- 00		Output Compare 0 to 3
000190 <sub>H</sub>	OCCP0 [R/W] XXXXXXXX XXXXXXXX		OCCP1 [R/W] XXXXXXXX XXXXXXXX		
000194 <sub>H</sub>	OCCP2 [R/W] XXXXXXXX XXXXXXXX		OCCP3 [R/W] XXXXXXXX XXXXXXXX		
000198 <sub>H</sub>	SGCRH [R/W] 0000 -- 00	SGCRL [R/W] -- 0 -- 000	SGFR [R/W, R] XXXXXXXX XXXXXXXX		Sound Generator
00019C <sub>H</sub>	SGAR [R/W] 00000000	Reserved	SGTR [R/W] XXXXXXXX	SGDR [R/W] XXXXXXXX	
0001A0 <sub>H</sub>	ADERH [R/W] 00000000 00000000		ADERL [R/W] 00000000 00000000		A/D Converter
0001A4	ADCS1 [R/W] 00000000	ADCS0 [R/W] 00000000	ADCR1 [R] 000000XX	ADCR0 [R] XXXXXXXX	
0001A8 <sub>H</sub>	ADCT1 [R/W] 00010000	ADCT0 [R/W] 00101100	ADSCH [R/W] --- 00000	ADECH [R/W] --- 00000	
0001AC <sub>H</sub>	Reserved	ACSR0 [R/W] - 11XXXX00	Reserved		Alarm Comparator 0
0001B0 <sub>H</sub>	TMRLR0 [W] XXXXXXXX XXXXXXXX		TMR0 [R] XXXXXXXX XXXXXXXX		Reload Timer 0
0001B4 <sub>H</sub>	Reserved		TMCSRH0 [R/W] --- 00000	TMCSRL0 [R/W] 0 - 000000	
0001B8 <sub>H</sub>	TMRLR1 [W] XXXXXXXX XXXXXXXX		TMR1 [R] XXXXXXXX XXXXXXXX		Reload Timer 1
0001BC <sub>H</sub>	Reserved		TMCSRH1 [R/W] --- 00000	TMCSRL1 [R/W] 0 - 000000	
0001C0 <sub>H</sub>	TMRLR2 [W] XXXXXXXX XXXXXXXX		TMR2 [R] XXXXXXXX XXXXXXXX		Reload Timer 2 (PPG 4, PPG 5)
0001C4 <sub>H</sub>	Reserved		TMCSRH2 [R/W] --- 00000	TMCSRL2 [R/W] 0 - 000000	

*(Continued)*



(Continued)

Address	Register				Block
	+ 0	+ 1	+ 2	+ 3	
0001C8 <sub>H</sub>	TMRLR3 [W] XXXXXXXX XXXXXXXX		TMR3 [R] XXXXXXXX XXXXXXXX		Reload Timer 3  (PPG 6, PPG 7)
0001CC <sub>H</sub>	Reserved		TMCSRH3 [R/W] --- 00000	TMCSRL3 [R/W] 0 - 000000	
0001D0 <sub>H</sub>	TMRLR4 [W] XXXXXXXX XXXXXXXX		TMR4 [R] XXXXXXXX XXXXXXXX		Reload Timer 4  (PPG 8, PPG 9)
0001D4 <sub>H</sub>	Reserved		TMCSRH4 [R/W] --- 00000	TMCSRL4 [R/W] 0 - 000000	
0001D8 <sub>H</sub>	TMRLR5 [W] XXXXXXXX XXXXXXXX		TMR5 [R] XXXXXXXX XXXXXXXX		Reload Timer 5  (PPG 10, PPG 11)
0001DC <sub>H</sub>	Reserved		TMCSRH5 [R/W] --- 00000	TMCSRL5 [R/W] 0 - 000000	
0001E0 <sub>H</sub>	TMRLR6 [W] XXXXXXXX XXXXXXXX		TMR6 [R] XXXXXXXX XXXXXXXX		Reload Timer 6  (PPG 12, PPG 13)
0001E4 <sub>H</sub>	Reserved		TMCSRH6 [R/W] --- 00000	TMCSRL6 [R/W] 0 - 000000	
0001E8 <sub>H</sub>	TMRLR7 [W] XXXXXXXX XXXXXXXX		TMR7 [R] XXXXXXXX XXXXXXXX		Reload Timer 7  (PPG 14, PPG 15) (A/D Converter)
0001EC <sub>H</sub>	Reserved		TMCSRH7 [R/W] --- 00000	TMCSRL7 [R/W] 0 - 000000	
0001F0 <sub>H</sub>	TCDT0 [R/W] XXXXXXXX XXXXXXXX		Reserved	TCCS0 [R/W] 00000000	Free Running Timer 0  (ICU 0, ICU 1)
0001F4 <sub>H</sub>	TCDT1 [R/W] XXXXXXXX XXXXXXXX		Reserved	TCCS1 [R/W] 00000000	Free Running Timer 1  (ICU 2, ICU 3)
0001F8 <sub>H</sub>	TCDT2 [R/W] XXXXXXXX XXXXXXXX		Reserved	TCCS2 [R/W] 00000000	Free Running Timer 2  (OCU 0, OCU 1)
0001FC <sub>H</sub>	TCDT3 [R/W] XXXXXXXX XXXXXXXX		Reserved	TCCS3 [R/W] 00000000	Free Running Timer 3  (OCU 2, OCU 3)

(Continued)

(Continued)

Address	Register				Block
	+ 0	+ 1	+ 2	+ 3	
000200 <sub>H</sub>	DMACA0 [R/W] 00000000 0000XXXX XXXXXXXX XXXXXXXX				DMAC
000204 <sub>H</sub>	DMACB0 [R/W] 00000000 00000000 XXXXXXXX XXXXXXXX				
000208 <sub>H</sub>	DMACA1 [R/W] 00000000 0000XXXX XXXXXXXX XXXXXXXX				
00020C <sub>H</sub>	DMACB1 [R/W] 00000000 00000000 XXXXXXXX XXXXXXXX				
000210 <sub>H</sub>	DMACA2 [R/W] 00000000 0000XXXX XXXXXXXX XXXXXXXX				
000214 <sub>H</sub>	DMACB2 [R/W] 00000000 00000000 XXXXXXXX XXXXXXXX				
000218 <sub>H</sub>	DMACA3 [R/W] 00000000 0000XXXX XXXXXXXX XXXXXXXX				
00021C <sub>H</sub>	DMACB3 [R/W] 00000000 00000000 XXXXXXXX XXXXXXXX				
000220 <sub>H</sub>	DMACA4 [R/W] 00000000 0000XXXX XXXXXXXX XXXXXXXX				
000224 <sub>H</sub>	DMACB4 [R/W] 00000000 00000000 XXXXXXXX XXXXXXXX				
000228 <sub>H</sub> to 00023C <sub>H</sub>	Reserved				
000240 <sub>H</sub>	DMACR [R/W] 00 - - 0000	Reserved			
000244 <sub>H</sub> to 0002CC <sub>H</sub>	Reserved				Reserved
0002D0 <sub>H</sub>	Reserved	ICS045 [R/W] 00000000	Reserved	ICS67 [R/W] 00000000	Input Capture 4 to 7
0002D4 <sub>H</sub>	IPCP4 [R] XXXXXXXX XXXXXXXX		IPCP5 [R] XXXXXXXX XXXXXXXX		
0002D8 <sub>H</sub>	IPCP6 [R] XXXXXXXX XXXXXXXX		IPCP7 [R] XXXXXXXX XXXXXXXX		
0002DC <sub>H</sub> to 0002EC <sub>H</sub>	Reserved				Reserved
0002F0 <sub>H</sub>	TCDT4 [R/W] XXXXXXXX XXXXXXXX		Reserved	TCCS4 [R/W] 00000000	Free Running Timer 4  (ICU 4, ICU 5)

(Continued)

*(Continued)*

Address	Register				Block
	+ 0	+ 1	+ 2	+ 3	
0002F4 <sub>H</sub>	TCDT5 [R/W] XXXXXXXX XXXXXXXX		Reserved	TCCS5 [R/W] 00000000	Free Running Timer 5  (ICU 6, ICU 7)
0002F8 <sub>H</sub>	TCDT6 [R/W] XXXXXXXX XXXXXXXX		Reserved	TCCS6 [R/W] 00000000	Free Running Timer 6
0002FC <sub>H</sub>	TCDT7 [R/W] XXXXXXXX XXXXXXXX		Reserved	TCCS7 [R/W] 00000000	Free Running Timer 7
000300 <sub>H</sub>	Reserved	UDRC0 [W] 00000000	Reserved	UDCR0 [R] 00000000	Up/Down Counter 0
000304 <sub>H</sub>	UDCCH0 [R/W] 00000000	UDCCL0 [R/W] 00001000	Reserved	UDCS0 [R/W] 00000000	
000308 <sub>H</sub> , 00030C <sub>H</sub>	Reserved				Reserved
000310 <sub>H</sub>	UDRC3 [W] 00000000	UDRC2 [W] 00000000	UDCR3 [R] 00000000	UDCR2 [R] 00000000	Up/Down Counter 2 to 3
000314 <sub>H</sub>	UDCCH2 [R/W] 00000000	UDCCL2 [R/W] 00001000	Reserved	UDCS2 [R/W] 00000000	
000318 <sub>H</sub>	UDCCH3 [R/W] 00000000	UDCCL3 [R/W] 00001000	Reserved	UDCS3 [R/W] 00000000	
00031C <sub>H</sub>	Reserved				Reserved
000320 <sub>H</sub>	GCN13 [R/W] 00110010 00010000		Reserved	GCN23 [R/W] ---- 0000	PPG Control 12 to 15
000324 <sub>H</sub> to 00032C <sub>H</sub>	Reserved				Reserved
000330 <sub>H</sub>	PTMR12 [R] 11111111 11111111		PCSR12 [W] XXXXXXXX XXXXXXXX		PPG 12
000334 <sub>H</sub>	PDUT12 [W] XXXXXXXX XXXXXXXX		PCNH12 [R/W] 0000000 -	PCNL12 [R/W] 000000 - 0	
000338 <sub>H</sub>	PTMR13 [R] 11111111 11111111		PCSR13 [W] XXXXXXXX XXXXXXXX		PPG 13
00033C <sub>H</sub>	PDUT13 [W] XXXXXXXX XXXXXXXX		PCNH13 [R/W] 0000000 -	PCNL13 [R/W] 000000 - 0	
000340 <sub>H</sub>	PTMR14 [R] 11111111 11111111		PCSR14 [W] XXXXXXXX XXXXXXXX		PPG 14
000344 <sub>H</sub>	PDUT14 [W] XXXXXXXX XXXXXXXX		PCNH14 [R/W] 0000000 -	PCNL14 [R/W] 000000 - 0	

*(Continued)*

(Continued)

Address	Register				Block
	+ 0	+ 1	+ 2	+ 3	
000348 <sub>H</sub>	PTMR15 [R] 11111111 11111111		PCSR15 [W] XXXXXXXX XXXXXXXX		PPG 15
00034C <sub>H</sub>	PDUT15 [W] XXXXXXXX XXXXXXXX		PCNH15 [R/W] 0000000 -	PCNL15 [R/W] 000000 - 0	
000350 <sub>H</sub> to 000364 <sub>H</sub>	Reserved				Reserved
000368 <sub>H</sub>	IBCR2 [R/W] 00000000	IBSR2 [R] 00000000	ITBAH2 [R/W] ----- 00	ITBAL2 [R/W] 00000000	I <sup>2</sup> C 2
00036C <sub>H</sub>	ITMKH2 [R/W] 00 ---- 11	ITMKL2 [R/W] 11111111	ISMK2 [R/W] 01111111	ISBA2 [R/W] - 0000000	
000370 <sub>H</sub>	Reserved	IDAR2 [R/W] 00000000	ICCR2 [R/W] 00011111	Reserved	
000374 <sub>H</sub>	IBCR3 [R/W] 00000000	IBSR3 [R] 00000000	ITBAH3 [R/W] ----- 00	ITBAL3 [R/W] 00000000	I <sup>2</sup> C 3
000378 <sub>H</sub>	ITMKH3 [R/W] 00 ---- 11	ITMKL3 [R/W] 11111111	ISMK3 [R/W] 01111111	ISBA3 [R/W] - 0000000	
00037C <sub>H</sub>	Reserved	IDAR3 [R/W] 00000000	ICCR3 [R/W] 00011111	Reserved	
000380 <sub>H</sub> to 00038C <sub>H</sub>	Reserved				Reserved
000390 <sub>H</sub>	ROMS [R] 11111111 00000000 (CY91F467Dx) 11111111 01000011 (CY91F465DA)		Reserved		ROM Select Register
000394 <sub>H</sub> to 0003EC <sub>H</sub>	Reserved				Reserved
0003F0 <sub>H</sub>	BSD0 [W] XXXXXXXX XXXXXXXX XXXXXXXX XXXXXXXX				Bit Search Module
0003F4 <sub>H</sub>	BSD1 [R/W] XXXXXXXX XXXXXXXX XXXXXXXX XXXXXXXX				
0003F8 <sub>H</sub>	BSDC [W] XXXXXXXX XXXXXXXX XXXXXXXX XXXXXXXX				
0003FC <sub>H</sub>	BSRR [R] XXXXXXXX XXXXXXXX XXXXXXXX XXXXXXXX				
000400 <sub>H</sub> to 00043C <sub>H</sub>	Reserved				Reserved

(Continued)

(Continued)

Address	Register				Block
	+ 0	+ 1	+ 2	+ 3	
000440 <sub>H</sub>	ICR00 [R/W] ---11111	ICR01 [R/W] ---11111	ICR02 [R/W] ---11111	ICR03 [R/W] ---11111	Interrupt Controller
000444 <sub>H</sub>	ICR04 [R/W] ---11111	ICR05 [R/W] ---11111	ICR06 [R/W] ---11111	ICR07 [R/W] ---11111	
000448 <sub>H</sub>	ICR08 [R/W] ---11111	ICR09 [R/W] ---11111	ICR10 [R/W] ---11111	ICR11 [R/W] ---11111	
00044C <sub>H</sub>	ICR12 [R/W] ---11111	ICR13 [R/W] ---11111	ICR14 [R/W] ---11111	ICR15 [R/W] ---11111	
000450 <sub>H</sub>	ICR16 [R/W] ---11111	ICR17 [R/W] ---11111	ICR18 [R/W] ---11111	ICR19 [R/W] ---11111	
000454 <sub>H</sub>	ICR20 [R/W] ---11111	ICR21 [R/W] ---11111	ICR22 [R/W] ---11111	ICR23 [R/W] ---11111	
000458 <sub>H</sub>	ICR24 [R/W] ---11111	ICR25 [R/W] ---11111	ICR26 [R/W] ---11111	ICR27 [R/W] ---11111	
00045C <sub>H</sub>	ICR28 [R/W] ---11111	ICR29 [R/W] ---11111	ICR30 [R/W] ---11111	ICR31 [R/W] ---11111	
000460 <sub>H</sub>	ICR32 [R/W] ---11111	ICR33 [R/W] ---11111	ICR34 [R/W] ---11111	ICR35 [R/W] ---11111	
000464 <sub>H</sub>	ICR36 [R/W] ---11111	ICR37 [R/W] ---11111	ICR38 [R/W] ---11111	ICR39 [R/W] ---11111	
000468 <sub>H</sub>	ICR40 [R/W] ---11111	ICR41 [R/W] ---11111	ICR42 [R/W] ---11111	ICR43 [R/W] ---11111	
00046C <sub>H</sub>	ICR44 [R/W] ---11111	ICR45 [R/W] ---11111	ICR46 [R/W] ---11111	ICR47 [R/W] ---11111	
000470 <sub>H</sub>	ICR48 [R/W] ---11111	ICR49 [R/W] ---11111	ICR50 [R/W] ---11111	ICR51 [R/W] ---11111	
000474 <sub>H</sub>	ICR52 [R/W] ---11111	ICR53 [R/W] ---11111	ICR54 [R/W] ---11111	ICR55 [R/W] ---11111	
000478 <sub>H</sub>	ICR56 [R/W] ---11111	ICR57 [R/W] ---11111	ICR58 [R/W] ---11111	ICR59 [R/W] ---11111	
00047C <sub>H</sub>	ICR60 [R/W] ---11111	ICR61 [R/W] ---11111	ICR62 [R/W] ---11111	ICR63 [R/W] ---11111	
000480 <sub>H</sub>	RSRR [R/W] 10000000	STCR [R/W] 00110011	TBCR [R/W] 00XXX - 00	CTBR [W] XXXXXXXXXX	Clock Control
000484 <sub>H</sub>	CLKR [R/W] ---- 0000	WPR [W] XXXXXXXXXX	DIVR0 [R/W] 00000011	DIVR1 [R/W] 00000000	
000488 <sub>H</sub>	Reserved				Reserved

(Continued)

*(Continued)*

Address	Register				Block
	+ 0	+ 1	+ 2	+ 3	
00048C <sub>H</sub>	PLLDIVM [R/W] ---- 0000	PLLDIVN [R/W] -- 000000	PLLDIVG [R/W] ---- 0000	PLLMULG [W] 00000000	PLL Interface
000490 <sub>H</sub>	PLLCTRL [R/W] ---- 0000	Reserved			
000494 <sub>H</sub>	OSCC1 [R/W] ----- 010	OSCS1 [R/W] 00001111	OSCC2 [R/W] ----- 010	OSCS2 [R/W] 00001111	Main/Sub Oscillator Control
000498 <sub>H</sub>	PORTEN [R/W] ----- 00	Reserved			Port Input Enable Control
00049C <sub>H</sub>	Reserved				Reserved
0004A0 <sub>H</sub>	Reserved	WT CER [R/W] ----- 00	WT CR [R/W] 00000000 000 - 00 - 0		Real Time Clock (Watch Timer)
0004A4 <sub>H</sub>	Reserved	WT BR [R/W] --- XXXXX XXXXXXXX XXXXXXXX			
0004A8 <sub>H</sub>	WTHR [R/W] --- 00000	WT MR [R/W] -- 000000	WTSR [R/W] -- 000000	Reserved	
0004AC <sub>H</sub>	CSVTR [R/W] --- 00010	CSVCR [R/W] 00011100	CSCFG [R/W] 0X000000	CMCFG [R/W] 00000000	Clock- Supervisor / Selector / Monitor
0004B0 <sub>H</sub>	CUCR [R/W] ----- 0 -- 00		CUTD [R/W] 10000000 00000000		Calibration of Sub Clock
0004B4 <sub>H</sub>	CUTR1 [R] ----- 00000000		CUTR2 [R] 00000000 00000000		
0004B8 <sub>H</sub>	CMPR [R/W] -- 000010 11111101		Reserved	CMCR [R/W] - 001 -- 00	Clock Modulator
0004BC <sub>H</sub>	CMT1 [R/W] 00000000 1 --- 0000		CMT2 [R/W] -- 000000 -- 000000		
0004C0 <sub>H</sub>	CANPRE [R/W] 0 --- 0000	CANCKD [R/W] ----- 000*1	Reserved		CAN Clock Control
0004C4 <sub>H</sub>	LVSEL [R/W] 00000111	LVDET [R/W] 0000 0 - 00	HWVDE [R/W] ----- 00	HWWD [R/W, W] 00011000	Low Voltage Detection/Hardware Watchdog
0004C8 <sub>H</sub>	OSCRH [R/W] 000 -- 001	OSCRL [R/W] ----- 000	WPCRH [R/W] 00 --- 000	WPCRL [R/W] ----- 00	Main-/Sub-Oscillation Stabilisation Timer
0004CC <sub>H</sub>	OSCCR [R/W] ----- 0	Reserved	REGSEL [R/W] -- 000100	REGCTR [R/W] --- 0 -- 00	Main- Oscillation Standby Control Main-/Sub regulator Control
0004D0 <sub>H</sub> to 00063C <sub>H</sub>	Reserved				Reserved

*(Continued)*

(Continued)

Address	Register				Block
	+ 0	+ 1	+ 2	+ 3	
000640 <sub>H</sub>	ASR0 [R/W] 00000000 00000000		ACR0 [R/W] 1111**00 00100000*2		External Bus
000644 <sub>H</sub>	ASR1 [R/W] XXXXXXXX XXXXXXXX		ACR1 [R/W] XXXXXXXX XXXXXXXX		
000648 <sub>H</sub>	ASR2 [R/W] XXXXXXXX XXXXXXXX		ACR2 [R/W] XXXXXXXX XXXXXXXX		
00064C <sub>H</sub>	ASR3 [R/W] XXXXXXXX XXXXXXXX		ACR3 [R/W] XXXXXXXX XXXXXXXX		
000650 <sub>H</sub>	ASR4 [R/W] XXXXXXXX XXXXXXXX		ACR4 [R/W] XXXXXXXX XXXXXXXX		
000654 <sub>H</sub>	ASR5 [R/W] XXXXXXXX XXXXXXXX		ACR5 [R/W] XXXXXXXX XXXXXXXX		
000658 <sub>H</sub>	ASR6 [R/W] XXXXXXXX XXXXXXXX		ACR6 [R/W] XXXXXXXX XXXXXXXX		
00065C <sub>H</sub>	ASR7 [R/W] XXXXXXXX XXXXXXXX		ACR7 [R/W] XXXXXXXX XXXXXXXX		
000660 <sub>H</sub>	AWR0 [R/W] 01001111 11111011		AWR1 [R/W] XXXXXXXX XXXXXXXX		
000664 <sub>H</sub>	AWR2 [R/W] XXXXXXXX XXXXXXXX		AWR3 [R/W] XXXXXXXX XXXXXXXX		
000668 <sub>H</sub>	AWR4 [R/W] XXXXXXXX XXXXXXXX		AWR5 [R/W] XXXXXXXX XXXXXXXX		
00066C <sub>H</sub>	AWR6 [R/W] XXXXXXXX XXXXXXXX		AWR7 [R/W] XXXXXXXX XXXXXXXX		
000670 <sub>H</sub>	MCRA [R/W] XXXXXXXX	MCRB [R/W] XXXXXXXX	Reserved		
000674 <sub>H</sub>	Reserved				
000678 <sub>H</sub>	IORW0 [R/W] XXXXXXXX	IORW1 [R/W] XXXXXXXX	IORW2 [R/W] XXXXXXXX	Reserved	
00067C <sub>H</sub>	Reserved				
000680 <sub>H</sub>	CSER [R/W] 00000001	CHER [R/W] 11111111	Reserved	TCR [R/W] 0000**** *3	
000684 <sub>H</sub>	RCRH [R/W] 00XXXXXX	RCRL [R/W] XXXX0XXX	Reserved		
000688 <sub>H</sub> to 0007F8 <sub>H</sub>	Reserved				
0007FC <sub>H</sub>	Reserved	MODR [W] XXXXXXXX	Reserved		Mode Register

(Continued)

(Continued)

Address	Register				Block
	+ 0	+ 1	+ 2	+ 3	
000800 <sub>H</sub> to 000CFC <sub>H</sub>	Reserved				Reserved
000D00 <sub>H</sub>	PDRD00 [R] XXXXXXXX	PDRD01 [R] XXXXXXXX	PDRD02 [R] XXXXXXXX	PDRD03 [R] XXXXXXXX	R-bus Port Data Direct Read Register
000D04 <sub>H</sub>	PDRD04 [R] -----XX	PDRD05 [R] XXXXXXXX	PDRD06 [R] XXXXXXXX	PDRD07 [R] XXXXXXXX	
000D08 <sub>H</sub>	PDRD08 [R] XXXXXXXX	PDRD09 [R] XX -- XXXX	PDRD10 [R] - XXXXXX -	Reserved	
000D0C <sub>H</sub>	Reserved	PDRD13 [R] -----XXX	PDRD14 [R] XXXXXXXX	PDRD15 [R] ---- XXXX	
000D10 <sub>H</sub>	PDRD16 [R] XXXXXXXX	PDRD17 [R] XXXX ----	PDRD18 [R] - XXX - XXX	PDRD19 [R] - XXX - XXX	
000D14 <sub>H</sub>	PDRD20 [R] -----XXX	Reserved	PDRD22 [R] -- XX - X - X	PDRD23 [R] -- XXXXXX	
000D18 <sub>H</sub>	PDRD24 [R] XXXXXXXX	PDRD25 [R] XXXXXXXX	PDRD26 [R] XXXXXXXX	PDRD27 [R] XXXXXXXX	
000D1C <sub>H</sub>	Reserved	PDRD29 [R] XXXXXXXX	Reserved		
000D20 <sub>H</sub> to 000D3C <sub>H</sub>	Reserved				Reserved
000D40 <sub>H</sub>	DDR00 [R/W] 00000000	DDR01 [R/W] 00000000	DDR02 [R/W] 00000000	DDR03 [R/W] 00000000	R-bus Port Direction Register
000D44 <sub>H</sub>	DDR04 [R/W] -----00	DDR05 [R/W] 00000000	DDR06 [R/W] 00000000	DDR07 [R/W] 00000000	
000D48 <sub>H</sub>	DDR08 [R/W] 00000000	DDR09 [R/W] 00 -- 0000	DDR10 [R/W] - 000000 -	Reserved	
000D4C <sub>H</sub>	Reserved	DDR13 [R/W] -----000	DDR14 [R/W] 00000000	DDR15 [R/W] ---- 0000	
000D50 <sub>H</sub>	DDR16 [R/W] 00000000	DDR17 [R/W] 0000 ----	DDR18 [R/W] - 000 - 000	DDR19 [R/W] - 000 - 000	
000D54 <sub>H</sub>	DDR20 [R/W] -----000	Reserved	DDR22 [R/W] -- 00 - 0 - 0	DDR23 [R/W] -- 000000	
000D58 <sub>H</sub>	DDR24 [R/W] 00000000	DDR25 [R/W] 00000000	DDR26 [R/W] 00000000	DDR27 [R/W] 00000000	
000D5C <sub>H</sub>	Reserved	DDR29 [R/W] 00000000	Reserved		
000D60 <sub>H</sub> to 000D7C <sub>H</sub>	Reserved				Reserved

(Continued)



(Continued)

Address	Register				Block
	+ 0	+ 1	+ 2	+ 3	
000D80 <sub>H</sub>	PFR00 [R/W] 11111111	PFR01 [R/W] 11111111	PFR02 [R/W] 11111111	PFR03 [R/W] 11111111	R-bus Port Function Register
000D84 <sub>H</sub>	PFR04 [R/W] ----- 11	PFR05 [R/W] 11111111	PFR06 [R/W] 11111111	PFR07 [R/W] 11111111	
000D88 <sub>H</sub>	PFR08 [R/W] 11111111	PFR09 [R/W] 11 -- 1111	PFR10 [R/W] - 111111 -	Reserved	
000D8C <sub>H</sub>	Reserved	PFR13 [R/W] ----- 000	PFR14 [R/W] 00000000	PFR15 [R/W] ---- 0000	
000D90 <sub>H</sub>	PFR16 [R/W] 00000000	PFR17 [R/W] 0000 ----	PFR18 [R/W] - 000 - 000	PFR19 [R/W] - 000 - 000	
000D94 <sub>H</sub>	PFR20 [R/W] ----- 000	Reserved	PFR22 [R/W] -- 00 - 0 - 0	PFR23 [R/W] -- 000000	
000D98 <sub>H</sub>	PFR24 [R/W] 00000000	PFR25 [R/W] 00000000	PFR26 [R/W] 00000000	PFR27 [R/W] 00000000	
000D9C <sub>H</sub>	Reserved	PFR29 [R/W] 00000000	Reserved		
000DA0 <sub>H</sub> to 000DBC <sub>H</sub>	Reserved				Reserved
000DC0 <sub>H</sub>	EPFR00 [R/W] -----	EPFR01 [R/W] -----	EPFR02 [R/W] -----	EPFR03 [R/W] -----	R-bus Extra Port Function Register
000DC4 <sub>H</sub>	EPFR04 [R/W] -----	EPFR05 [R/W] -----	EPFR06 [R/W] -----	EPFR07 [R/W] -----	
000DC8 <sub>H</sub>	EPFR08 [R/W] -----	EPFR09 [R/W] -----	EPFR10 [R/W] -- 00 ----	Reserved	
000DCC <sub>H</sub>	Reserved	EPFR13 [R/W] ----- 0 --	EPFR14 [R/W] 00000000	EPFR15 [R/W] ---- 0000	
000DD0 <sub>H</sub>	EPFR16 [R/W] 0000 ----	EPFR17 [R/W] -----	EPFR18 [R/W] - 00 -- 00 -	EPFR19 [R/W] - 0 --- 0 --	
000DD4 <sub>H</sub>	EPFR20 [R/W] ----- 00 -	Reserved	EPFR22 [R/W] -----	EPFR23 [R/W] -----	
000DD8 <sub>H</sub>	EPFR24 [R/W] -----	EPFR25 [R/W] -----	EPFR26 [R/W] 00000000	EPFR27 [R/W] 00000000	
000DDC <sub>H</sub>	Reserved	EPFR29 [R/W] -----	Reserved		
000DE0 <sub>H</sub> to 000DFC <sub>H</sub>	Reserved				Reserved

(Continued)

*(Continued)*

Address	Register				Block
	+ 0	+ 1	+ 2	+ 3	
000E00 <sub>H</sub>	PODR00 [R/W] 00000000	PODR01 [R/W] 00000000	PODR02 [R/W] 00000000	PODR03 [R/W] 00000000	R-bus Port Output Drive Select Register
000E04 <sub>H</sub>	PODR04 [R/W] ----- 00	PODR05 [R/W] 00000000	PODR06 [R/W] 00000000	PODR07 [R/W] 00000000	
000E08 <sub>H</sub>	PODR08 [R/W] 00000000	PODR09 [R/W] 00 -- 0000	PODR10 [R/W] - 000000 -	Reserved	
000E0C <sub>H</sub>	Reserved	PODR13 [R/W] ----- 000	PODR14 [R/W] 00000000	PODR15 [R/W] ---- 0000	
000E10 <sub>H</sub>	PODR16 [R/W] 00000000	PODR17 [R/W] 0000 ----	PODR18 [R/W] - 000 - 000	PODR19 [R/W] - 000 - 000	
000E14 <sub>H</sub>	PODR20 [R/W] ----- 000	Reserved	PODR22 [R/W] -- 00 - 0 - 0	PODR23 [R/W] -- 000000	
000E18 <sub>H</sub>	PODR24 [R/W] 00000000	PODR25 [R/W] 00000000	PODR26 [R/W] 00000000	PODR27 [R/W] 00000000	
000E1C <sub>H</sub>	Reserved	PODR29 [R/W] 00000000	Reserved		
000E20 <sub>H</sub> to 000E3C <sub>H</sub>	Reserved				Reserved
000E40 <sub>H</sub>	PILR00 [R/W] 00000000	PILR01 [R/W] 00000000	PILR02 [R/W] 00000000	PILR03 [R/W] 00000000	R-bus Port Input Level Select Register
000E44 <sub>H</sub>	PILR04 [R/W] ----- 00	PILR05 [R/W] 00000000	PILR06 [R/W] 00000000	PILR07 [R/W] 00000000	
000E48 <sub>H</sub>	PILR08 [R/W] 00000000	PILR09 [R/W] 00 -- 0000	PILR10 [R/W] - 000000 -	Reserved	
000E4C <sub>H</sub>	Reserved	PILR13 [R/W] ----- 000	PILR14 [R/W] 00000000	PILR15 [R/W] ---- 0000	
000E50 <sub>H</sub>	PILR16 [R/W] 00000000	PILR17 [R/W] 0000 ----	PILR18 [R/W] - 000 - 000	PILR19 [R/W] - 000 - 000	
000E54 <sub>H</sub>	PILR20 [R/W] ----- 000	Reserved	PILR22 [R/W] -- 00 - 0 - 0	PILR23 [R/W] -- 000000	
000E58 <sub>H</sub>	PILR24 [R/W] 00000000	PILR25 [R/W] 00000000	PILR26 [R/W] 00000000	PILR27 [R/W] 00000000	
000E5C <sub>H</sub>	Reserved	PILR29 [R/W] 00000000	Reserved		
000E60 <sub>H</sub> to 000E7C <sub>H</sub>	Reserved				Reserved

*(Continued)*

(Continued)

Address	Register				Block
	+ 0	+ 1	+ 2	+ 3	
000E80 <sub>H</sub>	EPILR00 [R/W] 00000000	EPILR01 [R/W] 00000000	EPILR02 [R/W] 00000000	EPILR03 [R/W] 00000000	R-bus Extra Port Input Level Select Register
000E84 <sub>H</sub>	EPILR04 [R/W] ----- 00	EPILR05 [R/W] 00000000	EPILR06 [R/W] 00000000	EPILR07 [R/W] 00000000	
000E88 <sub>H</sub>	EPILR08 [R/W] 00000000	EPILR09 [R/W] 00 -- 0000	EPILR10 [R/W] - 000000 -	Reserved	
000E8C <sub>H</sub>	Reserved	EPILR13 [R/W] ----- 000	EPILR14 [R/W] 00000000	EPILR15 [R/W] ---- 0000	
000E90 <sub>H</sub>	EPILR16 [R/W] 00000000	EPILR17 [R/W] 0000 ----	EPILR18 [R/W] - 000 - 000	EPILR19 [R/W] - 000 - 000	
000E94 <sub>H</sub>	EPILR20 [R/W] ----- 000	Reserved	EPILR22 [R/W] -- 00 - 0 - 0	EPILR23 [R/W] -- 000000	
000E98 <sub>H</sub>	EPILR24 [R/W] 00000000	EPILR25 [R/W] 00000000	EPILR26 [R/W] 00000000	EPILR27 [R/W] 00000000	
000E9C <sub>H</sub>	Reserved	EPILR29 [R/W] 00000000	Reserved		
000EA0 <sub>H</sub> to 000EBC <sub>H</sub>	Reserved				Reserved
000EC0 <sub>H</sub>	PPER00 [R/W] 00000000	PPER01 [R/W] 00000000	PPER02 [R/W] 00000000	PPER03 [R/W] 00000000	R-bus Port Pull-Up/Down Enable Register
000EC4 <sub>H</sub>	PPER04 [R/W] ----- 00	PPER05 [R/W] 00000000	PPER06 [R/W] 00000000	PPER07 [R/W] 00000000	
000EC8 <sub>H</sub>	PPER08 [R/W] 00000000	PPER09 [R/W] 00 -- 0000	PPER10 [R/W] - 000000 -	Reserved	
000ECC <sub>H</sub>	Reserved	PPER13 [R/W] ----- 000	PPER14 [R/W] 00000000	PPER15 [R/W] ---- 0000	
000ED0 <sub>H</sub>	PPER16 [R/W] 00000000	PPER17 [R/W] 0000 ----	PPER18 [R/W] - 000 - 000	PPER19 [R/W] - 000 - 000	
000ED4 <sub>H</sub>	PPER20 [R/W] ----- 000	Reserved	PPER22 [R/W] -- 00 - 0 - 0	PPER23 [R/W] -- 000000	
000ED8 <sub>H</sub>	PPER24 [R/W] 00000000	PPER25 [R/W] 00000000	PPER26 [R/W] 00000000	PPER27 [R/W] 00000000	
000EDC <sub>H</sub>	Reserved	PPER29 [R/W] 00000000	Reserved		
000EE0 <sub>H</sub> to 000EFC <sub>H</sub>	Reserved				Reserved

(Continued)

(Continued)

Address	Register				Block
	+ 0	+ 1	+ 2	+ 3	
000F00 <sub>H</sub>	PPCR00 [R/W] 11111111	PPCR01 [R/W] 11111111	PPCR02 [R/W] 11111111	PPCR03 [R/W] 11111111	R-bus Port Pull-Up/Down Control Register
000F04 <sub>H</sub>	PPCR04 [R/W] ----- 11	PPCR05 [R/W] 11111111	PPCR06 [R/W] 11111111	PPCR07 [R/W] 11111111	
000F08 <sub>H</sub>	PPCR08 [R/W] 11111111	PPCR09 [R/W] 11 -- 1111	PPCR10 [R/W] - 111111 -	Reserved	
000F0C <sub>H</sub>	Reserved	PPCR13 [R/W] ----- 111	PPCR14 [R/W] 11111111	PPCR15 [R/W] ---- 1111	
000F10 <sub>H</sub>	PPCR16 [R/W] 11111111	PPCR17 [R/W] 1111 ----	PPCR18 [R/W] - 111 - 111	PPCR19 [R/W] - 111 - 111	
000F14 <sub>H</sub>	PPCR20 [R/W] ----- 111	Reserved	PPCR22 [R/W] -- 11 - 1 - 1	PPCR23 [R/W] -- 111111	
000F18 <sub>H</sub>	PPCR24 [R/W] 11111111	PPCR25 [R/W] 11111111	PPCR26 [R/W] 11111111	PPCR27 [R/W] 11111111	
000F1C <sub>H</sub>	Reserved	PPCR29 [R/W] 11111111	Reserved		
000F20 <sub>H</sub> to 000F3C <sub>H</sub>	Reserved				Reserved
001000 <sub>H</sub>	DMASA0 [R/W] XXXXXXXX XXXXXXXXXXX XXXXXXXXXXX XXXXXXXXXXX				DMAC
001004 <sub>H</sub>	DMADA0 [R/W] XXXXXXXX XXXXXXXXXXX XXXXXXXXXXX XXXXXXXXXXX				
001008 <sub>H</sub>	DMASA1 [R/W] XXXXXXXX XXXXXXXXXXX XXXXXXXXXXX XXXXXXXXXXX				
00100C <sub>H</sub>	DMADA1 [R/W] XXXXXXXX XXXXXXXXXXX XXXXXXXXXXX XXXXXXXXXXX				
001010 <sub>H</sub>	DMASA2 [R/W] XXXXXXXX XXXXXXXXXXX XXXXXXXXXXX XXXXXXXXXXX				
001014 <sub>H</sub>	DMADA2 [R/W] XXXXXXXX XXXXXXXXXXX XXXXXXXXXXX XXXXXXXXXXX				
001018 <sub>H</sub>	DMASA3 [R/W] XXXXXXXX XXXXXXXXXXX XXXXXXXXXXX XXXXXXXXXXX				
00101C <sub>H</sub>	DMADA3 [R/W] XXXXXXXX XXXXXXXXXXX XXXXXXXXXXX XXXXXXXXXXX				
001020 <sub>H</sub>	DMASA4 [R/W] XXXXXXXX XXXXXXXXXXX XXXXXXXXXXX XXXXXXXXXXX				
001024 <sub>H</sub>	DMADA4 [R/W] XXXXXXXX XXXXXXXXXXX XXXXXXXXXXX XXXXXXXXXXX				
001028 <sub>H</sub> to 001FFC <sub>H</sub>	Reserved				Reserved

(Continued)

*(Continued)*

Address	Register				Block
	+ 0	+ 1	+ 2	+ 3	
00200 <sub>H</sub> to 006FFC <sub>H</sub>	CY91F467Dx Flash-cache size is 8 Kbytes : 004000 <sub>H</sub> to 005FFC <sub>H</sub> CY91F465DA Flash-cache size is 8 Kbytes : 004000 <sub>H</sub> to 005FFC <sub>H</sub>				Flash-cache / I-RAM area
007000 <sub>H</sub>	FMCS [R/W] 01101000	FMCR [R] --- 00000	FCHCR [R/W] ----- 00 10000011		Flash Memory/ Flash-cache/ I-RAM Control Register
007004 <sub>H</sub>	FMWT [R/W] 11111111 11111111		FMWT2 [R] - 001 ----	FMPS [R/W] ----- 000	
007008 <sub>H</sub>	FMAC [R] 00000000 00000000 00000000 00000000				
00700C <sub>H</sub>	FCHA0 [R/W] ----- --- 00000 00000000 00000000				Flash-cache Non-cacheable area setting Register
007010 <sub>H</sub>	FCHA1 [R/W] ----- --- 00000 00000000 00000000				
007014 <sub>H</sub> to 007FFC <sub>H</sub>	Reserved				Reserved
008000 <sub>H</sub> to 00BFFC <sub>H</sub>	CY91F467Dx Boot-ROM size is 4 Kbytes : 00B000 <sub>H</sub> to 00BFFC <sub>H</sub> CY91F465DA Boot-ROM size is 4 Kbytes : 00B000 <sub>H</sub> to 00BFFC <sub>H</sub> (instruction access is 1 wait cycle, data access is 1 wait cycle)				Boot ROM area
00C000 <sub>H</sub>	CTRLR0 [R/W] 00000000 00000001		STATR0 [R/W] 00000000 00000000		CAN 0 Control Register
00C004 <sub>H</sub>	ERRCNT0 [R] 00000000 00000000		BTR0 [R/W] 00100011 00000001		
00C008 <sub>H</sub>	INTR0 [R] 00000000 00000000		TESTR0 [R/W] 00000000 X0000000		
00C00C <sub>H</sub>	BRPE0 [R/W] 00000000 00000000		Reserved		
00C010 <sub>H</sub>	IF1CREQ0 [R/W] 00000000 00000001		IF1CMSK0 [R/W] 00000000 00000000		CAN 0 IF 1 Register
00C014 <sub>H</sub>	IF1MSK20 [R/W] 11111111 11111111		IF1MSK10 [R/W] 11111111 11111111		
00C018 <sub>H</sub>	IF1ARB20 [R/W] 00000000 00000000		IF1ARB10 [R/W] 00000000 00000000		
00C01C <sub>H</sub>	IF1MCTR0 [R/W] 00000000 00000000		Reserved		

*(Continued)*

(Continued)

Address	Register				Block
	+ 0	+ 1	+ 2	+ 3	
00C020 <sub>H</sub>	IF1DTA10 [R/W] 00000000 00000000		IF1DTA20 [R/W] 00000000 00000000		CAN 0 IF 1 Register
00C024 <sub>H</sub>	IF1DTB10 [R/W] 00000000 00000000		IF1DTB20 [R/W] 00000000 00000000		
00C028 <sub>H</sub> , 00C02C <sub>H</sub>	Reserved				
00C030 <sub>H</sub>	IF1DTA20 [R/W] 00000000 00000000		IF1DTA10 [R/W] 00000000 00000000		
00C034 <sub>H</sub>	IF1DTB20 [R/W] 00000000 00000000		IF1DTB10 [R/W] 00000000 00000000		
00C038 <sub>H</sub> , 00C03C <sub>H</sub>	Reserved				
00C040 <sub>H</sub>	IF2CREQ0 [R/W] 00000000 00000001		IF2CMSK0 [R/W] 00000000 00000000		CAN 0 IF 2 Register
00C044 <sub>H</sub>	IF2MSK20 [R/W] 11111111 11111111		IF2MSK10 [R/W] 11111111 11111111		
00C048 <sub>H</sub>	IF2ARB20 [R/W] 00000000 00000000		IF2ARB10 [R/W] 00000000 00000000		
00C04C <sub>H</sub>	IF2MCTR0 [R/W] 00000000 00000000		Reserved		
00C050 <sub>H</sub>	IF2DTA10 [R/W] 00000000 00000000		IF2DTA20 [R/W] 00000000 00000000		
00C054 <sub>H</sub>	IF2DTB10 [R/W] 00000000 00000000		IF2DTB20 [R/W] 00000000 00000000		
00C058 <sub>H</sub> , 00C05C <sub>H</sub>	Reserved				
00C060 <sub>H</sub>	IF2DTA20 [R/W] 00000000 00000000		IF2DTA10 [R/W] 00000000 00000000		
00C064 <sub>H</sub>	IF2DTB20 [R/W] 00000000 00000000		IF2DTB10 [R/W] 00000000 00000000		
00C068 <sub>H</sub> to 00C07C <sub>H</sub>	Reserved				

(Continued)

(Continued)

Address	Register				Block
	+ 0	+ 1	+ 2	+ 3	
00C080 <sub>H</sub>	TREQR20 [R] 00000000 00000000		TREQR10 [R] 00000000 00000000		CAN 0 Status Flags
00C084 <sub>H</sub> to 00C08C <sub>H</sub>	Reserved				
00C090 <sub>H</sub>	NEWDT20 [R] 00000000 00000000		NEWDT10 [R] 00000000 00000000		
00C094 <sub>H</sub> to 00C09C <sub>H</sub>	Reserved				
00C0A0 <sub>H</sub>	INTPND20 [R] 00000000 00000000		INTPND10 [R] 00000000 00000000		
00C0A4 <sub>H</sub> to 00C0AC <sub>H</sub>	Reserved				
00C0B0 <sub>H</sub>	MSGVAL20 [R] 00000000 00000000		MSGVAL10 [R] 00000000 00000000		
00C0B4 <sub>H</sub> to 00C0FC <sub>H</sub>	Reserved				Reserved
00C100 <sub>H</sub>	CTRLR1 [R/W] 00000000 00000001		STATR1 [R/W] 00000000 00000000		CAN 1 Control Register
00C104 <sub>H</sub>	ERRCNT1 [R] 00000000 00000000		BTR1 [R/W] 00100011 00000001		
00C108 <sub>H</sub>	INTR1 [R] 00000000 00000000		TESTR1 [R/W] 00000000 X0000000		
00C10C <sub>H</sub>	BRPE1 [R/W] 00000000 00000000		Reserved		
00C110 <sub>H</sub>	IF1CREQ1 [R/W] 00000000 00000001		IF1CMSK1 [R/W] 00000000 00000000		CAN 1 IF 1 Register
00C114 <sub>H</sub>	IF1MSK21 [R/W] 11111111 11111111		IF1MSK11 [R/W] 11111111 11111111		
00C118 <sub>H</sub>	IF1ARB21 [R/W] 00000000 00000000		IF1ARB11 [R/W] 00000000 00000000		
00C11C <sub>H</sub>	IF1MCTR1 [R/W] 00000000 00000000		Reserved		
00C120 <sub>H</sub>	IF1DTA11 [R/W] 00000000 00000000		IF1DTA21 [R/W] 00000000 00000000		
00C124 <sub>H</sub>	IF1DTB11 [R/W] 00000000 00000000		IF1DTB21 [R/W] 00000000 00000000		

(Continued)

(Continued)

Address	Register				Block
	+ 0	+ 1	+ 2	+ 3	
00C128 <sub>H</sub> , 00C12C <sub>H</sub>	Reserved				CAN 1 IF 1 Register
00C130 <sub>H</sub>	IF1DTA21 [R/W] 00000000 00000000		IF1DTA11 [R/W] 00000000 00000000		
00C134 <sub>H</sub>	IF1DTB21 [R/W] 00000000 00000000		IF1DTB11 [R/W] 00000000 00000000		
00C138 <sub>H</sub> , 00C13C <sub>H</sub>	Reserved				
00C140 <sub>H</sub>	IF2CREQ1 [R/W] 00000000 00000001		IF2CMSK1 [R/W] 00000000 00000000		CAN 1 IF 2 Register
00C144 <sub>H</sub>	IF2MSK21 [R/W] 11111111 11111111		IF2MSK11 [R/W] 11111111 11111111		
00C148 <sub>H</sub>	IF2ARB21 [R/W] 00000000 00000000		IF2ARB11 [R/W] 00000000 00000000		
00C14C <sub>H</sub>	IF2MCTR1 [R/W] 00000000 00000000		Reserved		
00C150 <sub>H</sub>	IF2DTA11 [R/W] 00000000 00000000		IF2DTA21 [R/W] 00000000 00000000		
00C154 <sub>H</sub>	IF2DTB11 [R/W] 00000000 00000000		IF2DTB21 [R/W] 00000000 00000000		
00C158 <sub>H</sub> , 00C15C <sub>H</sub>	Reserved				
00C160 <sub>H</sub>	IF2DTA21 [R/W] 00000000 00000000		IF2DTA11 [R/W] 00000000 00000000		
00C164 <sub>H</sub>	IF2DTB21 [R/W] 00000000 00000000		IF2DTB11 [R/W] 00000000 00000000		
00C168 <sub>H</sub> to 00C17C <sub>H</sub>	Reserved				
00C180 <sub>H</sub>	TREQR21 [R] 00000000 00000000		TREQR11 [R] 00000000 00000000		CAN 1 Status Flags
00C184 <sub>H</sub> to 00C18C <sub>H</sub>	Reserved				
00C190 <sub>H</sub>	NEWDT21 [R] 00000000 00000000		NEWDT11 [R] 00000000 00000000		
00C194 <sub>H</sub> to 00C19C <sub>H</sub>	Reserved				

(Continued)



(Continued)

Address	Register				Block
	+ 0	+ 1	+ 2	+ 3	
00C1A0 <sub>H</sub>	INTPND21 [R] 00000000 00000000		INTPND11 [R] 00000000 00000000		CAN 1 Status Flags
00C1A4 <sub>H</sub> to 00C1AC <sub>H</sub>	Reserved				
00C1B0 <sub>H</sub>	MSGVAL21 [R] 00000000 00000000		MSGVAL11 [R] 00000000 00000000		
00C1B4 <sub>H</sub> to 00C1FC <sub>H</sub>	Reserved				
00C200 <sub>H</sub>	CTRLR2 [R/W] 00000000 00000001		STATR2 [R/W] 00000000 00000000		CAN 2 Control Register
00C204 <sub>H</sub>	ERRCNT2 [R] 00000000 00000000		BTR2 [R/W] 00100011 00000001		
00C208 <sub>H</sub>	INTR2 [R] 00000000 00000000		TESTR2 [R/W] 00000000 X0000000		
00C20C <sub>H</sub>	BRPE2 [R/W] 00000000 00000000		Reserved		
00C210 <sub>H</sub>	IF1CREQ2 [R/W] 00000000 00000001		IF1CMSK2 [R/W] 00000000 00000000		CAN 2 IF 1 Register
00C214 <sub>H</sub>	IF1MSK22 [R/W] 11111111 11111111		IF1MSK12 [R/W] 11111111 11111111		
00C218 <sub>H</sub>	IF1ARB22 [R/W] 00000000 00000000		IF1ARB12 [R/W] 00000000 00000000		
00C21C <sub>H</sub>	IF1MCTR2 [R/W] 00000000 00000000		Reserved		
00C220 <sub>H</sub>	IF1DTA12 [R/W] 00000000 00000000		IF1DTA22 [R/W] 00000000 00000000		
00C224 <sub>H</sub>	IF1DTB12 [R/W] 00000000 00000000		IF1DTB22 [R/W] 00000000 00000000		
00C228 <sub>H</sub> , 00C22C <sub>H</sub>	Reserved				
00C230 <sub>H</sub>	IF1DTA22 [R/W] 00000000 00000000		IF1DTA12 [R/W] 00000000 00000000		
00C234 <sub>H</sub>	IF1DTB22 [R/W] 00000000 00000000		IF1DTB12 [R/W] 00000000 00000000		
00C238 <sub>H</sub> , 00C23C <sub>H</sub>	Reserved				

(Continued)

(Continued)

Address	Register				Block
	+ 0	+ 1	+ 2	+ 3	
00C240 <sub>H</sub>	IF2CREQ2 [R/W] 00000000 00000001		IF2CMSK2 [R/W] 00000000 00000000		CAN 2 IF 2 Register
00C244 <sub>H</sub>	IF2MSK22 [R/W] 11111111 11111111		IF2MSK12 [R/W] 11111111 11111111		
00C248 <sub>H</sub>	IF2ARB22 [R/W] 00000000 00000000		IF2ARB12 [R/W] 00000000 00000000		
00C24C <sub>H</sub>	IF2MCTR2 [R/W] 00000000 00000000		Reserved		
00C250 <sub>H</sub>	IF2DTA12 [R/W] 00000000 00000000		IF2DTA22 [R/W] 00000000 00000000		
00C254 <sub>H</sub>	IF2DTB12 [R/W] 00000000 00000000		IF2DTB22 [R/W] 00000000 00000000		
00C258 <sub>H</sub> , 00C25C <sub>H</sub>	Reserved				
00C260 <sub>H</sub>	IF2DTA22 [R/W] 00000000 00000000		IF2DTA12 [R/W] 00000000 00000000		
00C264 <sub>H</sub>	IF2DTB22 [R/W] 00000000 00000000		IF2DTB12 [R/W] 00000000 00000000		
00C268 <sub>H</sub> to 00C27C <sub>H</sub>	Reserved				
00C280 <sub>H</sub>	TREQR22 [R] 00000000 00000000		TREQR12 [R] 00000000 00000000		CAN 2 Status Flags
00C284 <sub>H</sub> to 00C28C <sub>H</sub>	Reserved				
00C290 <sub>H</sub>	NEWDT22 [R] 00000000 00000000		NEWDT12 [R] 00000000 00000000		
00C294 <sub>H</sub> to 00C29C <sub>H</sub>	Reserved				
00C2A0 <sub>H</sub>	INTPND22 [R] 00000000 00000000		INTPND12 [R] 00000000 00000000		
00C2A4 <sub>H</sub> to 00C2AC <sub>H</sub>	Reserved				
00C2B0 <sub>H</sub>	MSGVAL22 [R] 00000000 00000000		MSGVAL12 [R] 00000000 00000000		

(Continued)

(Continued)

Address	Register				Block
	+ 0	+ 1	+ 2	+ 3	
00C2B4 <sub>H</sub> to 00EFFC <sub>H</sub>	Reserved				Reserved
00F000 <sub>H</sub>	BCTRL [R/W] ----- 11111100 00000000				EDSU / MPU
00F004 <sub>H</sub>	BSTAT [R/W] -----000 00000000 10 -- 0000				
00F008 <sub>H</sub>	BIAC [R] ----- 00000000 00000000				
00F00C <sub>H</sub>	BOAC [R] ----- 00000000 00000000				
00F010 <sub>H</sub>	BIRQ [R/W] ----- 00000000 00000000				
00F014 <sub>H</sub> to 00F01C <sub>H</sub>	Reserved				
00F020 <sub>H</sub>	BCR0 [R/W] ----- 00000000 00000000 00000000				
00F024 <sub>H</sub>	BCR1 [R/W] ----- 00000000 00000000 00000000				
00F028 <sub>H</sub>	BCR2 [R/W] ----- 00000000 00000000 00000000				
00F02C <sub>H</sub>	BCR3 [R/W] ----- 00000000 00000000 00000000				
00F030 <sub>H</sub> to 00F07C <sub>H</sub>	Reserved				Reserved
00F080 <sub>H</sub>	BAD0 [R/W] XXXXXXXX XXXXXXXX XXXXXXXX XXXXXXXX				EDSU / MPU
00F084 <sub>H</sub>	BAD1 [R/W] XXXXXXXX XXXXXXXX XXXXXXXX XXXXXXXX				
00F088 <sub>H</sub>	BAD2 [R/W] XXXXXXXX XXXXXXXX XXXXXXXX XXXXXXXX				
00F08C <sub>H</sub>	BAD3 [R/W] XXXXXXXX XXXXXXXX XXXXXXXX XXXXXXXX				
00F090 <sub>H</sub>	BAD4 [R/W] XXXXXXXX XXXXXXXX XXXXXXXX XXXXXXXX				
00F094 <sub>H</sub>	BAD5 [R/W] XXXXXXXX XXXXXXXX XXXXXXXX XXXXXXXX				
00F098 <sub>H</sub>	BAD6 [R/W] XXXXXXXX XXXXXXXX XXXXXXXX XXXXXXXX				

(Continued)

Address	Register				Block
	+ 0	+ 1	+ 2	+ 3	
00F09C <sub>H</sub>	BAD7 [R/W] XXXXXXXX XXXXXXXX XXXXXXXX XXXXXXXX				EDSU / MPU
00F0A0 <sub>H</sub>	BAD8 [R/W] XXXXXXXX XXXXXXXX XXXXXXXX XXXXXXXX				
00F0A4 <sub>H</sub>	BAD9 [R/W] XXXXXXXX XXXXXXXX XXXXXXXX XXXXXXXX				
00F0A8 <sub>H</sub>	BAD10 [R/W] XXXXXXXX XXXXXXXX XXXXXXXX XXXXXXXX				
00F0AC <sub>H</sub>	BAD11 [R/W] XXXXXXXX XXXXXXXX XXXXXXXX XXXXXXXX				
00F0B0 <sub>H</sub>	BAD12 [R/W] XXXXXXXX XXXXXXXX XXXXXXXX XXXXXXXX				
00F0B4 <sub>H</sub>	BAD13 [R/W] XXXXXXXX XXXXXXXX XXXXXXXX XXXXXXXX				
00F0B8 <sub>H</sub>	BAD14 [R/W] XXXXXXXX XXXXXXXX XXXXXXXX XXXXXXXX				
00F0BC <sub>H</sub>	BAD15 [R/W] XXXXXXXX XXXXXXXX XXXXXXXX XXXXXXXX				
00F0C0 <sub>H</sub> to 01FFFC <sub>H</sub>	Reserved				Reserved
020000 <sub>H</sub> to 02FFFC <sub>H</sub>	CY91F467Dx D-RAM size is 32 Kbytes : 028000 <sub>H</sub> to 02FFFC <sub>H</sub> CY91F465DA D-RAM size is 32 Kbytes : 028000 <sub>H</sub> to 02FFFC <sub>H</sub> (data access is 0 wait cycles)				D-RAM area
030000 <sub>H</sub> to 03FFFC <sub>H</sub>	CY91F467Dx ID-RAM size is 32 Kbytes : 030000 <sub>H</sub> to 037FFC <sub>H</sub> CY91F465DA ID-RAM size is 16 Kbytes : 030000 <sub>H</sub> to 033FFC <sub>H</sub> (instruction access is 0 wait cycles, data access is 1 wait cycle)				ID-RAM area

\*1 : depends on the number of available CAN channels

\*2 : ACR0 [11 : 10] depends on bus width setting in Mode vector fetch information

\*3 : TCR [3 : 0] INIT value = 0000, keeps value after RST

**12.2 Flash Memory and External Bus Area**

32bit Read/Write	dat[31:0]				dat[31:0]				Block
16bit Read/Write	dat[31:16]		dat[15:0]		dat[31:16]		dat[15:0]		
Address	Register								
	+ 0	+ 1	+ 2	+ 3	+ 4	+ 5	+ 6	+ 7	
040000 <sub>H</sub> to 05FFF8 <sub>H</sub>	SA8 (64KB, CY91F467Dx) External bus (CY91F465DA)				SA9 (64KB, CY91F467Dx) External bus (CY91F465DA)				ROMS0
060000 <sub>H</sub> to 07FFF8 <sub>H</sub>	SA10 (64KB, CY91F467Dx) External bus (CY91F465DA)				SA11 (64KB, CY91F467Dx) External bus (CY91F465DA)				ROMS1
080000 <sub>H</sub> to 09FFF8 <sub>H</sub>	SA12 (64KB)				SA13 (64KB)				ROMS2
0A0000 <sub>H</sub> to 0BFFF8 <sub>H</sub>	SA14 (64KB)				SA15 (64KB)				ROMS3
0C0000 <sub>H</sub> to 0DFFF8 <sub>H</sub>	SA16 (64KB)				SA17 (64KB)				ROMS4
0E0000 <sub>H</sub> to 0FFFF0 <sub>H</sub>	SA18 (64KB)				SA19 (64KB)				ROMS5
0FFFF8 <sub>H</sub>	FMV [R] 06 00 00 00H				FRV [R] 00 00 BF F8H				
100000 <sub>H</sub> to 11FFF8 <sub>H</sub>	SA20 (64KB, CY91F467Dx) External bus (CY91F465DA)				SA21 (64KB, CY91F467Dx) External bus (CY91F465DA)				ROMS6
120000 <sub>H</sub> to 13FFF8 <sub>H</sub>	SA22 (64KB, CY91F467Dx) External bus (CY91F465DA)				SA23 (64KB, CY91F467Dx) External bus (CY91F465DA)				
140000 <sub>H</sub> to 143FF8 <sub>H</sub>	SA0 (8KB, CY91F467Dx) Reserved (CY91F465DA)				SA1 (8KB, CY91F467Dx) Reserved (CY91F465DA)				ROMS7
144000 <sub>H</sub> to 147FF8 <sub>H</sub>	SA2 (8KB, CY91F467Dx) Reserved (CY91F465DA)				SA3 (8KB, CY91F467Dx) Reserved (CY91F465DA)				
148000 <sub>H</sub> to 14BFF8 <sub>H</sub>	SA4 (8KB, CY91F467Dx)				SA5 (8KB, CY91F467Dx)				
14C000 <sub>H</sub> to 14FFF8 <sub>H</sub>	SA6 (8KB, CY91F467Dx)				SA7 (8KB, CY91F467Dx)				
150000 <sub>H</sub> to 17FFF8 <sub>H</sub>	Reserved								

32bit Read/Write	dat[31:0]				dat[31:0]				
16bit Read/Write	dat[31:16]		dat[15:0]		dat[31:16]		dat[15:0]		
Address	Register								Block
	+ 0	+ 1	+ 2	+ 3	+ 4	+ 5	+ 6	+ 7	
180000 <sub>H</sub> to 1BFFF8 <sub>H</sub>	External Bus Area								ROMS8
1C0000 <sub>H</sub> to 1FFFF8 <sub>H</sub>									ROMS9
200000 <sub>H</sub> to 27FFF8 <sub>H</sub>									ROMS10
280000 <sub>H</sub> to 2FFFF8 <sub>H</sub>									ROMS11
300000 <sub>H</sub> to 37FFF8 <sub>H</sub>									ROMS12
380000 <sub>H</sub> to 3FFFF8 <sub>H</sub>									ROMS13
400000 <sub>H</sub> to 47FFF8 <sub>H</sub>									ROMS14
480000 <sub>H</sub> to 4FFFF8 <sub>H</sub>									ROMS15

Notes: Write operations to address 0FFFF8<sub>H</sub> and 0FFFFC<sub>H</sub> are not possible. When reading these addresses, the values shown above will be read.

On CY91F465DA, write access to the flash is only possible in 16-bit mode.

**13. Interrupt Vector Table**

Interrupt	Interrupt Number		Interrupt Level *1		Interrupt Vector *2		DMA Resource Number
	Decimal	Hexa-Decimal	Setting Register	Register Address	Offset	Default Vector Address	
Reset	0	00	—	—	3FC <sub>H</sub>	000FFFFC <sub>H</sub>	—
Mode vector	1	01	—	—	3F8 <sub>H</sub>	000FFFF8 <sub>H</sub>	—
System reserved	2	02	—	—	3F4 <sub>H</sub>	000FFFF4 <sub>H</sub>	—
System reserved	3	03	—	—	3F0 <sub>H</sub>	000FFFF0 <sub>H</sub>	—
System reserved	4	04	—	—	3EC <sub>H</sub>	000FFFE <sub>C</sub>	—
CPU supervisor mode (INT #5 instruction) *5	5	05	—	—	3E8 <sub>H</sub>	000FFFE8 <sub>H</sub>	—
Memory Protection exception *5	6	06	—	—	3E4 <sub>H</sub>	000FFFE4 <sub>H</sub>	—
System reserved	7	07	—	—	3E0 <sub>H</sub>	000FFFE0 <sub>H</sub>	—
System reserved	8	08	—	—	3DC <sub>H</sub>	000FFFD <sub>C</sub>	—
System reserved	9	09	—	—	3D8 <sub>H</sub>	000FFFD8 <sub>H</sub>	—
System reserved	10	0A	—	—	3D4 <sub>H</sub>	000FFFD4 <sub>H</sub>	—
System reserved	11	0B	—	—	3D0 <sub>H</sub>	000FFFD0 <sub>H</sub>	—
System reserved	12	0C	—	—	3CC <sub>H</sub>	000FFFC <sub>C</sub>	—
System reserved	13	0D	—	—	3C8 <sub>H</sub>	000FFFC8 <sub>H</sub>	—
Undefined instruction exception	14	0E	—	—	3C4 <sub>H</sub>	000FFFC4 <sub>H</sub>	—
NMI request	15	0F	F <sub>H</sub> fixed		3C0 <sub>H</sub>	000FFFC0 <sub>H</sub>	—
External Interrupt 0	16	10	ICR00	440 <sub>H</sub>	3BC <sub>H</sub>	000FFFB <sub>C</sub>	0, 16
External Interrupt 1	17	11			3B8 <sub>H</sub>	000FFFB8 <sub>H</sub>	1, 17
External Interrupt 2	18	12	ICR01	441 <sub>H</sub>	3B4 <sub>H</sub>	000FFFB4 <sub>H</sub>	2, 18
External Interrupt 3	19	13			3B0 <sub>H</sub>	000FFFB0 <sub>H</sub>	3, 19
External Interrupt 4	20	14	ICR02	442 <sub>H</sub>	3AC <sub>H</sub>	000FFFA <sub>C</sub>	20
External Interrupt 5	21	15			3A8 <sub>H</sub>	000FFFA8 <sub>H</sub>	21
External Interrupt 6	22	16	ICR03	443 <sub>H</sub>	3A4 <sub>H</sub>	000FFFA4 <sub>H</sub>	22
External Interrupt 7	23	17			3A0 <sub>H</sub>	000FFFA0 <sub>H</sub>	23
External Interrupt 8	24	18	ICR04	444 <sub>H</sub>	39C <sub>H</sub>	000FFF9 <sub>C</sub>	—
External Interrupt 9	25	19			398 <sub>H</sub>	000FFF98 <sub>H</sub>	—
External Interrupt 10	26	1A	ICR05	445 <sub>H</sub>	394 <sub>H</sub>	000FFF94 <sub>H</sub>	—
System reserved	27	1B			390 <sub>H</sub>	000FFF90 <sub>H</sub>	—
External Interrupt 12	28	1C	ICR06	446 <sub>H</sub>	38C <sub>H</sub>	000FFF8 <sub>C</sub>	—
External Interrupt 13	29	1D			388 <sub>H</sub>	000FFF88 <sub>H</sub>	—
External Interrupt 14	30	1E	ICR07	447 <sub>H</sub>	384 <sub>H</sub>	000FFF84 <sub>H</sub>	—
System reserved	31	1F			380 <sub>H</sub>	000FFF80 <sub>H</sub>	—

*(Continued)*

Interrupt	Interrupt Number		Interrupt Level *1		Interrupt Vector *2		DMA Resource Number
	Decimal	Hexa-Decimal	Setting Register	Register Address	Offset	Default Vector Address	
Reload Timer 0	32	20	ICR08	448 <sub>H</sub>	37C <sub>H</sub>	000FFF7C <sub>H</sub>	4, 32
Reload Timer 1	33	21			378 <sub>H</sub>	000FFF78 <sub>H</sub>	5, 33
Reload Timer 2	34	22	ICR09	449 <sub>H</sub>	374 <sub>H</sub>	000FFF74 <sub>H</sub>	34
Reload Timer 3	35	23			370 <sub>H</sub>	000FFF70 <sub>H</sub>	35
Reload Timer 4	36	24	ICR10	44A <sub>H</sub>	36C <sub>H</sub>	000FFF6C <sub>H</sub>	36
Reload Timer 5	37	25			368 <sub>H</sub>	000FFF68 <sub>H</sub>	37
Reload Timer 6	38	26	ICR11	44B <sub>H</sub>	364 <sub>H</sub>	000FFF64 <sub>H</sub>	38
Reload Timer 7	39	27			360 <sub>H</sub>	000FFF60 <sub>H</sub>	39
Free Run Timer 0	40	28	ICR12	44C <sub>H</sub>	35C <sub>H</sub>	000FFF5C <sub>H</sub>	40
Free Run Timer 1	41	29			358 <sub>H</sub>	000FFF58 <sub>H</sub>	41
Free Run Timer 2	42	2A	ICR13	44D <sub>H</sub>	354 <sub>H</sub>	000FFF54 <sub>H</sub>	42
Free Run Timer 3	43	2B			350 <sub>H</sub>	000FFF50 <sub>H</sub>	43
Free Run Timer 4	44	2C	ICR14	44E <sub>H</sub>	34C <sub>H</sub>	000FFF4C <sub>H</sub>	44
Free Run Timer 5	45	2D			348 <sub>H</sub>	000FFF48 <sub>H</sub>	45
Free Run Timer 6	46	2E	ICR15	44F <sub>H</sub>	344 <sub>H</sub>	000FFF44 <sub>H</sub>	46
Free Run Timer 7	47	2F			340 <sub>H</sub>	000FFF40 <sub>H</sub>	47
CAN 0	48	30	ICR16	450 <sub>H</sub>	33C <sub>H</sub>	000FFF3C <sub>H</sub>	—
CAN 1	49	31			338 <sub>H</sub>	000FFF38 <sub>H</sub>	—
CAN 2	50	32	ICR17	451 <sub>H</sub>	334 <sub>H</sub>	000FFF34 <sub>H</sub>	—
System reserved	51	33			330 <sub>H</sub>	000FFF30 <sub>H</sub>	—
System reserved	52	34	ICR18	452 <sub>H</sub>	32C <sub>H</sub>	000FFF2C <sub>H</sub>	—
System reserved	53	35			328 <sub>H</sub>	000FFF28 <sub>H</sub>	—
System reserved	54	36	ICR19	453 <sub>H</sub>	324 <sub>H</sub>	000FFF24 <sub>H</sub>	6, 48
System reserved	55	37			320 <sub>H</sub>	000FFF20 <sub>H</sub>	7, 49
System reserved	56	38	ICR20	454 <sub>H</sub>	31C <sub>H</sub>	000FFF1C <sub>H</sub>	8, 50
System reserved	57	39			318 <sub>H</sub>	000FFF18 <sub>H</sub>	9, 51
LIN-USART 2 RX	58	3A	ICR21	455 <sub>H</sub>	314 <sub>H</sub>	000FFF14 <sub>H</sub>	52
LIN-USART 2 TX	59	3B			310 <sub>H</sub>	000FFF10 <sub>H</sub>	53
System reserved	60	3C	ICR22	456 <sub>H</sub>	30C <sub>H</sub>	000FFF0C <sub>H</sub>	54
System reserved	61	3D			308 <sub>H</sub>	000FFF08 <sub>H</sub>	55
System reserved	62	3E	ICR23 *3	457 <sub>H</sub>	304 <sub>H</sub>	000FFF04 <sub>H</sub>	—
Delayed Interrupt	63	3F			300 <sub>H</sub>	000FFF00 <sub>H</sub>	—

*(Continued)*



Interrupt	Interrupt Number		Interrupt Level *1		Interrupt Vector *2		DMA Resource Number
	Decimal	Hexa-Decimal	Setting Register	Register Address	Offset	Default Vector Address	
System reserved *4	64	40	(ICR24)	(458 <sub>H</sub> )	2FC <sub>H</sub>	000FFEFCH	—
System reserved *4	65	41			2F8 <sub>H</sub>	000FFEF8 <sub>H</sub>	—
LIN-USART (FIFO) 4 RX	66	42	ICR25	459 <sub>H</sub>	2F4 <sub>H</sub>	000FFEF4 <sub>H</sub>	10, 56
LIN-USART (FIFO) 4 TX	67	43			2F0 <sub>H</sub>	000FFEF0 <sub>H</sub>	11, 57
LIN-USART (FIFO) 5 RX	68	44	ICR26	45A <sub>H</sub>	2EC <sub>H</sub>	000FFEECH	12, 58
LIN-USART (FIFO) 5 TX	69	45			2E8 <sub>H</sub>	000FFEE8 <sub>H</sub>	13, 59
LIN-USART (FIFO) 6 RX	70	46	ICR27	45B <sub>H</sub>	2E4 <sub>H</sub>	000FFEE4 <sub>H</sub>	60
LIN-USART (FIFO) 6 TX	71	47			2E0 <sub>H</sub>	000FFEE0 <sub>H</sub>	61
LIN-USART (FIFO) 7 RX	72	48	ICR28	45C <sub>H</sub>	2DC <sub>H</sub>	000FFEDCH	62
LIN-USART (FIFO) 7 TX	73	49			2D8 <sub>H</sub>	000FFED8 <sub>H</sub>	63
I <sup>2</sup> C 0 / I <sup>2</sup> C 2	74	4A	ICR29	45D <sub>H</sub>	2D4 <sub>H</sub>	000FFED4 <sub>H</sub>	—
I <sup>2</sup> C 3	75	4B			2D0 <sub>H</sub>	000FFED0 <sub>H</sub>	—
System reserved	76	4C	ICR30	45E <sub>H</sub>	2CC <sub>H</sub>	000FFECCH	64
System reserved	77	4D			2C8 <sub>H</sub>	000FFEC8 <sub>H</sub>	65
System reserved	78	4E	ICR31	45F <sub>H</sub>	2C4 <sub>H</sub>	000FFEC4 <sub>H</sub>	66
System reserved	79	4F			2C0 <sub>H</sub>	000FFEC0 <sub>H</sub>	67
System reserved	80	50	ICR32	460 <sub>H</sub>	2BC <sub>H</sub>	000FFEBCH	68
System reserved	81	51			2B8 <sub>H</sub>	000FFEB8 <sub>H</sub>	69
System reserved	82	52	ICR33	461 <sub>H</sub>	2B4 <sub>H</sub>	000FFEB4 <sub>H</sub>	70
System reserved	83	53			2B0 <sub>H</sub>	000FFEB0 <sub>H</sub>	71
System reserved	84	54	ICR34	462 <sub>H</sub>	2AC <sub>H</sub>	000FFEACH	72
System reserved	85	55			2A8 <sub>H</sub>	000FFEA8 <sub>H</sub>	73
System reserved	86	56	ICR35	463 <sub>H</sub>	2A4 <sub>H</sub>	000FFEA4 <sub>H</sub>	74
System reserved	87	57			2A0 <sub>H</sub>	000FFEA0 <sub>H</sub>	75
System reserved	88	58	ICR36	464 <sub>H</sub>	29C <sub>H</sub>	000FFE9CH	76
System reserved	89	59			298 <sub>H</sub>	000FFE98 <sub>H</sub>	77
System reserved	90	5A	ICR37	465 <sub>H</sub>	294 <sub>H</sub>	000FFE94 <sub>H</sub>	78
System reserved	91	5B			290 <sub>H</sub>	000FFE90 <sub>H</sub>	79
Input Capture 0	92	5C	ICR38	466 <sub>H</sub>	28C <sub>H</sub>	000FFE8CH	80
Input Capture 1	93	5D			288 <sub>H</sub>	000FFE88 <sub>H</sub>	81
Input Capture 2	94	5E	ICR39	467 <sub>H</sub>	284 <sub>H</sub>	000FFE84 <sub>H</sub>	82
Input Capture 3	95	5F			280 <sub>H</sub>	000FFE80 <sub>H</sub>	83

*(Continued)*

Interrupt	Interrupt Number		Interrupt Level *1		Interrupt Vector *2		DMA Resource Number
	Decimal	Hexa-Decimal	Setting Register	Register Address	Offset	Default Vector Address	
Input Capture 4	96	60	ICR40	468 <sub>H</sub>	27C <sub>H</sub>	000FFE7C <sub>H</sub>	84
Input Capture 5	97	61			278 <sub>H</sub>	000FFE78 <sub>H</sub>	85
Input Capture 6	98	62	ICR41	469 <sub>H</sub>	274 <sub>H</sub>	000FFE74 <sub>H</sub>	86
Input Capture 7	99	63			270 <sub>H</sub>	000FFE70 <sub>H</sub>	87
Output Compare 0	100	64	ICR42	46A <sub>H</sub>	26C <sub>H</sub>	000FFE6C <sub>H</sub>	88
Output Compare 1	101	65			268 <sub>H</sub>	000FFE68 <sub>H</sub>	89
Output Compare 2	102	66	ICR43	46B <sub>H</sub>	264 <sub>H</sub>	000FFE64 <sub>H</sub>	90
Output Compare 3	103	67			260 <sub>H</sub>	000FFE60 <sub>H</sub>	91
System reserved	104	68	ICR44	46C <sub>H</sub>	25C <sub>H</sub>	000FFE5C <sub>H</sub>	92
System reserved	105	69			258 <sub>H</sub>	000FFE58 <sub>H</sub>	93
System reserved	106	6A	ICR45	46D <sub>H</sub>	254 <sub>H</sub>	000FFE54 <sub>H</sub>	94
System reserved	107	6B			250 <sub>H</sub>	000FFE50 <sub>H</sub>	95
Sound Generator	108	6C	ICR46	46E <sub>H</sub>	24C <sub>H</sub>	000FFE4C <sub>H</sub>	—
Phase Frequency Modulator	109	6D			248 <sub>H</sub>	000FFE48 <sub>H</sub>	—
System reserved	110	6E	ICR47 *3	46F <sub>H</sub>	244 <sub>H</sub>	000FFE44 <sub>H</sub>	—
System reserved	111	6F			240 <sub>H</sub>	000FFE40 <sub>H</sub>	—
System reserved	112	70	ICR48	470 <sub>H</sub>	23C <sub>H</sub>	000FFE3C <sub>H</sub>	15, 96
System reserved	113	71			238 <sub>H</sub>	000FFE38 <sub>H</sub>	97
System reserved	114	72	ICR49	471 <sub>H</sub>	234 <sub>H</sub>	000FFE34 <sub>H</sub>	98
System reserved	115	73			230 <sub>H</sub>	000FFE30 <sub>H</sub>	99
PPG4	116	74	ICR50	472 <sub>H</sub>	22C <sub>H</sub>	000FFE2C <sub>H</sub>	100
PPG5	117	75			228 <sub>H</sub>	000FFE28 <sub>H</sub>	101
PPG6	118	76	ICR51	473 <sub>H</sub>	224 <sub>H</sub>	000FFE24 <sub>H</sub>	102
PPG7	119	77			220 <sub>H</sub>	000FFE20 <sub>H</sub>	103
PPG8	120	78	ICR52	474 <sub>H</sub>	21C <sub>H</sub>	000FFE1C <sub>H</sub>	104
PPG9	121	79			218 <sub>H</sub>	000FFE18 <sub>H</sub>	105
PPG10	122	7A	ICR53	475 <sub>H</sub>	214 <sub>H</sub>	000FFE14 <sub>H</sub>	106
PPG11	123	7B			210 <sub>H</sub>	000FFE10 <sub>H</sub>	107
PPG12	124	7C	ICR54	476 <sub>H</sub>	20C <sub>H</sub>	000FFE0C <sub>H</sub>	108
PPG13	125	7D			208 <sub>H</sub>	000FFE08 <sub>H</sub>	109
PPG14	126	7E	ICR55	477 <sub>H</sub>	204 <sub>H</sub>	000FFE04 <sub>H</sub>	110
PPG15	127	7F			200 <sub>H</sub>	000FFE00 <sub>H</sub>	111

*(Continued)*

(Continued)

Interrupt	Interrupt Number		Interrupt Level *1		Interrupt Vector *2		DMA Resource Number
	Decimal	Hexa-Decimal	Setting Register	Register Address	Offset	Default Vector Address	
Up/Down Counter 0	128	80	ICR56	478 <sub>H</sub>	1FC <sub>H</sub>	000FFDFC <sub>H</sub>	—
System reserved	129	81			1F8 <sub>H</sub>	000FFDF8 <sub>H</sub>	—
Up/Down Counter 2	130	82	ICR57	479 <sub>H</sub>	1F4 <sub>H</sub>	000FFDF4 <sub>H</sub>	—
Up/Down Counter 3	131	83			1F0 <sub>H</sub>	000FFDF0 <sub>H</sub>	—
Real Time Clock	132	84	ICR58	47A <sub>H</sub>	1EC <sub>H</sub>	000FFDEC <sub>H</sub>	—
Calibration Unit	133	85			1E8 <sub>H</sub>	000FFDE8 <sub>H</sub>	—
A/D Converter 0	134	86	ICR59	47B <sub>H</sub>	1E4 <sub>H</sub>	000FFDE4 <sub>H</sub>	14, 112
System reserved	135	87			1E0 <sub>H</sub>	000FFDE0 <sub>H</sub>	—
Alarm Comparator 0	136	88	ICR60	47C <sub>H</sub>	1DC <sub>H</sub>	000FFDDC <sub>H</sub>	—
System reserved	137	89			1D8 <sub>H</sub>	000FFDD8 <sub>H</sub>	—
Low Voltage Detection	138	8A	ICR61	47D <sub>H</sub>	1D4 <sub>H</sub>	000FFDD4 <sub>H</sub>	—
SMC Comparator 0 to 5	139	8B			1D0 <sub>H</sub>	000FFDD0 <sub>H</sub>	—
Timebase Overflow	140	8C	ICR62	47E <sub>H</sub>	1CC <sub>H</sub>	000FFDCC <sub>H</sub>	—
PLL Clock Gear	141	8D			1C8 <sub>H</sub>	000FFDC8 <sub>H</sub>	—
DMA Controller	142	8E	ICR63	47F <sub>H</sub>	1C4 <sub>H</sub>	000FFDC4 <sub>H</sub>	—
Main/Sub OSC stability wait	143	8F			1C0 <sub>H</sub>	000FFDC0 <sub>H</sub>	—
Security vector	144	90	—	—	1BC <sub>H</sub>	000FFDBC <sub>H</sub>	—
Used by the INT instruction.	145 to 255	91 to FF	—	—	1B8 <sub>H</sub> to 000 <sub>H</sub>	000FFDB8 <sub>H</sub> to 000FFC00 <sub>H</sub>	—

\*1 : The Interrupt Control Registers (ICRs) are located in the interrupt controller and set the interrupt level for each interrupt request. An ICR is provided for each interrupt request.

\*2 : The vector address for each EIT (exception, interrupt or trap) is calculated by adding the listed offset to the table base register value (TBR) . The TBR specifies the top of the EIT vector table. The addresses listed in the table are for the default TBR value (000FFC00<sub>H</sub>) . The TBR is initialized to this value by a reset. The TBR is set to 000FFC00<sub>H</sub> after the internal boot ROM is executed.

\*3 : ICR23 and ICR47 can be exchanged by setting the REALOS compatibility bit (addr 0C03<sub>H</sub> : IOS[0])

\*4 : Used by REALOS

\*5 : Memory Protection Unit (MPU) support

## 14. Recommended Settings

### 14.1 PLL and Clockgear Settings

Please note that for CY91F467Dx the core base clock frequencies are valid in the 1.8V operation mode of the Main regulator and Flash.

#### Recommended PLL Divider and Clockgear Settings

PLL Input (CLK) [MHz]	Frequency Parameter		Clockgear Parameter		PLL Output (X) [MHz]	Core Base Clock [MHz]	Remarks
	DIVM	DIVN	DIVG	MULG			
4	2	25	16	24	200	100	*1
4	2	24	16	24	192	96	
4	2	23	16	24	184	92	
4	2	22	16	24	176	88	
4	2	21	16	20	168	84	
4	2	20	16	20	160	80	
4	2	19	16	20	152	76	
4	2	18	16	20	144	72	
4	2	17	16	16	136	68	
4	2	16	16	16	128	64	
4	2	15	16	16	120	60	
4	2	14	16	16	112	56	
4	2	13	16	12	104	52	
4	2	12	16	12	96	48	
4	2	11	16	12	88	44	
4	4	10	16	24	160	40	
4	4	9	16	24	144	36	
4	4	8	16	24	128	32	
4	4	7	16	24	112	28	
4	6	6	16	24	144	24	
4	8	5	16	28	160	20	
4	10	4	16	32	160	16	
4	12	3	16	32	144	12	

\*1 This setting is not possible at CY91F467Dx

**14.2 Clock Modulator Settings**

The following table shows all possible settings for the Clock Modulator in a base clock frequency range from 32MHz up to 88MHz. The Flash access time settings need to be adjusted according to Fmax while the PLL and clockgear settings should be set according to base clock frequency.

**Clock Modulator Settings, Frequency Range and Supported Supply Voltage**

Modulation Degree (k)	Random No (N)	CMPR [hex]	Baseclk [MHz]	Fmin [MHz]	Fmax [MHz]	Remarks
1	3	026F	88	79.5	98.5	*1
1	3	026F	84	76.1	93.8	
1	3	026F	80	72.6	89.1	
1	5	02AE	80	68.7	95.8	
2	3	046E	80	68.7	95.8	
1	3	026F	76	69.1	84.5	
1	5	02AE	76	65.3	90.8	
1	7	02ED	76	62	98.1	*1
2	3	046E	76	65.3	90.8	
3	3	066D	76	62	98.1	*1
1	3	026F	72	65.5	79.9	
1	5	02AE	72	62	85.8	
1	7	02ED	72	58.8	92.7	
2	3	046E	72	62	85.8	
3	3	066D	72	58.8	92.7	
1	3	026F	68	62	75.3	
1	5	02AE	68	58.7	80.9	
1	7	02ED	68	55.7	87.3	
1	9	032C	68	53	95	
2	3	046E	68	58.7	80.9	
2	5	04AC	68	53	95	
3	3	066D	68	55.7	87.3	
4	3	086C	68	53	95	
1	3	026F	64	58.5	70.7	
1	5	02AE	64	55.3	75.9	
1	7	02ED	64	52.5	82	
1	9	032C	64	49.9	89.1	
1	11	036B	64	47.6	97.6	*1
2	3	046E	64	55.3	75.9	
2	5	04AC	64	49.9	89.1	

(Continued)

(Continued)

Modulation Degree (k)	Random No (N)	CMPR [hex]	Baseclk [MHz]	Fmin [MHz]	Fmax [MHz]	Remarks
3	3	066D	64	52.5	82	
4	3	086C	64	49.9	89.1	
5	3	0A6B	64	47.6	97.6	
1	3	026F	60	54.9	66.1	
1	5	02AE	60	51.9	71	
1	7	02ED	60	49.3	76.7	
1	9	032C	60	46.9	83.3	
1	11	036B	60	44.7	91.3	
2	3	046E	60	51.9	71	
2	5	04AC	60	46.9	83.3	
3	3	066D	60	49.3	76.7	
4	3	086C	60	46.9	83.3	
5	3	0A6B	60	44.7	91.3	
1	3	026F	56	51.4	61.6	
1	5	02AE	56	48.6	66.1	
1	7	02ED	56	46.1	71.4	
1	9	032C	56	43.8	77.6	
1	11	036B	56	41.8	84.9	
1	13	03AA	56	39.9	93.8	
2	3	046E	56	48.6	66.1	
2	5	04AC	56	43.8	77.6	
2	7	04EA	56	39.9	93.8	
3	3	066D	56	46.1	71.4	
3	5	06AA	56	39.9	93.8	
4	3	086C	56	43.8	77.6	
5	3	0A6B	56	41.8	84.9	
6	3	0C6A	56	39.9	93.8	
1	3	026F	52	47.8	57	
1	5	02AE	52	45.2	61.2	
1	7	02ED	52	42.9	66.1	
1	9	032C	52	40.8	71.8	
1	11	036B	52	38.8	78.6	
1	13	03AA	52	37.1	86.8	
1	15	03E9	52	35.5	96.9	*1
2	3	046E	52	45.2	61.2	

(Continued)

(Continued)

Modulation Degree (k)	Random No (N)	CMPR [hex]	Baseclk [MHz]	Fmin [MHz]	Fmax [MHz]	Remarks
2	5	04AC	52	40.8	71.8	
2	7	04EA	52	37.1	86.8	
3	3	066D	52	42.9	66.1	
3	5	06AA	52	37.1	86.8	
4	3	086C	52	40.8	71.8	
5	3	0A6B	52	38.8	78.6	
6	3	0C6A	52	37.1	86.8	
7	3	0E69	52	35.5	96.9	*1
1	3	026F	48	44.2	52.5	
1	5	02AE	48	41.8	56.4	
1	7	02ED	48	39.6	60.9	
1	9	032C	48	37.7	66.1	
1	11	036B	48	35.9	72.3	
1	13	03AA	48	34.3	79.9	
1	15	03E9	48	32.8	89.1	
2	3	046E	48	41.8	56.4	
2	5	04AC	48	37.7	66.1	
2	7	04EA	48	34.3	79.9	
3	3	066D	48	39.6	60.9	
3	5	06AA	48	34.3	79.9	
4	3	086C	48	37.7	66.1	
5	3	0A6B	48	35.9	72.3	
6	3	0C6A	48	34.3	79.9	
7	3	0E69	48	32.8	89.1	
1	3	026F	44	40.6	48.1	
1	5	02AE	44	38.4	51.6	
1	7	02ED	44	36.4	55.7	
1	9	032C	44	34.6	60.4	
1	11	036B	44	33	66.1	
1	13	03AA	44	31.5	73	
1	15	03E9	44	30.1	81.4	
2	3	046E	44	38.4	51.6	
2	5	04AC	44	34.6	60.4	
2	7	04EA	44	31.5	73	
2	9	0528	44	28.9	92.1	

(Continued)

(Continued)

Modulation Degree (k)	Random No (N)	CMPR [hex]	Baseclk [MHz]	Fmin [MHz]	Fmax [MHz]	Remarks
3	3	066D	44	36.4	55.7	
3	5	06AA	44	31.5	73	
4	3	086C	44	34.6	60.4	
4	5	08A8	44	28.9	92.1	
5	3	0A6B	44	33	66.1	
6	3	0C6A	44	31.5	73	
7	3	0E69	44	30.1	81.4	
8	3	1068	44	28.9	92.1	
1	3	026F	40	37	43.6	
1	5	02AE	40	34.9	46.8	
1	7	02ED	40	33.1	50.5	
1	9	032C	40	31.5	54.8	
1	11	036B	40	30	59.9	
1	13	03AA	40	28.7	66.1	
1	15	03E9	40	27.4	73.7	
2	3	046E	40	34.9	46.8	
2	5	04AC	40	31.5	54.8	
2	7	04EA	40	28.7	66.1	
2	9	0528	40	26.3	83.3	
3	3	066D	40	33.1	50.5	
3	5	06AA	40	28.7	66.1	
3	7	06E7	40	25.3	95.8	
4	3	086C	40	31.5	54.8	
4	5	08A8	40	26.3	83.3	
5	3	0A6B	40	30	59.9	
6	3	0C6A	40	28.7	66.1	
7	3	0E69	40	27.4	73.7	
8	3	1068	40	26.3	83.3	
9	3	1267	40	25.3	95.8	
1	3	026F	36	33.3	39.2	
1	5	02AE	36	31.5	42	
1	7	02ED	36	29.9	45.3	
1	9	032C	36	28.4	49.2	
1	11	036B	36	27.1	53.8	
1	13	03AA	36	25.8	59.3	

(Continued)



(Continued)

Modulation Degree (k)	Random No (N)	CMPR [hex]	Baseclk [MHz]	Fmin [MHz]	Fmax [MHz]	Remarks
1	15	03E9	36	24.7	66.1	
2	3	046E	36	31.5	42	
2	5	04AC	36	28.4	49.2	
2	7	04EA	36	25.8	59.3	
2	9	0528	36	23.7	74.7	
3	3	066D	36	29.9	45.3	
3	5	06AA	36	25.8	59.3	
3	7	06E7	36	22.8	85.8	
4	3	086C	36	28.4	49.2	
4	5	08A8	36	23.7	74.7	
5	3	0A6B	36	27.1	53.8	
6	3	0C6A	36	25.8	59.3	
7	3	0E69	36	24.7	66.1	
8	3	1068	36	23.7	74.7	
9	3	1267	36	22.8	85.8	
1	3	026F	32	29.7	34.7	
1	5	02AE	32	28	37.3	
1	7	02ED	32	26.6	40.2	
1	9	032C	32	25.3	43.6	
1	11	036B	32	24.1	47.7	
1	13	03AA	32	23	52.5	
1	15	03E9	32	22	58.6	
2	3	046E	32	28	37.3	
2	5	04AC	32	25.3	43.6	
2	7	04EA	32	23	52.5	
2	9	0528	32	21.1	66.1	
2	11	0566	32	19.5	89.1	
3	3	066D	32	26.6	40.2	
3	5	06AA	32	23	52.5	
3	7	06E7	32	20.3	75.9	
4	3	086C	32	25.3	43.6	
4	5	08A8	32	21.1	66.1	
5	3	0A6B	32	24.1	47.7	
5	5	0AA6	32	19.5	89.1	
6	3	0C6A	32	23	52.5	

(Continued)

(Continued)

Modulation Degree (k)	Random No (N)	CMPR [hex]	Baseclk [MHz]	Fmin [MHz]	Fmax [MHz]	Remarks
7	3	0E69	32	22	58.6	
8	3	1068	32	21.1	66.1	
9	3	1267	32	20.3	75.9	
10	3	1466	32	19.5	89.1	

\*1 : These settings are not possible at CY91F467Dx

## 15. Electrical Characteristics

### 15.1 Absolute Maximum Ratings

Parameter	Symbol	Rating		Unit	Remarks
		Min	Max		
Power supply slew rate	—	—	50	V/ms	
Power supply voltage 1*1	V <sub>DD5R</sub>	- 0.3	+ 6.0	V	
Power supply voltage 2*1	V <sub>DD5</sub>	- 0.3	+ 6.0	V	
Power supply voltage 3*1	HV <sub>DD5</sub>	- 0.3	+ 6.0	V	
Power supply voltage 4*1	V <sub>DD35</sub>	- 0.3	+ 6.0	V	
Relationship of the supply voltages	HV <sub>DD5</sub>	V <sub>DD5</sub> -0.3	V <sub>DD5</sub> +0.3	V	SMC mode
		V <sub>SS5</sub> -0.3	V <sub>DD5</sub> +0.3	V	General purpose port mode
	AV <sub>CC5</sub>	V <sub>DD5</sub> -0.3	V <sub>DD5</sub> +0.3	V	At least one pin of the Ports 25 to 29 (SMC, ANn) is used as digital input or output.
		V <sub>SS5</sub> -0.3	V <sub>DD5</sub> +0.3	V	All pins of the Ports 25 to 29 (SMC, ANn) follow the condition of V <sub>IA</sub>
Analog power supply voltage*1	AV <sub>CC5</sub>	- 0.3	+ 6.0	V	*2
Analog reference power supply voltage*1	AVRH5	- 0.3	+ 6.0	V	*2
Input voltage 1*1	V <sub>I1</sub>	V <sub>SS5</sub> - 0.3	V <sub>DD5</sub> + 0.3	V	
Input voltage 2*1	V <sub>I2</sub>	V <sub>SS5</sub> - 0.3	V <sub>DD35</sub> + 0.3	V	External bus
Input voltage 3*1	V <sub>I3</sub>	HV <sub>SS5</sub> - 0.3	HV <sub>DD5</sub> + 0.3	V	Stepper motor controller
Analog pin input voltage*1	V <sub>IA</sub>	AV <sub>SS5</sub> - 0.3	AV <sub>CC5</sub> + 0.3	V	
Output voltage 1*1	V <sub>O1</sub>	V <sub>SS5</sub> - 0.3	V <sub>DD5</sub> + 0.3	V	
Output voltage 2*1	V <sub>O2</sub>	V <sub>SS5</sub> - 0.3	V <sub>DD35</sub> + 0.3	V	External bus
Output voltage 3*1	V <sub>O3</sub>	HV <sub>SS5</sub> - 0.3	HV <sub>DD5</sub> + 0.3	V	Stepper motor controller
Maximum clamp current	I <sub>CLAMP</sub>	- 4.0	+ 4.0	mA	*3
Total maximum clamp current	∑  I <sub>CLAMP</sub>	—	20	mA	*3
“L” level maximum output current*4	I <sub>OL</sub>	—	10	mA	
		—	40	mA	Stepper motor controller
“L” level average output current*5	I <sub>OLAV</sub>	—	8	mA	
		—	30	mA	Stepper motor controller
“L” level total maximum output current	∑ I <sub>OL</sub>	—	100	mA	
		—	360	mA	Stepper motor controller
“L” level total average output current*6	∑ I <sub>OLAV</sub>	—	50	mA	
		—	230	mA	Stepper motor controller
“H” level maximum output current*4	I <sub>OH</sub>	—	- 10	mA	
		—	- 40	mA	Stepper motor controller
“H” level average output current*5	I <sub>OHAV</sub>	—	- 4	mA	
		—	- 30	mA	Stepper motor controller

Parameter	Symbol	Rating		Unit	Remarks
		Min	Max		
“H” level total maximum output current	$\Sigma I_{OH}$	—	- 100	mA	
		—	- 360	mA	Stepper motor controller
“H” level total average output current*6	$\Sigma I_{OHAV}$	—	- 25	mA	
		—	- 230	mA	Stepper motor controller
Power consumption	$P_D$	—	1000	mW	at $T_A = 105^\circ\text{C}$
Operating temperature	$T_A$	- 40	+ 105	$^\circ\text{C}$	
Storage temperature	$T_{stg}$	- 55	+ 150	$^\circ\text{C}$	

\*1 : The parameter is based on  $V_{SS5} = HV_{SS5} = AV_{SS5} = 0.0 \text{ V}$ .

\*2 :  $AV_{CC5}$  and  $AVRH5$  must not exceed  $V_{DD5} + 0.3 \text{ V}$ .

- \*3 :
- Use within recommended operating conditions.
  - Use with DC voltage (current).
  - +B signals are input signals that exceed the  $V_{DD5}$  voltage. +B signals should always be applied by connecting a limiting resistor or between the +B signal and the microcontroller.
  - The value of the limiting resistor should be set so that the current input to the microcontroller pin does not exceed the rated value at any time, either instantaneously or for an extended period, when the +B signal is input.
  - Note that when the microcontroller drive current is low, such as in the low power consumption modes, the +B input potential can increase the potential at the power supply pin via a protective diode, possibly affecting other devices.
  - Note that if the +B signal is input when the microcontroller is off (not fixed at 0 V), power is supplied through the +B input pin; therefore, the microcontroller may partially operate.
  - Note that if the +B signal is input at power-on, since the power is supplied through the pin, the power-on reset may not function in the power supply voltage.
  - Do not leave +B input pins open.
  - Example of recommended circuit :

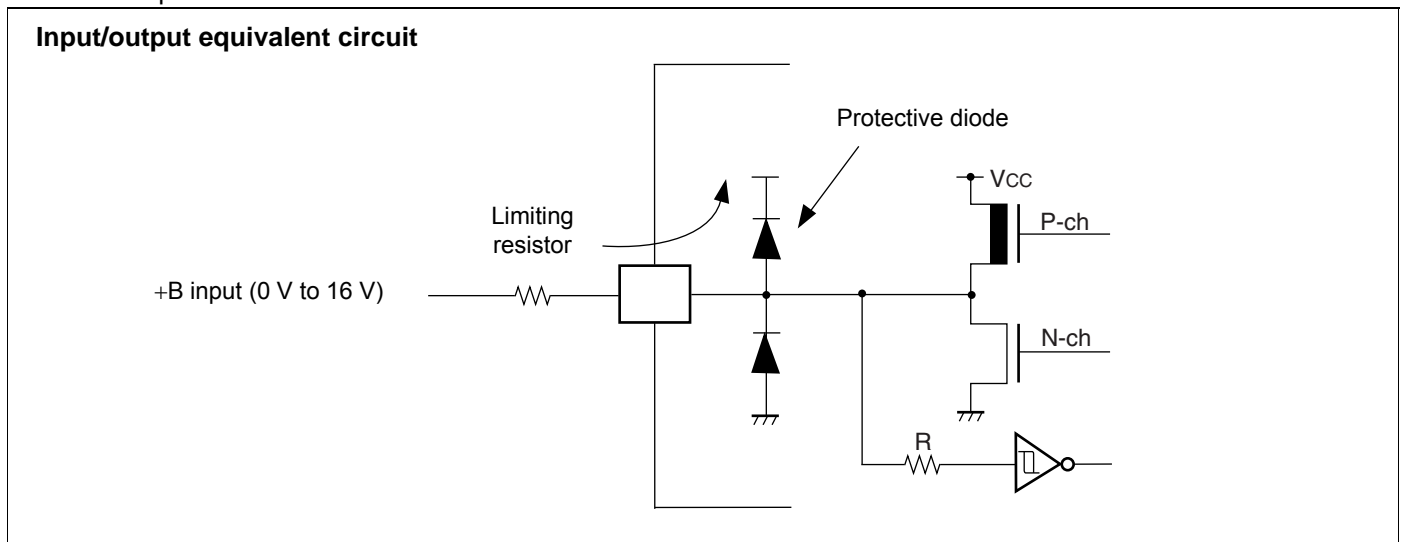

- \*4 : Maximum output current is defined as the value of the peak current flowing through any one of the corresponding pins.
- \*5 : Average output current is defined as the value of the average current flowing through any one of the corresponding pins for a 100 ms period.
- \*6 : Total average output current is defined as the value of the average current flowing through all of the corresponding pins for a 100 ms period.

**WARNING:** Semiconductor devices can be permanently damaged by application of stress (voltage, current, temperature, etc.) in excess of absolute maximum ratings. Do not exceed these ratings.

**15.2 Recommended Operating Conditions**
 $(V_{SS5} = AV_{SS5} = 0.0\text{ V})$ 

Parameter	Symbol	Value			Unit	Remarks
		Min	Typ	Max		
Power supply voltage	$V_{DD5}$	3.0	—	5.5	V	
	$V_{DD5R}$	3.0	—	5.5	V	Internal regulator
	$V_{DD35}$	3.0	—	5.5	V	External bus
	$HV_{DD5}$	4.5	—	5.5	V	Stepper motor controller
		3.0	—	5.5	V	Stepper motor controller (when all pins are used as general-purpose ports)
$AV_{CC5}$	3.0	—	5.5	V	A/D converter	
Smoothing capacitor at VCC18C pin	$C_S$	—	4.7	—	$\mu\text{F}$	Use a X7R ceramic capacitor or a capacitor that has similar frequency characteristics.
Power supply slew rate	—	—	—	50	V/ms	
Operating temperature	$T_A$	-40	—	+105	$^{\circ}\text{C}$	
Stepper motor control slew rate	—	—	40	—	ns	Load = 0 pF
Main Oscillation stabilisation time	—	10	—	—	ms	
Look-up time PLL (4 MHz -> 16 ... 100MHz)	—	—	—	0.6	ms	
ESD Protection (Human body model)	$V_{surge}$	2	—	—	kV	$R_{discharge} = 1.5\text{k}\Omega$ $C_{discharge} = 100\text{pF}$
RC Oscillator	$f_{RC100\text{kHz}}$	50	100	200	kHz	$V_{DDCORE} \geq 1.65\text{V}$
	$f_{RC2\text{MHz}}$	1	2	4	MHz	

**WARNING:** The recommended operating conditions are required in order to ensure the normal operation of the semiconductor device. All of the device's electrical characteristics are warranted when the device is operated within these ranges.

Always use semiconductor devices within their recommended operating condition ranges.

Operation outside these ranges may adversely affect reliability and could result in device failure.

No warranty is made with respect to uses, operating conditions, or combinations not represented on the data sheet. Users considering application outside the listed conditions are advised to contact their representatives beforehand.

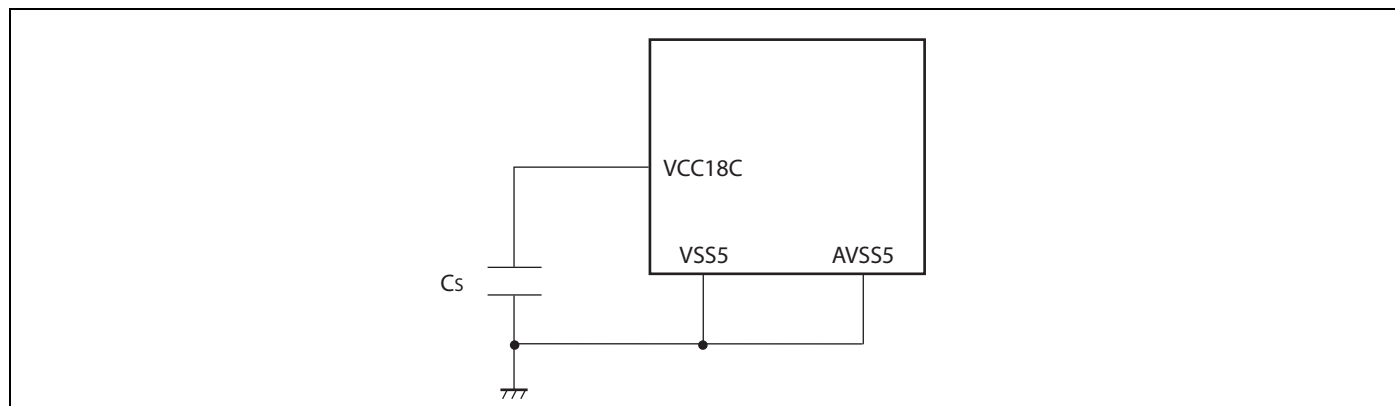

**15.3 DC Characteristics**

Note: In the following tables, “V<sub>DD</sub>” means V<sub>DD35</sub> for pins of ext. bus or HV<sub>DD5</sub> for SMC pins or V<sub>DD5</sub> for other pins.

In the following tables, “V<sub>SS</sub>” means Hv<sub>SS5</sub> for ground Pins of the stepper motor and V<sub>SS5</sub> for the other pins.

(V<sub>DD5</sub> = AV<sub>CC5</sub> = 3.0 V to 5.5 V, V<sub>SS5</sub> = AV<sub>SS5</sub> = 0 V, T<sub>A</sub> = -40°C to +105°C)

Parameter	Symbol	Pin Name	Condition	Value			Unit	Remarks
				Min	Typ	Max		
Input “H” voltage	V <sub>IH</sub>	—	Port inputs if CMOS Hysteresis 0.8/0.2 input is selected	0.8 × V <sub>DD</sub>	—	V <sub>DD</sub> + 0.3	V	CMOS hysteresis input
		—	Port inputs if CMOS Hysteresis 0.7/0.3 input is selected	0.7 × V <sub>DD</sub>	—	V <sub>DD</sub> + 0.3	V	4.5 V ≤ V <sub>DD</sub> ≤ 5.5 V
				0.74 × V <sub>DD</sub>	—	V <sub>DD</sub> + 0.3	V	3 V ≤ V <sub>DD</sub> < 4.5 V
		—	AUTOMOTIVE Hysteresis input is selected	0.8 × V <sub>DD</sub>	—	V <sub>DD</sub> + 0.3	V	
	—	Port inputs if TTL input is selected	2.0	—	V <sub>DD</sub> + 0.3	V		
	V <sub>IHR</sub>	INITX	—	0.8 × V <sub>DD</sub>	—	V <sub>DD</sub> + 0.3	V	INITX input pin (CMOS Hysteresis)
	V <sub>IHM</sub>	MD_2 to MD_0	—	V <sub>DD</sub> - 0.3	—	V <sub>DD</sub> + 0.3	V	Mode input pins
	V <sub>IHX0S</sub>	X0, X0A	—	2.5	—	V <sub>DD</sub> + 0.3	V	External clock in “Oscillation mode”
V <sub>IHX0F</sub>	X0	—	0.8 × V <sub>DD</sub>	—	V <sub>DD</sub> + 0.3	V	External clock in “Fast Clock Input mode”	
Input “L” voltage	V <sub>IL</sub>	—	Port inputs if CMOS Hysteresis 0.8/0.2 input is selected	V <sub>SS</sub> - 0.3	—	0.2 × V <sub>DD</sub>	V	
		—	Port inputs if CMOS Hysteresis 0.7/0.3 input is selected	V <sub>SS</sub> - 0.3	—	0.3 × V <sub>DD</sub>	V	
		—	Port inputs if AUTOMOTIVE Hysteresis input is selected	V <sub>SS</sub> - 0.3	—	0.5 × V <sub>DD</sub>	V	4.5 V ≤ V <sub>DD</sub> ≤ 5.5 V
				V <sub>SS</sub> - 0.3	—	0.46 × V <sub>DD</sub>	V	3 V ≤ V <sub>DD</sub> < 4.5 V
	—	Port inputs if TTL input is selected	V <sub>SS</sub> - 0.3	—	0.8	V		
	V <sub>ILR</sub>	INITX	—	V <sub>SS</sub> - 0.3	—	0.2 × V <sub>DD</sub>	V	INITX input pin (CMOS Hysteresis)
	V <sub>ILM</sub>	MD_2 to MD_0	—	V <sub>SS</sub> - 0.3	—	V <sub>SS</sub> + 0.3	V	Mode input pins
	V <sub>ILXDS</sub>	X0, X0A	—	V <sub>SS</sub> - 0.3	—	0.5	V	External clock in “Oscillation mode”

$(V_{DD5} = AV_{CC5} = 3.0\text{ V to } 5.5\text{ V}, V_{SS5} = AV_{SS5} = 0\text{ V}, T_A = -40^\circ\text{C to } +105^\circ\text{C})$ 

Parameter	Symbol	Pin Name	Condition	Value			Unit	Remarks
				Min	Typ	Max		
Input "L" voltage	$V_{ILXDF}$	X0	—	$V_{SS} - 0.3$	—	$0.2 \times V_{DD}$	V	External clock in "Fast Clock Input mode"
Output "H" voltage	$V_{OH2}$	Normal outputs	$4.5\text{V} \leq V_{DD} \leq 5.5\text{V}, I_{OH} = -2\text{mA}$	$V_{DD} - 0.5$	—	—	V	Driving strength set to 2 mA
			$3.0\text{V} \leq V_{DD} \leq 4.5\text{V}, I_{OH} = -1.6\text{mA}$					
	$V_{OH5}$	Normal outputs	$4.5\text{V} \leq V_{DD} \leq 5.5\text{V}, I_{OH} = -5\text{mA}$	$V_{DD} - 0.5$	—	—	V	Driving strength set to 5 mA
			$3.0\text{V} \leq V_{DD} \leq 4.5\text{V}, I_{OH} = -3\text{mA}$					
$V_{OH3}$	I <sup>2</sup> C outputs	$3.0\text{V} \leq V_{DD} \leq 5.5\text{V}, I_{OH} = -3\text{mA}$	$V_{DD} - 0.5$	—	—	V	See note *1	
$V_{OH30}$	High current outputs	$4.5\text{V} \leq V_{DD} \leq 5.5\text{V}, T_A = -40^\circ\text{C}, I_{OH} = -40\text{mA}$	$V_{DD} - 0.5$	—	—	V	Driving strength set to 30mA	
		$4.5\text{V} \leq V_{DD} \leq 5.5\text{V}, I_{OH} = -30\text{mA}$						
		$3.0\text{V} \leq V_{DD} \leq 4.5\text{V}, I_{OH} = -20\text{mA}$						
Output "L" voltage	$V_{OL2}$	Normal outputs	$4.5\text{V} \leq V_{DD} \leq 5.5\text{V}, I_{OH} = +2\text{mA}$	—	—	0.4	V	Driving strength set to 2 mA
			$3.0\text{V} \leq V_{DD} \leq 4.5\text{V}, I_{OH} = +1.6\text{mA}$					
	$V_{OL5}$	Normal outputs	$4.5\text{V} \leq V_{DD} \leq 5.5\text{V}, I_{OH} = +5\text{mA}$	—	—	0.4	V	Driving strength set to 5 mA
			$3.0\text{V} \leq V_{DD} \leq 4.5\text{V}, I_{OH} = +3\text{mA}$					
$V_{OL3}$	I <sup>2</sup> C outputs	$3.0\text{V} \leq V_{DD} \leq 5.5\text{V}, I_{OH} = +3\text{mA}$	—	—	0.4	V	See note *2	
$V_{OL30}$	High current outputs	$4.5\text{V} \leq V_{DD} \leq 5.5\text{V}, T_A = -40^\circ\text{C}, I_{OH} = +40\text{mA}$	—	—	0.5	V	Driving strength set to 30mA	
		$4.5\text{V} \leq V_{DD} \leq 5.5\text{V}, I_{OH} = +30\text{mA}$						
		$3.0\text{V} \leq V_{DD} \leq 4.5\text{V}, I_{OH} = +20\text{mA}$						
Input leakage current	$I_{IL}$	Pnn <sub>m</sub> <sup>*3</sup>	$3.0\text{V} \leq V_{DD} \leq 5.5\text{V}, V_{SS5} < V_I < V_{DD}, T_A = 25^\circ\text{C}$	-1	—	+1	μA	
			$3.0\text{V} \leq V_{DD} \leq 5.5\text{V}, V_{SS5} < V_I < V_{DD}, T_A = 105^\circ\text{C}$	-3	—	+3		



Parameter	Symbol	Pin Name	Condition	Value			Unit	Remarks
				Min	Typ	Max		
Analog input leakage current	$I_{AIN}$	ANn *4	$3.0V \leq V_{DD} \leq 5.5V$ $T_A=25^\circ C$	- 1	—	+ 1	$\mu A$	
			$3.0V \leq V_{DD} \leq 5.5V$ $T_A=105^\circ C$	- 3	—	+ 3	$\mu A$	
Pull-up resistance	$R_{UP}$	Pnn_m *5	$3.0V \leq V_{DD} \leq 3.6V$	40	100	160	k $\Omega$	
		INITX	$4.5V \leq V_{DD} \leq 5.5V$	25	50	100		
Pull-down resistance	$R_{DOWN}$	Pnn_m *6	$3.0V \leq V_{DD} \leq 3.6V$	40	100	180	k $\Omega$	
			$4.5V \leq V_{DD} \leq 5.5V$	25	50	100		
Input capacitance	$C_{IN}$	All except $V_{DD5}$ , $V_{DD5R}$ , $V_{SS5}$ , $AV_{CC5}$ , $AV_{SS}$ , $AVRH5$	$f = 1 \text{ MHz}$	-	5	15	$\mu F$	
Power supply current  CY91-F467Dx	$I_{CC}$	$V_{DD5R}$	CY91F467Dx: CLKB: 96 MHz CLKP: 48 MHz CLKT: 48 MHz CLKCAN: 48 MHz	—	120	150	mA	Code fetch from Flash
	$I_{CCH}$	$V_{DD5R}$	$T_A = +25^\circ C$	—	30	150	$\mu A$	At stop mode *7 *8
			$T_A = +105^\circ C$	—	400	2000	$\mu A$	
			$T_A = +25^\circ C$	—	100	500	$\mu A$	RTC : 4 MHz mode *7 *8
			$T_A = +105^\circ C$	—	500	2400	$\mu A$	
			$T_A = +25^\circ C$	—	50	250	$\mu A$	RTC : 100 kHz mode *7 *8
			$T_A = +105^\circ C$	—	450	2200	$\mu A$	
	$I_{LVE}$	$V_{DD5}$	—	—	70	150	$\mu A$	External low voltage detection
	$I_{LVI}$	$V_{DD5R}$	—	—	50	100	$\mu A$	Internal low voltage detection
$I_{OSC}$	$V_{DD5}$	—	—	250	500	$\mu A$	Main clock (4 MHz)	
		—	—	20	40	$\mu A$	Sub clock (32 kHz)	

Parameter	Symbol	Pin Name	Condition	Value			Unit	Remarks
				Min	Typ	Max		
Power supply current CY91-F465DA	$I_{CC}$	$V_{DD5R}$	CY91F465DA: CLKB: 100 MHz CLKP: 50 MHz CLKT: 50 MHz CLKCAN: 50 MHz	-	110	140	mA	Code fetch from Flash
	$I_{CCH}$	$V_{DD5R}$	$T_A = +25^{\circ}\text{C}$	-	30	150	$\mu\text{A}$	At stop mode *7
			$T_A = +105^{\circ}\text{C}$	-	300	2000	$\mu\text{A}$	
			$T_A = +25^{\circ}\text{C}$	-	100	500	$\mu\text{A}$	RTC : 4 MHz mode *7
			$T_A = +105^{\circ}\text{C}$	-	500	2400	$\mu\text{A}$	
			$T_A = +25^{\circ}\text{C}$	-	50	250	$\mu\text{A}$	RTC : 100 kHz mode *7
			$T_A = +105^{\circ}\text{C}$	-	400	2200	$\mu\text{A}$	
	$I_{LVE}$	$V_{DD5}$	-	-	70	150	$\mu\text{A}$	External low voltage detection
	$I_{LVI}$	$V_{DD5R}$	-	-	50	100	$\mu\text{A}$	Internal low voltage detection
	$I_{OSC}$	$V_{DD5}$	-	-	250	500	$\mu\text{A}$	Main clock (4 MHz)
-			-	20	40	$\mu\text{A}$	Sub clock (32 kHz)	

1. I2C Spec on CY91F467Dx only guaranteed for  $4.5\text{ V} < V_{DD5} < 5.5\text{ V}$ .
2. I2C Spec on CY91F467Dx only guaranteed for  $4.5\text{ V} < V_{DD5} < 5.5\text{ V}$ .
3. Pnn\_m includes all GPIO pins. Analog (AN) channels and PullUp/PullDown are disabled.
4. ANn includes all pins where AN channels are enabled.
5. Pnn\_m includes all GPIO pins. The pull up resistors must be enabled by PPER/PPCR setting and the pins must be in input direction.
6. Pnn\_m includes all GPIO pins. The pull down resistors must be enabled by PPER/PPCR setting and the pins must be in input direction.
7. Main regulator OFF, sub regulator set to 1.2V, Low voltage detection disabled.
8. On CY91F467Dx, the I2C pin consumes typical 200  $\mu\text{A}$  and maximal 400  $\mu\text{A}$  when "L" level is output, even if there is no load condition. When entering the standby mode while I2C outputs "L", the above-mentioned current is added to ICCH. The I2C pins are recommended to use for port input or external interrupt in standby mode.

**15.4 A/D Converter Characteristics**
 $(V_{DD5} = AV_{CC5} = 3.0 \text{ V to } 5.5 \text{ V}, V_{SS5} = AV_{SS5} = 0 \text{ V}, T_A = -40^\circ\text{C to } +105^\circ\text{C})$ 

Parameter	Symbol	Pin Name	Value			Unit	Remarks
			Min	Typ	Max		
Resolution	—	—	—	—	10	bit	
Total error	—	—	- 3	—	+ 3	LSB	
Nonlinearity error	—	—	- 2.5	—	+ 2.5	LSB	
Differential nonlinearity error	—	—	- 1.9	—	+ 1.9	LSB	
Zero reading voltage	$V_{OT}$	ANn	AVRL - 1.5 LSB	AVRL + 0.5 LSB	AVRL + 2.5 LSB	V	
Full scale reading voltage	$V_{FST}$	ANn	AVRH - 3.5 LSB	AVRH - 1.5 LSB	AVRH + 0.5 LSB	V	
Compare time	$T_{comp}$	—	0.6	—	16,500	$\mu\text{s}$	$4.5 \text{ V} \leq AV_{CC5} \leq 5.5 \text{ V}$
			2.0	—	—	$\mu\text{s}$	$3.0 \text{ V} \leq AV_{CC5} \leq 4.5 \text{ V}$
Sampling time	$T_{samp}$	—	0.4	—	—	$\mu\text{s}$	$4.5 \text{ V} \leq AV_{CC5} \leq 5.5 \text{ V}$ , $R_{EXT} < 2 \text{ k}\Omega$
			1.0	—	—	$\mu\text{s}$	$3.0 \text{ V} \leq AV_{CC5} \leq 4.5 \text{ V}$ , $R_{EXT} < 1 \text{ k}\Omega$
Conversion time	$T_{conv}$	—	1.0	—	—	$\mu\text{s}$	$4.5 \text{ V} \leq AV_{CC5} \leq 5.5 \text{ V}$
			3.0	—	—	$\mu\text{s}$	$3.0 \text{ V} \leq AV_{CC5} \leq 4.5 \text{ V}$
Input capacitance	$C_{IN}$	ANn	—	—	11	pF	
Input resistance	$R_{IN}$	ANn	—	—	2.6	k $\Omega$	$4.5 \text{ V} \leq AV_{CC5} \leq 5.5 \text{ V}$
			—	—	12.1	k $\Omega$	$3.0 \text{ V} \leq AV_{CC5} \leq 4.5 \text{ V}$
Analog input leakage current	$I_{AIN}$	ANn	- 1	—	+ 1	$\mu\text{A}$	$T_A = + 25^\circ\text{C}$
			- 3	—	+ 3	$\mu\text{A}$	$T_A = + 105^\circ\text{C}$
Analog input voltage range	$V_{AIN}$	ANn	AVRL	—	AVRH	V	
Offset between input channels	—	ANn	—	—	4	LSB	

*(Continued)*

Note : The accuracy gets worse as AVRH - AVRL becomes smaller

(Continued)

Parameter	Symbol	Pin Name	Value			Unit	Remarks
			Min	Typ	Max		
Reference voltage range	AVRH	AVRH5	$0.75 \times AV_{CC5}$	—	$AV_{CC5}$	V	
	AVRL	AV <sub>SS5</sub>	$AV_{SS5}$	—	$AV_{CC5} \times 0.25$	V	
Power supply current	$I_A$	$AV_{CC5}$	—	2.5	5	mA	A/D Converter active
	$I_{AH}$	$AV_{CC5}$	—	—	5	$\mu A$	A/D Converter not operated *1
Reference voltage current	$I_R$	AVRH5	—	0.7	1	mA	A/D Converter active
	$I_{RH}$	AVRH5	—	—	5	$\mu A$	A/D Converter not operated *2

\*1 : Supply current at  $AV_{CC5}$ , if A/D converter and ALARM comparator are not operating, ( $V_{DD5} = AV_{CC5} = AVRH = 5.0$  V)

\*2 : Input current at AVRH5, if A/D converter is not operating, ( $V_{DD5} = AV_{CC5} = AVRH = 5.0$  V)

#### Sampling Time Calculation

$$T_{\text{samp}} = (2.6 \text{ k}\Omega + R_{\text{EXT}}) \times 11 \text{ pF} \times 7; \text{ for } 4.5 \text{ V} \leq AV_{CC5} \leq 5.5 \text{ V}$$

$$T_{\text{samp}} = (12.1 \text{ k}\Omega + R_{\text{EXT}}) \times 11 \text{ pF} \times 7; \text{ for } 3.0 \text{ V} \leq AV_{CC5} \leq 4.5 \text{ V}$$

#### Conversion Time Calculation

$$T_{\text{conv}} = T_{\text{samp}} + T_{\text{comp}}$$

#### Definition of A/D converter terms

- Resolution  
Analog variation that is recognizable by the A/D converter.
- Nonlinearity error  
Deviation between actual conversion characteristics and a straight line connecting the zero transition point (00 0000 0000<sub>B</sub> ↔ 00 0000 0001<sub>B</sub>) and the full scale transition point (11 1111 1110<sub>B</sub> ↔ 11 1111 1111<sub>B</sub>).
- Differential nonlinearity error  
Deviation of the input voltage from the ideal value that is required to change the output code by 1 LSB.
- Total error  
This error indicates the difference between actual and theoretical values, including the zero transition error, full scale transition error, and nonlinearity error.

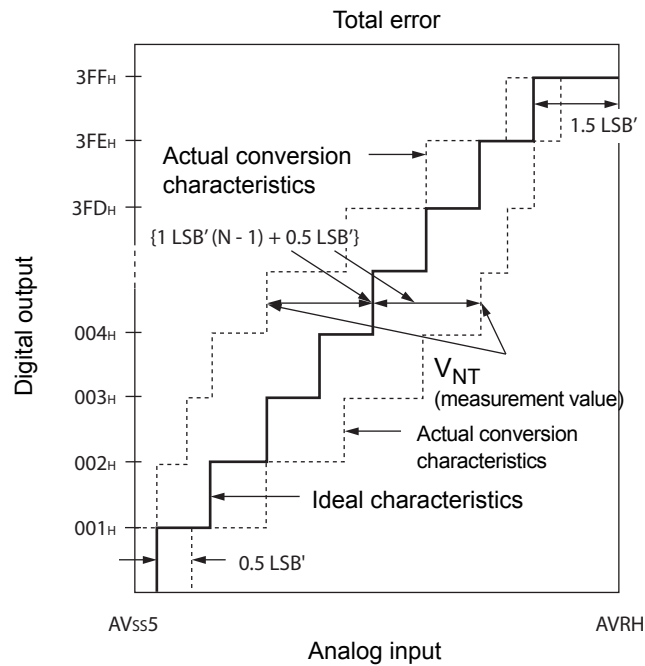

$$1\text{LSB}' (\text{ideal value}) = \frac{\text{AVRH} - \text{AV}_{\text{SS5}}}{1024} \text{ [V]}$$

$$\text{Total error of digital output } N = \frac{V_{\text{NT}} - \{1 \text{LSB}' \times (N - 1) + 0.5 \text{LSB}'\}}{1 \text{LSB}'}$$

N : A/D converter digital output value

$$V_{\text{OT}}' (\text{ideal value}) = \text{AV}_{\text{SS5}} + 0.5 \text{LSB}' \text{ [V]}$$

$$V_{\text{FST}}' (\text{ideal value}) = \text{AVRH} - 1.5 \text{LSB}' \text{ [V]}$$

V<sub>NT</sub> : Voltage at which the digital output changes from (N + 1)<sub>H</sub> to N<sub>H</sub>

(Continued)

(Continued)

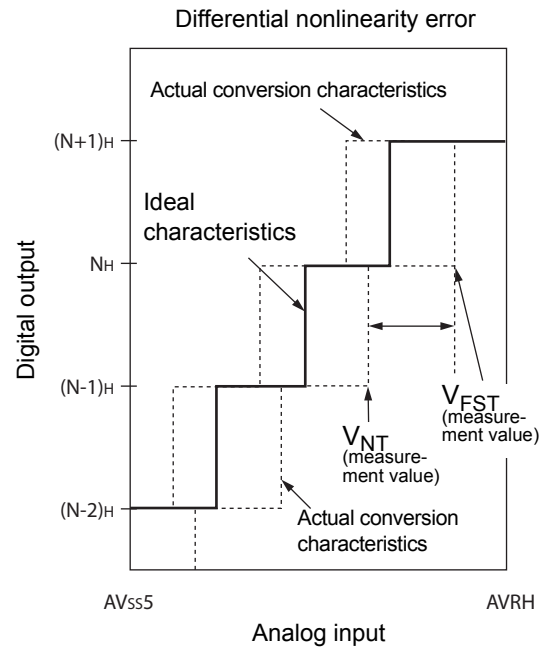
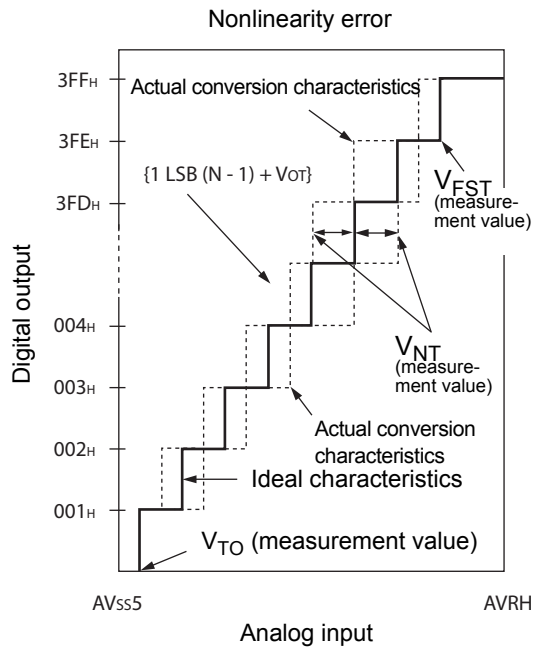

$$\text{Nonlinearity error of digital output } N = \frac{V_{NT} - \{1\text{LSB} \times (N - 1) + V_{OT}\}}{1\text{LSB}} \text{ [LSB]}$$

$$\text{Differential nonlinearity error of digital output } N = \frac{V_{(N+1)T} - V_{NT}}{1\text{LSB}} - 1 \text{ [LSB]}$$

$$1\text{LSB} = \frac{V_{FST} - V_{OT}}{1022} \text{ [V]}$$

N : A/D converter digital output value

V<sub>OT</sub> : Voltage at which the digital output changes from 000<sub>H</sub> to 001<sub>H</sub>.

V<sub>FST</sub> : Voltage at which the digital output changes from 3FE<sub>H</sub> to 3FF<sub>H</sub>.

**15.5 Alarm Comparator Characteristics**

Parameter	Symbol	Pin Name	Value			Unit	Remarks
			Min	Typ	Max		
Power supply current	$I_{A5ALMF}$	$AV_{CC5}$	—	25	40	$\mu A$	Alarm comparator enabled in fast mode (per channel) *1
	$I_{A5ALMS}$		—	7	10	$\mu A$	Alarm comparator enabled in normal mode (per channel) *1
	$I_{A5ALMH}$		—	—	5	$\mu A$	Alarm comparator disabled
ALARM pin input current	$I_{ALIN}$	ALARM_n	-1	—	+1	$\mu A$	$T_A=25^{\circ}C$
			-3	—	+3	$\mu A$	$T_A=105^{\circ}C$
ALARM pin input voltage range	$V_{ALIN}$		0	—	$AV_{CC5}$	V	
Alarm upper limit voltage	$V_{IAH}$		$AV_{CC5} \times 0.78$ -3%	$AV_{CC5} \times 0.78$	$AV_{CC5} \times 0.78$ +3%	V	
Alarm lower limit voltage	$V_{IAL}$		$AV_{CC5} \times 0.36$ -5%	$AV_{CC5} \times 0.36$	$AV_{CC5} \times 0.36$ +5%	V	
Alarm hysteresis voltage	$V_{IAHYS}$		50	—	250	mV	
Alarm input resistance	$R_{IN}$		5	—	—	M $\Omega$	
Comparison time	$t_{COMPF}$		—	0.1	0.2	$\mu s$	Alarm comparator enabled in fast mode *1
	$t_{COMPS}$	—	1	2	$\mu s$	Alarm comparator enabled in normal mode *1	

Note: \*1 : The fast Alarm Comparator mode is enabled by setting ACSR.MD=1  
Setting ACSR.MD = 0 sets the normal mode.

**15.6 FLASH Memory Program/Erase Characteristics**
**15.6.1 CY91F465DA**

 (T<sub>A</sub> = 25°C, V<sub>CC</sub> = 5.0V)

Parameter	Value			Unit	Remarks
	Min	Typ	Max		
Sector erase time	-	0.9	3.6	s	Erasure programming time not included
Chip erase time	-	n*0.9	n*3.6	s	n is the number of Flash sector of the device
Word (16-bit width) programming time	-	23	370	µs	System overhead time not included
Programme/Erase cycle	10 000	-	-	cycle	
Flash data retention time	20	-	-	year	*1

\*1: This value was converted from the results of evaluating the reliability of the technology (using Arrhenius equation to convert high temperature measurements into normalized value at 85°C)

**15.6.2 CY91F467Dx**

 (T<sub>A</sub> = 25°C, V<sub>CC</sub> = 5.0V)

Parameter	Value			Unit	Remarks
	Min	Typ	Max		
Sector erase time	-	0.5	2.0	s	Erasure programming time not included
Chip erase time	-	n*0.5	n*2.0	s	n is the number of Flash sector of the device
Word (16 or 32-bit width) programming time	-	6	100	µs	System overhead time not included
Programme/Erase cycle	10 000	-	-	cycle	
Flash data retention time	20	-	-	year	*1

\*1: This value was converted from the results of evaluating the reliability of the technology (using Arrhenius equation to convert high temperature measurements into normalized value at 85°C)



15.7 AC Characteristics

15.7.1 Clock Timing

( $V_{DD5} = 3.0\text{ V to }5.5\text{ V}$ ,  $V_{SS5} = AV_{SS5} = 0\text{ V}$ ,  $T_A = -40^\circ\text{C to }+105^\circ\text{C}$ )

Parameter	Symbol	Pin Name	Value			Unit	Condition
			Min	Typ	Max		
Clock frequency	$f_C$	X0 X1	3.5	4	16	MHz	Opposite phase external supply or crystal
		X0A X1A	32	32.768	100	kHz	

Clock Timing Condition

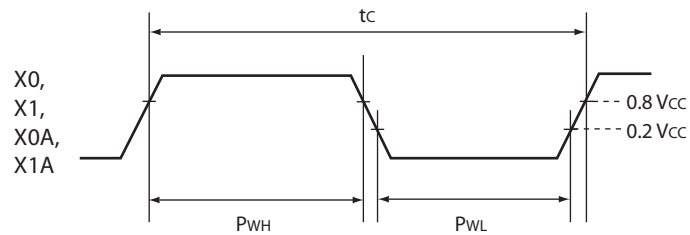

15.7.2 Reset Input Ratings

( $V_{DD5} = 3.0\text{ V to }5.5\text{ V}$ ,  $V_{SS5} = AV_{SS5} = 0\text{ V}$ ,  $T_A = -40^\circ\text{C to }+105^\circ\text{C}$ )

Parameter	Symbol	Pin Name	Condition	Value		Unit
				Min	Max	
INITX input time (at power-on)	$t_{INTL}$	INITX	—	8	—	ms
INITX input time (other than the above)				20	—	$\mu\text{s}$

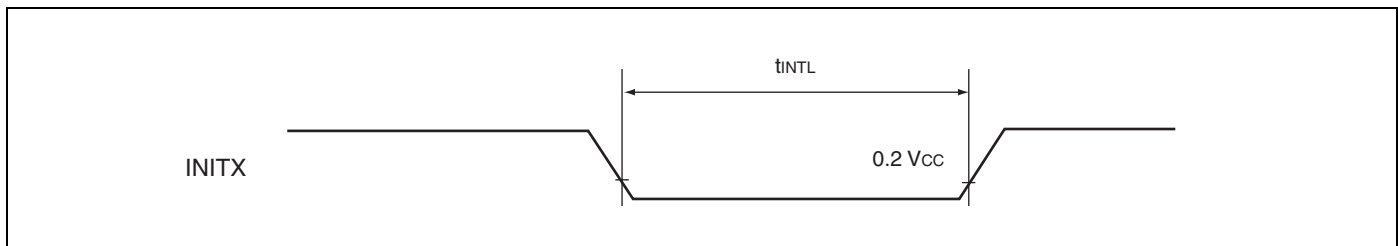

**15.7.3 LIN-USART Timings at  $V_{DD5} = 3.0$  to  $5.5$  V**

- Conditions during AC measurements
- All AC tests were measured under the following conditions:
  - -  $I_{Odrive} = 5$  mA
  - -  $V_{DD5} = 3.0$  V to  $5.5$  V,  $I_{load} = 3$  mA
  - -  $V_{SS5} = 0$  V
  - -  $T_a = -40^{\circ}\text{C}$  to  $+105^{\circ}\text{C}$
  - -  $C_l = 50$  pF (load capacity value of pins when testing)
  - -  $V_{OL} = 0.2 \times V_{DD5}$
  - -  $V_{OH} = 0.8 \times V_{DD5}$
  - - EPILR = 0, PILR = 1 (Automotive Level = worst case)

 $(V_{DD5} = 3.0$  V to  $5.5$  V,  $V_{SS5} = 0$  V,  $T_a = -40^{\circ}\text{C}$  to  $+105^{\circ}\text{C}$ )

Parameter	Symbol	Pin Name	Condition	$V_{DD5} = 3.0$ V to $4.5$ V		$V_{DD5} = 4.5$ V to $5.5$ V		Unit
				Min	Max	Min	Max	
Serial clock cycle time	$t_{SCYCI}$	SCKn	Internal clock operation (master mode)	$4 t_{CLKP}$	—	$4 t_{CLKP}$	—	ns
SCK $\downarrow \rightarrow$ SOT delay time	$t_{SLOVI}$	SCKn SOTn		- 30	30	- 20	20	ns
SOT $\rightarrow$ SCK $\downarrow$ delay time	$t_{OVSHI}$	SCKn SOTn		$m \times t_{CLKP} - 30^*$	—	$m \times t_{CLKP} - 20^*$	—	ns
Valid SIN $\rightarrow$ SCK $\uparrow$ setup time	$t_{IVSHI}$	SCKn SINn		$t_{CLKP} + 55$	—	$t_{CLKP} + 45$	—	ns
SCK $\uparrow \rightarrow$ valid SIN hold time	$t_{SHIXI}$	SCKn SINn		0	—	0	—	ns
Serial clock "H" pulse width	$t_{SHSLE}$	SCKn	External clock operation (slave mode)	$t_{CLKP} + 10$	—	$t_{CLKP} + 10$	—	ns
Serial clock "L" pulse width	$t_{SLSHE}$	SCKn		$t_{CLKP} + 10$	—	$t_{CLKP} + 10$	—	ns
SCK $\downarrow \rightarrow$ SOT delay time	$t_{SLOVE}$	SCKn SOTn		—	$2 t_{CLKP} + 55$	—	$2 t_{CLKP} + 45$	ns
Valid SIN $\rightarrow$ SCK $\uparrow$ setup time	$t_{IVSHE}$	SCKn SINn		10	—	10	—	ns
SCK $\uparrow \rightarrow$ valid SIN hold time	$t_{SHIXE}$	SCKn SINn		$t_{CLKP} + 10$	—	$t_{CLKP} + 10$	—	ns
SCK rising time	$t_{FE}$	SCKn		—	20	—	20	ns
SCK falling time	$t_{RE}$	SCKn		—	20	—	20	ns

\* : Parameter m depends on  $t_{SCYCI}$  and can be calculated as :

- if  $t_{SCYCI} = 2 \times k \times t_{CLKP}$ , then  $m = k$ , where k is an integer  $> 2$
- if  $t_{SCYCI} = (2 \times k + 1) \times t_{CLKP}$ , then  $m = k + 1$ , where k is an integer  $> 1$

Notes : • The above values are AC characteristics for CLK synchronous mode.  
•  $t_{CLKP}$  is the cycle time of the peripheral clock.

**Internal Clock Mode (Master Mode)**

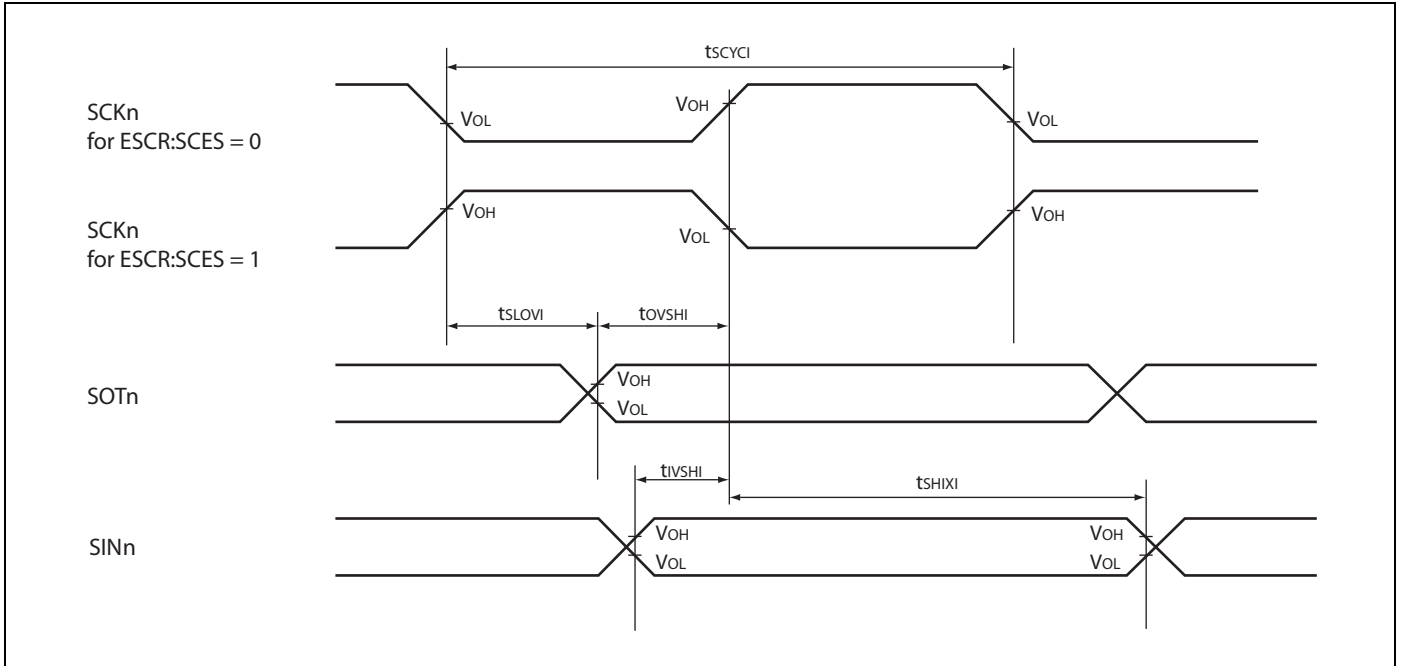

**External Clock Mode (Slave Mode)**

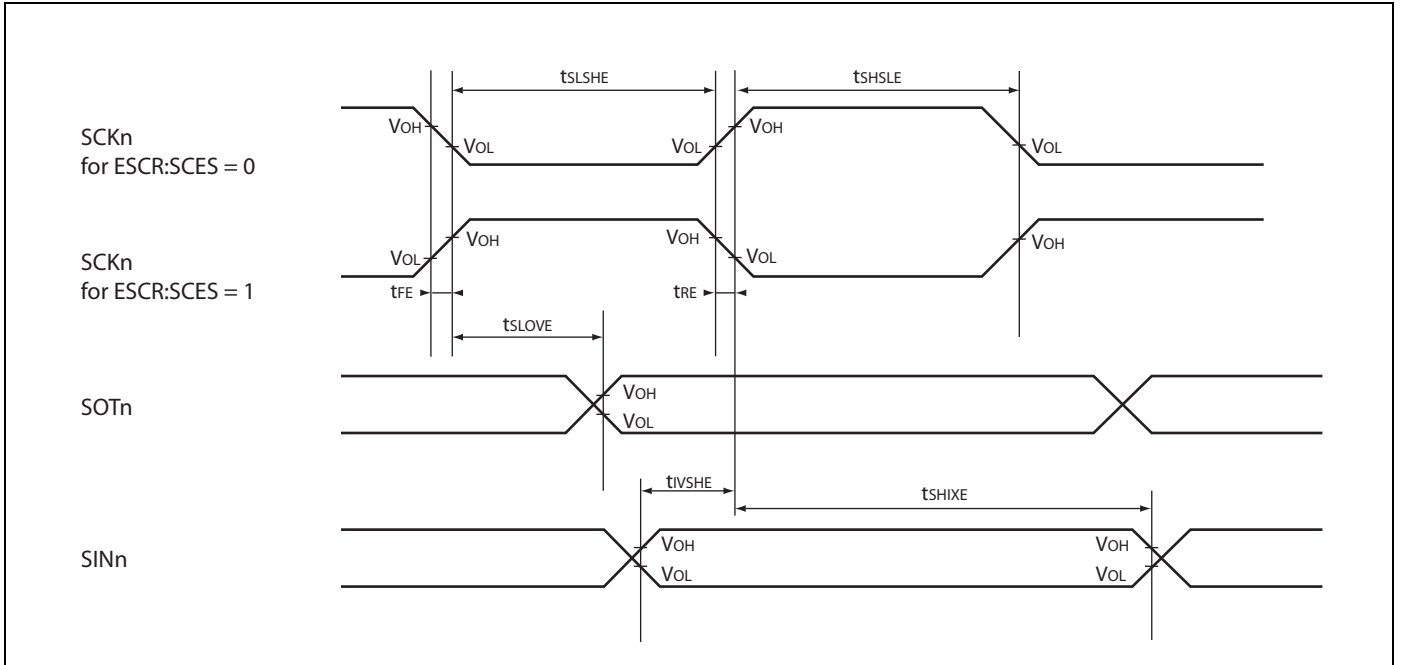

**15.7.4 I<sup>2</sup>C AC Timings at V<sub>DD5</sub> = 3.0 to 5.5 V**

- Conditions during AC measurements

All AC tests were measured under the following conditions:

- I<sub>Odrive</sub> = 3 mA
- V<sub>DD5</sub> = 3.0 V to 5.5 V, I<sub>load</sub> = 3 mA (V<sub>DD</sub> = 4.5 V to 5.5 V for CY91F467Dx)
- V<sub>SS5</sub> = 0 V
- T<sub>a</sub> = -40°C to +105°C
- C<sub>l</sub> = 50 pF
- VOL = 0.3 × V<sub>DD5</sub>
- VOH = 0.7 × V<sub>DD5</sub>
- EPILR = 0, PILR = 0 (CMOS Hysteresis 0.3 × V<sub>DD5</sub>/0.7 × V<sub>DD5</sub>)

Fast Mode:

(V<sub>DD5</sub> = 3.5 V to 5.5 V, V<sub>SS5</sub> = AV<sub>SS5</sub> = 0 V, T<sub>A</sub> = -40°C to +105°C)

Parameter	Symbol	Pin Name	Value		Unit	Remark
			Min	Max		
SCL clock frequency	f <sub>SCL</sub>	SCLn	0	400	kHz	
Hold time (repeated) START condition. After this period, the first clock pulse is generated	t <sub>HD;STA</sub>	SCLn, SDA <sub>n</sub>	0.6	—	μs	
LOW period of the SCL clock	t <sub>LOW</sub>	SCLn	1.3	—	μs	
HIGH period of the SCL clock	t <sub>HIGH</sub>	SCLn	0.6	—	μs	
Setup time for a repeated START condition	t <sub>SU;STA</sub>	SCLn, SDA <sub>n</sub>	0.6	—	μs	
Data hold time for I <sup>2</sup> C-bus devices	t <sub>HD;DAT</sub>	SCLn, SDA <sub>n</sub>	0	0.9	μs	
Data setup time	t <sub>SU;DAT</sub>	SCLn SDA <sub>n</sub>	100	—	ns	
Rise time of both SDA and SCL signals	t <sub>r</sub>	SCLn, SDA <sub>n</sub>	20 + 0.1Cb	300	ns	*1
Fall time of both SDA and SCL signals	t <sub>f</sub>	SCLn, SDA <sub>n</sub>	20 + 0.1Cb	300	ns	*1
Setup time for STOP condition	t <sub>SU;STO</sub>	SCLn, SDA <sub>n</sub>	0.6	—	μs	
Bus free time between a STOP and START condition	t <sub>BUF</sub>	SCLn, SDA <sub>n</sub>	1.3	—	μs	
Capacitive load for each bus line	C <sub>b</sub>	SCLn, SDA <sub>n</sub>	—	400	pF	
Pulse width of spike suppressed by input filter	t <sub>SP</sub>	SCLn, SDA <sub>n</sub>	0	(1..1.5) × t <sub>CLKP</sub>	ns	*2

\*1 : On CY91F467Dx only guaranteed for 4.5 V < V<sub>DD5</sub> < 5.5 V.

\*2 : The noise filter will suppress single spikes with a pulse width of 0ns and between (1 to 1.5) cycles of peripheral clock, depending on the phase relationship between I2C signals (SDA, SCL) and peripheral clock.

Note: t<sub>CLKP</sub> is the cycle time of the peripheral clock.

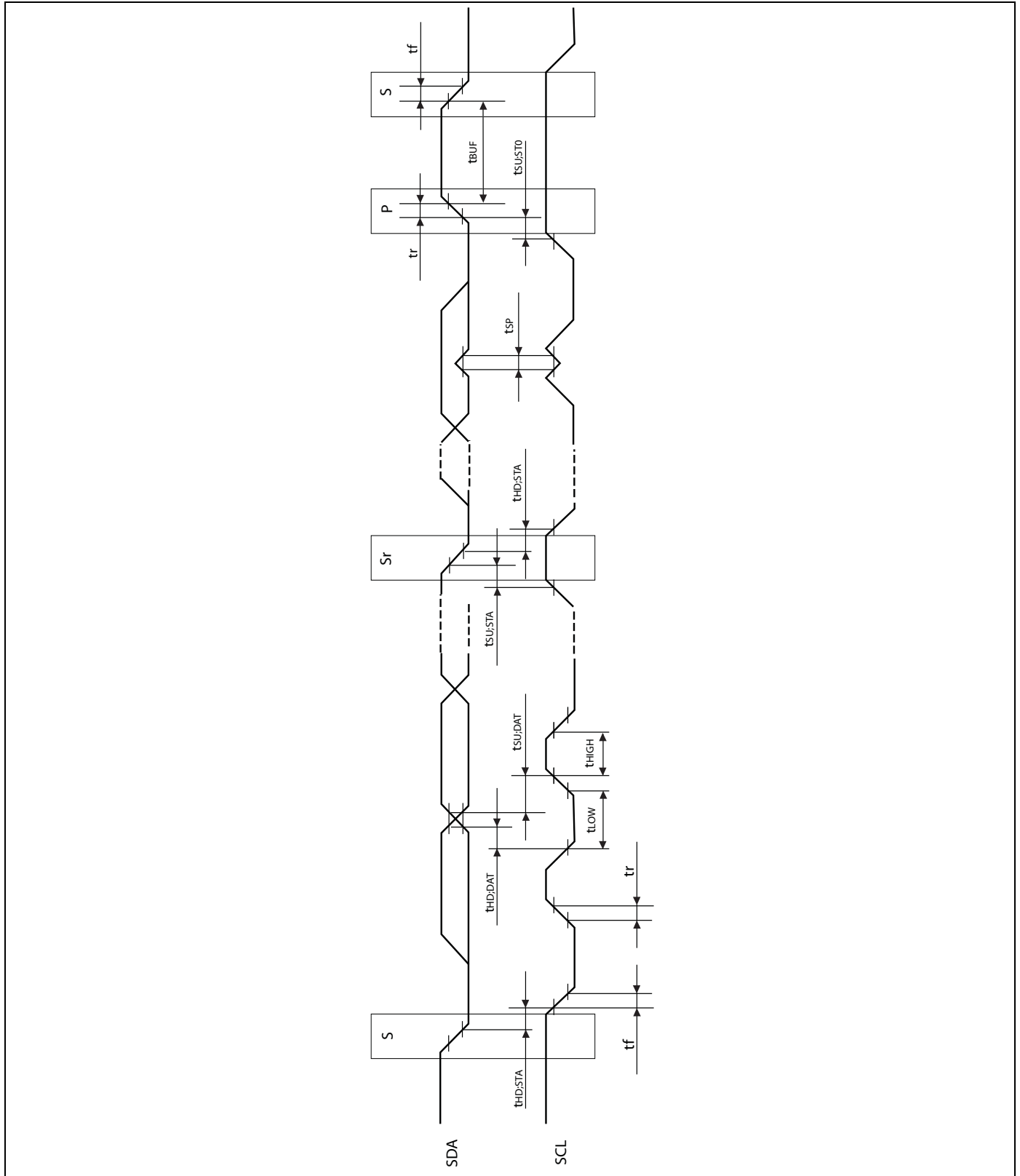

15.7.5 Free-run Timer Clock

( $V_{DD5} = 3.0\text{ V to } 5.5\text{ V}$ ,  $V_{SS5} = AV_{SS5} = 0\text{ V}$ ,  $T_A = -40^\circ\text{C to } +105^\circ\text{C}$ )

Parameter	Symbol	Pin Name	Condition	Value		Unit
				Min	Max	
Input pulse width	$t_{TIWH}$ $t_{TIWL}$	CKn	—	$4t_{CLKP}$	—	ns

Note :  $t_{CLKP}$  is the cycle time of the peripheral clock.

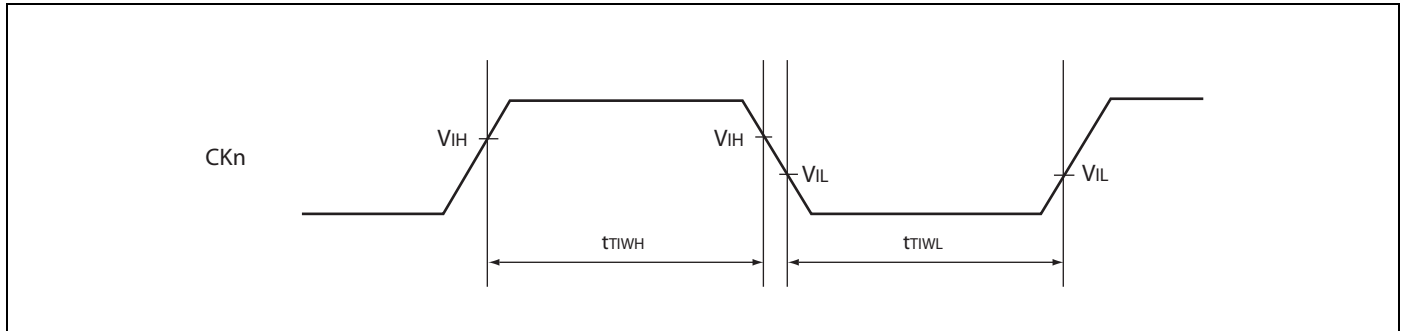

15.7.6 Trigger Input Timing

( $V_{DD5} = 3.0\text{ V to } 5.5\text{ V}$ ,  $V_{SS5} = AV_{SS5} = 0\text{ V}$ ,  $T_A = -40^\circ\text{C to } +105^\circ\text{C}$ )

Parameter	Symbol	Pin Name	Condition	Value		Unit
				Min	Max	
Input capture input trigger	$t_{INP}$	ICUn	—	$5t_{CLKP}$	—	ns
A/D converter trigger	$t_{ATGX}$	ATGX	—	$5t_{CLKP}$	—	ns

Note :  $t_{CLKP}$  is the cycle time of the peripheral clock.

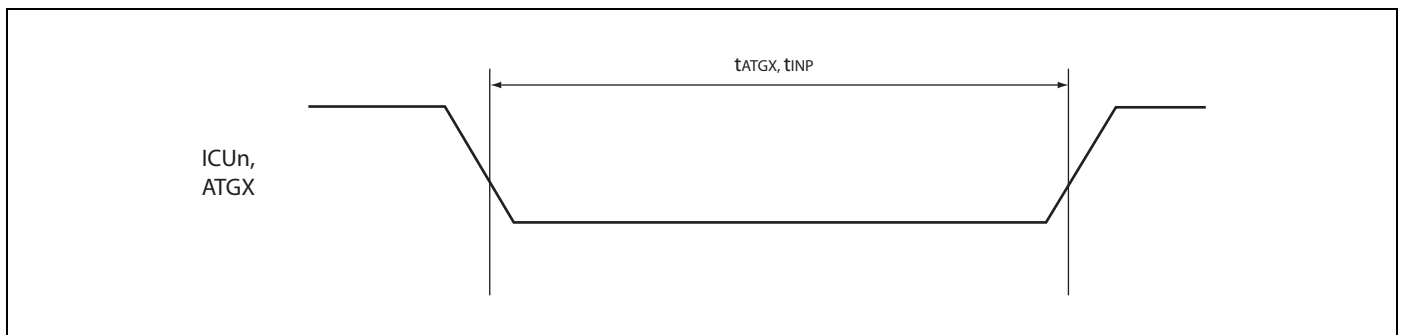

**15.7.7 External Bus AC Timings at  $V_{DD35} = 4.5$  to  $5.5$  V**

- Conditions during AC measurements

All AC tests were measured under the following conditions:

- $I_{Odrive} = 5$  mA
- $V_{DD35} = 4.5$  V to  $5.5$  V,  $I_{load} = 5$  mA
- $V_{SS5} = 0$  V
- $T_a = -40^{\circ}\text{C}$  to  $+105^{\circ}\text{C}$
- $C_l = 50$  pF
- $V_{OL} = 0.2 \times V_{DD35}$
- $V_{OH} = 0.8 \times V_{DD35}$
- $EPILR = 0$ ,  $PILR = 1$  (Automotive Level = worst case)

**Basic Timing**

( $V_{DD35} = 4.5$  V to  $5.5$  V,  $V_{SS5} = AV_{SS5} = 0$  V,  $T_A = -40^{\circ}\text{C}$  to  $+105^{\circ}\text{C}$ )

Parameter	Symbol	Pin Name	Value		Unit
			Min	Max	
MCLKO	$t_{CLCH}$	MCLKO	$1/2 \times t_{CLKT} - 7$	$1/2 \times t_{CLKT} + 7$	ns
	$t_{CHCL}$		$1/2 \times t_{CLKT} - 7$	$1/2 \times t_{CLKT} + 7$	ns
MCLKO ↓ to CSXn delay time	$t_{CLCSL}$	MCLKO CSXn	—	9	ns
	$t_{CLCSH}$		—	8	ns
MCLKO ↑ to CSXn delay time (Addr → CS delay)	$t_{CHCSL}$		— 5	+ 2	ns
MCLKO ↓ to ASX delay time	$t_{CLASL}$	MCLKO ASX	—	8	ns
	$t_{CLASH}$		—	8	ns
MCLKO ↓ to BAAX delay time	$t_{CLBAL}$	MCLKO BAAX	—	5	ns
	$t_{CLBAH}$		1	—	ns
MCLKO ↓ to Address valid delay time	$t_{CLAV}$	MCLKO A25 to A0	—	11	ns

Note :  $t_{CLKT}$  is the cycle time of the external bus clock.



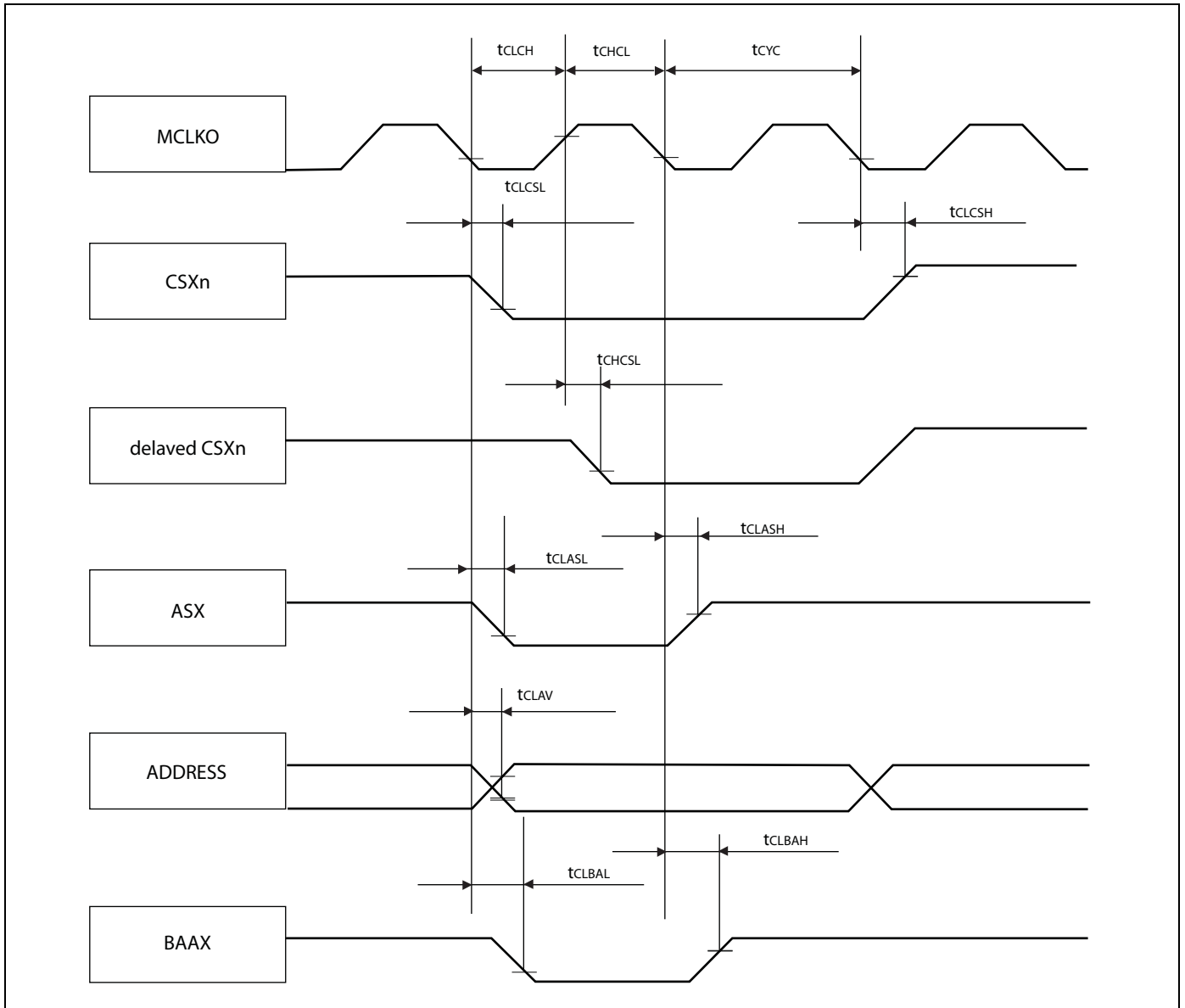

*Synchronous/Asynchronous Read Access With External Mclki Input*
 $(V_{DD35} = 4.5 \text{ V to } 5.5 \text{ V}, V_{SS5} = AV_{SS5} = 0 \text{ V}, T_A = -40^\circ\text{C to } +105^\circ\text{C})$ 

Parameter	Symbol	Pin Name	Value		Unit
			Min	Max	
MCLKO $\uparrow$ /MCLKI $\uparrow$ to RDX delay time	$t_{CHRL}$	MCLKO RDX	- 5	2	ns
	$t_{CHRH}$	MCLKI RDX	8	16	ns
Data valid to RDX $\uparrow$ setup time	$t_{DSRH}$	RDX D31 to D0	19	—	ns
RDX $\uparrow$ to Data valid hold time (external MCLKI input)	$t_{RHDX}$	RDX D31 to D0	0	—	ns
Data valid to MCLKI $\uparrow$ setup time	$t_{DSCH}$	MCLKI D31 to D0	3	—	ns
MCLKI $\uparrow$ to Data valid hold time	$t_{CHDX}$	MCLKI D31 to D0	1	—	ns
MCLKO $\downarrow$ to WRXn (as byte enable) delay time	$t_{CLWRL}$	MCLKO WRXn	—	9	ns
	$t_{CLWRH}$		- 1	—	ns
MCLKO $\downarrow$ to CSXn delay time	$t_{CLCSL}$	MCLKO CSXn	—	9	ns
	$t_{CLCSH}$		—	8	ns

Note: The usage of the external feedback from MCLKO to MCLKI is not recommended.

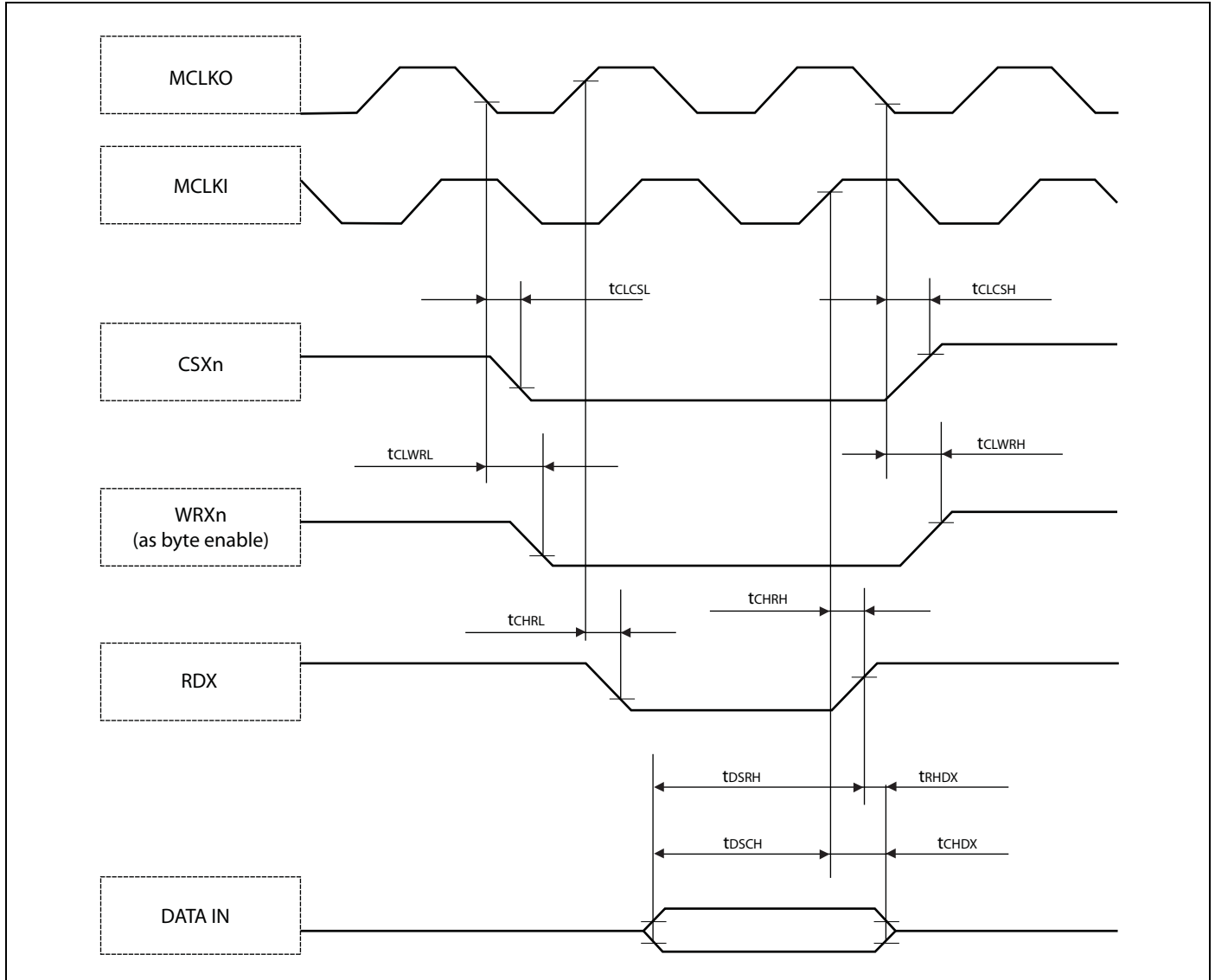

Synchronous/Asynchronous Read Access with Internal MCLKO --> MCLKI Feedback

( $V_{DD35} = 4.5\text{ V to }5.5\text{ V}$ ,  $V_{SS5} = AV_{SS5} = 0\text{ V}$ ,  $T_A = -40^\circ\text{C to }+105^\circ\text{C}$ )

Parameter	Symbol	Pin Name	Value		Unit
			Min	Max	
MCLKO $\uparrow$ to RDX delay time	TCHRL	MCLKO RDX	- 5	2	ns
	TCHRH		- 5	2	ns
Data valid to RDX $\uparrow$ setup time	TDSRH	RDX D31 to D0	20	—	ns
RDX $\uparrow$ to Data valid hold time (internal MCLKO $\rightarrow$ MCLKI / MCLKI feedback)	TRHDX	RDX D31 to D0	0	—	ns
MCLKO $\downarrow$ to WRXn (as byte enable) delay time	TCLWRL	MCLKO WRXn	—	9	ns
	TCLWRH		- 1	—	ns
MCLKO $\downarrow$ to CSXn delay time	TCLCSL	MCLKO CSXn	—	9	ns
	TCLCSH		—	8	ns

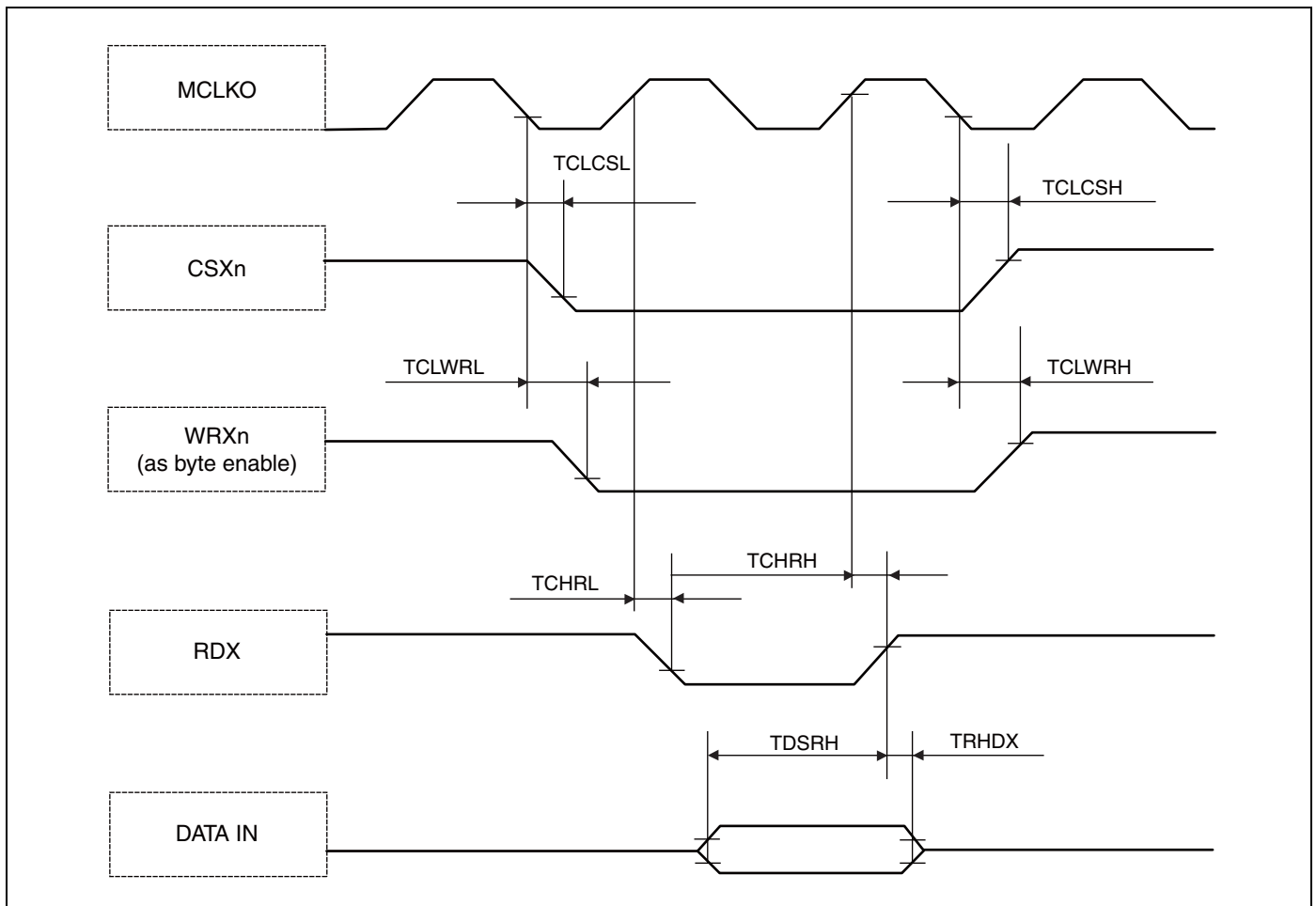

Synchronous Write Access - Byte Control Type

( $V_{DD35} = 4.5\text{ V to }5.5\text{ V}$ ,  $V_{SS5} = AV_{SS5} = 0\text{ V}$ ,  $T_A = -40^\circ\text{C to }+105^\circ\text{C}$ )

Parameter	Symbol	Pin Name	Value		Unit
			Min	Max	
MCLKO ↓ to WEX delay time	TCLWL	MCLKO	—	9	ns
	TCLWH	WEX	2	—	ns
Data valid to WEX ↓ setup time	TDSWL	WEX D31 to D0	- 11	—	ns
WEX ↑ to Data valid hold time	TWHDH	WEX D31 to D0	$t_{CLKT} - 10$	—	ns
MCLKO ↓ to WRXn (as byte enable) delay time	TCLWRL	MCLKO	—	9	ns
	TCLWRH	WRXn	- 1	—	ns
MCLKO ↓ to CSXn delay time	TCLCSL	MCLKO	—	9	ns
	TCLCSH	CSXn	—	8	ns

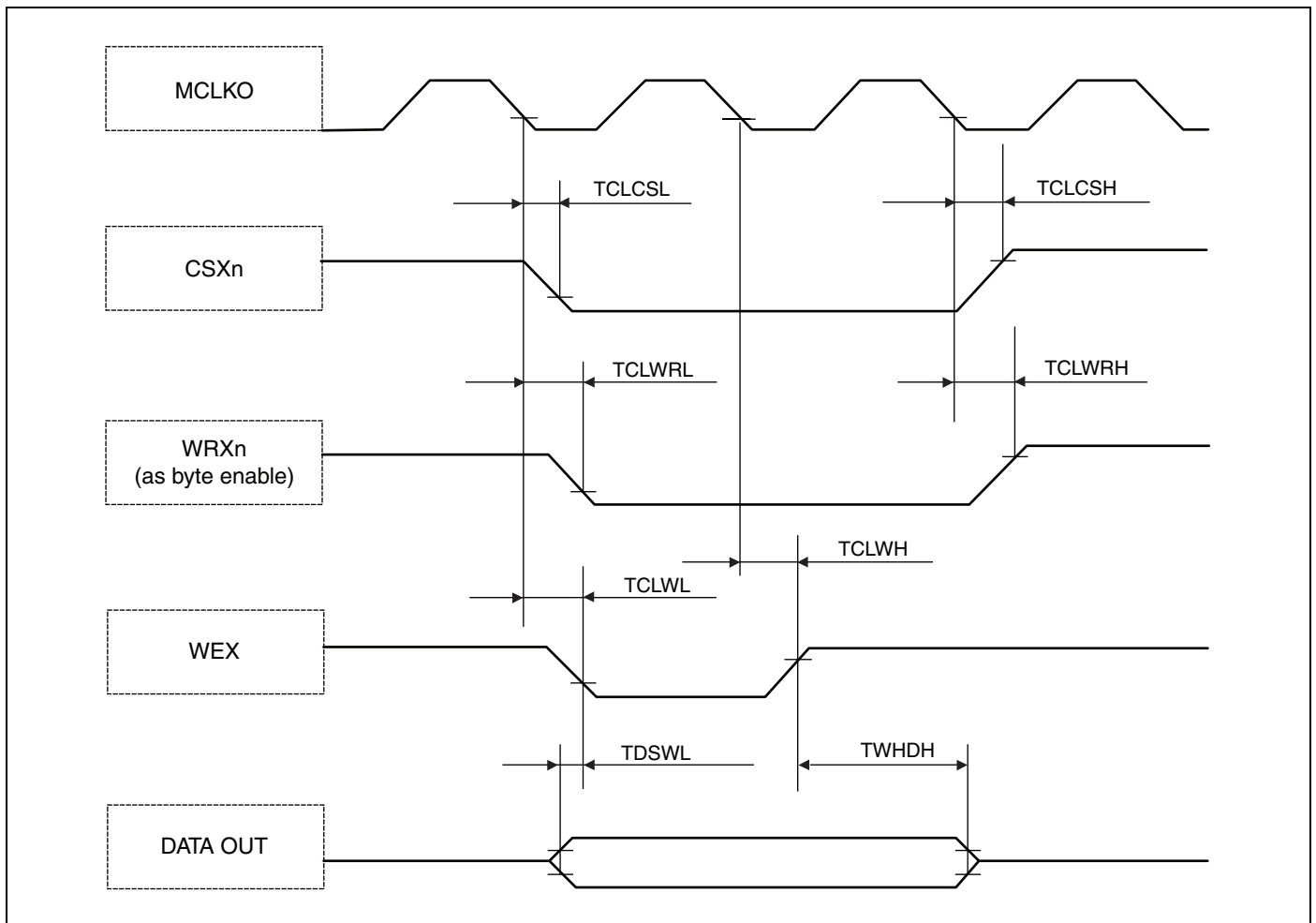

Synchronous Write Access - No Byte Control Type

( $V_{DD35} = 4.5\text{ V to }5.5\text{ V}$ ,  $V_{SS5} = AV_{SS5} = 0\text{ V}$ ,  $T_A = -40^\circ\text{C to }+105^\circ\text{C}$ )

Parameter	Symbol	Pin Name	Value		Unit
			Min	Max	
MCLKO ↓ to WRXn delay time	TCLWRL	MCLKO WRXn	—	9	ns
	TCLWRH		- 1	—	ns
Data valid to WRXn ↓ setup time	TDSWRL	WRXn D31 to D0	- 12	—	ns
WRXn ↑ to Data valid hold time	TWRHDH	WRXn D31 to D0	$t_{CLKT} - 8$	—	ns
MCLKO ↓ to CSXn delay time	TCLCSL	MCLKO CSXn	—	9	ns
	TCLCSH		—	8	ns

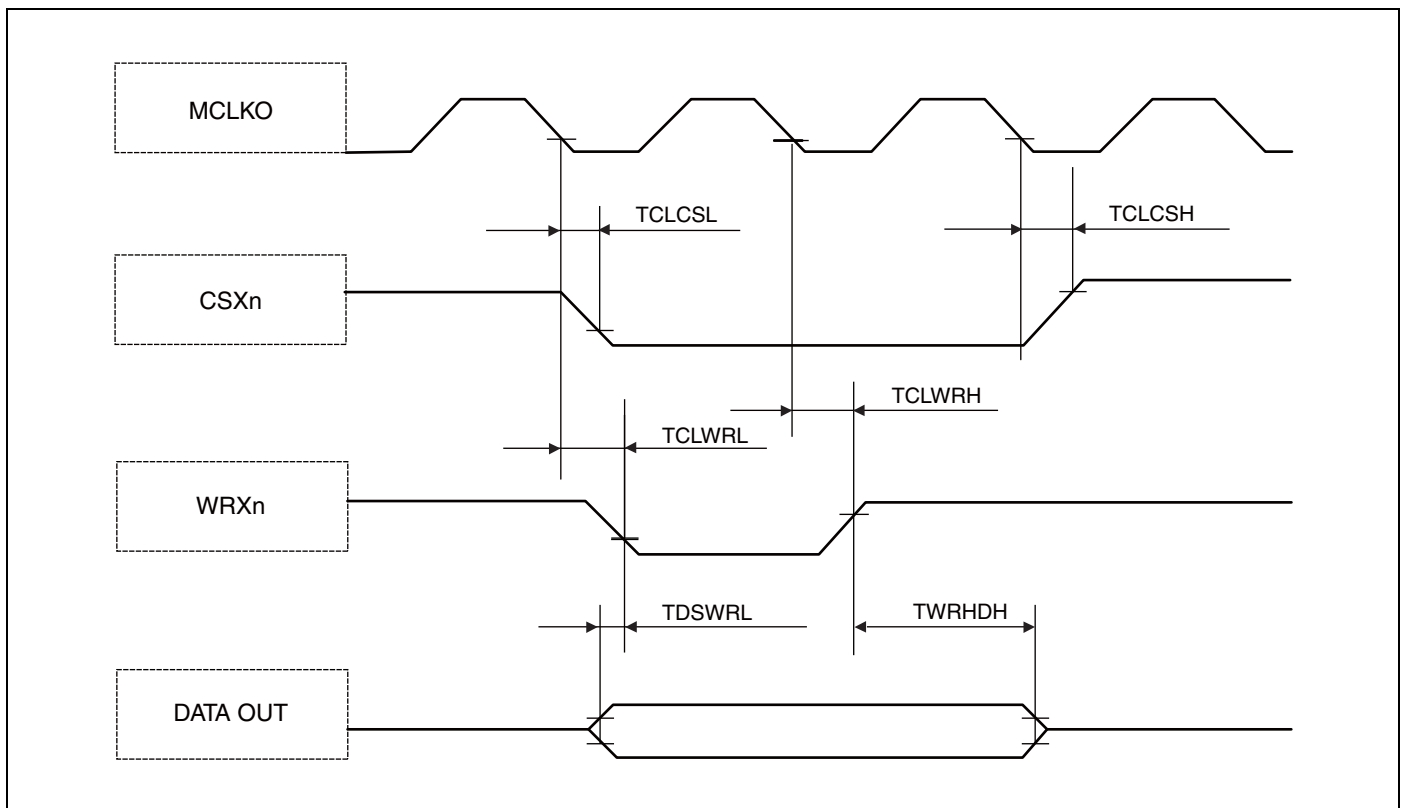

Asynchronous Write Access - Byte Control Type

( $V_{DD35} = 4.5\text{ V to }5.5\text{ V}$ ,  $V_{SS5} = AV_{SS5} = 0\text{ V}$ ,  $T_A = -40^{\circ}\text{C to }+105^{\circ}\text{C}$ )

Parameter	Symbol	Pin Name	Value		Unit
			Min	Max	
WEX ↓ to WEX ↑ pulse width	TWLWH	WEX	$t_{CLKT} - 2$	—	ns
Data valid to WEX ↓ setup time	TDSWL	WEX D31 to D0	$1/2 \times t_{CLKT} - 13$	—	ns
WEX ↑ to Data valid hold time	TWHDH	WEX D31 to D0	$1/2 \times t_{CLKT} - 10$	—	ns
WEX to WRXn delay time	TWRLWL	WEX WRXn	—	$1/2 \times t_{CLKT} + 2$	ns
	TWHWRH	WRXn	$1/2 \times t_{CLKT} - 4$	—	ns
WEX to CSXn delay time	TCLWL	WEX CSXn	—	$1/2 \times t_{CLKT}$	ns
	TWHCH	CSXn	$1/2 \times t_{CLKT} - 5$	—	ns

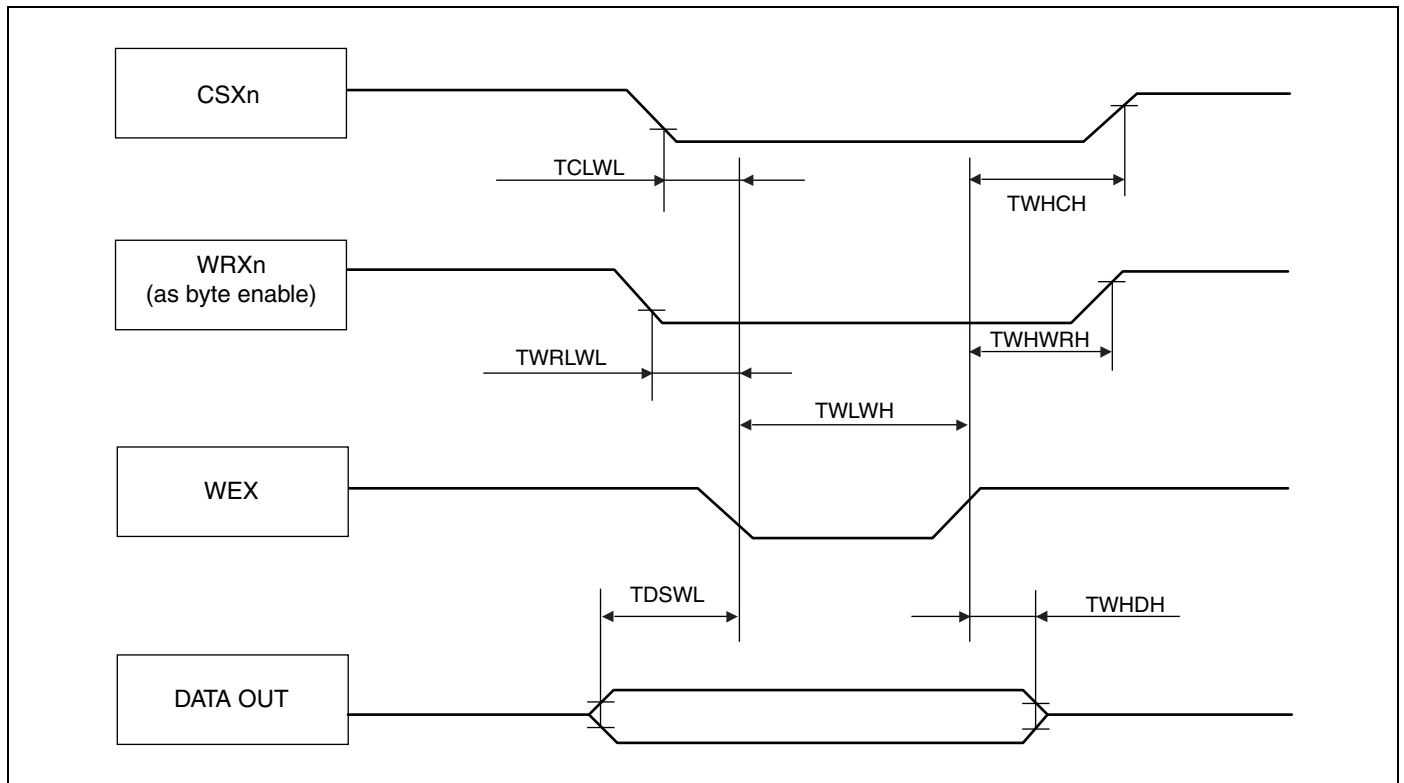

Asynchronous Write Access - No Byte Control Type

( $V_{DD35} = 4.5\text{ V to }5.5\text{ V}$ ,  $V_{SS5} = AV_{SS5} = 0\text{ V}$ ,  $T_A = -40^\circ\text{C to }+105^\circ\text{C}$ )

Parameter	Symbol	Pin Name	Value		Unit
			Min	Max	
WRXn ↓ to WRXn ↑ pulse width	TWRLWRH	WRXn	$t_{CLKT} - 1$	—	ns
Data valid to WRXn ↓ setup time	TDSWRL	WRXn D31 to D0	$1/2 \times t_{CLKT} - 14$	—	ns
WRXn ↑ to Data valid hold time	TWRHCH	WRXn D31 to D0	$1/2 \times t_{CLKT} - 7$	—	ns
WRXn to CSXn delay time	TCLWRL	WRXn CSXn	—	$1/2 \times t_{CLKT} - 1$	ns
	TWRHCH	WRXn CSXn	$1/2 \times t_{CLKT} - 3$	—	ns

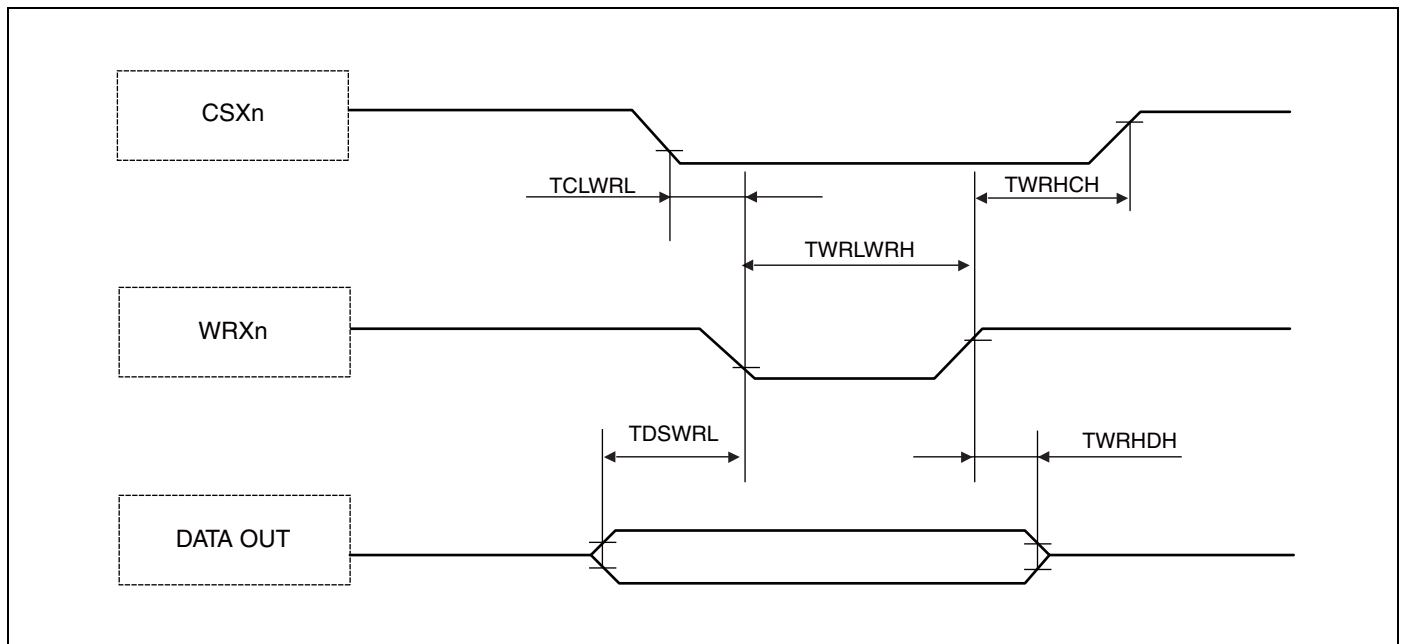



*RDY Waitcycle Insertion*

 ( $V_{DD35} = 4.5\text{ V to }5.5\text{ V}$ ,  $V_{SS5} = AV_{SS5} = 0\text{ V}$ ,  $T_A = -40^\circ\text{C to }+105^\circ\text{C}$ )

Parameter	Symbol	Pin Name	Value		Unit
			Min	Max	
RDY setup time	TRDYS	MCLKO RDY	21	—	ns
RDY hold time	TRDYH	MCLKO RDY	0	—	ns

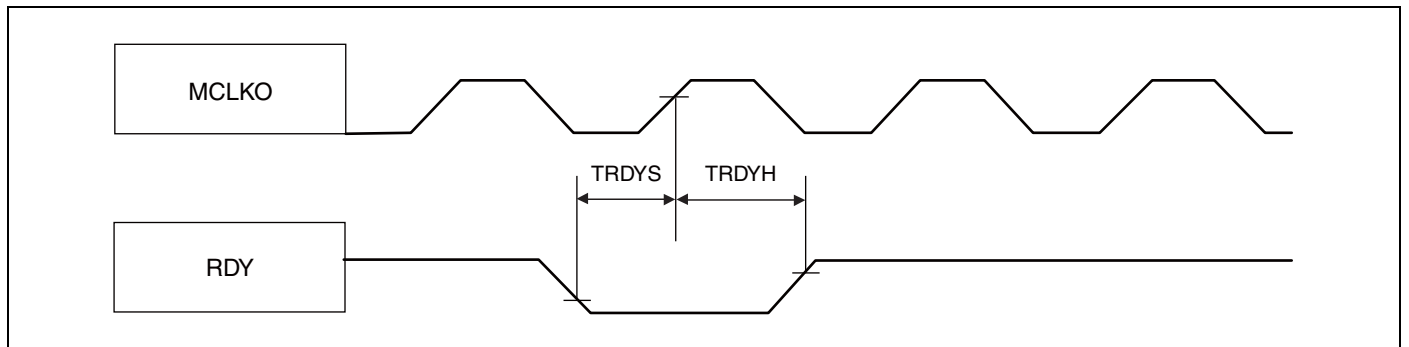

Bus Hold Timing

( $V_{DD35} = 4.5\text{ V to } 5.5\text{ V}$ ,  $V_{SS5} = AV_{SS5} = 0\text{ V}$ ,  $T_A = -40^\circ\text{C to } +105^\circ\text{C}$ )

Parameter	Symbol	Pin Name	Value		Unit
			Min	Max	
MCLKO ↓ to BGRNTX delay time	TCLBGL	MCLKO BGRNTX	—	$2 \times t_{CLKT} + 5$	ns
	TCLBGH		—	$2 \times t_{CLKT} + 2$	ns
Bus HIZ to BGRNTX ↓	TAXBGL	BGRNTX MCLK* A0 to An RDX, ASX WRXn, WEX CSXn, BAAX	$t_{CLKT} - 6$	—	ns
BGRNTX ↑ to Bus drive	TBGHAV		$t_{CLKT} + 8$	—	ns

Note : BRQ must be kept High until the bus is granted (this is acknowledged by the falling edge of BGRNTX).  
 It must be kept High as long as the bus shall be hold.  
 After releasing the bus (BRQ set to Low) this is acknowledged by the rising edge of BGRNTX.

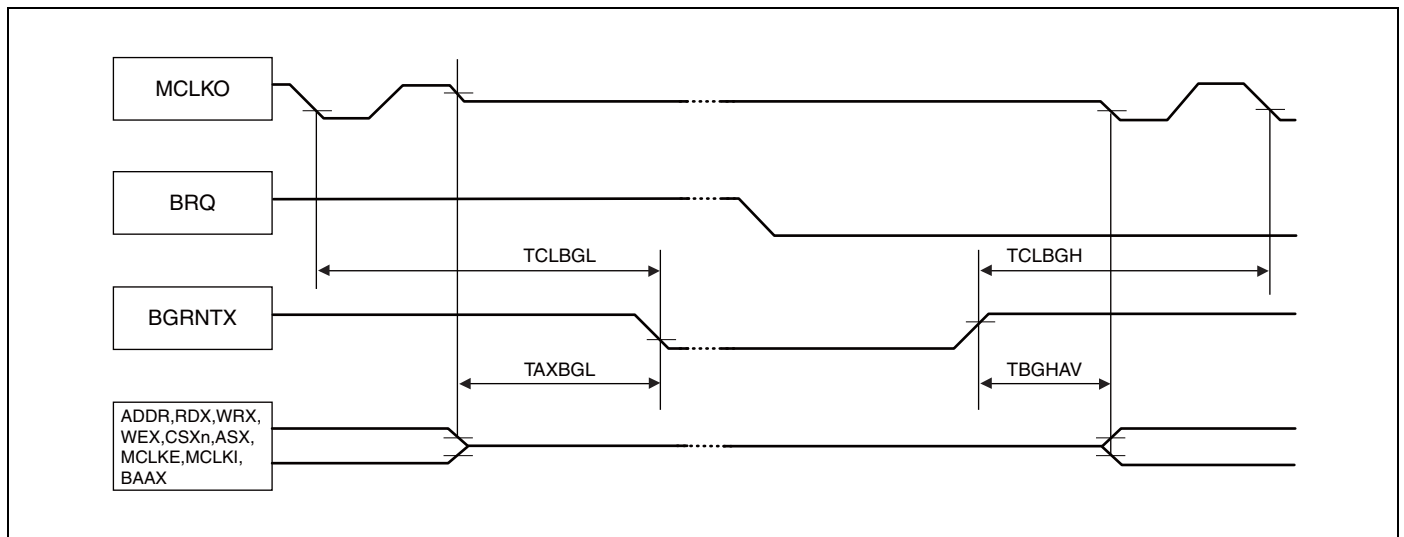

## Clock Relationships

( $V_{DD35} = 4.5\text{ V to }5.5\text{ V}$ ,  $V_{SS5} = AV_{SS5} = 0\text{ V}$ ,  $T_A = -40^\circ\text{C to }+105^\circ\text{C}$ )

Parameter	Symbol	Pin Name	Value		Unit
			Min	Max	
MCLKO ↓ to MCLKE (in sleep mode)	TCLML	MCLKO MCLKE	—	7	ns
	TCLMH		-1	—	ns

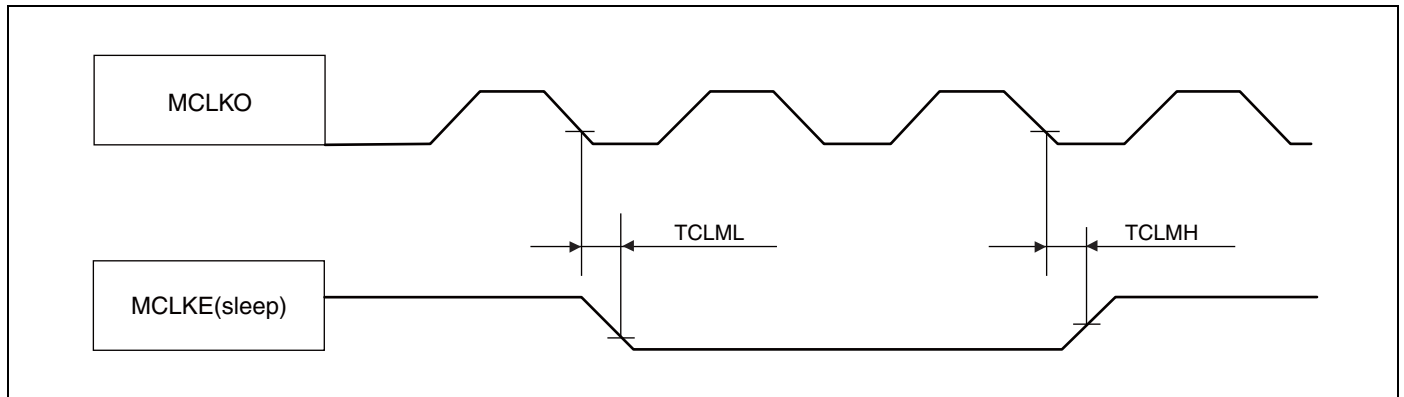

*DMA Transfer*

 (V<sub>DD35</sub> = 4.5 V to 5.5 V, V<sub>SS5</sub> = AV<sub>SS5</sub> = 0 V, T<sub>A</sub> = -40°C to +105°C)

Parameter	Symbol	Pin Name	Value		Unit
			Min	Max	
MCLKO ↓ to DACKX delay time	TCLDAL	MCLKO	—	9	ns
	TCLDAH	DACKXn	—	6	ns
MCLKO ↓ to DEOP delay time	TCLDEL	MCLKO	—	8	ns
	TCLDEH	DEOPn	—	9	ns
MCLKO ↑ to DACKX delay time (ADDR → delayed CS)	TCHDAL	MCLKO DACKXn	- 4	3	ns
MCLKO ↑ to DEOP delay time (ADDR → delayed CS)	TCHDEL	MCLKO DEOPn	- 4	3	ns
DREQ setup time	TDRQS	MCLKO DREQn	23	—	ns
DREQ hold time	TDRQH	MCLKO DREQn	0	—	ns
DEOTXn setup time	TDTXS	MCLKO DEOTXn	24	—	ns
DEOTXn hold time	TDTXH	MCLKO DEOTXn	0	—	ns

Note : DREQ and DEOTX must be applied for at least  $5 \times t_{CLKT}$  to ensure that they are really sampled and evaluated.  
Under best case conditions (DMA not busy) only setup and hold times are required.

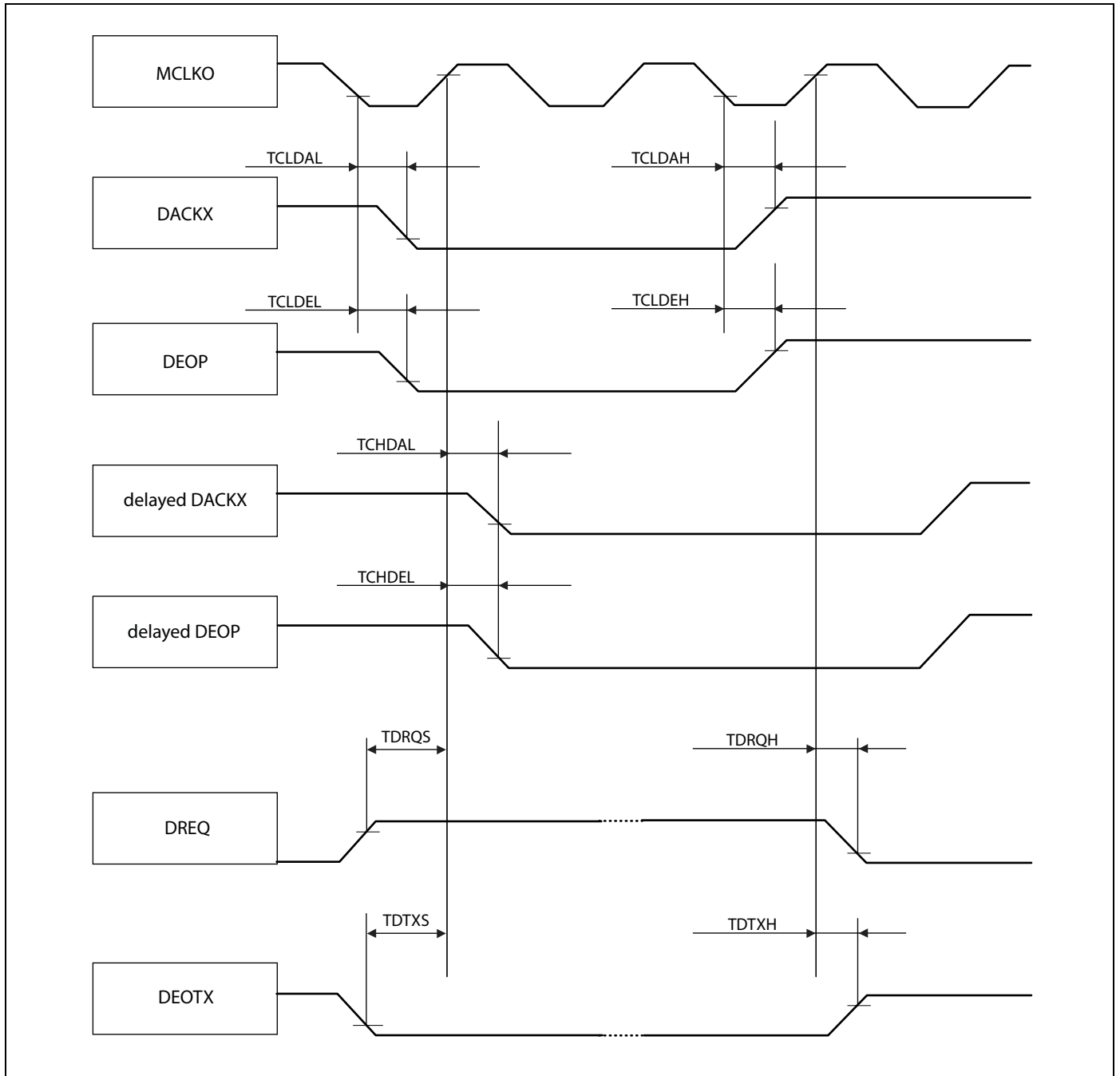

**15.7.8 External Bus AC Timings at  $V_{DD35} = 3.0$  to  $4.5$  V**

- Conditions during AC measurements

All AC tests were measured under the following conditions:

- $I_{Odrive} = 5$  mA
- $V_{DD35} = 3.0$  V to  $4.5$  V,  $I_{load} = 3$  mA
- $V_{SS5} = 0$  V
- $T_a = -40^{\circ}\text{C}$  to  $+105^{\circ}\text{C}$
- $C_l = 50$  pF
- $V_{OL} = 0.2 \times V_{DD35}$
- $V_{OH} = 0.8 \times V_{DD35}$
- $EPILR = 0$ ,  $PILR = 1$  (Automotive Level = worst case)

**Basic Timing**

( $V_{DD35} = 3.0$  V to  $4.5$  V,  $V_{ss5} = AV_{ss5} = 0$  V,  $T_A = -40^{\circ}\text{C}$  to  $+105^{\circ}\text{C}$ )

Parameter	Symbol	Pin Name	Value		Unit
			Min	Max	
MCLKO	TCLCH	MCLKO	$1/2 \times t_{CLKT} - 13$	$1/2 \times t_{CLKT} + 13$	ns
	TCHCL		$1/2 \times t_{CLKT} - 13$	$1/2 \times t_{CLKT} + 13$	ns
MCLKO ↓ to CSXn delay time	TCLCSL	MCLKO CSXn	—	6	ns
	TCLCSH		—	7	ns
MCLKO ↑ to CSXn delay time (Addr → CS delay)	TCHCSL		- 11	0	ns
MCLKO ↓ to ASX delay time	TCLASL	MCLKO	—	6	ns
	TCLASH	ASX	—	9	ns
MCLKO ↓ to BAAX delay time	TCLBAL	MCLKO	—	3	ns
	TCLBAH	BAAX	1	—	ns
MCLKO ↓ to Address valid delay time	TCLAV	MCLKO A25 to A0	—	13	ns

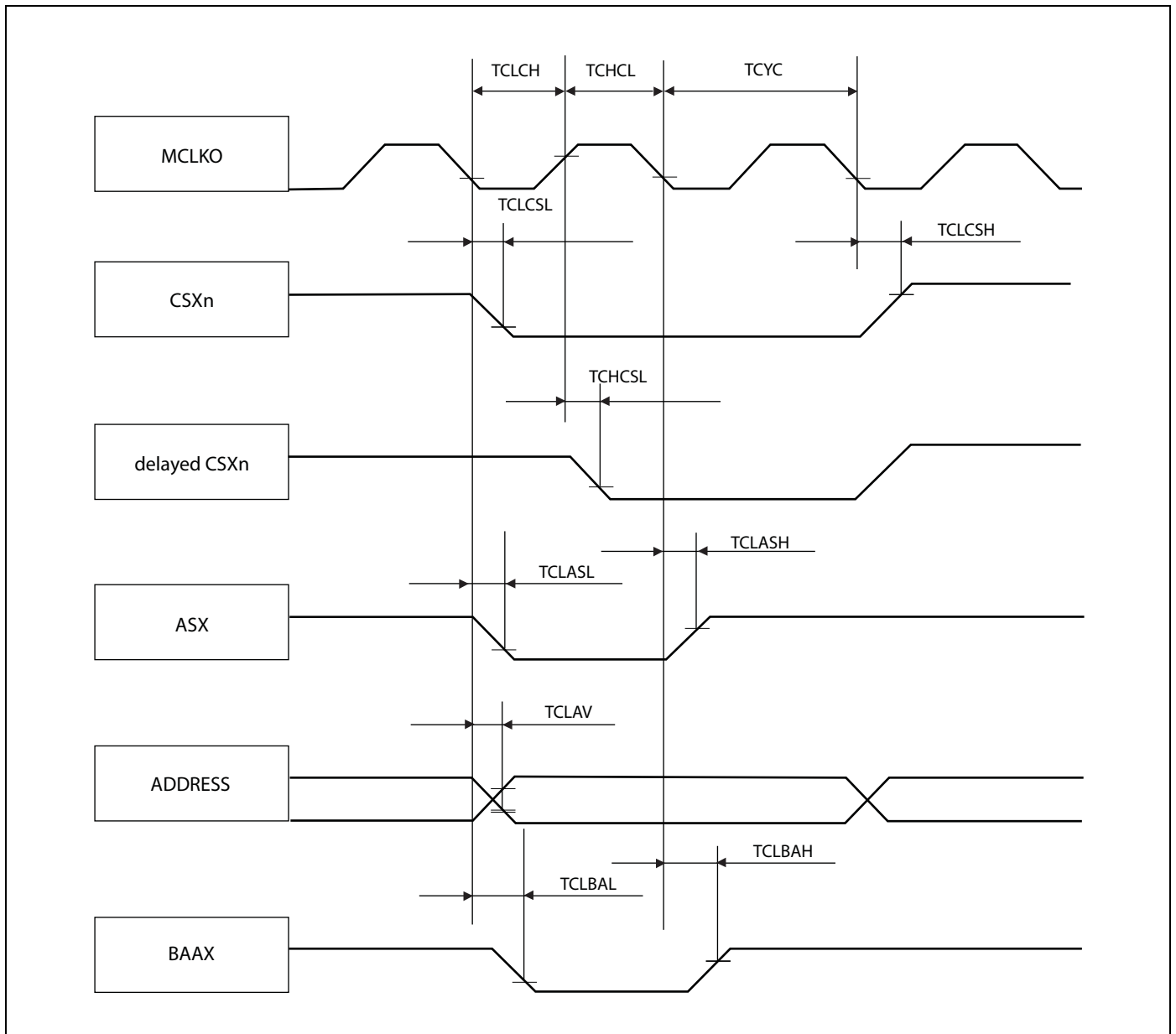

*Synchronous/Asynchronous Read Access With External Mclki Input*
*(V<sub>DD35</sub> = 3.0 V to 4.5 V, V<sub>SS5</sub> = AV<sub>SS5</sub> = 0 V, T<sub>A</sub> = -40°C to +105°C)*

Parameter	Symbol	Pin Name	Value		Unit
			Min	Max	
MCLKO ↑/MCLKI ↑ to RDX delay time	TCHRL	MCLKO RDX	-12	0	ns
	TCHRH	MCLKI RDX	12	26	ns
Data valid to RDX ↑ setup time	TDSRH	RDX D31 to D0	28	—	ns
RDX ↑ to Data valid hold time (external MCLKI input)	TRHDX	RDX D31 to D0	0	—	ns
Data valid to MCLKI ↑ setup time	TDSCH	MCLKI D31 to D0	3	—	ns
MCLKI ↑ to Data valid hold time	TCHDX	MCLKI D31 to D0	1	—	ns
MCLKO ↓ to WRXn (as byte enable) delay time	TCLWRL	MCLKO WRXn	—	6	ns
	TCLWRH		0	—	ns
MCLKO ↓ to CSXn delay time	TCLCSL	MCLKO CSXn	—	6	ns
	TCLCSH		—	7	ns

Note: The usage of the external feedback from MCLKO to MCLKI is not recommended.



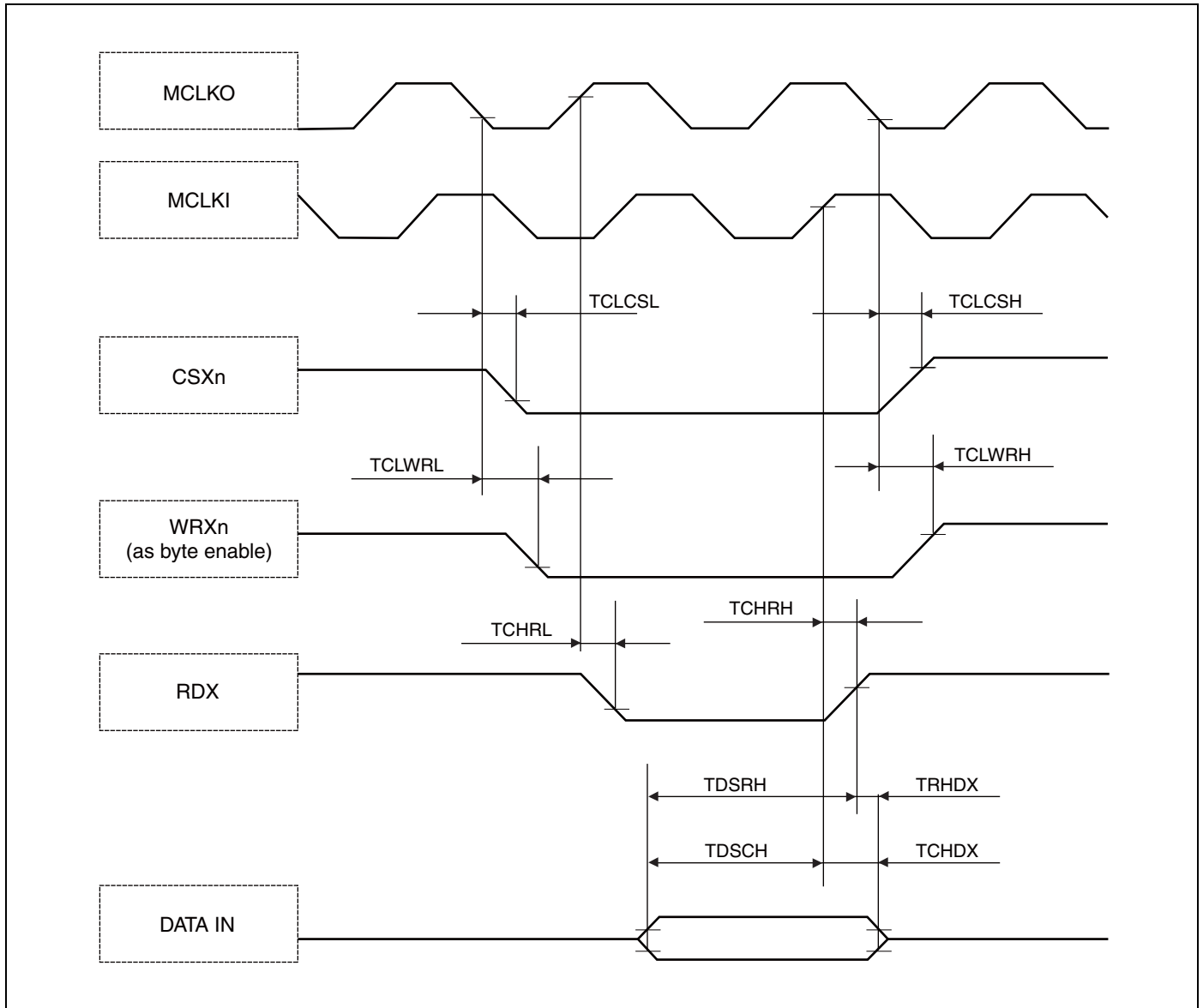

Synchronous/Asynchronous Read Access with Internal MCLKO --> MCLKI Feedback

( $V_{DD35} = 3.0\text{ V to }4.5\text{ V}$ ,  $V_{SS5} = AV_{SS5} = 0\text{ V}$ ,  $T_A = -40^\circ\text{C to }+105^\circ\text{C}$ )

Parameter	Symbol	Pin Name	Value		Unit
			Min	Max	
MCLKO $\uparrow$ to RDX delay time	TCHRL	MCLKO RDX	- 12	0	ns
	TCHRH		- 9	1	ns
Data valid to RDX $\uparrow$ setup time	TDSRH	RDX D31 to D0	29	—	ns
RDX $\uparrow$ to Data valid hold time (internal MCLKO $\rightarrow$ MCLKI / MCLKI feedback)	TRHDX	RDX D31 to D0	0	—	ns
MCLKO $\downarrow$ to WRXn (as byte enable) delay time	TCLWRL	MCLKO WRXn	—	6	ns
	TCLWRH		0	—	ns
MCLKO $\downarrow$ to CSXn delay time	TCLCSL	MCLKO CSXn	—	6	ns
	TCLCSH		—	7	ns

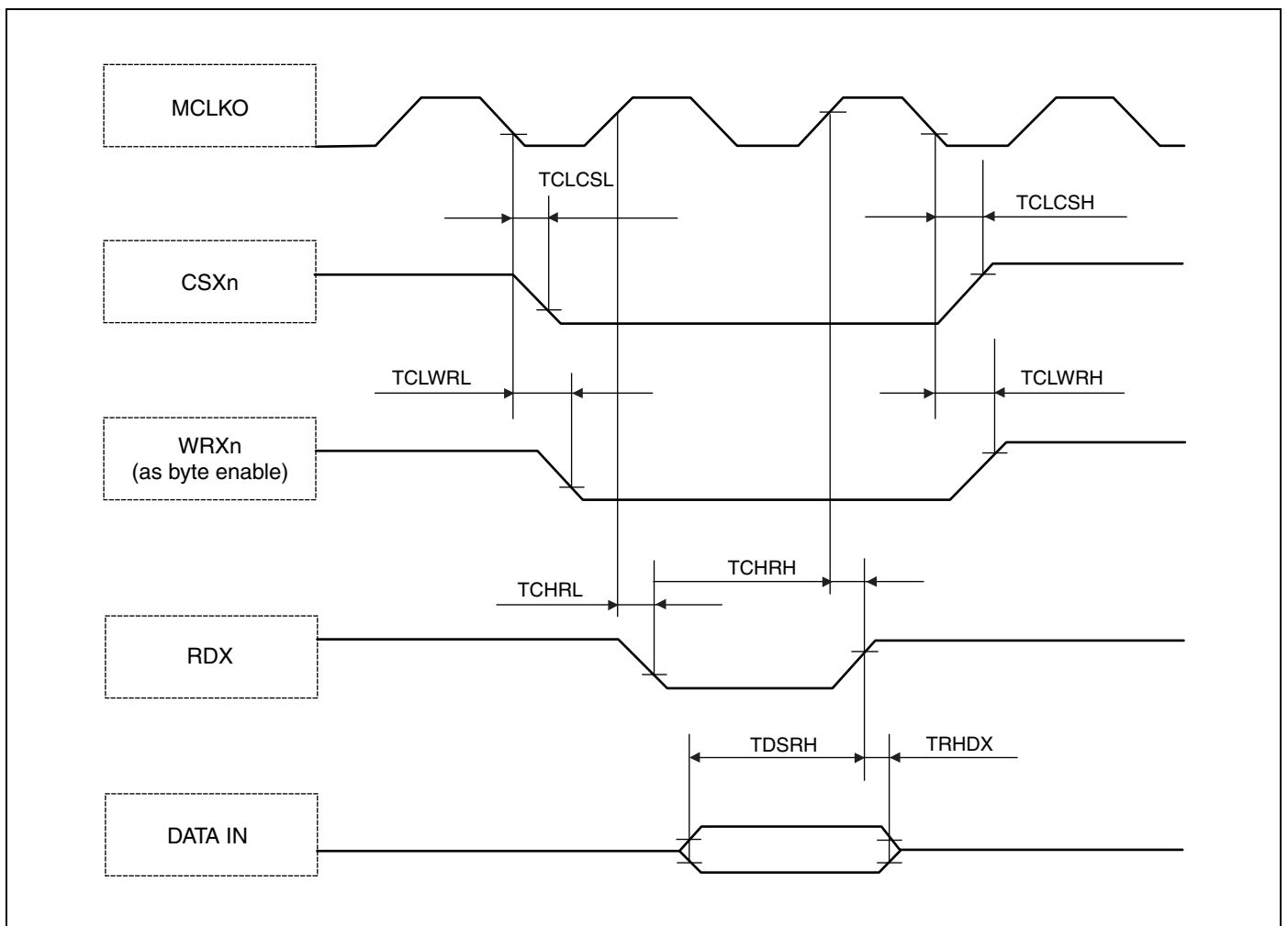

Synchronous Write Access - Byte Control Type

( $V_{DD35} = 3.0\text{ V to }4.5\text{ V}$ ,  $V_{SS5} = AV_{SS5} = 0\text{ V}$ ,  $T_A = -40^\circ\text{C to }+105^\circ\text{C}$ )

Parameter	Symbol	Pin Name	Value		Unit
			Min	Max	
MCLKO ↓ to WEX delay time	TCLWL	MCLKO	—	7	ns
	TCLWH	WEX	1	—	ns
Data valid to WEX ↓ setup time	TDSWL	WEX D31 to D0	-20	—	ns
WEX ↑ to Data valid hold time	TWHDH	WEX D31 to D0	$t_{CLKT} - 19$	—	ns
MCLKO ↓ to WRXn (as byte enable) delay time	TCLWRL	MCLKO	—	6	ns
	TCLWRH	WRXn	0	—	ns
MCLKO ↓ to CSXn delay time	TCLCSL	MCLKO	—	6	ns
	TCLCSH	CSXn	—	7	ns

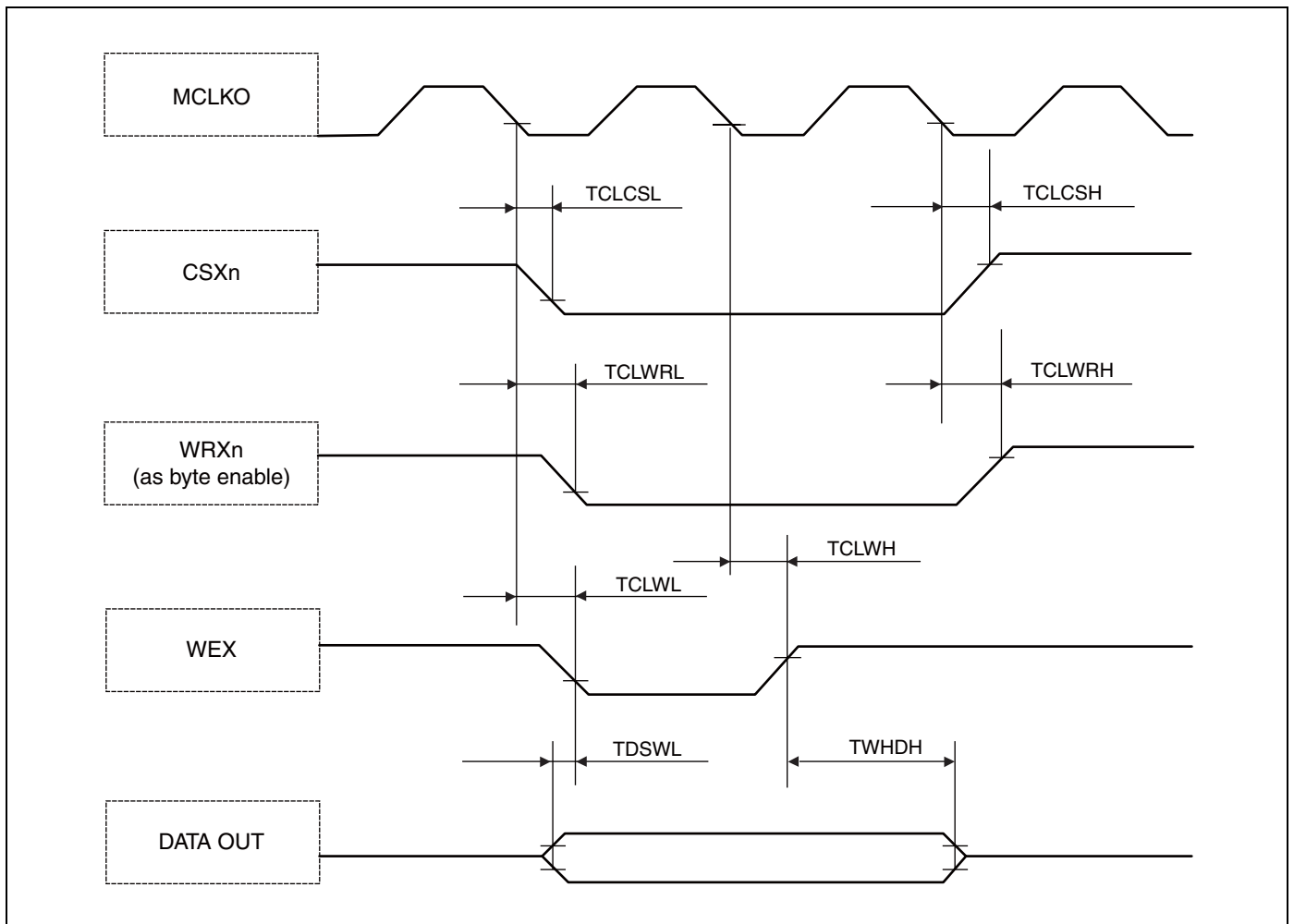

Synchronous Write Access - No Byte Control Type

( $V_{DD35} = 3.0\text{ V to }4.5\text{ V}$ ,  $V_{SS5} = AV_{SS5} = 0\text{ V}$ ,  $T_A = -40^\circ\text{C to }+105^\circ\text{C}$ )

Parameter	Symbol	Pin Name	Value		Unit
			Min	Max	
MCLKO ↓ to WRXn delay time	TCLWRL	MCLKO	—	6	ns
	TCLWRH	WRXn	0	—	ns
Data valid to WRXn ↓ setup time	TDSWRL	WRXn D31 to D0	- 20	—	ns
WRXn ↑ to Data valid hold time	TWRHDH	WRXn D31 to D0	$t_{CLKT} - 14$	—	ns
MCLKO ↓ to CSXn delay time	TCLCSL	MCLKO	—	6	ns
	TCLCSH	CSXn	—	7	ns

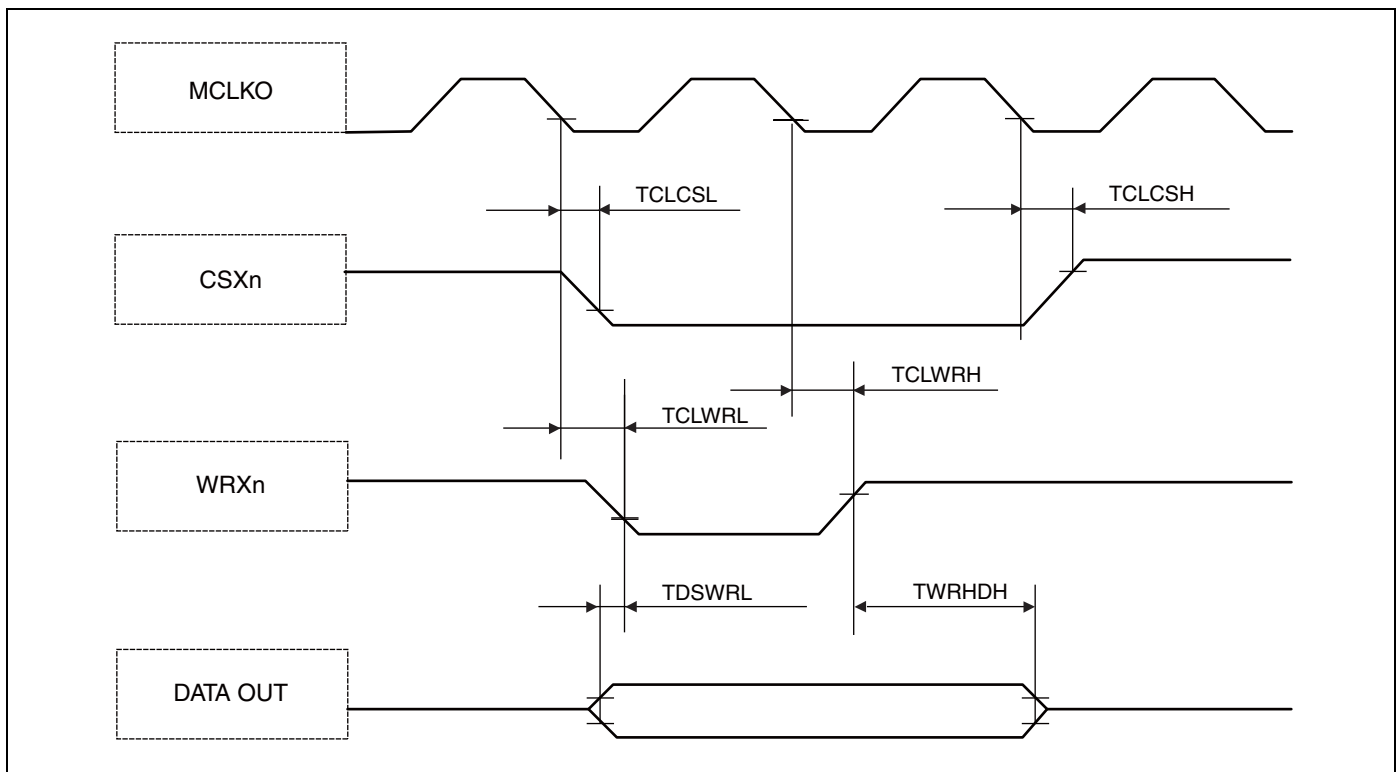

Asynchronous Write Access - Byte Control Type

( $V_{DD35} = 3.0\text{ V to }4.5\text{ V}$ ,  $V_{SS5} = AV_{SS5} = 0\text{ V}$ ,  $T_A = -40^\circ\text{C to }+105^\circ\text{C}$ )

Parameter	Symbol	Pin Name	Value		Unit
			Min	Max	
WEX ↓ to WEX ↑ pulse width	TWLWH	WEX	$t_{CLKT} - 2$	—	ns
Data valid to WEX ↓ setup time	TDSWL	WEX D31 to D0	$1/2 \times t_{CLKT} - 20$	—	ns
WEX ↑ to Data valid hold time	TWHDH	WEX D31 to D0	$1/2 \times t_{CLKT} - 20$	—	ns
WEX to WRXn delay time	TWRLWL	WEX WRXn	—	$1/2 \times t_{CLKT} + 3$	ns
	TWHWRH		$1/2 \times t_{CLKT} - 7$	—	ns
WEX to CSXn delay time	TCLWL	WEX CSXn	—	$1/2 \times t_{CLKT} - 1$	ns
	TWHCH		$1/2 \times t_{CLKT} - 4$	—	ns

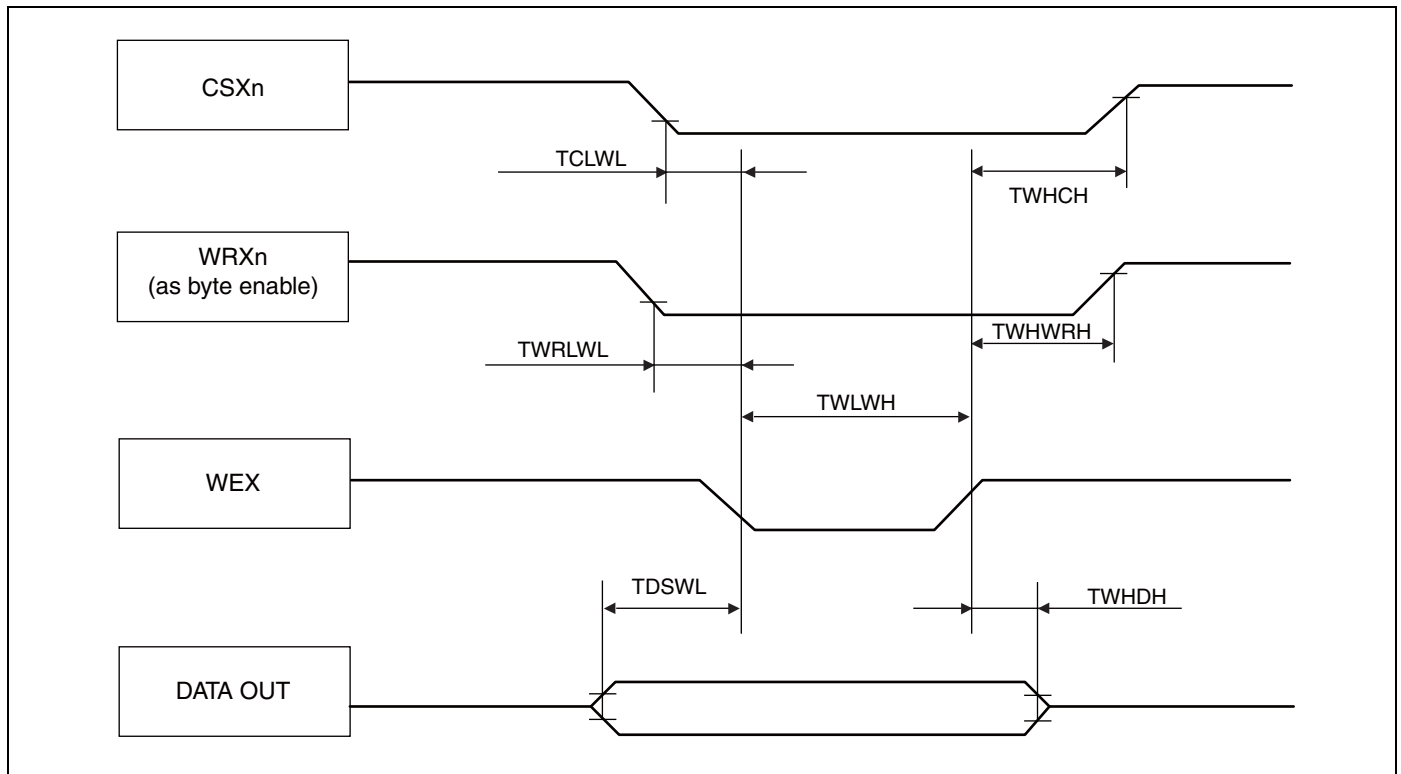

Asynchronous Write Access - No Byte Control Type

( $V_{DD35} = 3.0\text{ V to }4.5\text{ V}$ ,  $V_{SS5} = AV_{SS5} = 0\text{ V}$ ,  $T_A = -40^{\circ}\text{C to }+105^{\circ}\text{C}$ )

Parameter	Symbol	Pin Name	Value		Unit
			Min	Max	
WRXn ↓ to WRXn ↑ pulse width	TWRLWRH	WRXn	$t_{CLKT} - 2$	—	ns
Data valid to WRXn ↓ setup time	TDSWRL	WRXn D31 to D0	$1/2 \times t_{CLKT} - 21$	—	ns
WRXn ↑ to Data valid hold time	TWRHDH	WRXn D31 to D0	$1/2 \times t_{CLKT} - 18$	—	ns
WRXn to CSXn delay time	TCLWRL	WRXn CSXn	—	$1/2 \times t_{CLKT} - 1$	ns
	TWRHCH	WRXn CSXn	$1/2 \times t_{CLKT} - 4$	—	ns

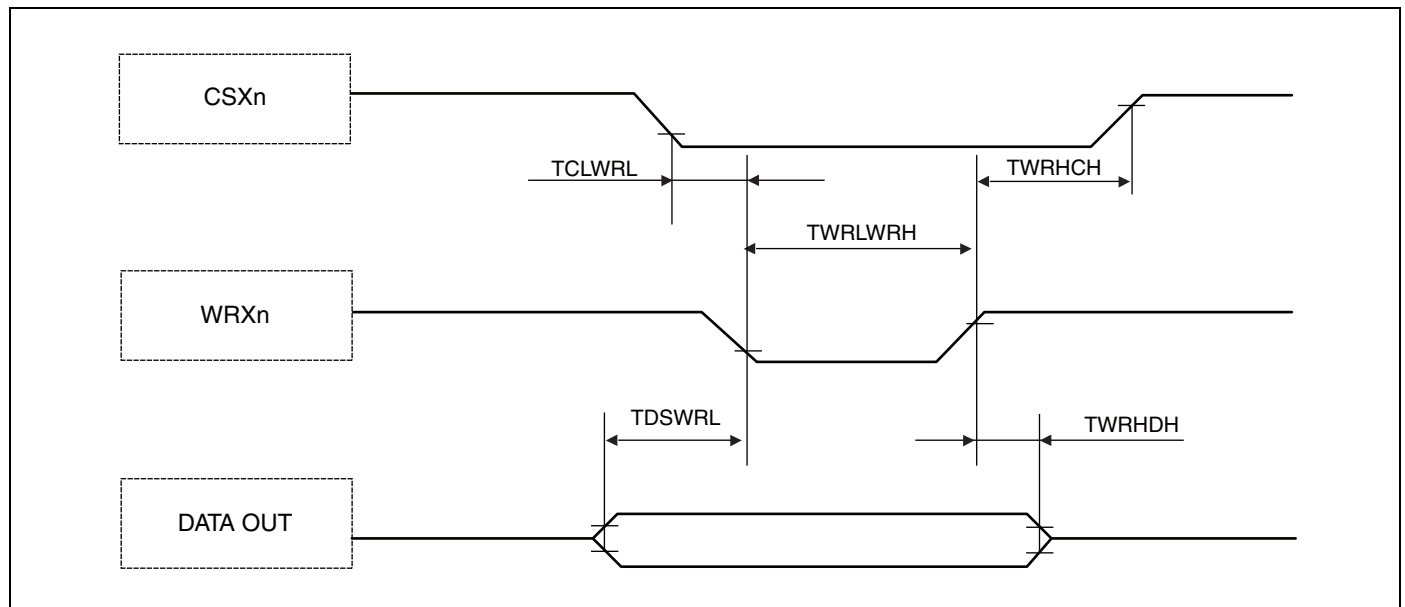

## RDY Waitcycle Insertion

( $V_{DD35} = 3.0\text{ V to }4.5\text{ V}$ ,  $V_{SS5} = AV_{SS5} = 0\text{ V}$ ,  $T_A = -40^\circ\text{C to }+105^\circ\text{C}$ )

Parameter	Symbol	Pin Name	Value		Unit
			Min	Max	
RDY setup time	TRDYS	MCLKO RDY	37	—	ns
RDY hold time	TRDYH	MCLKO RDY	0	—	ns

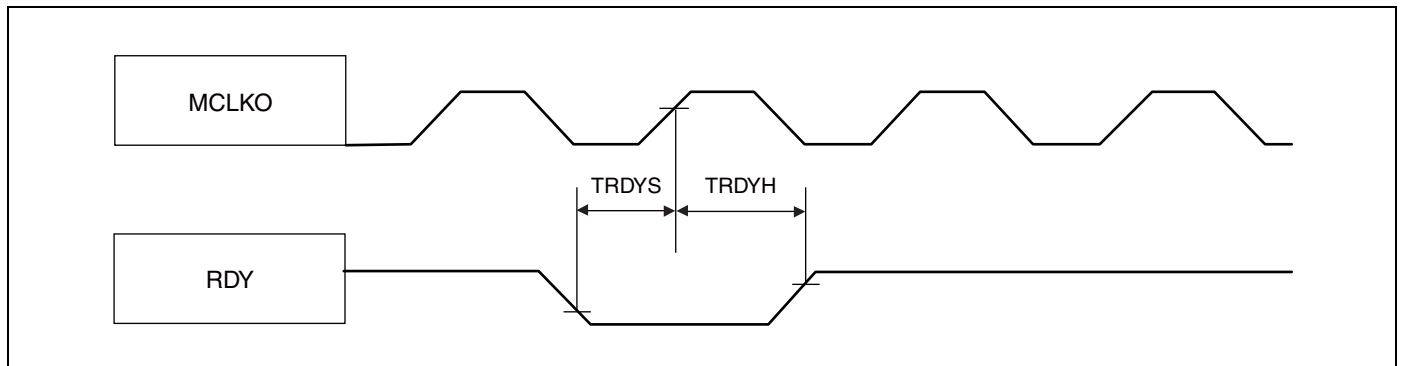

Bus Hold Timing

( $V_{DD35} = 3.0\text{ V to }4.5\text{ V}$ ,  $V_{SS5} = AV_{SS5} = 0\text{ V}$ ,  $T_A = -40^{\circ}\text{C to }+105^{\circ}\text{C}$ )

Parameter	Symbol	Pin Name	Value		Unit
			Min	Max	
MCLKO ↓ to BGRNTX delay time	TCLBGL	MCLKO BGRNTX	—	$2 \times t_{CLKT} + 16$	ns
	TCLBGH		—	$2 \times t_{CLKT} + 3$	ns
Bus HIZ to BGRNTX ↓	TAXBGL	BGRNTX MCLK* A0 to An RDX, ASX WRXn, WEX CSXn, BAAX	$t_{CLKT} + 1$	—	ns
BGRNTX ↑ to Bus drive	TBGHAV		$t_{CLKT} + 1$	—	ns

Note : BRQ must be kept High until the bus is granted (this is acknowledged by the falling edge of BGRNTX).  
 It must be kept High as long as the bus shall be hold.  
 After releasing the bus (BRQ set to Low) this is acknowledged by the rising edge of BGRNTX.

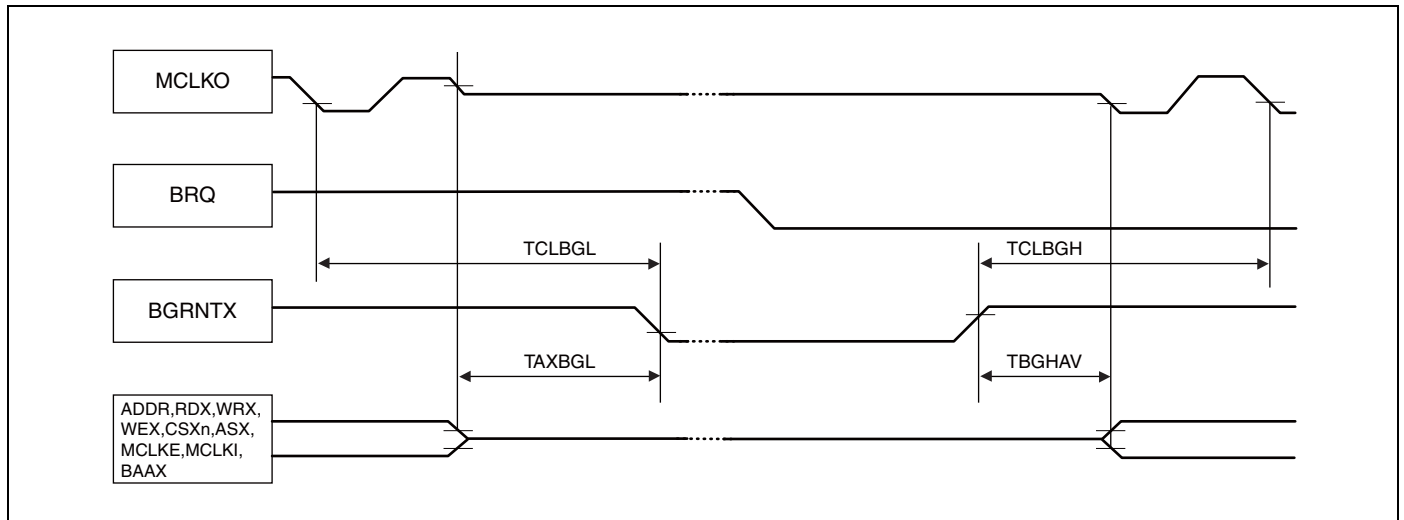



Clock Relationships

( $V_{DD35} = 3.0\text{ V to }4.5\text{ V}$ ,  $V_{SS5} = AV_{SS5} = 0\text{ V}$ ,  $T_A = -40^\circ\text{C to }+105^\circ\text{C}$ )

Parameter	Symbol	Pin Name	Value		Unit
			Min	Max	
MCLKO ↓ to MCLKE (in sleep mode)	TCLML	MCLKO MCLKE	—	3	ns
	TCLMH		0	—	ns

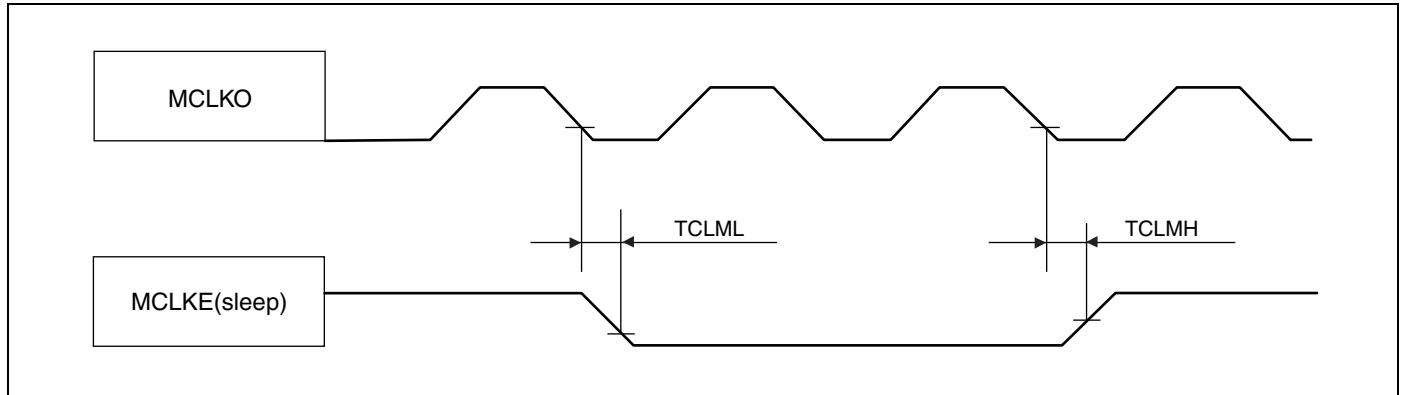

*DMA Transfer*

 (V<sub>DD35</sub> = 3.0 V to 4.5 V, V<sub>SS5</sub> = AV<sub>SS5</sub> = 0 V, T<sub>A</sub> = -40°C to +105°C)

Parameter	Symbol	Pin Name	Value		Unit
			Min	Max	
MCLKO ↓ to DACKX delay time	TCLDAL	MCLKO DACKXn	—	7	ns
	TCLDAH		—	8	ns
MCLKO ↓ to DEOP delay time	TCLDEL	MCLKO DEOPn	—	7	ns
	TCLDEH		—	11	ns
MCLKO ↑ to DACKX delay time (ADDR → delayed CS)	TCHDAL	MCLKO DACKXn	- 10	2	ns
MCLKO ↑ to DEOP delay time (ADDR → delayed CS)	TCHDEL	MCLKO DEOPn	- 10	1	ns
DREQ setup time	TDRQS	MCLKO DREQn	38	—	ns
DREQ hold time	TDRQH	MCLKO DREQn	0	—	ns
DEOTXn setup time	TDTXS	MCLKO DEOTXn	39	—	ns
DEOTXn hold time	TDTXH	MCLKO DEOTXn	0	—	ns

Note : DREQ and DEOTX must be applied for at least  $5 \times t_{CLKT}$  to ensure that they are really sampled and evaluated.  
Under best case conditions (DMA not busy) only setup and hold times are required.

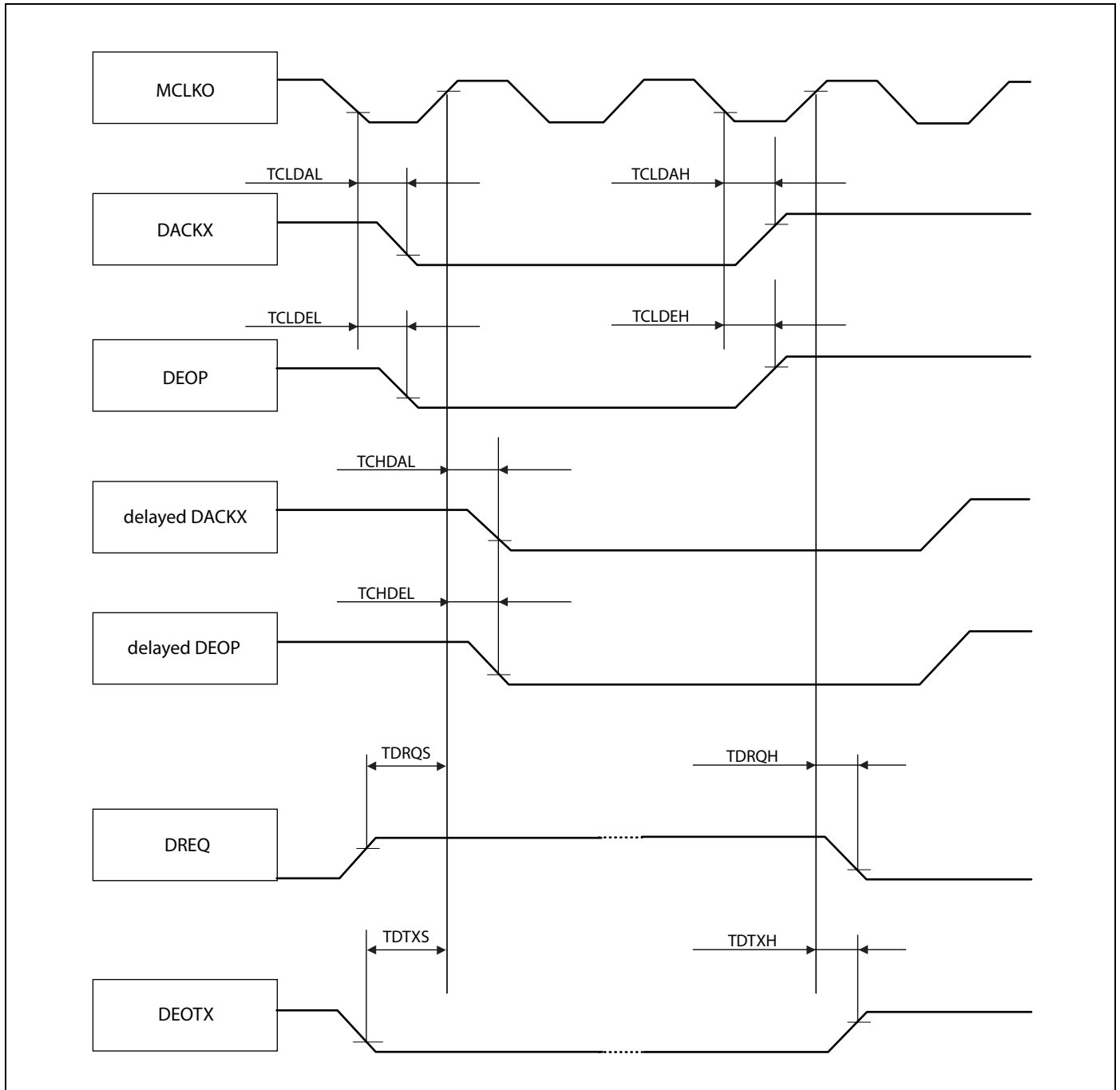

**16. Ordering Information**

Part Number	Package	Remarks
CY91F467DAPFVS-GS-UJE2	208-pin plastic QFP (HQB208)	
CY91F467DBPFVS-GS-UJE2		
CY91F467DAPVSR-GS-UJE2		
CY91F467DBPVSR-GS-UJE2		

### 17. Package Dimension

Package Type	Package Code
QFP 208-pin	HQB208

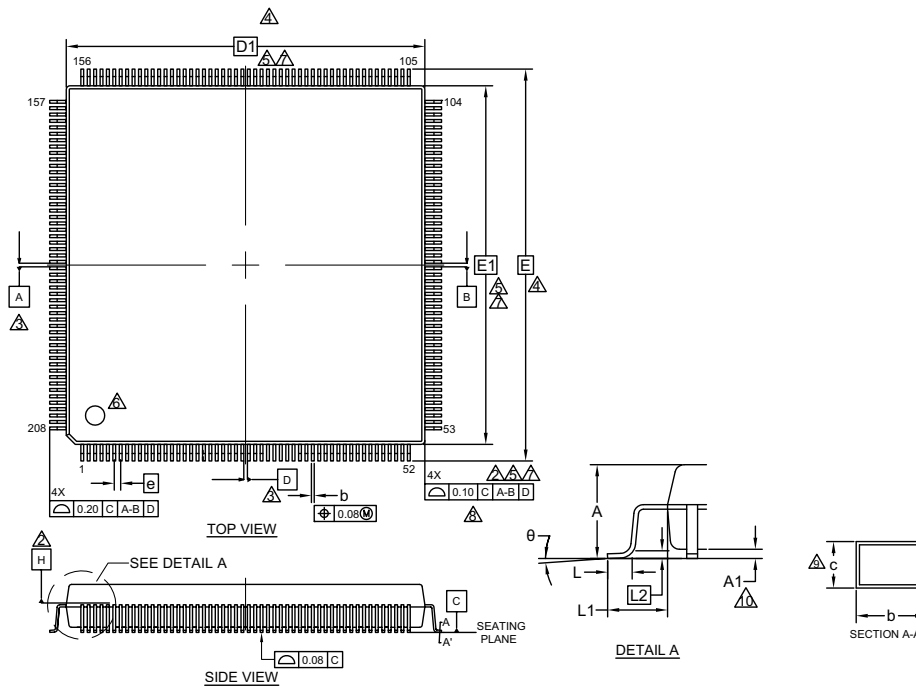

SYMBOL	DIMENSIONS		
	MIN.	NOM.	MAX.
A	—	—	3.95
A1	0.25	—	0.50
b	0.17	0.22	0.27
c	0.09	—	0.20
D	30.60 BSC		
D1	28.00 BSC		
e	0.50 BSC		
E	30.60 BSC		
E1	28.00 BSC		
θ	0°	—	8°
L	0.45	0.60	0.75
L1	1.30 REF		
L2	0.25 BSC		

**NOTES**

- ALL DIMENSIONS ARE IN MILLIMETERS.
- DATUM PLANE H IS LOCATED AT THE BOTTOM OF THE MOLD PARTING LINE COINCIDENT WITH WHERE THE LEAD EXITS THE BODY.
- DATUMS A-B AND D TO BE DETERMINED AT DATUM PLANE H.
- TO BE DETERMINED AT SEATING PLANE C.
- DIMENSIONS D1 AND E1 DO NOT INCLUDE MOLD PROTRUSION. ALLOWABLE PROTRUSION IS 0.25mm PRE SIDE. DIMENSIONS D1 AND E1 INCLUDE MOLD MISMATCH AND ARE DETERMINED AT DATUM PLANE H.
- DETAILS OF PIN 1 IDENTIFIER ARE OPTIONAL BUT MUST BE LOCATED WITHIN THE ZONE INDICATED.
- REGARDLESS OF THE RELATIVE SIZE OF THE UPPER AND LOWER BODY SECTIONS. DIMENSIONS D1 AND E1 ARE DETERMINED AT THE LARGEST FEATURE OF THE BODY EXCLUSIVE OF MOLD FLASH AND GATE BURRS. BUT INCLUDING ANY MISMATCH BETWEEN THE UPPER AND LOWER SECTIONS OF THE MOLDER BODY.
- DIMENSION b DOES NOT INCLUDE DAMBAR PROTRUSION. THE DAMBAR PROTRUSION (⊗) SHALL NOT CAUSE THE LEAD WIDTH TO EXCEED b MAXIMUM BY MORE THAN 0.08mm. DAMBAR CANNOT BE LOCATED ON THE LOWER RADIUS OR THE LEAD FOOT.
- THESE DIMENSIONS APPLY TO THE FLAT SECTION OF THE LEAD BETWEEN 0.10mm AND 0.25mm FROM THE LEAD TIP.
- A1 IS DEFINED AS THE DISTANCE FROM THE SEATING PLANE TO THE LOWEST POINT OF THE PACKAGE BODY.

PACKAGE OUTLINE, 208 LEAD QFP, 28.00X28.00X3.95 MM HQB208 REV. \*

002-18454 \*\*

## 18. Revision History

Spanion Publication Number: DS07-16612-2E

Version	Date	Remark
2.0	2007-09-04	Initial version
2.1	2007-10-08	Revision history table added Fixed PDF generation problem before section "AD converter characteristics" Absolute maximum ratings: Smoothing capacitor size at VCC18C changed to "typ 4.7uF" Output voltage 2 is max. $V_{DD35}$ Recommended operating conditions: Power supply slew rate fixed Exchanged the sequence of device names into "MB91F465DA, MB91F467DA" where they appear on one line
2.2	2007-10-16	Moved revision history to the end of file Features: Added Clock Monitor Corrected VCC18C pin number in table "Power supply/Ground pins" pg.14 Electrical characteristics: Added section 7.FLASH memory program/erase characteristics
2.3	2007-10-22	DC characterisitcs: Corrected $I_{CC-H}$ in STOP + RTC 100kHz mode and $I_{LV}$ (lcc of low volt detection) max. value
2.4	2007-10-25	FLASH memory program/erase characteristics: Typo fixed in note *1 Recommended operating conditions: Corrected text for smoothing capacitor at VCC18C pin Naming inconsistency AVSS / AVSS5 fixed Features: added Up/Down counter Product lineup: fixed number of interrupt channels Handling devices: changed the notes about external clock supply and removed section "Single phase clock supply" Clock timing: removed "Single phase clock supply" from freq. table
2.5	2008-1-11	DC characterisitcs: $I_{LL} = +/- 3 \mu A$ at 105 deg.C IO CIRCUIT TYPE: Corrected oscillator pin block diagrams ELECTRICAL CHARACTERISTICS: re-arranged section sequence Fixed typos in ALARM comparator spec. Added MB91F467DB (called F467Dx if the text item is for bot revisions) Corrected IO-MAP according to latest proofread on F460G series Various corrections after proofread by FJ
2.6	2008-02-04	Added MEMO and DISCLAIMER
2.7	2008-02-18	AC-Characteristics: Replaced "rising"/"falling" with arrow-up/arrow-down

Version	Date	Remark
2.8	2008-06-20	<p>Corrected missing bullets on PDF pages 2+3            Pin Assignment, Block Diagram:            Corrected naming and assignments of TTG inputs, SGO and DACKX0            Notes on PS register: Re-formatted for better understanding            ADC Characteristics: Offset between ADC channels is max. 4 LSB            DC Characteristics: Added <math>I_{LVI}</math> (<math>I_{CC}</math> of internal low voltage detection), renamed <math>I_{LV}</math> into <math>I_{LVE}</math> (for external low voltage detection)            AC Characteristics for external bus: Added notes that the usage of external feedback MCLKO --&gt; MCLKI is not recommended.            Flash parallel programming mode:            Added notes about the pins to be set fix-0 / fix-1 (MD_2:0,...)            Added section about the wait times after power on            Flash operation modes:            Added note about the BootROM fuction entry address for operation mode switch.            Package Dimension: Updated package drawing            All pages: Corrected typos and formatting bugs found by FJ proofread</p>
2.9	2008-06-30	EMBEDDED PROGRAM/DATA MEMORY (FLASH): Corrected "The operation mode of the flash memory ..." instead of "of the MCU"
2.10	2008-08-04	<p>Resources,Product lineup: Added Supply Supervisor (Low voltage detection)            DC Characteristics: Updated pull-up/pull-down resistance values, updated and re-numbered the table footnotes</p>
2.11	2008-08-18	<p>Interrupt Vector Table: corrected the footnotes            Flash Security: Corrected the sector assignments of FSV1/FSV2 bits            Electrical Characteristics: removed the note that analog input/output pins cannot accept +B signal input.            Ordering information: updated the part numbers            All pages: Kilobytes are now written with "K"</p>

**NOTE: Please see "Document History" about later revised information.**

### 19. Major Changes

Page	Section	Change Results																								
Rev.*B																										
-		Marketing Part Numbers changed from an MB prefix to a CY prefix for all of these products.																								
P7,P132 ,P133	2. Pin Assignment 16. Ordering Information 17. Package Dimension	Package description modified to JEDEC description. FPT-208P-M04 → (HQB208)																								
P132	16. Ordering Information	<p>Revised Marketing Part Numbers as follows:</p> <p>Before)</p> <table border="1"> <thead> <tr> <th>Part number</th> <th>Package</th> <th>Remarks</th> </tr> </thead> <tbody> <tr> <td>MB91F467DAPFVS-GSE2</td> <td rowspan="4">208-pin plastic QFP (FPT-208P-M04)</td> <td>not recommended</td> </tr> <tr> <td>MB91F467DBPFVS-GSE2</td> <td>not recommended</td> </tr> <tr> <td>MB91F467DAPVS-GSE2</td> <td>not recommended</td> </tr> <tr> <td>MB91F467DBPVS-GSE2</td> <td>Lead-free package</td> </tr> </tbody> </table> <p>After)</p> <table border="1"> <thead> <tr> <th>Part number</th> <th>Package</th> <th>Remarks</th> </tr> </thead> <tbody> <tr> <td>CY91F467DAPFVS-GS-UJE2</td> <td rowspan="4">208-pin plastic QFP (HQB208)</td> <td></td> </tr> <tr> <td>CY91F467DBPFVS-GS-UJE2</td> <td></td> </tr> <tr> <td>CY91F467DAPVSR-GS-UJE2</td> <td></td> </tr> <tr> <td>CY91F467DBPVSR-GS-UJE2</td> <td></td> </tr> </tbody> </table>	Part number	Package	Remarks	MB91F467DAPFVS-GSE2	208-pin plastic QFP (FPT-208P-M04)	not recommended	MB91F467DBPFVS-GSE2	not recommended	MB91F467DAPVS-GSE2	not recommended	MB91F467DBPVS-GSE2	Lead-free package	Part number	Package	Remarks	CY91F467DAPFVS-GS-UJE2	208-pin plastic QFP (HQB208)		CY91F467DBPFVS-GS-UJE2		CY91F467DAPVSR-GS-UJE2		CY91F467DBPVSR-GS-UJE2	
Part number	Package	Remarks																								
MB91F467DAPFVS-GSE2	208-pin plastic QFP (FPT-208P-M04)	not recommended																								
MB91F467DBPFVS-GSE2		not recommended																								
MB91F467DAPVS-GSE2		not recommended																								
MB91F467DBPVS-GSE2		Lead-free package																								
Part number	Package	Remarks																								
CY91F467DAPFVS-GS-UJE2	208-pin plastic QFP (HQB208)																									
CY91F467DBPFVS-GS-UJE2																										
CY91F467DAPVSR-GS-UJE2																										
CY91F467DBPVSR-GS-UJE2																										



**Document History**

Document Title: CY91460D Series FR60 32-bit Microcontroller Document Number: 002-04613				
Revision	ECN	Orig. of Change	Submission Date	Description of Change
**	—	AKIH	08/21/2009	Migrated to Cypress and assigned document number 002-04613. No change to document contents or format.
*A	5207167	AKIH	04/06/2016	Updated to Cypress format.
*B	5969904	MIYH	11/17/2017	Revised the following items: Marketing Part Numbers changed from an MB prefix to a CY prefix for all of these products. Pin Assignment Ordering Information Package Dimension For details, please see 19. Major Changes.

## Sales, Solutions, and Legal Information

### Worldwide Sales and Design Support

Cypress maintains a worldwide network of offices, solution centers, manufacturer's representatives, and distributors. To find the office closest to you, visit us at [Cypress Locations](#).

#### Products

ARM <sup>®</sup> Cortex <sup>®</sup> Microcontrollers	<a href="http://cypress.com/arm">cypress.com/arm</a>
Automotive	<a href="http://cypress.com/automotive">cypress.com/automotive</a>
Clocks & Buffers	<a href="http://cypress.com/clocks">cypress.com/clocks</a>
Interface	<a href="http://cypress.com/interface">cypress.com/interface</a>
Internet of Things	<a href="http://cypress.com/iot">cypress.com/iot</a>
Memory	<a href="http://cypress.com/memory">cypress.com/memory</a>
Microcontrollers	<a href="http://cypress.com/mcu">cypress.com/mcu</a>
PSoC	<a href="http://cypress.com/psoc">cypress.com/psoc</a>
Power Management ICs	<a href="http://cypress.com/pmhc">cypress.com/pmhc</a>
Touch Sensing	<a href="http://cypress.com/touch">cypress.com/touch</a>
USB Controllers	<a href="http://cypress.com/usb">cypress.com/usb</a>
Wireless Connectivity	<a href="http://cypress.com/wireless">cypress.com/wireless</a>

#### PSoC<sup>®</sup> Solutions

[PSoC 1](#) | [PSoC 3](#) | [PSoC 4](#) | [PSoC 5LP](#) | [PSoC 6](#)

#### Cypress Developer Community

[Forums](#) | [WICED IOT Forums](#) | [Projects](#) | [Video](#) | [Blogs](#) | [Training](#) | [Components](#)

#### Technical Support

[cypress.com/support](http://cypress.com/support)

© Cypress Semiconductor Corporation, 2009-2017. This document is the property of Cypress Semiconductor Corporation and its subsidiaries, including Spansion LLC ("Cypress"). This document, including any software or firmware included or referenced in this document ("Software"), is owned by Cypress under the intellectual property laws and treaties of the United States and other countries worldwide. Cypress reserves all rights under such laws and treaties and does not, except as specifically stated in this paragraph, grant any license under its patents, copyrights, trademarks, or other intellectual property rights. If the Software is not accompanied by a license agreement and you do not otherwise have a written agreement with Cypress governing the use of the Software, then Cypress hereby grants you a personal, non-exclusive, nontransferable license (without the right to sublicense) (1) under its copyright rights in the Software (a) for Software provided in source code form, to modify and reproduce the Software solely for use with Cypress hardware products, only internally within your organization, and (b) to distribute the Software in binary code form externally to end users (either directly or indirectly through resellers and distributors), solely for use on Cypress hardware product units, and (2) under those claims of Cypress's patents that are infringed by the Software (as provided by Cypress, unmodified) to make, use, distribute, and import the Software solely for use with Cypress hardware products. Any other use, reproduction, modification, translation, or compilation of the Software is prohibited.

TO THE EXTENT PERMITTED BY APPLICABLE LAW, CYPRESS MAKES NO WARRANTY OF ANY KIND, EXPRESS OR IMPLIED, WITH REGARD TO THIS DOCUMENT OR ANY SOFTWARE OR ACCOMPANYING HARDWARE, INCLUDING, BUT NOT LIMITED TO, THE IMPLIED WARRANTIES OF MERCHANTABILITY AND FITNESS FOR A PARTICULAR PURPOSE. To the extent permitted by applicable law, Cypress reserves the right to make changes to this document without further notice. Cypress does not assume any liability arising out of the application or use of any product or circuit described in this document. Any information provided in this document, including any sample design information or programming code, is provided only for reference purposes. It is the responsibility of the user of this document to properly design, program, and test the functionality and safety of any application made of this information and any resulting product. Cypress products are not designed, intended, or authorized for use as critical components in systems designed or intended for the operation of weapons, weapons systems, nuclear installations, life-support devices or systems, other medical devices or systems (including resuscitation equipment and surgical implants), pollution control or hazardous substances management, or other uses where the failure of the device or system could cause personal injury, death, or property damage ("Unintended Uses"). A critical component is any component of a device or system whose failure to perform can be reasonably expected to cause the failure of the device or system, or to affect its safety or effectiveness. Cypress is not liable, in whole or in part, and you shall and hereby do release Cypress from any claim, damage, or other liability arising from or related to all Unintended Uses of Cypress products. You shall indemnify and hold Cypress harmless from and against all claims, costs, damages, and other liabilities, including claims for personal injury or death, arising from or related to any Unintended Uses of Cypress products.

Cypress, the Cypress logo, Spansion, the Spansion logo, and combinations thereof, WICED, PSoC, CapSense, EZ-USB, F-RAM, and Traveo are trademarks or registered trademarks of Cypress in the United States and other countries. For a more complete list of Cypress trademarks, visit [cypress.com](http://cypress.com). Other names and brands may be claimed as property of their respective owners.

## X-ON Electronics

Largest Supplier of Electrical and Electronic Components

*Click to view similar products for [32-bit Microcontrollers - MCU category](#):*

*Click to view products by [Cypress manufacturer](#):*

Other Similar products are found below :

[MB91F575BHSPMC-GSE1](#) [MB91F594BSPMC-GSE1](#) [PIC32MX120F032B-50I/ML](#) [MB91F464AAPMC-GSE2](#) [MB91F577BHSPMC-GSE1](#)  
[MB91F579CHSPMC1-GSE1](#) [MB91F528USCPMC-GSE2](#) [MB91F248PFV-GE1](#) [MB91F594BPMC-GSE1](#) [MB91243PFV-GS-136E1](#)  
[MB91F577BHSPMC1-GSE1](#) [PIC32MM0032GPL020-E/ML](#) [PIC32MM0016GPL028-E/SS](#) [PIC32MM0016GPL028-E/ML](#)  
[PIC32MM0032GPL028-E/ML](#) [PIC32MM0032GPL028-E/M6](#) [MB91F526KSEPMC-GSE1](#) [FT902L-T](#) [R5F564MLCDFB#31](#)  
[R5F564MLCDFC#31](#) [R5F523E5ADFL#30](#) [R5F524TAADFF#31](#) [PIC32MM0064GPL028-I/ML](#) [PIC32MM0064GPL028-I/SP](#)  
[PIC32MM0064GPL028-I/SO](#) [PIC32MX120F032D-I/TL](#) [PIC32MX130F064D-I/ML](#) [PIC32MZ2064DAB288-I/4J](#) [ATUC256L4U-AUT](#)  
[R5F56318CDBG#U0](#) [PIC32MX150F128C-I/TL](#) [PIC32MX130F064C-ITL](#) [PIC32MX154F128B-V/SO](#) [AT32UC3L0128-AUT](#)  
[PIC32MX150F128D-50I/TL](#) [PIC32MZ1064DAB288-I/4J](#) [PIC32MZ1064DAB169-I/HF](#) [ATUC64D4-Z1UT](#) [AT32UC3A3128S-CTUT](#)  
[ATUC64L3U-Z3UT](#) [MEC1428-SZ-C1](#) [TMS320F28052FPNQ](#) [PIC32MX254F128B-V/SO](#) [AT32UC3L0256-ZAUT](#) [ATUC256L4U-ZAUT](#)  
[PIC32MM0256GPM036-I/M2](#) [PIC32MZ2064DAA169-I/HF](#) [FIDO1100BGB208IR1](#) [FIDO1100PQF208IR1](#) [AT32UC3B1128-AUT](#)