



AMD Opteron™ Processor Power and Thermal Data Sheet



Publication # **30417**
Revision: **3.11**
Issue Date: **May 2006**

Trademarks

AMD, the AMD Arrow logo, AMD Athlon, AMD Opteron and combinations thereof are trademarks of Advanced Micro Devices, Inc.

HyperTransport is a licensed trademark of the HyperTransport Technology Consortium.

Other product names used in this publication are for identification purposes only and may be trademarks of their respective companies.

Disclaimer

The contents of this document are provided in connection with Advanced Micro Devices, Inc. (“AMD”) products. AMD makes no representations or warranties with respect to the accuracy or completeness of the contents of this publication and reserves the right to make changes to specifications and product descriptions at any time without notice. The information contained herein may be of a preliminary or advance nature and is subject to change without notice. No license, whether express, implied, arising by estoppel or otherwise, to any intellectual property rights is granted by this publication. Except as set forth in AMD’s Standard Terms and Conditions of Sale, AMD assumes no liability whatsoever, and disclaims any express or implied warranty, relating to its products including, but not limited to, the implied warranty of merchantability, fitness for a particular purpose, or infringement of any intellectual property right.

AMD’s products are not designed, intended, authorized or warranted for use as components in systems intended for surgical implant into the body, or in other applications intended to support or sustain life, or in any other application in which the failure of AMD’s product could create a situation where personal injury, death, or severe property or environmental damage may occur. AMD reserves the right to discontinue or make changes to its products at any time without notice.

© 2005, 2006 Advanced Micro Devices, Inc. All rights reserved.

Table of Contents

1	AMD Opteron™ Processor	7
1.1	Ordering Part Number Description	7
1.2	AMD Opteron™ Processor Thermal/Power Specifications	27
2	MTOPS	45

List of Figures

Figure 1. AMD Opteron™ Processor Ordering Part Number Example7

List of Tables

Table 1: Revision History	6
Table 2: AMD Opteron™ Processor Part Definition Options	7
Table 3: AMD Opteron™ Processor L2 Cache Size Options	8
Table 4: AMD Opteron™ Processor Temperature Options	8
Table 5: AMD Opteron™ Processor Operating Voltage	9
Table 6: AMD Opteron™ Processor Package Options	9
Table 7: AMD Opteron™ Processor Model Number Options	9
Table 8: AMD Opteron™ Processor Power Limit	10
Table 9: AMD Opteron™ Processor Thermal Profile	10
Table 10: AMD Opteron™ Processor BIOS Specifications - Rev CG	12
Table 11: AMD Opteron™ Processor BIOS Specifications - Rev E Single Core	14
Table 12: AMD Opteron™ Processor BIOS Specifications - Rev E Dual-Core	21
Table 13: AMD Opteron™ Processor Thermal/Power Specifications - Rev B3	27
Table 14: AMD Opteron™ Processor Thermal/Power Specifications - Rev C0	28
Table 15: AMD Opteron™ Processor Thermal/Power Specifications - Rev CG	29
Table 16: AMD Opteron™ Processor Thermal/Power Specifications - Rev E Single-Core	32
Table 17: AMD Opteron™ Processor Thermal/Power Specifications - Rev E Dual-Core	39
Table 18: Composite Theoretical Performance (CTP) Calculations	45

Table 1: Revision History

Date	Revision	Description
May 2006	3.11	Added Rev. E single-core parts.
November 2005	3.09	Added Rev. E single-core and dual-core OPNs. Added MTOPS chapter.
May 2004	3.05	Added Rev CG OPNs for models X40, X42, X44, X46, X48, and X50. Corrected note for S3 state.
March 2004	3.03	Added 55W and 30W OPNs for models X46 and X40.
November 2003	3.00	Initial public release.

1 AMD Opteron™ Processor

The following sections contain thermal/power and related BIOS specifications for AMD Opteron™ processors. Each column in the BIOS and thermal/power tables represents a specific Ordering Part Number (OPN). Section 1.1 provides an example of the OPN structure for this processor family. Availability of processors corresponding to certain OPNs is limited.

Refer to the *AMD Opteron™ Product Data Sheet*, order #23932 for all other electrical specifications for the processor. Refer to the *BIOS and Kernel Developer's Guide for AMD Athlon™ 64 and AMD Opteron™ Processors*, order #26094 for power management BIOS requirements.

1.1 Ordering Part Number Description

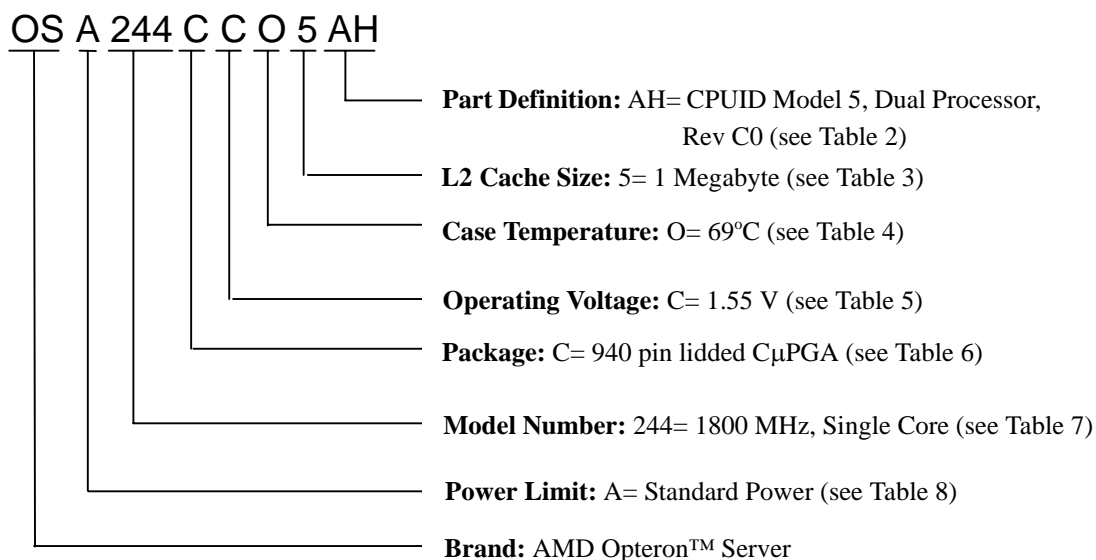

Figure 1. AMD Opteron™ Processor Ordering Part Number Example

Table 2: AMD Opteron™ Processor Part Definition Options

Part Definition	Link Coherency	Revision	Package Drawing
AH	2P	Rev B3	Ceramic
AL	2P	Rev C0	Ceramic
AU	2P	Rev CG	Ceramic
BC	2P	Rev D0	Organic
BL	2P	Rev E4	Organic
CB	2P	Rev E6	Organic
AG	1P	Rev B3	Ceramic

Table 2: AMD Opteron™ Processor Part Definition Options

Part Definition	Link Coherency	Revision	Package Drawing
AK	1P	Rev C0	Ceramic
AT	1P	Rev CG	Ceramic
BB	1P	Rev D0	Organic
BK	1P	Rev E4	Organic
BN	1P	Rev E4	Organic
CA	1P	Rev E6	Organic
CD	1P	Rev E6	D1
AI	8P	Rev B3	Ceramic
AM	8P	Rev C0	Ceramic
AV	8P	Rev CG	Ceramic
BD	8P	Rev D0	Organic
BS	8P	Rev E1	Organic
BM	8P	Rev E4	Organic
CC	8P	Rev E6	Organic

Table 3: AMD Opteron™ Processor L2 Cache Size Options

OPN Character	Cache Size
6	2 MB
5	1 MB

Table 4: AMD Opteron™ Processor Temperature Options

OPN Character	Temperature
A	Variable
K	65°C
M	67°C
O	69°C
P	70°C
Q	71°C
T	78°C
U	83°C

Table 5: AMD Opteron™ Processor Operating Voltage

OPN Character	Operating Voltage
A	Variable
C	1.55 V
E	1.50 V
I	1.40 V
K	1.35 V
M	1.30 V
O	1.25 V
Q	1.20 V
S	1.15 V

Table 6: AMD Opteron™ Processor Package Options

OPN Character	Package
C	940 Pin Lidded C μ PGA
F	940 Pin Lidded O μ PGA
D	939 Pin Lidded O μ PGA

Table 7: AMD Opteron™ Processor Model Number Options

Uni-Processor, Single-Core	Dual-Processor, Single-Core	Multi-Processor, Single-Core
140: 1400 MHz	240: 1400 MHz	840: 1400 MHz
142: 1600 MHz	242: 1600 MHz	842: 1600 MHz
144: 1800 MHz	244: 1800 MHz	844: 1800 MHz
146: 2000 MHz	246: 2000 MHz	846: 2000 MHz
148: 2200 MHz	248: 2200 MHz	848: 2200 MHz
150: 2400 MHz	250: 2400 MHz	850: 2400 MHz
152: 2600 MHz	252: 2600 MHz	852: 2600 MHz
154: 2800 MHz	254: 2800 MHz	854: 2800 MHz
156: 3000 MHz	256: 3000 MHz	856: 3000 MHz
—	260: 1600 MHz	860: 1600 MHz
165: 1800 MHz	265: 1800 MHz	865: 1800 MHz
170: 2000 MHz	270: 2000 MHz	870: 2000 MHz
175: 2200 MHz	—	875: 2200 MHz
180: 2400 MHz	280: 2400 MHz	880: 2400 MHz

Table 8: AMD Opteron™ Processor Power Limit

OPN Character	Power Limit
A	Standard Power
K	55 W
B	30 W

Table 9: AMD Opteron™ Processor Thermal Profile

Thermal Profile	A	B	C
Thermal Resistance (case to ambient)	0.34°C/W	0.27°C/W	0.53°C/W
Local Ambient Temperature	42°C	42°C	42°C
Tcase Max	Power (Thermal Profile A)	Power (Thermal Profile B)	Power (Thermal Profile C)
49°C	20.6 W	25.9 W	13.2 W
51°C	26.5 W	33.3 W	17.0 W
53°C	32.4 W	40.7 W	20.8 W
55°C	38.2 W	48.1 W	24.5 W
57°C	44.1 W	55.6 W	28.3 W
59°C	50.0 W	63.0 W	32.1 W
61°C	55.9 W	70.4 W	35.8 W
63°C	61.8 W	77.8 W	39.6 W
65°C	67.6 W	85.2 W	43.4 W
67°C	73.5 W	92.6 W	47.2 W
69°C	79.4 W	N/A	50.9 W
71°C	85.3 W	N/A	54.7 W

Thermal Profile	D	E	F
Thermal Resistance (case to ambient)	0.34°C/W	0.95°C/W	0.25°C/W
Local Ambient Temperature	42°C	42°C	42°C
Tcase Max	Power (Thermal Profile D)	Power (Thermal Profile E)	Power (Thermal Profile F)
49°C	20.6 W	7.4 W	28.0 W
51°C	26.5 W	9.5 W	36.0 W
53°C	32.4 W	11.6 W	44.0 W
55°C	38.2 W	13.7 W	52.0 W
57°C	44.1 W	15.8 W	60.0 W
59°C	50.0 W	17.9 W	68.0 W
61°C	55.9 W	20.0 W	76.0 W
63°C	61.8 W	22.1 W	84.0 W
65°C	67.0 W	24.2 W	92.0 W
67°C	N/A	26.3 W	95.0 W
69°C	N/A	28.4 W	N/A
71°C	N/A	30.0 W	N/A

Thermal Profile	G	H	I
Thermal Resistance (case to ambient)	0.51°C/W	0.22°C/W	0.20°C/W
Local Ambient Temperature	42°C	42°C	42°C
Tcase Max	Power (Thermal Profile G)	Power (Thermal Profile H)	Power (Thermal Profile I)
49°C	13.7 W	31.8 W	35.0 W
51°C	17.6 W	40.9 W	45.0 W
53°C	21.6 W	50.0 W	55.0 W
55°C	25.5 W	59.1 W	65.0 W
57°C	29.4 W	68.2 W	75.0 W
59°C	33.3 W	77.3 W	85.0 W
61°C	37.3 W	86.4 W	95.0 W
63°C	41.2 W	95.5 W	105.0 W
65°C	45.1 W	104.0 W	110.0 W
67°C	49.0 W	N/A	N/A
69°C	52.9 W	N/A	N/A
71°C	55.0 W	N/A	N/A

Note: The thermal profile is used to define the relationship between Tcase max and device-specific Thermal Design Power for Rev. E and later processors with "Variable" indicated by the Case Temperature OPN character.

Table 10: AMD Opteron™ Processor BIOS Specifications - Rev CG

Parameter/OPN	Notes	OSA140CEP5AT			OSA142CEP5AT			OSA144CEP5AT		
		OSA240CEP5AU	OSA242CEP5AU	OSA840CEP5AV	OSA242CEP5AU	OSA842CEP5AV	OSA244CEP5AU	OSA844CEP5AV	OSA844CEP5AV	
Model Number		140	240	840	142	242	842	144	244	844
CPUID 8000_0001h EBX [11:6] (BrandID)	1	0Ch	10h	14h	0Ch	10h	14h	0Ch	10h	14h
CPUID 8000_0001h EAX [31:0] (CPUID)	1	00000F5Ah			00000F5Ah			00000F5Ah		
L2 Cache Size		1 MB			1 MB			1 MB		
FID/VID Status MaxFID Field	2	06h			08h			0Ah		
FID/VID Status StartFID Field	2	06h			08h			0Ah		
Max P-State		1400 MHz			1600 MHz			1800 MHz		
FID/VID Status MaxVID Field	2	00h			00h			00h		
FID/VID Status StartVID Field	2	02h			02h			02h		
VID Code		02h			02h			02h		
VID_VDD	4	1.500 V			1.500 V			1.500 V		
Thermal Design Power	5	82.1 W			82.1 W			82.1 W		
Intermediate P-State #1	6	N/A			N/A			N/A		
VID Code / VID_VDD	4									
Thermal Design Power	5									
Intermediate P-State #2	6	N/A			N/A			N/A		
VID Code / VID_VDD	4									
Thermal Design Power	5									
Intermediate P-State #3	6	N/A			N/A			N/A		
VID Code / VID_VDD	4									
Thermal Design Power	5									
Min P-State		N/A			N/A			1000 MHz		
VID Code / VID_VDD	4							0Eh	1.200 V	
Thermal Design Power	5							28.0 W		

The notes for this table appear on page 26.

Parameter/OPN	Notes	OSA146CEP5AT			OSA148CEP5AT			OSA150CEP5AT		
		OSA246CEP5AU	OSA248CEP5AU	OSA250CEP5AU	OSA846CEP5AV	OSA848CEP5AV	OSA850CEP5AV	OSA246CEP5AU	OSA248CEP5AU	OSA250CEP5AU
Model Number		146	246	846	148	248	848	150	250	850
CPUID 8000_0001h EBX [11:6] (BrandID)	1	0Ch	10h	14h	0Ch	10h	14h	0Ch	10h	14h
CPUID 8000_0001h EAX [31:0] (CPUID)	1	00000F5Ah			00000F5Ah			00000F5Ah		
L2 Cache Size		1 MB			1 MB			1 MB		
FID/VID Status MaxFID Field	2	0Ch			0Eh			10h		
FID/VID Status StartFID Field	2	0Ch			0Eh			10h		
Max P-State		2000 MHz			2200 MHz			2400 MHz		
FID/VID Status MaxVID Field	2	00h			00h			00h		
FID/VID Status StartVID Field	2	02h			02h			02h		
VID Code		02h			02h			02h		
VID_VDD	4	1.500 V			1.500 V			1.500 V		
Thermal Design Power	5	89.0 W			89.0 W			89.0 W		
Intermediate P-State #1	6	1800 MHz			2000 MHz			2200 MHz		
VID Code / VID_VDD	4	06h	1.400 V		06h	1.400 V		06h	1.400 V	
Thermal Design Power	5	66.0 W			70.0 W			83.0 W		
Intermediate P-State #2	6	N/A			1800 MHz			2000 MHz		
VID Code / VID_VDD	4				0Ah	1.300 V		0Ah	1.300 V	
Thermal Design Power	5				47.0 W			55.0 W		
Intermediate P-State #3	6	N/A			N/A			1800 MHz		
VID Code / VID_VDD	4							0Ch	1.250 V	
Thermal Design Power	5							42.0 W		
Min P-State		1000 MHz			1000 MHz			1000 MHz		
VID Code / VID_VDD	4	0Eh	1.200 V		0Eh	1.200 V		0Eh	1.200 V	
Thermal Design Power	5	28.0 W			28.0 W			28.0 W		

The notes for this table appear on page 26.

Table 11: AMD Opteron™ Processor BIOS Specifications - Rev E Single Core

Parameter/OPN	Notes	OSA152FAA5BK OSA252FAA5BL OSA852FAA5BM			OSA254FAA5BL OSA854FAA5BM	
		152	252	852	254	854
Model Number		152	252	852	254	854
CPUID 8000_0001h EBX [11:6] (BrandID)	1	0Ch	10h	14h	10h	14h
CPUID 8000_0001h EAX [31:0] (CPUID)	1	00020F51h			00020F51h	
L2 Cache Size		1 MB			1 MB	
FID/VID Status MaxFID Field	2	12h			14h	
FID/VID Status StartFID Field	2	12h			14h	
Max P-State		2600 MHz			2800 MHz	
FID/VID Status MaxVID Field	2, 3	06h	04h		06h	04h
FID/VID Status StartVID Field	2, 3	08h	06h		08h	06h
VID Code		08h	06h		08h	06h
VID_VDD	4	1.350 V	1.400 V		1.350 V	1.400 V
Thermal Design Power	5	92.6 W			92.6 W	
Intermediate P-State #1	6	2400 MHz			2600 MHz	
VID Code / VID_VDD	4	08h	1.350 V		08h	1.350 V
Thermal Design Power	5	90.0 W			90.2 W	
Intermediate P-State #2	6	2200 MHz			2400 MHz	
VID Code / VID_VDD	4	0Ah	1.300 V		0Ah	1.300 V
Thermal Design Power	5	76.6 W			77.0 W	
Intermediate P-State #3	6	2000 MHz			2200 MHz	
VID Code / VID_VDD	4	0Ch	1.250 V		0Ch	1.250 V
Thermal Design Power	5	65.1 W			65.7 W	
Intermediate P-State #4	6	1800 MHz			2000 MHz	
VID Code / VID_VDD	4	0Eh	1.200 V		0Eh	1.200 V
Thermal Design Power	5	55.2 W			55.9 W	
Intermediate P-State #5	6	N/A			1800 MHz	
VID Code / VID_VDD	4				10h	1.150 V
Thermal Design Power	5				47.6 W	
Intermediate P-State #6	6	N/A			N/A	
VID Code / VID_VDD	4					
Thermal Design Power	5					
Min P-State		1000 MHz			1000 MHz	
VID Code / VID_VDD	4	12h	1.100 V		12h	1.100 V
Thermal Design Power	5	32.0 W			36.1 W	

The notes for this table appear on page 26.

Parameter/OPN	Notes	OSA242FAA5BL OSA842FAA5BM		OSA244FAA5BL OSA844FAA5BM		OSA246FAA5BL OSA846FAA5BM	
Model Number		242	842	244	844	246	846
CPUID 8000_0001h EBX [11:6] (BrandID)	1	10h	14h	10h	14h	10h	14h
CPUID 8000_0001h EAX [31:0] (CPUID)	1	00020F51h		00020F51h		00020F51h	
L2 Cache Size		1 MB		1 MB		1 MB	
FID/VID Status MaxFID Field	2	08h		0Ah		0Ch	
FID/VID Status StartFID Field	2	08h		0Ah		0Ch	
Max P-State		1600 MHz		1800 MHz		2000 MHz	
FID/VID Status MaxVID Field	2, 3	06h	04h	06h	04h	06h	04h
FID/VID Status StartVID Field	2, 3	08h	06h	08h	06h	08h	06h
VID Code		08h	06h	08h	06h	08h	06h
VID_VDD	4	1.350 V	1.400 V	1.350 V	1.400 V	1.350 V	1.400 V
Thermal Design Power	5	85.3 W		85.3 W		85.3 W	
Intermediate P-State #1	6	N/A		N/A		1800 MHz	
VID Code / VID_VDD	4					08h	1.350 V
Thermal Design Power	5					82.7 W	
Intermediate P-State #2	6	N/A		N/A		N/A	
VID Code / VID_VDD	4						
Thermal Design Power	5						
Intermediate P-State #3	6	N/A		N/A		N/A	
VID Code / VID_VDD	4						
Thermal Design Power	5						
Intermediate P-State #4	6	N/A		N/A		N/A	
VID Code / VID_VDD	4						
Thermal Design Power	5						
Intermediate P-State #5	6	N/A		N/A		N/A	
VID Code / VID_VDD	4						
Thermal Design Power	5						
Intermediate P-State #6	6	N/A		N/A		N/A	
VID Code / VID_VDD	4						
Thermal Design Power	5						
Min P-State		N/A		1000 MHz		1000 MHz	
VID Code / VID_VDD	4			12h	1.100 V	12h	1.100 V
Thermal Design Power	5			37.8 W		36.6 W	

The notes for this table appear on page 26.

Parameter/OPN	Notes	OSA248FAA5BL OSA848FAA5BM		OSA250FAA5BL OSA850FAA5BM	
Model Number		248	848	250	850
CPUID 8000_0001h EBX [11:6] (BrandID)	1	10h	14h	10h	14h
CPUID 8000_0001h EAX [31:0] (CPUID)	1	00020F51h		00020F51h	
L2 Cache Size		1 MB		1 MB	
FID/VID Status MaxFID Field	2	0Eh		10h	
FID/VID Status StartFID Field	2	0Eh		10h	
Max P-State		2200 MHz		2400 MHz	
FID/VID Status MaxVID Field	2, 3	06h	04h	06h	04h
FID/VID Status StartVID Field	2, 3	08h	06h	08h	06h
VID Code		08h	06h	08h	06h
VID_VDD	4	1.350 V	1.400 V	1.350 V	1.400 V
Thermal Design Power	5	85.3 W		85.3 W	
Intermediate P-State #1	6	2000 MHz		2200 MHz	
VID Code / VID_VDD	4	08h	1.350 V	08h	1.350 V
Thermal Design Power	5	82.7 W		82.7 W	
Intermediate P-State #2	6	1800 MHz		2000 MHz	
VID Code / VID_VDD	4	0Ah	1.300 V	0Ah	1.300 V
Thermal Design Power	5	70.0 W		70.2 W	
Intermediate P-State #3	6	N/A		1800 MHz	
VID Code / VID_VDD	4			0Ch	1.250 V
Thermal Design Power	5			59.5 W	
Intermediate P-State #4	6	N/A		N/A	
VID Code / VID_VDD	4				
Thermal Design Power	5				
Intermediate P-State #5	6	N/A		N/A	
VID Code / VID_VDD	4				
Thermal Design Power	5				
Intermediate P-State #6	6	N/A		N/A	
VID Code / VID_VDD	4				
Thermal Design Power	5				
Min P-State		1000 MHz		1000 MHz	
VID Code / VID_VDD	4	12h	1.100 V	12h	1.100 V
Thermal Design Power	5	36.6 W		30.1 W	

The notes for this table appear on page 26.

Parameter/OPN	Notes	OSK246FAA5BL OSK846FAA5BM		OSK848FAA5BM			OSK250FAA5BL OSK850FAA5BM	
Model Number		246	846	148	248	848	250	850
CPUID 8000_0001h EBX [11:6] (BrandID)	1	12h	16h	0Eh	12h	16h	12h	16h
CPUID 8000_0001h EAX [31:0] (CPUID)	1	00020F51h		00020F51h			00020F51h	
L2 Cache Size		1 MB		1 MB			1 MB	
FID/VID Status MaxFID Field	2	0Ch		0Eh			10h	
FID/VID Status StartFID Field	2	0Ch		0Eh			10h	
Max P-State		2000 MHz		2200 MHz			2400 MHz	
FID/VID Status MaxVID Field	2, 3	06h	04h	06h	04h	06h	04h	
FID/VID Status StartVID Field	2, 3	08h	06h	08h	06h	08h	06h	
VID Code		08h	06h	08h	06h	08h	06h	
VID_VDD	4	1.350 V	1.400 V	1.350 V	1.400 V	1.350 V	1.400 V	
Thermal Design Power	5	54.7 W		54.7 W			54.7 W	
Intermediate P-State #1	6	1800 MHz		2000 MHz			2200 MHz	
VID Code / VID_VDD	4	08h	1.350 V	08h	1.350 V	08h	1.350 V	
Thermal Design Power	5	46.1 W		52.1 W			52.1 W	
Intermediate P-State #2	6	N/A		1800 MHz			2000 MHz	
VID Code / VID_VDD	4			0Ah	1.300 V	0Ah	1.300 V	
Thermal Design Power	5			45.9 W			44.0 W	
Intermediate P-State #3	6	N/A		N/A			1800 MHz	
VID Code / VID_VDD	4					0Ch	1.250 V	
Thermal Design Power	5						37.9 W	
Intermediate P-State #4	6	N/A		N/A			N/A	
VID Code / VID_VDD	4							
Thermal Design Power	5							
Intermediate P-State #5	6	N/A		N/A			N/A	
VID Code / VID_VDD	4							
Thermal Design Power	5							
Intermediate P-State #6	6	N/A		N/A			N/A	
VID Code / VID_VDD	4							
Thermal Design Power	5							
Min P-State		1000 MHz		1000 MHz			1000 MHz	
VID Code / VID_VDD	4	12h	1.100 V	12h	1.100 V	12h	1.100 V	
Thermal Design Power	5	22.3 W		21.1 W			19.9 W	

The notes for this table appear on page 26.

Parameter/OPN	Notes	OSA144DAA5BN		OSA148DAA5BN	
Model Number		144		148	
CPUID 8000_0001h EBX [11:6] (BrandID)	1	0Ch		0Ch	
CPUID 8000_0001h EAX [31:0] (CPUID)	1	00020F71h		00020F71h	
L2 Cache Size		1 MB		1 MB	
FID/VID Status MaxFID Field	2	0Ah		0Eh	
FID/VID Status StartFID Field	2	0Ah		0Eh	
Max P-State		1800 MHz		2200 MHz	
FID/VID Status MaxVID Field	2, 3	06h	04h	06h	04h
FID/VID Status StartVID Field	2, 3	08h	06h	08h	06h
VID Code		08h	06h	08h	06h
VID_VDD	4	1.350 V	1.400 V	1.350 V	1.400 V
Thermal Design Power	5	67.0 W		85.3 W	
Intermediate P-State #1	6	N/A		2000 MHz	
VID Code / VID_VDD	4			08h	1.350 V
Thermal Design Power	5			83.0 W	
Intermediate P-State #2	6	N/A		1800 MHz	
VID Code / VID_VDD	4			0Ah	1.300 V
Thermal Design Power	5			70.4 W	
Intermediate P-State #3	6	N/A		N/A	
VID Code / VID_VDD	4				
Thermal Design Power	5				
Intermediate P-State #4	6	N/A		N/A	
VID Code / VID_VDD	4				
Thermal Design Power	5				
Intermediate P-State #5	6	N/A		N/A	
VID Code / VID_VDD	4				
Thermal Design Power	5				
Intermediate P-State #6	6	N/A		N/A	
VID Code / VID_VDD	4				
Thermal Design Power	5				
Min P-State		1000 MHz		1000 MHz	
VID Code / VID_VDD	4	12h	1.100 V	12h	1.100 V
Thermal Design Power	5	29.6 W		36.1 W	

The notes for this table appear on page 26.

Parameter/OPN	Notes	OSA152DAA5BN	
Model Number		152	
CPUID 8000_0001h EBX [11:6] (BrandID)	1	0Ch	
CPUID 8000_0001h EAX [31:0] (CPUID)	1	00020F71h	
L2 Cache Size		1 MB	
FID/VID Status MaxFID Field	2	12h	
FID/VID Status StartFID Field	2	12h	
Max P-State		2600 MHz	
FID/VID Status MaxVID Field	2, 3	06h	04h
FID/VID Status StartVID Field	2, 3	08h	06h
VID Code		08h	06h
VID_VDD	4	1.350 V	1.400 V
Thermal Design Power	5	104.0 W	
Intermediate P-State #1	6	2400 MHz	
VID Code / VID_VDD	4	08h	1.350 V
Thermal Design Power	5	101.6 W	
Intermediate P-State #2	6	2200 MHz	
VID Code / VID_VDD	4	0Ah	1.300 V
Thermal Design Power	5	86.3 W	
Intermediate P-State #3	6	2000 MHz	
VID Code / VID_VDD	4	0Ch	1.250 V
Thermal Design Power	5	73.2 W	
Intermediate P-State #4	6	1800 MHz	
VID Code / VID_VDD	4	0Eh	1.200 V
Thermal Design Power	5	62.1 W	
Intermediate P-State #5	6	N/A	
VID Code / VID_VDD	4		
Thermal Design Power	5		
Intermediate P-State #6	6	N/A	
VID Code / VID_VDD	4		
Thermal Design Power	5		
Min P-State		1000 MHz	
VID Code / VID_VDD	4	12h	1.100 V
Thermal Design Power	5	41.9 W	

The notes for this table appear on page 26.

Parameter/OPN	Notes	OSA146DAA5BN		OSA150DAA5BN		OSA154DAA5BN	
Model Number		146		150		154	
CPUID 8000_0001h EBX [11:6] (BrandID)	1	0Ch		0Ch		0Ch	
CPUID 8000_0001h EAX [31:0] (CPUID)	1	00020F71h		00020F71h		00020F71h	
L2 Cache Size		1 MB		1 MB		1 MB	
FID/VID Status MaxFID Field	2	0Ch		10h		14h	
FID/VID Status StartFID Field	2	0Ch		10h		14h	
Max P-State		2000 MHz		2400 MHz		2800 MHz	
FID/VID Status MaxVID Field	2, 3	06h	04h	06h	04h	06h	04h
FID/VID Status StartVID Field	2, 3	08h	06h	08h	06h	08h	06h
VID Code		08h	06h	08h	06h	08h	06h
VID_VDD	4	1.350 V	1.400 V	1.350 V	1.400 V	1.350 V	1.400 V
Thermal Design Power	5	67.0 W		85.3 W		104.0 W	
Intermediate P-State #1	6	1800 MHz		2200 MHz		2600 MHz	
VID Code / VID_VDD	4	08h	1.350 V	08h	1.350 V	08h	1.350 V
Thermal Design Power	5	64.7 W		83.0 W		101.7 W	
Intermediate P-State #2	6	N/A		2000 MHz		2400 MHz	
VID Code / VID_VDD	4			0Ah	1.300 V	0Ah	1.300 V
Thermal Design Power	5			70.6 W		86.8 W	
Intermediate P-State #3	6	N/A		1800 MHz		2200 MHz	
VID Code / VID_VDD	4			0Ch	1.250 V	0Ch	1.250 V
Thermal Design Power	5			59.6 W		74.0 W	
Intermediate P-State #4	6	N/A		N/A		2000 MHz	
VID Code / VID_VDD	4					0Eh	1.200 V
Thermal Design Power	5					63.0 W	
Intermediate P-State #5	6	N/A		N/A		1800 MHz	
VID Code / VID_VDD	4					10h	1.150 V
Thermal Design Power	5					53.7 W	
Intermediate P-State #6	6	N/A		N/A		N/A	
VID Code / VID_VDD	4						
Thermal Design Power	5						
Min P-State		1000 MHz		1000 MHz		1000 MHz	
VID Code / VID_VDD	4	12h	1.100 V	12h	1.100 V	12h	1.100 V
Thermal Design Power	5	28.6 W		35.0 W		41.6 W	

The notes for this table appear on page 26.

Table 12: AMD Opteron™ Processor BIOS Specifications - Rev E Dual-Core

Parameter/OPN	Notes	OSA865FAA6CC			OSA870FAA6CC		OSA875FAA6CC	
		165	265	865	270	870	275	875
Model Number		165	265	865	270	870	275	875
CPUID 8000_0001h EBX [11:6] (BrandID)	1	2Ch	30h	34h	30h	34h	30h	34h
CPUID 8000_0001h EAX [31:0] (CPUID)	1	00020F12h			00020F12h		00020F12h	
L2 Cache Size		2 MB			2 MB		2 MB	
FID/VID Status MaxFID Field	2	0Ah			0Ch		0Eh	
FID/VID Status StartFID Field	2	0Ah			0Ch		0Eh	
Max HyperTransport™ Frequency		800 MHz			800 MHz		800 MHz	
Max P-State		1800 MHz			2000 MHz		2200 MHz	
FID/VID Status MaxVID Field	2, 3	08h	06h		08h	06h	08h	06h
FID/VID Status StartVID Field	2, 3	0Ah	08h		0Ah	08h	0Ah	08h
VID Code		0Ah	08h		0Ah	08h	0Ah	08h
VID_VDD	4	1.350 V	0.000 V		1.350 V	0.000 V	1.350 V	0.000 V
Thermal Design Power	5, 8	95.0 W			95.0 W		95.0 W	
Intermediate P-State #1	6	N/A			1800 MHz		2000 MHz	
VID Code / VID_VDD	4				0Ah	1.300 V	0Ah	1.300 V
Thermal Design Power	5, 8				90.3 W		90.3 W	
Intermediate P-State #2	6	N/A			N/A		1800 MHz	
VID Code / VID_VDD	4						0Ch	1.250 V
Thermal Design Power	5, 8						75.9 W	
Intermediate P-State #3	6	N/A			N/A		N/A	
VID Code / VID_VDD	4							
Thermal Design Power	5, 8							
Intermediate P-State #4	6	N/A			N/A		N/A	
VID Code / VID_VDD	4							
Thermal Design Power	5, 8							
Intermediate P-State #5	6	N/A			N/A		N/A	
VID Code / VID_VDD	4							
Thermal Design Power	5, 8							
Intermediate P-State #6	6	N/A			N/A		N/A	
VID Code / VID_VDD	4							
Thermal Design Power	5, 8							
Min P-State		1000 MHz			1000 MHz		1000 MHz	
VID Code / VID_VDD	4	12h	1.100 V		12h	1.100 V	12h	1.100 V
Thermal Design Power	5, 8	40.6 W			38.3 W		36.1 W	

The notes for this table appear on page 26.

Parameter/OPN	Notes	OSA280FAA6CB OSA880FAA6CC	
Model Number		280	880
CPUID 8000_0001h EBX [11:6] (BrandID)	1	30h	34h
CPUID 8000_0001h EAX [31:0] (CPUID)	1	00020F12h	
L2 Cache Size		2 MB	
FID/VID Status MaxFID Field	2	10h	
FID/VID Status StartFID Field	2	10h	
Max HyperTransport Frequency		800 MHz	
Max P-State		1800 MHz	
FID/VID Status MaxVID Field	2, 3	08h	06h
FID/VID Status StartVID Field	2, 3	0Ah	08h
VID Code		0Ah	08h
VID_VDD	4	1.350 V	1.400 V
Thermal Design Power	5, 8	92.6 W	
Intermediate P-State #1	6	2400 MHz	
VID Code / VID_VDD	4	0Ah	1.350 V
Thermal Design Power	5, 8	90.0 W	
Intermediate P-State #2	6	2200 MHz	
VID Code / VID_VDD	4	0Ch	1.300 V
Thermal Design Power	5, 8	76.6 W	
Intermediate P-State #3	6	2000 MHz	
VID Code / VID_VDD	4	0Eh	1.250 V
Thermal Design Power	5, 8	65.1 W	
Intermediate P-State #4	6	1800 MHz	
VID Code / VID_VDD	4		1.200 V
Thermal Design Power	5, 8	55.2 W	
Intermediate P-State #5	6	N/A	
VID Code / VID_VDD	4		
Thermal Design Power	5, 8		
Intermediate P-State #6	6	N/A	
VID Code / VID_VDD	4		
Thermal Design Power	5, 8		
Min P-State		1000 MHz	
VID Code / VID_VDD	4	12h	1.100 V
Thermal Design Power	5, 8	32.0 W	

The notes for this table appear on page 26.

Parameter/OPN	Notes	OSA165DAA6CD		OSA170DAA6CD		OSA175DAA6CD	
Model Number		165		170		175	
CPUID 8000_0001h EBX [11:6] (BrandID)	1	2Ch		2Ch		2Ch	
CPUID 8000_0001h EAX [31:0] (CPUID)	1	00020F32h		00020F32h		00020F32h	
L2 Cache Size		2 MB		2 MB		2 MB	
FID/VID Status MaxFID Field	2	0Ah		0Ch		0Eh	
FID/VID Status StartFID Field	2	0Ah		0Ch		0Eh	
Max P-State		1800 MHz		2000 MHz		2200 MHz	
FID/VID Status MaxVID Field	2, 3	08h	06h	08h	06h	08h	06h
FID/VID Status StartVID Field	2, 3	0Ah	08h	0Ah	08h	0Ah	08h
VID Code		0Ah	08h	0Ah	08h	0Ah	08h
VID_VDD	4	1.300 V	1.350 V	1.300 V	1.350 V	1.300 V	1.350 V
Thermal Design Power	5	110.0 W		110.0 W		110.0 W	
Intermediate P-State #1	6	N/A		1800 MHz		2000 MHz	
VID Code / VID_VDD	4			0Ah	1.300 V	0Ah	1.300 V
Thermal Design Power	5			105.6 W		105.6 W	
Intermediate P-State #2	6	N/A		N/A		1800 MHz	
VID Code / VID_VDD	4					0Ch	1.250 V
Thermal Design Power	5					89.1 W	
Intermediate P-State #3	6	N/A		N/A		N/A	
VID Code / VID_VDD	4						
Thermal Design Power	5						
Intermediate P-State #4	6	N/A		N/A		N/A	
VID Code / VID_VDD	4						
Thermal Design Power	5						
Intermediate P-State #5	6	N/A		N/A		N/A	
VID Code / VID_VDD	4						
Thermal Design Power	5						
Intermediate P-State #6	6	N/A		N/A		N/A	
VID Code / VID_VDD	4						
Thermal Design Power	5						
Min P-State		1000 MHz		1000 MHz		1000 MHz	
VID Code / VID_VDD	4	12h	1.100 V	12h	1.100 V	12h	1.100 V
Thermal Design Power	5	51.6 W		51.4 W		49.0 W	

The notes for this table appear on page 26.

Parameter/OPN	Notes	OSK260FAA6CB OSK860FAA6CC		OSK265FAA6CB OSK865FAA6CC			OSK270FAA6CB OSK870FAA6CC	
Model Number		260	860	165	265	865	270	870
CPUID 8000_0001h EBX [11:6] (BrandID)	1	32h	36h	2Eh	32h	36h	32h	36h
CPUID 8000_0001h EAX [31:0] (CPUID)	1	00020F12h		00020F12h			00020F12h	
L2 Cache Size		2 MB		2 MB			2 MB	
FID/VID Status MaxFID Field	2	08h		0Ah			0Ch	
FID/VID Status StartFID Field	2	08h		0Ah			0Ch	
Max HyperTransport Frequency		800 MHz		800 MHz			800 MHz	
Max P-State		1600 MHz		1800 MHz			2000 MHz	
FID/VID Status MaxVID Field	2, 3	0Eh	0Ch	0Eh	0Ch	0Eh	0Ch	0Ch
FID/VID Status StartVID Field	2, 3	10h	0Eh	10h	0Eh	10h	0Eh	0Eh
VID Code		10h	0Eh	10h	0Eh	10h	0Eh	0Eh
VID_VDD	4	1.150 V	1.200 V	1.150 V	1.200 V	1.150 V	1.200 V	1.200 V
Thermal Design Power	5, 8	55.0 W		55.0 W			55.0 W	
Intermediate P-State #1	6	N/A		N/A			1800 MHz	
VID Code / VID_VDD	4					10h	1.150 V	
Thermal Design Power	5, 8						52.0 W	
Intermediate P-State #2	6	N/A		N/A			N/A	
VID Code / VID_VDD	4							
Thermal Design Power	5, 8							
Intermediate P-State #3	6	N/A		N/A			N/A	
VID Code / VID_VDD	4							
Thermal Design Power	5, 8							
Intermediate P-State #4	6	N/A		N/A			N/A	
VID Code / VID_VDD	4							
Thermal Design Power	5, 8							
Intermediate P-State #5	6	N/A		N/A			N/A	
VID Code / VID_VDD	4							
Thermal Design Power	5, 8							
Intermediate P-State #6	6	N/A		N/A			N/A	
VID Code / VID_VDD	4							
Thermal Design Power	5, 8							
Min P-State		N/A		1000 MHz			1000 MHz	
VID Code / VID_VDD	4			12h	1.100 V	12h	1.100 V	
Thermal Design Power	5, 8			36.5 W			33.5 W	

The notes for this table appear on page 26.

Parameter/OPN	Notes	OSA180DAA6CD	
Model Number		180	
CPUID 8000_0001h EBX [11:6] (BrandID)	1	2Ch	
CPUID 8000_0001h EAX [31:0] (CPUID)	1	00020F32h	
L2 Cache Size		2 MB	
FID/VID Status MaxFID Field	2	10h	
FID/VID Status StartFID Field	2	10h	
Max P-State		2400 MHz	
FID/VID Status MaxVID Field	2, 3	08h	06h
FID/VID Status StartVID Field	2, 3	0Ah	08h
VID Code		0Ah	08h
VID_VDD	4	1.300 V	1.350 V
Thermal Design Power	5	110.0 W	
Intermediate P-State #1	6	2200 MHz	
VID Code / VID_VDD	4	0Ah	1.300 V
Thermal Design Power	5	105.6 W	
Intermediate P-State #2	6	2000 MHz	
VID Code / VID_VDD	4	0Ch	1.250 V
Thermal Design Power	5	89.1 W	
Intermediate P-State #3	6	1800 MHz	
VID Code / VID_VDD	4	0Eh	1.200 V
Thermal Design Power	5	74.8 W	
Intermediate P-State #4	6	N/A	
VID Code / VID_VDD	4		
Thermal Design Power	5		
Intermediate P-State #5	6	N/A	
VID Code / VID_VDD	4		
Thermal Design Power	5		
Intermediate P-State #6	6	N/A	
VID Code / VID_VDD	4		
Thermal Design Power	5		
Min P-State		1000 MHz	
VID Code / VID_VDD	4	12h	1.100 V
Thermal Design Power	5	46.6 W	

The notes for this table appear on page 26.

Notes:

1. CPUID extended function 8000_0001h fields are used by BIOS in uniquely associating a given processor to the P-states that are valid for that processor. Refer to the BIOS and Kernel Developer's Guide for AMD Athlon™ 64 and AMD Opteron™ Processors, order# 26094.
2. FIDVID Status Register, MSR C001_0042h.
3. StartVID and MaxVID are programmed during device manufacturing with part-specific values for Rev E and later processors with 'Variable' indicated by the Operating Voltage OPN character, and can have one or more valid options. All valid options for StartVID, MaxVID, and VID_VDD will be specified for the corresponding OPN. For information on the relationship of StartVID and MaxVID to VID_VDD refer to the BIOS and Kernel Developer's Guide for AMD Athlon™ 64 and AMD Opteron™ Processors, order# 26094.
4. The VID_VDD voltage is the VID[4:0] requested VDD supply level. Refer to the appropriate functional data sheet for details.
5. Thermal Design Power (TDP) is measured under the conditions of Tcase Max and VDD=VID_VDD, and include all power dissipated on-die from VDD, VDDIO, VLDT, VTT, and VDDA. Contact your Field Application Engineer for more information on TDP specifications.
6. Implementation of this P-state is optional in BIOS.
7. Limited availability.
8. Thermal Design Power (TDP) specifications for dual core processors assume equivalent P-states (Voltage and frequency) and equivalent Tcase conditions for both cores. Refer to the BIOS and Kernel Developer's Guide for AMD Athlon™ 64 and AMD Opteron™ Processors, order# 26094, for details on P-state operation for dual core processors.

1.2 AMD Opteron™ Processor Thermal/Power Specifications

The tables in this section contain the power and thermal specifications for this processor family. Each column in the thermal/power specification tables represents a specific Ordering Part Number (OPN). Section 1.1 provides an example of the OPN structure for this processor family.

Table 13: AMD Opteron™ Processor Thermal/Power Specifications - Rev B3

Parameter/OPN	Notes	OSA140CCO5AG			OSA142CCO5AG			OSA144CCO5AG		
		OSA240CCO5AH			OSA242CCO5AH			OSA244CCO5AH		
		OSA840CCO5AI			OSA842CCO5AI			OSA844CCO5AI		
Model Number		140	240	840	142	242	842	144	244	844
L2 Cache Size		1 MB			1 MB			1 MB		
Tcase Max	1	69°C			69°C			69°C		
Tcontrol Max	3	N/A			N/A			N/A		
Tambient		42°C			42°C			42°C		
Max Frequency		1400 MHz			1600 MHz			1800 MHz		
VID_VDD	4	1.550 V			1.550 V			1.550 V		
IDD Max		52.0 A			52.0 A			52.0 A		
Thermal Design Power	5	84.7 W			84.7 W			84.7 W		
Thermal Resistance (case to ambient)		0.32°C/W			0.32°C/W			0.32°C/W		
Halt/Stop Grant	7									
IDDC1 Max		39.7 A			39.7 A			39.7 A		
I/O Power	10	4.1 W			4.1 W			4.1 W		
S3	9									
I/O Power	9, 11	1.4 W			1.4 W			1.4 W		

The notes for this table appear on page 44.

Table 14: AMD Opteron™ Processor Thermal/Power Specifications - Rev C0

Parameter/OPN	Notes	OSA140CEP5AK			OSA142CEP5AK			OSA144CEP5AK		
		OSA240CEP5AL			OSA242CEP5AL			OSA244CEP5AL		
		OSA840CEP5AM			OSA842CEP5AM			OSA844CEP5AM		
Model Number		140	240	840	142	242	842	144	244	844
L2 Cache Size		1 MB			1 MB			1 MB		
Tcase Max	1	70°C			70°C			70°C		
Tcontrol Max	3	N/A			N/A			N/A		
Tambient		42°C			42°C			42°C		
Max Frequency		1400 MHz			1600 MHz			1800 MHz		
VID_VDD	4	1.500 V			1.500 V			1.500 V		
IDD Max		52.0 A			52.0 A			52.0 A		
Thermal Design Power	5	82.1 W			82.1 W			82.1 W		
Thermal Resistance (case to ambient)		0.34°C/W			0.34°C/W			0.34°C/W		
Halt/Stop Grant	7									
IDDC1 Max		32.5 A			32.5 A			32.5 A		
I/O Power	10	4.1 W			4.1 W			4.1 W		
S3	9									
I/O Power	9, 11	1.4 W			1.4 W			1.4 W		

The notes for this table appear on page 44.

Parameter/OPN	Notes	OSA146CEP5AK			OSA148CEP5AK		
		OSA246CEP5AL			OSA248CEP5AL		
		OSA846CEP5AM			OSA848CEP5AM		
Model Number		146	246	846	148	248	848
L2 Cache Size		1 MB			1 MB		
Tcase Max	1	70°C			70°C		
Tcontrol Max	3	N/A			70°C		
Tambient		42°C			42°C		
Max Frequency		2000 MHz			2200 MHz		
VID_VDD	4	1.500 V			1.500 V		
IDD Max		56.5 A			56.5 A		
Thermal Design Power	5	89.0 W			89.0 W		
Thermal Resistance (case to ambient)		0.31°C/W			0.31°C/W		
Halt/Stop Grant	7						
IDDC1 Max		32.5 A			32.5 A		
I/O Power	10	4.1 W			4.1 W		
S3	9						
I/O Power	9, 11	1.4 W			1.4 W		

The notes for this table appear on page 44.

Table 15: AMD Opteron™ Processor Thermal/Power Specifications - Rev CG

Parameter/OPN	Notes	OSA140CEP5AT	OSA142CEP5AT	OSA144CEP5AT
		OSA240CEP5AU	OSA242CEP5AU	OSA244CEP5AU
		OSA840CEP5AV	OSA842CEP5AV	OSA844CEP5AV
Tcase Max	1	70°C	70°C	70°C
Tcontrol Max	3	70°C	70°C	70°C
Tambient		42°C	42°C	42°C
Thermal Resistance (case to ambient)		0.34°C/W	0.34°C/W	0.34°C/W
Max P-State		1400 MHz	1600 MHz	1800 MHz
VID_VDD	4	1.500 V	1.500 V	1.500 V
IDDC Max		52.0 A	52.0 A	52.0 A
Thermal Design Power	5	82.1 W	82.1 W	82.1 W
Intermediate P-State #1	12	N/A	N/A	N/A
VID_VDD	4			
IDDC Max				
Thermal Design Power	5			
Intermediate P-State #2	12	N/A	N/A	N/A
VID_VDD	4			
IDDC Max				
Thermal Design Power	5			
Intermediate P-State #3	12	N/A	N/A	N/A
VID_VDD	4			
IDDC Max				
Thermal Design Power	5			
Min P-State		N/A	N/A	1000 MHz
VID_VDD	4			1.200 V
IDDC Max				19.9 A
Thermal Design Power	5			28.0 W
Halt/Stop Grant				
IDDC1 Max @ Max P-State	7	32.5 A	32.5 A	32.5 A
IDDC1 Max @ Min P-State	8	N/A	N/A	8.2 A
I/O Power	10	4.1 W	4.1 W	4.1 W
S3	9			
I/O Power	9, 11	750 mW	750 mW	750 mW

The notes for this table appear on page 44.

Parameter/OPN	Notes	OSA146CEP5AT	OSA148CEP5AT	OSA150CEP5AT
		OSA246CEP5AU	OSA248CEP5AU	OSA250CEP5AU
		OSA846CEP5AV	OSA848CEP5AV	OSA850CEP5AV
Tcase Max	1	70°C	70°C	70°C
Tcontrol Max	3	70°C	70°C	70°C
Tambient		42°C	42°C	42°C
Thermal Resistance (case to ambient)		0.31°C/W	0.31°C/W	0.31°C/W
Max P-State		2000 MHz	2200 MHz	2400 MHz
VID_VDD	4	1.500 V	1.500 V	1.500 V
IDD Max		56.5 A	56.5 A	56.5 A
Thermal Design Power	5	89.0 W	89.0 W	89.0 W
Intermediate P-State #1	12	1800 MHz	2000 MHz	2200 MHz
VID_VDD	4	1.400 V	1.400 V	1.400 V
IDD Max		44.2 A	47.1 A	56.4 A
Thermal Design Power	5	66.0 W	70.0 W	83.0 W
Intermediate P-State #2	12	N/A	1800 MHz	2000 MHz
VID_VDD	4		1.300 V	1.300 V
IDD Max			33.0 A	39.2 A
Thermal Design Power	5		47.0 W	55.0 W
Intermediate P-State #3	12	N/A	N/A	1800 MHz
VID_VDD	4			1.250 V
IDD Max				30.3 A
Thermal Design Power	5			42.0 W
Min P-State		1000 MHz	1000 MHz	1000 MHz
VID_VDD	4	1.200 V	1.200 V	1.200 V
IDD Max		19.9 A	19.9 A	19.9 A
Thermal Design Power	5	28.0 W	28.0 W	28.0 W
Halt/Stop Grant				
IDDC1 Max @ Max P-State	7	32.5 A	32.5 A	32.5 A
IDDC1 Max @ Min P-State	8	8.2 A	8.2 A	8.2 A
I/O Power	10	4.1 W	4.1 W	4.1 W
S3	9			
I/O Power	9, 11	750 mW	750 mW	750 mW

The notes for this table appear on page 44.

Parameter/OPN	Notes	OSK146CMP5AT OSK246CMP5AU OSK846CMP5AV		
Model Number		146	246	846
L2 Cache Size		1 MB		
Tcase Max	1	70°C		
Tcontrol Max	3	70°C		
Tambient		42°C		
Max Frequency		2000 MHz		
VID_VDD	4	1.300 V		
IDD Max		39.2 A		
Thermal Design Power	5	55.0 W		
Thermal Resistance (case to ambient)		0.50°C/W		
Halt/Stop Grant	7			
IDDC1 Max		19.0 A		
I/O Power	10	4.1 W		
S3	9			
I/O Power	9, 11	750 mW		

The notes for this table appear on page 44.

Parameter/OPN	Notes	OSB140CSP5AT OSB240CSP5AU OSB840CSP5AV		
Model Number		140	240	840
L2 Cache Size		1 MB		
Tcase Max	1	70°C		
Tcontrol Max	3	70°C		
Tambient		42°C		
Max Frequency		1400 MHz		
VID_VDD	4	1.150 V		
IDD Max		22.5 A		
Thermal Design Power	5	30.0 W		
Thermal Resistance (case to ambient)		0.92°C/W		
Halt/Stop Grant	7			
IDDC1 Max		13.0 A		
I/O Power	10	4.1 W		
S3	9			
I/O Power	9, 11	750 mW		

The notes for this table appear on page 44.

Table 16: AMD Opteron™ Processor Thermal/Power Specifications - Rev E Single-Core

Parameter/OPN	Notes	OSA152FAA5BK OSA252FAA5BL OSA852FAA5BM	OSA254FAA5BL OSA854FAA5BM
Tcase Max	1, 2	49°C to 67°C	49°C to 67°C
Tcontrol Max	3	70°C	70°C
Tambient		42°C	42°C
Thermal Resistance (case to ambient)		0.27°C/W	0.27°C/W
Thermal Profile	6	B	B
Max P-State		2600 MHz	2800 MHz
VID_VDD	4	1.350 V 1.400 V	1.350 V 1.400 V
IDDC Max	6	66.1 A	66.1 A
Thermal Design Power	5, 6	92.6 W	92.6 W
Intermediate P-State #1	12	2400 MHz	2600 MHz
VID_VDD	4	1.350 V	1.350 V
IDDC Max		64.2 A	64.4 A
Thermal Design Power	5	90.0 W	90.2 W
Intermediate P-State #2	12	2200 MHz	2400 MHz
VID_VDD	4	1.300 V	1.300 V
IDDC Max		56.4 A	56.7 A
Thermal Design Power	5	76.6 W	77.0 W
Intermediate P-State #3	12	2000 MHz	2200 MHz
VID_VDD	4	1.250 V	1.250 V
IDDC Max		49.4 A	49.9 A
Thermal Design Power	5	65.1 W	65.7 W
Intermediate P-State #4	12	1800 MHz	2000 MHz
VID_VDD	4	1.200 V	1.200 V
IDDC Max		43.3 A	43.8 A
Thermal Design Power	5	55.2 W	55.9 W
Intermediate P-State #5	12	N/A	1800 MHz
VID_VDD	4		1.150 V
IDDC Max			38.5 A
Thermal Design Power	5		47.6 W
Intermediate P-State #6	12	N/A	N/A
VID_VDD	4		
IDDC Max			
Thermal Design Power	5		
Min P-State		1000 MHz	1000 MHz
VID_VDD	4	1.100 V	1.100 V
IDDC Max		26.1 A	29.8 A
Thermal Design Power	5	32.0 W	36.1 W
Halt/Stop Grant			
IDDC1 Max @ Max P-State	7	38.1 A	38.1 A
IDDC1 Max @ Min P-State	8	7.8 A	7.8 A
I/O Power	10	3.3 W	3.3 W
S3	9		
I/O Power	9, 11	750 mW	750 mW

The notes for this table appear on page 44.

Parameter/OPN	Notes	OSA242FAA5BL	OSA244FAA5BL	OSA246FAA5BL
		OSA842FAA5BM	OSA844FAA5BM	OSA846FAA5BM
Tcase Max	1, 2	49°C to 71°C	49°C to 71°C	49°C to 71°C
Tcontrol Max	3	70°C	70°C	70°C
Tambient		42°C	42°C	42°C
Thermal Resistance (case to ambient)		0.34°C/W	0.34°C/W	0.34°C/W
Thermal Profile	6	A	A	A
Max P-State		1600 MHz	1800 MHz	2000 MHz
VID_VDD	4	1.350 V 1.400 V	1.350 V 1.400 V	1.350 V 1.400 V
IDDC Max	6	60.0 A	60.0 A	60.0 A
Thermal Design Power	5, 6	85.3 W	85.3 W	85.3 W
Intermediate P-State #1	12	N/A	N/A	1800 MHz
VID_VDD	4			1.350 V
IDDC Max				58.8 A
Thermal Design Power	5			82.7 W
Intermediate P-State #2	12	N/A	N/A	N/A
VID_VDD	4			
IDDC Max				
Thermal Design Power	5			
Intermediate P-State #3	12	N/A	N/A	N/A
VID_VDD	4			
IDDC Max				
Thermal Design Power	5			
Intermediate P-State #4	12	N/A	N/A	N/A
VID_VDD	4			
IDDC Max				
Thermal Design Power	5			
Intermediate P-State #5	12	N/A	N/A	N/A
VID_VDD	4			
IDDC Max				
Thermal Design Power	5			
Intermediate P-State #6	12	N/A	N/A	N/A
VID_VDD	4			
IDDC Max				
Thermal Design Power	5			
Min P-State		N/A	1000 MHz	1000 MHz
VID_VDD	4		1.100 V	1.100 V
IDDC Max			31.4 A	30.3 A
Thermal Design Power	5		37.8 W	36.6 W
Halt/Stop Grant				
IDDC1 Max @ Max P-State	7	35.1 A	35.1 A	35.1 A
IDDC1 Max @ Min P-State	8	N/A	7.5 A	7.5 A
I/O Power	10	3.3 W	3.3 W	3.3 W
S3	9			
I/O Power	9, 11	750 mW	750 mW	750 mW

The notes for this table appear on page 44.

Parameter/OPN	Notes	OSA248FAA5BL OSA848FAA5BM	OSA250FAA5BL OSA850FAA5BM
Tcase Max	1, 2	49°C to 71°C	49°C to 71°C
Tcontrol Max	3	70°C	70°C
Tambient		42°C	42°C
Thermal Resistance (case to ambient)		0.34°C/W	0.34°C/W
Thermal Profile		A	A
Max P-State		2200 MHz	2400 MHz
VID_VDD	4	1.350 V 1.400 V	1.350 V 1.400 V
IDD Max	6	60.0 A	60.0 A
Thermal Design Power	5, 6	85.3 W	85.3 W
Intermediate P-State #1	12	2000 MHz	2200 MHz
VID_VDD	4	1.350 V	1.350 V
IDD Max		58.8 A	58.8 A
Thermal Design Power	5	82.7 W	82.7 W
Intermediate P-State #2	12	1800 MHz	2000 MHz
VID_VDD	4	1.300 V	1.300 V
IDD Max		51.3 A	51.5 A
Thermal Design Power	5	70.0 W	70.2 W
Intermediate P-State #3	12	N/A	1800 MHz
VID_VDD	4		1.250 V
IDD Max			45.0 A
Thermal Design Power	5		59.5 W
Intermediate P-State #4	12	N/A	N/A
VID_VDD	4		
IDD Max			
Thermal Design Power	5		
Intermediate P-State #5	12	N/A	N/A
VID_VDD	4		
IDD Max			
Thermal Design Power	5		
Intermediate P-State #6	12	N/A	N/A
VID_VDD	4		
IDD Max			
Thermal Design Power	5		
Min P-State		1000 MHz	1000 MHz
VID_VDD	4	1.100 V	1.100 V
IDD Max		30.3 A	24.4 A
Thermal Design Power	5	36.6 W	30.1 W
Halt/Stop Grant			
IDDC1 Max @ Max P-State	7	35.1 A	35.1 A
IDDC1 Max @ Min P-State	8	7.5 A	7.5 A
I/O Power	10	3.3 W	3.3 W
S3	9		
I/O Power	9, 11	750 mW	750 mW

The notes for this table appear on page 44.

Parameter/OPN	Notes	OSK246FAA5BL OSK846FAA5BM	OSK848FAA5BM	OSK250FAA5BL OSK850FAA5BM
Tcase Max	1, 2	49°C to 71°C	49°C to 71°C	49°C to 71°C
Tcontrol Max	3	70°C	70°C	70°C
Tambient		42°C	42°C	42°C
Thermal Resistance (case to ambient)		0.53°C/W	0.53°C/W	0.53°C/W
Thermal Profile	6	C	C	C
Max P-State		2000 MHz	2200 MHz	2400 MHz
VID_VDD	4	1.350 V 1.400 V	1.350 V 1.400 V	1.350 V 1.400 V
IDD Max	6	38.1 A	38.1 A	38.1 A
Thermal Design Power	5, 6	54.7 W	54.7 W	54.7 W
Intermediate P-State #1	12	1800 MHz	2000 MHz	2200 MHz
VID_VDD	4	1.350 V	1.350 V	1.350 V
IDD Max		31.7 A	36.1 A	36.1 A
Thermal Design Power	5	46.1 W	52.1 W	52.1 W
Intermediate P-State #2	12	N/A	1800 MHz	2000 MHz
VID_VDD	4		1.300 V	1.300 V
IDD Max			32.8 A	31.3 A
Thermal Design Power	5		45.9 W	44.0 W
Intermediate P-State #3	12	N/A	N/A	1800 MHz
VID_VDD	4			1.250 V
IDD Max				27.7 A
Thermal Design Power	5			37.9 W
Intermediate P-State #4	12	N/A	N/A	N/A
VID_VDD	4			
IDD Max				
Thermal Design Power	5			
Intermediate P-State #5	12	N/A	N/A	N/A
VID_VDD	4			
IDD Max				
Thermal Design Power	5			
Intermediate P-State #6	12	N/A	N/A	N/A
VID_VDD	4			
IDD Max				
Thermal Design Power	5			
Min P-State		1000 MHz	1000 MHz	1000 MHz
VID_VDD	4	1.100 V	1.100 V	1.100 V
IDD Max		17.3 A	16.2 A	15.1 A
Thermal Design Power	5	22.3 W	21.1 W	19.9 W
Halt/Stop Grant				
IDDC1 Max @ Max P-State	7	19.3 A	19.3 A	19.3 A
IDDC1 Max @ Min P-State	8	4.2 A	4.2 A	4.2 A
I/O Power	10	3.3 W	3.3 W	3.3 W
S3	9			
I/O Power	9, 11	750 mW	750 mW	750 mW

The notes for this table appear on page 44.

Parameter/OPN	Notes	OSA144DAA5BN	OSA148DAA5BN
Tcase Max	1, 2	49°C to 71°C	49°C to 71°C
Tcontrol Max	3	70°C	70°C
Tambient		42°C	42°C
Thermal Resistance (case to ambient)		0.34°C/W	0.34°C/W
Thermal Profile	6	D	A
Max P-State		1800 MHz	2200 MHz
VID_VDD	4	1.350 V 1.400 V	1.350 V 1.400 V
IDD Max	6	47.5 A	60.0 A
Thermal Design Power	5, 6	67.0 W	85.3 W
Intermediate P-State #1	12	N/A	2000 MHz
VID_VDD	4		1.350 V
IDD Max			59.3 A
Thermal Design Power	5		83.0 W
Intermediate P-State #2	12	N/A	1800 MHz
VID_VDD	4		1.300 V
IDD Max			51.9 A
Thermal Design Power	5		70.4 W
Intermediate P-State #3	12	N/A	N/A
VID_VDD	4		
IDD Max			
Thermal Design Power	5		
Intermediate P-State #4	12	N/A	N/A
VID_VDD	4		
IDD Max			
Thermal Design Power	5		
Intermediate P-State #5	12	N/A	N/A
VID_VDD	4		
IDD Max			
Thermal Design Power	5		
Intermediate P-State #6	12	N/A	N/A
VID_VDD	4		
IDD Max			
Thermal Design Power	5		
Min P-State		1000 MHz	1000 MHz
VID_VDD	4	1.100 V	1.100 V
IDD Max		24.3 A	30.2 A
Thermal Design Power	5	29.6 W	36.1 W
Halt/Stop Grant			
IDDC1 Max @ Max P-State	7	19.3 A	34.8 A
IDDC1 Max @ Min P-State	8	4.2 A	7.1 A
I/O Power	10	2.9 W	2.9 W
S3	9		
I/O Power	9, 11	500 mW	500 mW

The notes for this table appear on page 44.

Parameter/OPN	Notes	OSA152DAA5BN
Tcase Max	1, 2	49°C to 65°C
Tcontrol Max	3	70°C
Tambient		42°C
Thermal Resistance (case to ambient)		0.22°C/W
Thermal Profile	6	H
Max P-State		2600 MHz
VID_VDD	4	1.350 V 1.400 V
IDD Max	6	74.9 A
Thermal Design Power	5, 6	104.0 W
Intermediate P-State #1	12	2400 MHz
VID_VDD	4	1.350 V
IDD Max		73.1 A
Thermal Design Power	5	101.6 W
Intermediate P-State #2	12	2200 MHz
VID_VDD	4	1.300 V
IDD Max		64.2 A
Thermal Design Power	5	86.3 W
Intermediate P-State #3	12	2000 MHz
VID_VDD	4	1.250 V
IDD Max		56.2 A
Thermal Design Power	5	73.2 W
Intermediate P-State #4	12	1800 MHz
VID_VDD	4	1.200 V
IDD Max		49.3 A
Thermal Design Power	5	62.1 W
Intermediate P-State #5	12	N/A
VID_VDD	4	
IDD Max		
Thermal Design Power	5	
Intermediate P-State #6	12	N/A
VID_VDD	4	
IDD Max		
Thermal Design Power	5	
Min P-State		1000 MHz
VID_VDD	4	1.100 V
IDD Max		35.5 A
Thermal Design Power	5	41.9 W
Halt/Stop Grant		
IDDC1 Max @ Max P-State	7	38.1 A
IDDC1 Max @ Min P-State	8	7.8 A
I/O Power	10	2.9 W
S3	9	
I/O Power	9, 11	500 mW

The notes for this table appear on page 44.

Parameter/OPN	Notes	OSA146DAA5BN	OSA150DAA5BN	OSA154DAA5BN
Tcase Max	1, 2	49°C to 65°C	49°C to 71°C	49°C to 65°C
Tcontrol Max	3	70°C	70°C	70°C
Tambient		42°C	42°C	42°C
Thermal Resistance (case to ambient)		0.34°C/W	0.34°C/W	0.22°C/W
Thermal Profile	6	D	A	H
Max P-State		2000 MHz	2400 MHz	2800 MHz
VID_VDD	4	1.350 V 1.400 V	1.350 V 1.400 V	1.350 V 1.400 V
IDD Max	6	47.5 A	60.0 A	74.9 A
Thermal Design Power	5, 6	67.0 W	85.3 W	104.0 W
Intermediate P-State #1	12	1800 MHz	2200 MHz	2600 MHz
VID_VDD	4	1.350 V	1.350 V	1.350 V
IDD Max		45.8 A	59.3 A	73.2 A
Thermal Design Power	5	64.7 W	83.0 W	101.7 W
Intermediate P-State #2	12	N/A	2000 MHz	2400 MHz
VID_VDD	4		1.300 V	1.300 V
IDD Max			52.1 A	64.5 A
Thermal Design Power	5		70.6 W	86.8 W
Intermediate P-State #3	12	N/A	1800 MHz	2200 MHz
VID_VDD	4		1.250 V	1.250 V
IDD Max			45.4 A	56.9 A
Thermal Design Power	5		59.6 W	74.0 W
Intermediate P-State #4	12	N/A	N/A	2000 MHz
VID_VDD	4			1.200 V
IDD Max				50.1 A
Thermal Design Power	5			63.0 W
Intermediate P-State #5	12	N/A	N/A	1800 MHz
VID_VDD	4			1.150 V
IDD Max				44.2 A
Thermal Design Power	5			53.7 W
Intermediate P-State #6	12	N/A	N/A	N/A
VID_VDD	4			
IDD Max				
Thermal Design Power	5			
Min P-State		1000 MHz	1000 MHz	1000 MHz
VID_VDD	4	1.100 V	1.100 V	1.100 V
IDD Max		23.4 A	29.2 A	35.2 A
Thermal Design Power	5	28.6 W	35.0 W	41.6 W
Halt/Stop Grant				
IDDC1 Max @ Max P-State	7	19.3 A	34.8 A	48.0 A
IDDC1 Max @ Min P-State	8	4.2 A	7.1 A	9.7 A
I/O Power	10	2.9 W	2.9 W	2.9 W
S3	9			
I/O Power	9, 11	500 mW	500 mW	500 mW

The notes for this table appear on page 44.

Table 17: AMD Opteron™ Processor Thermal/Power Specifications - Rev E Dual-Core

Parameter/OPN	Notes	OSA865FAA6CC	OSA870FAA6CC	OSA875FAA6CC
Tcase Max	1, 2	49°C to 67°C	49°C to 67°C	49°C to 67°C
Tcontrol Max	3	70°C	70°C	70°C
Tambient		42°C	42°C	42°C
Thermal Resistance (case to ambient)		0.25°C/W	0.25°C/W	0.25°C/W
Thermal Profile	6	F	F	F
Max P-State		1800 MHz	2000 MHz	2200 MHz
VID_VDD	4	1.300 V 1.350 V	1.300 V 1.350 V	1.300 V 1.350 V
IDD Max	6	70.5 A	70.5 A	70.5 A
Thermal Design Power	5, 6, 14	95.0 W	95.0 W	95.0 W
Intermediate P-State #1	12	N/A	1800 MHz	2000 MHz
VID_VDD	4		1.300 V	1.300 V
IDD Max			66.9 A	66.9 A
Thermal Design Power	5, 14		90.3 W	90.3 W
Intermediate P-State #2	12	N/A	N/A	1800 MHz
VID_VDD	4			1.250 V
IDD Max				58.1 A
Thermal Design Power	5, 14			75.9 W
Intermediate P-State #3	12	N/A	N/A	N/A
VID_VDD	4			
IDD Max				
Thermal Design Power	5, 14			
Intermediate P-State #4	12	N/A	N/A	N/A
VID_VDD	4			
IDD Max				
Thermal Design Power	5, 14			
Intermediate P-State #5	12	N/A	N/A	N/A
VID_VDD	4			
IDD Max				
Thermal Design Power	5			
Intermediate P-State #6	12	N/A	N/A	N/A
VID_VDD	4			
IDD Max				
Thermal Design Power	5, 14			
Min P-State		1000 MHz	1000 MHz	1000 MHz
VID_VDD	4	1.100 V	1.100 V	1.100 V
IDD Max		33.9 A	31.8 A	29.8 A
Thermal Design Power	5, 14	40.6 W	38.3 W	36.1 W
Halt/Stop Grant				
IDDC1 Max @ Max P-State	7, 15	37.7 A	37.7 A	37.7 A
IDDC1 Max @ Min P-State	8, 15	9.3 A	9.3 A	9.3 A
I/O Power	10	3.3 W	3.3 W	3.3 W
S3	9			
I/O Power	9, 11	750 mW	750 mW	750 mW

The notes for this table appear on page 44.

Parameter/OPN	Notes	OSA280FAA6CB OSA880FAA6CC
Tcase Max	1, 2	49°C to 67°C
Tcontrol Max	3	70°C
Tambient	0	42°C
Thermal Resistance (case to ambient)	0	0.25°C/W
Thermal Profile		F
Max P-State	0	2400 MHz
VID_VDD	4	1.300 V 1.350 V
IDD Max	6	70.5 A
Thermal Design Power	5, 6, 14	95.0 W
Intermediate P-State #1	12	2200 MHz
VID_VDD	4	1.300 V
IDD Max	0	66.9 A
Thermal Design Power	5, 14	90.3 W
Intermediate P-State #2	12	2000 MHz
VID_VDD	4	1.250 V
IDD Max	0	58.2 A
Thermal Design Power	5, 14	76.1 W
Intermediate P-State #3	12	1800 MHz
VID_VDD	4	1.200 V
IDD Max	0	50.3 A
Thermal Design Power	5, 14	63.7 W
Intermediate P-State #4	12	N/A
VID_VDD	4	
IDD Max	0	
Thermal Design Power	5, 14	
Intermediate P-State #5	12	N/A
VID_VDD	4	
IDD Max	0	
Thermal Design Power	5	
Intermediate P-State #6	12	N/A
VID_VDD	4	
IDD Max	0	
Thermal Design Power	5, 14	
Min P-State	0	1000 MHz
VID_VDD	4	1.100 V
IDD Max	0	29.8 A
Thermal Design Power	5, 14	36.1 W
Halt/Stop Grant	0	
IDDCl Max @ Max P-State	7, 15	37.7 A
IDDCl Max @ Min P-State	8, 15	9.3 A
I/O Power	10	3.3 W
S3	9	
I/O Power	9, 11	750 mW

The notes for this table appear on page 44.

Parameter/OPN	Notes	OSA165DAA6CD	OSA170DAA6CD	OSA175DAA6CD
Tcase Max	1, 2	49°C to 65°C	49°C to 65°C	49°C to 65°C
Tcontrol Max	3	70°C	70°C	70°C
Tambient		42°C	42°C	42°C
Thermal Resistance (case to ambient)		0.20°C/W	0.20°C/W	0.20°C/W
Thermal Profile	6	I	I	I
Max P-State		1800 MHz	2000 MHz	2200 MHz
VID_VDD	4	1.300 V 1.350 V	1.300 V 1.350 V	1.300 V 1.350 V
IDD Max	6	80.0 A	80.0 A	80.0 A
Thermal Design Power	5, 6, 14	110.0 W	110.0 W	110.0 W
Intermediate P-State #1	12	N/A	1800 MHz	2000 MHz
VID_VDD	4		1.300 V	1.300 V
IDD Max			79.0 A	79.0 A
Thermal Design Power	5, 14		105.6 W	105.6 W
Intermediate P-State #2	12	N/A	N/A	1800 MHz
VID_VDD	4			1.250 V
IDD Max				69.0 A
Thermal Design Power	5, 14			89.1 W
Intermediate P-State #3	12	N/A	N/A	N/A
VID_VDD	4			
IDD Max				
Thermal Design Power	5, 14			
Intermediate P-State #4	12	N/A	N/A	N/A
VID_VDD	4			
IDD Max				
Thermal Design Power	5, 14			
Intermediate P-State #5	12	N/A	N/A	N/A
VID_VDD	4			
IDD Max				
Thermal Design Power	5			
Intermediate P-State #6	12	N/A	N/A	N/A
VID_VDD	4			
IDD Max				
Thermal Design Power	5, 14			
Min P-State		1000 MHz	1000 MHz	1000 MHz
VID_VDD	4	1.100 V	1.100 V	1.100 V
IDD Max		44.3 A	44.3 A	41.9 A
Thermal Design Power	5, 14	51.6 W	51.6 W	49.0 W
Halt/Stop Grant				
IDDC1 Max @ Max P-State	7, 15	44.5 A	44.5 A	44.5 A
IDDC1 Max @ Min P-State	8, 15	10.9 A	10.9 A	10.9 A
I/O Power	10	2.9 W	2.9 W	2.9 W
S3	9			
I/O Power	9, 11	500 mW	500 mW	500 mW

The notes for this table appear on page 44.

Parameter/OPN	Notes	OSK260FAA6CB OSK860FAA6CC	OSK265FAA6CB OSK865FAA6CC	OSK270FAA6CB OSK870FAA6CC
Tcase Max	1, 2	49°C to 71°C	49°C to 71°C	49°C to 71°C
Tcontrol Max	3	70°C	70°C	70°C
Tambient		42°C	42°C	42°C
Thermal Resistance (case to ambient)		0.51°C/W	0.51°C/W	0.51°C/W
Thermal Profile	6	G	G	G
Max P-State		1600 MHz	1800 MHz	2000 MHz
VID_VDD	4	1.150 V 1.200 V	1.150 V 1.200 V	1.150 V 1.200 V
IDD Max	6	45.0 A	45.0 A	45.0 A
Thermal Design Power	5, 6, 14	55.0 W	55.0 W	55.0 W
Intermediate P-State #1	12	N/A	N/A	1800 MHz
VID_VDD	4			1.150 V
IDD Max				42.3 A
Thermal Design Power	5, 6, 14			52.0 W
Intermediate P-State #2	12	N/A	N/A	N/A
VID_VDD	4			
IDD Max				
Thermal Design Power	5, 6, 14			
Intermediate P-State #3	12	N/A	N/A	N/A
VID_VDD	4			
IDD Max				
Thermal Design Power	5, 6, 14			
Intermediate P-State #4	12	N/A	N/A	N/A
VID_VDD	4			
IDD Max				
Thermal Design Power	5, 6, 14			
Intermediate P-State #5	12	N/A	N/A	N/A
VID_VDD	4			
IDD Max				
Thermal Design Power	5, 6, 14			
Intermediate P-State #6	12	N/A	N/A	N/A
VID_VDD	4			
IDD Max				
Thermal Design Power	5, 6, 14			
Min P-State		N/A	1000 MHz	1000 MHz
VID_VDD	4		1.100 V	1.100 V
IDD Max			30.2 A	27.5 A
Thermal Design Power	5, 6, 14		36.5 W	33.5 W
Halt/Stop Grant				
IDDC1 Max @ Max P-State	7, 15	30.2 A	30.2 A	30.2 A
IDDC1 Max @ Min P-State	8, 15	N/A	7.5 A	7.5 A
I/O Power	10	3.3 W	3.3 W	3.3 W
S3	9			
I/O Power	9, 11	750 mW	750 mW	750 mW

The notes for this table appear on page 44.

Parameter/OPN	Notes	OSA180DAA6CD
Tcase Max	1, 2	49°C to 65°C
Tcontrol Max	3	70°C
Tambient		42°C
Thermal Resistance (case to ambient)		0.20°C/W
Thermal Profile	6	I
Max P-State		2400 MHz
VID_VDD	4	1.300 V 1.350 V
IDD Max	6	80.0 A
Thermal Design Power	5, 6, 14	110.0 W
Intermediate P-State #1	12	2200 MHz
VID_VDD	4	1.300 V
IDD Max		79.0 A
Thermal Design Power	5, 14	105.6 W
Intermediate P-State #2	12	2000 MHz
VID_VDD	4	1.250 V
IDD Max		69.0 A
Thermal Design Power	5, 14	89.1 W
Intermediate P-State #3	12	1800 MHz
VID_VDD	4	1.200 V
IDD Max		59.9 A
Thermal Design Power	5, 14	74.8 W
Intermediate P-State #4	12	N/A
VID_VDD	4	
IDD Max		
Thermal Design Power	5, 14	
Intermediate P-State #5	12	N/A
VID_VDD	4	
IDD Max		
Thermal Design Power	5	
Intermediate P-State #6	12	N/A
VID_VDD	4	
IDD Max		
Thermal Design Power	5, 14	
Min P-State		1000 MHz
VID_VDD	4	1.100 V
IDD Max		39.7 A
Thermal Design Power	5, 14	46.6 W
Halt/Stop Grant		
IDDC1 Max @ Max P-State	7, 15	44.5 A
IDDC1 Max @ Min P-State	8, 15	10.9 A
I/O Power	10	2.9 W
S3	9	
I/O Power	9, 11	500 mW

The notes for this table appear on page 44.

Notes:

1. Tcase max is the maximum case temperature specification which is a physical value in degrees Celsius. This value is programmed into Rev D and later processors. Refer to the AMD Functional Data Sheet, 940 Pin Package, order# 31412, and the THERMTRIP Status Register in the BIOS and Kernel Developer's Guide for AMD Athlon™ 64 and AMD Opteron™ Processors, order# 26094.
2. Tcase max is programmed during device manufacturing with part-specific values for Rev E and later processors with 'Variable' indicated by the Case Temperature OPN character, and can be any valid Tcase max value in the range specified for the corresponding OPN.
3. Tcontrol max (maximum control temperature) is a non physical temperature on an arbitrary scale that can be used for system thermal management policies. Tcontrol max represents the value at which the processor has reached Tcase max when measuring the thermal diode with a dual sourcing current temperature sensor. Refer to the AMD Functional Data Sheet, 940 Pin Package, order# 31412, and the THERMTRIP Status Register in the BIOS and Kernel Developer's Guide for AMD Athlon™ 64 and AMD Opteron™ Processors, order# 26094. Temperature is in degrees Celsius on the Tcontrol scale.
4. The VID_VDD voltage is the VID[4:0] requested VDD supply level. Refer to the appropriate functional data sheet for details.
5. Thermal Design Power (TDP) is measured under the conditions of Tcase Max and VDD=VID_VDD, and include all power dissipated on-die from VDD, VDDIO, VLDT, VTT, and VDDA. Contact your Field Application Engineer for more information on TDP specifications.
6. Thermal Design Power (TDP) and IDD max for Rev E and later processors with 'Variable' indicated by the Operating Voltage and Case Temperature OPN characters are the limits at the highest Tcase max in the specified range for the corresponding OPN. Products will conform to the TDP and IDD Max limits at all valid voltages. The relationship of Tcase max and Thermal Profile to TDP for a specific device is defined in
7. Assumes Tcase max, VID_VDD, clock divider set to 32.
8. Assumes 50°C, min P-state VID_VDD, clock divider set to 32.
9. Assumes 35°C, VDD, VDDA, and VLDT supplies are off, VDDIO and VTT are powered, memory in self-refresh mode and DDR SDRAM interface tri-stated except CKE pins.
10. Thermal Design Power dissipated by the processor VDDIO, VTT, VLDT, and VDDA power planes only.
11. Thermal Design Power dissipated by the processor VDDIO, VTT planes only.
12. Implementation of this P-state is optional in BIOS.
13. Limited availability.
14. Thermal Design Power (TDP) specifications for dual core processors assume equivalent P-states (Voltage and frequency) and equivalent Tcase conditions for both cores. Refer to the BIOS and Kernel Developer's Guide for AMD Athlon™ 64 and AMD Opteron™ Processors, order# 26094, for details on P-state operation for dual core processors.
15. IDDC1 specifications for dual core processors assume equivalent Voltage, clock divisor, and Tcase conditions for both cores.

2 MTOPS

Table 18 shows the Composite Theoretical Performance (CTP) calculations ("Calculations") for AMD Opteron™ microprocessors. The Calculations are stated in Millions of Theoretical Operations Per Second (MTOPS) and are based upon a formula in the United States Department of Commerce Export Administration Regulations 15 CFR 774 (Advisory Note 4 for Category 4).

All Calculations contained herein are subject to change without notice. AMD makes no representation or warranty as to the accuracy or reliability of such Calculations.

THESE CALCULATIONS ARE PROVIDED "AS IS" WITH NO WARRANTIES WHATSOEVER, EXPRESS OR IMPLIED, INCLUDING ANY WARRANTY OF MERCHANTABILITY, NONINFRINGEMENT, FITNESS FOR ANY PARTICULAR PURPOSE OR ANY WARRANTY OTHERWISE ARISING OUT OF AMD PROVIDING OR ANY PARTY'S USE OF THE CALCULATIONS.

Furthermore, AMD shall have no liability for any losses or damages including direct, indirect, special or consequential, such as but not limited to, loss of anticipated profits or other economic loss occurring in connection with use of the Calculations. No license, express or implied, by estoppel or otherwise, to any intellectual property rights is granted herein.

Table 18: Composite Theoretical Performance (CTP) Calculations

MTOPS	Frequency	Processor	Platform			
			1P	2P	4P	8P
Single-Core	800	2,467	2,467	4,667	9,067	17,867
	1000	3,084	3,084	5,834	11,334	22,334
	1200	3,700	3,700	7,000	13,600	26,800
	1400	4,317	4,317	8,167	15,867	31,267
	1600	4,934	4,934	9,334	18,134	35,734
	1800	5,550	5,550	10,500	20,400	40,200
	2000	6,167	6,167	11,667	22,667	44,667
	2200	6,784	6,784	12,834	24,934	49,134
	2400	7,400	7,400	14,000	27,200	53,600
	2600	8,017	8,017	15,167	29,467	58,067
	2800	8,634	8,634	16,334	31,734	62,534
3000	9,250	9,250	17,500	34,000	67,000	
Dual-Core	800	4,667	4,667	9,067	17,867	35,467
	1000	5,834	5,834	11,334	22,334	44,334
	1200	7,000	7,000	13,600	26,800	53,200
	1400	8,167	8,167	15,867	31,267	62,067
	1600	9,334	9,334	18,134	35,734	70,934
	1800	10,500	10,500	20,400	40,200	79,800
	2000	11,667	11,667	22,667	44,667	88,667
	2200	12,834	12,834	24,934	49,134	97,534
	2400	14,000	14,000	27,200	53,600	106,400
	2600	15,167	15,167	29,467	58,067	115,267
	2800	16,334	16,334	31,734	62,534	124,134
3000	17,500	17,500	34,000	67,000	133,000	

X-ON Electronics

Largest Supplier of Electrical and Electronic Components

Click to view similar products for [Microprocessors - MPU category](#):

Click to view products by [Cypress manufacturer](#):

Other Similar products are found below :

[MC68302EH20C](#) [MC7457RX1000LC](#) [MC7457RX1267LC](#) [A2C00010998 A](#) [A2C52004004](#) [R5F117BCGNA#20](#) [R5F52106BDLA#U0](#)
[R5S72690W266BG#U0](#) [ADJ3400IAA5DOE](#) [MPC8245TVV266D](#) [MPC8245TZU300D](#) [MPC8260ACVVMHBB](#) [MPC8323ECVRAFDCA](#)
[MPC8536ECVJAVLA](#) [BOXNUC5PGYH0AJ](#) [20-668-0024](#) [P1010NSN5DFB](#) [P2020NXE2HHC](#) [P5020NSE7TNB](#) [P5020NSE7VNB](#)
[LS1020ASN7KQB](#) [LS1020AXN7HNB](#) [LS1020AXN7KQB](#) [A2C00010729 A](#) [A2C00039344](#) [T1022NSE7MQB](#) [T1022NXN7PQB](#)
[T1023NSE7MQA](#) [T1024NXE7PQA](#) [T1042NSN7MQB](#) [T1042NXN7WQB](#) [T2080NSN8PTB](#) [T2080NXE8TTB](#) [T2081NXN8TTB](#)
[R5F101AFASP#V0](#) [MC68302CEH20C](#) [TS68040MF33A](#) [MPC8260ACVVMIBB](#) [MPC8280CZUUPEA](#) [MPC8313ECVRAFFC](#)
[MPC8313ECVRAGDC](#) [MPC8313EVRADDC](#) [MPC8313EVRAFFC](#) [MPC8313VRADDC](#) [MPC8323EVRAFDCA](#) [BOXSTCK1A8LFCL](#)
[UPD78F0503AMCA-CAB-G](#) [UPD78F0513AGA-8EU-AT](#) [UPD78F0730MC-CAB-AX](#) [DF2134BFA20V](#)