



Please note that Cypress is an Infineon Technologies Company.

The document following this cover page is marked as “Cypress” document as this is the company that originally developed the product. Please note that Infineon will continue to offer the product to new and existing customers as part of the Infineon product portfolio.

Continuity of document content

The fact that Infineon offers the following product as part of the Infineon product portfolio does not lead to any changes to this document. Future revisions will occur when appropriate, and any changes will be set out on the document history page.

Continuity of ordering part numbers

Infineon continues to support existing part numbers. Please continue to use the ordering part numbers listed in the datasheet for ordering.

ASSP CXPI Transceiver IC for Automotive Network

The S6BT112A01 and S6BT112A02 are integrated transceiver ICs for automotive communication network with Clock Extension Peripheral Interface (CXPI). It has a flexible bit rate ranging from 2.4 kbps to 20 kbps and is JASO CXPI compliant. This CXPI transceiver IC connects the CXPI data link controller and the CXPI Bus line, and enables direct connection to the vehicle battery with a high surge protection. Additionally, S6BT112A01 have an optional Spread Spectrum Clock Generator (SSCG) function, which is effective at master node. During Sleep mode, S6BT112A01 and S6BT112A02 reduce power consumption. The CXPI transceiver IC supports master node and slave node, which is set by SELMS pins.

Features

- Compliant with the JASO CXPI (JASO D 015-3: 2015) standard
- Compliant with the SAE CXPI (J3076_201510) standard
- Supports 2.4 kbps to 20 kbps bitrate
- Waveshaping for low Electromagnetic Interference (EMI)
- Operating voltage range: 5.3 V to 18 V
- Direct battery operation with protection against load dump, jump start, and transients
- BUS short to V_{BAT} overcurrent protection
- Loss of ground protection; BUS pin leakage is lower than ±1 mA
- Easy selection of master node or slave node
- Overtemperature protection
- Low-voltage detection
- Supports Sleep and Wakeup modes
- Sleep mode current: 6 μA (typical at Slave)
- Halogen-free 8-pin SOIC package
- ESD protection HBM (1.5 kΩ, 100 pF) ±8 kV (BUS pin, BAT pin)
- Voltage tolerance ±40 V (BUS pin)
- S6BT112A01: With SSCG
S6BT112A02: Without SSCG
- AEC-Q100 compliant (Grade-1)
- Application Notes: [AN227376](#) - Getting Started with CXPI Transceiver S6BT112A

S6BT112A Block Diagram

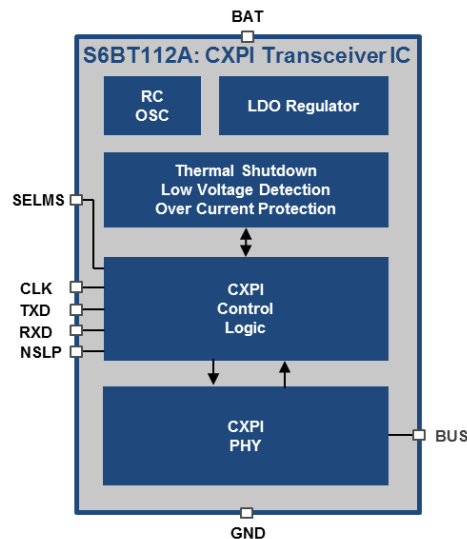

Table of Contents

1. Applications	3
2. Pin Assignment	4
3. Pin Descriptions	5
4. Block Diagram	6
5. Function Description	7
5.1 Operation Modes	7
5.2 Master Node	8
5.3 Slave Node	11
5.4 Common Functions	15
6. Absolute Maximum Ratings	21
7. Recommended Operating Conditions	22
8. Electrical Characteristics	23
9. Ordering Information	34
10. Package Dimensions	34
Document History	35
Sales, Solutions, and Legal Information	37

1. Applications

Figure 1-1 and Figure 1-2 illustrate the typical applications of S6BT112A01 or S6BT112A02.

Figure 1-1 Typical Application as Master

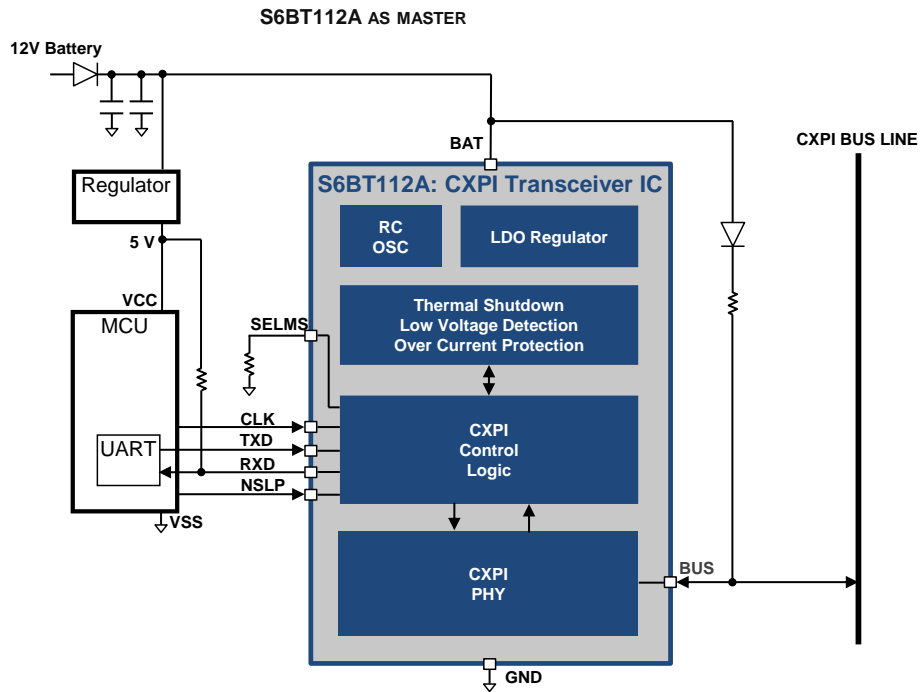
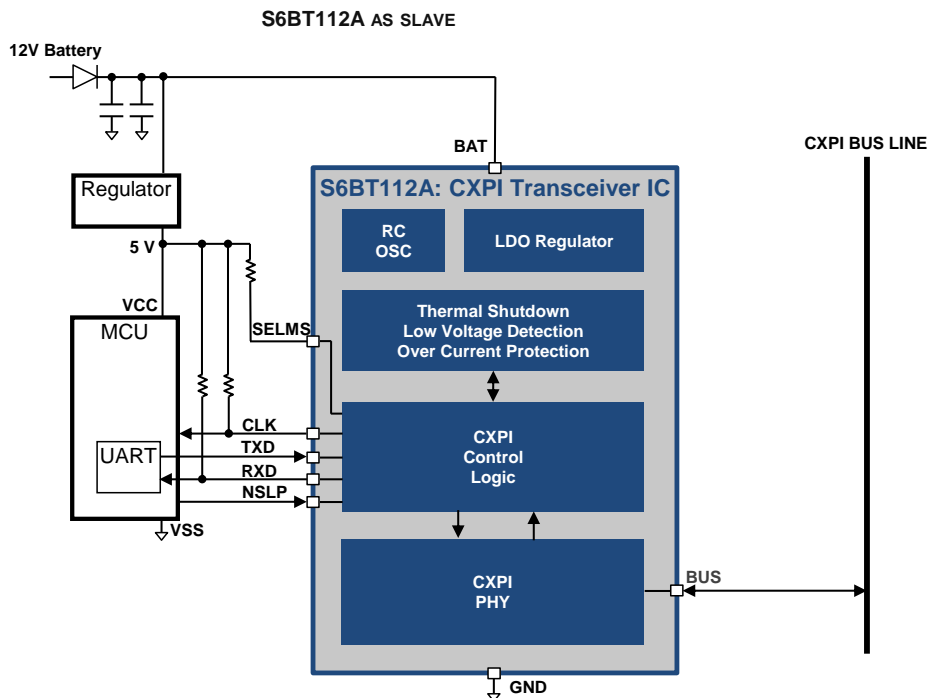
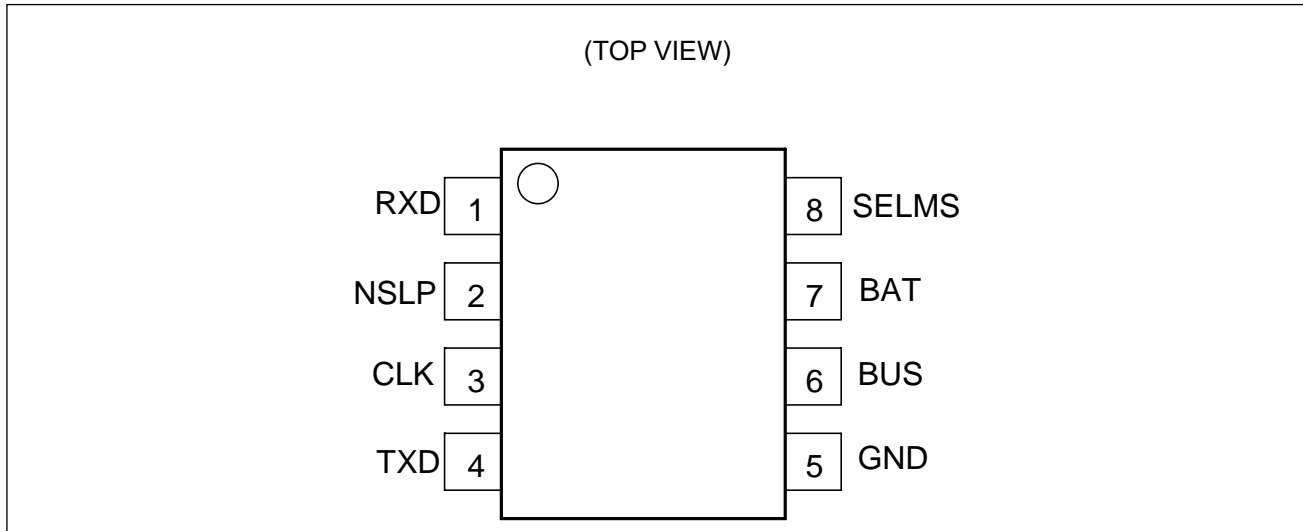

Figure 1-2 Typical Application as Slave



2. Pin Assignment

Figure 2-1. Pin Assignment



3. Pin Descriptions

Table 3-1. Pin Descriptions

Pin Number	Symbol	Direction	Description
1	RXD	Output	Receive data output (open-drain) Requires external pull-up resistor (refer to Table 7-1)
2	NSLP	Input	Sleep control input Low: Sleep mode High: Normal mode or Standby mode Refer to section 5.2.2 or section 5.3.2
3	CLK	I/O	When the SELMS pin is low level, the CLK pin is the baud rate clock input Input clock signal with baud rate frequency (When the input clock frequency is 20 kHz, the bit rate is 20 kbps) When the SELMS pin is high level, the CLK pin is baud rate clock output Outputs clock signal with baud rate frequency (When the output clock frequency is 20 kHz, the bit rate is 20 kbps) Open drain output Requires external pull-up resistor (refer to Table 7-1)
4	TXD	Input	Transmit data input
5	GND	-	Ground
6	BUS	I/O	CXPI BUS line Input/Output
7	BAT	-	Battery (voltage source) supply
8	SELMS	Input	Master / slave node select input Low: Master High: Slave

5. Function Description

5.1 Operation Modes

Figure 5-1. State Transition Diagram

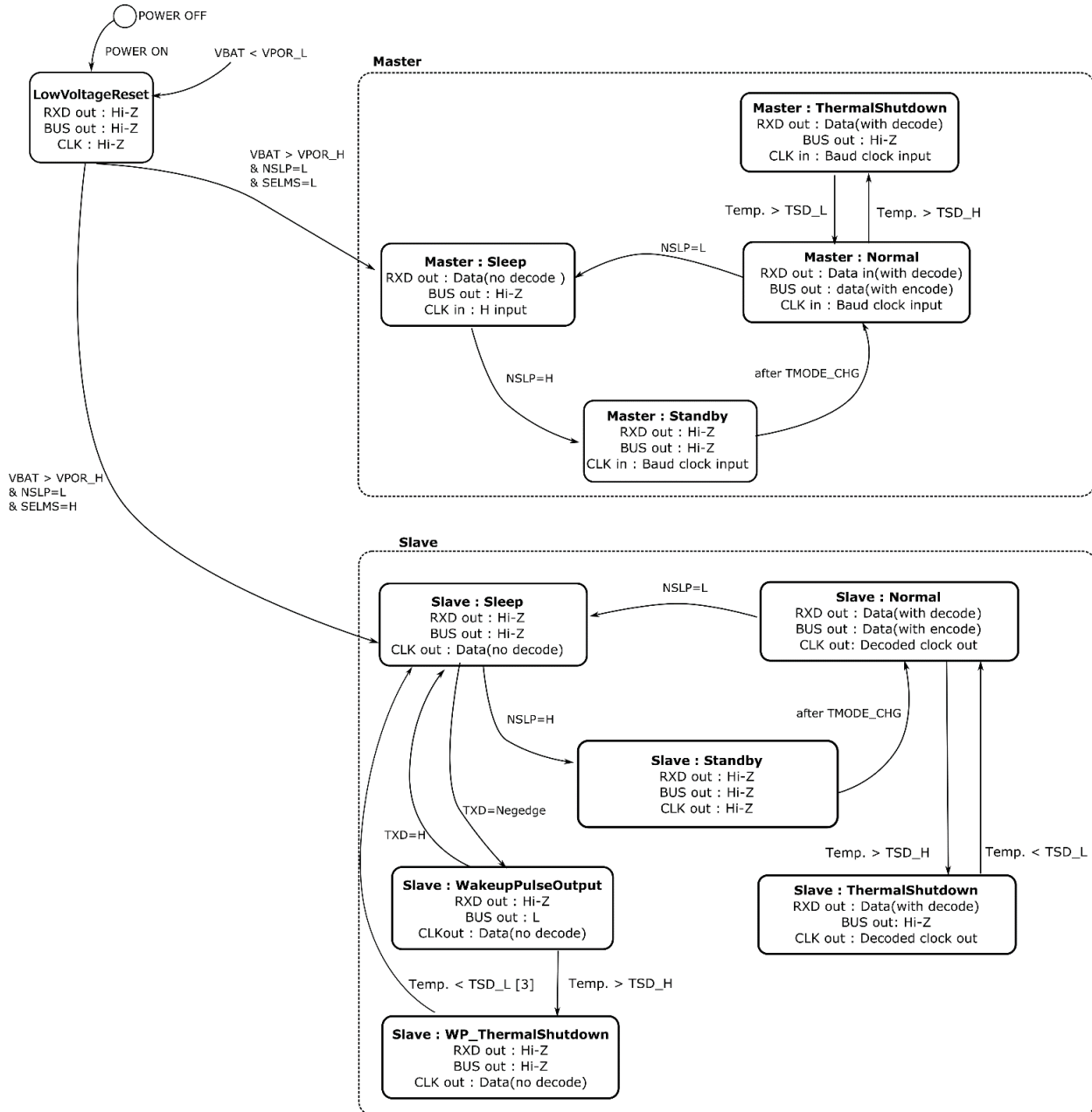

Notes

- [1] : "Hi-z" means high-impedance.
- [2] : Switching of the master / slave during transmitting is prohibited. Refer to section 5.4.5.
- [3] : The operation mode, after the transceiver powers on, has to start from sleep mode.
- [4] : If TXD is low level when releasing the thermal shutdown, TXD has to toggle "High" before transmitting TXD. For details, refer to section 5.4.7.

5.2 Master Node

- There is only one node in a system, which functions as a schedule manager and a primary clock master.
- The transceiver works in Master mode when low-level is applied on SELMS. See [Table 5-1](#).
- The baud rate clock is applied on the CLK pin in the Master state. See [Figure 5-2](#).
- The transceiver is usually used as the "Master" or "Slave", except for the "Secondary Clock master function".
- The SELMS input should not be changed in normal mode.
- The SELMS input should not be changed during wakeup pulse transmission in Sleep mode.
- The CLK pin inputs for the baud rate clock in Master state.

Table 5-1. SELMS Pin State for Master

Pin	Input Signal	Master/Slave
SELMS	Low	Master

Figure 5-2. CLK Input -> BUS Signal (Master)

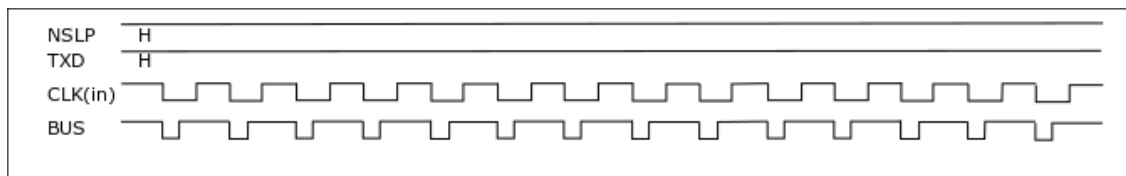

5.2.1 Normal Mode

The Normal mode denotes the state to which communication is possible. The master node transmits the clock to the CXPI BUS, which means that the clock is the master. During the Normal mode, the transmitted signal is encoded and the received signal is decoded. When the transmitting node transmits data to the CXPI BUS, it transmits to the TXD pin after converting the data to a UART format by 1 byte. The data is transmitted to the CXPI BUS as LSB first.

When the receiving node receives data from the CXPI BUS, it receives from the RXD pin in the UART format by 1 byte. The UART format is listed in [Table 5-2](#). Refer to the JASO CXPI (JASO D 015-3:2015) standard for details of the operation.

Table 5-2. UART Format

Start bit	bit 0 (LSB)	bit 1	bit 2	bit 3	bit 4	bit 5	bit 6	bit 7 (MSB)	Stop bit
-----------	-------------	-------	-------	-------	-------	-------	-------	-------------	----------

5.2.2 Sleep Mode

The Sleep mode denotes a power-saving state during which each node stops transmitting and receiving data. All nodes transition to Sleep mode immediately after power-on. The nodes also transition to Sleep mode after the Sleep processing is executed from the Normal mode and transition from Standby mode or Normal mode due to CXPI BUS error.

When each node receives the Wakeup condition during the Sleep mode, it transitions to the Standby mode. The Wakeup condition (for example, detecting that the ignition has been turned on) of each node is different for each application and the external factor that receives the Wakeup pulse from the CXPI BUS. During the Sleep mode, the reception signal is received without decoding. The MCU can detect a wakeup pulse width by monitoring the RXD signal.

The sleep mode is initiated by a falling edge on the NSLP pin while TXD is already set high level. The CXPI BUS transmitter output driver is immediately disabled when the NSLP pin goes low level. The transceiver becomes the normal mode with input high level. When the input level is switched from low to high, the BUS pin and RXD pin output Hi-Z level during the mode transition time (T_{MODE_CHG} in Table 8-7).

Stopping the clock input at high level of CLK is recommended. Then turn the NSLP pin to low level after T_{SLP_WT} as shown in Figure 5-3.

The “Pin State” of Table 5-3 indicates before the falling edge in the NSLP pin.

Table 5-3. Transition from Normal to Sleep mode

Pin	Pin State	Description
TXD	High	No data transmitting
CLK	High	No clock receiving
NSLP	High to Low	-
RXD	High impedance	High level with external pull-up resistor.
BUS	High impedance	High level with external pull-up resistor.
SELMS	Low	-

The “Pin State” of Table 5-4 indicates the state before the rising edge in the NSLP pin.

Table 5-4. Transition from Sleep to Normal mode

Pin	Pin State	Description
TXD	High	No data transmitting
CLK	High	No clock receiving
NSLP	Low to High	-
RXD	High impedance	High level with external pull-up resistor.
BUS	High impedance	High level with external pull-up resistor.
SELMS	Low	-

Figure 5-3. Transition Sequence Between Sleep and Normal Mode

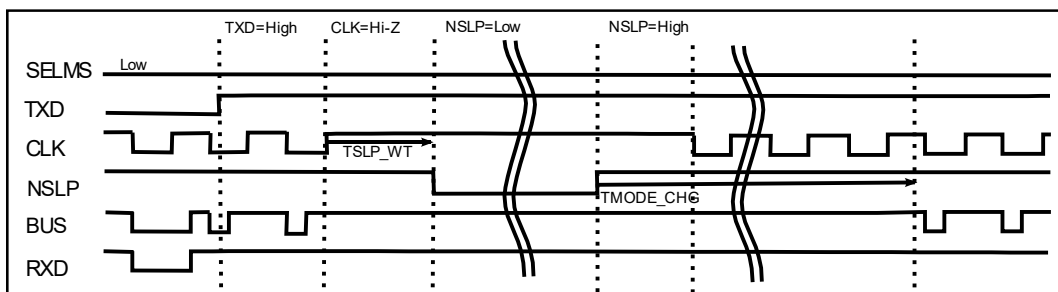

Note:

[1] "Hi-Z" means high-impedance.

5.2.3 Standby Mode

The Standby mode denotes the state of standing by the transition to the Normal mode. The standby mode shall transit only from the sleep mode. The standby mode is not allowed message transition and reception after releasing the Sleep mode. During this mode, the RXD pin and the BUS pin are in a high-impedance state. After T_{MODE_CHG} , the state changes to the Normal mode. Then, the BUS pin activates after a clock input of 33 periods.

5.2.4 Power-on Sequence

The power-on sequence occurs at power-up while setting up Sleep mode. When V_{BAT} is above 5.3 V, the NSLP pin can be set to high level. After the transition to the normal mode, the BUS pin activates after a clock input of 33 periods. See [Figure 5-4](#).

Figure 5-4. Power-on Sequence of Master Node

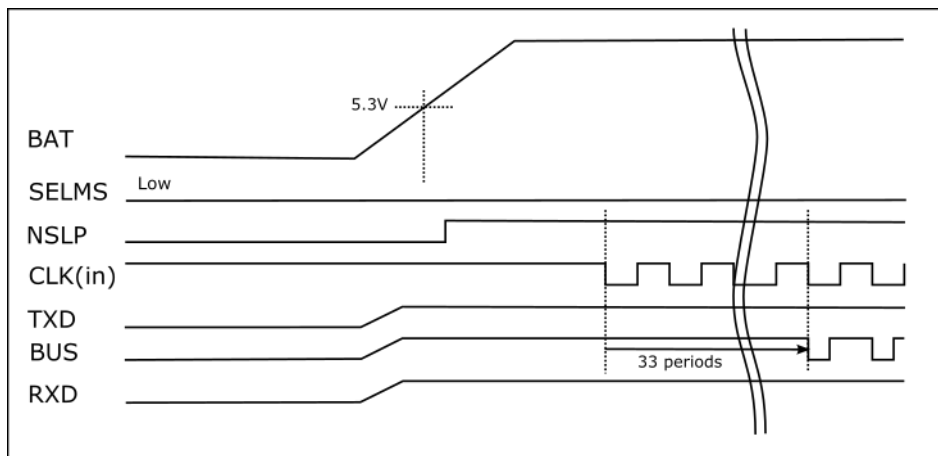

5.3 Slave Node

All the nodes, except the master node, are connected as slave in the system. The transceiver works as Slave when high level is applied on SELMS pin. See [Table 5-5](#). The CLK pin outputs the baud rate clock during the Slave state.

The transceiver is usually used as the "Master" or "Slave", except for the "Secondary Clock master function".

Table 5-5. SELMS Pin State for Slave

Pin	Input Signal	Master/Slave
SELMS	High	Slave

The SELMS input should not be changed during the Normal mode or during wakeup pulse transmission in the Sleep mode. The CLK pin outputs the baud rate clock in Slave node. See [Figure 5-5](#).

Figure 5-5. CLK Pin Clock Output (Slave)

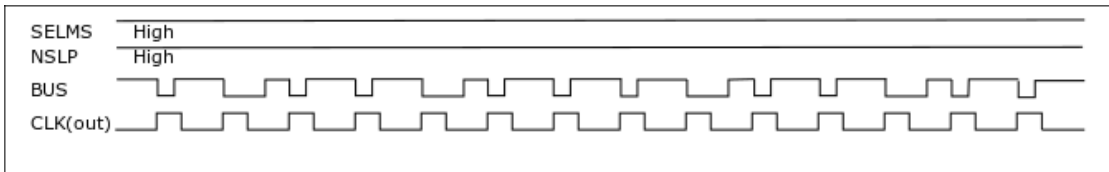

5.3.1 Normal Mode

The Normal mode can perform data transmit and receive. During the Normal mode, the signal that is transmitted is encoded and the signal that is received is decoded. When the transmitting node transmits data to the CXPI BUS, it transmits to the TXD pin after converting the data to a UART format by 1 byte. The data is transmitted to the CXPI BUS by LSB first. When the receiving node receives data from the CXPI BUS, it receives from the RXD pin in the UART format by 1 byte. The UART format is shown in [Table 5-6](#). Refer to the JASO CXPI (JASO D 015-3:2015) standard for details of the operation.

Table 5-6. UART Format

Start bit	bit 0 (LSB)	bit 1	bit 2	bit 3	bit 4	bit 5	bit 6	bit 7(MSB)	Stop bit
-----------	-------------	-------	-------	-------	-------	-------	-------	------------	----------

5.3.2 Sleep Mode

The Sleep mode denotes a state of power saving during which each node stops transmitting and receive data. All nodes transitions to the Sleep mode immediately after power-on. They are also transitioning to the Sleep mode after the sleep processing is executed from the Normal mode and transition from the Standby mode or the Normal mode due to CXPI BUS error.

During the Sleep mode, when each node receives the Wakeup factor, it transitions to the Standby mode. The Wakeup factor is different from each application and is composed of the internal factor (for example, detecting that the ignition has been turned on) and the external factor that receives the Wakeup pulse from the CXPI BUS.

During the Sleep mode, the reception signal is received without decoding. The sleep mode is initiated by a falling edge on the NSLP pin while the TXD pin is already set high level. See Figure 5-6. The CXPI BUS transmits path is immediately disabled when the NSLP pin goes low level.

All wake-up events must be maintained for a specific period (refer to T_{MODE_CHG} in Table 8-7).

Figure 5-6. Transition Sequence Between Sleep and Normal Mode

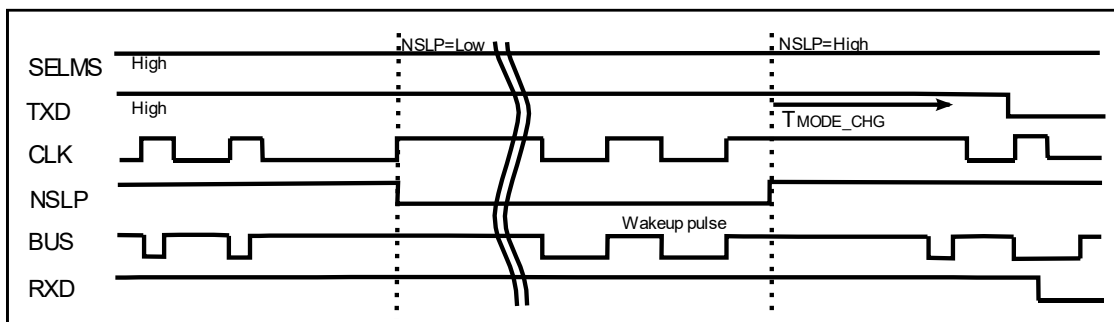

The “Pin State” of Table 5-7 indicates the state before the falling edge of the NSLP pin.

Table 5-7. Transition from Normal to Sleep Mode

Pin	Pin State	Description
TXD	High	No data transmitting
CLK	High impedance	High level with external pull-up resistor.
NSLP	High to Low	-
RXD	High impedance	High level with external pull-up resistor.
BUS	High impedance	High level with external pull-up resistor.
SELMS	High	-

The “Pin State” of Table 5-8 indicates the state before the rising edge of the NSLP pin.

Table 5-8. Transition from Sleep to Normal Mode

Pin	Pin State	Description
TXD	High	No data transmitting
CLK	High impedance	High level with external pull-up resistor.
NSLP	Low to High	-
RXD	High impedance	High level with external pull-up resistor.
BUS	High impedance	High level with external pull-up resistor.
SELMS	High	-

■ Receiver Function in Sleep Mode

During the Sleep mode, the received signal will be output from the CLK pin without decoding a received signal. The RXD pin outputs at a high level. When the Master node wake-up, it transmits clock signal to the CXPI BUS. During a wake-up sequence, the slave transceiver does not decode the received signal. So, if the transceiver outputs this signal to RXD, slave MCUs receive shorter low-level width signals than the UART communication period and it possibly gets errors. This is because the Slave node is received without decoding. To avoid these errors, S6BT112A01 or S6BT112A02 CXPI transceiver IC outputs receive signals on the CLK pin in the Sleep mode.

The MCU can detect a wake-up pulse width by monitoring the CLK signal. (Figure 5-7).

Figure 5-7. CLK Output of Receive Signal, RXD Stays High (for Slave Node)

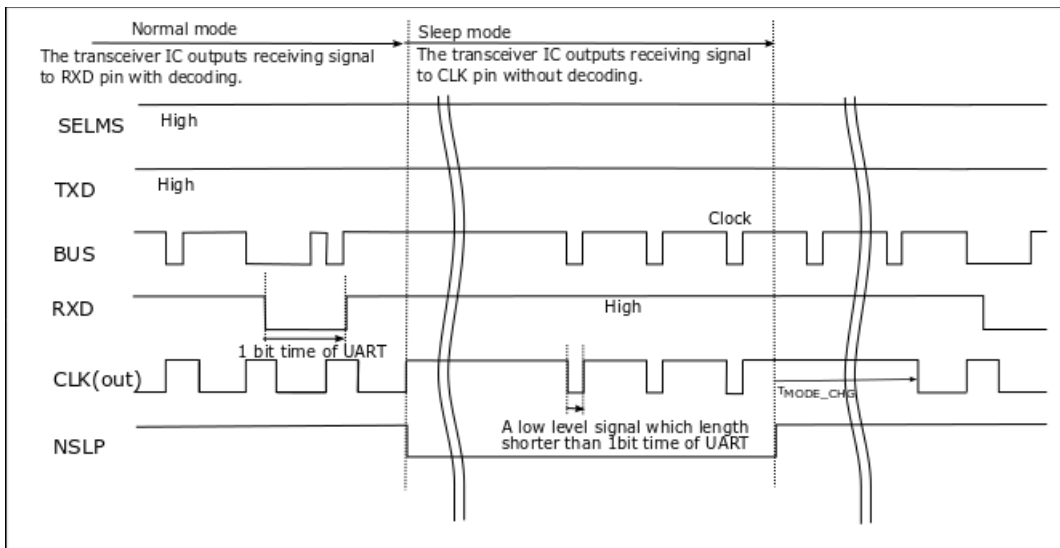

■ Wakeup Function

The WakeupPulseOutput state transmits out the wakeup pulse in the Slave node. When the slave device returns from the Sleep mode, it must transmit a wake-up pulse. As the NSLP pin is in a low level, the TXD pin transmits a low level. The TXD signal is transmitted to the BUS pin without encode. The TXD pin outputs the signal width, which is a value obtained by subtracting the T_{TXD_BT} :

$$\text{Signal width} = \text{TXD signal ("L")} - T_{TXD_BT}("L")$$

See Figure 5-8. Refer to Table 8-7 for $T_{TXD_BT}("L")$.

Figure 5-8. Wake-Up Pulse Transmission

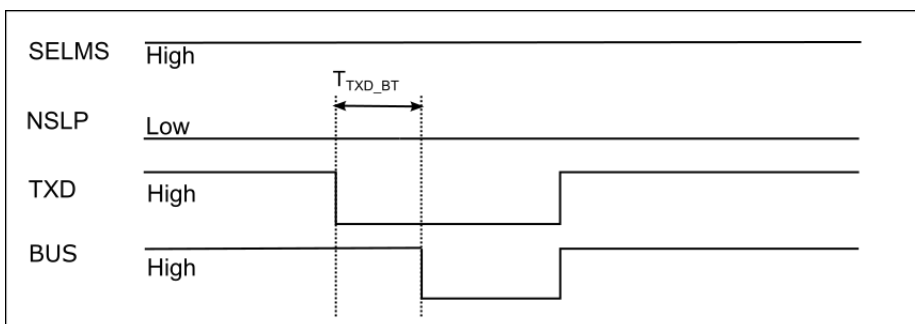

As shown in Table 5-9, in case of 19.2 kbps bitrate, 9 bits (start bit plus 8 bits data) of low level in the TXD signal transmits a 402 μs (min) width wakeup pulse to the BUS. In case of 20 kbps bitrate (50 $\mu\text{s}/\text{Bit}$), to transmit over 400 μs wakeup pulse, over 466 μs TXD low signal is needed, which can be output by a GPIO port with a timer.

Table 5-9. Bitrate of 19.2 kbps (52 $\mu\text{s}/\text{Bit}$)

UART Transmission Data	Number of Bits of L Level	TXD signal ("L")	Wakeup Pulse Width (min)
FCH	3-bit	156 μs	90 μs
F8H	4-bit	208 μs	142 μs
F0H	5-bit	260 μs	194 μs
E0H	6-bit	312 μs	246 μs
C0H	7-bit	364 μs	298 μs
80H	8-bit	416 μs	350 μs
00H	9-bit	468 μs	402 μs

5.3.3 Standby Mode

The Standby mode denotes the state of standing by the transition to the Normal mode. The standby mode shall transit only from the sleep mode. The standby mode is not allowed message transition and reception after releasing the Sleep mode. During this mode, the CLK pin, the RXD pin and the BUS pin are in a high-impedance state. After $T_{\text{MODE_CHG}}$, the state changes to the Normal mode.

5.3.4 Power-on Sequence

This transceiver should be powered up from Sleep mode with the NSLP pin being set to low level. Sleep mode must be released after V_{BAT} is above 5.3 V with the NSLP pin being set to high level. See Figure 5-9.

Figure 5-9. Power-on Sequence of Slave Node

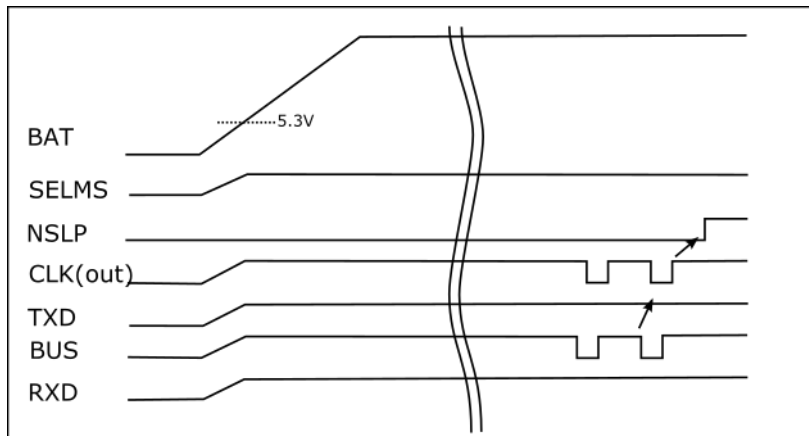

5.4 Common Functions

5.4.1 Overtemperature Protection

The overtemperature protection (OTP) monitors the die temperature. If the junction temperature exceeds the shutdown junction temperature, T_{SD_H} , the thermal protection circuit disables the output driver.

The driver is enabled again when the junction temperature falls below T_{SD_L} and the TXD pin is toggled. (see [Table 5-10](#) and [Figure 5-10](#)).

5.4.2 WP_ThermalShutdown

The WP_ThermalShutdown state detects the "shutdown temperature" during the WakeupPulseOutput mode. See [Table 5-11](#). The overtemperature protection is inactive during the Sleep mode.

Table 5-10. Input Signal Change after Recovery from Thermal Shutdown

Master/Slave	Pin	Toggle of Input Signal
Master	TXD	Required
Slave	TXD	Required

Table 5-11. State Under Thermal Shutdown

Master/Slave	Pin	Description
Master	TXD	Normal function
	NSLP	High: Normal mode / Low: Sleep mode (Thermal protection inactive)
	CLK(input)	Normal function
	RXD	Normal function
	BUS	High impedance
Slave	TXD	Normal function
	NSLP	High: Normal mode / Low: Sleep mode (Thermal protection inactive)
	CLK	Normal function
	RXD	Normal function
	BUS	High impedance

Figure 5-10. Sequence of Thermal Shutdown

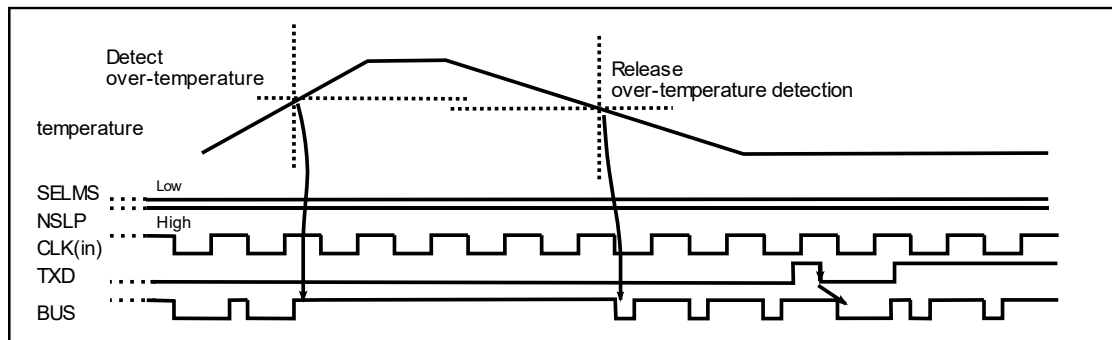

5.4.3 Low-voltage Reset

The low-voltage reset state denotes detecting the low voltage of the BAT pin. See Figure 5-11, Table 5-12, and Table 5-13. This device has an integrated power-on reset and low-voltage detection at the supply BAT.

If the supply voltage, V_{BAT} , is dropping below the power-on reset level (that is, $V_{BAT} < V_{POR_L}$), then the transceiver changes to the LowVoltageReset mode. In the LowVoltageReset mode, the output driver is disabled and communication to the CXPI BUS is not possible.

If the power supply reaches a higher level than the low-voltage reset level, $V_{BAT} > V_{POR_H}$, then transceiver changes to the Standby mode (the NSLP pin is high level) or Sleep mode (the NSLP pin is low level).

After releasing LowVoltageRest mode, transceiver starts the Power-on sequence.

Table 5-12. Input Signal Change after Recovery from Low Voltage Reset

Master/Slave	Pin	Toggle of Input Signal
Master	TXD	Required
Slave	TXD	Required

Table 5-13. State Under Low Voltage Reset

Master/Slave	Pin	Description
Master	SELMS	Reset
	TXD	Reset
	NSLP	Reset
	CLK	Reset(High impedance)
	RXD	High impedance
	BUS	High impedance
Slave	SELMS	Reset
	TXD	Reset
	NSLP	Reset
	CLK	Reset(High impedance)
	RXD	High impedance
	BUS	High impedance

Figure 5-11. Low-Voltage Detection

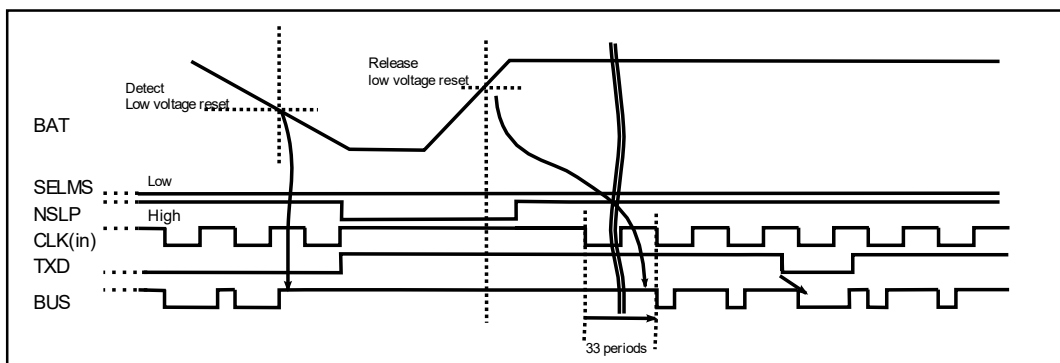

After releasing the low-voltage reset mode, the logical value high is output to the BUS pin after a clock input of 33 periods. The TXD data is valid from the falling edge on the TXD pin.

5.4.4 Overcurrent Protection

The current in the transmitter output driver is limited to protect the transmitter against short-circuit to BAT or GND pins. See [Table 5-14](#).

Table 5-14. State Under Overcurrent Protection

Master/Slave	Pin	Description
Master	TXD	Normal function
	NSLP	Normal function
	CLK	Normal function
	RXD	Normal function
	BUS	Output current limited by IBUS_LIM
Slave	TXD	Normal function
	NSLP	Normal function
	CLK	Normal function
	RXD	Normal function
	BUS	Output current limited by IBUS_LIM

5.4.5 Secondary Clock Master

The node that detects the wakeup event transmits the wakeup pulse on to the CXPI BUS. If the primary clock master cannot transmit the clock to the CXPI BUS due to failure, the wakeup pulse is retransmitted. If the clock is not transmitted to the CXPI BUS, each node detects the CXPI BUS error.

The secondary clock master may transmit the clock to the CXPI BUS instead of the primary clock master if it detects that the clock does not exist, for a certain period after it transitions from the Sleep mode.

■ Operation sequence from master to slave

After setting the TXD input pin to high level and the CLK pin is high-impedance, set the transceiver to sleep mode by setting the NSLP pin to low level. After confirming no data receiving (the RXD pin is high level), set the SELMS pin from low level to high level. [Table 5-15](#) shows the pin states just before the SELMS pin input signal change. See [Figure 5-12](#) for an application example secondary clock master, and see [Figure 5-13](#) for transition sequence from master to slave.

Table 5-15. Pin State Table (from Master to Slave)

Pin	Pin State	Description
TXD	High	No data transmitting
CLK	High impedance	High level with external pull-up resistor.
NSLP	Low	Sleep mode
SELMS	Low to High	-
RXD	High	No data receiving
BUS	High	No wakeup signal receiving preferred

Figure 5-12. Application Example Secondary Clock Master

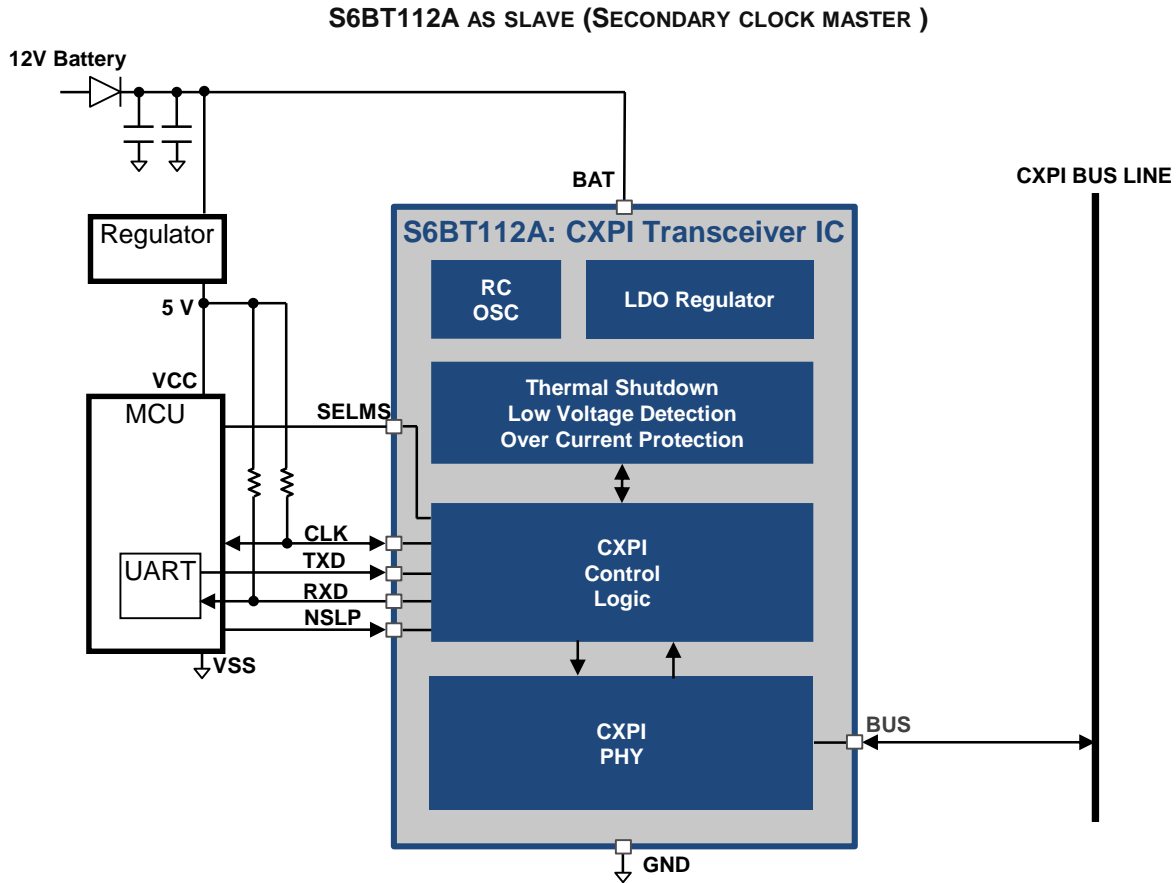
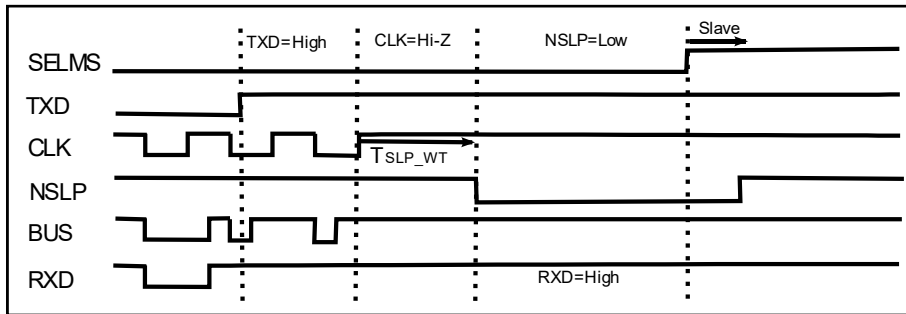

Figure 5-13. Transition Sequence from Master to Slave



■ Operation sequence from slave to master

After setting the TXD pin to high level and the CLK pin is high level, set the transceiver to the Sleep mode by setting NSLP tpin to low level. After confirming no data receiving (the CLK pin is high level), set the SELMS pin from high level to low level.

See [Table 5-16](#) and [Figure 5-14](#).

Table 5-16. Pin State Table (from Slave to Master)

Pin	Pin State	Description
TXD	High	No data transmitting
CLK	High impedance	No wakeup signal receiving
NSLP	Low	Sleep mode
SELMs	High to Low	-
RXD	High	-
BUS	High	No wakeup signal receiving preferred

Note: The pin states just before the SELMS input signal change.

Figure 5-14. Transition Sequence from Slave to Master

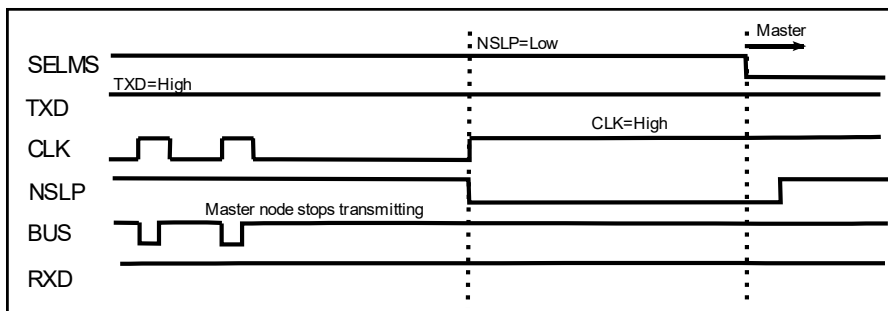

5.4.6 Arbitration

Transceivers arbitrate bit-by-bit. Arbitration in bytes is done in the MCU.

In the Normal mode, each node always compares the received bit from the CXPI BUS with the transmitted bit to the CXPI BUS. When the value of the bit is corresponding, the node may continuously transmit to the CXPI BUS. When the value of the bit is not corresponding, the loss of arbitration is detected, and the transmission of the bit after that shall discontinue. If the transmitting node detects the arbitration loss, it behaves as the receiving node. The data of each bit transmitted on the CXPI BUS performs arbitration from the start by the bit. Moreover, arbitration is targeted at the entire field of the frame. When two or more nodes begin transmitting at the same time, by arbitration only the node that transmits the highest priority frame can complete the transmission.

The MCU compares between the transmitted data (TXD) and received data (RXD). If the data difference is detected, MCU has to stop data transmission until finding IFS.

5.4.7 TXD Toggle

The TXD toggle is an operation in which the TXD pin is first raised to high level and then lowered to low level.

The toggle function of the transceiver initiates a TXD dominant check after the transition to the Normal mode. If the TXD pin is forced permanently low level by a hardware and/or software application failure, transceiver doesn't recognize the TXD pin as low level. See [Figure 5-15](#) and [Figure 5-16](#).

As a result, even if the TXD pin is stuck to low level, the BUS pin does not continue to output a logical value of 0 in normal mode. Therefore, even if the TXD pin is fixed to low level, it does not interfere with the communication of other devices on the BUS.

If the TXD pin is low level, the transmitter output driver remains disabled and is only enabled once the TXD pin goes high level.

A TXD toggle is required in the following cases.

- Data transmission after recovery from low-voltage reset. See [Figure 5-17](#).
- Data transmission after recovery from thermal shutdown.
- First TXD data transmission in the Normal mode.
- First wake-up pulse transmission in sleep mode.

■ Short-circuit from the TXD pin to ground.(failure detect)

In the event of a short-circuit to ground on the TXD pin, the BUS pin output remains High (logical value '1') by this toggle function. In this case, by comparing the sent data to the TXD pin and received data from the RXD pin of the transceiver IC, the MCU can detect the permanent low level on the TXD pin by the data difference. In this case too, the receiver is active.

Figure 5-15. Normal Transmission Sequence of Master

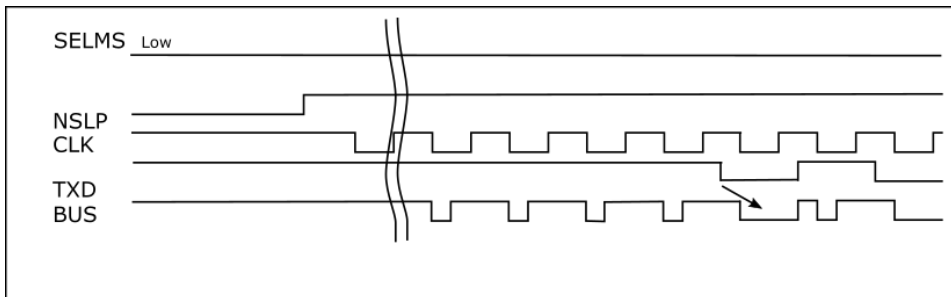

Figure 5-16. TXD Toggle of Master after Transition to Normal mode

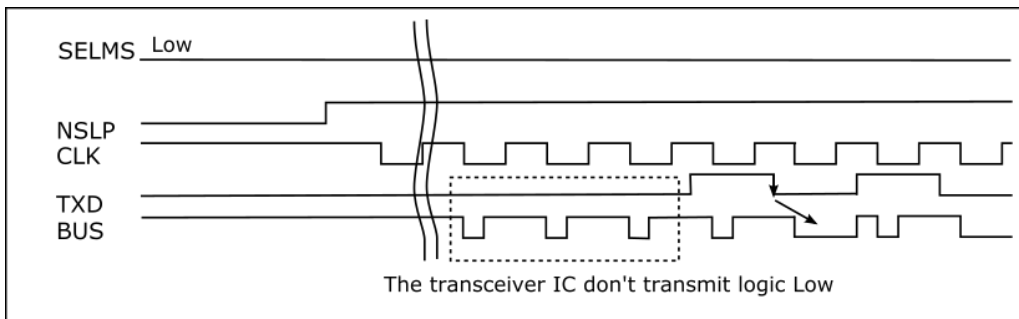
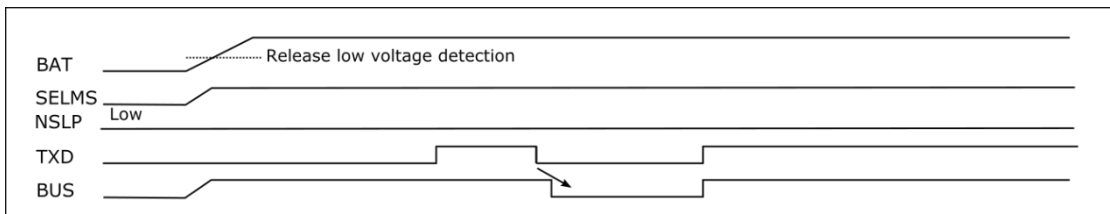

Figure 5-17. Slave TXD Toggle after Recovery from Low voltage State



6. Absolute Maximum Ratings

Semiconductor devices may be permanently damaged by an application of stress (including, without limitation, voltage, current or temperature) in excess of the absolute maximum ratings. Do not exceed any of these ratings.

Parameters	Symbol	Conditions	Rating		Unit
			Min	Max	
Power supply voltage	V _{BAT}	BAT pin	-0.3	40	V
Input voltage	V _{NSLP}	NSLP pin	-0.3	6.9	V
	V _{SELMs}	SELMs pin	-0.3	18	V
	V _{CLK}	CLK pin	-0.3	6.9	V
	V _{TXD}	TXD pin	-0.3	6.9	V
Output voltage	V _{RxD}	RxD pin	-0.3	6.9	V
	V _{CLK}	CLK pin	-0.3	6.9	V
BUS pin voltage	V _{BUS}	BUS pin	-40	40	V
BUS pin ESD (1.5 kΩ, 100 pF)	V _{ESDBUS}	BUS pin	-8	8	kV
BAT pin ESD (1.5 kΩ, 100 pF)	V _{ESDBAT}	BAT pin	-8	8	kV
ESD (1.5 kΩ, 100 pF)	V _{ESD}	NSLP pin SELMs pin CLK pin TXD pin RxD pin	-2	2	kV
Storage temperature	T _{STG}	-	-55	150	°C
Maximum junction temperature	T _{JMAX}	-	-40	150	°C

7. Recommended Operating Conditions

Table 7-1. Recommended Condition

Parameters	Symbol	Conditions	Value			Unit
			Min	Typ	Max	
Power supply voltage	V _{BAT}	BAT pin [1]	5.3	-	18	V
Operating ambient temperature	T _A	-	-40	+25	+125	°C
BUS pin pull-up resistance	R _{MASTER}	BUS pin (Master node : V _{SELMS} =0V)	900	1000	1100	Ω
RXD pin pull-up resistance	R _{RXD}	RXD pin	2.4	10	-	kΩ
CLK pin pull-up resistance	R _{CLK}	CLK pin (V _{SELMS} =5V)	2.4	10	-	kΩ

Note:

[1]: (18 V < V_{BAT} ≤ 27 V) less than 2 minutes.

WARNING:

1. The recommended operating conditions are required to ensure the normal operation of the semiconductor device. All of the device's electrical characteristics are warranted when the device operates under these conditions.
2. Any use of semiconductor devices will be under their recommended operating condition.
3. Operation under any conditions other than these conditions may adversely affect the reliability of the device and could result in device failure.
4. No warranty is made with respect to any use, operating conditions or combinations not represented on this data sheet. If you are considering application under any conditions other than listed herein, please contact sales representatives beforehand.

8. Electrical Characteristics

Table 8-1. DC Characteristics

$V_{BAT} = 5.3\text{ V} \sim 27\text{ V}^{[1]}$, $T_A = -40 \sim 125\text{ }^\circ\text{C}$; All voltages are referenced to Pin 8 (GND); Positive currents flow into the IC; unless otherwise specified.

Parameters	Symbol	Pin Name	Conditions	Min	Typ	Max	Unit
Power supply current	I_{BAT}	BAT	Normal mode $V_{TXD}=5\text{ V}$ $f_{CLK}=20\text{ kHz}$, Duty 50%	-	1.4	2.9	mA
			Normal mode $V_{TXD}=0\text{ V}$ $f_{CLK}=20\text{ kHz}$, Duty 50%	-	2.0	4.0	mA
			Sleep mode $V_{BAT}=12\text{ V}$ $V_{TXD}=5\text{ V}$ $V_{SELMS}=5\text{ V}$ $V_{BUS}=V_{BAT}$ $T_A=25\text{ }^\circ\text{C}$	-	6	10	μA
			Sleep mode $V_{BAT}=12\text{ V}$ $V_{TXD}=5\text{ V}$ $V_{SELMS}=0\text{ V}$ $V_{BUS}=V_{BAT}$ $T_A=25\text{ }^\circ\text{C}$	-	16	-	μA
			Sleep mode $V_{BAT}=12\text{ V}$ $V_{TXD}=5\text{ V}$ $V_{SELMS}=5\text{ V}$ $V_{BUS}=V_{BAT}$	-	-	50	μA
			Sleep mode $V_{BAT}=12\text{ V}$ $V_{TXD}=5\text{ V}$ $V_{SELMS}=0\text{ V}$ $V_{BUS}=V_{BAT}$	-	-	60	μA
BUS pin pull-up resistance	R_{BUSpu}	BUS	-	20	30	47	k Ω
BUS short circuit current	I_{BUS_LIM}	BUS	$V_{BUS}=18\text{ V}$	40	-	200	mA

Parameters	Symbol	Pin Name	Conditions	Min	Typ	Max	Unit
BUS input leak current (HIGH)	$I_{BUS_PAS_rec}$	BUS	$V_{BUS} = 18\text{ V}$ $V_{BAT} = 5.3\text{ V}$ $V_{TXD} = 5\text{ V}$ $T_A = 25\text{ }^\circ\text{C}$	-	-	20	μA
BUS input leak current (LOW)	$I_{BUS_PAS_dom}$	BUS	$V_{BUS} = 0\text{ V}$ $V_{BAT} = 12\text{ V}$ $V_{TXD} = 5\text{ V}$	-1	-	-	mA
loss of ground BUS leak current	$I_{BUS_NO_GND}$	BUS	$V_{BAT} = GND = 18\text{ V}$ $V_{BUS} = 0\text{ V}$	-1	-	1	mA
loss of battery BUS leak current	$I_{BUS_NO_BAT}$	BUS	$V_{BAT} = 0\text{ V}$ $V_{BUS} = 18\text{ V}$ $T_A = 25\text{ }^\circ\text{C}$	-	-	30	μA
BUS drop voltage	V_{BUSDR}	BUS	$V_{BAT} = 13.5\text{ V}$ $I_{BUSsource} = -100\text{ }\mu\text{A}$	2.4	-	5.7	V
BUS low level output voltage	V_{O_dom}	BUS	$V_{TXD} = 0\text{ V}$ $V_{BAT} = 7\text{ V}$ BUS pull-up resistance= 500 Ω	-	-	1.4	V
	V_{O_dom}	BUS	$V_{TXD} = 0\text{ V}$ $V_{BAT} = 18\text{ V}$ BUS pull-up resistance= 500 Ω	-	-	2	V
Receiver low level threshold voltage	V_{BUSdom}	BUS	$V_{BAT} = 12\text{ V}$, $T_A = 25\text{ }^\circ\text{C}$	-	-	0.423 V_{BAT}	V
Receiver high level threshold voltage	V_{BUSrec}	BUS	$V_{BAT} = 12\text{ V}$, $T_A = 25\text{ }^\circ\text{C}$	0.556 V_{BAT}	-	-	V
Receiver hysteresis voltage	V_{HYS}	BUS	$V_{BAT} = 12\text{ V}$, $T_A = 25\text{ }^\circ\text{C}$	-	-	0.133 V_{BAT}	V
Low level power-on reset threshold voltage	V_{POR_L}	BAT	-	3.1	3.8	4.7	V
High level power-on reset threshold voltage	V_{POR_H}	BAT	-	3.3	4.1	4.9	V
power-on reset hysteresis voltage	V_{POR_HYS}	BAT	-	0.2	0.3	0.5	V
Temperature shutdown threshold	T_{SD_H}	-	[2]	156	165	174	$^\circ\text{C}$
Temperature shutdown release threshold	T_{SD_L}	-	[2]	151	159	168	$^\circ\text{C}$

Notes:

[1]: ($18\text{ V} < V_{BAT} \leq 27\text{ V}$) less than 2 minutes.

[2]: Guaranteed by design.

Table 8-2. DC Characteristics CLK Pin

(If SELMS = 5 V, this pin operates as Open Drain Output Pin. If SELMS = 0 V, this pin operates as an input pin).

$V_{BAT} = 5.3\text{ V} \sim 27\text{ V}^{[1]}$, $T_A = -40 \sim 125\text{ }^\circ\text{C}$; all voltages are referenced to Pin 8 (GND). Positive current flow into the IC; unless otherwise specified.

Parameters	Symbol	Pin Name	Conditions	Min	Typ	Max	Unit
High level input voltage	V_{IH_CLK}	CLK	$V_{SELMS} = 0\text{ V}$	2	-	6	V
Low level input voltage	V_{IL_CLK}	CLK	$V_{SELMS} = 0\text{ V}$	-0.3	-	0.8	V
Hysteresis range of input voltage	V_{HYS_CLK}	CLK	$V_{SELMS} = 0\text{ V}$	0.03	-	0.5	V
Low level output voltage	V_{OL_CLK}	CLK	$I_{CLK} = 2.2\text{ mA}$ $V_{SELMS} = 5\text{ V}$	-	-	0.6	V
Low level current	I_{OL_CLK}	CLK	$V_{SELMS} = 5\text{ V}$, $V_{CLK} = 0.4\text{ V}$	1.3	3	-	mA
High level leak current	I_{IH_CLK}	CLK	$V_{SELMS} = 5\text{ V}$ $V_{CLK} = 5\text{ V}$	-3	-	3	μA
Low level leak current	I_{IL_CLK}	CLK	$V_{SELMS} = 5\text{ V}$ $V_{CLK} = 0\text{ V}$	-3	-	3	μA

Note:

[1]: ($18\text{ V} < V_{BAT} \leq 27\text{ V}$) less than 2 minutes.

Table 8-3. DC Characteristics NSLP Pin

$V_{BAT} = 5.3\text{ V} \sim 27\text{ V}^{[1]}$, $T_A = -40 \sim 125\text{ }^\circ\text{C}$; all voltages are referenced to Pin 8 (GND). Positive current flow into the IC; unless otherwise specified.

Parameters	Symbol	Pin Name	Conditions	Min	Typ	Max	Unit
High level input voltage	V_{IH_NSLP}	NSLP	-	2	-	6	V
Low level input voltage	V_{IL_NSLP}	NSLP	-	-0.3	-	0.8	V
Hysteresis range of input voltage	V_{HYS_NSLP}	NSLP	-	0.03	-	0.5	V
Internal pull-down resistance	R_{PD_NSLP}	NSLP	$V_{NSLP} = 5\text{ V}$	100	250	650	k Ω
Low level leak current	I_{IL_NSLP}	NSLP	$V_{NSLP} = 0\text{ V}$	-3	-	3	μA

Note:

[1]: ($18\text{ V} < V_{BAT} \leq 27\text{ V}$) less than 2 minutes.

Table 8-4. TXD Pin

$V_{BAT} = 5.3\text{ V} \sim 27\text{ V}^{[1]}$, $T_A = -40 \sim 125\text{ }^\circ\text{C}$; all voltages are referenced to Pin 8 (GND). Positive current flow into the IC; unless otherwise specified.

Parameters	Symbol	Pin Name	Conditions	Min	Typ	Max	Unit
High level input voltage	V_{IH_TXD}	TXD	-	2	-	6	V
Low level input voltage	V_{IL_TXD}	TXD	-	-0.3	-	0.8	V
Hysteresis range of input voltage	V_{HYS_TXD}	TXD	-	0.03	-	0.5	V
Internal pull-up resistance	R_{PU_TXD}	TXD	$V_{TXD} = 0\text{ V}$	50	125	325	k Ω
High level leak current	I_{IH_TXD}	TXD	$V_{TXD} = 5\text{ V}$	-3	-	3	μA

Note:

[1]: ($18\text{ V} < V_{BAT} \leq 27\text{ V}$) less than 2 minutes.

Table 8-5. SELMS Pin

$V_{BAT} = 5.3\text{ V} \sim 27\text{ V}^{[1]}$, $T_A = -40 \sim 125\text{ }^\circ\text{C}$; all voltages are referenced to Pin 8 (GND). Positive current flow into the IC; unless otherwise specified.

Parameters	Symbol	Pin Name	Conditions	Min	Typ	Max	Unit
High level input voltage	V_{IH_SELMS}	SELMS	-	2	-	6	V
Low level input voltage	V_{IL_SELMS}	SELMS	-	-0.3	-	0.8	V
Hysteresis range of input voltage	V_{HYS_SELMS}	SELMS	-	0.03	-	0.5	V
Internal pull-up resistance	R_{PU_SELMS}	SELMS	$V_{SELMS} = 0\text{ V}$	200	500	1300	k Ω
High level leak current	I_{IH_SELMS}	SELMS	$V_{SELMS} = 5\text{ V}$	-3	-	3	μA

Note:

[1]: ($18\text{ V} < V_{BAT} \leq 27\text{ V}$) less than 2 minutes.

Table 8-6. RXD Pin (Open Drain Output)

$V_{BAT} = 5.3\text{ V} \sim 27\text{ V}^{[1]}$, $T_A = -40 \sim 125\text{ }^\circ\text{C}$; all voltages are referenced to Pin 8 (GND). Positive current flow into the IC; unless otherwise specified.

Parameters	Symbol	Pin Name	Conditions	Min	Typ	Max	Unit
Low level output voltage	V_{OL_RXD}	RXD	$I_{RXD} = 2.2\text{ mA}$	-	-	0.6	V
Low level current	I_{OL_RXD}	RXD	$RXD = 0.4\text{ V}$	1.3	3	-	mA
High level leak current	I_{OLH_RXD}	RXD	$RXD = 5\text{ V}$	-3	-	3	μA
Low level leak current	I_{OLL_RXD}	RXD	$RXD = 0\text{ V}$	-3	-	3	μA

Note:

[1]: ($18\text{ V} < V_{BAT} \leq 27\text{ V}$) less than 2 minutes.

Table 8-7. AC Characteristics

$V_{BAT} = 5.3\text{ V} \sim 27\text{ V}^{[1]}$, $T_A = -40 \sim 125\text{ }^\circ\text{C}$ BUS Load 1 k Ω / 1 nF; unless otherwise specified.

Parameters	Symbol	Pin Name	Conditions	Min	Typ	Max	Unit
Bitrate (see Figure 8-1)	T_{BUAD}	BUS	$V_{TH(BUS)}^{[3]} = 0.5V_{BAT}$	2.4	-	20	kbps
Mode transition time (Sleep to Normal or Normal to Sleep.) (see Figure 8-2)	T_{MODE_CHG}	NSLP	$V_{TH(5\text{ V})}^{[4]} = 50\%$	-	-	1	ms
NSLP wait time (see Figure 8-3)	T_{SLP_WT}	CLK NSLP	$V_{TH(5\text{ V})}^{[4]} = 50\%$	100	-	-	μs
Minimum sleep time (see Figure 8-4)	T_{SLP_MN}	NSLP	-	1	-	-	ms
Driver boot time under sleep mode. ^[2] (see Figure 8-5)	T_{TXD_BT}	TXD	$V_{BUT} = 7\text{V} \sim 27\text{V}$ $V_{NSLP} = 0\text{ V}$ $V_{SELMS} = 5\text{ V}$ $V_{TH(5\text{ V})}^{[4]} = 50\%$ $V_{TH(BUS)}^{[3]} = 0.3V_{BAT}$	-	-	66	μs
CLK transmission delay time (see Figure 8-6)	T_{CLK_PD}	CLK	$V_{NSLP} = 5\text{ V}$ $V_{SELMS} = 0\text{ V}$ CLK=input clock $V_{TXD} = 5\text{ V}$ $V_{TH(5\text{ V})}^{[4]} = 50\%$ $V_{TH(BUS)}^{[3]} = 0.3V_{BAT}$	-	-	0.9	Tbit ^[5]

Parameters	Symbol	Pin Name	Conditions	Min	Typ	Max	Unit
Time of Low level of logic value '1' (see Figure 8-7)	$T_{tx_1_lo_rec}$	BUS	$V_{NSLP} = 5\text{ V}$ $V_{SELMS} = 0\text{ V}$ CLK=input clock $V_{TXD} = 5\text{ V}$ $V_{TH}(BUS)^{[3]} = 0.7V_{BAT}$	-	-	0.39Tbit +0.6T	-
Time of Low level of logic value '1' (see Figure 8-7)	$T_{tx_1_lo_dom}$	BUS	$V_{NSLP} = 5\text{ V}$ $V_{SELMS} = 0\text{ V}$ CLK=input clock $V_{TXD} = 5\text{ V}$ $V_{TH}(BUS)^{[3]} = 0.3 V_{BAT}$	0.11	-	-	Tbit
Time of Low level of logic value '0' (see Figure 8-7)	$T_{tx_0_lo_rec}$	BUS	$V_{NSLP} = 5\text{ V}$ $V_{TXD} = 0\text{ V}$ $V_{TH}(BUS)^{[3]} = 0.7 V_{BAT}$	$T_{tx_1_lo_rec}$ +0.06Tbit	-	-	-
Time of Low level of logic value '0' (see Figure 8-7)	$T_{tx_0_lo_dom}$	BUS	$V_{NSLP} = 5\text{ V}$ $V_{TXD} = 0\text{ V}$ $V_{TH}(BUS)^{[3]} = 0.3 V_{BAT}$	$T_{tx_1_lo_dom}$ +0.06Tbit	-	-	-
High level time at receiving node. (see Figure 8-7)	$T_{tx_0_hi}$	BUS	$V_{NSLP} = 5\text{ V}$ $V_{TXD} = 0\text{ V}$ $V_{TH}(BUS)^{[3]} = 0.556 V_{BAT}$	0.06	-	-	Tbit
Receiver delay time (see Figure 8-8)	T_{RXD_PD}	RXD	$V_{NSLP} = 5\text{ V}$ $V_{TH}(BUS)^{[3]} = V_{BUSdom}$	-	-	1.0	Tbit
Delay time of transmission if logic value '0'. (see Figure 8-9)	T_{TXD_PD}	TXD	$V_{NSLP} = 5\text{ V}$ $V_{TH}(BUS)^{[3]} = 0.3 V_{BAT}$	-	-	2.0	Tbit
Input clock duty	T_{CLK_DY}	CLK	$V_{SELMS} = 0\text{ V}$ $V_{TH}(5\text{ V})^{[4]} = 50\%$	30	-	70	%
Output clock duty ^[6]	T_{OCLK_DY}	CLK	$V_{SELMS} = 5\text{ V}$ $V_{TH}(5\text{ V})^{[4]} = 50\%$	14	-	50	%
Wakeup pulse filter constant(Master) ^[7] (see Figure 8-10)	$T_{rx_wakeup_master}$	BUS	$V_{NSLP} = 0\text{ V}$ $V_{SELMS} = 0\text{ V}$ $V_{TH}(BUS)^{[3]} = 42.3\%$	30	-	150	μs

Parameters	Symbol	Pin Name	Conditions	Min	Typ	Max	Unit
Wakeup pulse filter constant(Slave) ^[7] (see Figure 8-10)	$T_{rx_wakeup_slave}$	BUS	$V_{NSLP} = 0\text{ V}$ $V_{SELMS} = 5\text{ V}$ $V_{TH}(BUS)^{[3]} = 42.3\%$	0.5	-	5	μs
Time of bus slope from minimum (see Figure 8-7)	$T_{tx_1_dom_m}$	BUS	$V_{NSLP} = 5\text{ V}$ $V_{SELMS} = 0\text{ V}$ $V_{BAT} = 7\text{ V}$ $V_{TH}(BUS)^{[3]} = 0.3 V_{BAT}$	-	-	0.16	Tbit
Recessive level of logical value '0'.	V_{rec_0}	BUS	$V_{NSLP} = 5\text{ V}$	0.93	-	-	V_{rec_1}

Notes:

- [1]: ($18\text{ V} < V_{BAT} \leq 27\text{ V}$) less than 2 minutes.
RXD pin load: 20 pF.
- [2]: CXPI BUS load (Figure 8-11) : 10 nF/500 Ω .
- [3]: $V_{TH}(BUS)$: threshold of BUS pin.
- [4]: $V_{TH}(5\text{ V})$: threshold of NSLP,CLK,TXD,SELMS,RXD pins.
- [5]: Tbit stands for 1bit time.(Figure 8-1)
- [6]: logic '0/1' threshold clock.
- [7]: Pulse widths greater than Max are output to RXD, pulse widths less than Min are excluded.

Figure 8-1. Definition of Tbit

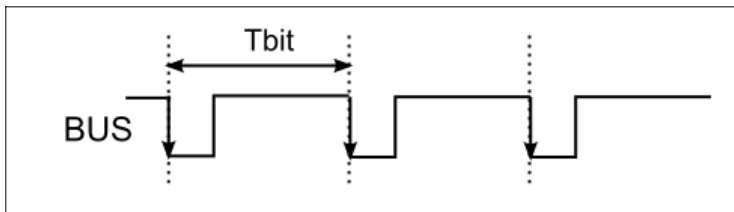

Figure 8-2. Mode Transition Time

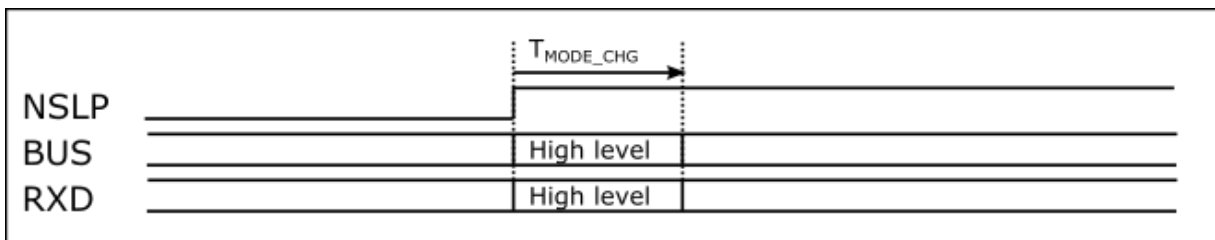

Figure 8-3. NSLP Wait Time

Figure 8-4. Minimum Sleep Time

Figure 8-5. Driver Boot Time Under Sleep Mode

Figure 8-6. CLK Transmission Delay Time

Figure 8-7. Logic Low and High CXPI BUS Waveform

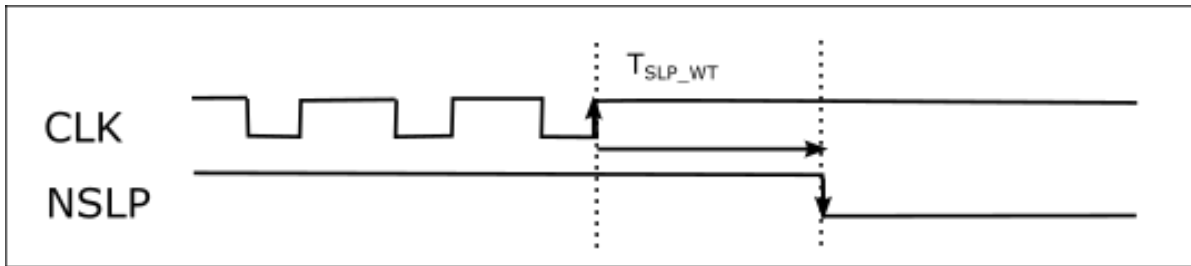
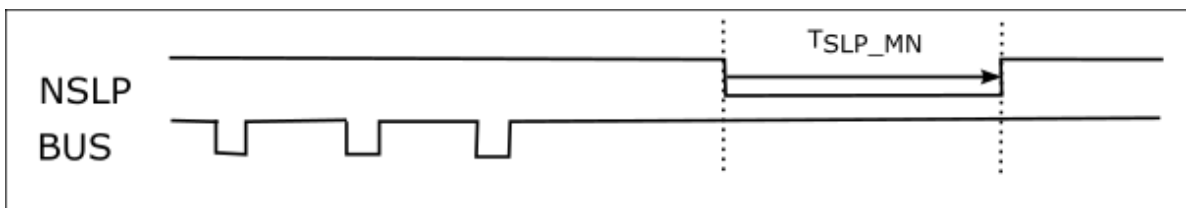
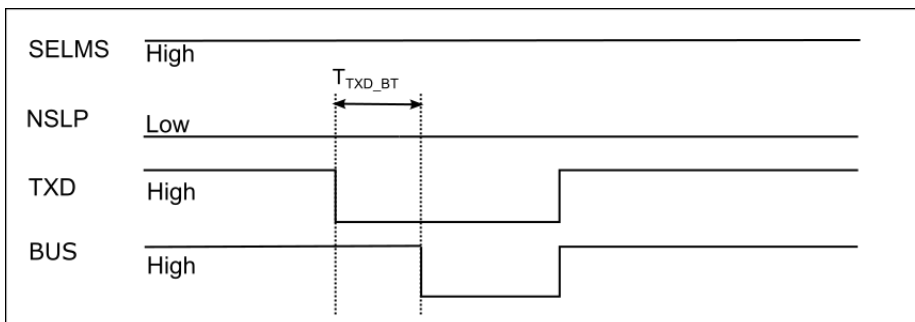
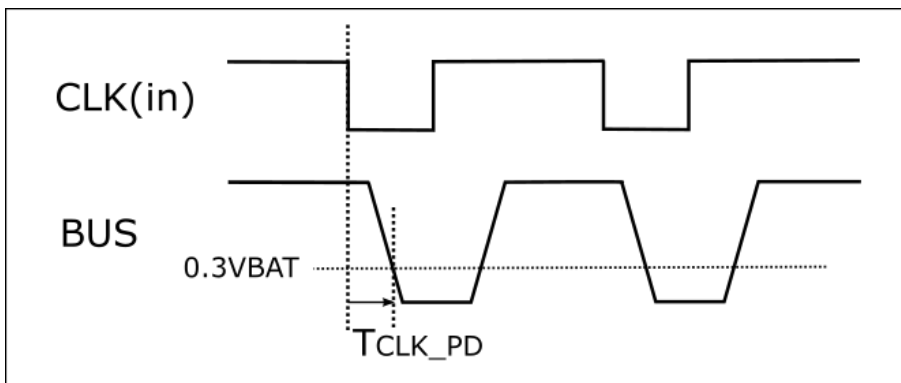
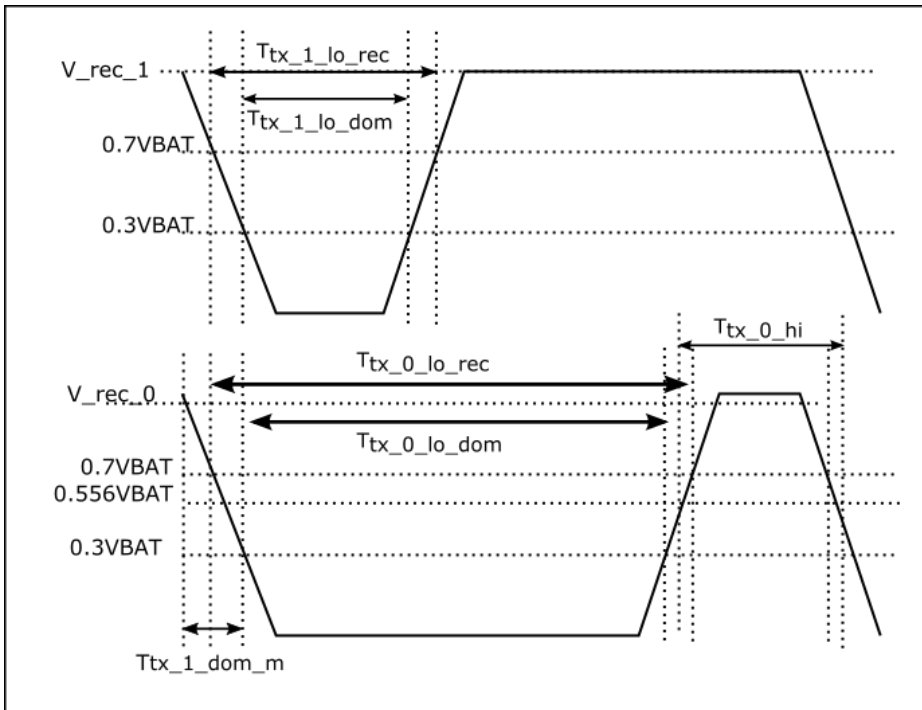

Figure 8-8. Receiver Delay Time

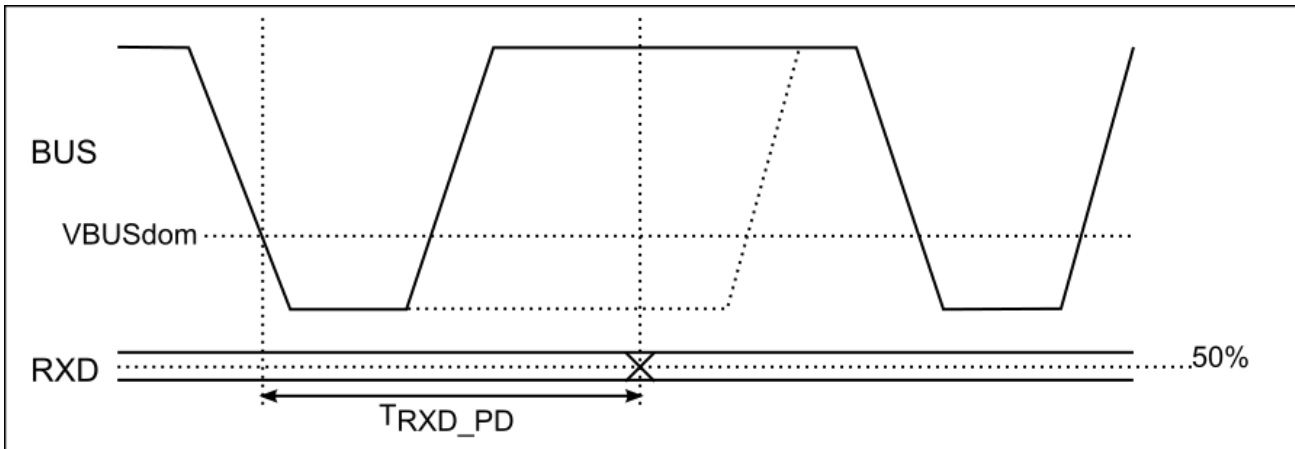

Figure 8-9. Logic Low Transmission Delay Time

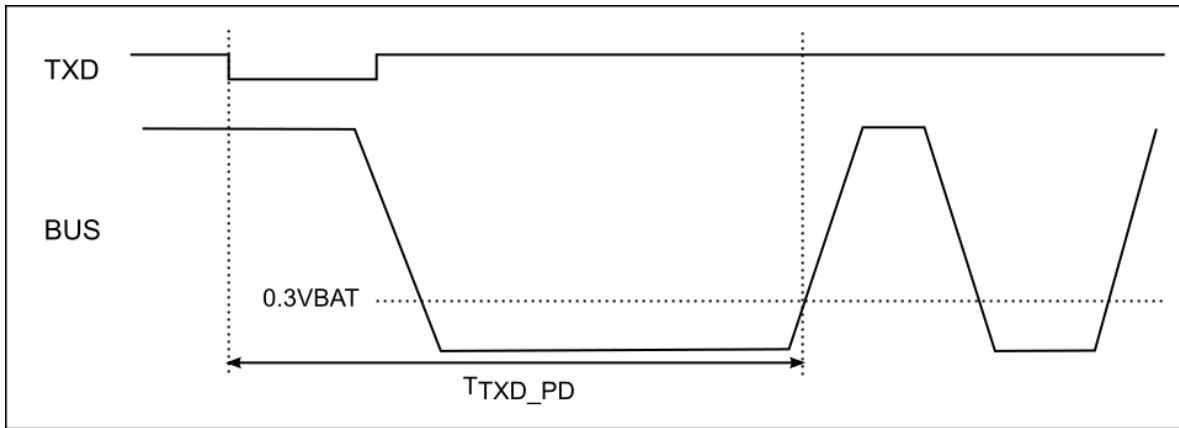

Figure 8-10. Wakeup Pulse Waveform

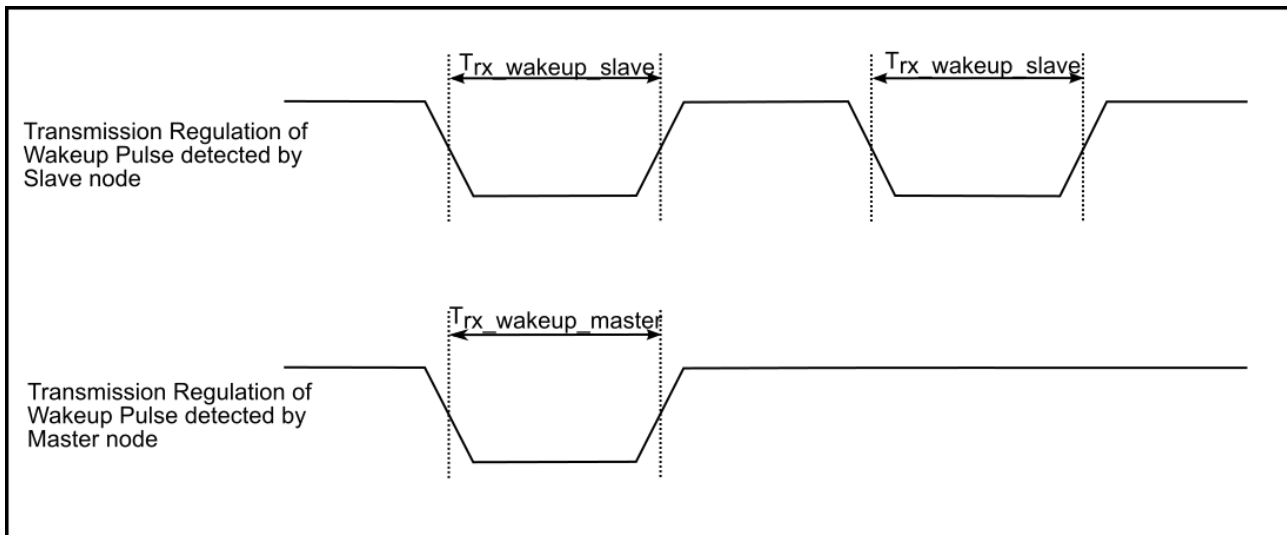
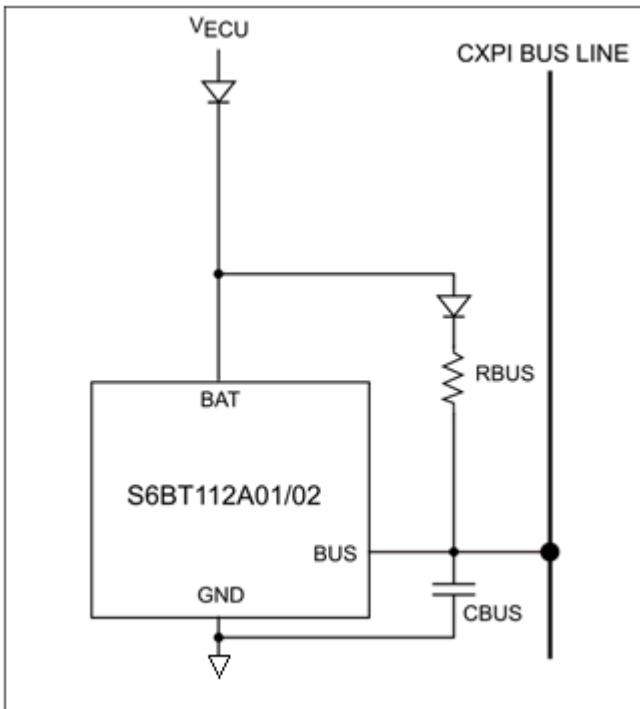

Figure 8-11. CXPI BUS Load Connection



9. Ordering Information

Part Number	Package
S6BT112A01SSBB002	8-pin 150-mil SOIC Tape and Reel (SOA008)
S6BT112A02SSBB002	8-pin 150-mil SOIC Tape and Reel (SOA008)





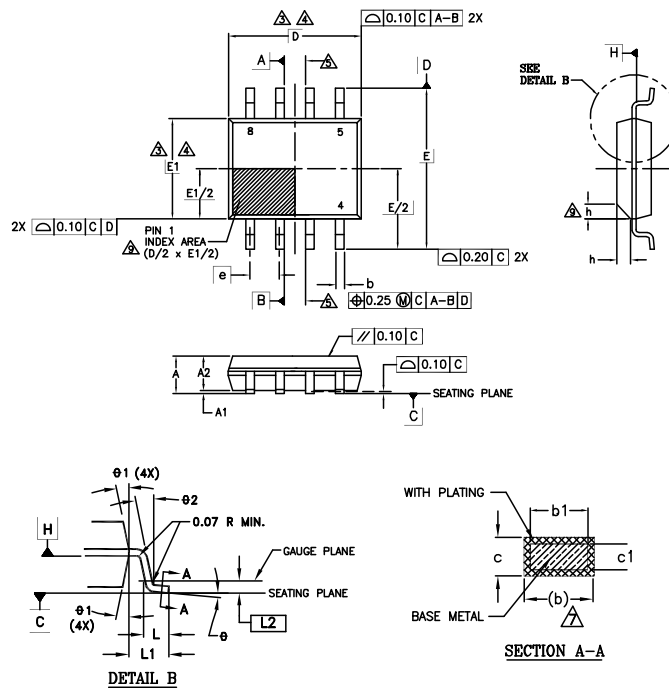

10. Package Dimensions

Package Type	Package Code
SOP 8	SOA 008



SYMBOL	DIMENSIONS		
	MIN.	NOM.	MAX.
A	-	-	1.75
A1	0.10	-	0.25
A2	1.32	-	-
b	0.31	-	0.51
b1	0.28	-	0.48
c	0.17	-	0.25
c1	0.17	-	0.23
D	4.90 BSC		
E	6.00 BSC		
E1	3.90 BSC		
e	1.27 BSC		
L	0.40	-	0.89
L1	1.04 REF		
L2	0.25 BSC		
N	8		
h	0.25	-	0.50
θ	0°	-	8°
θ 1	5°	-	15°
θ 2	0° REF		

NOTES:

- ALL DIMENSIONS ARE IN MILLIMETERS.
- DIMENSIONING AND TOLERANCING PER ASME Y14.5M - 1994.
-  DIMENSION D DOES NOT INCLUDE MOLD FLASH, PROTRUSIONS OR GATE BURRS. MOLD FLASH, PROTRUSIONS OR GATE BURRS SHALL NOT EXCEED 0.15 mm PER END. DIMENSION E1 DOES NOT INCLUDE INTERLEAD FLASH OR PROTRUSION. INTERLEAD FLASH OR PROTRUSION SHALL NOT EXCEED 0.25 mm PER SIDE. D AND E1 DIMENSIONS ARE DETERMINED AT DATUM H.
-  THE PACKAGE TOP MAY BE SMALLER THAN THE PACKAGE BOTTOM. DIMENSIONS D AND E1 ARE DETERMINED AT THE OUTMOST EXTREMES OF THE PLASTIC BODY EXCLUSIVE OF MOLD FLASH, TIE BAR BURRS, GATE BURRS AND INTERLEAD FLASH, BUT INCLUSIVE OF ANY MISMATCH BETWEEN THE TOP AND BOTTOM OF THE PLASTIC BODY.
-  DATUMS A AND B TO BE DETERMINED AT DATUM H.
- "N" IS THE MAXIMUM NUMBER OF TERMINAL POSITIONS FOR THE SPECIFIED PACKAGE LENGTH.
-  THE DIMENSIONS APPLY TO THE FLAT SECTION OF THE LEAD BETWEEN 0.10 TO 0.25 mm FROM THE LEAD TIP.
-  DIMENSION "b" DOES NOT INCLUDE DAMBAR PROTRUSION. ALLOWABLE DAMBAR PROTRUSION SHALL BE 0.10 mm TOTAL IN EXCESS OF THE "b" DIMENSION AT MAXIMUM MATERIAL CONDITION. THE DAMBAR CANNOT BE LOCATED ON THE LOWER RADIUS OF THE LEAD FOOT.
-  THIS CHAMFER FEATURE IS OPTIONAL. IF IT IS NOT PRESENT, THEN A PIN 1 IDENTIFIER MUST BE LOCATED WITHIN THE INDEX AREA INDICATED.
- LEAD COPLANARITY SHALL BE WITHIN 0.10 mm AS MEASURED FROM THE SEATING PLANE.

002-18754 **

Document History

Document Title: S6BT112A01/S6BT112A02 ASSP CXPI Transceiver IC for Automotive Network			
Document Number: 002-10203			
Revision	ECN	Submission Date	Description of Change
**	5046456	12/11/2015	Initial release New Spec.
*A	5208207	04/06/2016	Revised the sentence style of the cover page Changed all section 5 for easy to understand. Changed figure of application. Changed Figure 4-1 and Figure 5-1. Removed "Driver recovery time when over-temperature detection is released."
*B	5528948	11/24/2016	Changed figure of application. Changed Figure 4-1 Block Diagram Changed Figure 5-12 Application example Secondary clock master Added the conditions of $V_{BUSdom}/V_{BUSrec}/V_{HYS}/T_{TX_1_dom_m}$. Removed the parameter of Receiver center level voltage (V_{BUS_CNT}). Changed Figure 8-11 CXPI BUS Load Connection Changed Ordering Information. Changed Package Dimensions.
*C	5547736	12/09/2016	Updated Introduction. Updated Note [3] (Page 8). Updated 5.2 Master Node. Updated 5.2.2 Sleep Mode.
*D	5757034	06/20/2017	Changed figure of 1. Applications Changed Figure 5-12 Application example Secondary Clock Master
*E	6397891	12/04/2018	Changed SOA 008 figure in Package Demensions
*F	6748976	12/23/2019	Added recommendation when stopping clock (Page 9). Corrected Figure 5-2, 5-3, 5-5, 5-6, 5-7, 5-10, 5-11, 5-13, 5-14 Changed Table 5-5 to Table 5-9, 20 kbps to 19.2 kbps. Added explanation (Page 10, 13). Added max. value for IBAT at Sleep mode, SELMS=5V, and TA=25 °C (Page 23). Changed max. value of T_{TXD_BT} to 66 (Page 27). Changed max. value of $T_{TX_1_lo_rec}$ to 0.39Tbit+0.6τ (Page 28). Changed max. value of T_{RXD_PD} to 1.0 (Page 28). Changed max. value of T_{TXD_PD} to 2.0 (Page 28).

Document Title: S6BT112A01/S6BT112A02 ASSP CXPI Transceiver IC for Automotive Network
Document Number: 002-10203

Revision	ECN	Submission Date	Description of Change
*G	6906561	06/28/2020	Updated Introduction. Updated Features. Added title of Figure 1-1 and Figure 1-2. Changed NSLP pin description of Table 3-1. Updated block diagram of figure 4-1. Updated State Transition Diagram of Figure 5-1 and Notes. Updated 5.2 Master Node. Updated 5.3 Slave Node. Updated 5.4 Common functions. Updated style of 7 Recommended Operating Conditions. Updated style of 8 Electrical Characteristics. Added conditons of $I_{OL_CLK} ; V_{CLK} = 0.4 V$. Added conditons of $I_{ILH_CLK} ; V_{CLK} = 5 V$. Added conditons of $I_{ILL_CLK} ; V_{CLK} = 0 V$.

Sales, Solutions, and Legal Information

Worldwide Sales and Design Support

Cypress maintains a worldwide network of offices, solution centers, manufacturer's representatives, and distributors. To find the office closest to you, visit us at [Cypress Locations](#).

Products

Arm® Cortex® Microcontrollers	cypress.com/arm
Automotive	cypress.com/automotive
Clocks & Buffers	cypress.com/clocks
Interface	cypress.com/interface
Internet of Things	cypress.com/iot
Memory	cypress.com/memory
Microcontrollers	cypress.com/mcu
PSoC	cypress.com/psoc
Power Management ICs	cypress.com/pmic
Touch Sensing	cypress.com/touch
USB Controllers	cypress.com/usb
Wireless Connectivity	cypress.com/wireless

PSoC® Solutions

[PSoC 1](#) | [PSoC 3](#) | [PSoC 4](#) | [PSoC 5LP](#) | [PSoC 6 MCU](#)

Cypress Developer Community

[Community](#) | [Code Examples](#) | [Projects](#) | [Videos](#) | [Blogs](#) | [Training](#) | [Components](#)

Technical Support

cypress.com/support

All other trademarks or registered trademarks referenced herein are the property of their respective owners.

© Cypress Semiconductor Corporation, 2015-2020. This document is the property of Cypress Semiconductor Corporation and its subsidiaries ("Cypress"). This document, including any software or firmware included or referenced in this document ("Software"), is owned by Cypress under the intellectual property laws and treaties of the United States and other countries worldwide. Cypress reserves all rights under such laws and treaties and does not, except as specifically stated in this paragraph, grant any license under its patents, copyrights, trademarks, or other intellectual property rights. If the Software is not accompanied by a license agreement and you do not otherwise have a written agreement with Cypress governing the use of the Software, then Cypress hereby grants you a personal, non-exclusive, nontransferable license (without the right to sublicense) (1) under its copyright rights in the Software (a) for Software provided in source code form, to modify and reproduce the Software solely for use with Cypress hardware products, only internally within your organization, and (b) to distribute the Software in binary code form externally to end users (either directly or indirectly through resellers and distributors), solely for use on Cypress hardware product units, and (2) under those claims of Cypress's patents that are infringed by the Software (as provided by Cypress, unmodified) to make, use, distribute, and import the Software solely for use with Cypress hardware products. Any other use, reproduction, modification, translation, or compilation of the Software is prohibited.

TO THE EXTENT PERMITTED BY APPLICABLE LAW, CYPRESS MAKES NO WARRANTY OF ANY KIND, EXPRESS OR IMPLIED, WITH REGARD TO THIS DOCUMENT OR ANY SOFTWARE OR ACCOMPANYING HARDWARE, INCLUDING, BUT NOT LIMITED TO, THE IMPLIED WARRANTIES OF MERCHANTABILITY AND FITNESS FOR A PARTICULAR PURPOSE. No computing device can be absolutely secure. Therefore, despite security measures implemented in Cypress hardware or software products, Cypress shall have no liability arising out of any security breach, such as unauthorized access to or use of a Cypress product. CYPRESS DOES NOT REPRESENT, WARRANT, OR GUARANTEE THAT CYPRESS PRODUCTS, OR SYSTEMS CREATED USING CYPRESS PRODUCTS, WILL BE FREE FROM CORRUPTION, ATTACK, VIRUSES, INTERFERENCE, HACKING, DATA LOSS OR THEFT, OR OTHER SECURITY INTRUSION (collectively, "Security Breach"). Cypress disclaims any liability relating to any Security Breach, and you shall and hereby do release Cypress from any claim, damage, or other liability arising from any Security Breach. In addition, the products described in these materials may contain design defects or errors known as errata which may cause the product to deviate from published specifications. To the extent permitted by applicable law, Cypress reserves the right to make changes to this document without further notice. Cypress does not assume any liability arising out of the application or use of any product or circuit described in this document. Any information provided in this document, including any sample design information or programming code, is provided only for reference purposes. It is the responsibility of the user of this document to properly design, program, and test the functionality and safety of any application made of this information and any resulting product. "High-Risk Device" means any device or system whose failure could cause personal injury, death, or property damage. Examples of High-Risk Devices are weapons, nuclear installations, surgical implants, and other medical devices. "Critical Component" means any component of a High-Risk Device whose failure to perform can be reasonably expected to cause, directly or indirectly, the failure of the High-Risk Device, or to affect its safety or effectiveness. Cypress is not liable, in whole or in part, and you shall and hereby do release Cypress from any claim, damage, or other liability arising from any use of a Cypress product as a Critical Component in a High-Risk Device. You shall indemnify and hold Cypress, its directors, officers, employees, agents, affiliates, distributors, and assigns harmless from and against all claims, costs, damages, and expenses, arising out of any claim, including claims for product liability, personal injury or death, or property damage arising from any use of a Cypress product as a Critical Component in a High-Risk Device. Cypress products are not intended or authorized for use as a Critical Component in any High-Risk Device except to the limited extent that (i) Cypress's published data sheet for the product explicitly states Cypress has qualified the product for use in a specific High-Risk Device, or (ii) Cypress has given you advance written authorization to use the product as a Critical Component in the specific High-Risk Device and you have signed a separate indemnification agreement.

Cypress, the Cypress logo, Spansion, the Spansion logo, and combinations thereof, WICED, PSoC, CapSense, EZ-USB, F-RAM, and Traveo are trademarks or registered trademarks of Cypress in the United States and other countries. For a more complete list of Cypress trademarks, visit cypress.com. Other names and brands may be claimed as property of their respective owners.

X-ON Electronics

Largest Supplier of Electrical and Electronic Components

Click to view similar products for [Interface - Specialised category](#):

Click to view products by [Cypress manufacturer](#):

Other Similar products are found below :

[CY7C910-51LMB](#) [MEC1632-AUE](#) [RKSAS4](#) [HMC677G32](#) [LPC47N207-JV](#) [FTP-637DSL633R](#) [SM712GX04LF04-BA](#) [MCW1001A-I/SS](#)
[HOA6241-001](#) [SC74HC4066ADTR2G](#) [NCN5120MNTWG](#) [NCN5150DR2G](#) [NCN8025MTTBG](#) [C100N50Z4A](#) [DG407AK/883B](#) [SRT2-ATT01](#) [TDA8035HN/C1/S1J](#) [LTC1694CS5#TRMPBF](#) [DS90UB947TRGCRQ1](#) [SP510ECF-L](#) [NCS2300MUTAG](#) [ADG1404YCPZ-REEL](#)
[HMC677LP5E](#) [HMC677LP5ETR](#) [LTC1756EGN#PBF](#) [LTC1955EUH#PBF](#) [LT3669EUFD-2#PBF](#) [LTC6820HMS#3ZZTRPBF](#)
[MXL1543BCAI](#) [MAX3170CAI+](#) [XL1192D](#) [CP82C59AZ](#) [KTU1109EFAA-TR](#) [CH368L](#) [CH7307C-DEF](#) [LTC1694-1IS5#TRMPBF](#)
[LTC1694CS5#TRPBF](#) [LTC1694IS5#TRM](#) [LTS 25-NP](#) [73S8024RN-20IMF](#) [73S8024RN-IL/F](#) [DS2413P+](#) [DS2413P+T&R](#) [DS28E17Q+](#)
[DS8113-RNG+](#) [MAX13036ATI+](#) [MAX13174ECAG+](#) [MAX216CWN+](#) [MAX3172CAI+](#) [AS8222-HSSM](#)