

1A Adjustable/Fixed Low Dropout Linear Regulator

General Description

The IMP1117-ADJ and IMP1117-1.2,-1.5,-1.8,-2.5,-2.85,-3.3 and-5 are low dropout three-terminal regulators with 1A output current capability. These devices have been optimized for low voltage where transient response and minimum input voltage are critical. The 2.85V version is designed specifically to be used in Active Terminators for SCSI bus.

On-chip thermal limiting provides protection against any combination of overload and ambient temperatures that would create excessive junction temperatures.

Unlike PNP type regulators where up to 10% of the output current is wasted as quiescent current, the quiescent current of the IMP1117 flows into the load, increasing efficiency.

The IMP1117 series regulators are available in the industry-standard SOT-223 and TO-252 power packages.

Key Features

- Low dropout voltage
- Load regulation: 0.2% typical
- Optimized for Low Voltage
- On-chip thermal limiting
- Standard SOT-223 and TO-252 packages
- Three-terminal adjustable or fixed low dropout 1.2V,1.5V,1.8V, 2.5V, 2.85V, 3.3V, 5V. Regulators

Applications

- Active SCSI terminators
- High efficiency linear regulators
- Post regulators for switching supplies
- Battery chargers
- 12V to 5V linear regulators
- Motherboard clock supplies

Typical Application

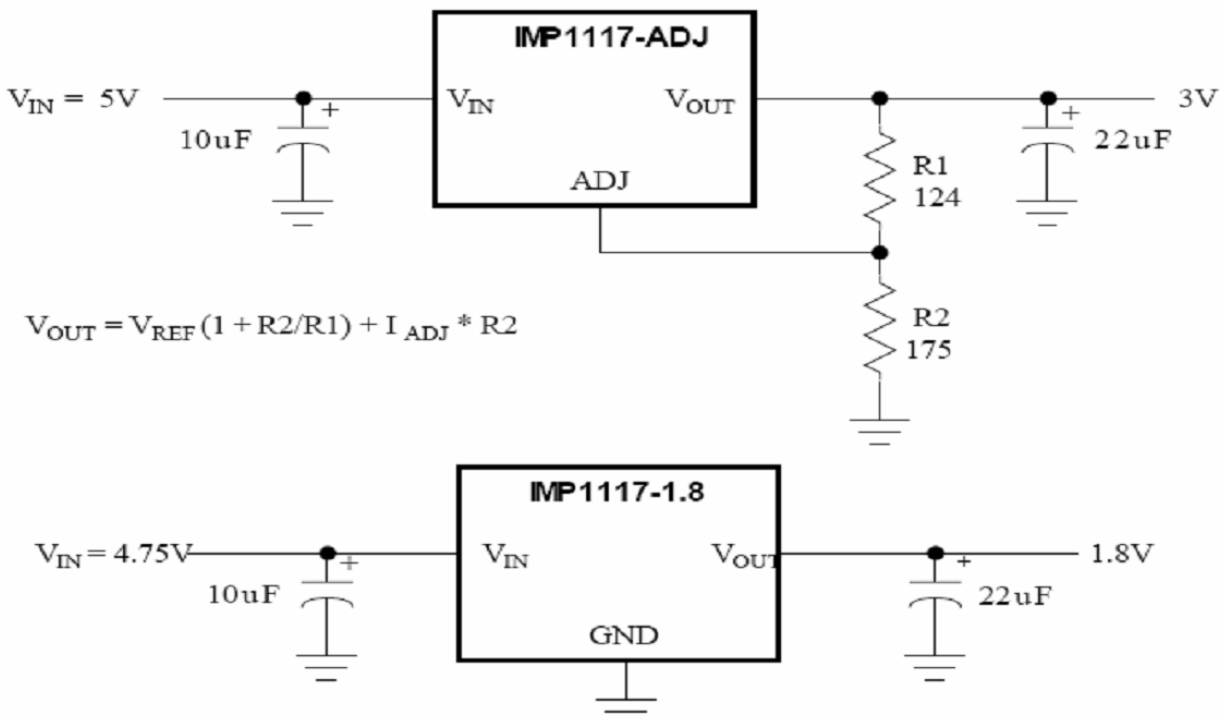

Figure 1. Typical Applications of IMP1117

Notice: The distance between Vout pin and Capacitor should not exceed 4cm for excellent performance

1A Adjustable/Fixed Low Dropout Linear Regulator

Pin Assignments

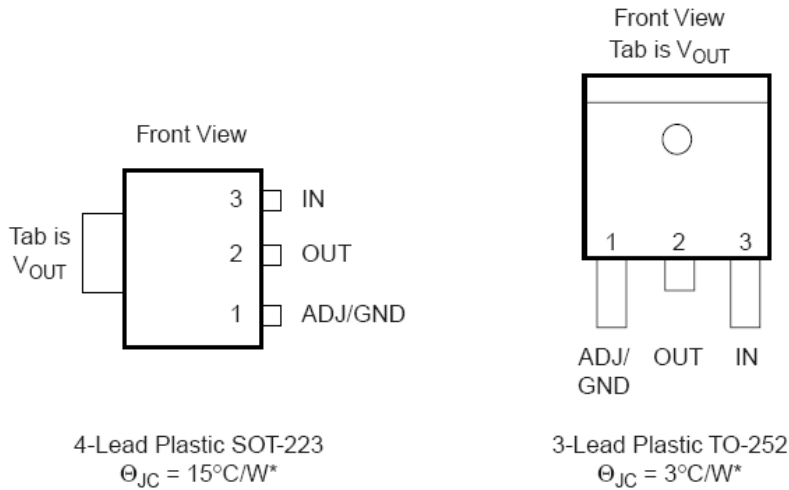

Figure 2. Pin Assignments of IMP1117

*With package soldered to 0.5 square inch copper area over backside ground plane or internal power plane, θ_{JA} can vary from 30°C/W to more than 50°C/W . Other mounting techniques may provide better thermal resistance than 30°C/W .

Absolute Maximum Ratings

Parameter	Min.	Max.	Unit
V_{IN}		18	V
$(V_{IN} - V_{OUT}) * I_{OUT}$		See Figure 3	
Operating Junction Temperature Range	0	125	$^{\circ}\text{C}$
Storage Temperature Range	-65	150	$^{\circ}\text{C}$
Lead Temperature (Soldering, 10 sec.)		300	$^{\circ}\text{C}$

1A Adjustable/Fixed Low Dropout Linear Regulator

Block Diagram

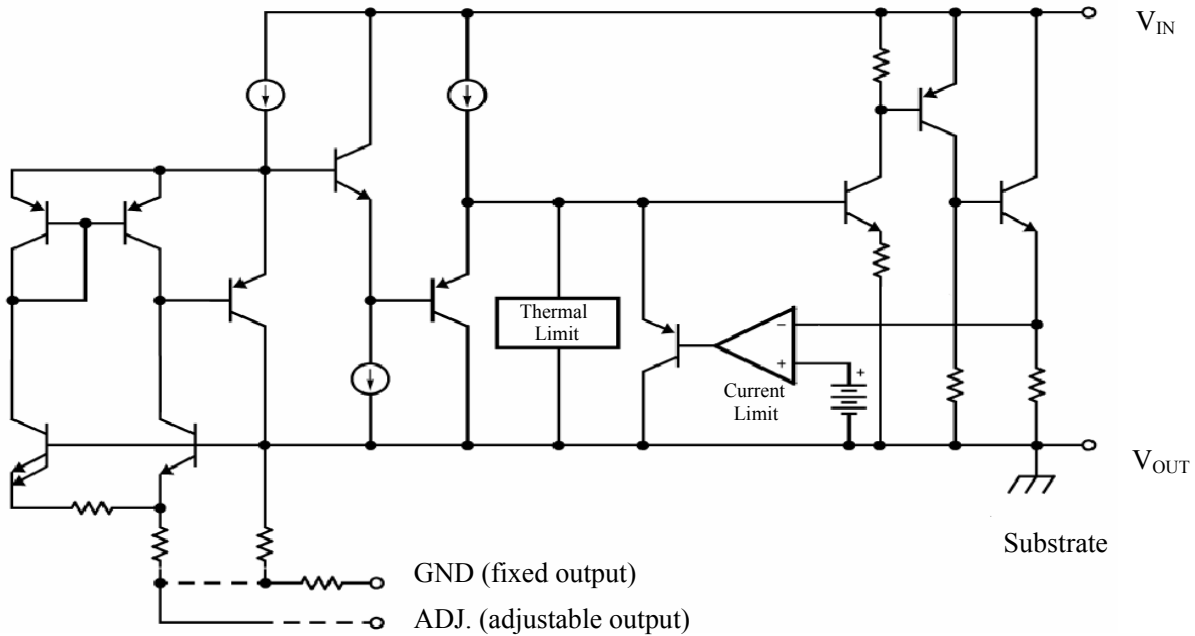

Figure 3. Block Diagram of IMP1117

Electrical Characteristic

Typicals and limits appearing in normal type apply for $T_J=25^\circ\text{C}$. Limits appearing in Boldface type apply over the entire junction temperature for operation, 0°C to 125°C .

Symbol	Parameter	Conditions	Min (Note 2)	Typ (Note 1)	Max (Note 2)	Units	
V_{REF}	Reference Voltage	IMP1117 $1.5\text{V} \leq (V_{IN} - V_{OUT}) \leq 7\text{V}, 10\text{mA} \leq I_{OUT} \leq 1\text{A}$	1.225	1.250	1.275	V	
V_{OUT}	Output Voltage	$10\text{mA} \leq I_{OUT} \leq 1\text{A}$	$I_{OUT} = 10\text{mA}, V_{IN} = 3.2\text{V}$	1.176	1.200	1.224	V
			IMP1117-1.2, $2.7\text{V} \leq V_{IN} \leq 8.2\text{V}$	1.152	1.200	1.248	V
			IMP1117-1.5, $3.0\text{V} \leq V_{IN} \leq 8.5\text{V}$	1.470	1.500	1.530	V
			IMP1117-1.8, $3.3\text{V} \leq V_{IN} \leq 8.8\text{V}$	1.764	1.800	1.836	V
			IMP1117-2.5, $4\text{V} \leq V_{IN} \leq 9.5\text{V}$	2.450	2.500	2.550	V
			IMP1117-2.85, $4.35\text{V} \leq V_{IN} \leq 9.85\text{V}$	2.793	2.850	2.907	V
			IMP1117-3.3, $4.8\text{V} \leq V_{IN} \leq 10.3\text{V}$	3.234	3.300	3.366	V
			IMP1117-5.0, $6.5\text{V} \leq V_{IN} \leq 12\text{V}$	4.900	5.000	5.100	V

1A Adjustable/Fixed Low Dropout Linear Regulator

Electrical Characteristic (Continued)

Typicals and limits appearing in normal type apply for $T_J=25^\circ\text{C}$. Limits appearing in Boldface type apply over the entire junction temperature for operation, 0°C to 125°C .

Symbol	Parameter	Conditions	Min (Note 2)	Typ (Note 1)	Max (Note 2)	Units
ΔV_{OUT}	Line Regulation (Note 3)	$I_{\text{OUT}}=10\text{mA}, (V_{\text{OUT}}+1.5\text{V})\leq V_{\text{IN}}\leq 12\text{V}$		0.035	0.2	%
	Load Regulation (Note 3)	$V_{\text{IN}}-V_{\text{OUT}}=2\text{V}, 10\text{mA}\leq I_{\text{OUT}}\leq 1\text{A},$ IMP1117-1.2		0.2	0.7	%
		$V_{\text{IN}}-V_{\text{OUT}}=2\text{V}, 10\text{mA}\leq I_{\text{OUT}}\leq 1\text{A},$		0.2	1	%
$V_{\text{IN}}-V_{\text{OUT}}$	Dropout Volage	$I_{\text{OUT}}=1\text{A}, \Delta V_{\text{REF}}=1\%$		1.100	1.250	V
I_{Limit}	Current Limit	$V_{\text{IN}}-V_{\text{OUT}}=2\text{V}, T_J=25^\circ\text{C}$	1.1	1.5		A
	Minimum Load Current (Note 4)	IMP1117-ADJ $1.5\text{V}\leq (V_{\text{IN}}-V_{\text{OUT}})\leq 10\text{V}$	10			mA
	Quiescent Curent	$V_{\text{IN}}=V_{\text{OUT}}+1.25\text{V}$		5	13	mA
	Thermal Regulation	$T_A = 25^\circ\text{C}, 30\text{ms pulse}$		0.01	0.1	%/W
	Ripple Rejection	$f=120\text{Hz}, V_{\text{IN}}-V_{\text{OUT}}=3\text{V}, V_{\text{Ripple}}=1\text{V}_{\text{PP}}$	60	72		dB
	Adjust Pin Current			50	120	μA
	Adjust Pin Current Change	$1.5\text{V}\leq V_{\text{IN}}-V_{\text{OUT}}\leq 7\text{V}, 10\text{mA}\leq I_{\text{OUT}}\leq 1\text{A}$		0.2	5	μA
	Temperature Stability			0.5		%
	Long Term Stability	$T_A = 125^\circ\text{C}, 1000\text{hrs.}$		0.3		%

1A Adjustable/Fixed Low Dropout Linear Regulator

Electrical Characteristic (Continued)

Typicals and limits appearing in normal type apply for $T_J=25^{\circ}\text{C}$. Limits appearing in Boldface type apply over the entire junction temperature for operation, 0°C to 125°C .

Symbol	Parameter	Conditions	Min (Note 2)	Typ (Note 1)	Max (Note 2)	Units
I_{Limit}	RMS Output Noise(% of V_{OUT})	$T_A = 25^{\circ}\text{C}$, $10\text{Hz} \leq f \leq 10\text{kHz}$		0.003		%
	Thermal Resistance, Junction to Case	SOT-223		15		$^{\circ}\text{C}/\text{W}$
		TO-252		3		$^{\circ}\text{C}/\text{W}$
	Thermal Shutdown	Junction Temperature		155		$^{\circ}\text{C}$
	Thermal Shutdown Hysteresis			25		$^{\circ}\text{C}$

Note 1: Typical Values represent the most likely parametric norm.

Note 2: All limits are guaranteed by testing or statistical analysis.

Note 3: Load and line regulation are measured at constant junction room temperature.

Note 4: The minimum output current required to maintain regulation.

Typical Performance Characteristics

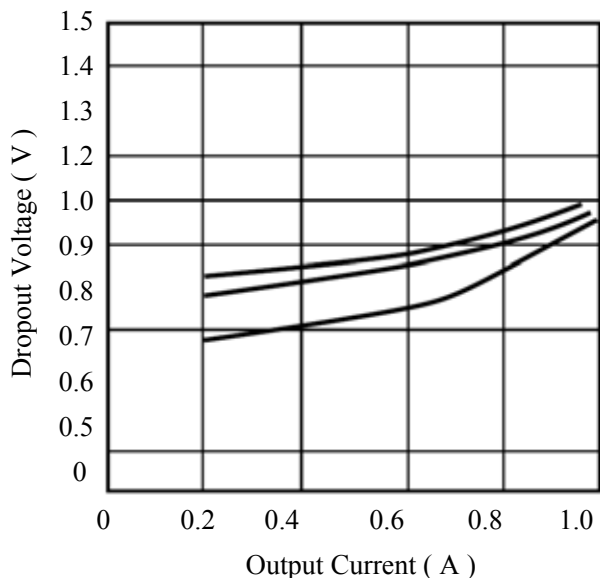

Figure 4. Dropout Voltage VS. Output Current

1A Adjustable/Fixed Low Dropout Linear Regulator

Typical Performance Characteristics

(Continued)

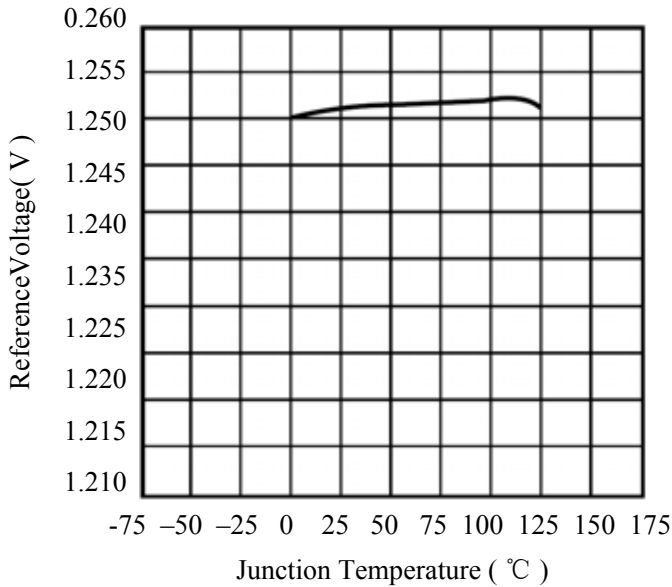

Figure 5. Reference Voltage VS. Temperature

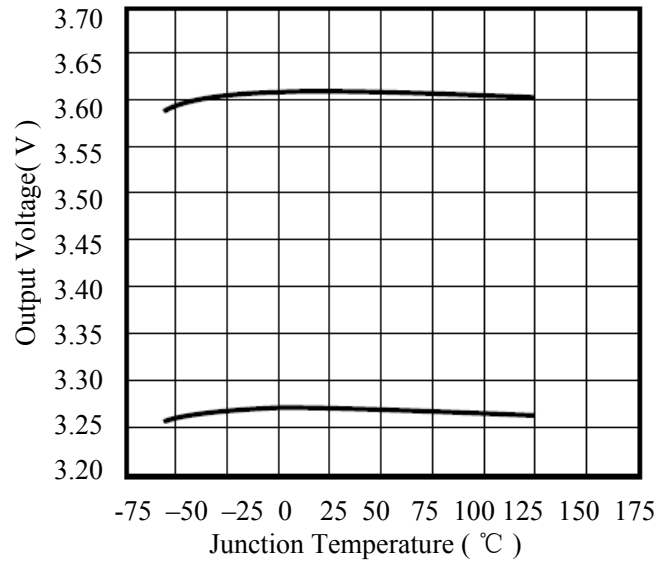

Figure 6. Output Voltage VS. Temperature

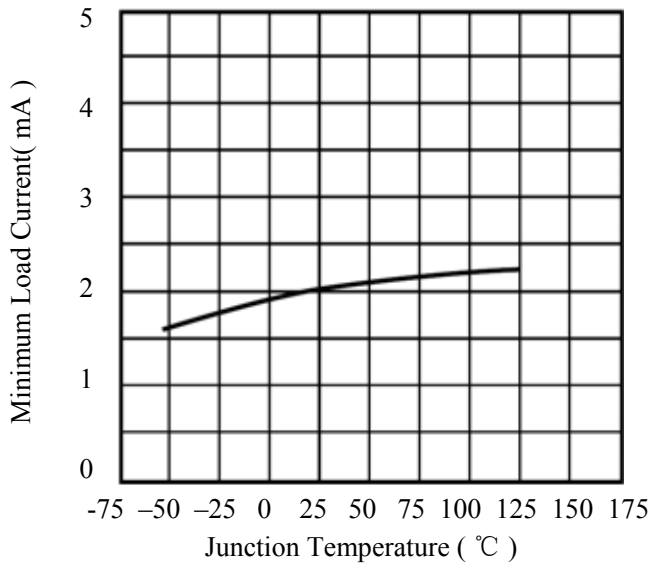

Figure 7. Minimum Load Current VS. Temperature

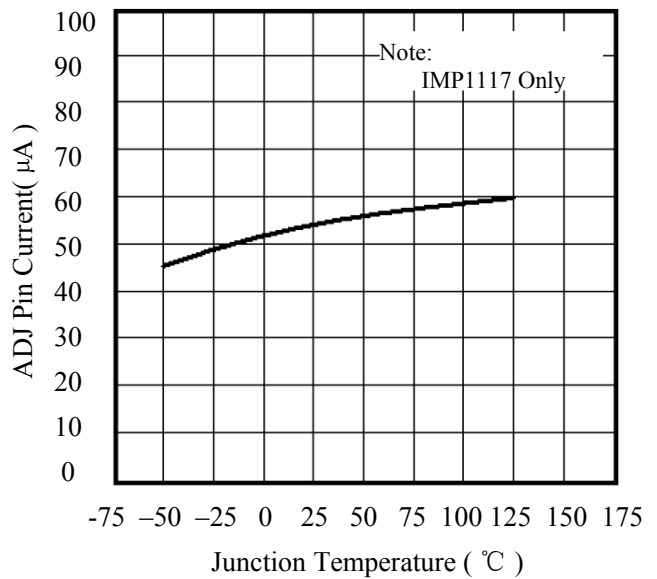

Figure 8. ADJ Pin Current VS. Temperature

1A Adjustable/Fixed Low Dropout Linear Regulator

Mechanical Dimensions

4-Lead SOT-223 Package

Symbol	Dimensions In Millimeters		Dimensions In Inches	
	Min	Max	Min	Max
A	1.520	1.800	0.060	0.071
A1	0.000	0.100	0.000	0.004
A2	1.500	1.700	0.059	0.067
b	0.660	0.820	0.026	0.032
c	0.250	0.350	0.010	0.014
D	6.200	6.400	0.244	0.252
D1	2.900	3.100	0.114	0.122
E	3.300	3.700	0.130	0.146
E1	6.830	7.070	0.269	0.278
e	2.300(BSC)		0.091(BSC)	
e1	4.500	4.700	0.177	0.185
L	0.900	1.150	0.035	0.045
θ	0°	10°	0°	10°

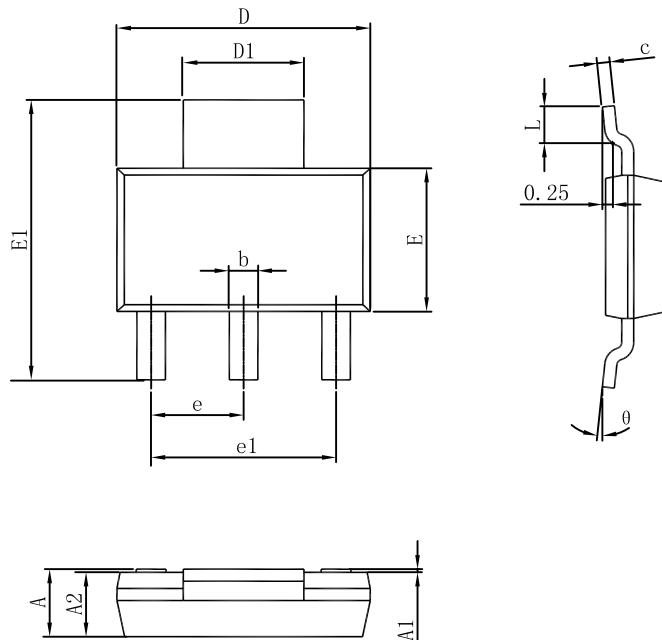

Figure 10. 4-Lead SOT-223 Package

1A Adjustable/Fixed Low Dropout Linear Regulator

Mechanical Dimensions

(Continued)

3-Lead TO-252 Package

Symbol	Inches		Millimeters		Notes
	Min.	Max.	Min.	Max.	
A	.086	.094	2.19	2.39	
b	.025	.035	0.64	0.89	
b2	.030	.045	0.76	1.14	
b3	.205	.215	5.12	5.46	4
c	.018	.024	0.46	0.61	
c2	.018	.023	0.46	0.58	
D	.210	.245	5.33	6.22	1
E	.250	.265	6.35	6.73	1
e	.090 BSC		2.29 BSC		
H	.370	.410	9.40	10.41	
L	.055	.070	1.40	1.78	3
L1	.108 REF		2.74 REF		
L3	.035	.080	0.89	2.03	4
L4	.025	.040	0.64	1.02	

Notes:

1. Dimensions are exclusive of mold flash, metal burrs or interlead protrusion.
2. Stand off-height is measured from lead tip with ref. to Datum -B-.
3. Foot length is measured with ref. to Datum -A- with lead surface.
4. Thermal pad contour optional within dimension b3 and L3.
5. Formed leads to be planar with respect to one another at seating place -C-.
6. Dimensions and tolerances.

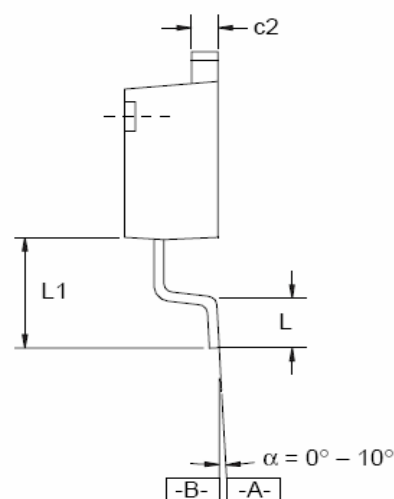
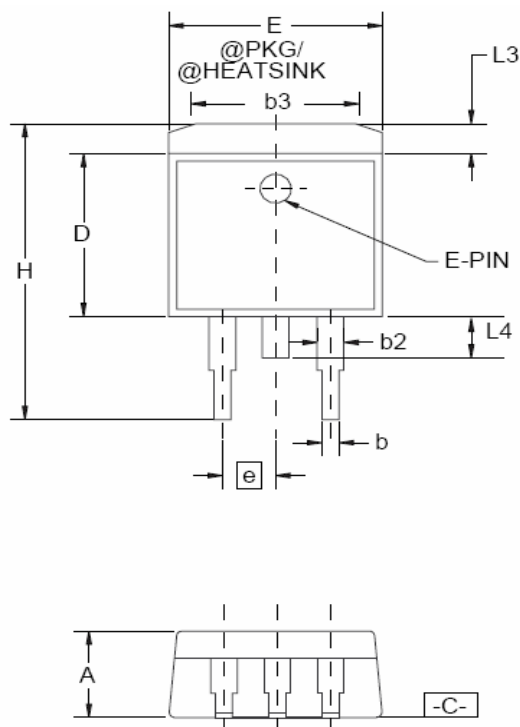

Figure 11. 3-Lead TO-252 Package

1A Adjustable/Fixed Low Dropout Linear Regulator

Ordering Information

Package	Temperature Range	Part Number	Output Voltage	Packing Marking	Transport Media
SOT-223	0°C - +125°C	IMP1117AS12X/T	1.2V	1117-S12	3K Tape and Reel
	0°C - +125°C	IMP1117AS15X/T	1.5V	1117-S15	3K Tape and Reel
	0°C - +125°C	IMP1117AS18X/T	1.8V	1117-S18	3K Tape and Reel
	0°C - +125°C	IMP1117AS25X/T	2.5V	1117-S25	3K Tape and Reel
	0°C - +125°C	IMP1117AS285/T	2.85V	1117-S28	3K Tape and Reel
	0°C - +125°C	IMP1117AS33/T	3.3V	1117-S33	3K Tape and Reel
	0°C - +125°C	IMP1117AS5X/T	5V	1117-S50	3K Tape and Reel
	0°C - +125°C	IMP1117ASX/T	Adjust	1117SADJ	3K Tape and Reel
TO-252	0°C - +125°C	IMP1117AD12X/T	1.2V	1117-D12	2.5K Tape and Reel
	0°C - +125°C	IMP1117AD15X/T	1.5V	1117-D15	2.5K Tape and Reel
	0°C - +125°C	IMP1117AD18X/T	1.8V	1117-D18	2.5K Tape and Reel
	0°C - +125°C	IMP1117AD25X/T	2.5V	1117-D25	2.5K Tape and Reel
	0°C - +125°C	IMP1117AD285/T	2.85V	1117-D28	2.5K Tape and Reel
	0°C - +125°C	IMP1117AD33/T	3.3V	1117-D33	2.5K Tape and Reel
	0°C - +125°C	IMP1117AD5X/T	5V	1117-D50	2.5K Tape and Reel
	0°C - +125°C	IMP1117ADX/T	Adjust	1117DADJ	2.5K Tape and Reel



ISO 9001 Registered

Daily Silver IMP Microelectronics Co.,Ltd
7 keda Road ,Hi-Tech Park,
NingBo,Zhejiang,P.R.C
Post Code:315040
Tel:(086)-574-87906358
Fax:(086)-574-87908866
Email:sales@ds-imp.com.cn
<http://www.ds-imp.com.cn>

©2010 Daily Silver IMP
Printed in china

Revision: G
Issue Date: 26th.Jul.10
Type: Product

The IMP logo is a registered trademark of Daily Silver IMP.
All other company and product names are trademarks of their respective owners

X-ON Electronics

Largest Supplier of Electrical and Electronic Components

Click to view similar products for [LDO Voltage Regulators](#) category:

Click to view products by [Daily Silver Imp](#) manufacturer:

Other Similar products are found below :

[AP7363-SP-13](#) [L79M05TL-E](#) [AP7362-HA-7](#) [PT7M8202B12TA5EX](#) [TCR3DF185,LM\(CT](#) [TCR3DF45,LM\(CT](#) [TLE4473G V52](#) [059985X](#)
[NCP4687DH15T1G](#) [701326R](#) [NCV8170AXV250T2G](#) [AP7315-25W5-7](#) [AP2111H-1.2TRG1](#) [ZLDO1117QK50TC](#) [AZ1117ID-ADJTRG1](#)
[TCR3DG12,LF](#) [MIC5514-3.3YMT-T5](#) [SCD7912BTG](#) [NCP154MX180270TAG](#) [SCD33269T-5.0G](#) [NCV8170BXV330T2G](#)
[NCV8170BMX330TCG](#) [NCV8170AMX120TCG](#) [NCP706ABMX300TAG](#) [NCP153MX330180TCG](#) [NCP114BMX075TCG](#) [MC33269T-3.5G](#)
[CAT6243-ADJCMT5T](#) [TCR3DG33,LF](#) [TCR4DG35,LF](#) [TAR5S15U\(TE85L,F\)](#) [TAR5S18U\(TE85L,F\)](#) [TCR3UG19A,LF](#) [TCR4DG105,LF](#)
[MPQ2013AGG-5-P](#) [NCV8170AMX360TCG](#) [TLE4268GSXUMA2](#) [NCP715SQ15T2G](#) [MIC5317-3.0YD5-T5](#) [NCV563SQ18T1G](#)
[NCP715MX30TBG](#) [NCV8702MX25TCG](#) [NCV8170BXV120T2G](#) [MIC5317-1.2YD5-T5](#) [NCV8170AMX150TCG](#) [NCV8170BMX150TCG](#)
[AP2213D-3.3TRG1](#) [NCV8170BMX120TCG](#) [NCV8170BMX310TCG](#) [NCV8170BMX360TCG](#)