

Multi-Layer Power Inductors (IP Series)

For DC/DC Converter Application

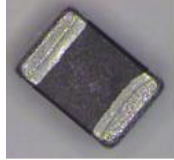

ORDERING CODE

IP 2012 1R0 M P S 9

PRODUCT CODE _____

IP : Multilayer Power Inductor (Lead Free)

DIMENSION (L X W) _____

Code	Dimension	EIA
1608	1.6 x 0.80 mm	0603
2012	2.0 X 1.25 mm	0805
2016	2.0 X 1.6 mm	0806
2520	2.5 X 2.0 mm	1008

INDUCTANCE CODE _____

Code	R47	1R0	1R5	2R2	3R3	4R7
Inductance (uH)	0.47	1.0	1.5	2.2	3.3	4.7

TOLERANCE CODE _____

M: ±20%

PACKAGING CODE _____

T: Paper tape reel
P: Embossed reel

SPECIFICATION CODE _____

S: Standard for DC/DC converter
L: Light loading current for choke
C: High Current Type

THICKNESS CODE _____

Code	5	7	8	9	B	C
Thickness (mm)	0.5	0.7	0.8	0.9	1.1	1.2

Standard External Dimensions

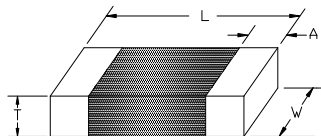

Unit: mm

Series	L	W	T	A (Min/Max)
IP1608 (0603)	1.6±0.15	0.8±0.15	0.95 max	0.1/0.5
IP2012 (0805)	2.0±0.2	1.25±0.2	1.0 max	0.20/0.80
IP2016 (0806)	2.0±0.2	1.6±0.2	1.0 max	0.20/0.80
IP2520 (1008)	2.5±0.2	2.0±0.2	1.0 max	0.20/0.80

Recommended Pad Dimensions

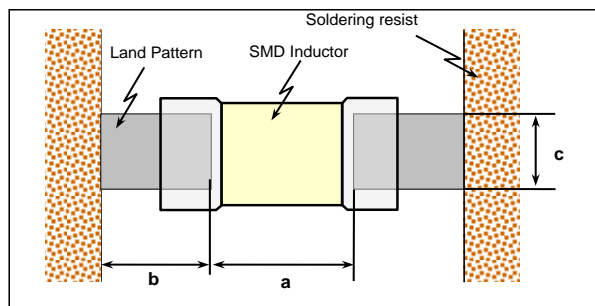

Size mm (EIA)	L x W (mm)	a (mm)	b (mm)	c (mm)
1608 (0603)	1.6 x 0.8	0.8 to 1.0	0.6 to 0.8	0.6 to 0.8
2012 (0805)	2.0 x 1.25	0.8 to 1.2	0.8 to 1.2	0.9 to 1.6
2016 (0806)	2.0 x 1.6	0.8 to 1.2	0.8 to 1.2	0.9 to 1.6
2520 (1008)	2.5 x 2.0	1.0 to 1.4	0.6 to 1.0	1.8 to 2.2

Unit: mm/(inch)

Power Inductor for DC/DC converter

■ Feature

1. Small and light weight
2. Low DC resistance
3. RoHS complaint

■ Application

DC/DC converter for the Mobile equipment; Mobile Phone, DSC, WLAN

■ Part Numbers & Characteristic

● IP1608 (EIA 0603)

Type	Ordering Code	Inductance		Measuring frequency [MHz]	DCR (ohm)		Rated Current [A]		Saturation Current [A]		SRF (MHz.)	Thickness (mm)	Packing
		[uH]	Tol		Max.	Typ.	Max.	Typ.	Max.	Typ.	Min.		
Standard	IP1608R50MTS8	0.50	±20%	1	0.150	0.120	0.90			0.80	200	0.80 ±0.15	7" Paper 4kpcs
	IP16081R0MTS8	1.0			0.200	0.170	0.75			0.50	140		
	IP16082R2MTS8	2.2			0.300	0.270	0.65			0.25	80		

※Operating temperature range from -40°C to 85°C.

● IP2012 (EIA 0805)

Type	Ordering Code	Inductance		Measuring frequency [MHz]	DCR (ohm)		Rated Current [A]		Saturation Current [A]		SRF (MHz.)	Thickness (mm)	Packing
		[uH]	Tol.		Max.	Typ.	Max.	Typ.	Max.	Typ.	Min.		
Standard ^{#1}	IP2012R47MPS9	0.47	±20%	1	0.080	0.060	1.20			1.20	160	0.90 ±0.10	7" Embossed 3 kpcs
	IP20121R0MPS9	1.0			0.140	0.110	1.00			1.10	120		
	IP20121R5MPS9	1.5			0.200	0.150	0.80			0.90	95		
	IP20122R2MPS9	2.2			0.200	0.150	0.80			0.45	70		
	IP20123R3MPS9	3.3			0.240	0.200	0.70			0.30	70		
	IP20124R7MPS9	4.7			0.280	0.230	0.70			0.18	60		

※Operating temperature range from -40°C to 85°C.

● IP2016 (EIA 0806)

Type	Ordering Code	Inductance		Measuring Frequency [MHz]	DCR (ohm)		Rated Current [A]		Saturation Current [A]		SRF (MHz.)	Thickness (mm)	Packing
		[uH]	Tol.		Max.	Typ.	Max.	Typ.	Max.	Typ.			
Standard ^{#1}	IP2016R47MPS9	0.47	±20%	1	0.075	0.060	1.60			1.20	150	0.90 ±0.10	7" Embossed 3 kpcs
	IP20161R0MPS9	1.0			0.120	0.090	1.30			1.10	100		
	IP20161R5MPS9	1.5			0.130	0.100	1.20			0.80	85		
	IP20162R2MPS9	2.2			0.140	0.110	1.20			0.60	65		
	IP20163R3MPS9	3.3			0.160	0.130	1.10			0.30	65		
	IP20164R7MPS9	4.7			0.200	0.160	0.90			0.20	55		

※Operating temperature range from -40°C to 85°C.

● IP2520 (EIA 1008)

Type	Ordering Code	Inductance		Measuring frequency [MHz]	DCR (ohm)		Rated Current [A]		Saturation Current [A]		SRF (MHz.)	Thickness (mm)	Packing
		[uH]	Tol.		Max.	Typ.	Max.	Typ.	Max.	Typ.			
Standard	IP2520R47MPS9	0.47	±20%	1	0.050	0.040	1.80		1.28	1.60	100	0.90 ±0.10	7" Embossed 3 kpcs
	IP25201R0MPS9	1.0			0.080	0.065	1.40		0.96	1.20	95		
	IP25201R5MPS9	1.5			0.090	0.075	1.30		0.64	0.80	80		
	IP25202R2MPS9	2.2			0.090	0.075	1.30		0.56	0.70	60		
	IP25203R3MPS9	3.3			0.120	0.090	1.20		0.24	0.30	55		
	IP25204R7MPS9	4.7			0.150	0.120	1.10		0.24	0.30	45		

※Operating temperature range from -40°C to 85°C.

※Rated current specifies that temperature rise caused by self-generated heat shall be limited to 40°C max

※Saturated current specifies that inductance drop is below 30% during DC loaded (at 20°C)

Testing Condition & Requirements (IP Series)

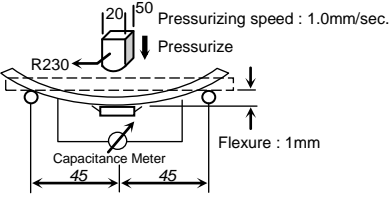
No.	Item	Test Condition	Requirements
1	Appearance	Inductors shall be visually inspected for visible evidence of defect.	No harmful defect for piratical use.
2	Inductance	a. Temperature: 25+/- 3°C b. Relative Humidity: 45 to 75%RH c. Measuring equipment: HP4285A(HP42841A、HP42842C) Measuring Jig: HP42851-61100	Within specified tolerance.
3	DC Resistance	Measuring instrument: VOAC-7510	In accordance with electrical specification.
4	Dimension	Dimension shall be measured with caliper or micrometer	In accordance with dimension specification.
5	Solder-ability	Immerse a test sample into a methanol solution containing rosin and immerse into Pd-free solder(Sn96.5Ag3.0Cu0.5) solder of 245±3°C for 4±1 seconds.	90% of the termination is to be soldered evenly and continuously.
6	Resistance to Soldering Heat	Immerse a test sample into a methanol solution containing resin, preheat it at 150 to 180°C for 2~3 minutes and immerse into molten solder of 260+/-5°C for 10+/-0.5 second so that both terminal electrodes are completely submerged. After this test samples shall be taken out and measured after kept at room temperature for 2 to 3 hours.	No visible damage Inductance variation within 30%
7	Bending Strength	Solder the chip to test jig then apply a force in the direction shown in below. The soldering shall be done with the reflow method and shall be conducted with care so that the soldering is uniform and free of defects such as heat shock. 	No mechanical damage shall be observed.
8	Thermal Shock	Solder a test sample to printed circuit board, and conduct 5 cycles of test under the conditions shown as below. Condition for 1 cycle Step1:-40+0/ -3°C 30±3 min. Step2: Room temperature within 2 to 3 min. Step3:+85 +3/ -0°C 30±3 min. Step4: Room temperature within 2 to 3 min. Measured at room temperature after placing for 2 to 3 hrs.	No visible damage Inductance variation within 30%

No.	Item	Test Condition	Requirements
9	High Humidity State Life Test	Keep a test sample in an atmosphere with a temperature of $40\pm 2^{\circ}\text{C}$, 90~95%RH for 500 +24/-0 hours. After the removal from test chamber, 2 to 3 hours of recovery under standard condition, and measurement shall be made after 24 ± 2 hrs of recovery under standard condition.	No visible damage. Inductance variation within 30%.
10	High Humidity Load Life Test	Solder a test sample to printed circuit board then keep the test sample in an atmosphere with a temperature of $40\pm 2^{\circ}\text{C}$, 90~95%RH for 500+24/-0 hours while supplying the rated current. After the removal from test chamber, 2 to 3 hours of recovery under standard condition, and measurement shall be made after 24 ± 2 hrs of recovery under standard condition.	No visible damage. Inductance variation within 30%.
11	High Temperature State Life Test	Keep a test sample in an atmosphere with a temperature of $85\pm 3^{\circ}\text{C}$ for 500+24/-0 hours. After the removal from test chamber, 2 to 3 hours of recovery under standard condition, and measurement shall be made after 24 ± 2 hrs of recovery under standard condition.	No visible damage. Inductance variation within 30%.
12	High Temperature Load	Solder a test sample to printed circuit board then keep the test sample in an atmosphere with a temperature of $85\pm 3^{\circ}\text{C}$ for 500+24/-0 hours while supplying the rated current. After the removal from test chamber, 2 to 3 hours of recovery under standard condition, and measurement shall be made after 24 ± 2 hrs of recovery under standard condition.	No visible damage. Inductance variation within 30%.

Reflow Profile Chart (Reference)

● **Wave Soldering**

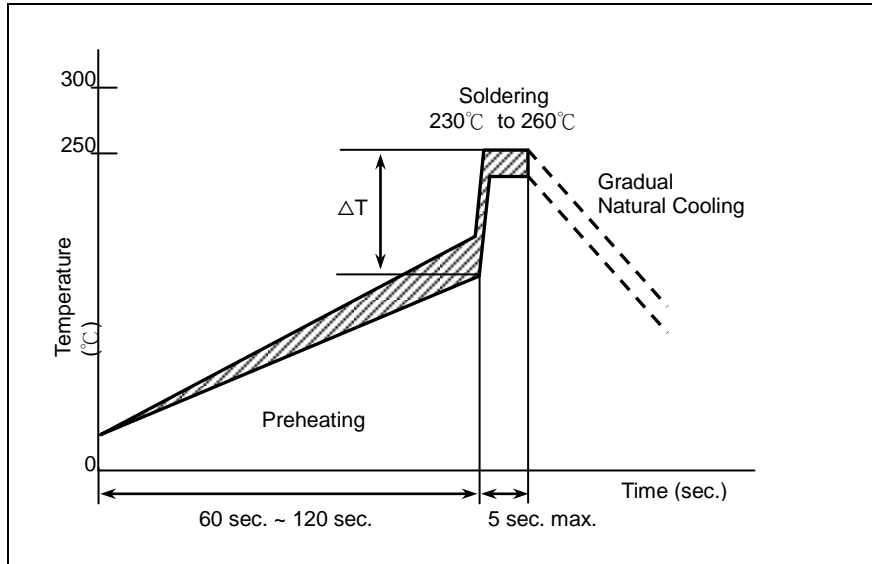

Chip Size	3216 and smaller	3225 and above
Preheating	$\Delta T \leq 150^{\circ}\text{C}$	-

● **Soldering Iron**

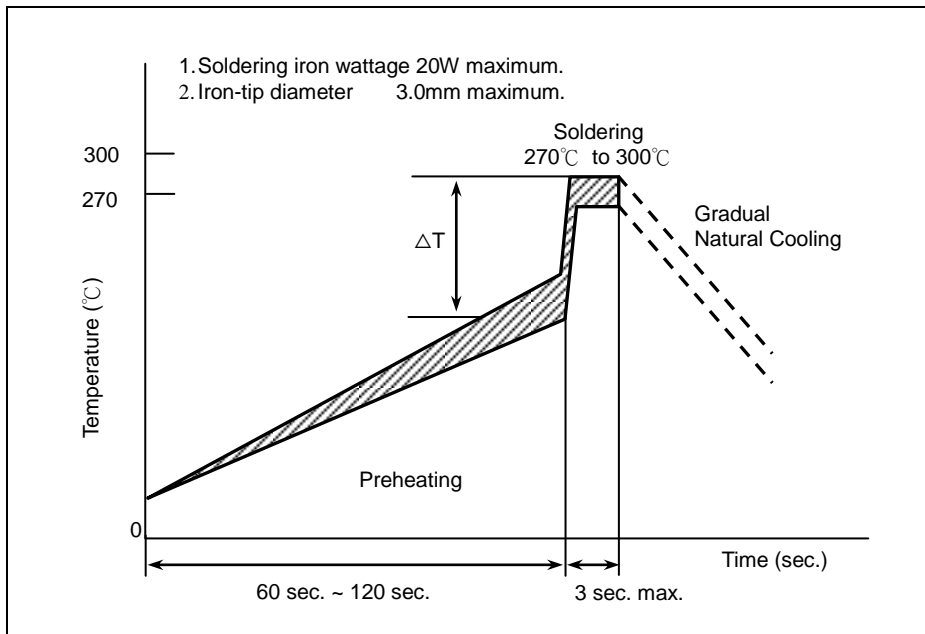

Chip Size	3216 and smaller	3225 and above
Preheating	$\Delta T \leq 190^{\circ}\text{C}$	$\Delta T \leq 130^{\circ}\text{C}$

● **Soldering Profile for SMT Process with Lead Free Solder Paste.**

The rate of preheat should not exceed 4°C/sec and a target of 2°C/sec is preferred. Ceramic chip components should be preheated to within 100 to 130 °C of the soldering.

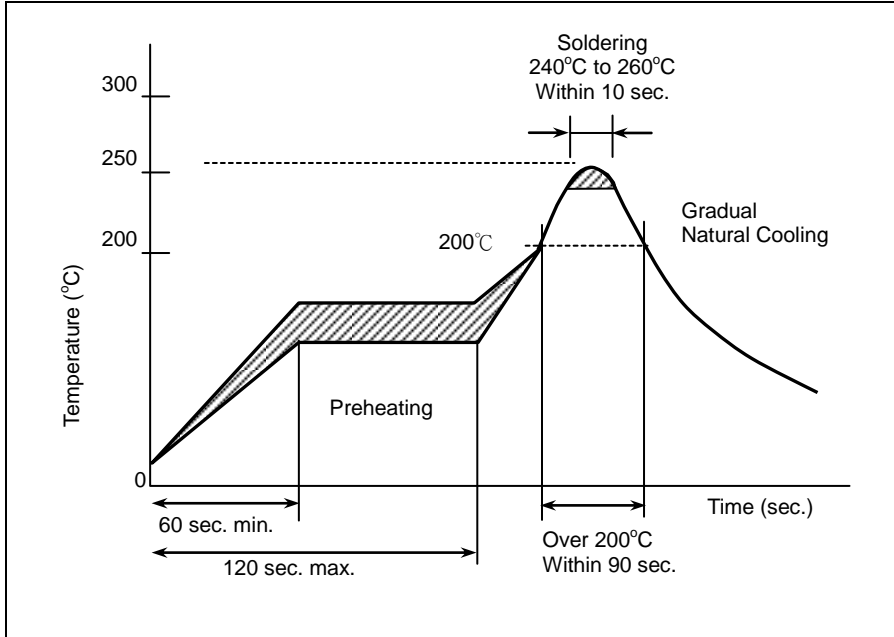

● **Soldering Profile for SMT Process with SnPb Solder Paste.**

The rate of preheat should not exceed 4°C/sec and a target of 2°C/sec is preferred. Ceramic chip components should be preheated to within 100 to 130°C of the soldering.

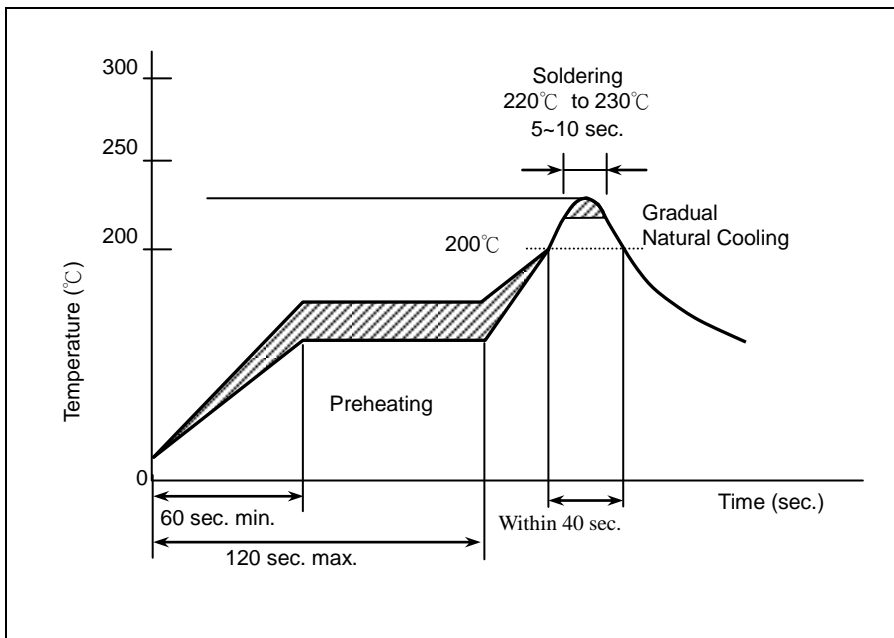

Packaging Specification

- Paper Tape

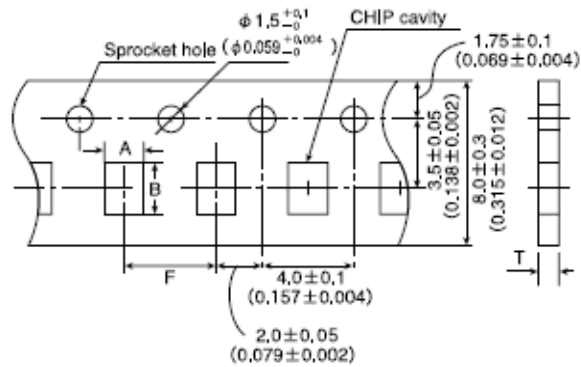

	Symbol	Product Size Code			
		0603(0201)	1005(0402)	1608(0603)	2012(0805)
		(mm)	(mm)	(mm)	(mm)
Chip cavity	A	0.38±0.02	0.62±0.03	1.0 ±0.2	1.5 ±0.2
	B	0.68±0.02	1.12±0.03	1.8 ±0.2	2.3 ±0.2
Insertion Pitch	F	2±0.1	2±0.1	4.0 ±0.1	4.0 ±0.1
Tape Thickness	T	1.1 max	1.1 max	1.1 max	0.8 max

- Embossed Tape

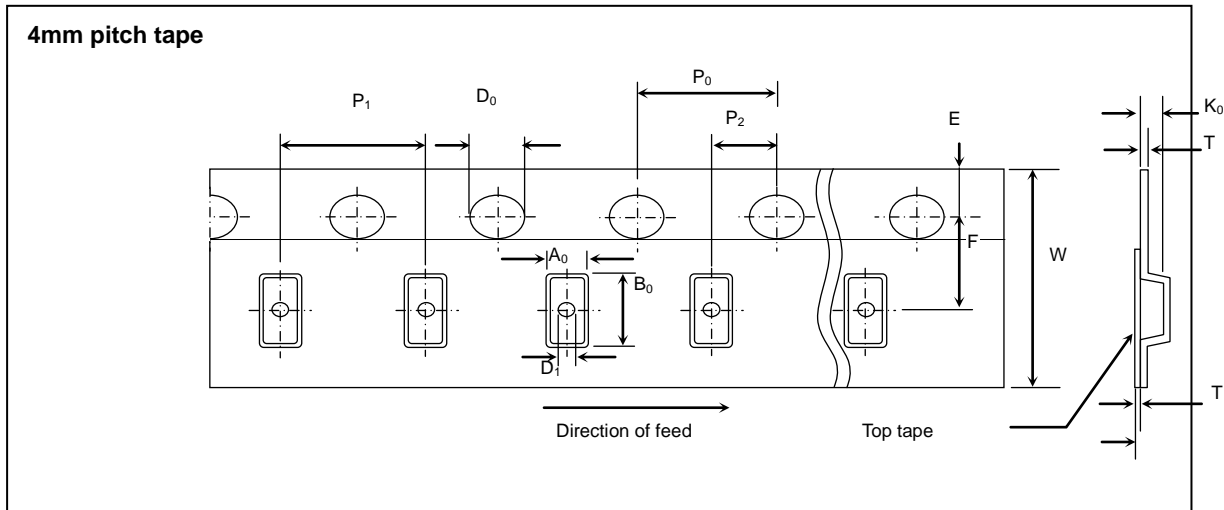

Symbol	1608(0603)	2012 (0805)	2016 (0806)	2520 (1008)
P_1	4±0.1	4±0.1	4±0.1	4±0.1
P_0	4±0.1	4±0.1	4±0.1	4±0.1
P_2	2±0.05	2±0.05	2±0.05	2±0.05
A_0	1.0±0.1	1.55±0.2	1.8±0.1	2.3±0.1
B_0	1.8±0.1	2.3±0.2	2.2±0.1	2.8±0.1
K_0	1.0 Max	1.3±0.1	1.3±0.1	1.4±0.1
W	8±0.3	8±0.3	8±0.3	8±0.3
E	1.75±0.1	1.75±0.1	1.75±0.1	1.75±0.1
F	3.5±0.05	3.5±0.05	3.5±0.05	3.5±0.05
D_0	1.5 (+0.1/-0.0)	1.5 (+0.1/-0.0)	1.5 (+0.1/-0.0)	1.5 (+0.1/-0.0)
T	0.3 ±0.05	0.3 max	0.3 max	0.3 max

Unit: mm/(inch)

● **Reel Specifications**

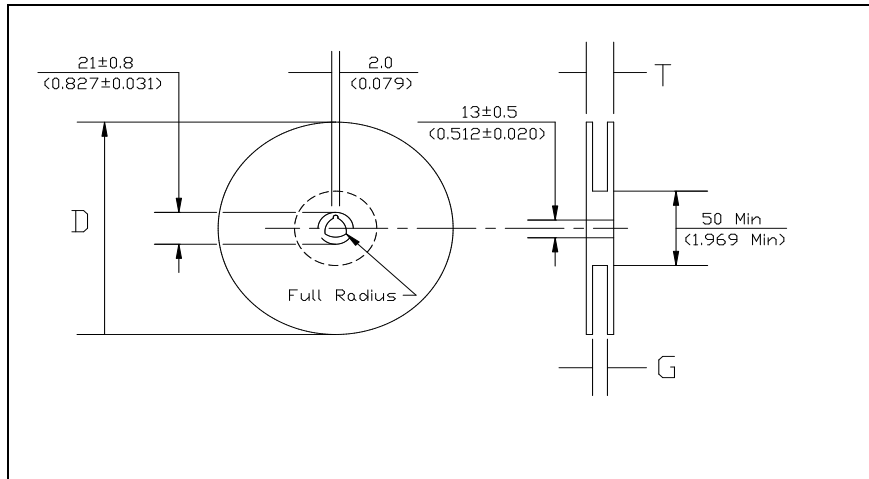

Tape Width (mm)	G (mm)	T max.(mm)	D (mm)
8	10.0±1.5	14.5	178±2.0

● **Packing Rule**

EIA SIZE	Tape	Reel Size	Reels/Box	Boxes/ Carton
0402	Paper	7"	5	12
0603	Paper/Emboss	7"	5	12
0805	Paper/Emboss	7"	5	12
0806	Paper/Emboss	7"	5	12
1008	Paper/Emboss	7"	5	12

● **Peel Strength of Top Cover Tape**

The peel speed shall be about 300 mm/min.

The peel strength of top cover tape shall be between 0.1 to 1.0N.

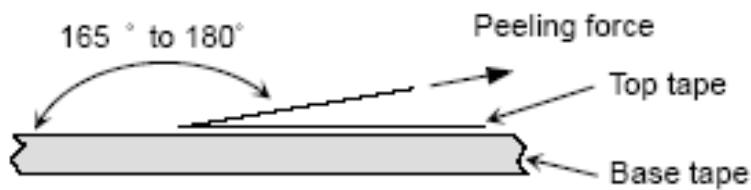

Label Information



Cautions

● Storage

1. The inductor shall be packaged in carrier tapes.
2. To keep storage place temperature from +5 to 35°C, humidity from 45 to 70% RH.
3. The storage atmosphere must be free of gas containing sulfur and chlorine. Also, avoid exposing the product to saline moisture. If the product is exposed to such atmospheres, the terminals will oxidize and solderability will be affected.
4. The solder ability is assured for 12 months from our final inspection date if the above storage condition is followed.

● Handling

Inductor should be handled with care to avoid contamination or damage. The use of vacuum pick-up or plastic tweezers is recommended for manual placement. Tape and reeled packages are suitable for automatic pick and placement machine.

X-ON Electronics

Largest Supplier of Electrical and Electronic Components

Click to view similar products for [darfon](#) manufacturer:

Other Similar products are found below :

[SPS30301R0MPCC](#) [C1005X7R151MGTS](#) [C1005NP0309BGTS](#) [C1005NPO509CGT](#) [C1005X7R223MGTS](#) [C0603NP0330JFT](#)
[C2012X7R104KHPS](#) [C1608X7R473KGTS](#) [C2012NP0101JGTS](#) [C1005X7R104METS](#) [C1005NP0208AGTS](#) [C0603NP0309CGTS](#)
[C1005NP0160KGTS](#) [C0603NP0759CGTS](#) [C1608X7R104MGTS](#) [C2012X7R102KKTS](#) [SPN30302R2MPTE](#) [C1005NP0339BGTS](#)
[C0603NP0708CGTS](#) [C1005NP0201JGTS](#) [C1005X7R102KGT](#) [C1005NP0249CGTS](#) [SPN3030100MPTE](#) [C0603NP0708BGTS](#)
[C1005X5R103KGTS](#) [C0603X7R102KGTS](#) [SPN30301R0NPTE](#) [C1005NP0909DGTS](#) [C1005NPO680JGTS](#) [C1608X7R102KGTS](#)
[C3216NP0101JPPS](#) [C0603NPO330JFT](#) [PGNR201610-2R2M](#) [C1005NP0109BGTS](#) [C0603X7R822KDTS](#) [C1005NP0110KGTS](#)
[C1005NP0101JGTS](#) [C1005X7R181KGTS](#) [C1608NP0470JGTS](#) [C1005NP0209BGTS](#) [C1005X5R104MFTS](#) [C1005NP0240JGTS](#)
[C0603X5R104KCTS](#) [C3216X7R471KPPS](#) [C0603X5R474KCTS](#) [C2012X7R103KGTS](#) [C0603NP0100GGTS](#) [IP20164R7MPS9](#)
[C3216X7R472KLPS](#) [C1005X5R224METS](#)