

PART NAME: KNOB SCALE: 2:1 DATE: 9/10/95 DR. BY RF

THIS DRAWING IS THE PROPERTY OF DAVIES MOLDING COMPANY, IS SUBMITTED SOLELY AS A DESIGN OR ENGINEERING PROJECT. WE ACCEPT NO RESPONSIBILITY WHATSOEVER FOR THE PRACTICAL APPLICATION OF THE PIECES MADE TO THIS DESIGN.

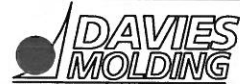

DESIGNERS & MANUFACTURERS OF KNOBS, HANDLES, CASES & CUSTOM PLASTIC COMPONENTS

P/N 3038-B

M NO. (8) CAV.MUD

CAVITY	3038
CORE	3038
SLEEVE	3038
PIN	3038
BUSHING	3038-G
PIN BAR	3038
CAVITY PLUG	3038-B
INSERT	11957

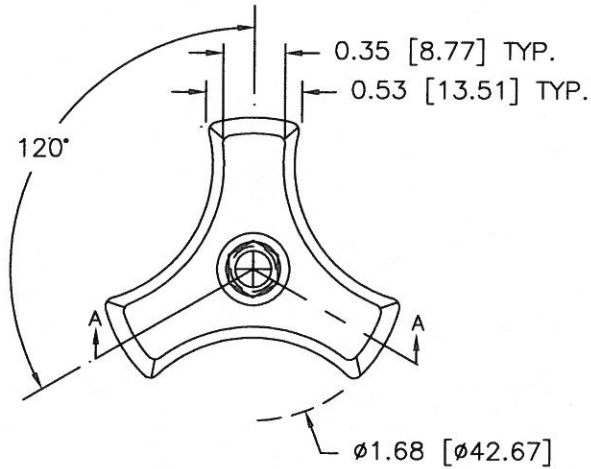

Ⓑ
Ⓔ

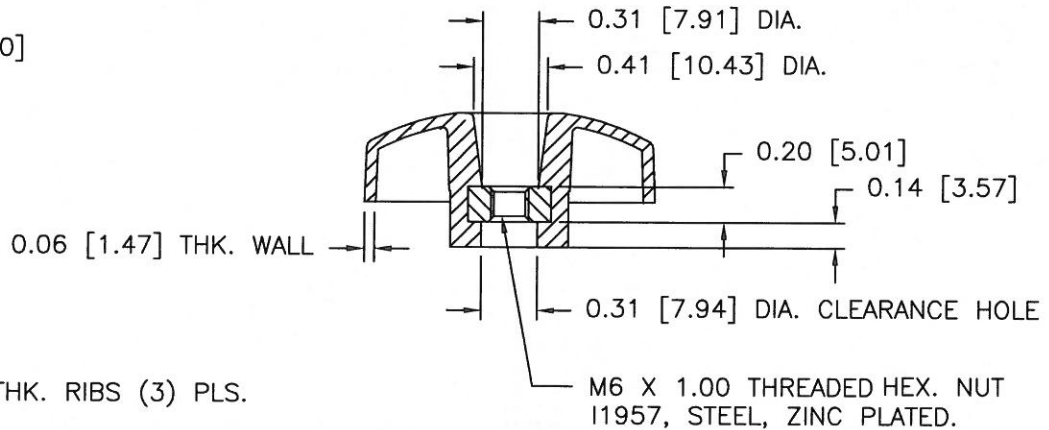
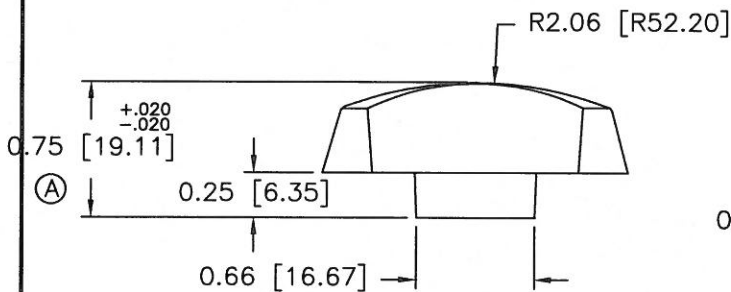

SECTION 'A-A'

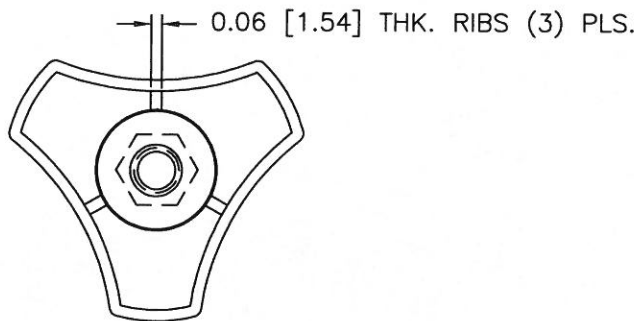

Ⓓ MATERIAL: 20% Talc Filled Polypropylene
COLOR: Black

<p>TOLERANCES: UNLESS OTHERWISE SPECIFIED</p> <p>DECIMALS: X.XXX ± .005 X.XX ± .015</p> <p>FRACTIONS ± 1/64</p>	<p>DO NOT SCALE DRAWING</p> <p>MM: X.XX ± 0.15MM X.X ± 0.4MM</p> <p>ANG. ± 1°</p>	E	ADDED BUSHING	ST	7/09/01
		D	WAS HIPS	TL	4/20/99
		C	MAT'L REVI WAS POLYPROPYLENE	HD	1/29/96
		B	WAS #3038-B PINS	HD	1/10/96
		A	UPDATED DWG. W/ ADDED TOLERANCES	HD	12/13/95
CHANGES					

X-ON Electronics

Largest Supplier of Electrical and Electronic Components

Click to view similar products for [Knobs & Dials](#) category:

Click to view products by [Davies Molding](#) manufacturer:

Other Similar products are found below :

[8519](#) [8547](#) [8573](#) [11K5015-EMNB](#) [11K5019-ECNB](#) [11K5020-KLAB](#) [11K5048-KMNB](#) [11K5014-EMNB](#) [11K5015-EMNG](#) [11K5019-EMNB](#) [1770](#) [P400S-08-D6-N](#) [K6510](#) [PKJ50B18](#) [42000B38](#) [420114B14](#) [5006](#) [KS700B14](#) [411](#) [420037B14](#) [8517](#) [8545](#) [8546](#) [8572](#) [H-516-3A](#) [P861H-0X-S6](#) [8544](#) [11K5014-JMNG](#) [11K5014-KMNG](#) [11K5014-ECNG](#) [5700E](#) [5002-5](#) [52-928.40](#) [5003-5](#) [11K5019-KCNG](#) [11K5028-KCNG](#) [02000-11A-2](#) [02000-4-1](#) [0025DF](#) [G813512LADUS-0](#) [2810-Y](#) [3009CC](#) [3025BA](#) [YME IP 12 D](#) [YME IP 01 A](#) [YME IP 12 H](#) [YME IP 12L-U](#) [YME IP 16 I](#) [YME IP 01 B](#) [YME IP 16 N](#)