

# 承認書

## SPECIFICATION FOR APPROVAL

CUSTOMER: 2144

DESCRIPTION: COMMON MODE CHOKE

DDY PART NO: WBA0603D900PT-F-HF

CUSTOMERMODELNO: \_\_\_\_\_

DRAWING		
MADE	CHECKED	APPROVED
譚晶晶	黃志偉	肖中華
DATE:	2023年7月6日	

CUSTOMER APPROVE

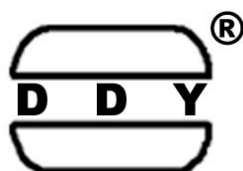

惠州市德立电子有限公司  
HUI ZHOU DE LI ELECTRONICS CO., LTD

廣東省博羅縣洲際工業園梅園三路  
NO.3 MEI YUAN ROAD,ZHOU JI INDUSTRIAL AREA,BOLUO COUNTY GUANGDONG

電話: 15970768093 13640935893

傳真: 0752-6207969

郵編: 516100

Http://ddycoils.com



惠州市德立电子有限公司

HUI ZHOU DE LI ELECTRONICS CO., LTD

CUSTOMER:	2144	REV NO:	A
DESCRIPTION:	COMMON MODE CHOKE	PAGE NO:	PAGE 1 OF 6
PART NO:	WBA0603D900PT-F-HF	SN.	
CUSTOMER NO:		DATE:	2023年7月6日

# CATALOG

Resume	.....	P2
Shape & Dimension	.....	P3
Characteristic	.....	P3
Part numbering ststem	.....	P3
General specification	.....	P3
Soldering Conditions	.....	P4
Material List	.....	P4
Package Information	.....	P5
Electrical Characteristic Curve	.....	P6





惠州市德立电子有限公司  
HUI ZHOU DE LI ELECTRONICS CO., LTD

CUSTOMER:	2144	REV NO:	A
DESCRIPTION:	COMMON MODE CHOKE	PAGE NO:	PAGE 3 OF 6
PART NO:	WBA0603D900PT-F-HF	SN.	
CUSTOMER NO:		DATE:	2023年7月6日

**1. SHAPE & DIMENSION**

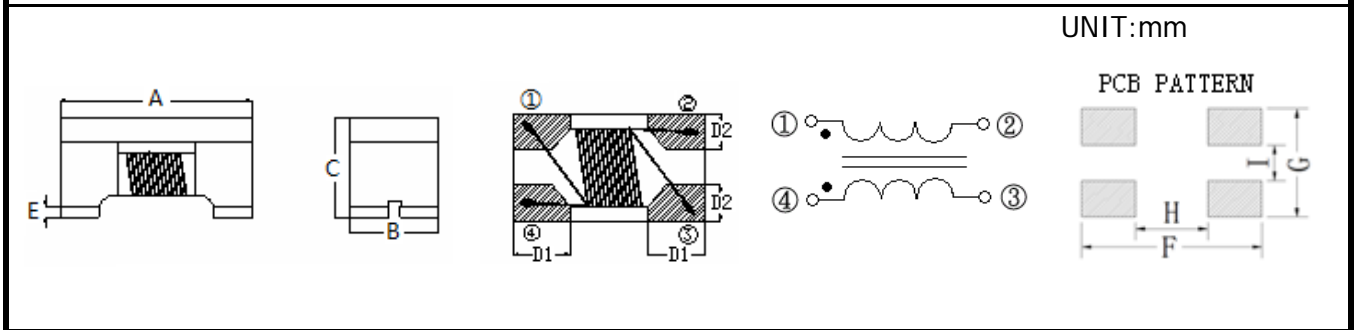

CODE	A	B	C	E	D1	D2	F	G	H	I
DIMENSION	1.6±0.1	0.8±0.1	1.1±0.1	0.1 Max	0.33 Typ.	0.25 Typ.	1.89 Typ.	0.85 Typ.	0.73 Typ.	0.25 Typ.

**2. ELECTRICAL CHARACTERISTICS @25°C**

Part Number	Z	Freq	Rdc	Irms	Rated Voltage	Insulation Resistance
	(Ω)	(MHz)	(Ω)max	(mA)max	Volts	MΩ Min
WBA0603D900PT-F-HF	90	100	0.25	300	20	10

**3. PART NUMBERING SYSTEM**

**WBA** □□□□ □ □□□ □ □ — □□  
**1**    **2**            **3**        **4**        **5**    **6**        **7**

- PRODUCT SYMBOL (产品代号)
- DIMENSIONS (规格尺寸)
- TYPE (类型)
- IMPEDANCE (阻抗)
- TOLERANCE (公差) : P±25%; N±30%
- PACKAGING (包装方式) : T-编带盘装; B-散装
- E.P. (环保) : LF—Lead Free HF—Halogen Free FP—Red Phosphor Free

**4. GENERAL SPECIFICATION**

- Rating DC current: Temperature rise(ΔT) is 40°C approximately at Irms.
- Operating temp.: -40°C~ +85°C
- Storage temp.: -10°C ~ +40°C R.H.: 65% Max
- Moisture sensitivity level (MSL) 2 (1 year floor life at <30°C/65% relative humidity)

APPROVED BY	CHECKED BY	DRAFT
肖中华	黄志伟	谭晶晶



**惠州市德立电子有限公司**  
**HUI ZHOU DE LI ELECTRONICS CO., LTD**

CUSTOMER:	2144	REV NO:	A
DESCRIPTION:	COMMON MODE CHOKE	PAGE NO:	PAGE 4 OF 6
PART NO:	WBA0603D900PT-F-HF	SN.	
CUSTOMER NO:		DATE:	2023年7月6日

**5. SOLDERING CONDITIONS**

**Figure 1.  
Re-flow  
Soldering (Lead  
Free)**

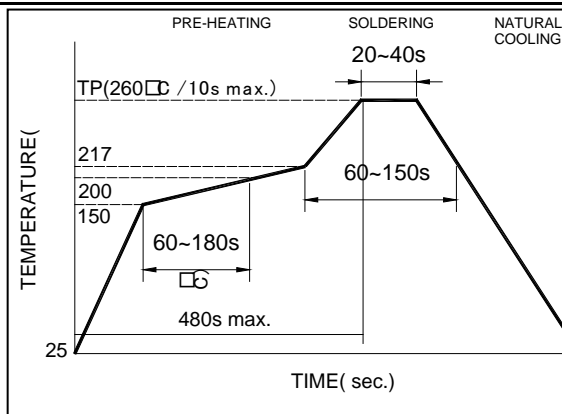

**Note:**  
 ·Preheat circuit and products to 150°C  
 ·260°C tip temperature (max)  
 ·Reflow times: no more than 2 times  
 ·Solder paste thickness: the best 0.08mm is ,but max is 0.1mm

**Figure 2.  
Hand Soldering**

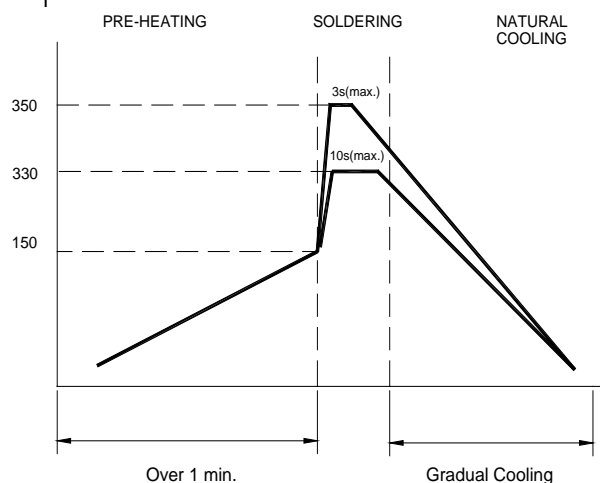

**Note:**  
 Use a 20 watt soldering iron with tip diameter of 1.0mm  
 ·Limit soldering time to 3 sec.

**6.MATERIAL LIST**

NO	DESCRIPTION	DESCRIPTION	SUPPLIER
1	Upper Plate	Ferrite	Flag Magnetic Or equivalent
2	Core	Ferrite Core	Flag Magnetic Or equivalent
3	Wire	Enameled Copper Wire	Elektrisola Or equivalent

REMARK:

APPROVED BY	CHECKED BY	DRAWN BY
肖中华	黄志伟	谭晶晶



惠州市德立电子有限公司  
HUI ZHOU DE LI ELECTRONICS CO., LTD

CUSTOMER:	2144	REV NO:	A
DESCRIPTION:	COMMON MODE CHOKE	PAGE NO:	PAGE 5 OF 6
PART NO:	WBA0603D900PT-F-HF	SN.	
CUSTOMER NO:		DATE:	2023年7月6日

7. PACKAGING(unit: mm)

Type	0603
Quantity	3000

TAPING DRAWINGS

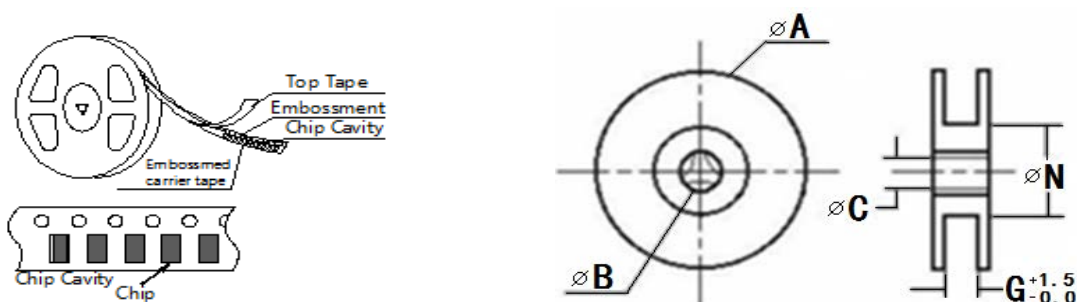

REEL DIMENSIONS(UNIT:mm)

	A	B	C	N	G
CF-8	178±2.0	22±2.0	12.5±1.5	57±2.0	8

LEADER AND BLANK PORTION

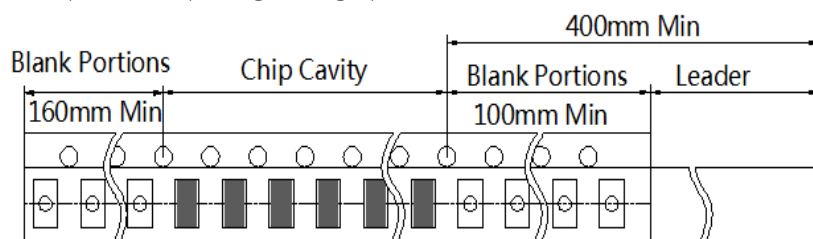

PEELLING OFF FORCE:0.05 to 0.7N in the direction show below.

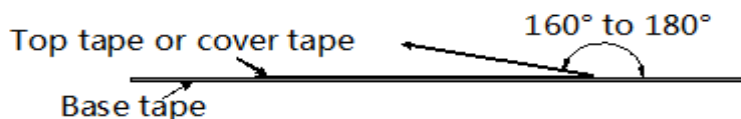

注意:

此物料不涉及汽车或相关产品方面的应用，否则，由此引起的一切品质和责任问题，我司将概不承担。

APPROVED BY	CHECKED BY	DRAFT
肖中华	黄志伟	谭晶晶



惠州市德立电子有限公司  
HUI ZHOU DE LI ELECTRONICS CO., LTD

CUSTOMER:	2144	REV NO:	A
DESCRIPTION:	COMMON MODE CHOKE	PAGE NO:	PAGE 6 OF 6
PART NO:	WBA0603D900PT-F-HF	SN.	
CUSTOMER NO:		DATE:	2023年7月6日

**8.ELECTRICAL CHARACTERISTIC CURVE**

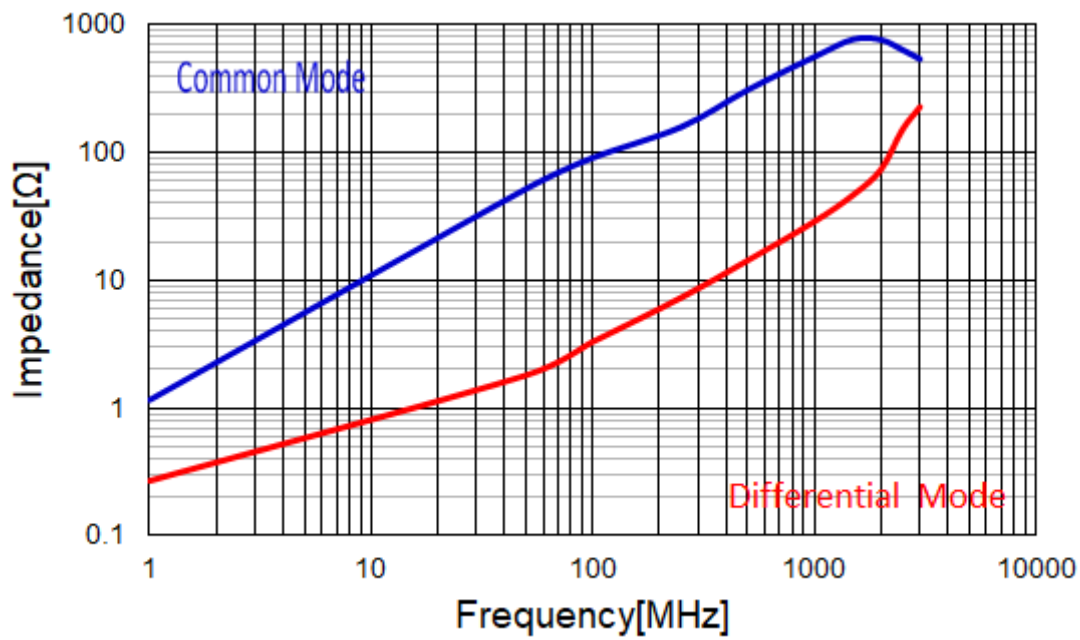

APPROVED BY	CHECKED BY	DRAFT
肖中华	黄志伟	谭晶晶

## X-ON Electronics

Largest Supplier of Electrical and Electronic Components

*Click to view similar products for [Common Mode Chokes / Filters](#) category:*

*Click to view products by [DDY](#) manufacturer:*

Other Similar products are found below :

[PE-64683](#) [RD5122-6-9M6](#) [RD6137-6-7M5](#) [RD8147-16-3M0](#) [ST6118T-R](#) [FE3X025-10-7NL](#) [RD7147-25-0M7](#) [TCM0806G-350-2P-T](#)  
[TCM0806G-650-2P-T](#) [IND-0110](#) [UAL21VR0802000](#) [UALSC023000000](#) [UALSC1020JH000](#) [UALSU10VD20010](#) [UALSU9VD070100](#) [36-00037](#) [UALW21HS072450](#) [UALSU9H0208000](#) [UAL24VK06450CH](#) [PLT10HH501100PNB](#) [PLT10HH401100PNB](#) [PLT10HH1026R0PNB](#)  
[36-00029-01](#) [PE-67531](#) [TLH10UB](#) [113 0R5](#) [2752045447](#) [7351V](#) [CMF16-153131](#) [RD7147-6-6M0](#) [T8116NLT](#) [FE2X10-4-2NL](#) [36-00029-07](#)  
[T8003NLT](#) [CTX01-13663](#) [CTX66-19521-R](#) [RC212-0.5-10M](#) [RC112-0.4-15M](#) [RC212-0.6-6M8](#) [RC212-0.4-15M](#) [RC112-0.3-30M](#)  
[WTCF2012Z0M751PB](#) [PH9408.814NLT](#) [PAC6006.364NLT](#) [PAC6006.444NLT](#) [PAC6006.204NLT](#) [PH9407.204NLT](#) [PAC6006.264NLT](#)  
[PH9408.105NLT](#) [PH9408.494NLT](#) [PAC6006.104NLT](#)