

SYMBOL DEFINITION		TOTAL NO OF INSPECTIONS REQUIRED	MISSING SYMBOLS
A DIMENSION WITHOUT AN INSPECTION REPORT SYMBOL DOES NOT REQUIRE INSPECTION. IT MAY BE CONTROLLED ON THE INDIVIDUAL COMPONENT DRAWING.		27	NO MISSING SYMBOL NUMBER
		LAST NO. USED	21

DWO STATUS				ZONE				REVISION HISTORY				AUTH	DR	APVD	APVD		
DATE	STG	REV	N/P	CHO													
19N003	R	03	-	-	-	-	-	-	-	ALL ACTIVE PARTS - CLEARED REV COLUMN: REDRAWN TO PD AND UPDATED PDM ATTRIBUTES				247796	JTV	FKV	RMD
21N005	R	04	-	-	-	-	-	-	-	02977112, 02962718, 02965400, 02962543, 12010566, 12010769, 12015010 & 12052489- ADDED WING CONSTRUCTION III VIEW				274984	CJP	CJP	EST
08DE05	R	05	-	-	-	-	-	-	-	02977112, 02962718, 02965400, 02962543, 12010566, 12010769, 12015010 & 12052489- UPDATED WING CONSTRUCTION III				275486	CJP	CJP	EST

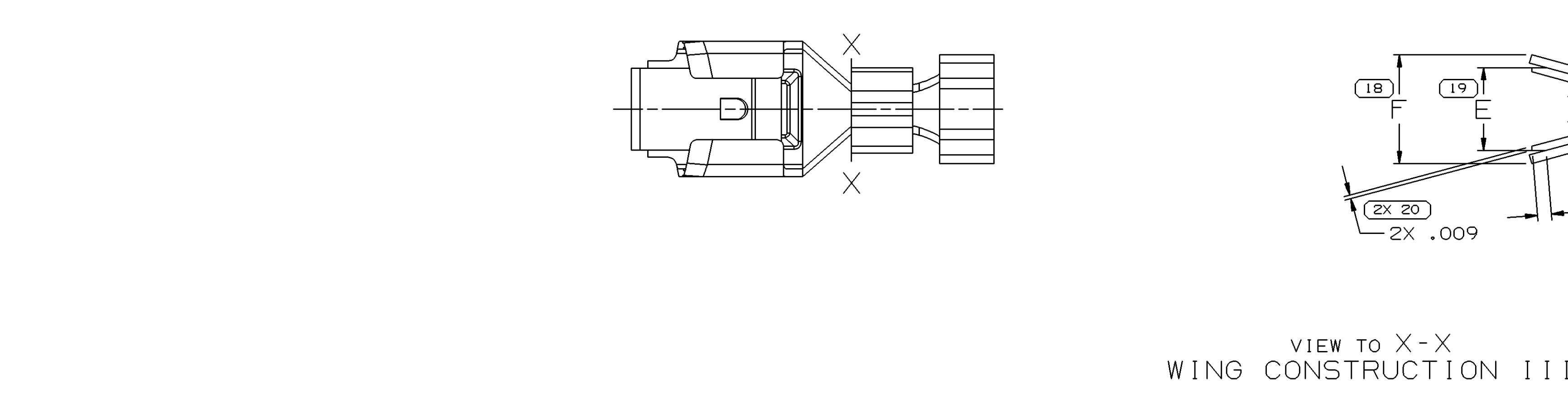
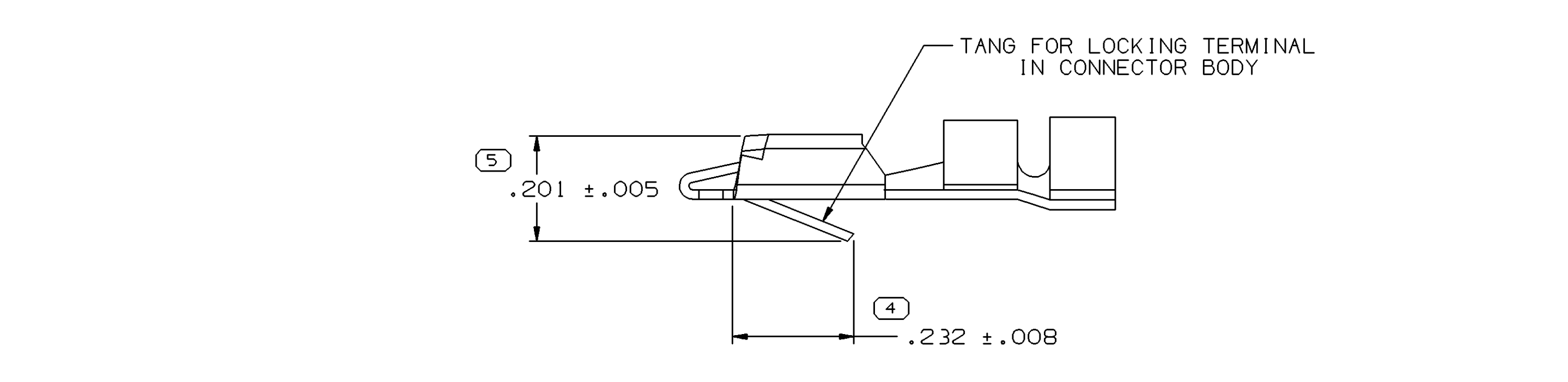
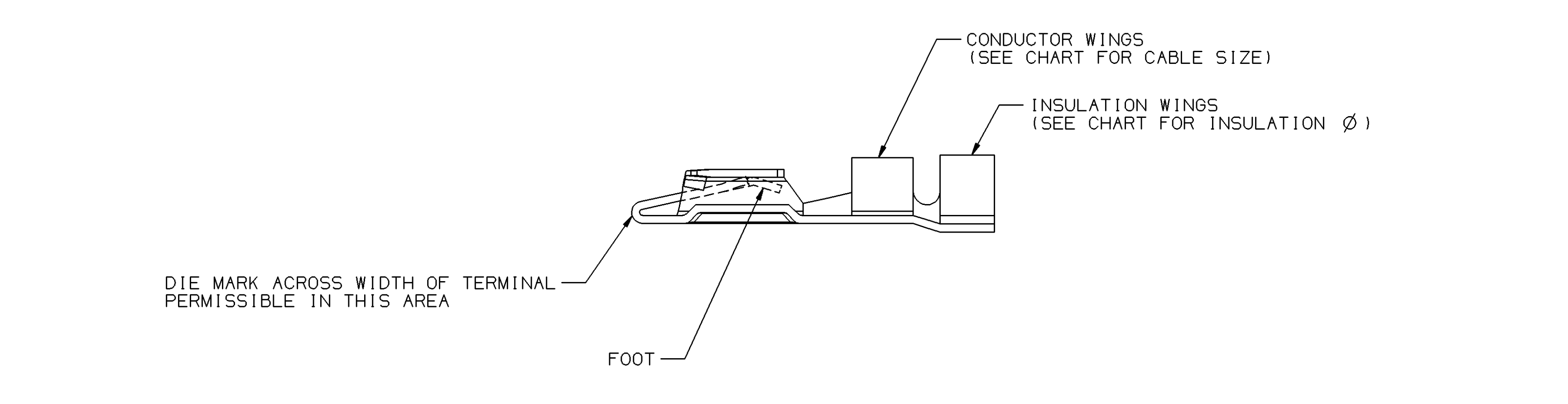
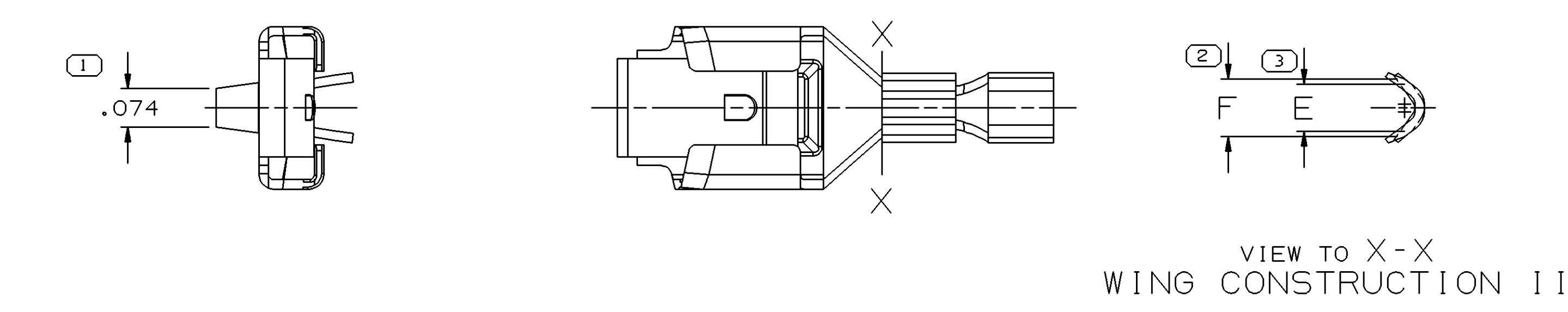
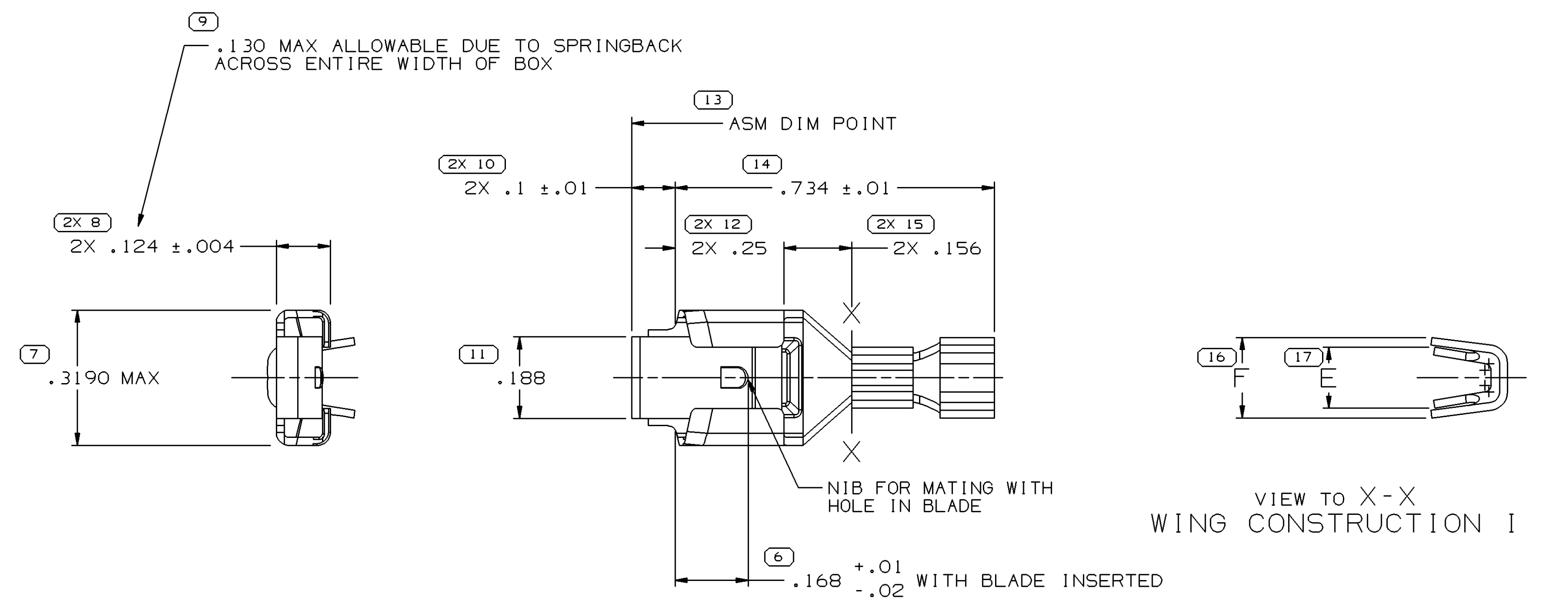

- NOTES
- UNLESS OTHERWISE SPECIFIED AND/OR INDICATED: DIMENSIONS ARE TO FACE OF VIEW SHOWN AND AUTOMATICALLY ROUNDED BY COMPUTER FOR INSPECTION (SEE MATH MODEL FOR PRECISE DIMENSIONS). FOR ALL OTHER DIMENSIONS NOT SHOWN BUT REQUIRED FOR TOOL BUILD, SEE MATH MODEL FOR PRECISE TOOL PATH DATA.
 - "PXX" INDICATES "P" PLUS LAST TWO DIGITS OF MAKE DIE SERIES NUMBER (P01, P02, P03, ETC.).
 - TO FIT .032 X .250 BLADE

PART NO	REV	N/P	STATUS	MAT'L SIZE	MAT'L SPEC	PART NO	REV	N/P	STATUS	MAT'L SPEC	PART NO	REV	N/P	STATUS	MAT'L SPEC	NIB	TANG	FOOT	SIZE (MM)	DIA (MM)	ID	TYPE	WING CONST	E _{10.015}	F _{10.015}
				0.180 X 1.188		12052489	A3	-	OBSOLETE	M1588AAE						X	X	X	0.8 - 0.5	2.40 - 2.03	19	102	III	.140	.165
				0.180 X 1.188		12040503	A	-	OBSOLETE	M157305B						X	X	X	0.8 - 0.5	3.13 - 2.03	19	104	III	.125	.195
				0.180 X 1.188		12015010	B4	-	OBSOLETE	M1588AAE						X	X	X	(2) 0.8 - 0.5	2.40 - 2.03	(2) 19	106	III	.190	.250
				0.180 X 1.188		12010771	B	01		M1588AAE						X	X	X	0.35 - 0.22	2.08 - 1.12	23	102	I	.090	.145
				0.180 X 1.188		12010770	B	01		M1588AAE						X	X	X	0.35 - 0.22	2.08 - 1.12	23	102	I	.090	.145
				0.180 X 1.188		12010769	C3	-		M157305B						X	X	X	(2) 0.35 - 0.22	2.08 - 1.12	(2) 23	101	III	.150	.215
				0.180 X 1.188		12010566	C3	-		M1588AAE						X	X	X	0.8 - 0.5	2.40 - 2.03	19	102	III	.140	.165
				0.180 X 1.188		08900236	A	-	OBSOLETE	M157305B						X	X	X	0.22	1.19 - 1.02	24	101	I	.100/.080	.120/.100
12033824	E	01		0.180 X 1.188	M140305B										X	X	X	2.0 - 1.0	3.05 - 2.48	15	103	I	.145	.235	
02984712	CB	01		0.018 X 1.188	M140305B										X	X	X	2.0 - 1.0	3.05 - 2.48	15	101	I	.140	.185	
02984592	CC	-	OBSOLETE	0.018 X 1.188	M140305B										X	X	X	2.0 - 1.0	3.97 - 3.36	15	101	I	.140	.230	
02984313	CB	-	OBSOLETE	0.018 X 1.188	M140305B										X	X	X	2.0 - 1.0	3.97 - 3.36	15	101	I	.140	.230	
02984103	CD	-	OBSOLETE	0.018 X 1.188	M140305B	08917170	CD	-	OBSOLETE	M157305B						X	X	X	(2) 0.8 - 0.5	2.40 - 2.03	(2) 19	101	I	.190	.250
02977938	CC	01		0.018 X 1.188	M140305B										X	X	X	0.8 - 0.5	3.13 - 2.69	19	101	I	.135	.185	
02977521	CC	-	OBSOLETE	0.018 X 1.188	M140305B						02977963	CC	-	OBSOLETE	V140305B				(2) 0.8 - 0.5	2.40 - 2.03	(2) 19	101	I	.190	.250
02977520	CB	-	OBSOLETE	0.018 X 1.188	M140305B										X	X	X	0.8 - 0.5	2.40 - 2.03	19	101	I	.135	.175	
02977369	CB	02		0.018 X 1.188	M140305B	02977705	CB	02		M157305B					X	X	X	2.0 - 1.0	3.97 - 3.36	15	101	I	.140	.230	
02977106	CB	01		0.018 X 1.188	M140305B	02977375	CB	01		M157305B					X	X	X	0.8 - 0.5	3.13 - 2.69	19	101	I	.135	.185	
02973369	CC	01		0.018 X 1.188	M140305B	02977114	CC	01		M157305B					X	X	X	0.8 - 0.5	3.13 - 2.69	19	101	I	.135	.185	
02965199	CC	02		0.018 X 1.188	M140305B	02965511	CC	01		M157305B	02977578	CC	-	OBSOLETE	V140305B				2.0 - 1.0	3.97 - 3.36	15	101	I	.140	.230
02965156	CC	-	OBSOLETE	0.018 X 1.188	M140305B	02965401	CC	02		M157305B					X	X	X	0.8 - 0.5	2.40 - 2.03	19	101	I	.135	.175	
02962952	CC	-	OBSOLETE	0.018 X 1.188	M140305B	02965728	CC	02		M157305B	02977936	CC	-	OBSOLETE	V140305B				2.0 - 1.0	3.05 - 2.48	15	101	I	.140	.185
02962718	CD3	-		0.018 X 1.188	M140305B	02977112	CD3	-		M157305B					X	X	X	(2) 0.8 - 0.5	2.40 - 2.03	(2) 19	101	III	.190	.250	
02962573	CB	-	OBSOLETE	0.018 X 1.188	M140305B	02965867	CB	02		M157305B	02973224	CB	-	OBSOLETE	V140305B				2.0 - 1.0	3.05 - 2.48	15	101	I	.140	.185
02962572	CB	01		0.018 X 1.188	M140305B	02965510	CB	02		M157305B					X	X	X	0.8 - 0.5	2.40 - 2.03	19	101	I	.135	.175	
02962543	CE3	-		0.018 X 1.188	M140305B	02965400	CE4	-		M157305B	02965404	CD	-	OBSOLETE	V140305B				(2) 0.8 - 0.5	2.40 - 2.03	(2) 19	105	III	.190	.250
02962508	CC	01		0.018 X 1.188	M140305B	02965141	CC	02		M157305B	02965345	CC	-	OBSOLETE	V140305B				0.8 - 0.5	2.40 - 2.03	19	101	I	.135	.175
02962447	CC	01		0.018 X 1.188	M140305B	02965142	CC	02		M157305B	02965399	CC	-	OBSOLETE	V140305B				2.0 - 1.0	3.05 - 2.48	15	101	I	.140	.185

DIMENSIONAL RANGE (IN)		CHART	THIRD ANGLE PROJECTION	DO NOT SCALE
FROM	TO			
0	500	2		
500	>500	1		
TOLERANCE UNLESS OTHERWISE SPECIFIED				
±.005				
±.010				
ANGULAR TOLERANCE 12°				

DELPHI
DELPHI PACKARD ELECTRIC SYSTEMS
WARREN, OH

DR	DATE
APVD1 J. LUIS TAPIA	19N003
APVD2 FRANCISCO KOPCA	19N003
APVD3 RICHARD DICINTIO	19N003
APVD4	

UNLESS OTHERWISE SPECIFIED
THIS DOCUMENT IS IN ACCORDANCE WITH ASME Y14.5M-1994
AS AMENDED BY THE 2003 ADDENDUM. DIMENSIONS AND
TOLERANCES UNLESS OTHERWISE SPECIFIED
FEATURES MAY BE OMMITTED SEPARATELY KNOWLEDGE OF DATUM

ALL DIMENSIONS ARE IN INCHES

REFERENCE

DRAWING NAME: TAXI TERM F 56

DRAWING NUMBER: 02962874

SIZE: A0 SCALE: 5:1 FRAME NO: 1 OF 1 SHEET NO: 13 REV: 05

X-ON Electronics

Largest Supplier of Electrical and Electronic Components

Click to view similar products for [Automotive Connectors](#) category:

Click to view products by [Delphi](#) manufacturer:

Other Similar products are found below :

[003-018-000](#) [600858](#) [60403001](#) [60993906-B](#) [60993913-B](#) [629515004020001](#) [M902-2131](#) [M902-2161](#) [M902-2344](#) [72.330.1035.1](#)
[73.353.4028.0](#) [F118010](#) [F119300-B](#) [F132210](#) [F132210-B](#) [F166900](#) [F180100](#) [F258300](#) [F258300-B](#) [F294300-B](#) [F339100](#) [F339700](#) [F358300-](#)
[B](#) [F374110](#) [F407400](#) [F412210](#) [F427600](#) [F444110](#) [F487000](#) [F495100-B](#) [F500900-B](#) [F509500B-B](#) [770444-1](#) [776880-1](#) [827153-1](#) [881735-1](#)
[8N1515-32-24P](#) [9-1326727-8](#) [9-1326729-8](#) [925467-1](#) [925474-1](#) [928905-1](#) [936398-2](#) [964562-1](#) [964562-4](#) [964731-2](#) [965051-1](#) [968782-1](#)
[GT17SA-8DS-HU](#) [GT17VS-10DP-5.2CF](#)