

SYMBOL DEFINITION		TOTAL NO OF INSPECTIONS REQUIRED	24
A	DIMENSION WITHOUT AN INSPECTION REPORT SYMBOL DOES NOT REQUIRE INSPECTION. IT MAY BE CONTROLLED ON THE INDIVIDUAL COMPONENT DRAWING.	LAST NO. USED	17

DWG STATUS				ZONE	REVISION HISTORY		AUTH	DR	APVD	APVD
DATE	STG	REV	N/P	CHG						
17MY11	R	01	-	-	RELEASED		414232	AGM	JVM	RJB
28JN11	R	02	-	-	13849932 - 1.6 WAS 1.7; 13849935 - 1.5-2.5 WAS 1.25-2.5 AND 2.2-3 WAS 2.05-3 AND 13849936 - REVISED GRAPHICS		414629	JRL	JRL	RBS
18AU11	R	03	-	-	ALL PARTS - UPDATED PDM ATTRIBUTES		415160	DMC	DMC	RBS
01SE11	R	04	-	-	ALL PARTS - UPDATED PDM ATTRIBUTES, NOTE B ADDED		415238	MK	MK	RBS
060C11	R	05	-	-	ALL PARTS: MOVED DIM 1 TO SECTION K-K, DIM 3 WAS 4.05 +/-0.05, DIM 7 WAS 2X 3.75 +/-0.06		415703	MK	MK	RBS
240C11	R	06	-	-	ALL PARTS: UPDATED PDM ATTRIBUTES		415823	MK	MK	RBS
15AP13	R	07	-	-	ALL PARTS: REVISED LEAD-IN COIN AND NOTES		422093	MM	MM	RJB
28MY13	R	08	-	-	ALL PARTS: ADDED NOTE TO TOD		422733	MM	MM	RJB
06AU13	R	09	-	-	15500441: ADDED PART; ALL PARTS: REVISED NOTE 4.		423450	MM	MM	RJB
22AP14	R	10	-	-	15500441 - UPDATED PART AVAILABILITY		426302	APB	APB	RJB
28JL14	R	11	-	-	ALL PARTS - UPDATED PDM ATTRIBUTES		427120	JVR	JVM	LES
200C14	R	12	-	-	13849936 & 13849932 - UPDATED CABLE DIAMETER COLUMN		427961	ABH	JVM	LES

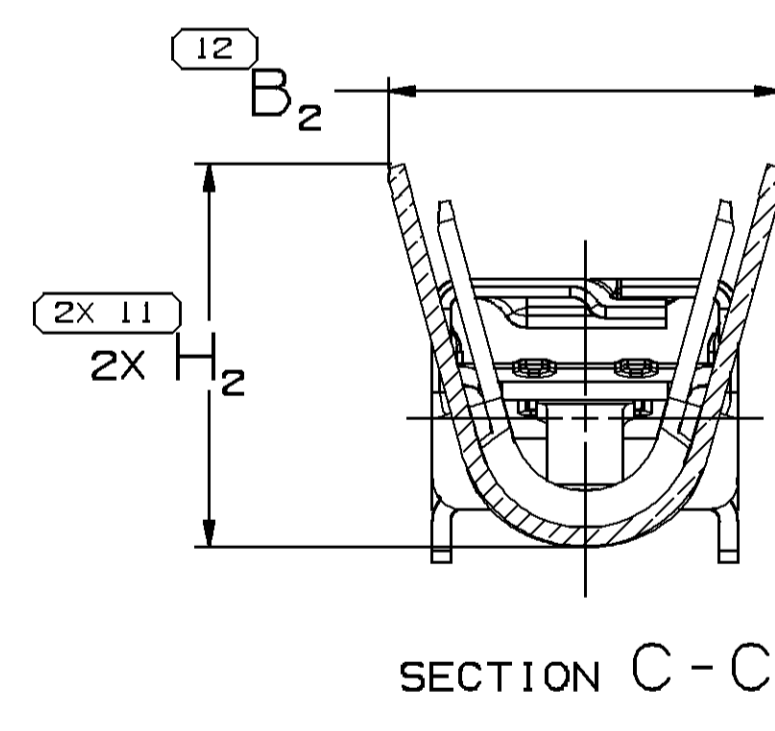

- NOTES
- UNLESS OTHERWISE SPECIFIED AND/OR INDICATED:
 - DIMENSIONS ARE TO FACE OF VIEW SHOWN AND AUTOMATICALLY ROUNDED BY COMPUTER FOR INSPECTION (SEE MATH MODEL FOR PRECISE DIMENSIONS). FOR ALL OTHER DIMENSIONS NOT SHOWN BUT REQUIRED FOR TOOL BUILD, SEE MATH MODEL FOR PRECISE TOOL PATH DATA.
 - RECOMMENDED MATING BLADE THICKNESS 0.8 +0.04/-0.03mm RECOMMENDED MATING BLADE WIDTH NOT TO EXCEED 2.9mm AND NO LESS THAN 2.4mm. SEE USCAR EWCAP-001 DRAWING (2.8 BLADE) FOR OTHER MATING BLADE REQUIREMENTS.
 - DO NOT PROBE, TEST OR OTHERWISE CONTACT THE INTERIOR REGION (THE SPRING OR ANY MOVING PART) OF THIS TERMINAL. SEVERE DAMAGE CAN OCCUR, COMPROMISING THE PERFORMANCE OF THE ELECTRICAL INTERFACE.
 - MAXIMUM CURRENT CAPACITY AS DEFINED BY USCAR-2 R5 SECTION 5.3.3 IS 35 AMPS WITH 5.0 mm² COPPER CABLE.
 - * DENOTES DIMENSIONS MADE AT CUT-OFF AND CRIMP DIE
 - PLUS ANGLE IS WING BOTTOM SURFACE ROTATED COUNTERCLOCKWISE AGAINST THE BOX BOTTOM SURFACE.
 - PLATING TYPE:
 - REFLOW TIN 1.9 - 3.3 MICROMETERS THICK OVER NICKEL UNDERPLATE 0.13 - 0.5 MICROMETERS THICK.
 - PARTS MEET THE PERFORMANCE REQUIREMENTS OF GMW3191 DEC 2007 AND SAE/USCAR-2 R5 REVISIONS FOR THE FOLLOWING CLASSIFICATIONS:
 - TEMPERATURE CLASS 3 (-40°C TO +125°C)
 - VIBRATION CLASS 1 (ON BODY OR CHASSIS)
 - SEALING CLASS 1 (UNSEALED).

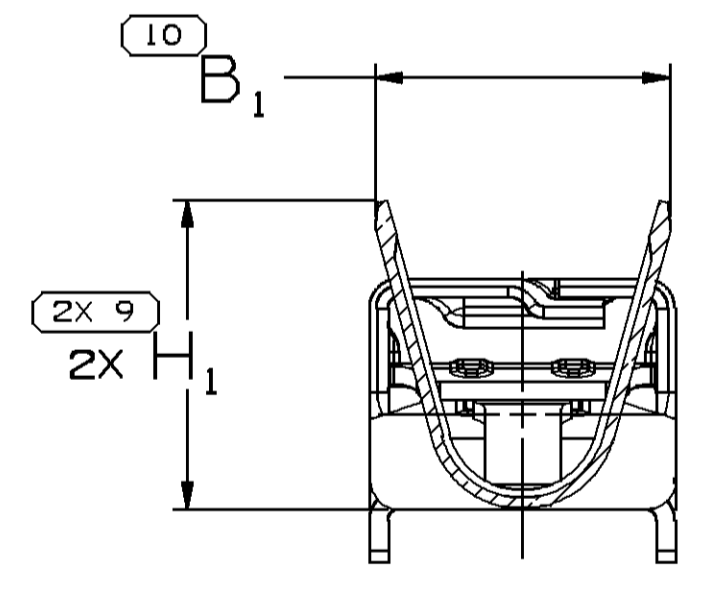
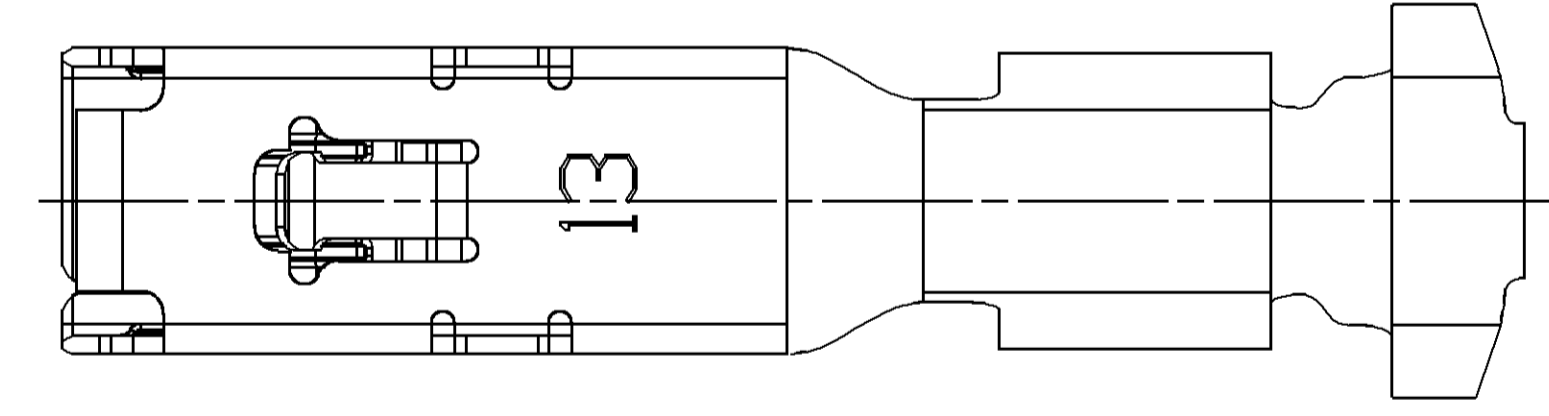
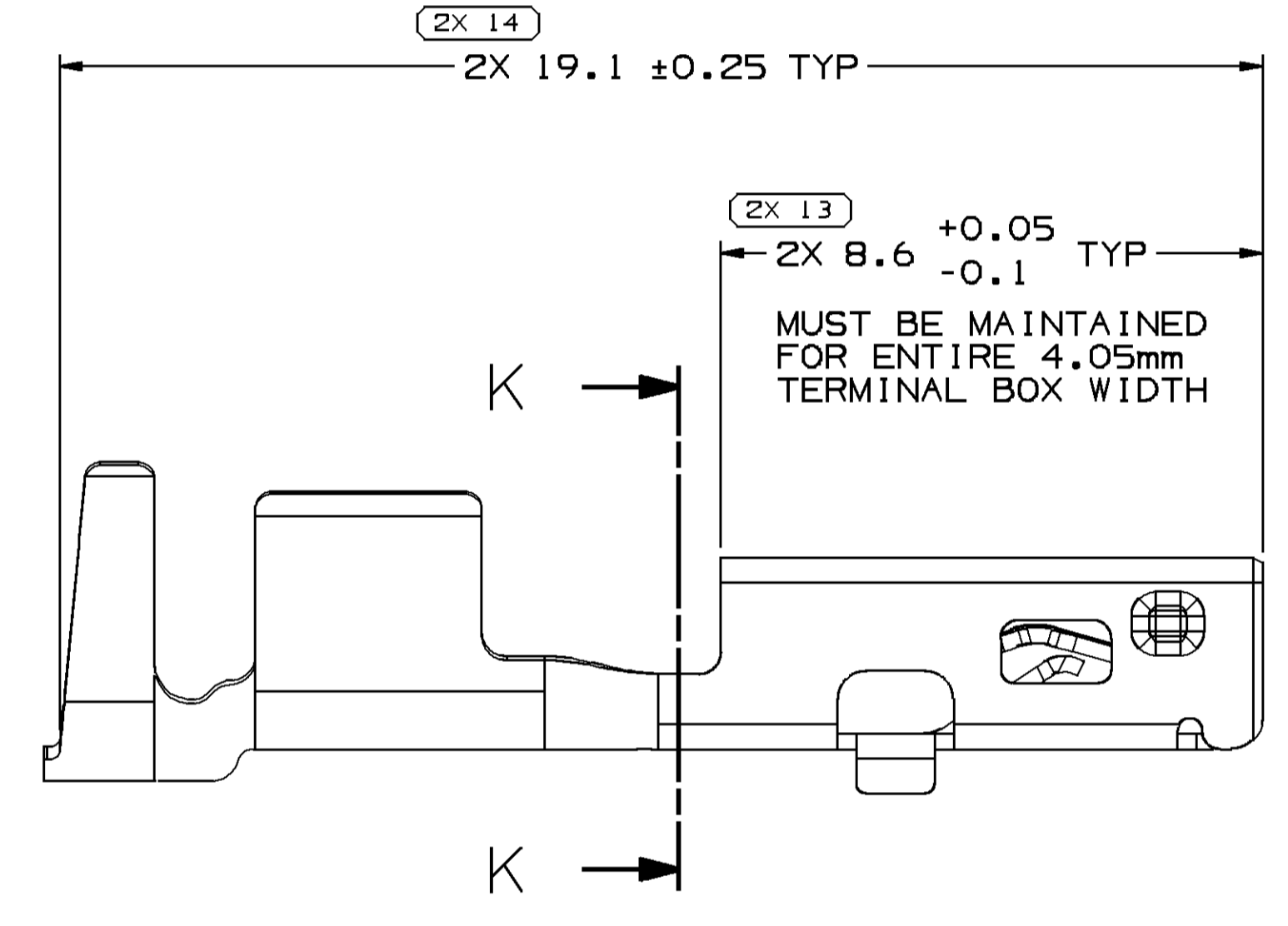
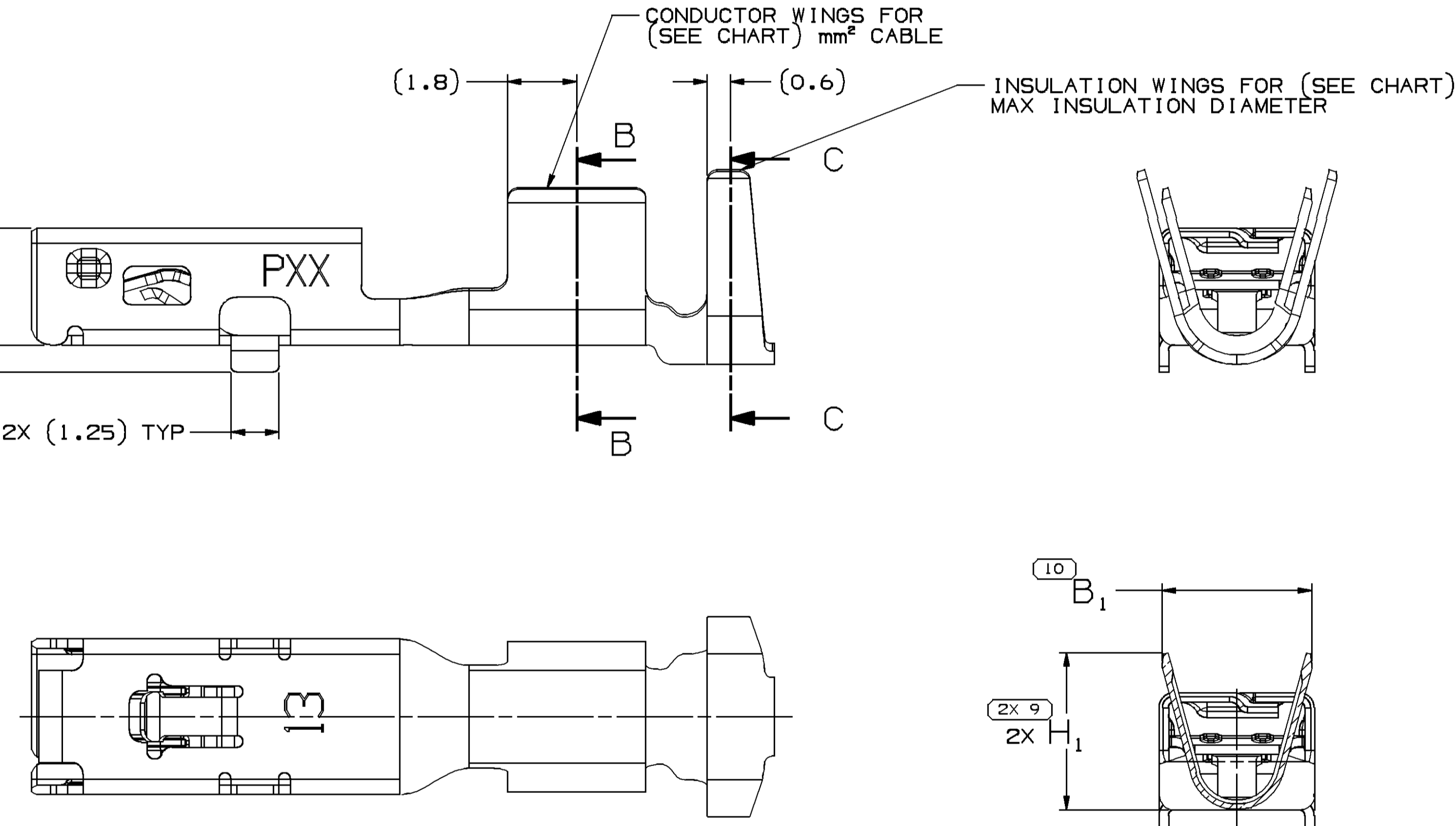
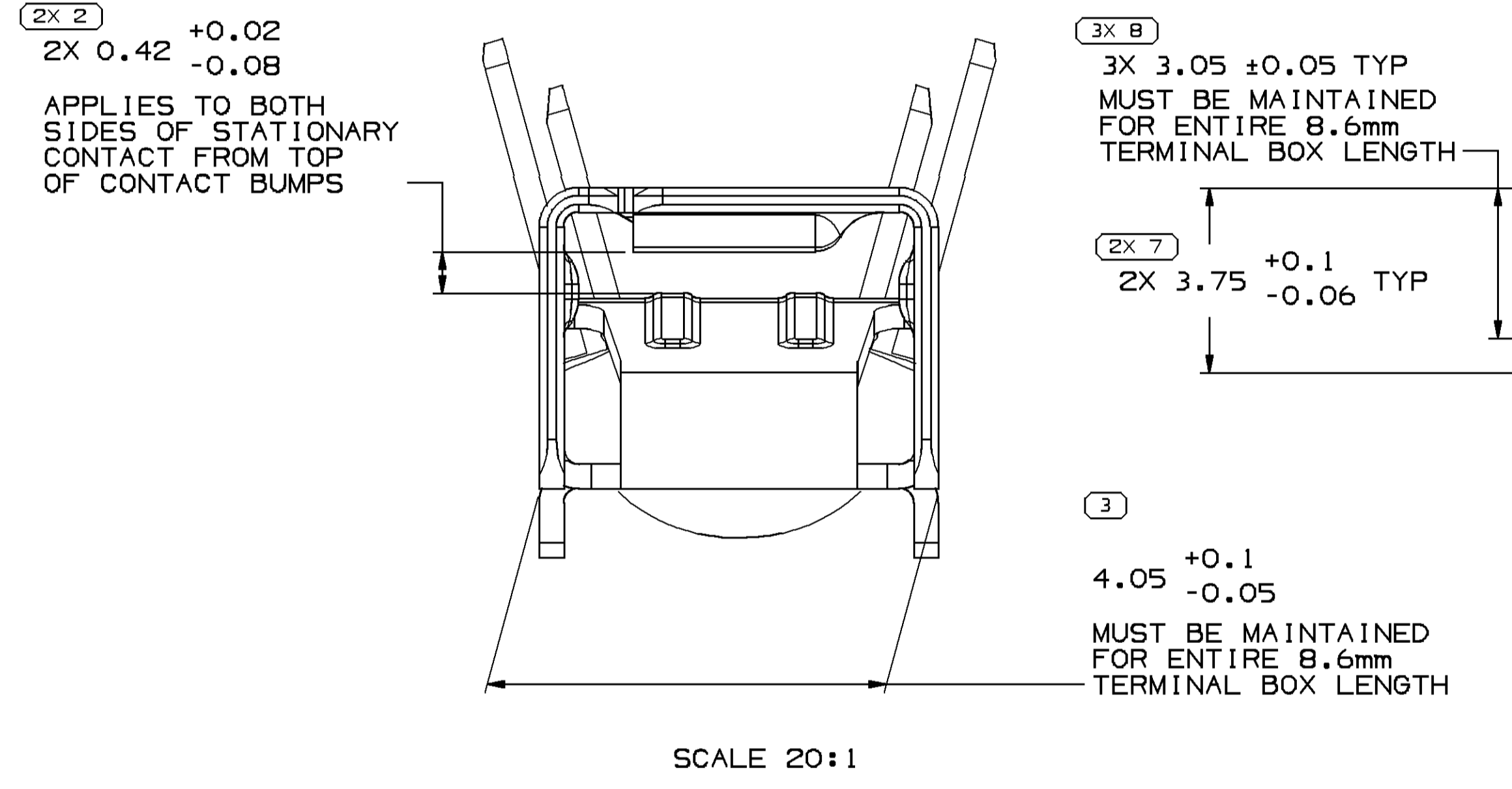
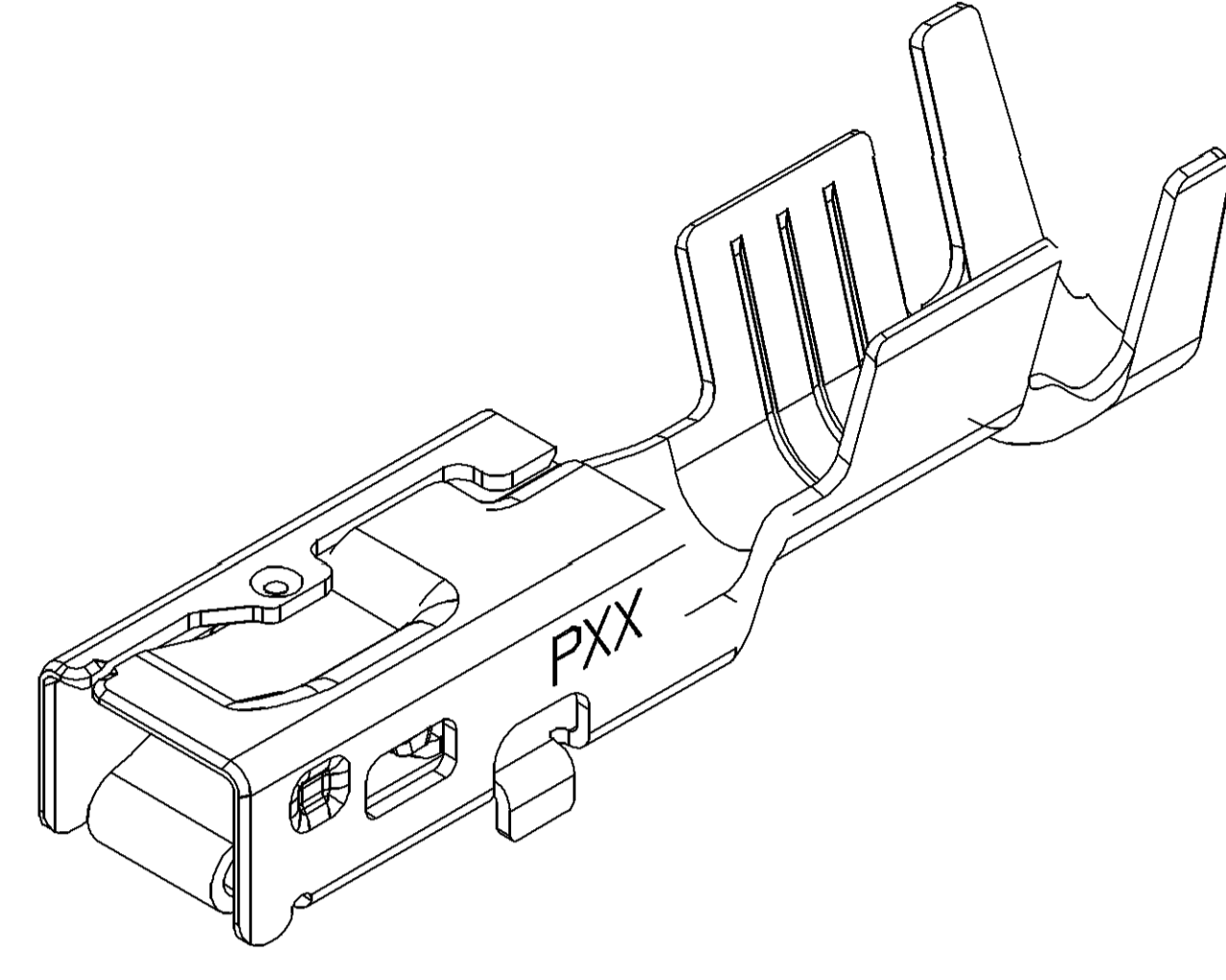
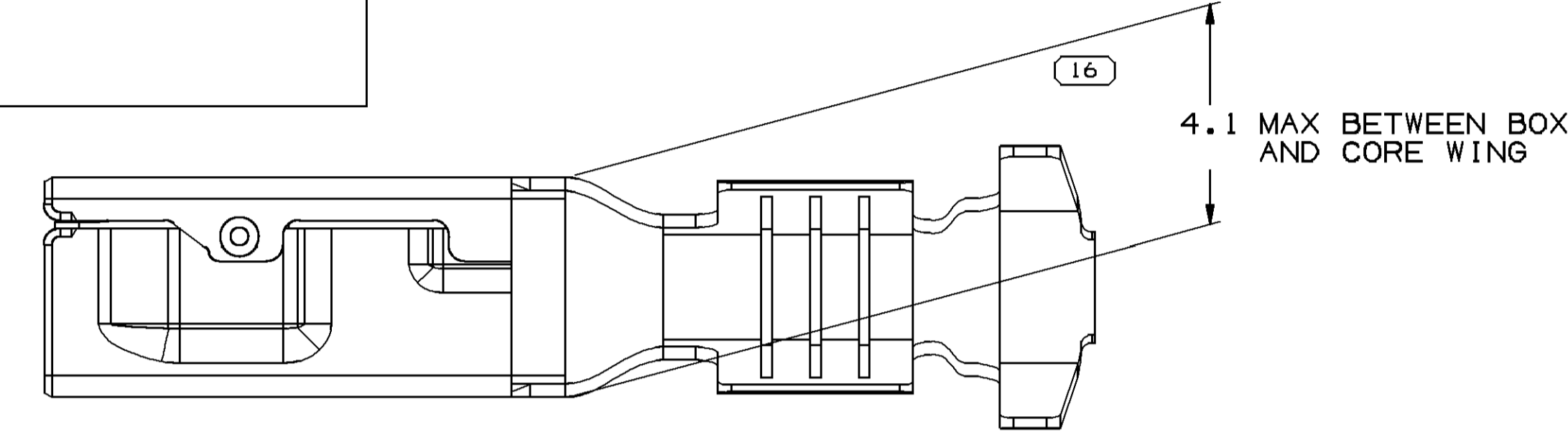
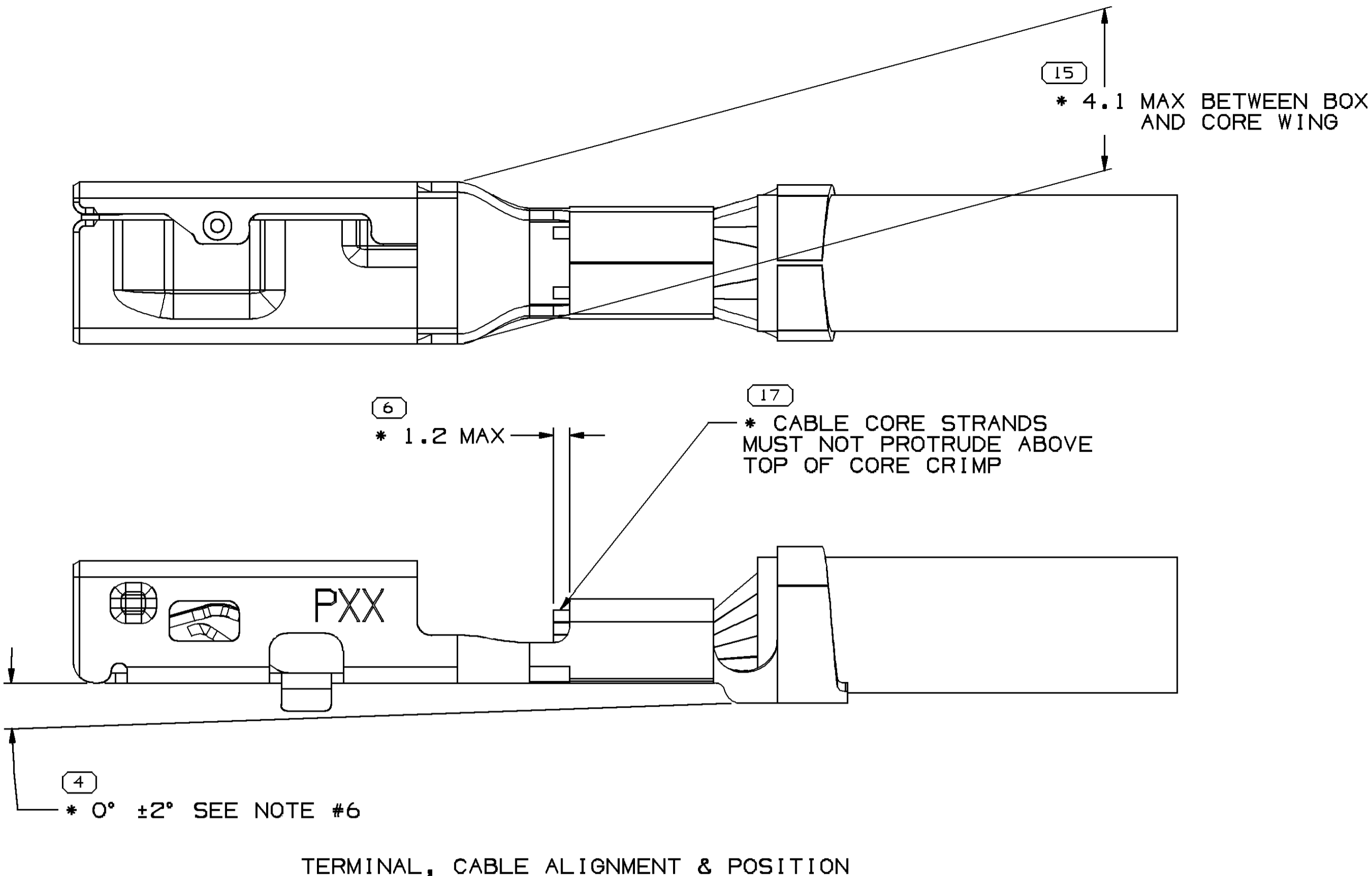
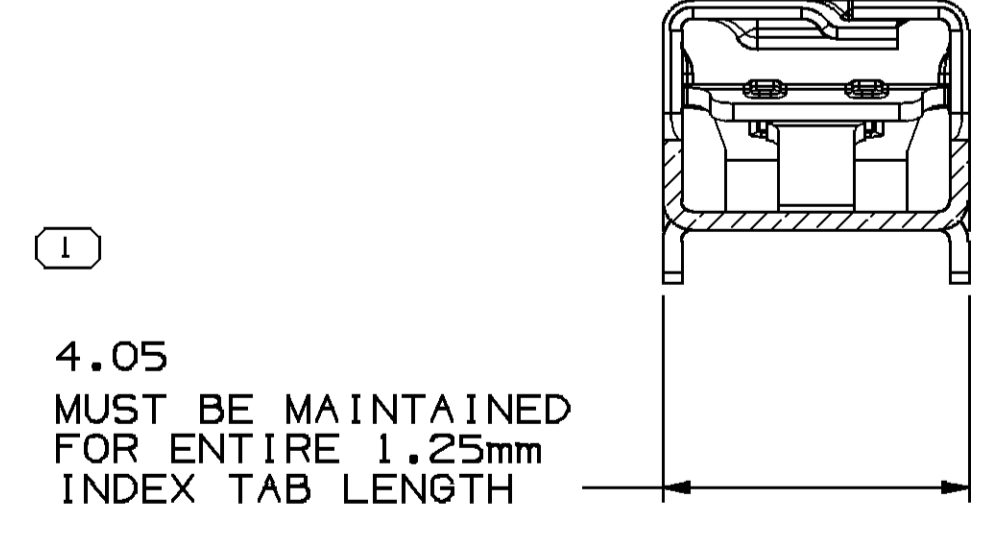

PART NUMBER	REV	N/P	MATERIAL DESCRIPTION	MATERIAL THICKNESS	CONTACT AREA PLATING TYPE (SEE NOTE 7)	CRIMP AREA PLATING TYPE (SEE NOTE 7)	I.D.	CABLE SIZE (mm²)	CABLE DIAMETER	B ₁ ±0.15	B ₂ ±0.25	(H ₁)	(H ₂)
15500441	01	AC	TIN PLATED HIGH PERF COPPER ALLOY	0.25	I	I	10	4 - 5	3.2 - 4.2	5.1	6	5	5.5
13849932	04	AC	TIN PLATED HIGH PERF COPPER ALLOY	0.25	I	I	25	0.13 - 0.22	0.81 - 1.1	1.6	2	1.6	1.9
13849933	03	AC	TIN PLATED HIGH PERF COPPER ALLOY	0.25	I	I	21	0.3 - 0.6	1.2 - 1.9	2.15	2.8	2.25	3
13849934	03	AC	TIN PLATED HIGH PERF COPPER ALLOY	0.25	I	I	17	0.75 - 1	1.7 - 2.25	2.7	3.4	2.7	3.5
13849935	03	AC	TIN PLATED HIGH PERF COPPER ALLOY	0.25	I	I	14	1.5 - 2.5	2.2 - 3	3.55	4.4	3.7	4.55
13849936	03	AC	TIN PLATED HIGH PERF COPPER ALLOY	0.25	I	I	13	2 - 3	2.3 - 3.4	3.9	5.2	4.1	5.05

DIMENSIONAL RANGE (MM)		CHART CD	THIRD ANGLE PROJECTION	DO NOT SCALE
FROM	TO			
0	> 12			
10	12			
10.1	10.2			
10.1	10.2			
ANGULAR TOLERANCE ±2°				

DELPHI
DELPHI PACKARD ELECTRICAL/ELECTRONIC ARCHITECTURE

WARREN, OH
COPYRIGHT 2011 DELPHI CORPORATION AND/OR ITS AFFILIATES. ALL RIGHTS RESERVED.
THIS DRAWING IS THE PROPERTY OF DELPHI CORPORATION AND CONTAINS DELPHI CONFIDENTIAL INFORMATION. THE REPRODUCTION, DISTRIBUTION AND UTILIZATION OF THIS DOCUMENT OR ITS CONTENTS OR DATA, AS WELL AS COMMUNICATION OF ANY CONTENT TO OTHERS, WITHOUT EXPRESS AUTHORIZATION, IS PROHIBITED.

DWG TYPE: PART DRAWING

UNLESS OTHERWISE SPECIFIED THIS DOCUMENT IS IN ACCORDANCE WITH ASME Y14.5M-1994 AS MODIFIED BY THE 3D MODEL DIMENSIONING AND TOLERANCING ADDENDUM-2001. SEPARATE PATTERNS OF FEATURES MAY BE DIMED SEPARATELY, REGARDLESS OF DATUM REFERENCES.

ALL DIMENSIONS ARE IN MILLIMETERS

REFERENCE:

DRAWING NAME: TAXI TERM F OCS 2.8 SN

DRAWING NUMBER: 13819334

SIZE: A0 SCALE: 10:1 FRAME NO: 1 OF 1 SHEET NO: 1 OF 1 STG: REV: N/P: R 12

X-ON Electronics

Largest Supplier of Electrical and Electronic Components

Click to view similar products for [Automotive Connectors](#) category:

Click to view products by [Delphi](#) manufacturer:

Other Similar products are found below :

[003-018-000](#) [600858](#) [60403001](#) [60993906-B](#) [60993913-B](#) [629515004020001](#) [M902-2131](#) [M902-2161](#) [M902-2344](#) [72.330.1035.1](#)
[73.353.4028.0](#) [F118010](#) [F119300-B](#) [F132210](#) [F132210-B](#) [F166900](#) [F180100](#) [F258300](#) [F258300-B](#) [F294300-B](#) [F339100](#) [F339700](#) [F358300-](#)
[B](#) [F374110](#) [F407400](#) [F412210](#) [F427600](#) [F444110](#) [F487000](#) [F495100-B](#) [F500900-B](#) [F509500B-B](#) [770444-1](#) [776880-1](#) [827153-1](#) [881735-1](#)
[8N1515-32-24P](#) [9-1326727-8](#) [9-1326729-8](#) [925467-1](#) [925474-1](#) [928905-1](#) [936398-2](#) [964562-1](#) [964562-4](#) [964731-2](#) [965051-1](#) [968782-1](#)
[GT17SA-8DS-HU](#) [GT17VS-10DP-5.2CF](#)