

CliQ II DIN Rail Power Supply

24V 480W 3 Phase / DRP024V480W3B□



Highlights & Features

- Universal AC input voltage: 3 x 320Vac – 600Vac (3-Phase) or 2 x 360Vac – 600Vac (2-Phase)
- Power will not de-rate for the entire input voltage range
- Power Boost of 150% for 5 seconds and 200% for 2 seconds
- Full corrosion resistant aluminium chassis
- Conformal coating on PCBA to protect against chemical and dust pollutants
- Hazardous Locations approval to ATEX and Class I, Div 2 (DRP024V480W3BA)

Safety Standards



CB Certified for worldwide use

Model Number: DRP024V480W3B□
Unit Weight: 1.35 kg (2.98 lb)
Dimensions (L x W x D): 121 x 140 x 117.3 mm (4.76 x 5.51 x 4.62 inch)

General Description

The CliQ II 3-phase DIN rail power supply series offers output voltage of 24V. These products are encased in rugged yet lightweight full aluminium body that can withstand shock and vibration according to IEC 60068-2 standard. The series of 3-phase products can operate over a wide temperature range of -25°C to +80°C. These products also feature universal AC input voltage range for 3-phase from 320Vac to 600Vac or 2-phase from 360Vac to 600Vac, and the power will not de-rate throughout the entire range. Another great feature is the conformal coating on the PCBA which allows selected models to be certified to ATEX and Class I, Div 2 for use in hazardous locations. The design conforms to harmonic current emission IEC/EN 61000-3-2, Class A.

Model Information

CliQ II DIN Rail Power Supply

| Model Number | Input Voltage Range | Rated Output Voltage | Rated Output Current |
|----------------|--|----------------------|----------------------|
| DRP024V480W3B□ | 3 x 320-600Vac (3-Phase) or 2 x 360-600Vac (2-Phase) | 24Vdc | 20.0A |

Model Numbering

| DR | P | 024V | 480W | 3 | B | □ |
|----------|--------------|----------------|--------------|-------------|----------------|---|
| DIN Rail | Power Supply | Output Voltage | Output Power | Three Phase | CliQ II Series | A - Metal Case, with Class I, Div 2 N - Metal Case, without Class I, Div 2 |

CliQ II DIN Rail Power Supply

24V 480W 3 Phase / DRP024V480W3B□

Specifications

Input Ratings / Characteristics

| | |
|---------------------------------|--|
| Nominal Input Voltage | 3 x 400-500Vac |
| Input Voltage Range | 3 x 320-600Vac (3-Phase) or 2 x 360-600Vac (2-Phase) |
| Nominal Input Frequency | 50-60Hz |
| Input Frequency Range | 47-63Hz |
| DC Input Voltage Range* | 450-800Vdc |
| Input Current | < 1.00A @ 3 x 400Vac, < 0.75A @ 3 x 500Vac |
| Efficiency at 100% Load | > 91.0% @ 3 x 400Vac & 3 x 500Vac |
| Max Inrush Current (Cold Start) | < 50A @ 3 x 400Vac & 3 x 500Vac |
| Power Factor at 100% Load | > 0.95 @ 3 x 400Vac, > 0.94 @ 3 x 500Vac |
| Leakage Current | < 3.5mA @ 500Vac |

*Safety approval according to IEC/EN/UL 60950-1.

Output Ratings / Characteristics

| | |
|---|---|
| Nominal Output Voltage | 24Vdc |
| Factory Set Point Tolerance | ± 2% (initial set point tolerance from factory) |
| Output Voltage Adjustment Range | 24-28Vdc |
| Output Current | 20.0A (continuously operating at 24V) 30.0A (Power Boost for 5 seconds at 24V, refer to the details in the Functions section) 40.0A (Power Boost for 2 seconds at 24V, refer to the details in the Functions section) |
| Output Power | 480W (continuously operating at 24V) 720W (Power Boost for 5 seconds at 24V, refer to the details in the Functions section) 960W (Power Boost for 2 seconds at 24V, refer to the details in the Functions section) |
| Line Regulation | < 0.5% typ. (@ 3 x 320-600Vac input, 100% load) |
| Load Regulation | < 1% typ. (@ 3 x 320-600Vac input, 0-100% load) |
| PARD (20MHz) | < 150mVpp |
| Rise Time | < 100ms @ nominal input (100% load) |
| Start-up Time | < 1,000ms @ nominal input (100% load) |
| Hold-up Time | > 20ms @ 3 x 400Vac & 3 x 500Vac (100% load) |
| Dynamic Response (Overshoot & Undershoot O/P Voltage) | ± 5% @ 10-90% load |
| Start-up with Capacitive Loads | 10,000µF Max |

CliQ II DIN Rail Power Supply

24V 480W 3 Phase / DRP024V480W3B□

Mechanical

| | | |
|-----------------------------------|--|-------------------------|
| Case Cover / Chassis | Aluminium | |
| Dimensions (L x W x D) | 121 x 140 x 117.3 mm (4.76 x 5.51 x 4.62 inch) | |
| Unit Weight | 1.35 kg (2.98 lb) | |
| Indicator | Green LED (DC OK) | |
| Cooling System | Convection | |
| Terminal | Input | 4 Pins (Rated 600V/35A) |
| | Output | 4 Pins (Rated 300V/30A) |
| Wire | Input | AWG 18-8 |
| | Output | AWG 12-10 |
| Mounting Rail | Standard TS35 DIN Rail in accordance with EN 60715 | |
| Noise (1 Meter from power supply) | Sound Pressure Level (SPL) < 40dBA | |

Environment

| | | |
|-----------------------------|---|--|
| Surrounding Air Temperature | Operating | -25°C to +80°C (Cold Start at -40°C) |
| | Storage | -40°C to +85°C |
| Power De-rating | Vertical Mounting | > 50°C de-rate power by 2.5% / °C, > 70°C de-rate power by 5% / °C |
| Operating Humidity | 5 to 95% RH (Non-Condensing) | |
| Operating Altitude | 0 to 2,500 Meters (8,200 ft.) for ITE application (@ 50°C) 0 to 2,000 Meters (6,560 ft.) for Industrial application (@ 50°C) | |
| Shock Test | Non-Operating | IEC 60068-2-27, 30G (300m/S ²) for a duration of 18ms, 1 time per direction, 2 times in total |
| Vibration | Non-Operating | IEC 60068-2-6, 10Hz to 500Hz @ 30m/S ² (3G peak); 60 min per axis for all X, Y, Z direction |
| Pollution Degree | 2 | |

Protections

| | |
|--------------------------|--|
| Overvoltage | 32V ±10%, SELV Output, Hiccup Mode, Non-Latching (Auto-Recovery) |
| Overload / Overcurrent | > 200% of rated load current, Hiccup Mode, Non-Latching (Auto-Recovery) |
| Over Temperature | < 80°C Surrounding Air Temperature @ 100% load, Non-Latching (Auto-Recovery) |
| Short Circuit | Hiccup Mode, Non-Latching (Auto-Recovery when the fault is removed) |
| Degree of Protection | IP20 |
| Protection Against Shock | Class I with PE* connection |

*PE: Primary Earth

CliQ II DIN Rail Power Supply

24V 480W 3 Phase / DRP024V480W3B□

Reliability Data

| | |
|------------------------|---|
| MTBF | > 500,000 hrs. as per Telcordia SR-332 I/P: 3 x 400Vac, O/P: 100% load, Ta: 25°C |
| Expected Cap Life Time | 10 years (3 x 400Vac & 3x 500Vac, 50% load @ 40°C) |

Safety Standards / Directives

| | | |
|---|-------------------|---|
| Electrical Equipment in Power Installations | | EN 50178 / IEC 62103 |
| Electrical Safety | SIQ Bauart | EN 60950-1 |
| | UL/cUL recognized | UL 60950-1 and CSA C22.2 No. 60950-1 (File No. E191395) |
| | CB scheme | IEC 60950-1 |
| Industrial Control Equipment | UL/cUL listed | UL 508 and CSA C22.2 No. 107.1-01 (File No. E315355) |
| | CSA | CSA C22.2 No. 107.1-01 (File No. 181564) |
| Hazardous Location / ATEX | cCSAus | CSA C22.2 No. 213-M1987, ANSI / ISA 12.12.01:2007 [Class I, Division 2, Group A, B, C, D T4, Ta = -25°C to +80°C (> +50°C derating)] |
| | ATEX | EN 60079-0:2012, EN 60079-15:2010 [⊕ II 3G Ex nA IIC T4 Gc, Ta = -25°C to +80°C (> +50°C derating)] Certificate No. EPS 13 ATEX 1 575 X |
| CE | | In conformance with EMC Directive 2014/30/EU and Low Voltage Directive 2014/35/EU DRP024V480W3BA: In conformance with Equipment for explosive atmospheres (ATEX) directive 2014/34/EU |
| Material and Parts | | RoHS Directive 2011/65/EU Compliant |
| Galvanic Isolation | Input to Output | 4.0KVac |
| | Input to Ground | 2.0KVac |
| | Output to Ground | 1.5KVac |

CliQ II DIN Rail Power Supply

24V 480W 3 Phase / DRP024V480W3B□

EMC

| | | |
|--|----------------|--|
| Emissions (CE & RE) | | CISPR 32, EN 55032, CISPR 11, EN 55011, FCC Title 47: Class B |
| Component Power Supply for General Use | | EN 61204-3 |
| Immunity | | EN 55024, EN 61000-6-2 |
| Electrostatic Discharge | IEC 61000-4-2 | Level 4 Criteria A ¹⁾ Air Discharge: 15kV Contact Discharge: 8kV |
| Radiated Field | IEC 61000-4-3 | Level 3 Criteria A ¹⁾ 80MHz-1GHz, 10V/M, 80% modulation (1KHz) 1.4GHz-2GHz, 3V/M, 80% modulation (1KHz) 2GHz-2.7GHz, 1V/M, 80% modulation (1KHz) |
| Electrical Fast Transient / Burst | IEC 61000-4-4 | Level 3 Criteria A ¹⁾ 2kV |
| Surge | IEC 61000-4-5 | Level 3 Criteria A ¹⁾ Common Mode ²⁾ : 2kV Differential Mode ³⁾ : 1kV |
| Conducted | IEC 61000-4-6 | Level 3 Criteria A ¹⁾ 150kHz-80MHz, 10Vrms |
| Power Frequency Magnetic Fields | IEC 61000-4-8 | Criteria A ¹⁾ 30A/Meter |
| Voltage Dips | IEC 61000-4-11 | 100% dip; 1 cycle (20ms); Self Recoverable |
| Low Energy Pulse Test (Ring Wave) | IEC 61000-4-12 | Level 3 Criteria A ¹⁾ Common Mode ²⁾ : 2kV Differential Mode ³⁾ : 1kV |
| Harmonic Current Emission | | IEC/EN 61000-3-2, Class A |
| Voltage Fluctuation and Flicker | | IEC/EN 61000-3-3 |

1) Criteria A: Normal performance within the specification limits

2) Asymmetrical: Common mode (Line to earth)

3) Symmetrical: Differential mode (Line to line)

CliQ II DIN Rail Power Supply

24V 480W 3 Phase / DRP024V480W3B □

Block Diagram

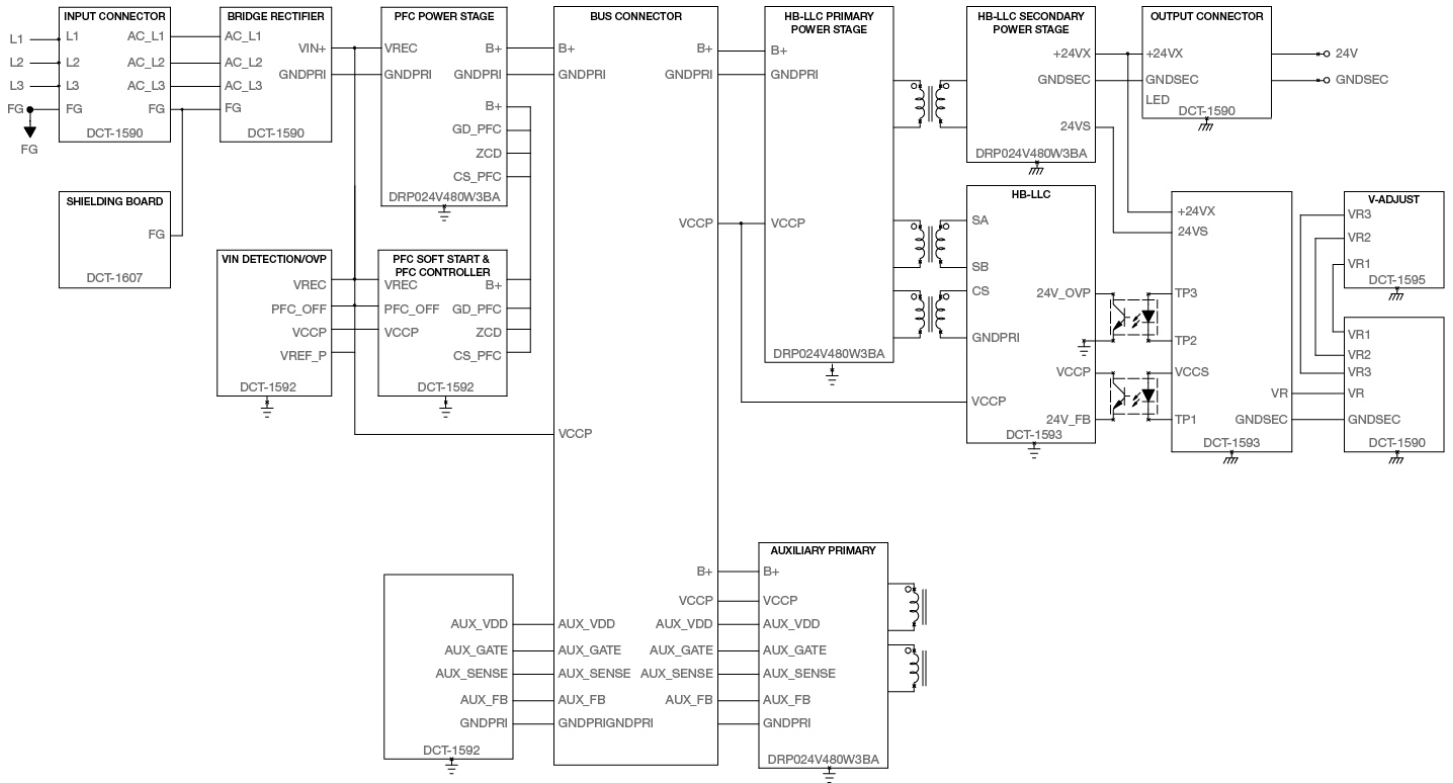

Device Description

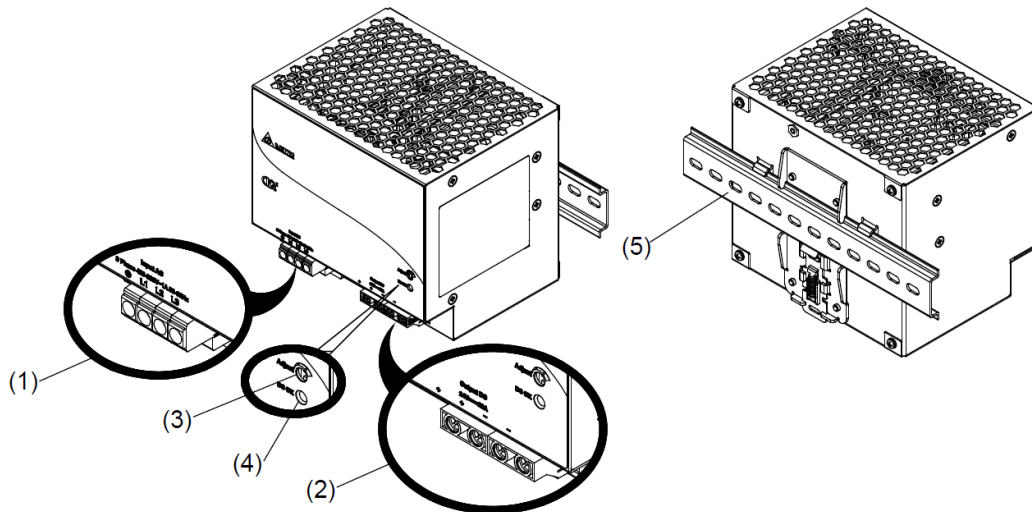

- 1) Input terminal block connector
- 2) Output terminal block connector
- 3) DC Voltage adjustment potentiometer
- 4) DC OK control LED (Green)
- 5) Universal mounting rail system

CliQ II DIN Rail Power Supply

24V 480W 3 Phase / DRP024V480W3B

Dimensions

L x W x D: 121 x 140 x 117.3 mm (4.76 x 5.51 x 4.62 inch)

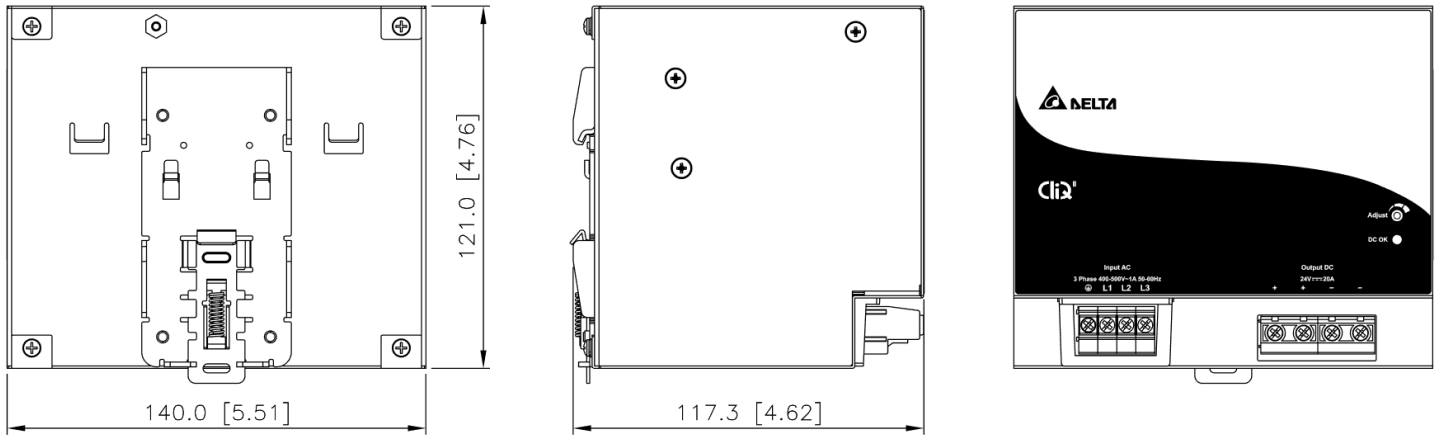

Engineering Data

Output Load De-rating VS Surrounding Air Temperature

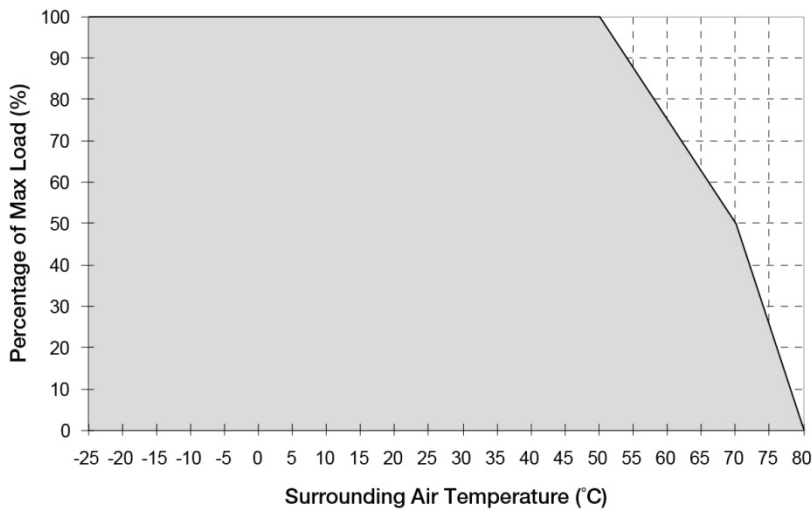

Fig. 1 De-rating for Vertical Mounting Orientation

> 50°C de-rate power by 2.5% / °C,
 > 70°C de-rate power by 5% / °C

Note

1. Power supply components may degrade, or be damaged, when the power supply is continuously used outside the shaded region, refer to the graph shown in Fig. 1.
2. If the output capacity is not reduced when the surrounding air temperature >50°C (Vertical), the device may run into Over Temperature Protection. When activated, the output voltage will go into bouncing mode and will recover when the surrounding air temperature is lowered or the load is reduced as far as necessary to keep the device in working condition.
3. In order for the device to function in the manner intended, it is also necessary to keep a safety distance of 5mm (0.20 inch) for Vertical Mounting with adjacent units while the device is in operation.
4. Depending on the surrounding air temperature and output load delivered by the power supply, the device can be very hot!
5. If the device has to be mounted in any other orientation, please contact info@deltapsu.com for more details.

CliQ II DIN Rail Power Supply

24V 480W 3 Phase / DRP024V480W3B□

Output Load De-rating VS Input Voltage

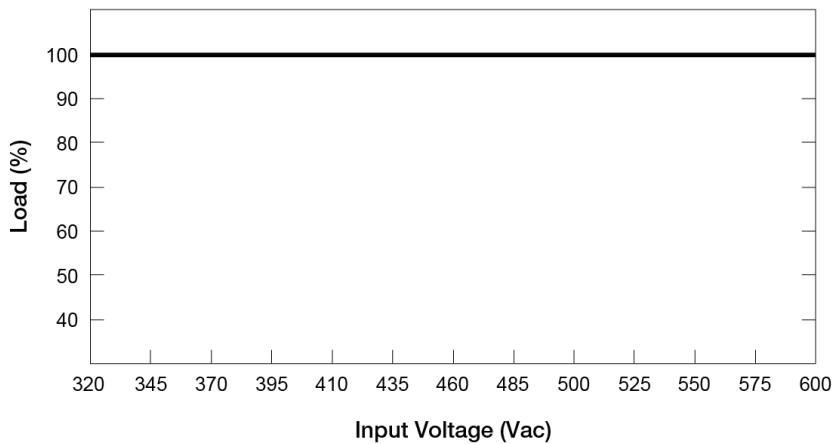

■ No output power de-rating across the entire input voltage range 3 x 320-600Vac (3-Phase) or 2 x 360-600Vac (2-Phase)

Assembly & Installation

The power supply unit (PSU) can be mounted on 35mm DIN rails in accordance with EN 60715. For Vertical Mounting, the device should be installed with input terminal block at the bottom.

Each device is delivered ready to install.

Mounting

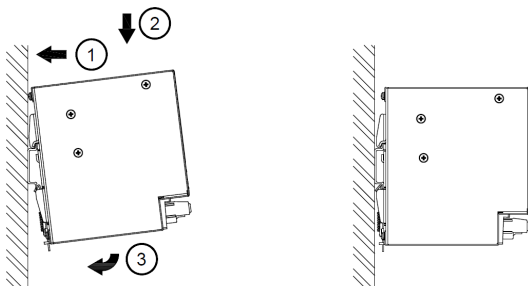

Fig. 2.1 Mounting

Snap on the DIN rail as shown in Fig. 2.1:

1. Tilt the unit upwards and insert it onto the DIN rail.
2. Push downwards until stopped.
3. Press against the bottom front side for locking.
4. Shake the unit slightly to ensure that it is secured.

Dismounting

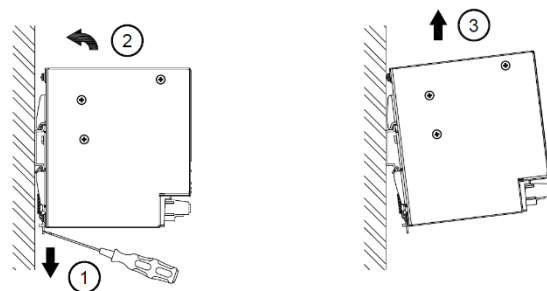

Fig. 2.2 Dismounting

To uninstall, pull or slide down the latch with screw driver as shown in Fig. 2.2. Then slide the power supply unit (PSU) in the opposite direction, release the latch and pull out the power supply unit (PSU) from the rail.

In accordance to EN 60950 / UL 50950, flexible cables require ferrules.

Use appropriate copper cables designed to sustain operating temperature of:

1. 60°C, 60°C / 75°C for USA
2. At least 75°C for ambient not exceeding 50°C, and 90°C for ambient exceeding 50°C for Canada.

CliQ II DIN Rail Power Supply

24V 480W 3 Phase / DRP024V480W3B□

Safety Instructions

■ Vertical Mounting

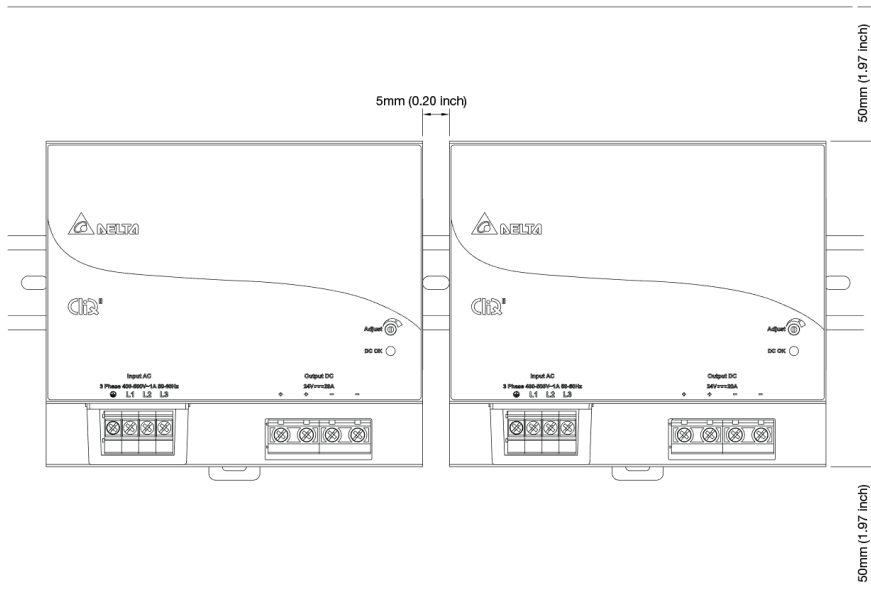

- ALWAYS switch mains of input power OFF before connecting and disconnecting the input voltage to the unit. If mains are not turned OFF, there is risk of explosion / severe damage.
- **To guarantee sufficient convection cooling, keep a distance of 50mm (1.97 inch) above and below the device as well as a lateral distance of 5mm (0.20 inch) to other units.**
- Note that the enclosure of the device can become very hot depending on the surrounding air temperature and load of the power supply. Risk of burns!
- Only plug in and unplug connectors when power is turned off!
- DO NOT insert any objects into the unit.
- Hazardous voltages may be present for up to 5 minutes after the input mains voltage is disconnected. Do not touch the unit during this time.
- The power supplies unit should be installed in minimum IP54 rated enclosure.
- The power supplies are built in units and must be installed in a cabinet or room (condensation free environment and indoor location) that is relatively free of conductive contaminants.
- CAUTION: "For use in a controlled environment".
- **It is NOT advised to install in horizontal mounting orientation, since it may cause damage to the PSU.**

For DRP024V480W3BA:

- The power supplies unit must be installed in an IP54 enclosure or cabinet in the final installation. The enclosure or cabinet must comply with EN60079-0 or EN60079-15.
- Warning: Explosion Hazard - Substitution of components may impair suitability for Class I, Division 2.
- Warning: Explosion Hazard - Do not disconnect equipment or adjust potentiometer unless the power has been switched off or the area is known to be non-hazardous.

CliQ II DIN Rail Power Supply

24V 480W 3 Phase / DRP024V480W3B □

Functions

- Graph illustrating the Start-up Time, Rise Time, and Hold-up Time

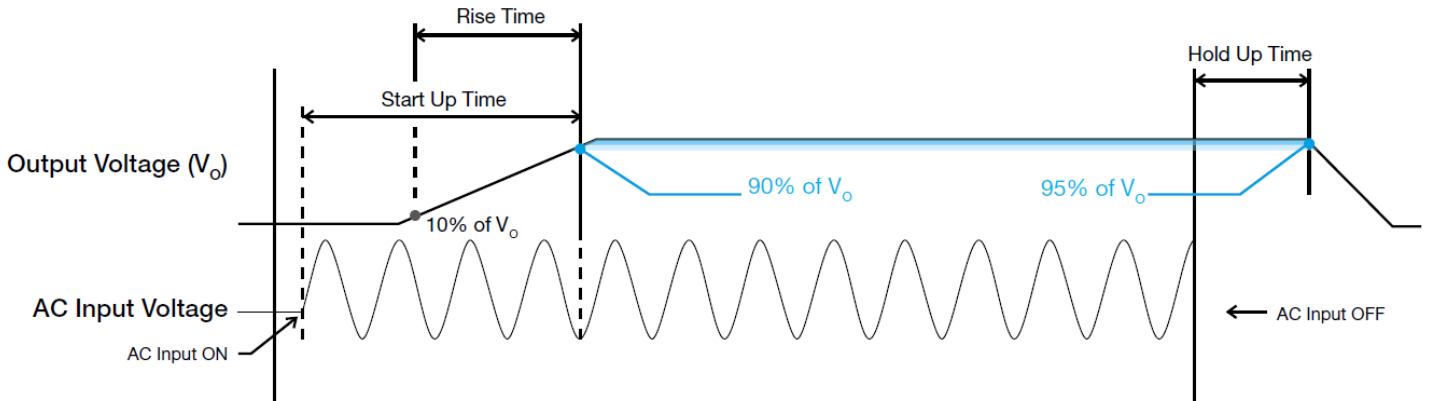

Start-up Time

The time required for the output voltage to reach 90% of its final steady state set value, after the input voltage is applied.

Rise Time

The time required for the output voltage to change from 10% to 90% of its final steady state set value.

Hold-up Time

Time between the collapse of the AC input voltage, and the output falling to 95% of its steady state set value.

Inrush Current

Inrush current is the peak, instantaneous, input current measured and, occurs when the input voltage is first applied. For AC input voltages, the maximum peak value of inrush current will occur during the first half cycle of the applied AC voltage. This peak value decreases exponentially during subsequent cycles of AC voltage.

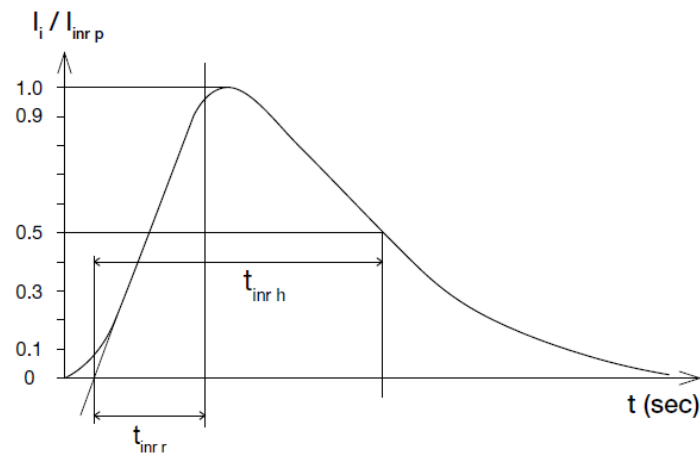

Dynamic Response

The power supply output voltage will remain within $\pm 5\%$ of its steady state value, when subjected to a dynamic load from 10% to 90% of its rated current.

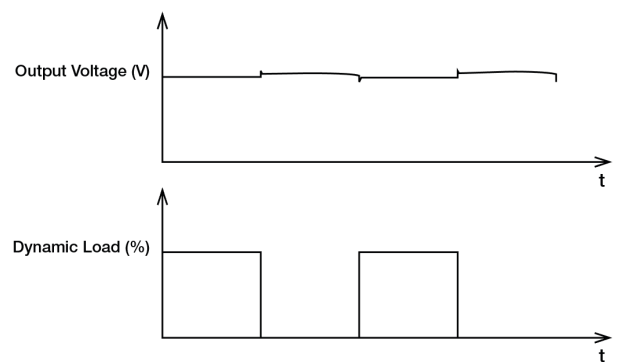

CliQ II DIN Rail Power Supply

24V 480W 3 Phase / DRP024V480W3B □

Power Boost

Power Boost is the reserve power available constantly that allows reliable startup to support sudden and short spike of loads with high inrush current typically during turn on to remove the need of more expensive higher rated power supply unit. After the output has reached its steady state set value, the power supply can support surge loads with a higher short-term power demand up to 200% of maximum rated load (Io Max), for a maximum duration of 2 seconds, or 150% of maximum rated load for a maximum duration of 5 seconds. The Power Boost is also available to repeatedly basis with according to the condition of an average (R.M.S) output power shall not exceed continuous operating condition or refer to duty cycle calculation below.

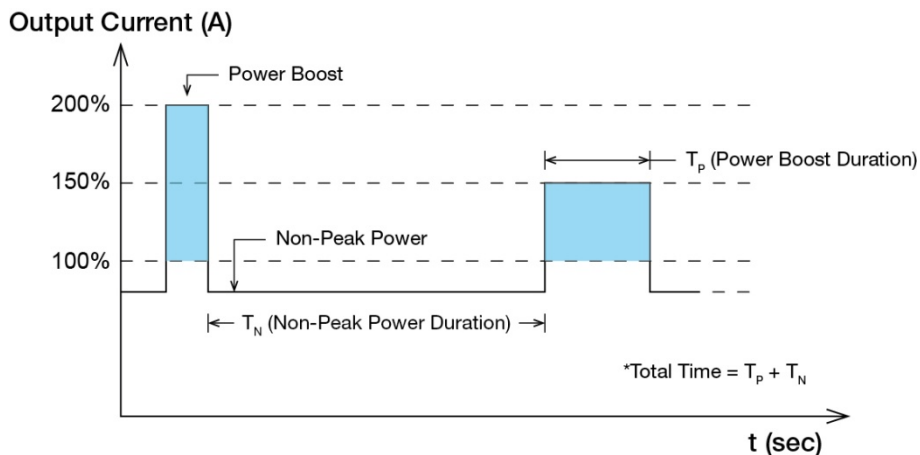

$$Duty\ cycle\ (\%) = \frac{T_p}{Total\ Time}$$

$$Average\ Output\ Power\ (P_{Avg}) = \frac{(Power\ Boost \times T_p) + (Non-Peak\ Power \times T_n)}{Total\ Time}$$

OR

$$Non-Peak\ Power = \frac{(P_{Avg} \times Total\ Time) - (Power\ Boost \times T_p)}{T_n}$$

■ An example of Power Boost and Average Output Power

| Power Boost | Peak Power (W _P) | Power Boost Duration (T _P) | Duty Cycle | Non-Peak Power (W _N) | Non-Peak Power Duration (T _N) | Total Time (T) |
|-------------|------------------------------|--|------------|----------------------------------|---|----------------|
| 200% | 960 | 2 sec | 5% | 455W | 38 sec | 40 sec |
| 150% | 720 | 5 sec | 10% | 453W | 45 sec | 50 sec |
| 150% | 720 | 5 sec | 35% | 351W | 9.3 sec | 14.3 sec |
| 120% | 576 | 10 sec | 20% | 456W | 40 sec | 50 sec |
| 120% | 576 | 10 sec | 35% | 428W | 18.5 sec | 28.5 sec |

It is not recommended to prolong the duration of Power Boost to be longer than the specified duty cycle calculation, this may cause damage to the PSU.

External Input Protection Device

The unit is protected with internal fuse (not replaceable) at L pin and it has been tested and approved on 20A (UL) and 16A (IEC) branch circuits without additional protection device. An external protection device is only required if the supplying branch has an ampacity greater than above. Thus, if an external protective device is necessary, or, utilized, please refer a minimum value in instruction sheet with B or C characteristic breaker.

CliQ II DIN Rail Power Supply

24V 480W 3 Phase / DRP024V480W3B □

Overload & Overcurrent Protections (Auto-Recovery)

The power supply's Overload (OLP) and Overcurrent (OCP) Protections will be activated when output current exceeds 200% of I_O (Max load). In such occurrence, the V_O will start to droop and once the power supply has reached its maximum power limit, the protection is activated and the power supply will go into "Hiccup mode" (Auto-Recovery). The power supply will recover once the fault condition of the OLP and OCP is removed and I_O is back within the specifications.

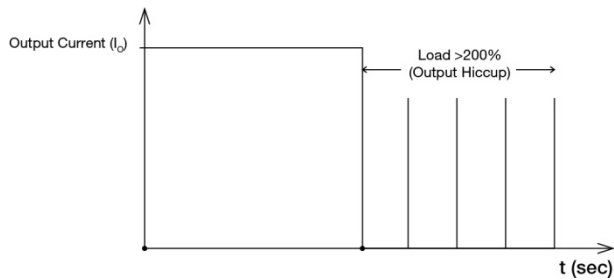

It is not recommended to prolong the duration of I_O when it is <200% but >100%, since it may cause damage to the PSU.

Short Circuit Protection (Auto-Recovery)

The power supply's output OLP/OCP function also provides protection against short circuits. When a short circuit is applied, the output current will operate in "Hiccup mode", as shown in the illustration in the OLP/OCP section on this page. The power supply will return to normal operation after the short circuit is removed.

Overvoltage Protection (Auto-Recovery)

The power supply's overvoltage circuit will be activated when its internal feedback circuit fails. The output voltage shall not exceed its specifications defined on Page 3 under "Protections".

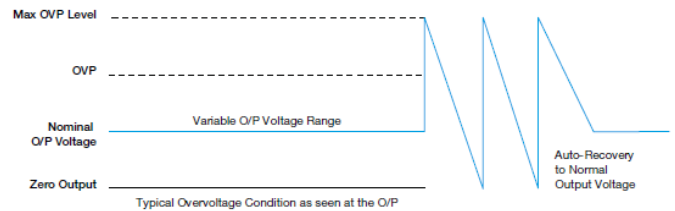

Over Temperature Protection (Auto-Recovery)

As described in load de-rating section, the power supply also has Over Temperature Protection (OTP). In the event of a higher operating temperature at 100% load, the power supply will run into OTP when the operating temperature is beyond what is recommended in the de-rating graph. When activated, the output voltage will go into bouncing mode until the temperature drops to its normal operating temperature as recommended in the de-rating graph.

CliQ II DIN Rail Power Supply

24V 480W 3 Phase / DRP024V480W3B □

Operating Mode

■ Redundant Operation

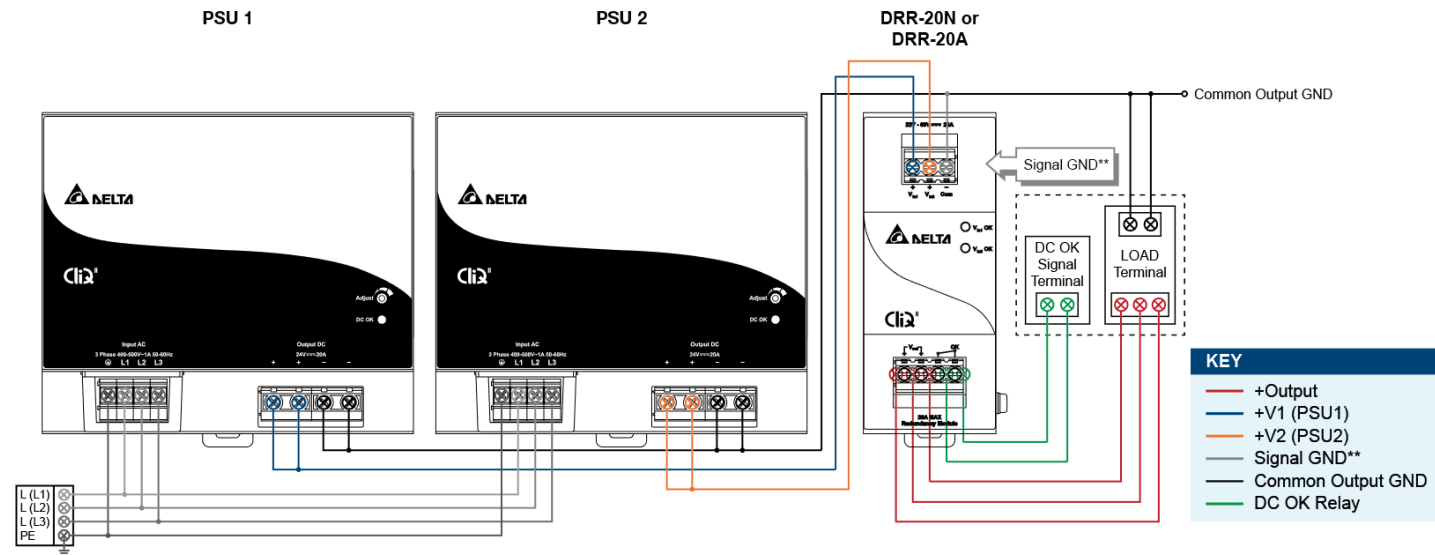

**The Signal GND in the DRR module is for the built-in LED and DC OK signals. The Output GND terminals from the two PSU's do not need to be connected to the Signal GND terminal.

Fig. 3 Redundant Operation Connection Diagram

In order to ensure proper redundant operation for the power supply unit (PSU), the output voltage difference between the two units must be kept at 0.45~0.50V for 24V supplies. Follow simple steps given below to set them up for the redundant operation:

Step 1.
Measure output voltage of PSU 1 and PSU 2. If PSU 1 is the master unit, then V_o of PSU 1 must be higher than PSU 2. In order to set the output voltage, individually connect the power supply to 50% of rated load at any line voltage of 3 x 320-600Vac (3-Phase) or 2 x 360-600Vac (2-Phase), and set the PSU 1 and PSU 2 output voltage.

Step 2.
Connect the power supply units PSU 1 and PSU 2 to $V_{in 1}$ & $V_{in 2}$, respectively, of the DRR-20N (or 20A) module shown on the diagram at the top.

Step 3.
Connect the system load from V_{out} . Please note that output voltage V_{out} from DRR module will be = V_o (output voltage of power supply) - V_{drop}^* (in DRR module).

* V_{drop} will vary from 0.60V to 0.90V (Typical 0.65V) depending on the load current and surrounding air temperature

CliQ II DIN Rail Power Supply

24V 480W 3 Phase / DRP024V480W3B □

■ Parallel Operation

The power supply units (PSUs) can also be used for parallel operation in order to increase the output power. The difference in output voltage between the two units must be kept to within 25mV of each other. This difference must be verified with the same output load connected independently to each unit.

Parameters such as EMI, inrush current, leakage current, PARD, start up time will be different from those on the datasheet, when two units are connected in parallel. The user will need to verify that any differences will still allow the two power supplies connected in parallel will work properly in their product/application.

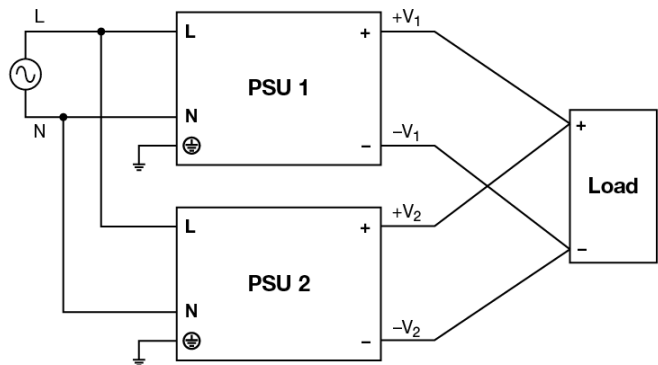

Fig. 4 Parallel Operation Connection Diagram

Others

Delta RoHS Compliant



Restriction of the usage of hazardous substances

The European directive 2011/65/EU limits the maximum impurity level of homogeneous materials such as lead, mercury, cadmium, chrome, polybrominated flame retardants PBB and PBDE for the use in electrical and electronic equipment. RoHS is the abbreviation for “Restriction of the use of certain hazardous substances in electrical and electronic equipment”.

This product conforms to this standard.

Conformal Coating

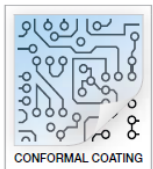

The Protective Coating Technology

Delta Electronics Group has designed the perfect dipping technique which penetrates everywhere including under device, and prevents leakage. The conformal coating dipping can be applied to PCBAs or circuit board. The coating preserves the performance of precision electronic primarily by preventing ionizable contaminants such as salt from reaching circuit nodes, where the material slumps around sharp edges. This can be a problem especially in highly conversing atmosphere.

PFC – Norm EN 61000-3-2

Line Current Harmonic content

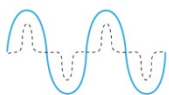

Typically, the input current waveform is not sinusoidal due to the periodical peak charging of the input capacitor. In industrial environment, complying with EN 61000-3-2 is only necessary under special conditions. Complying to this standard can have some technical drawbacks, such as lower efficiency as well as some commercial aspects such as higher purchasing costs. Frequently, the user does not profit from fulfilling this standard, therefore, it is important to know whether it is mandatory to meet this standard for a specific application.

Attention

Delta provides all information in the datasheets on an “AS IS” basis and does not offer any kind of warranty through the information for using the product. In the event of any discrepancy between the information in the catalog and datasheets, the datasheets shall prevail (please refer to www.DeltaPSU.com for the latest datasheets information). Delta shall have no liability of indemnification for any claim or action arising from any error for the provided information in the datasheets. Customer shall take its responsibility for evaluation of using the product before placing an order with Delta.

Delta reserves the right to make changes to the information described in the datasheets without notice.

X-ON Electronics

Largest Supplier of Electrical and Electronic Components

Click to view similar products for [DIN Rail Power Supplies](#) category:

Click to view products by [Delta](#) manufacturer:

Other Similar products are found below :

[PS-S6024](#) [DVP01PU-S](#) [DVP06AD-S](#) [DVP06XA-S](#) [DVDPNET-SL](#) [DVPDT01-S](#) [DVPPS01](#) [PS-6012](#) [PS9Z-5R1G](#) [PS-C24024](#)
[DVP08ST11N](#) [DVPACAB530](#) [DVPCOPM-SL](#) [DVPEN01-SL](#) [DVPPF01-S](#) [ADNB008-48-1PM-C](#) [ADNB017-24-1PM-C](#) [ADNB040-24-1PM-C](#) [ADNB034-12-1PM-C](#) [SS14011524](#) [PS-UPS40](#) [PSC-6024](#) [PSD-A60W12](#) [96PS-A120WDIN](#) [PSD-A60W48](#) [PSD-A40W12](#) [PSD-A40W24](#) [SMP21-L20-DC24V-5A](#) [PSD-A40W48](#) [S8T-DCBU-02](#) [PS-S4024](#) [NTPS-24-1.3](#) [ZI-20](#) [PST-96024](#) [S82YVSC4P](#) [PS-S4005](#) [PS-10024](#) [PS-S10024](#) [PS-C12024](#) [PSP-480S24](#) [PS-C48024](#) [PSC-2024](#) [PSC-4012](#) [PSC-4048](#) [PSC-9615](#) [PSC-15124](#) [PSC-15148](#) [PSC-24148](#) [PSC-48148](#) [TRIO-PS-2G/1AC/12DC/5/C2LP](#)