

# PMC Panel Mount Power Supply

12 V 60 W 1 Phase, NEC Class 2 / PMC-12V060W1N□

## PMC

### Highlights & Features

- Universal AC input voltage without power de-rating
- Full corrosion resistant Aluminium chassis
- NEC Class 2 power supply and Limited Power Source (LPS) approvals
- High MTBF > 700,000 hrs. as per Telcordia SR-332
- Wide operating temperature range from -20°C to 70°C
- Conformal Coating (Class I, Div 2 Hazardous Locations Ready)
- Certified according to IEC/EN/UL 62368-1

### Safety Standards



CB Certified for worldwide use

**Model Number:** PMC-12V060W1N□  
**Unit Weight:** 0.28 kg (0.62 lb)  
**Dimensions (L x W x H):** 128 x 97 x 38 mm  
 (5.04 x 3.82 x 1.50 inch)



### General Description

Delta's PMC series of panel mount power supply offers a nominal output voltage of 12 V, 60 W output power ranging with NEC Class 2 power supply and Limited Power Source (LPS) approvals. The PMC-12V060W1NA comes with a wide temperature range from -20°C to +70°C and conformal coating on PCBA (Class I, Div 2 Hazardous Locations Ready) to protect against chemical and dust pollutants. The PMC series also offers overvoltage and overload protection. Using a wide input voltage range design, it is compatible worldwide. The input also includes DC operating voltage from 125-375 Vdc. Best of all, this excellent design and quality does not come with a big price tag.

### Model Information

PMC Panel Mount Power Supply

| Model Number   | Input Voltage Range      | Rated Output Voltage | Rated Output Current |
|----------------|--------------------------|----------------------|----------------------|
| PMC-12V060W1NA | 85-264 Vac (125-375 Vdc) | 12 Vdc               | 5.00 A               |

### Model Numbering

| PMC        | 12 V           | 060 W        | 1            | N           | □  |
|------------|----------------|--------------|--------------|-------------|--|
| PMC Series | Output Voltage | Output Power | Single Phase | NEC Class 2 | Connector Type<br>A – Terminal Block<br>J – IP20 Connector*<br>L – Front Face* |

\*Options



# PMC Panel Mount Power Supply

## 12 V 60 W 1 Phase, NEC Class 2 / PMC-12V060W1N□

### Specifications

#### Input Ratings / Characteristics

|                          |  |
|--------------------------|--|
| Nominal Input Voltage    | 100-240 Vac                                  |
| Input Voltage Range      | 85-264 Vac                                   |
| Nominal Input Frequency  | 50-60 Hz                                     |
| Input Frequency Range    | 47-63 Hz                                     |
| Nominal DC Input Voltage | 125-250 Vdc                                  |
| DC Input Voltage Range*  | 125-375 Vdc                                  |
| Input Current            | < 1.35 A @ 115 Vac, < 0.90 A @ 230 Vac       |
| Efficiency at 100% Load  | > 86.0% @ 115 Vac, > 87.0% @ 230 Vac         |
| Max Power Dissipation    | 0% load < 1.00W @ 115Vac, < 1.50W @ 230Vac   |
|                          | 100% load < 9.80W @ 115Vac, < 8.95W @ 230Vac |
| Max Inrush Current       | < 50 A @ 115 Vac, < 100 A @ 230 Vac          |
| Leakage Current          | < 1 mA @ 240 Vac                             |

\*Safety approval according to IEC/EN/UL 60950-1 and IEC/EN/UL 62368-1.

#### Output Ratings / Characteristics\*\*

|  |   |
|--|---|
| Nominal Output Voltage                                   | 12 Vdc  |
| Factory Set Point Tolerance                              | 12 Vdc $\pm$ 2%   |
| Output Voltage Adjustment Range                          | 12-14 Vdc   |
| Output Current   | 5.00 A (60 W max.)  |
| Output Power   | 60 W  |
| Line Regulation  | < 0.5% (@ 85-264 Vac input, 100% load)  |
| Load Regulation  | < 1.0% (@ 85-264 Vac input, 0-100% load)  |
| PARD*** (20MHz)  | < 100 mVpp @ 25°C & 50°C<br>< 150 mVpp @ -10°C & -20°C  |
| Rise Time  | < 60 ms @ nominal input (100% load)   |
| Start-up Time  | < 2500 ms @ nominal input (100% load)   |
| Hold-up Time   | > 15 ms @ 115 Vac, > 80 ms @ 230 Vac (100% load)  |
| Dynamic Response<br>(Overshoot & Undershoot O/P Voltage) | $\pm$ 5% @ 85-264Vac input, 0-100% load<br>(Slew Rate: 0.1A/ $\mu$ s, 50% duty cycle @ 5Hz to 1KHz) |
| Start-up with Capacitive Loads                           | 5,000 $\mu$ F Max   |

\*\*For power de-rating from 50°C to 70°C, see power de-rating on page 3.

\*\*\*PARD is measured with an AC coupling mode, 5cm wires, and in parallel with 0.1 $\mu$ F ceramic capacitor.

# PMC Panel Mount Power Supply

## 12 V 60 W 1 Phase, NEC Class 2 / PMC-12V060W1N□

### Mechanical

|                                   |  |                           |
|-----------------------------------|--|---------------------------|
| Case Chassis / Cover              | Aluminium                                  |                           |
| Dimensions (L x W x H)            | 128 x 97 x 38 mm (5.04 x 3.82 x 1.50 inch) |                           |
| Unit Weight                       | 0.28 kg (0.62 lb)                          |                           |
| Indicator                         | Green LED                                  | DC OK                     |
| Cooling System                    | Convection                                 |                           |
| Terminal                          | Input and Output                           | 5 Pins (Rated 300 V/15 A) |
| Wire                              | PMC-12V060W1N <u>A</u>                     | AWG 20-14                 |
|                                   | PMC-12V060W1N <u>J</u>                     | AWG 20-12                 |
|                                   | PMC-12V060W1N <u>L</u>                     | AWG 20-12                 |
| Noise (1 Meter from power supply) | Sound Pressure Level (SPL) < 40 dBA        |                           |

### Environment

|                             |  |  |
|-----------------------------|--|--|
| Surrounding Air Temperature | Operating  | -20°C to +70°C   |
|                             | Storage  | -25°C to +85°C   |
| Power De-rating             | < -10°C de-rate power by 2.0% / °C,<br>> 50°C de-rate power by 2.5% / °C |  |
| Operating Humidity          | 5 to 95% RH (Non-Condensing)   |  |
| Operating Altitude          | 0 to 3,000 Meters (9,840 ft)   |  |
| Shock Test                  | Non-Operating  | IEC 60068-2-27, 30 G (300 m/S <sup>2</sup> ) for a duration of 18 ms,<br>1 times per direction, 2 times in total |
| Vibration                   | Non-Operating  | IEC 60068-2-6, 10 Hz to 150 Hz @ 50 m/S <sup>2</sup> (5G peak);<br>20 min per axis for all X, Y, Z direction     |
| Over Voltage Category       | II   |  |
| Pollution Degree            | 2  |  |

### Protections

|                          |   |
|--------------------------|---|
| Overvoltage              | < 17.6 V, SELV Output, Non-Latching (Auto-Recovery)                             |
| Overload / Overcurrent   | > 110-160% of rated load, Hiccup Mode,<br>Non-Latching (Auto-Recovery)          |
| Over Temperature         | < 75°C Surrounding Air Temperature @ 100% load,<br>Non-Latching (Auto-Recovery) |
| Short Circuit            | Hiccup Mode, Non-Latching<br>(Auto-Recovery when the fault is removed)          |
| Internal Fuse at L pin   | T3.15AH   |
| Protection Against Shock | Class I with PE* connection   |

\*PE: Primary Earth

### Reliability Data

|                        |   |
|------------------------|---|
| MTBF                   | > 700,000 hrs. as per Telcordia SR-332<br>I/P: 115Vac, O/P: 100% load, Ta: 25°C |
| Expected Cap Life Time | 10 years (115 Vac & 230 Vac, 50% load @ 40°C)                                   |

# PMC Panel Mount Power Supply

## 12 V 60 W 1 Phase, NEC Class 2 / PMC-12V060W1N□

### Safety Standards / Directives

|                          |                      |  |
|--------------------------|----------------------|--|
| Safety Entry Low Voltage |                      | SELV (IEC 60950-1)   |
| Electrical Safety        | TUV Bauart           | EN 62368-1, LPS, NEC Class 2   |
|                          | UL/cUL recognized to | UL 60950-1 and CSA C22.2 No. 60950-1 (File No. E191395),<br>UL 62368-1 and CSA C22.2 No. 62368-1 (File No. E191395)                            |
|                          | CB scheme            | IEC 60950-1, IEC 62368-1, LPS  |
|                          | KC                   | K 60950-1  |
|                          | BIS                  | IS 13252-1   |
|                          | UKCA                 | BS EN 62368-1  |
| CE                       |                      | In conformance with EMC Directive 2014/30/EU and Low Voltage Directive 2014/35/EU  |
| UKCA                     |                      | In conformance with Electrical Equipment (Safety) Regulations 2016 No. 1011 and<br>The Electromagnetic Compatibility Regulations 2016 No. 1091 |
| Galvanic Isolation       | Input to Output      | 3.0 KVac   |
|                          | Input to Ground      | 1.5 KVac   |
|                          | Output to Ground     | 0.5 KVac   |

### EMC

|                                   |                |  |
|-----------------------------------|----------------|--|
| Emissions (CE & RE)               |                | Generic Standards: CISPR 32, EN/BS EN 55032,<br>FCC Title 47: Class B, (Class A for DC input)                  |
| Immunity                          |                | Generic Standards: EN/BS EN 55024  |
| Electrostatic Discharge           | IEC 61000-4-2  | Level 4 Criteria A <sup>1)</sup><br>Air Discharge: 15 kV<br>Contact Discharge: 8 kV                            |
| Radiated Field                    | IEC 61000-4-3  | Level 3 Criteria A <sup>1)</sup><br>80 MHz-1 GHz, 10 V/M, 80% modulation (1 KHz)                               |
| Electrical Fast Transient / Burst | IEC 61000-4-4  | Level 3 Criteria A <sup>1)</sup><br>2 kV   |
| Surge                             | IEC 61000-4-5  | Level 3 Criteria A <sup>1)</sup><br>Common Mode <sup>2)</sup> : 2 kV<br>Differential Mode <sup>3)</sup> : 2 kV |
| Conducted                         | IEC 61000-4-6  | Level 3 Criteria A <sup>1)</sup><br>150 kHz-80 MHz, 10 Vrms  |
| Power Frequency Magnetic Fields   | IEC 61000-4-8  | Criteria A <sup>1)</sup><br>10 A/Meter (1 A/Meter for DC input)  |
| Voltage Dips and Interruptions    | IEC 61000-4-11 | 100% dip; 1 cycle (20 ms); Self Recoverable  |
| Low Energy Pulse Test (Ring Wave) | IEC 61000-4-12 | Level 3 Criteria A <sup>1)</sup><br>Common Mode <sup>2)</sup> : 2 kV<br>Differential Mode <sup>3)</sup> : 1 kV |
| Voltage Fluctuation and Flicker   |                | IEC/EN/BS EN 61000-3-3   |

1) Criteria A: Normal performance within the specification limits

2) Asymmetrical: Common mode (Line to earth)

3) Symmetrical: Differential mode (Line to line)

# PMC Panel Mount Power Supply

## 12 V 60 W 1 Phase, NEC Class 2 / PMC-12V060W1N□

### Block Diagram

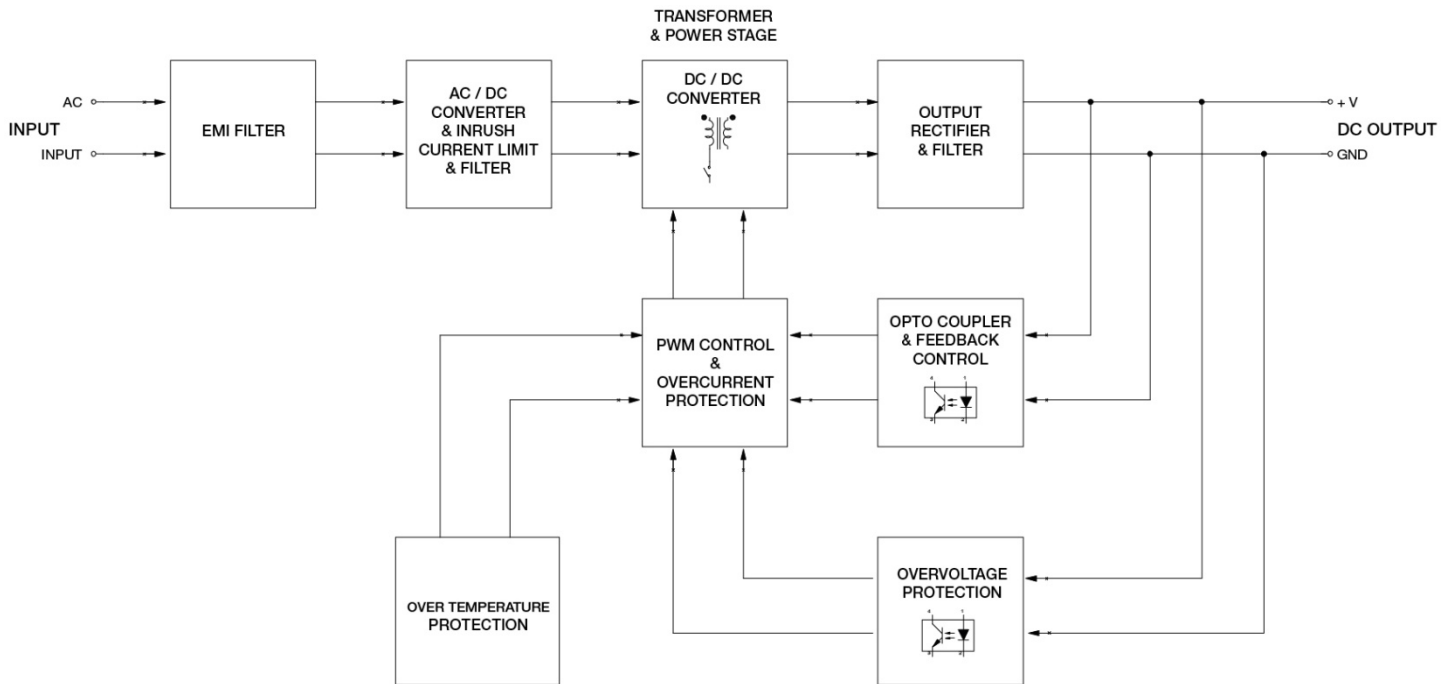

### Device Description

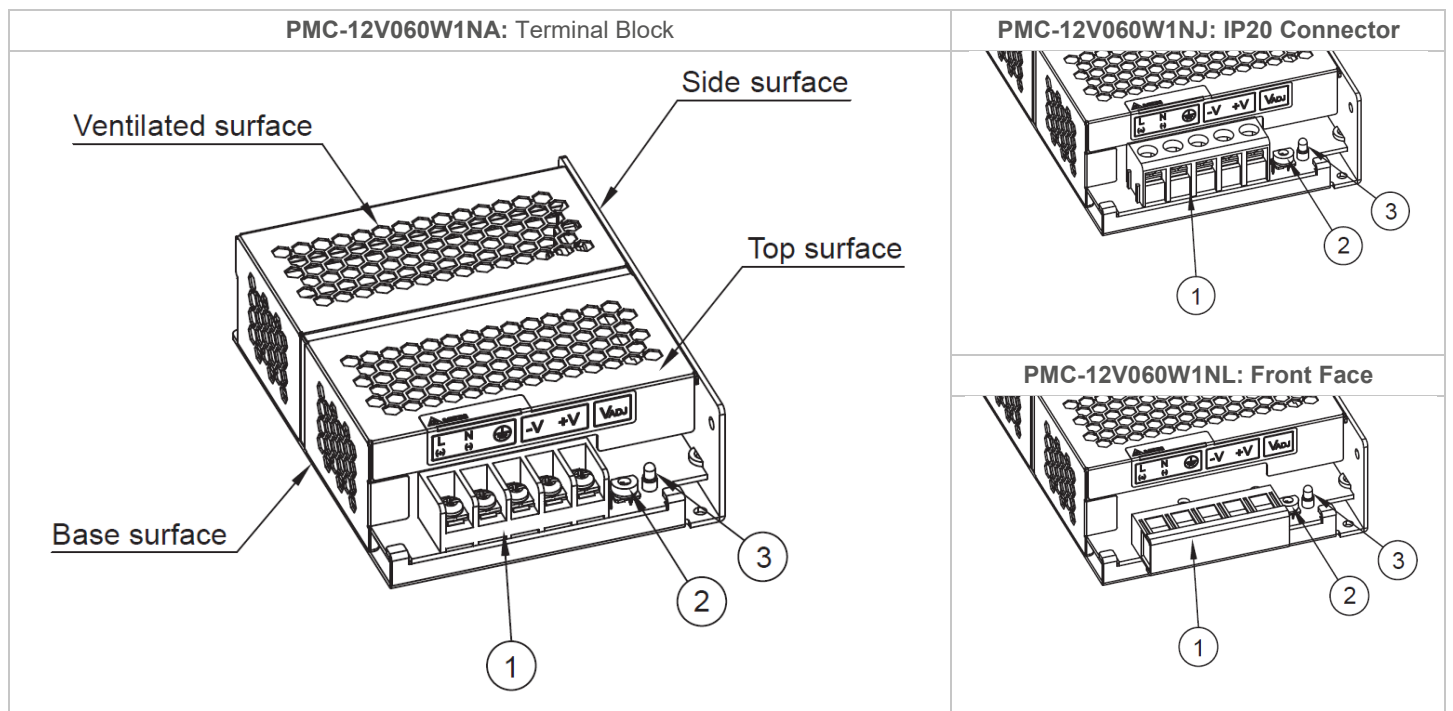

- 1) Input & Output terminal block connector
- 2) DC voltage adjustment potentiometer
- 3) DC OK control LED (Green)

# PMC Panel Mount Power Supply

## 12 V 60 W 1 Phase, NEC Class 2 / PMC-12V060W1N□

### Dimensions

L x W x H: 128 x 97 x 38 mm (5.04 x 3.82 x 1.50 inch) (PMC-12V060W1NA and PMC-12V060W1NJ)

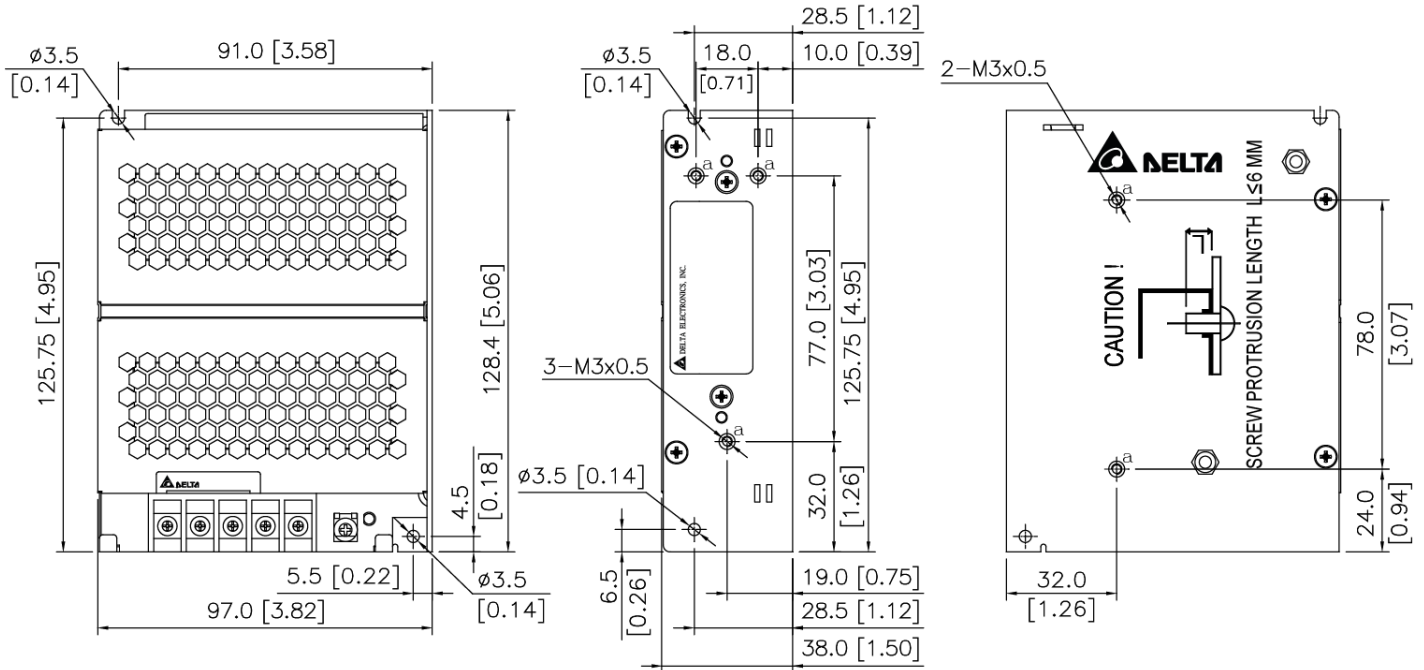

### Engineering Data

#### Output Load De-rating VS Surrounding Air Temperature

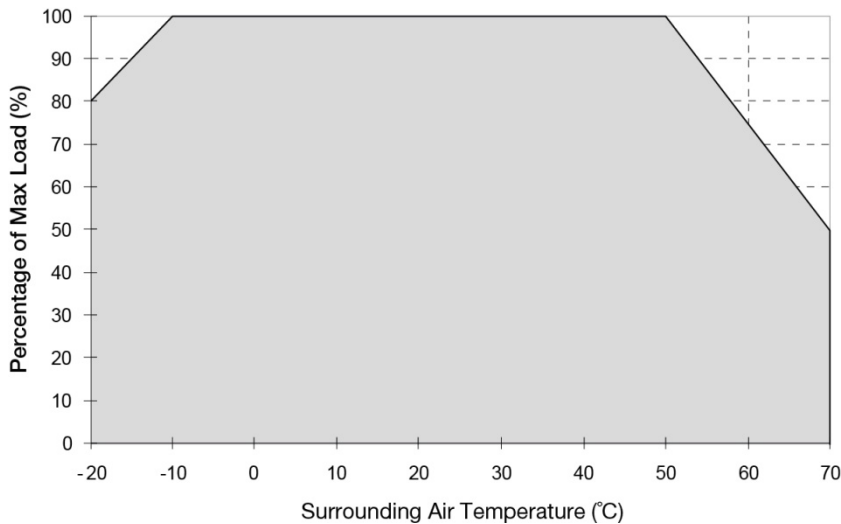

**Fig. 1 De-rating for Vertical and Horizontal Mounting Orientation**

< -10°C de-rate power by 2.0% / °C  
> 50°C de-rate power by 2.5% / °C

#### Note

1. Power supply components may degrade, or be damaged, when the power supply is continuously used outside the shaded region, refer to the graph shown in Fig. 1.
2. If the output capacity is not reduced when the surrounding air temperature exceeds its specification as defined on Page 3 under "Environment", the device may run into Over Temperature Protection. When activated, the output voltage will go into bouncing mode and will recover when the surrounding air temperature is lowered or the load is reduced as far as necessary to keep the device in working condition.
3. In order for the device to function in the manner intended, it is also necessary to keep a safety distance as recommended in the safety instructions while the device is in operation.
4. Depending on the surrounding air temperature and output load delivered by the power supply, the device can be very hot!
5. If the device has to be mounted in any other orientation, please contact [info@deltapsu.com](mailto:info@deltapsu.com) for more details.

# PMC Panel Mount Power Supply

## 12 V 60 W 1 Phase, NEC Class 2 / PMC-12V060W1N□

### Output De-rating VS. Input Voltage

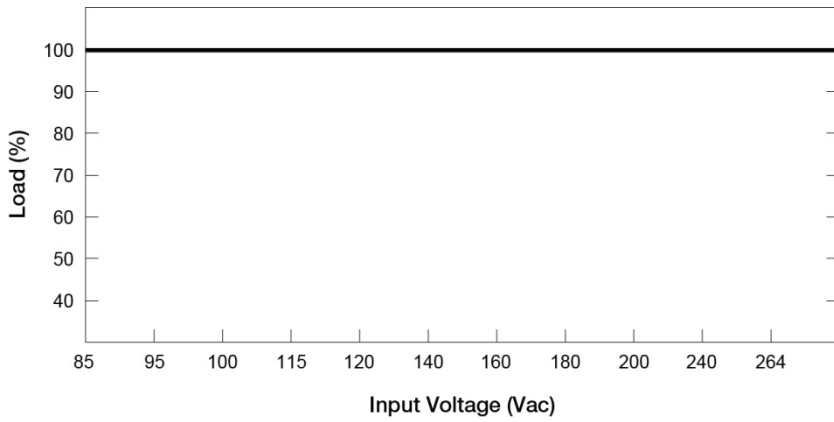

■ No output power de-rating across the entire input voltage range

### Assembly & Installation

#### Mounting

- Ⓐ Mounting holes for power supply assembly onto the mounting surface.  
The power supply shall be mounted on minimum 2 mounting holes using M3 screw minimum 5 mm (0.20 inch) length.
- Ⓑ This surface belongs to customer's end system or panel where the power supply is mounted.
- Ⓒ Connector

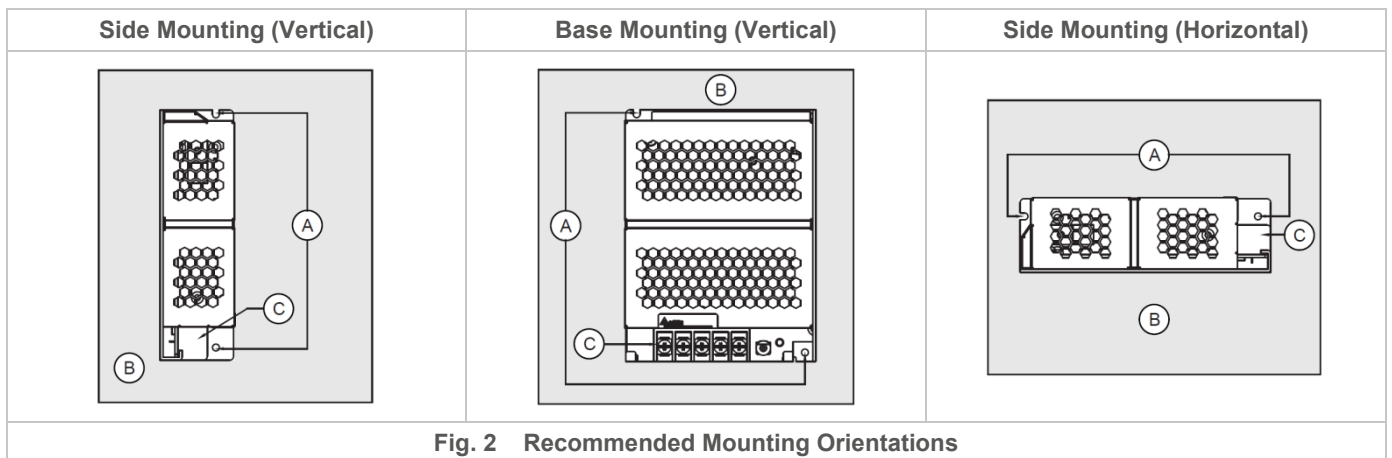

- Use flexible cable (stranded or solid) with the following sizes:

| PMC-12V060W1N <u>A</u> | PMC-12V060W1N <u>J</u> | PMC-12V060W1N <u>L</u> |
|------------------------|------------------------|------------------------|
| AWG 20-14              | AWG 20-12              | AWG 20-12              |

- PMC-12V060W1NA / PMC-12V060W1NJ / PMC-12V060W1NL: The torque at the Connector shall not exceed 13 Kgf.cm. The insulation stripping length should not exceed 0.275" or 7 mm

# PMC Panel Mount Power Supply

## 12 V 60 W 1 Phase, NEC Class 2 / PMC-12V060W1N□

### Installation of Mounting Accessories

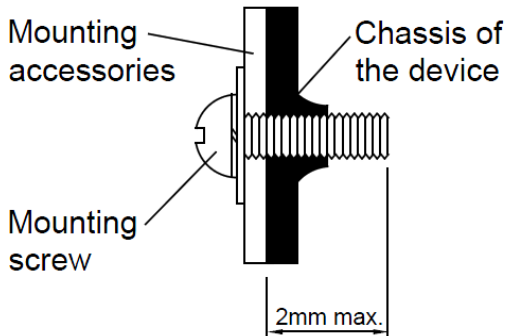

- Only use M3 screw  $\leq 6$  mm through the base mounting holes. This is to keep a safety distance between the screw and internal components.
- Recommended mounting tightening torque: 4~8 Kgf.cm.

### Safety Instructions

- To ensure sufficient convection cooling, always maintain a safety distance of  $\geq 20$  mm (0.79 inch) from all ventilated surfaces while the device is in operation.
- The device is not recommended to be placed on low thermal conductive surface, for example, plastics.
- Note that the enclosure of the device can become very hot depending on the ambient temperature and load of the power supply. Do not touch the device while it is in operation or immediately after power is turned OFF. Risk of burning!
- Do not touch the terminals while power is being supplied. Risk of electric shock.
- Prevent any foreign metal, particles or conductors from entering the device through the openings during installation. It may cause: Electric shock; Safety Hazard; Fire; Product failure
- Warning: When connecting the device, secure Earth connection before connecting L and N. When disconnecting the device, remove L and N connections before removing the Earth connection.



# PMC Panel Mount Power Supply

12 V 60 W 1 Phase, NEC Class 2 / PMC-12V060W1N□

## Functions

- Graph illustrating the Start-up Time, Rise Time, and Hold-up Time

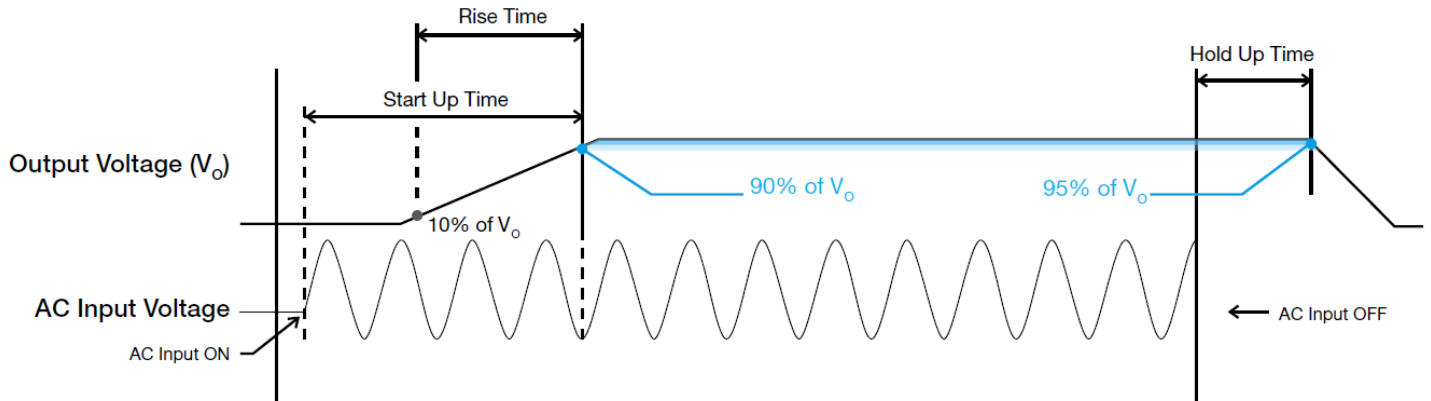

## Start-up Time

The time required for the output voltage to reach 90% of its final steady state set value, after the input voltage is applied.

## Rise Time

The time required for the output voltage to change from 10% to 90% of its final steady state set value.

## Hold-up Time

Time between the collapse of the AC input voltage, and the output falling to 95% of its steady state set value.

## Inrush Current

Inrush current is the peak, instantaneous, input current measured and, occurs when the input voltage is first applied. For AC input voltages, the maximum peak value of inrush current will occur during the first half cycle of the applied AC voltage. This peak value decreases exponentially during subsequent cycles of AC voltage.

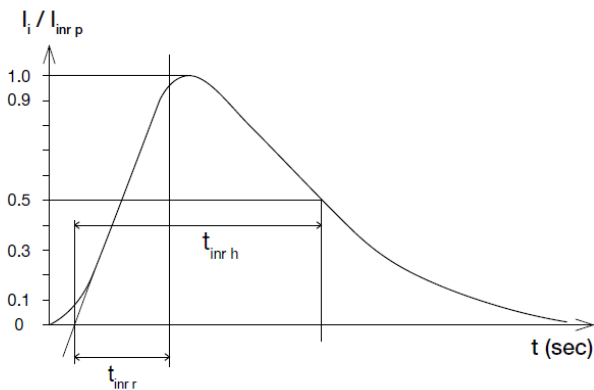

## Dynamic Response

The power supply output voltage will remain within  $\pm 5\%$  of its steady state value, when subjected to a dynamic load from 0% to 100% of its rated current.

- 50% duty cycle / 5Hz to 1KHz

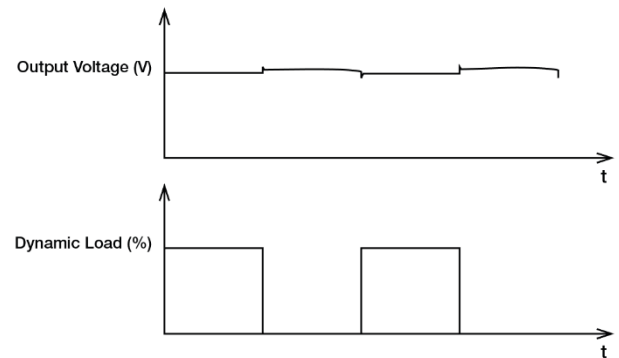

# PMC Panel Mount Power Supply

## 12 V 60 W 1 Phase, NEC Class 2 / PMC-12V060W1N□

### Overload & Overcurrent Protections (Auto-Recovery)

The power supply's Overload (OLP) and Overcurrent (OCP) Protections will be activated when output current ( $I_o$ ) exceeds its specification as defined on Page 3 under "Protections". In such occurrence, the output voltage ( $V_o$ ) will start to droop and once the power supply has reached its maximum power limit, the protection is activated and the power supply will go into "Hiccup mode" (Auto-Recovery). The power supply will recover once the fault condition of the OLP and OCP is removed and  $I_o$  is back within the specifications.

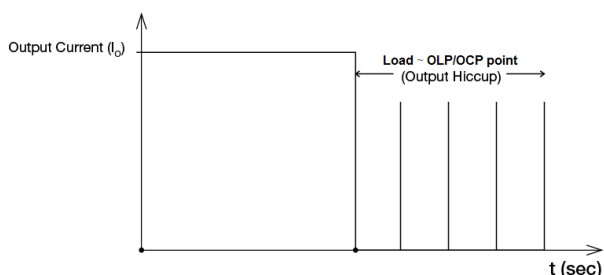

It is not recommended to prolong the duration of  $I_o$  when it is less than OLP/OCP point, but greater than 100%, since it may cause damage to the PSU.

### Short Circuit Protection (Auto-Recovery)

The power supply's output OLP/OCP function also provides protection against short circuits. When a short circuit is applied, the output current will operate in "Hiccup mode", as shown in the illustration in the OLP/OCP section on this page. The power supply will return to normal operation after the short circuit is removed.

### Overvoltage Protection (Auto-Recovery)

The power supply's overvoltage circuit will be activated when its internal feedback circuit fails. The output voltage shall not exceed its specifications defined on Page 3 under "Protections".

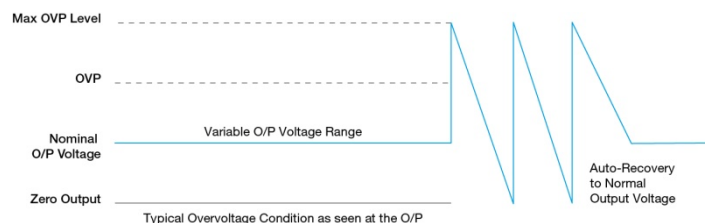

### Over Temperature Protection (Auto-Recovery)

As mentioned above, the power supply also has Over Temperature Protection (OTP). In the event of a higher operating temperature at 100% load, the power supply will run into OTP when the operating temperature is beyond what is recommended in the de-rating graph. When activated, the output voltage will go into bouncing mode until the temperature drops to its normal operating temperature as recommended in the de-rating graph.



# PMC Panel Mount Power Supply

## 12 V 60 W 1 Phase, NEC Class 2 / PMC-12V060W1N□

### Others

#### Conformal Coating

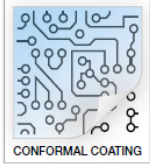

#### The Protective Coating Technology

Delta Electronics Group has designed the perfect dipping technique which penetrates everywhere including under device, and prevents leakage. The conformal coating dipping can be applied to PCBs or circuit board. The coating preserves the performance of precision electronic primarily by preventing ionizable contaminants such as salt from reaching circuit nodes, where the material slumps around sharp edges. This can be a problem especially in highly conversing atmosphere.

### Attention

Delta provides all information in the datasheets on an "AS IS" basis and does not offer any kind of warranty through the information for using the product. In the event of any discrepancy between the information in the catalog and datasheets, the datasheets shall prevail (please refer to [www.DeltaPSU.com](http://www.DeltaPSU.com) for the latest datasheets information). Delta shall have no liability of indemnification for any claim or action arising from any error for the provided information in the datasheets. Customer shall take its responsibility for evaluation of using the product before placing an order with Delta.

Delta reserves the right to make changes to the information described in the datasheets without notice.

### Manufacturer and Authorized Representatives Information

#### Manufacturer

##### Thailand

Delta Electronics (Thailand) PCL.  
909 Pattana 1 Rd., Muang, Samutprakarn, 10280 Thailand

##### Taiwan

Delta Electronics, Inc.  
3 Tungyuan Road, Chungli Industrial Zone, Taoyuan County  
32063, Taiwan

#### Authorized Representatives

##### The Netherlands

Delta Greentech (Netherlands) B.V.  
Zandsteen 15, 2132 MZ Hoofddorp, The Netherlands

##### United Kingdom

Delta Electronics Europe Limited  
1 Redwood Court, Peel Park Campus,  
East Kilbride, Glasgow, G74 5PF, United Kingdom

## X-ON Electronics

Largest Supplier of Electrical and Electronic Components

*Click to view similar products for [Switching Power Supplies](#) category:*

*Click to view products by [Delta](#) manufacturer:*

Other Similar products are found below :

[70841011](#) [73-551-0005](#) [73-551-0048](#) [PS3E-B12F](#) [PS3E-E12F](#) [AAD600S-4-OP](#) [R22095](#) [KD0204](#) [9021](#) [LDIN100150](#) [LPM000-BBAR-01](#)  
[LPX17S-C](#) [EVS57-10R6/R](#) [FP80](#) [FRV7000G](#) [22929](#) [PS3E-F12F](#) [CQM1IA121](#) [40370121900](#) [VI-PU22-EXX](#) [40370121910](#) [LDIN5075](#)  
[LPM615-CHAS](#) [LPX140-C](#) [09-160CFG](#) [70841025](#) [VPX3000-CBL-DC](#) [VI-LUL-IU](#) [LPM000-BBAR-05](#) [LPM000-BBAR-08](#) [LPM124-](#)  
[OUTA1-48](#) [LPM000-BBAR-07](#) [LPM109-OUTA1-10](#) [LPM616-CHAS](#) [08-30466-1055G](#) [08-30466-2175G](#) [08-30466-2125G](#) [DMB-EWG](#)  
[TVQF-1219-18S](#) [6504-226-2101](#) [CQM1IPS01](#) [SP-300-5](#) [CQM1-IPS02](#) [VI-MUL-ES](#) [22829](#) [08-30466-0065G](#) [VI-RU031-EWWX](#) [08-30466-](#)  
[0028G](#) [EP3000AC48INZ](#) [VP-C2104853](#)