

Full-Time Continuous Monitor Installation, Operation and Maintenance



Made in the
United States of America



Figure 1. Desco Full-Time Continuous Monitor

Description

Leading companies use continuous monitors as a cost effective component in satisfying the paragraph 6.1.3 Compliance Verification Plan requirements of ANSI/ESD S20.20. The Desco Full Time Continuous Monitor provides 100% monitoring of both the operator and the work surface. This unit provides continuous monitoring of:

- One user wearing a wrist strap
- ESD worksurface
- Ground
- AC outlet

Note: Worksurface must have a conductive layer such as Dual Layer Rubber, Dissipative 3-Layer Vinyl or Micastat® Dissipative Laminate with conductive buried layers. Desco Continuous Monitors are not recommended for use with homogeneous matting.

If the unit detects that the elements are outside industry standards, the continuous monitor will alarm with both an audible alarm and an illuminated red LED to notify the user of a problem.

Unlike many units, the Full Time Continuous Monitor also continuously verifies ground (AC outlet ground). When the Power Cord is plugged in, a self-test runs automatically. If the AC outlet is wired incorrectly, both red LEDs will illuminate and the audible alarm will sound. The unit has an additional ground point for a user or supervisor.

The Full Time Continuous Monitor is available in two models:

Item	Input Voltage	Power Cord
19325	120VAC	North America
19326	220VAC	United Kingdom

ADVANTAGES OF WORKSTATION CONTINUOUS MONITORING OVER PERIODIC TESTING

Many customers are eliminating periodic testing and are utilizing workstation continuous monitoring to better ensure that their products were manufactured in an ESD controlled environment. Full time workstation continuous monitoring is superior to pulsed monitoring as well as periodic testing, and can save a significant amount of money in testing costs and rejected products. Periodic testing detects failures after ESD susceptible products have been manufactured. The costs of dealing with the resulting catastrophic or latent defects can be considerable. Full Time Continuous Monitors eliminate the need for users to test wrist straps and log the results; by their function, these monitors satisfy the ISO 9000 and ANSI/ESD S20.20 Paragraph 6.2.2.2. test logging requirements. Per ESD-S1.1 paragraph 6.1.3 Frequency of Functional Testing "Daily (Wrist Strap) testing may be omitted if constant monitoring is used."

Per ESD Handbook TR 20.20 paragraph 5.3.2.4.4 Test Frequency "Because wrist straps have a finite life, it is important to develop a test frequency that will guarantee integrity of the system. Typical test programs recommend that wrist straps that are used daily should be tested daily. However, if the products that are being produced are of such value that knowledge of a continuous, reliable ground is needed, and then continuous monitoring should be considered or even required."

WAVE DISTORTION DETECTION TECHNOLOGY PROVIDES TRUE 100% CONTINUOUS MONITORING

Desco utilizes wave distortion technology for the Full Time Continuous Monitor, which is an Impedance type monitor.

Per ESD TR12-01 section 2.2 Impedance (or single wire) constant monitors "The capacitance type of monitor is also known as an impedance monitor. They both work on the same theory, however the impedance monitor uses a detection circuit designed to reduce false alarms and eliminate adjustments. 'Single Wire' or 'impedance type' monitors use the phase difference between current and voltage to detect changes in impedance of the cord, band and person. A very low AC voltage is used for constant sensing. Any standard wristband and coiled cord can be used."

Thus the wave distortion circuitry monitors current/voltage phase shifts and provides true 100% continuous monitoring. Electrical current will lead voltage at various points due to the combinations of resistance and capacitive reactance. By monitoring these "distortions" or phase shifts, the wave distortion Full Time Continuous Monitor will reliably determine if the circuit is complete.

Wave distortion technology can be referred to as “vector impedance monitoring”. This description is valid as the wave distortion technology measures the impedance at the monitored banana jack and looks for changes in either the capacitance or resistance of the circuit which includes the wrist strap and its wearer. It uses filtering and time domain sampling to filter out false signals caused by voltage offsets, 60 Hz fields and other electro-magnetic and electrostatic interference.

In normal factory environments, and with persons whose capacitance with respect to ground is within design limits (5 feet tall 90 pound person to 6 foot 5 inch 250 pound person), the Full Time Continuous Monitor cannot be “fooled”. It will provide a reliable alarm only when the wrist strap or work surface becomes dysfunctional or unsafe according to accepted industry standards. The Full Time Continuous Monitor is drift-free and designed to be insensitive to the effects of squeezing or stretching the coil cord.

ADVANTAGES OF WAVE DISTORTION AND SINGLE-WIRE TECHNOLOGY

The Desco Full Time Continuous Monitor allows the use of any standard, single-wire wrist strap and coil cord. The monitor / wrist strap / cord system life-cycle costs are by far lower than alternative systems which require dual-wire cords and special wrist straps. Dual-wire cords are expensive and are the weak link of the system, the most likely component to need replacement. Over a five year period, this can make the dual-wire system three to five times as expensive as a system utilizing single-wire wrist straps and cords. See Calibration section on page 4 to minimize life cycle costs.

The dictionary defines constant as uniform and unchanging, and continuous as uninterrupted. Nonetheless, some dual-wire resistance monitors utilize a pulsed test current and do not really provide continuous monitoring. For example, during each 2.2 second pulse cycle of a leading “constant” resistive monitor, electrical current is pulsed for only 0.2 seconds followed by an unmonitored interval of 2 seconds. This leaves the user/wrist strap unmonitored for over 90% of each cycle. Damaging static charges can easily occur in the portion of the time in between the pulses. The off period of 2 seconds equals 2 billion nanoseconds, and “it takes only about 25 volts applied for 100 nanoseconds to blow most memories or microprocessors”.* Some dual-wire systems do not reliably meet all industry specifications, as the cords may not meet the EOS/ESD S-1.0 paragraph 4.1.6 one to five pound “breakaway force” requirement for operator safety.

By using the reliable wave distortion technology to determine if the circuit is complete, there are no false alarms. There is no need to adjust or tune the monitor to a specific user or installation. The miniscule amount of electrical current (less than 1 volt coil cord signal) required to generate the waveform has never caused reported skin irritation and is extremely safe for use in voltage sensitive applications such as disk drive manufacturing.

Packaging

- 1 Full-Time Continuous Monitor
- 1 Power Cord
- 1 Mat Monitor Cord (Black)
- 1 Ground Cord (Green and Yellow)
- 2 Countersunk Washers
- 2 Flat Head Screws, 6-32 x 1/4"
- 1 Hook and Loop Fastener Strip
- 1 Certificate of Calibration

Features and Components

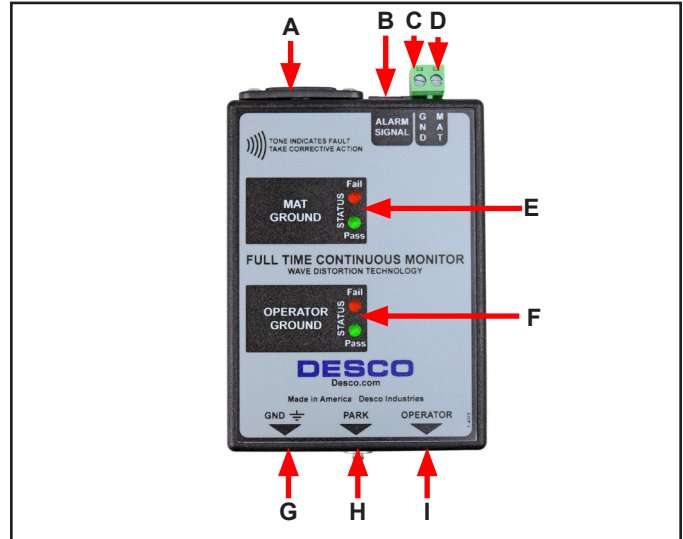

Figure 2. Full-Time Continuous Monitor features and components

- A. IEC Power Cord Inlet:** Connect the power cord here.
- B. I/O Signal Output:** Contact Desco Customer Service for more information
- C. Monitored Ground Terminal:** Grounds the worksurface mat. Connect the green and yellow ground cord here.
- D. Monitored Mat Terminal:** Monitors the worksurface mat. Connect the black mat monitor cord here.
- E. Mat Ground LEDs:** When the green LED is illuminated, the worksurface mat is properly grounded. When the red LED is illuminated and the alarm sounds, the worksurface mat is not properly grounded.
- F. Operator Ground LEDs:** When the green LED is illuminated, the operator is properly grounded. When the red LED is illuminated and the alarm sounds, the operator is not properly grounded.
- G. Auxiliary Ground:** Unmonitored banana jack ground point.

H. 4mm Parking Snap: When touched by the operator, this snap will deactivate the alarm for six seconds. This allows time for the operator to disconnect the coil cord from the wrist band and park it on this snap. While parked, the coil cord disables the alarm, allowing the operator to leave the workstation. The OPERATOR GROUND LED will remain off while the cord is parked. Upon returning and removing the coil cord from the parking snap, the operator has six seconds to hook up to the wrist band before the alarm sounds.

I. Monitored Operator Jack: Where the operator inserts the wrist cord plug.

Installation

Remove the monitor from its packaging and inspect for any shipping damage. Confirm that the worksurface is 10 megohms or less and has a conductive layer such as Dual Layer Rubber, Dissipative 3-Layer Vinyl, or Micastat® Dissipative Laminate with conductive buried layers.

1. Locate a nearby power outlet and test it for proper wiring and grounding. We recommend the [Desco AC Outlet Analyzer](#) to verify proper wiring and ground.
2. Connect the tinned wire termination of the Ground Cord to the GND terminal block on the monitor.
3. Connect the tinned wire termination of the Mat Monitor Cord to the MAT terminal block on the monitor.
4. Determine the mounting location of the Full-Time Continuous Monitor. It is normally installed toward the front edge of a workstation where its LEDs can be visible to the operator. Use the included hook and loop strip if desired.
5. Use a blade to pierce two holes 12" to 72" apart from one another into the worksurface mat.
6. Use a Phillips screwdriver to secure the two flathead screws and countersunk washers through the worksurface mat and into the threaded 10mm snaps on the underside of the Mat Monitor Cord and Ground Cord.
7. Connect the power cord to the power inlet located on the top-side of the Full-Time Continuous Monitor. Connect the opposite end of the power cord to the tested AC outlet.

NOTE: Older revision Full-Time Continuous Monitors included push and clinch snaps instead of countersunk washers and flat head screws to secure the mat monitor cord and ground cord to the worksurface mat.

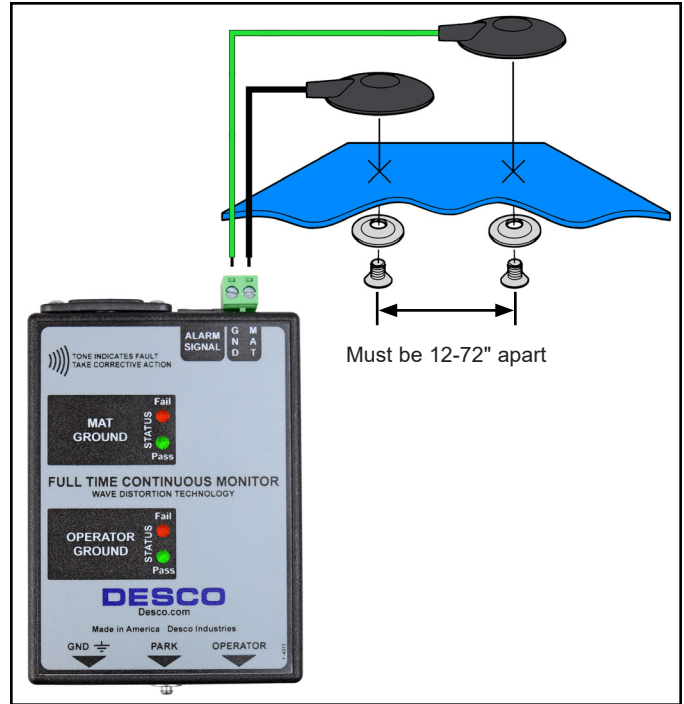

Figure 3. Wiring the Full-Time Continuous Monitor to a worksurface mat

50547 RELAY BOX



Figure 4. EMIT [50547](#) Full-Time Continuous Monitor Relay Box

The Full-Time Continuous Monitor can be equipped with the EMIT [50547](#) Relay Box to control electronic door locks, lights, buzzers, etc. The relay will activate when a failure is caught by the Full-Time Continuous Monitors.

Maximum Switching Current:
1A @ 30VDC or .3A @ 125VAC

Contact Form:
2 Form C

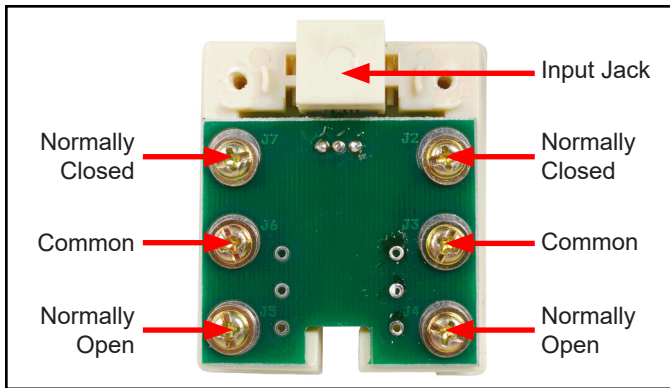

Figure 5. Full-Time Continuous Monitor Relay Box features and components

1. Remove the cover from the Relay Box.
2. Tie wire around the necessary contacts inside the Relay Box.
3. Route the wire out the bottom of the Relay Box and close the cover.
4. Make the proper connections to your targeted device (light fixture, door lock, etc.). Use Figure 6 as a guide.
5. Power the Full-Time Continuous Monitor after installation is completed.

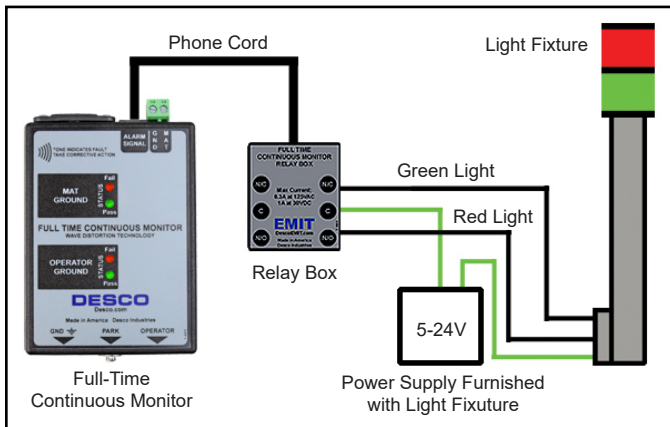

Figure 6. Installing the Relay Box and Full-Time Continuous Monitor to a Light Fixture

Operation

When the Full-Time Continuous Monitor is installed to an ESD protective worksurface and grounded via a power cord, the green MAT GROUND LED and red OPERATOR GROUND LED should illuminate. The monitor takes 6 seconds to activate its alarm circuitry when first powered.

- Correct wiring of the outlet is confirmed when the monitor is plugged in.
- The worksurface resistance is measured between the two snaps installed to the mat worksurface.

USING THE MONITOR

1. Plug a wrist strap cord, not attached to the wristband, into the monitored banana jack labeled OPERATOR on the front of the unit. This automatically activates the selected operator channel. The red operator LED should illuminate, and the audible alarm will sound after the activation period.
2. Remove the charges from your body by making contact with a properly grounded ESD worksurface. Snap the cord to the wristband, and fit it snugly onto your wrist. This should silence the audible alarm and cause the OPERATOR GROUND LED to switch from red to green. If this does not happen, examine the wrist cord for continuity or damage and your wrist band to ensure that it is securely fit. If you have dry skin, apply an approved dissipative hand lotion such as [Menda Reztore™ ESD Hand Lotion](#). When leaving the area, the user can take the wrist cord along or attach it to the monitor parking snap. The audible alarm will shut off when operator wrist cord is removed from unit and or when the cord is attached to the parking snap.

NOTE: Removing the banana plug from the monitor's operator jack will disable the audible alarm.

PARKING SNAP

All Desco single-wire monitors with wave distortion technology include the Park Snap feature. Use the Park Snap to store the operator's wrist cord and enable standby mode while the operator is away from the workstation. Before disconnecting the coil cord from the wristband, the operator touches the Park Snap to disable the audio alarm for 6 seconds. Within the 6 second period, the operator can disconnect their wrist cord from their wristband and attach it to the Park Snap before the audible alarm sounds.

WORKSURFACE CHANNEL

The Full Time Continuous Monitor's circuitry is sufficiently sensitive to detect extremely low current when used with a worksurface with a conductive layer.

Note: The monitor will not detect insulative contamination on the worksurface. "Insulative contamination can increase the resistance to ground making the worksurface ineffective." (ESD TR12-01 section 3.1 Worksurface monitors). ESD worksurfaces should be kept clean using an approved ESD cleaner like Reztore™ Antistatic Surface & Mat Cleaner. When the monitor is connected to an ESD worksurface, the amount of current that flows is a function of the total resistance between the Continuous Monitor and through the worksurface to ground. When the resistance of the worksurface is below a pre-set threshold, the monitor will indicate Pass. Conversely, if the resistance level is high when compared to the monitor's reference, the unit will fail and alarm. This is an integrating resistance measuring circuit, therefore it is relatively insensitive to externally induced electromagnetic fields. The resistance threshold is factory set to 10 megohms. (It can be special ordered to other limits. Contact manufacturer for specifications).

Calibration

Frequency of recalibration should be based on the critical nature of those ESD sensitive items handled and the risk of failure for the ESD protective equipment and materials. In general, Desco recommends that calibration be performed annually.

Use the Desco [98221](#) Wave Distortion Monitor Verification Tester to perform periodic verification (once every 6-12 months) of the Full-Time Continuous Monitor. The verification tester can be used to check the test limits of the Full-Time Continuous Monitor without removing it from the workstation.

See [TB-3074](#) for more information.



Figure 7. Desco [98221](#) Wave Distortion Monitor Verification Tester

Specifications

Input Voltage and Frequency	100-120VAC, 50/60 Hz
Operating Temperature	50 to 95°F (10 to 35°C)
Environmental Requirements	Indoor use only at altitudes less than 6500 ft. (2 km) Maximum relative humidity of 80% up to 85°F (30°C) decreasing linearly to 50% @ 85°F (30°C)
Dimensions	4.38" L x 3.25" W x 0.89" H (111 mm x 83 mm x 23 mm)
Weight	0.26 lbs. (0.12 kg)
Operator Test Range*	500 kilohms to 10 megohms impedance
Worksurface Test Limit**	10 megohms (±20%)
Operator Test Voltage	1.2V peak-to-peak @ 1.2μA, open circuit
Worksurface Test Voltage	5 to 7.5V, open circuit
Alarm Response Time	<50 ms
Country of Origin	United States of America

*This cannot be verified with standard DC test equipment. The continuous monitor is an impedance sensing device, and the limits are determined by the magnitude and angle of the impedance.

**The worksurface mat must have a conductive layer such as Dual Layer Rubber or Dissipative 3-Layer Vinyl with conductive buried layers. Desco workstation monitors are not recommended for use with homogeneous matting.

Limited Warranty, Warranty Exclusions, Limit of Liability and RMA Request Instructions

See the Desco Warranty - [Desco.com/Limited-Warranty.aspx](https://www.desco.com/Limited-Warranty.aspx)

X-ON Electronics

Largest Supplier of Electrical and Electronic Components

Click to view similar products for [AntiStatic Control Products](#) category:

Click to view products by [Desco](#) manufacturer:

Other Similar products are found below :

[13505](#) [13870](#) [14404](#) [20-053-0017](#) [2229](#) [2231](#) [3039](#) [37061](#) [39792](#) [42470](#) [XON-ASB4X30](#) [XON-ASB4X6](#) [XON-ASB6X30](#) [09813](#) [09857](#)
[XON-ASB8X10](#) [XON-ASB6X10](#) [19695](#) [09037](#) [68101](#) [68103](#) [73741](#) [13515](#) [13869](#) [13868](#) [13485](#) [13457](#) [13245](#) [13332](#) [13205](#) [13135](#) [91070](#)
[8031](#) [8523](#) [13080](#) [13215](#) [157 ROLL BEIGE 1.0](#) [VERAX1R-300R](#) [17260](#) [66051](#) [12550](#) [19863](#) [09121](#) [73831](#) [13340](#) [13338](#) [04541](#) [19696](#)
[16104](#) [SPI-20686](#)