

# Dual Combination Tester Installation, Operation and Maintenance



Made in the  
United States of America

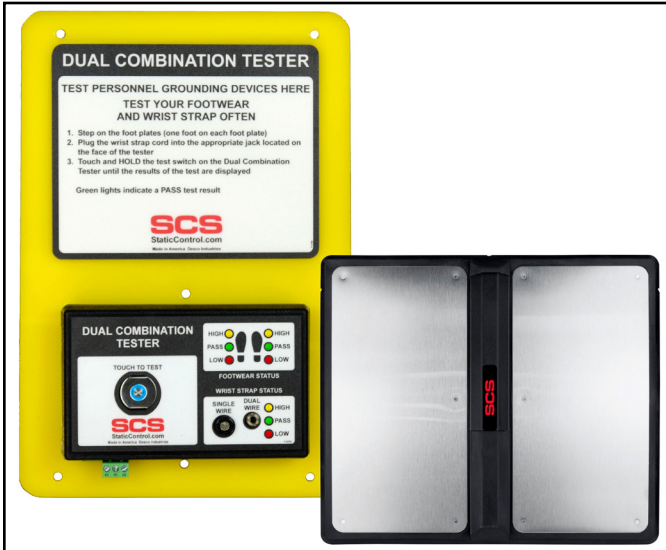

Figure 1. SCS 770758 Dual Combination Tester and Dual Foot Plate

## Description

The SCS Dual Combination Tester verifies the functionality of personnel grounding devices (wrist straps<sup>1</sup>, foot grounders, ESD shoes, smocks<sup>2</sup>). Three independent tests are performed simultaneously on the wrist strap and each foot. Green lights indicate a pass condition. Red and yellow lights plus an audible alarm indicate when the wrist strap and/or footwear (left or right) have failed. DIP switches may be accessed for test limit preferences. Access control to an ESD Protected Area can be further enforced by using the relay terminal on the Dual Combination Tester and connecting it to an electronic door lock or turnstile to grant access only to those who have passed their personal grounding device tests. The Dual Combination Tester is calibrated to NIST standards and includes a certificate.

### SCS Dual Combination Tester Technology

- The solid-state touch test switch maintains test accuracy and extends the lifetime of the tester
- The 30 volt test signal increases test reliability

The factory test limits are set to:

Wrist Straps: 750 kilohms and 10 megohms  
Footwear: 750 kilohms and 35 megohms

(See page 3 for alternate test limit settings)

The Dual Combination Tester and its accessories are available as the following item numbers:

Item	Description
<a href="#">770758</a>	Dual Combination Tester
<a href="#">770759</a>	Stand, for Dual Combination Tester
<a href="#">770751</a>	Limit Comparator
<a href="#">770752</a>	Power Adapter, 100-240 VAC Input, 12 VDC 0.5 A Output, All Plugs

Per ANSI/ESD S20.20 section 7.3 “A Compliance Verification Plan shall be established to ensure the Organization’s fulfillment of the technical requirements of the ESD Control Program Plan. Process monitoring (measurements) shall be conducted in accordance with a Compliance Verification Plan that identifies the technical requirements to be verified, the measurement limits and the frequency at which those verifications shall occur. The Compliance Verification Plan shall document the test methods and equipment used for process monitoring and measurements. ... The test equipment selected shall be capable of making the measurements defined in the Compliance Verification Plan.”

Per ANSI/ESD S1.1 Annex A.3 Frequency of System Testing “The wrist strap system should be tested daily to ensure proper electrical resistance.”

“Compliance verification should be performed prior to each use (daily, shift change, etc.). The accumulation of insulative materials may increase the foot grounder system resistance. If foot grounders are worn outside the ESD protected area testing for functionality before reentry to the ESD protected area should be considered.” (ESD SP9.2 APPENDIX B - Foot Grounder Usage Guidance)

1. The Dual Combination Tester can verify single-wire and dual-wire wrist straps.
2. The Dual Combination Tester will also test a Groundable Static Control Garment System. The Groundable Static Control Garment System must have an RTG of  $< 3.5 \times 10^7$  ohms to meet the required limit of ANSI/ESD S20.20 tested per ANSI/ESD STM2.1 and ESD TR53.

## Packaging

### 770758 DUAL COMBINATION TESTER

- 1 Dual Combination Tester
- 1 Dual Foot Plate
- 1 Power Adapter, 12 VDC, with interchangeable plugs (North America, UK/Asia, Europe)
- 1 Foot Plate Cord, 6'
- 1 Ground Cord
- 1 Certificate of Calibration

### 770759 STAND, FOR DUAL COMBINATION TESTER

- 1 Pedestal (Two-Pieces)
- 1 Base Plate
- 5 Socket Head Screws, 1/4-20 x 1/2"
- 2 Phillips Head Screws, 10-32 x 5/8"
- 2 Nuts, 10-32
- 2 Spacers

## Features and Components

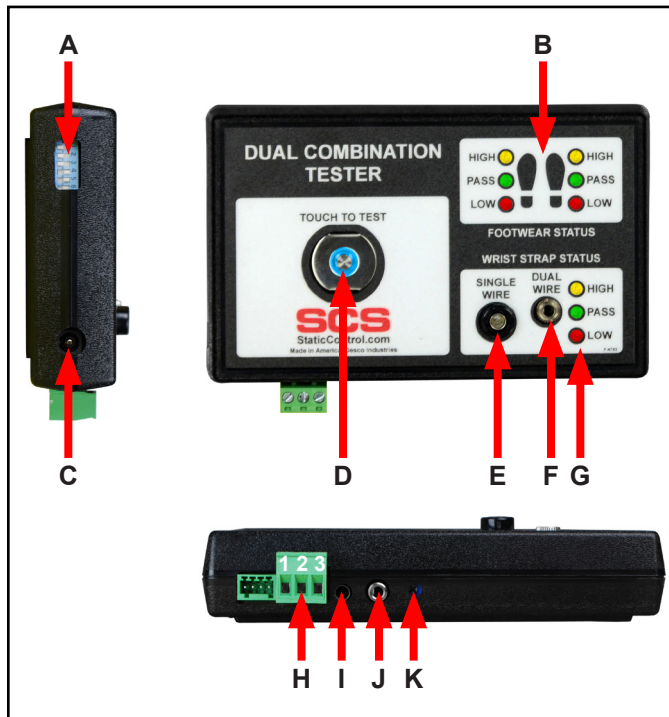

Figure 2. Dual Combination Tester features and components

**A. Test Limit DIP Switch:** Use this DIP switch to configure the resistance limits of the tester. See the section titled "Tester Configuration" for more information.

**B. Footwear Status LEDs:** Displays the footwear test results.

**C. 12VDC Power Jack:** Connect the included power adapter here to power the Dual Combination Tester.

**D. Steady-State Test Switch:** Place and hold your finger here to begin the test.

**E. Single-Wire Wrist Strap Jack:** Insert your single-wire wrist cord here to test your wrist strap.

**F. Dual-Wire Wrist Strap Jack:** Insert your dual-wire wrist cord here to test your wrist strap.

**G. Wrist Strap Status LEDs:** Displays the wrist strap test results.

**H. Relay Terminal:** Can be integrated with electronic door locks, lights, buzzers, etc. It is capable of switching up to 1 A @ 30 VDC or .5 A @ 125 VAC.

Terminals 1 & 2 = Normally Closed  
Terminals 2 & 3 = Normally Open

**NOTE:** All tests must pass in order for the relay to activate. The relay timer lasts approximately 2.5 seconds and cannot be modified. The timer starts once the finger is removed from the test switch.

**I. Ground Jack:** Insert the banana plug end of the included ground cord to this jack. Connect the ring terminal end of the cord to equipment ground. This connection will remove any static charge from the user before the test. **NOTE: Failure to correctly ground the Dual Combination Tester may result in damage not covered under warranty.**

**J. Foot Plate Jack:** Connect one end of the foot plate cable cord and the other end to the dual foot plate.

**K. Buzzer Volume Adjustment:** Turn the trimpot clockwise to increase the buzzer volume and counter-clockwise to decrease the volume.

# Installation

## TESTER CONFIGURATION

The resistance limits for footwear and wrist strap tests are controlled by the DIP switches located on the left side of the Dual Combination Tester. Use the following tables for the DIP switch settings and their corresponding test values.

### Footwear Resistance

DIP switches 1 and 2 control the HIGH test limit.

Switch 1	Switch 2	HIGH Limit Resistance
ON	ON	10 Megohms ( $1 \times 10^7$ )
OFF	OFF	35 Megohms ( $3.5 \times 10^7$ )
ON	OFF	100 Megohms ( $1 \times 10^8$ )
OFF	ON	1 Gigohm ( $1 \times 10^9$ )

DIP switches 3 and 4 control the LOW test limit.

Switch 3	Switch 4	LOW Limit Resistance
OFF	OFF	footwear test disabled
ON	OFF	100 Kilohms ( $1 \times 10^5$ )
OFF	ON	750 Kilohms ( $7.5 \times 10^5$ )

default setting

NOTE: At 1 Gigohm high limit resistance, a dirty foot plate could result in a false pass. Be sure to keep the foot plate clean particularly when using this setting. This setting is not suitable for relative humidity greater than 50 %.

### Wrist Strap Resistance

DIP switches 5 and 6 control the HIGH test limit.

Switch 5	Switch 6	HIGH Limit Resistance
OFF	OFF	wrist strap test disabled
ON	ON	10 Megohms ( $1 \times 10^7$ )
ON	OFF	35 Megohms ( $3.5 \times 10^7$ )

default setting

DIP switch 5 must be ON (default setting) for the wrist strap test to be active. The wrist strap test will be disabled if DIP switch 5 is set to OFF.

The LOW limit for the wrist strap test is set to 750 kilohms and cannot be modified by the user.

## INSTALLING THE DUAL COMBINATION TESTER

1. Mount the tester at the desired location using the four mounting holes located in the corners of the yellow mounting plate.
2. Set the dual foot plate below the tester.
3. Insert one end of the foot plate cord into the stereo jack located at the bottom of the tester. Insert the opposite end of the cord into the stereo jack located on the underside of the dual foot plate.
4. Use the guides located on the underside of the dual foot plate to route the cord either out the top or the side. This will prevent the foot plate cord from being accidentally tripped and unplugged.



Figure 3. Routing the foot plate cord through the top



Figure 4. Routing the foot plate cord through the side

5. Insert the ground cord's banana plug into the ground jack located at the bottom of the tester. Connect ground cord's ring terminal to equipment ground. This connection will remove any static charge from the user before the test. **NOTE: Failure to correctly ground the Dual Combination Tester may result in damage not covered under warranty.**
6. Power the Dual Combination Tester with the power adapter.

## INSTALLING THE DUAL COMBINATION TESTER AND STAND

1. Assemble the pedestal and base plate using the 5 socket head screws.

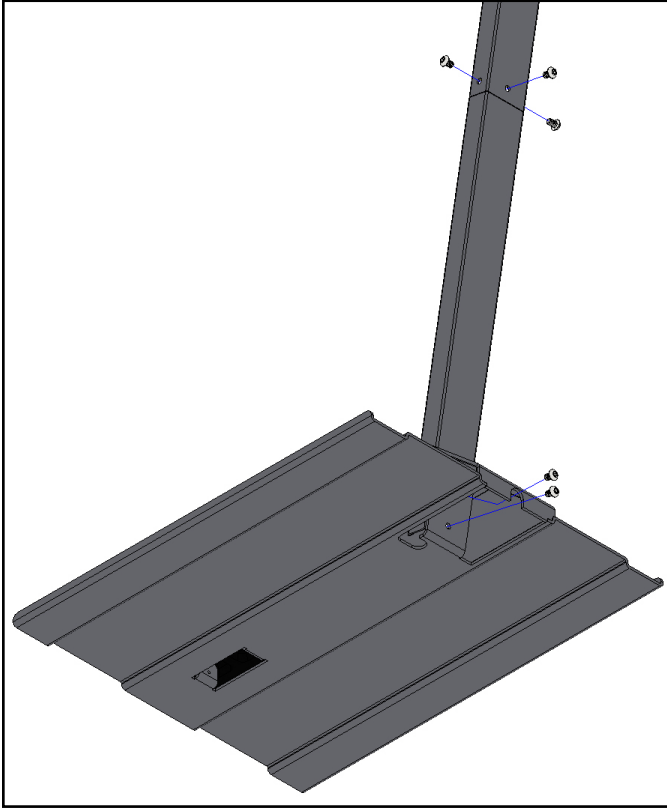

Figure 5. Assembling the pedestal and base plate using the 5 socket head screws

2. Route the ground cord, foot plate cord, and power adapter through the pedestal. Feed the cords from the bottom and have them exit through the top.
3. Align the backplate's two holes located above and below the tester to the two holes on the pedestal's mounting bracket. Secure the backplate using the two Phillips head screws, spacers, and nuts.



Figure 6. Securing the Dual Combination Tester to the pedestal

4. Plug the ground cord into the ground jack located on the bottom of the tester, and connect the ring terminal to equipment ground. This connection will remove any static charge from the user before the test. **NOTE: Failure to correctly ground the Dual Combination Tester may result in damage not covered under warranty.**
5. Plug the foot plate cord into the tester and the dual foot plate.



Figure 7. Connecting the cords to the Combo Tester X3

6. Lay the dual foot plate onto the base plate.

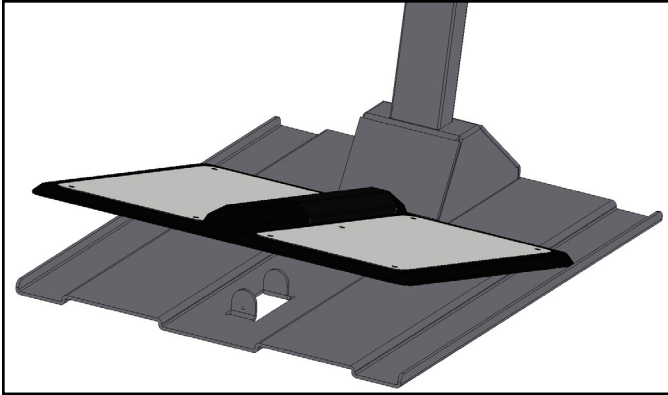

Figure 8. Installing the dual foot plate onto the baseplate

7. Power the Dual Combination Tester with the power adapter.

### WIRING THE DUAL COMBINATION TESTER TO AN ACCESS CONTROL SYSTEM

The Dual Combination Tester may be connected to an Access Control System to grant access when both a valid proximity badge is read and PASS test results are achieved at the tester. Figure 8 shows an example when using a turnstile.

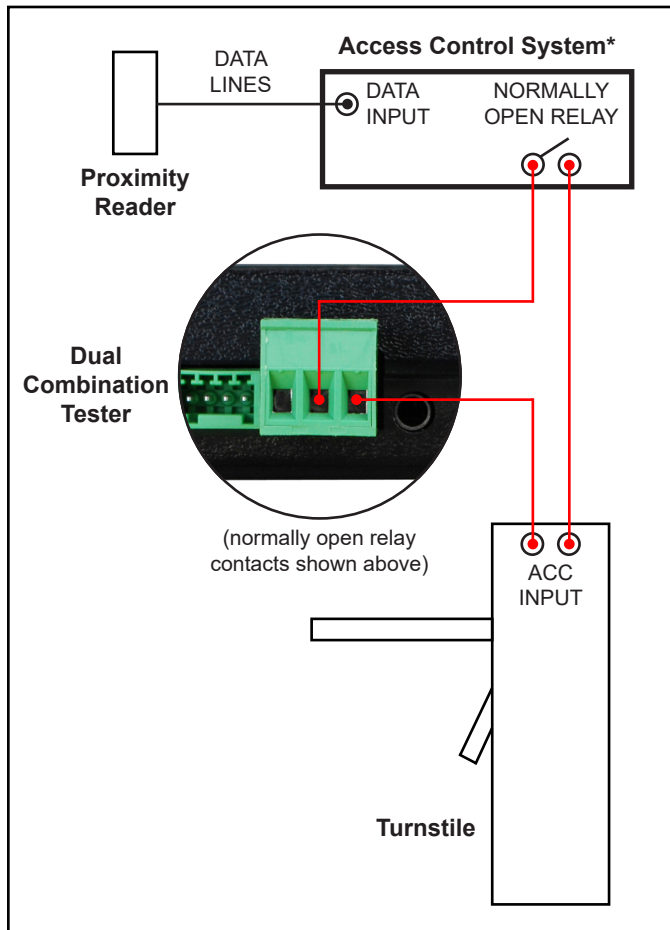

Figure 9. Wiring the Dual Combination Tester to an Access Control System

\*NOTE: The Access Control System must have a time delay feature in order to achieve the configuration described above. Set the Access Control System's relay to remain active for a few seconds when a valid proximity badge is accepted. The relay will need to remain active long enough for an operator to perform a test on the Dual Combination Tester. The access control device will only unlock when it receives an active signal from both the Access Control System and Dual Combination Tester.

### Operation

1. A circling light around the test switch indicates when the Dual Combination Tester is on standby and ready to perform a test.

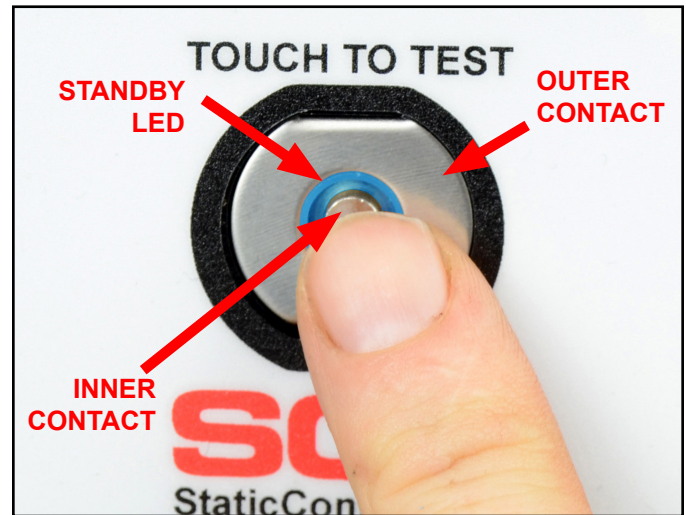

Figure 10. Steady-State Test Switch features and components

2. While wearing a wrist strap and/or ESD footwear, plug the wrist cord into its corresponding jack located on the face of the Dual Combination Tester. Place one foot on each foot plate.
3. To begin the test, use your finger to bridge the test switch's inner and outer contacts. The blue standby LED will become solid to indicate that the test has been initiated. Hold your finger down until the test results are displayed.

If your finger is removed too early, the tester's LEDs will blink three times to indicate that the test was not completed. DO NOT touch any other metal while performing your test as this will affect your results.



Figure 11. Bridging the test switch's contacts to initiate the test

4. A "PASS" test result is indicated by illumination of the green LEDs. A "FAIL LOW" test result is indicated by illumination of the red LEDs. A "FAIL HIGH" test result is indicated by illumination of the yellow LEDs.

If your ESD test fails, check your wrist strap and footwear to ensure that they are being worn correctly and/or need to be replaced.

NOTE: Failures may be caused by dry skin or minimal sweat layer. For wrist straps, try using an approved dissipative hand lotion such as [Menda Reztore™ ESD Hand Lotion](#) to your wrist prior to use. Footwear test results can be improved by taking a short walk to build a sweat layer for better conductivity.

The Dual Combination Tester may also be used to test smocks or garments that feature a grounding mechanism for operators using a coiled cord connection.



Figure 12. Using the Dual Combination Tester



Figure 13. Using the Dual Combination Tester with the 770759 Stand

## Maintenance

To maintain optimum performance, cleaning should be performed on a regular basis. Use a minimum of 80 % Isopropyl alcohol to clean the foot plate and test switch. Other cleaners are susceptible to leaving residue on these surfaces.

## Calibration

The Dual Combination Tester is calibrated to standards traceable to NIST. Frequency of recalibration should be based on the critical nature of those ESD sensitive items handled and the risk of failure for the ESD protective equipment and materials. In general, we recommend that calibration be performed annually.

The accuracy of the Dual Combination Tester is specified as:

- ±20 % for 1 gigohm footwear test limit
- ±10 % for all other test limits

A periodic check using a precision resistance box can be used to verify proper operation.

The SCS [770751](#) Limit Comparator is available for the convenient calibration of the Dual Combination Tester.

The Limit Comparator allows the customer to perform NIST traceable calibration on the Dual Combination Tester. The Limit Comparator can be used on the shop floor within a few minutes, virtually eliminating downtime, verifying that the Dual Combination Tester is operating within tolerances.

See [TB-9070](#) for more information.



Figure 14. SCS 770751 Limit Comparator

## Specifications

### Dual Combination Tester

Input Voltage and Frequency (External Adapter)	AC/DC Power Adapter Power Input: 100-240 VAC, 50/60 Hz  Power Output: 12 VDC, 0.5 A  Cable Length: 6 ft. (1.83 m)
Operating Temperature	70 to 85 °F (21 to 30 °C) for 1 gigohm test limit  41 to 85 °F (5 to 30 °C) for all other test limits
Environmental Requirements	Indoor use only at altitudes less than 6500 ft. (2 km)  Maximum relative humidity of 80 % up to 85 °F (30 °C) decreasing linearly to 50 % @ 85 °F (30 °C)  Maximum relative humidity of 50 % at 1 gigohm setting
Dimensions (with mounting plate)	11.35" x 7.75" x 1.47" (288 mm x 197 mm x 37 mm)
Weight (with mounting plate)	1.2 lbs (0.5 kg)
Test Accuracy	±20 % for 1 gigohm footwear test limit  ±10 % for all other test limits
Test Switch Voltage	5 VDC @ open circuit
Wrist Strap and Footwear Test Voltage	30 VDC @ open circuit  Test current is limited by resistors and varies on the test range setting (100 kilohms - 1 gigohm)
Relay Contact Rating	1 A @ 30 VDC max

### Dual Foot Plate

Dimensions	13.25" x 15.25" x 1.125" (337 mm x 387 mm x 29 mm)
Weight	5.5 lbs (2.5 kg)

### Limited Warranty, Warranty Exclusions, Limit of Liability and RMA Request Instructions

See the SCS Warranty - [StaticControl.com/Limited-Warranty.aspx](http://StaticControl.com/Limited-Warranty.aspx)



## X-ON Electronics

Largest Supplier of Electrical and Electronic Components

*Click to view similar products for [Antistatic Control Products](#) category:*

*Click to view products by [Desco](#) manufacturer:*

Other Similar products are found below :

[13020](#) [13490](#) [13870](#) [13879](#) [13881](#) [13883](#) [13882](#) [14404](#) [2202SP](#) [3039](#) [37061](#) [42470](#) [09060](#) [09857](#) [42516](#) [37059](#) [04563](#) [17252](#) [19691](#)  
[19695](#) [09037](#) [09826](#) [09813](#) [66070](#) [100816](#) [68101](#) [68103](#) [98132](#) [73741](#) [13868](#) [13485](#) [13457](#) [13245](#) [13468](#) [13420](#) [13332](#) [13205](#) [13135](#)  
[91070](#) [8031](#) [8523](#) [66085](#) [40931](#) [37081](#) [13080](#) [13215](#) [13806](#) [73749](#) [010-0225](#) [17260](#)