



Offline Current Mode PWM Controller with BOP and Output OVP

FEATURES

- Support DCM and CCM Operation
- $\pm 1\%$ CV Regulation
- Less than 75mW Standby Power
- Fixed 65KHz Switching Frequency
- Green Mode and Burst Mode Control
- Very Low Startup and Operation Current
- Built-in Frequency Shuffling to Reduce EMI
- Built-in Current Mode Control with Internal Slope Compensation
- Built-in Protections with Auto Recovery:
 - VDD Under Voltage Lockout (UVLO)
 - VDD Over Voltage Protection (OVP)
 - Input Brownout Protection (Brownout)
 - Output Over Voltage Protection (OVP)
 - On-Chip Thermal Shutdown (OTP)
 - Cycle-by-Cycle Current Limiting
 - Over Load Protection (OLP)
 - Leading Edge Blanking (LEB)
 - CS Pin Float Protection
- Available with SOT23-6L Package

GENERAL DESCRIPTION

DP2293 is a high performance current mode PWM controller for offline flyback converter applications. It supports DCM and CCM operation.

In DP2293, PWM switching frequency with shuffling is fixed to 65 KHz and is trimmed to tight range. The IC has built-in green and burst mode control for light and no load condition, which meet 6th energy star requirement and achieve less than 75mW standby power.

DP2293 integrates functions and protections of Under Voltage Lockout (UVLO), VDD over Voltage Protection (VDD OVP), Input Brownout Protection (Brownout), Programmable Output Over Voltage Protection (OVP), On-Chip Thermal Shutdown (OTP), Cycle-by-cycle Current Limiting (OCP), Over Load Protection (OLP), Soft Start, VDD clamping and CS Pin Float Protection, etc.

APPLICATIONS

- Chargers and Adapter
- Motor Driver Power Supply

TYPICAL APPLICATION CIRCUIT

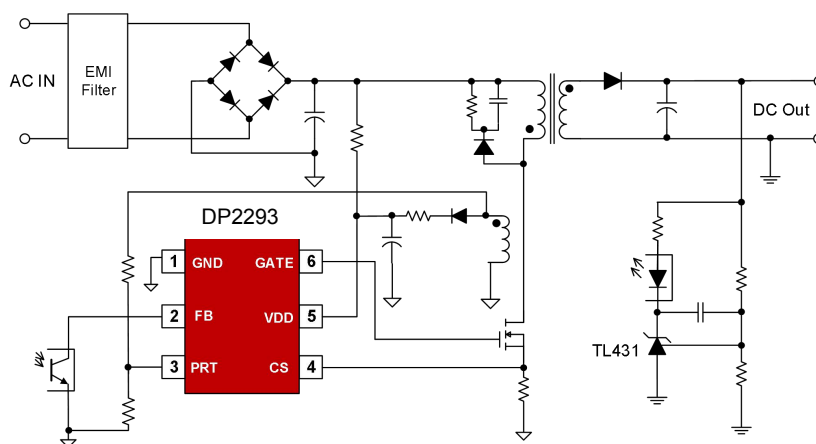



Pin Configuration

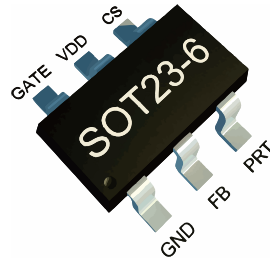

SOT23-6L

Marking Information

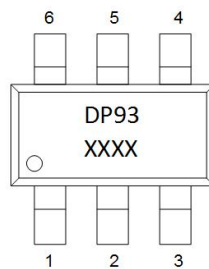

SOT23-6L

DP93 for product name;

XXXX The first X represents the last year, 2018 is 8; The second X represents the month, in A-L 12 letters; The third and fourth X on behalf of the date, 01-31 said

Pin Description

Pin Number	Pin Name	I/O	Description
1	GND	P	The ground of the IC
2	FB	I	Feedback pin. The loop regulation is achieved by connecting a photo-coupler to this pin. PWM duty cycle is determined by FB voltage and the current sense signal at Pin 4
3	PRT	I	Voltage sense for Brownout and OVP
4	CS	I	Current sense input pin
5	VDD	P	IC power supply pin
6	GATE	O	Totem-pole gate driver output to drive the external MOSFET



Ordering Information

Part Number	Description
DP2293	SOT23-6L, Halogen free, in T&R,3000Pcs/Reel

Block Diagram

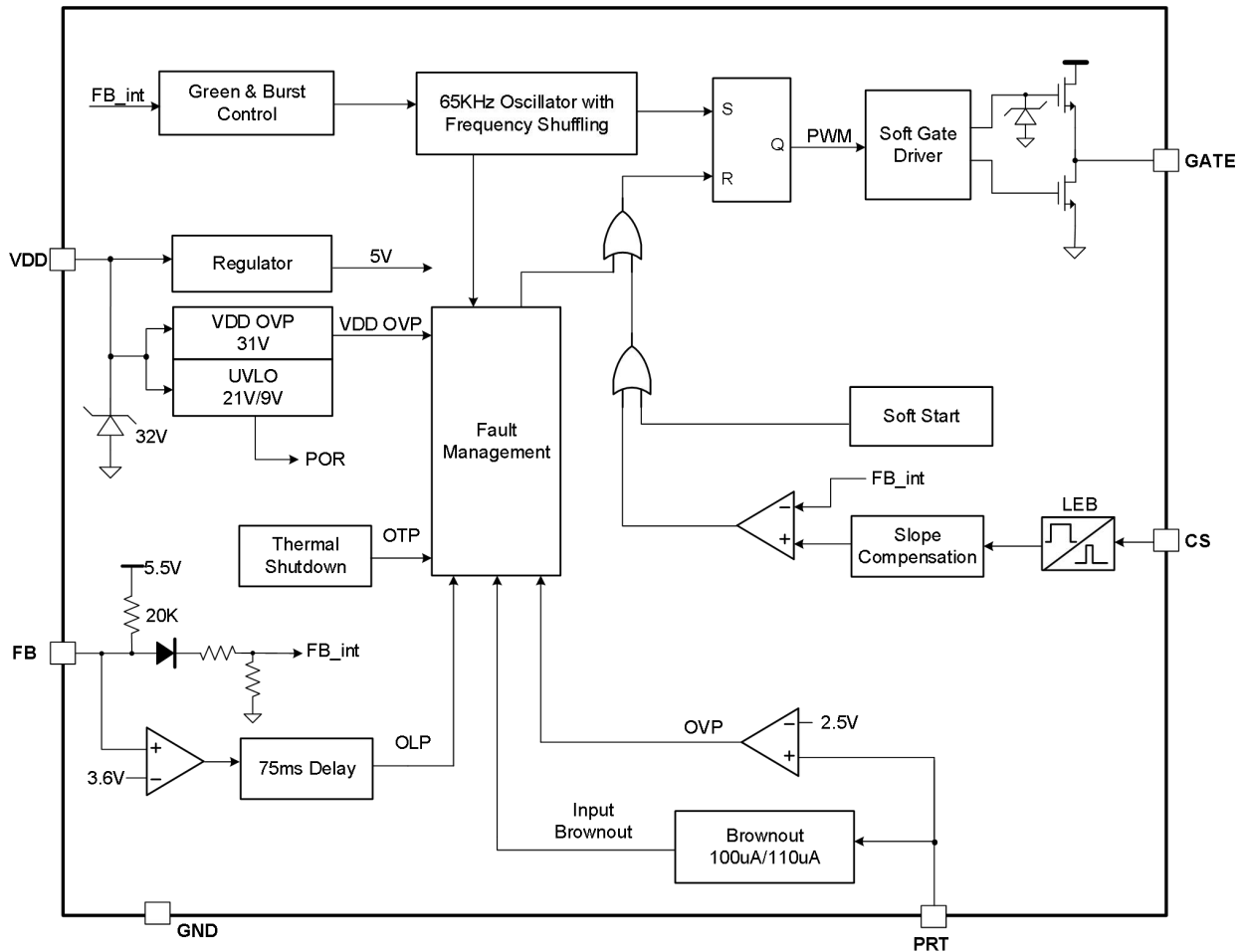



Absolute Maximum Ratings (Note 1)

Parameter	Value	Unit
VDD DC Supply Voltage	33	V
VDD DC Clamp Current	10	mA
FB, CS, PRT voltage range	-0.3 to 7	V
GATE voltage range	20	V
Package Thermal Resistance---Junction to Ambient (SOT23-6L)	250	°C/W
Maximum Junction Temperature	175	°C
Storage Temperature Range	-65 to 150	°C
Lead Temperature (Soldering, 10sec.)	260	°C
ESD Capability, HBM (Human Body Model)	3	kV
ESD Capability, MM (Machine Model)	250	V

Recommended Operation Conditions (Note 2)

Parameter	Value	Unit
Supply Voltage, VDD	10 to 28	V
Operating Ambient Temperature	-40 to 85	°C

Electrical Characteristics (TA= 25°C, VDD=18V, if not otherwise noted)

Symbol	Parameter	Test Conditions	Min	Typ.	Max	Unit
Supply Voltage Section (VDD Pin)						
I _{VDD_st}	Start-up current into VDD pin			2	20	uA
I _{VDD_Op}	Operation Current	V _{FB} =3V, GATE=1nF		1.2	2	mA
I _{VDD_standby}	Standby Current			0.6	1	mA
V _{DD_ON}	VDD Under Voltage Lockout Exit		19	21	21.5	V
V _{DD_OFF}	VDD Under Voltage Lockout Enter		8	9	10	V
V _{DD_OVP}	VDD OVP Threshold		29	31	33	V
V _{DD_Clamp}	VDD Zener Clamp Voltage	I(V _{DD}) = 7 mA	33	35	37	V
Feedback Input Section (FB Pin)						
V _{FB_Open}	FB Open Voltage			5.5		V



DP2293

Offline Current Mode PWM Controller with BOP and Output OVP

I_{FB_Short}	FB Short Circuit Current	Short FB Pin to GND, Measure Current		0.3		mA
Z_{FB_IN}	FB Input Impedance			20		K Ω
A_{CS}	PWM Gain	$\Delta V_{FB} / \Delta V_{CS}$		2.0		V/V
V_{skip}	FB Under Voltage GATE Clock is OFF			1.0		V
V_{TH_OLP}	Power Limiting FB Threshold Voltage			3.6		V
T_{D_OLP}	Power Limiting Debounce Time			75		ms
Current Sense Input Section (CS Pin)						
T_{LEB}	CS Input Leading Edge Blanking Time			300		ns
V_{CS_max}	Cycle-by-cycle Current limiting threshold		0.97	1.0	1.03	V
T_{D_OC}	Over Current Detection and Control Delay	GATE=1nF		70		ns
Oscillator Section						
F_{OSC}	Normal Oscillation Frequency		60	65	70	KHz
$\Delta F(\text{shuffle}) / F_{OSC}$	Frequency Shuffling Range		-4		4	%
$T(\text{shuffle})$	Frequency Shuffling Period			32		ms
D_{MAX}	Maximum Switching Duty Cycle			66.7		%
F_{Bust}	Burst Mode Base Frequency			22		KHz
Brownout and OVP Section (PRT Pin)						
V_{OVP}	Over Voltage Protection Threshold			2.5		V
$I_{Brownout_Tr}$	Brownout Trigger Current			100		μ A
$I_{Brownout_Re}$	Brownout Recovery Current			110		μ A
On-Chip Thermal Shutdown						
T_{SD}	Thermal Shutdown	(Note 3)		165		$^{\circ}$ C
T_{RC}	Thermal Recovery	(Note 3)		140		$^{\circ}$ C
DriverSection (GATE Pin) (Note 3)						
V_{OL}	Output Low Level	Igate_sink=20mA			1	V
V_{OH}	Output High Level	Igate_source=20mA	7.5			V
V_{G_Clamp}	Output Clamp Voltage Level	VDD=24V		13		V
T_r	Output Rising Time	GATE=1nF		150		ns
T_f	Output Falling Time	GATE=1nF		60		ns



DP2293

Offline Current Mode PWM Controller with BOP and Output OVP

Note1. Stresses listed as the above "Maximum Ratings "may cause permanent damage to the device. These are for stress ratings. Functional operation of the device at these or any other conditions beyond those indicated in the operational sections of the specifications is not implied. Exposure to maximum rating conditions for extended periods may remain possibility to affect device reliability.

Note2. The device is not guaranteed to function outside its operating conditions.

Note3. Guaranteed by the Design.



Characterization Plots

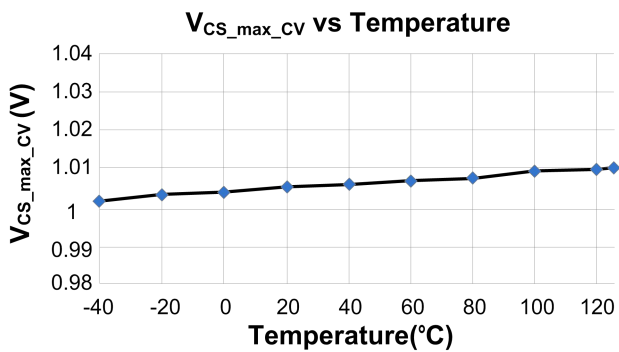
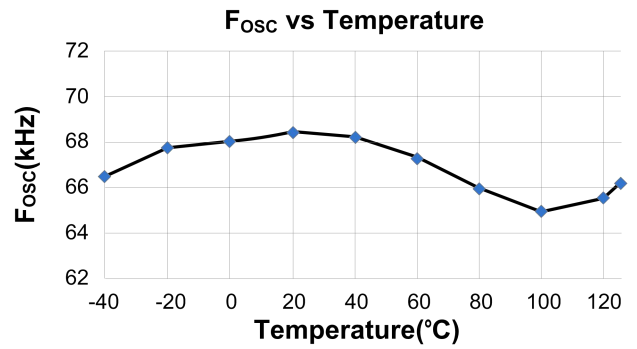
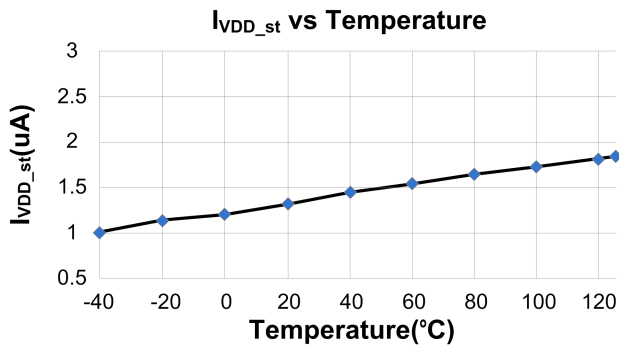
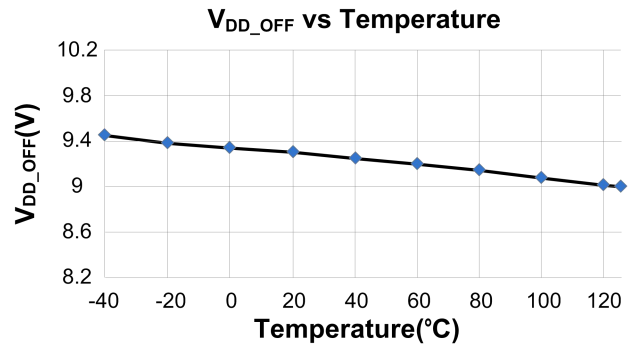
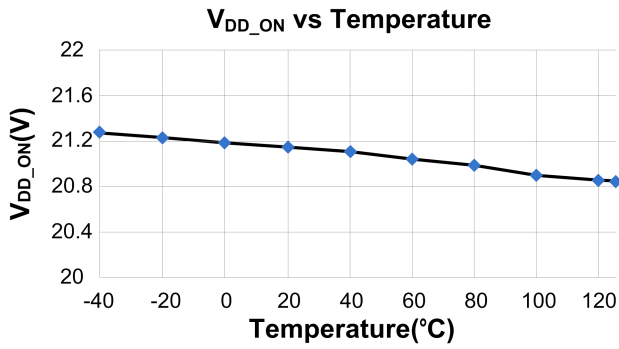



Operation Description

DP2293 is a high performance current mode PWM controller for offline flyback charger, motor driver power supply and adapter applications. The IC can support CCM and DCM operation, which is suitable for isolated power supply design that requires CV regulation of the output.

- **System Start-Up Operation and IC Operation Current**

Before the IC starts to work, it consumes only startup current (typically 2uA) which allows a large value startup resistor to be used to minimize the power loss and the current flowing through the startup resistor charges the VDD hold-up capacitor from the high voltage DC bus. When VDD reaches turn on threshold V_{DD_ON} (typical 21V), DP2293 begins switching and the IC operation current is increased to be 1.2mA (typical). The hold-up capacitor continues to supply VDD before the auxiliary winding of the transformer takes the control of VDD voltage.

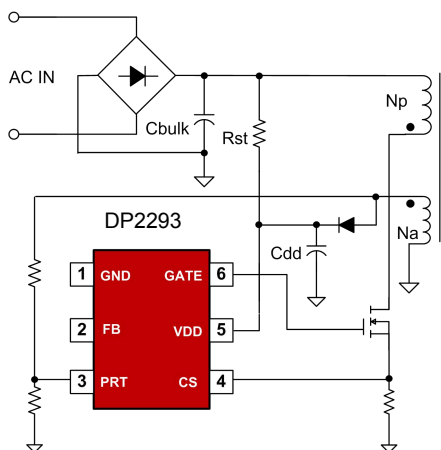

Fig.1

- **Oscillator with Frequency Shuffling**

PWM switching frequency in DP2293 is fixed to 65KHz and is trimmed to tight range. To improve system EMI performance, DP2293 operates the system with 4% frequency shuffling around setting frequency.

- **Green Mode Operation**

Since the main power dissipation at light/zero load in a switching mode power supply is from the switching loss which is proportional to the PWM switching frequency. To meet green mode requirement, it is necessary to reduce the switching cycles under such conditions either by skipping some switching pulses or by reducing the switching frequency.

Smooth Frequency Foldback

In DP2293, a Proprietary “Smooth Frequency Foldback” function is integrated to foldback the PWM switching frequency when the loading is light. Compared to the other frequency reduction implementations, this technique can reduce the PWM frequency smoothly without audible noise.

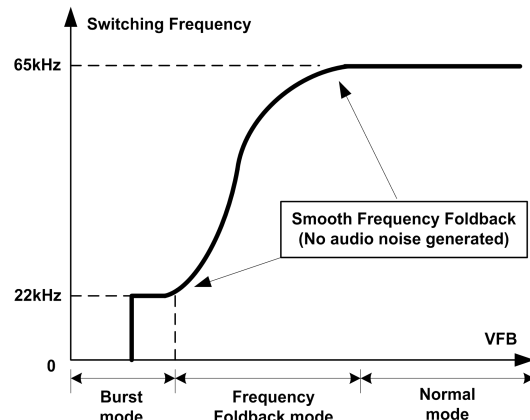

Fig.2

Burst Mode Control

When the loading is very small, the system enters burst mode. When VFB drops below V_{skip} , DP2293 will stop switching and output voltage starts to drop (as shown in Fig.3), which causes the VFB to rise. Once VFB rises above V_{skip} , switching resumes. Burst mode control alternately enables and disables switching, thereby reducing switching loss in standby mode.

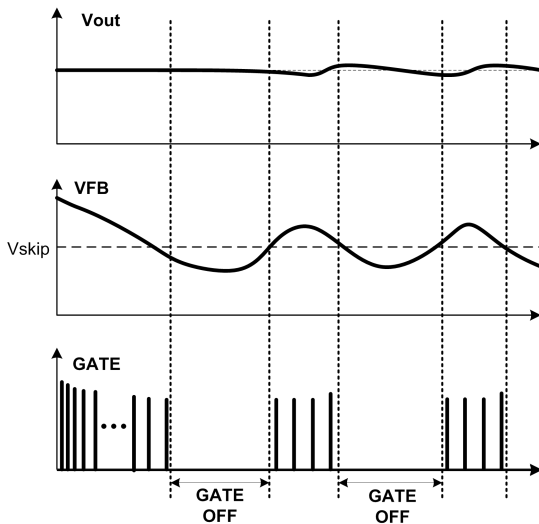

Fig.3

● Built-in Slope Compensation

In the conventional application, the problem of the stability is a critical issue for current mode controlling, when it operates in higher than 50% of the duty-cycle. In DP2293 the slope compensation circuit is integrated by adding voltage ramp onto the current sense input voltage for PWM generation. This greatly improves the close loop stability at CCM and prevents the sub-harmonic oscillation and thus reduces the output ripple voltage.

● Leading Edge Blanking (LEB)

Each time the power MOSFET is switched on, a turn-on spike occurs across the sensing resistor. The spike is caused by primary side capacitance and secondary side rectifier reverse recovery. To avoid premature termination of the switching pulse, an internal leading-edge blanking circuit is built in. During this blanking period (300ns, typical), the PWM comparator is disabled and cannot switch off the gate driver.

● On Chip Thermal Shutdown (OTP)

When the IC temperature is over 165°C, the IC shuts down. Only when the IC temperature drops to 140°C, IC will restart.

● Soft Start

DP2293 features an internal 2ms (typical) soft start that slowly increases the threshold of cycle-by-cycle current limiting comparator during startup sequence. It helps to prevent transformer saturation and reduce the stress on the secondary diode during startup. Every restart attempt is followed by a soft start activation.

● Constant Power Limiting

A proprietary “Constant Power Limiting” block is integrated to achieve constant maximum output power capability over universal AC input range. Based on the duty cycle information, the IC generates OCP threshold according to a proprietary analog algorithm.

● Over Load Protection (OLP)

If over load occurs and V_{FB} is higher than V_{TH_OLP} for more than 75ms (typical), OLP protection will be triggered. The IC will experience an auto-recovery mode protection as mentioned above. The 75ms delay time is to prevent the false trigger from the power-on and turn-off transient.

● VDD Over Voltage Protection (OVP) and Zener Clamp

When VDD voltage is higher than 31V (typical), the IC will stop switching. This will cause VDD fall to be lower than V_{DD_OFF} (typical 9V) and then the system will restart up again. An internal 35V (typical) zener clamp is integrated to prevent the IC from damage.



- **Output Over Voltage Protection (OVP) and Input Brownout Protection (BOP)**

DP2293 integrates programmable output over voltage protection (OVP) and input brownout protection (BOP). When the switching is off, the output voltage is sensed by the resistance divider across the auxiliary winding on PRT pin. If the voltage sensed on PRT pin is higher than V_{OVP} (2.5V typical) last for 6 switching periods, the output over voltage protection (OVP) will be triggered. And the IC will stop switching and enter auto-recovery mode. When the switching is on, the voltage on PRT pin is clamped to low level. If the output current from PRT pin is less than $I_{Brownout_Tr}$ (100uA typical), the input brownout protection (BOP) will be triggered. And the IC will also stop switching and enter auto-recovery mode. The IC will exit the BOP if the current is larger than $I_{Brownout_Re}$ (110uA typical) dropped out from PRT pin.

- **CS Pin Float Protection**

When VDD voltage is higher than V_{DD_ON} (21V typical), IC firstly starts to check whether CS pin is floated. If CS pin is floated, switching is blocked and IC enters auto-recovery mode; otherwise, normal work begins. With this protection, system stability is enhanced.

- **Auto Recovery Mode Protection**

As shown in Fig.4, once a fault condition is detected, PWM switching will stop. This will cause VDD to fall because no power is delivered from the auxiliary winding. When VDD falls to V_{DD_OFF} (typical 9V), the protection is reset and the operating current reduces to the startup current, which causes VDD to rise. The system begins switching when VDD reaches to V_{DD_ON} (typical 21V). However, if the fault still exists, the system will experience the above mentioned process. If the fault has gone, the system resumes normal operation. In this manner, the auto restart can

alternatively enable and disable the switching until the fault condition is disappeared.

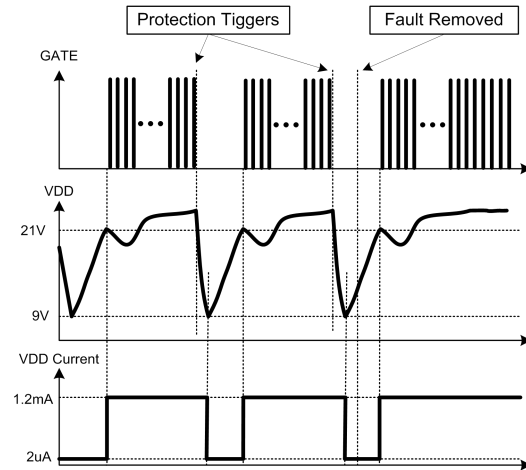

Fig.4

- **Soft Gate Driver**

The output stage of DP2293 is a totem-pole gate driver with 400mA capability. Cross conduction has been avoided to minimize heat dissipation, increase efficiency, and enhance reliability. An internal 13V clamp is added for MOSFET gate protection at higher than expected VDD input. A soft driving waveform is implemented to minimize EMI.



Package Dimension

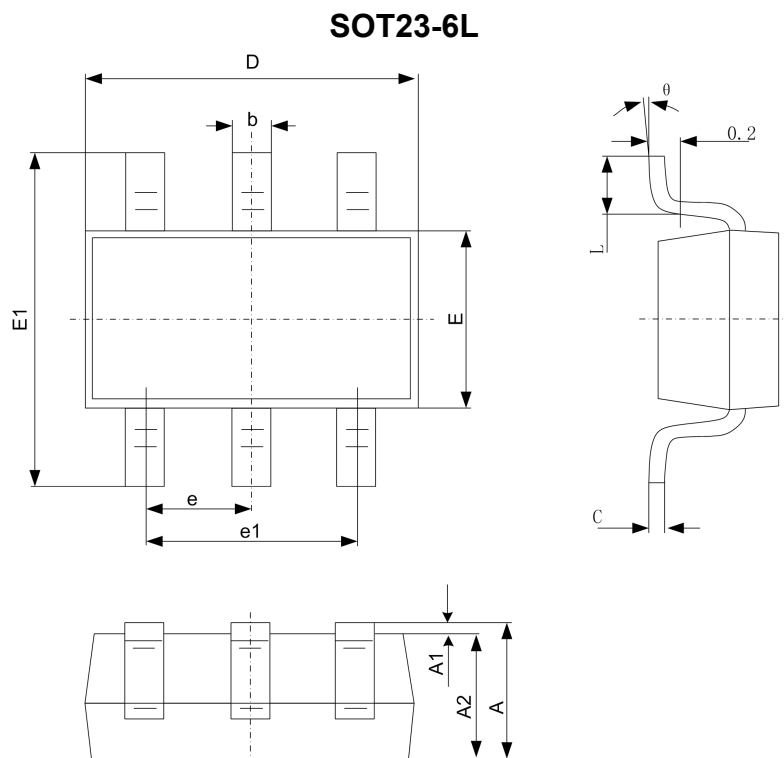

Symbol	Dimensions In Millimeters		Dimensions In Inches	
	Min	Max	Min	Max
A	0.900	1.200	0.035	0.047
A1	0.000	0.150	0.000	0.006
A2	0.900	1.100	0.035	0.043
b	0.300	0.500	0.012	0.020
c	0.100	0.200	0.004	0.008
D	2.800	3.020	0.110	0.119
E	1.500	1.700	0.059	0.067
E1	2.600	3.000	0.102	0.118
e	0.950 (BSC)		0.037 (BSC)	
e1	1.800	2.000	0.071	0.079
L	0.300	0.600	0.012	0.024
θ	0°	8°	0°	8°

X-ON Electronics

Largest Supplier of Electrical and Electronic Components

Click to view similar products for [Switching Voltage Regulators](#) category:

Click to view products by [Developer Microelectronics](#) manufacturer:

Other Similar products are found below :

[FAN53610AUC33X](#) [FAN53611AUC123X](#) [MP2374DS-LF-Z](#) [EN6310QA](#) [NCP81108MNTXG](#) [NCP81109BMNTXG](#) [FAN48610BUC45X](#)
[FAN48617UC50X](#) [R3](#) [KE177614](#) [EP5358LUA](#) [MPQ4423GQ-AEC1-Z](#) [FAN53611AUC12X](#) [MAX809TTR](#) [NCV891234MW50R2G](#)
[AST1S31PUR](#) [NCP81103MNTXG](#) [NCP81203PMNTXG](#) [NCP81208MNTXG](#) [NCP81109GMNTXG](#) [SCY1751FCCT1G](#)
[NCP81109JMNTXG](#) [MP2161AGJ-Z](#) [NCP81241MNTXG](#) [MP2388GQEU-Z](#) [MPQ4481GU-AEC1-P](#) [MP8756GD-P](#) [MPQ2171GJ-P](#)
[MPQ2171GJ-AEC1-P](#) [MP2171GJ-P](#) [NCV1077CSTBT3G](#) [MP28160GC-Z](#) [MPM3509GQVE-AEC1-P](#) [LTM4691EV#PBF](#) [XCL207A123CR-](#)
[G](#) [XDPE132G5CG000XUMA1](#) [XDPE12284C0000XUMA1](#) [LTM4691IV#PBF](#) [MP5461GC-P](#) [MP28301GG-P](#) [MIC23356YFT-TR](#)
[ISL95338IRTZ](#) [MP3416GJ-P](#) [BD9S201NUX-CE2](#) [ISL9113AIRAZ-T](#) [MP5461GC-Z](#) [MPQ2172GJ-AEC1-Z](#) [MPQ4415AGQB-Z](#)
[MPQ4590GS-Z](#) [IR3888AMTRPBFAUMA1](#)