

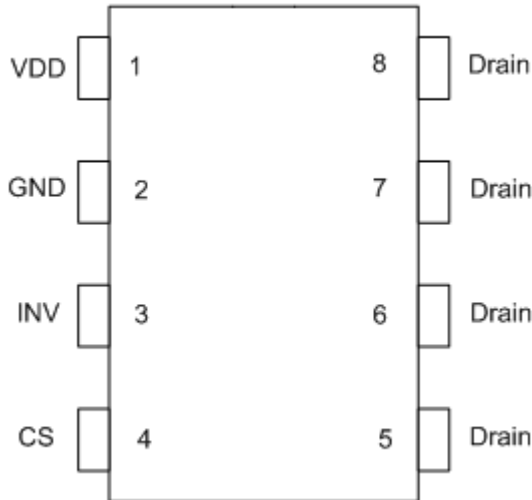

GENERAL INFORMATION

Pin Configuration

The pin map of SOP8 package is shown as below.



Ordering Information

Part Number	Description
DP2500C	SOP8, Halogen free, 4000Pcs/Reel

Note: All Devices are offered in Pb-free Package if not otherwise noted.

Marking Information



DP2500C for product name;

XXXXXX The first X represents the last year, 2014 is 4; The second X represents the month, in A-L 12 letters; The third and fourth X on behalf of the date, 01-31 said; The last two X represents the wafer batch code.

TERMINAL ASSIGNMENTS

Pin Num	Pin Name	I/O	Description
1	VDD	P	Power supply.
2	GND	P	Ground.
3	INV	I	The voltage feedback from auxiliary winding. Connected to resistor divider from auxiliary winding reflecting output voltage.
4	CS	I	Current sense input.
5/6/7/8	Drain	O	The Power MOSFET Drain

THERMAL RESISTANCE RATINGS

SYMBOL	TYPICAL
R θ JC (°C/W)	1.5
R θ JA (°C/W)	90

Absolute Maximum Ratings

Parameter	Value
Drain Voltage (off state)	-0.3 to 650V
VDD Zener Clamp Voltage	V _{DD Clamp}
VDD Clamp Continuous Current	10 mA
CS Input Voltage	-0.3 to 7V
INV Input Voltage	-0.3 to 7V
Maximum Operating Junction Temperature T _J	150 °C
Min/Max Storage Temperature T _{stg}	-55 to 150 °C
Lead Temperature (Soldering, 10secs)	260 °C

Note: Stresses beyond those listed under “absolute maximum ratings” may cause permanent damage to the device. These are stress ratings only, functional operation of the device at these or any other conditions beyond those indicated under “recommended operating conditions” is not implied. Exposure to absolute maximum-rated conditions for extended periods may affect device reliability.



BLOCK DIAGRAM

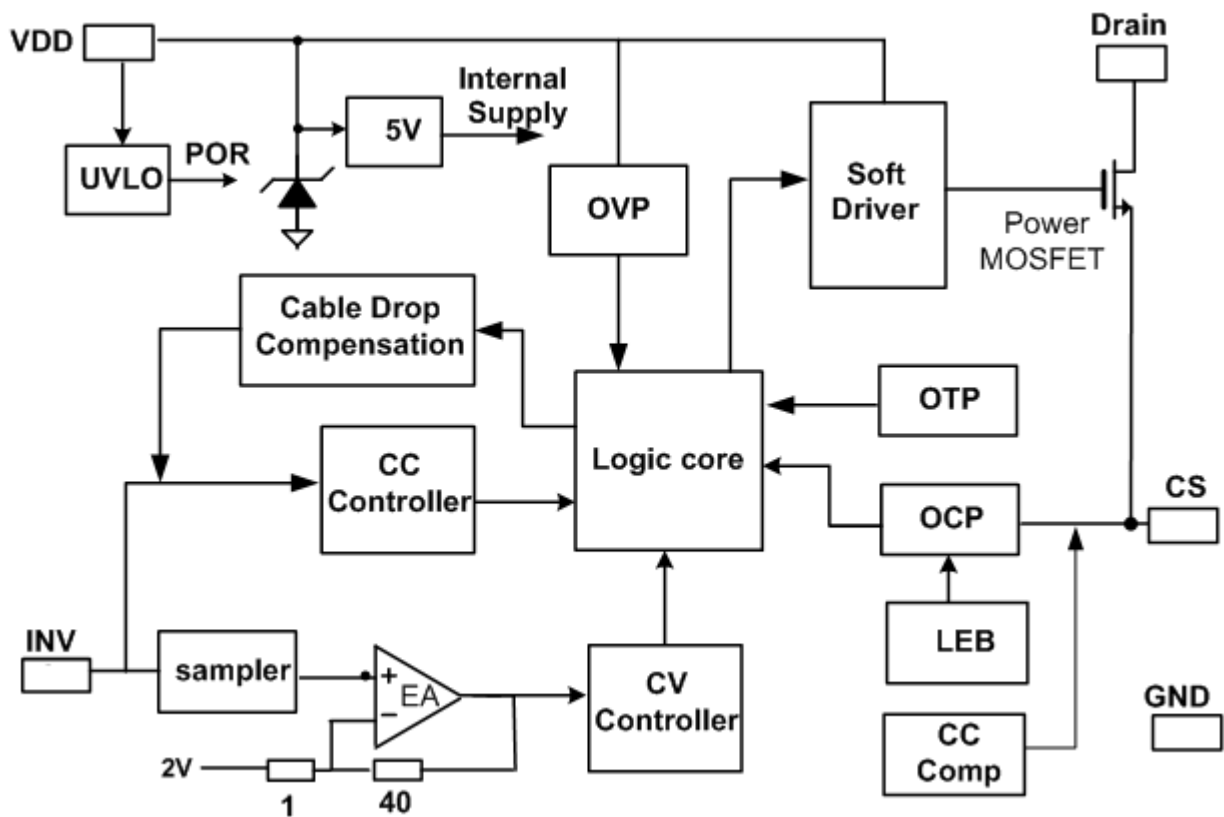

RECOMMENDED OPERATING CONDITION

Symbol	Parameter	Min	Max	Unit
VDD	VDD Supply Voltage	11	27	V
T _A	Operating Ambient Temperature	-40	85	°C

**ELECTRICAL CHARACTERISTICS**(T_A = 25°C, VDD=18V if not otherwise noted)

Symbol	Parameter	Test Conditions	Min	Typ	Max	Unit
Supply Voltage Section (VDD Pin)						
I _{VDD_st}	Start-up current into VDD pin			2	20	uA
I _{VDD_Op}	Operation Current	V _{INV} =3V, VDD=20V		1	1.5	mA
I _{VDD_standby}	Standby Current			0.5	1	mA
V _{DD_ON}	VDD Under Voltage Lockout Exit		15	16.3	17.5	V
V _{DD_OFF}	VDD Under Voltage Lockout Enter		8	9	10	V
V _{DD_OVP}	VDD OVP Threshold		28	30	32	V
V _{DD_Clamp}	VDD Zener Clamp Voltage	I(V _{DD}) = 7 mA	32.5	34.5	36.5	V
Feedback Input Section (INV Pin)						
V _{INV_REF}	Internal Error Amplifier (EA) Reference Input		1.97	2.0	2.03	V
V _{INV_SLP}	Short Load Protection (SLP) Threshold			0.7		V
T _{INV_Short}	Short Load Protection (SLP) Debounce Time			10		ms
V _{INV_DEM}	Demagnetization Comparator Threshold			25		mV
T _{off_min}	Minimum OFF time			2		us
T _{off_max}	Maximum OFF time			5		ms
I _{Cable_max}	Maximum Cable Drop compensation current			63		uA
Current Sense Input Section (CS Pin)						
T _{LEB}	CS Input Leading Edge Blanking Time			500		ns
V _{cs(max)}	Current limiting threshold		490	500	510	mV
T _{D_OCP}	Over Current Detection and Control Delay			100		ns
Over temperature Protection						
T _{SD}	Thermal Shutdown		---	165	--	°C
T _{RC}	Thermal Recovery			135	--	°C
Power MOSFET Section (Drain Pin)						
V _{BR}	Power MOSFET Drain Source Breakdown Voltage		650			V
R _{dson}	Static Drain-Source On Resistance			2.6	3.1	Ohm



CHARACTERIZATION PLOTS

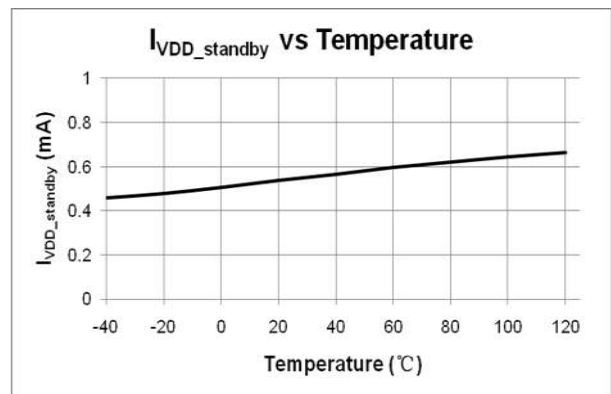
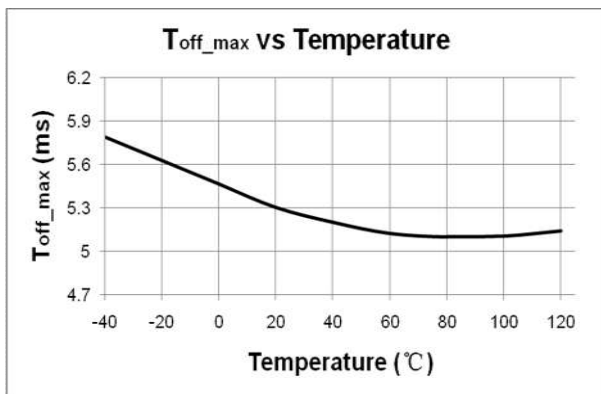
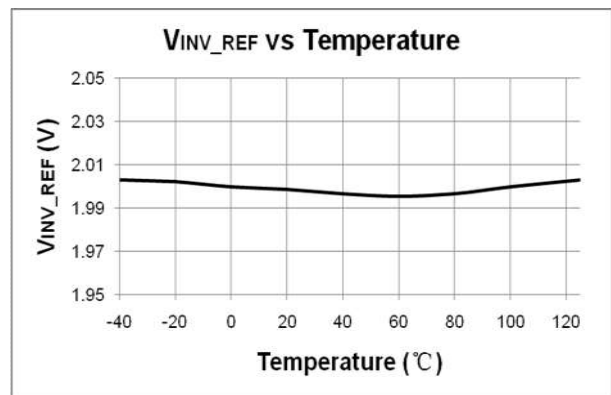
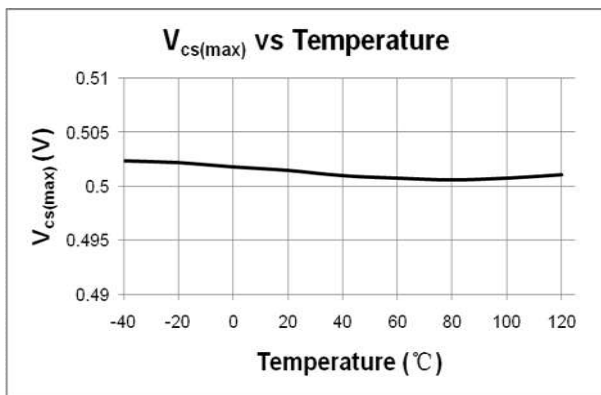
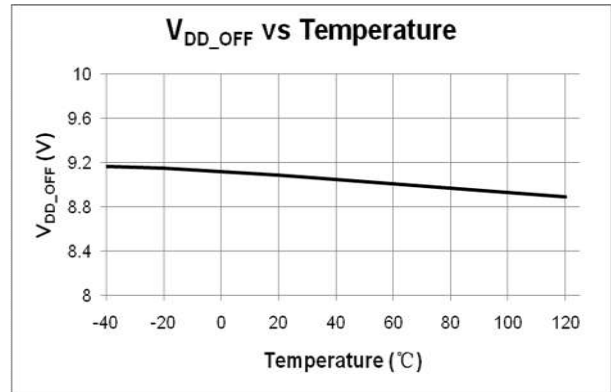
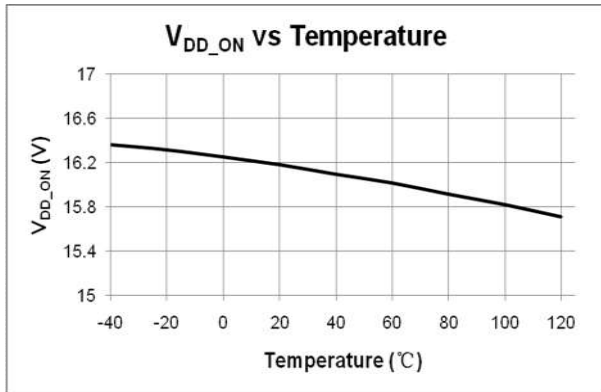



OPERATION DESCRIPTION

DP2500C is a cost effective PWM power switch optimized for off-line low power AC/DC applications including battery chargers and adapters. It operates in Primary Side Regulation (PSR), thus opto-coupler and TL431 are not required. High precision CV and CC control can be achieved to meet most small power charger and adapter applications requirements.

● **Startup Current and Start up Control**

Startup current of DP2500C is designed to be very low (typically 2uA) so that VDD could be charged up above UVLO threshold level and device starts up quickly. A large value startup resistor can therefore be used to minimize the power loss yet reliable startup in application.

● **Operating Current**

The operating current of DP2500C is as low as 1mA. Good efficiency is achieved by the low operating current together with extended burst mode control schemes at No/light load conditions.

● **Primary Side CC/CV Control**

DP2500C is designed to produce good CC/CV control. In charger applications, a discharged battery charging starts in CC portion of the curve until it is nearly full charged and smoothly switched to operate in CV portion of the curve. In an AC/DC adapter, the normal operation occurs only on the CV portion of the curve. The CC portion provides output current limiting.

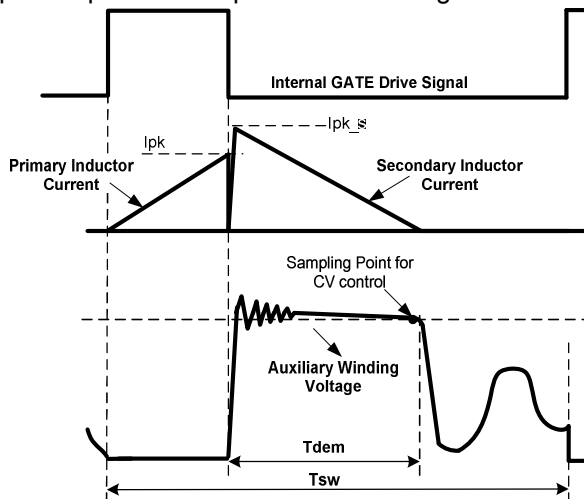

As shown by Fig 1, when the PWM switching is off the secondary side diode is conducted and the auxiliary winding voltage is proportion to the output voltage. Via a resistor divider connected

between the auxiliary winding and INV (pin 3), the auxiliary voltage is sampled at the end of the demagnetization and it is hold until the next sampling. The sampled voltage is compared with V_{INV_REF} (2.0V) and the error is amplified by an internal Error Amplifier (EA). The internal EA output reflects the load condition and control the PWM switching frequency to regulate the output voltage, thus constant voltage (CV) can be achieved.

When system enters over load condition, the output voltage falls down and the INV sampled voltage should be lower than 2V internal reference which makes system enter CC Mode automatically.

● **Multi Mode CV Operation for High Efficiency**

DP2500C is a multi-mode PSR controller. In CV mode, the controller changes the mode of operation by sampling INV voltage. Under the medium to large load conditions, the IC operates in PWM mode, which improves the system audio noise performance. Under normal to light load conditions, the IC operates in PFM mode to achieve high efficiency. The IC can achieve less than 75mW standby power, as shown in Fig.2

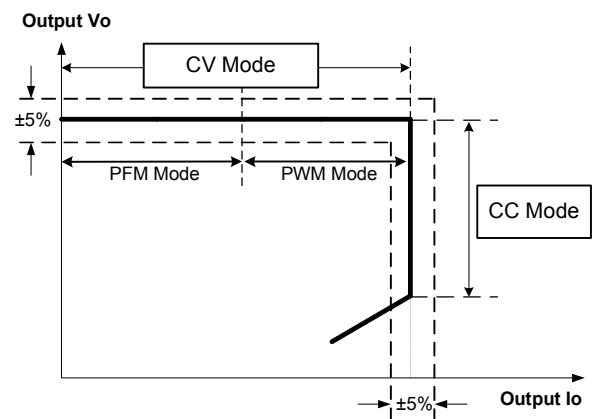

Fig.2

● **CC Operation Switching Frequency**

The switching frequency of DP2500C is adaptively controlled according to the load conditions and the operation modes. For flyback operation in DCM, the maximum output power is given by

$$Po_{MAX} = \frac{1}{2} L_p F_{SW} I_p^2$$

Where L_p indicate the inductance of primary winding and I_p is the peak current of primary winding.



Refer to the equation above, the change of the primary winding inductance results in the change of the maximum output power and the constant output current in CC mode. To compensate the change from variations of primary winding inductance, the switching frequency is locked by and internal loop such that the switching frequency is

$$F_{SW} = \frac{1}{2T_{DEM}}$$

Since T_{DEM} is inversely proportional to the inductance, as a result, the product of L_p and F_{sw} is constant, thus the maximum output power and constant current in CC mode will not change as primary winding inductance changes. Up to ± 10% variation of the primary winding inductance can be compensated.

● **Adjustable CC Point and Output Power**

In DP2500C, the CC point and maximum output power can be externally adjusted by external current sense resistor R_s at CS pin as illustrated in typical application diagram. The larger R_s, the smaller CC point is, and the smaller output power becomes, and vice versa as shown in Fig.3.

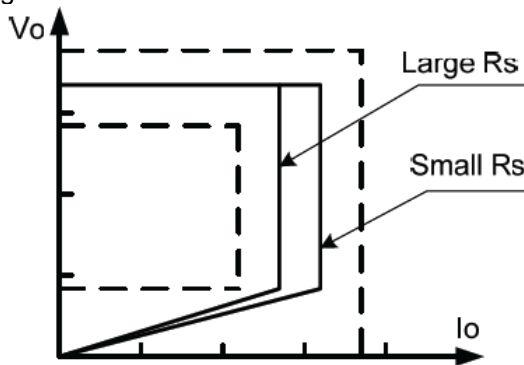

Fig.3

● **Current Sensing and Leading Edge Blanking**

Cycle-by-Cycle current limiting is offered in DP2500C. The switch current is detected by a sense resistor into the CS pin. An internal leading edge blanking circuit is built in. During this blanking period (500ns, typical), the cycle-by-cycle current limiting comparator is disabled and cannot switch off the GATE driver.

● **Audio Noise Free Operation**

DP2500C can provide audio noise free operation from full loading to zero loading.

● **Optimized Dynamic Response**

In DP2500C, an optimized dynamic response control is integrated to improve system dynamic

response performance, which enables charger system to meet the USB charge requirements.

● **Programmable Cable Drop Compensation**

In DP2500C, cable drop compensation is implemented to achieve good load regulation. An offset voltage is generated at INV pin by an internal current flowing into the resistor divider. The current is proportional to the switching off time, as a result, it is inversely proportional to the output load current, thus the drop due to the cable loss can be compensated. As the load current decreases from full-load to no-load, the offset voltage at INV pin will increase. It can also be programmed by adjusting the resistance of the divider to compensate the drop for various cable lines used.

The percentage of maximum compensation is

$$\frac{\Delta V}{V_{out}} \approx \frac{I_{cable_max} \times (R1/R2)}{V_{INV_REF}} \times 100\%$$

ΔV is load compensation voltage and V_{out} is output voltage;

For example: R₁=3K Ω , R₂=18K Ω , The percentage of maximum compensation is given by

$$\frac{\Delta V}{V_{out}} = \frac{63\mu A \times (3K/18K)}{2V} \times 100\% = 8.1\%$$

● **Over Temperature Protection (OTP)**

When the IC temperature is over 165 °C, the IC shuts down. Only when the IC temperature drops to 135 °C, IC will restart.

● **Output Short Load Protection**

In DP2500C, the output is sampled on INV pin and then compared with a threshold of UVP (0.7V typically) after an internal blanking time (10ms typical). When sensed INV voltage is below 0.7V, the IC will enter into Short Load Protection (SLP) mode, in which the IC will enter into auto recovery protection mode.

● **VDD OVP and Zener Clamp**

When VDD voltage is higher than 30V (typical), the IC will stop switching. This will cause VDD fall down to be lower than VDD_OFF (typical 9V) and then the system will restart up again. An internal 34.5V (typical) zener clamp is integrated to prevent the IC from damage.

● **Soft Gate Drive**

DP2500C has a soft totem-pole gate driver with optimized EMI performance. An internal 16V clamp is added for MOSFET gate protection at higher than expected VDD input.



Package Dimension

SOP8

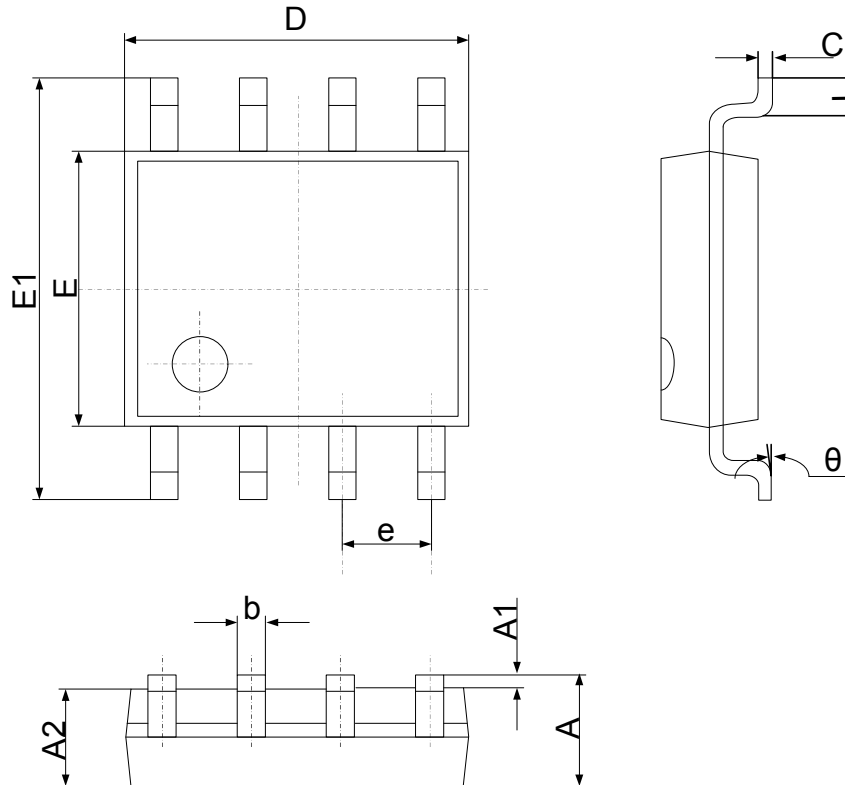

Symbol	Dimensions in Millimeters		Dimensions in Inches	
	Min	Max	Min	Max
A	1.350	1.750	0.053	0.069
A1	0.100	0.250	0.004	0.010
A2	1.350	1.550	0.053	0.061
b	0.330	0.510	0.013	0.020
c	0.170	0.250	0.006	0.010
D	4.700	5.100	0.185	0.200
E	3.800	4.000	0.150	0.157
E1	5.800	6.200	0.228	0.244
e	1.270 (BSC)		0.050 (BSC)	
L	0.400	1.270	0.016	0.050
theta	0°	8°	0°	8°

X-ON Electronics

Largest Supplier of Electrical and Electronic Components

Click to view similar products for [Switching Voltage Regulators](#) category:

Click to view products by [Developer Microelectronics](#) manufacturer:

Other Similar products are found below :

[FAN53610AUC33X](#) [FAN53611AUC123X](#) [MP2374DS-LF-Z](#) [EN6310QA](#) [NCP81108MNTXG](#) [NCP81109BMNTXG](#) [FAN48610BUC45X](#)
[FAN48617UC50X](#) [R3](#) [KE177614](#) [EP5358LUA](#) [MPQ4423GQ-AEC1-Z](#) [FAN53611AUC12X](#) [MAX809TTR](#) [NCV891234MW50R2G](#)
[AST1S31PUR](#) [NCP81103MNTXG](#) [NCP81203PMNTXG](#) [NCP81208MNTXG](#) [NCP81109GMNTXG](#) [SCY1751FCCT1G](#)
[NCP81109JMNTXG](#) [MP2161AGJ-Z](#) [NCP81241MNTXG](#) [MP2388GQEU-Z](#) [MPQ4481GU-AEC1-P](#) [MP8756GD-P](#) [MPQ2171GJ-P](#)
[MPQ2171GJ-AEC1-P](#) [MP2171GJ-P](#) [NCV1077CSTBT3G](#) [MP28160GC-Z](#) [MPM3509GQVE-AEC1-P](#) [LTM4691EV#PBF](#) [XCL207A123CR-](#)
[G](#) [XDPE132G5CG000XUMA1](#) [XDPE12284C0000XUMA1](#) [LTM4691IV#PBF](#) [MP5461GC-P](#) [MP28301GG-P](#) [MIC23356YFT-TR](#)
[ISL95338IRTZ](#) [MP3416GJ-P](#) [BD9S201NUX-CE2](#) [ISL9113AIRAZ-T](#) [MP5461GC-Z](#) [MPQ2172GJ-AEC1-Z](#) [MPQ4415AGQB-Z](#)
[MPQ4590GS-Z](#) [IR3888AMTRPBFAUMA1](#)