

FTT-10A Free Topology Twisted Pair Transceiver Model 50051



Features

- Complete LonWorks® transformer-isolated, free topology communication transceiver
- Replacement for the FTT-10 transceiver1
- Compatible with the FTT-10 Free Topology Transceiver and LPT-10 Link Power Transceiver;
- Differential Manchester coded signaling for polarity insensitive network wiring
- 78 kilobits per second bit rate up to distances of 500 meters (free topology), or 2700 meters (doubly terminated bus) worst case
- Supports free topology star, bus, and loop wiring
- Automatic clock detection at 5, 10, or 20MHz
- Designed to comply with FCC and EN55022 Level B EMI requirements
- UL, CSA, TÜV Recognized component
- LonMark® certifiable for interoperability

Description

The FTT-10A Free Topology Twisted Pair Transceiver provides a simple, cost-effective method of adding a LonWorks transceiver to any Neuron® Chip-based control system. A replacement for the popular FTT-10 transceiver1, the FTT-10A transceiver supports polarity insensitive, free topology wiring, freeing the system installer from the need to wire using a bus topology. Star, bus, and loop wiring are all supported by this architecture. Free topology wiring reduces the time and expense of system installation by allowing the wiring to be installed in the most expeditious manner. It also simplifies network expansion by eliminating restrictions on wire routing, splicing, and node placement.

The FTT-10A transceiver consists of an isolation transformer that is integrated with a 78kbps differential Manchester coded communication transceiver. Pins are provided for connection to the Neuron Chip Communications Port (CP) and clock lines, +5V power, and the twisted pair network. The pins are keyed to prevent accidental reversal during mounting. The FTT-10A transceiver provides automatic detection of the input clock frequency at 5, 10, and 20MHz.

The transceiver is housed in an encapsulated plastic shell which contains the transformer and signal processing electronics. The compact package is only 7.2mm (0.28 inches) high and is ideal for use in very low profile applications such as DIN packs. The sealed housing protects the transceiver should conformal coating or other forms of environmental sealing be required on the printed circuit assembly.

The FTT-10A transceiver is compatible with Echelon's LPT-10 Link Power Transceiver, and these transceivers can communicate with each other on a single twisted pair cable. This capability provides an inexpensive means of interfacing to nodes whose current or voltage requirements would otherwise exceed the capacity of the link power segment. When equipped with an FTT-10A transceiver, these nodes can be operated from a local power supply without the need for additional electrical isolation from the link power network.

The FTT-10A transceiver also provides electrical isolation for I/O devices that are grounded, allowing such devices to be used on a link power network segment. Each segment of a link power network utilizes a non-isolated design with a single ground point at the LPI-10 Link Power Interface. Proper operation requires that the integrity of a single point ground be maintained throughout the segment, including I/O devices that are connected to a Neuron Chip. In many applications, I/O devices are grounded to meet either functional requirements or safety regulations. The transformer of the FTT-10A transceiver electrically isolates the node from the segment, allowing devices connected to the node to be grounded without impairing communications.

A twisted pair channel may be comprised of multiple segments separated by physical layer repeaters. A physical layer repeater permits a twisted pair network to grow inexpensively to encompass many more nodes or longer wire distances than would otherwise be possible. The FTT-10A transceiver includes a physical layer repeater feature that allows LonTalk® data to be exchanged between network segments by interconnecting two or more FTT-10A transceivers; FTT-10A-to-LPT-10 physical layer repeaters require the addition of an external logic circuit. If the repeater includes an LPT-10 transceiver, then the internal power supply of the LPT-10 transceiver can power the FTT-10A transceiver.

Using the FTT-10A transceiver can save thousands of hours of development time compared with a custom-designed transceiver. The transceiver is designed to comply with both FCC and EN55022 EMI requirements, minimizing time consuming and expensive testing. As a UL, CSA, and TÜV Recognized component, the FTT-10A transceiver can be integrated into a product with minimal additional safety testing. The transceiver is small enough to fit into virtually any application, and is economically priced for OEM applications of any volume.

Echelon offers a comprehensive range of development tools, network interfaces, routers, and network services tools to simplify the task of designing products

using the FTT-10A transceiver. Technical support for the transceiver is available through Echelon's LonSupport™ Premier technical assistance program.

Typical Free Topologies Supported by the FTT-10A Free Topology Transceiver

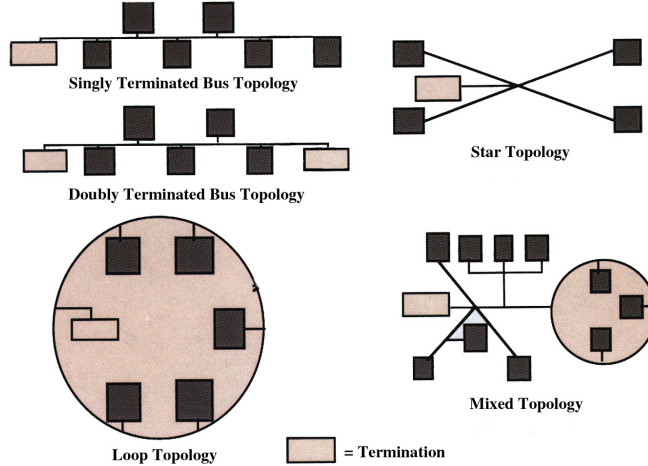

FTT-10A System Block Diagram

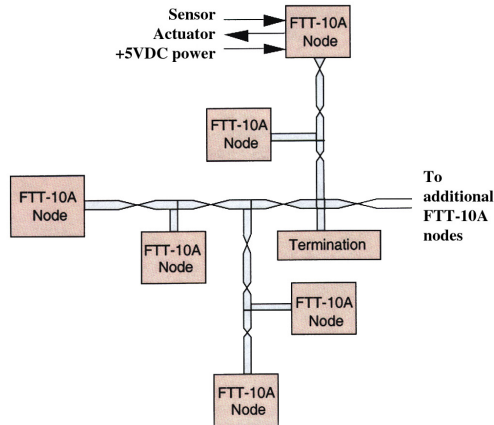

Free Topology Channel Illustrating FTT-10A and LPT-10 Transceiver Compatibility & Network Expansion Using Physical Layer Repeaters

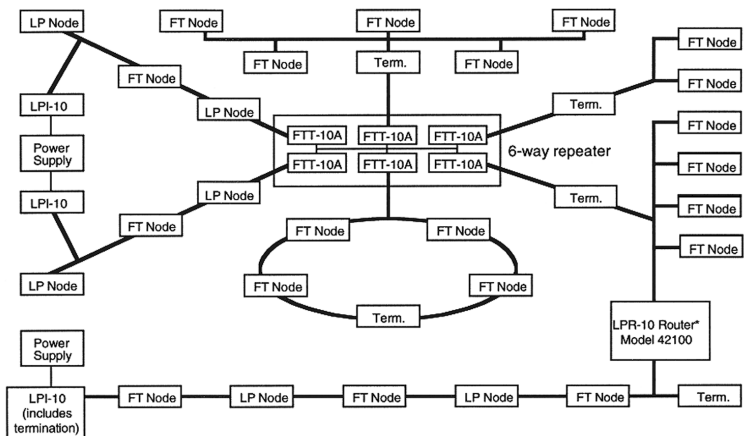

Specifications

Function	Free topology, transformer-isolated twisted pair transceiver
Data Communications Type	Differential Manchester codin
Network Polarity	Polarity insensitive
Isolation Between Network and	
0-60Hz, 60 seconds	1000Vrms
0-60Hz, continuous	277Vrms ²
Input Supply Voltage	+5VDC ±5%
Supply Current:	Receive mode
Transmit mode	5mA maximum
	20mA maximum
EMI	Designed to comply with FCC Part 15 Level B and EN55022 Level B
ESD	Designed to comply with IEC1000-4-2, Level 4
Radiated Electromagnetic Susceptibility	Designed to comply with IEC1000-4-3, Level 3
Fast Transient/Burst Immunity	Designed to comply with IEC1000-4-4, Level 4
Surge Immunity	Designed to comply with IEC1000-4-5, Level 3
Listings	UL 1950, CSA C22.2 No. 950, TÜV EN60950
Clock Rates	Automatically detects 5, 10, or 20MHz input clock supplied by Neuron Chip
Transmission Speed	78 kilobits per second
Number of Transceivers Per Segment	Up to 64
number of LPT-10 transceivers	
Network Wiring	22 to 16AWG twisted pair; see User's Guide for qualified cable types
Network Length in Free Topology ³	1000m (3,280 feet) maximum total wire with one repeater
	500m (1,640 feet) maximum total wire with no repeaters
	500m (1,640 feet) maximum node-to-node distance
Network Length in Doubly-Terminated Bus Topology ³	5400m (17,710 feet) with one repeater
	2700m (8,850 feet) with no repeaters
Maximum Stub Length in Doubly-Terminated Bus Topology	3m (9.8 feet)
Network Termination	One terminator in free topology; two terminators in bus topology (see User's Guide)
Power-down Network Protection	High impedance when unpowered
Physical Layer Repeater source OR one	Two-way repeater requires two FTT-10A transceivers and clock oscillator plus external power FTT-10A transceiver, one LPT-10 transceiver, control circuitry, and clock oscillator.
Operating Temperature	-40 to +85°C
Operating Humidity	25-90% RH @ 50°C, non-condensing
Non-operating Humidity	95% RH @ 50°C, non-condensing
Approximate Dimensions	17.8mm L x 7.2mm H x 13.7mm W (0.70" x 0.28" x 0.54")
Packaging	Encapsulated plastic shell

Ordering Information

Product	Echelon Model Number
FTT-10A Free Topology Transceiver	50051
LonWorks FTT-10A Free Topology Transceiver User's Guide (order separately-not shipped with product)	078-0156-0

- Notes:**
1. The FTT-10A transceiver is a replacement for the FTT-10 transceiver for all published applications except repeaters - see the LonWorks FTT-10A Free Topology Transceiver User's Guide for details. The FTT-10A transceiver does not support 1.25MHz or 2.5MHz Neuron Chip clock operation. Some PC board modification may be required due to mechanical differences between the FTT-10 and FTT-10A transceivers. See the individual user's guides for details.
 2. Safety agency hazardous voltage barrier requirements are not supported.
 3. Network segment length varies depending on wire type. See the LonWorks FTT-10A Free Topology Transceiver User's Guide for detailed specifications.



Copyright © 2001-2002, Echelon Corporation. Echelon, LON, LonWorks, LonMark, LonBuilder, Nodebuilder, LonManager, Digital Home, LonTalk, Neuron, 3120, 3150, the LonMark logo, and the Echelon logo are trademarks of Echelon Corporation registered in the United States and other countries. LNS, the LNS Powered Logo, LonPoint, SMX, LonResponse, LONews, LonSupport, LonMaker, iLON, Bringing the Internet to Life, Open Systems Alliance, and the Open Systems Alliance logo are trademarks of Echelon Corporation. Other trademarks belong to their respective corporations. **Disclaimer** Neuron Chips, Free Topology Twisted Pair Transceiver Modules, and other OEM Products were not designed for use in equipment or systems which involve danger to human health or safety or a risk of property damage and Echelon assumes no responsibility or liability for use of the Neuron Chips or Free Topology Twisted Pair Transceiver Modules in such applications. ECHELON MAKES AND YOU RECEIVE NO WARRANTIES OR CONDITIONS, EXPRESS, IMPLIED, STATUTORY OR IN ANY COMMUNICATION WITH YOU, AND ECHELON SPECIFICALLY DISCLAIMS ANY IMPLIED WARRANTY OF MERCHANTABILITY OR FITNESS FOR A PARTICULAR PURPOSE

X-ON Electronics

Largest Supplier of Electrical and Electronic Components

Click to view similar products for [Other Modules](#) category:

Click to view products by [Dialog Semiconductor](#) manufacturer:

Other Similar products are found below :

[AC1310](#) [AXXRPFKSSD](#) [B7A-R6F36](#) [RMS3CC080](#) [96RC-SAS-8P-PE-AD](#) [96RC-SAS-4P-PE-AD1](#) [VROCISSDMOD](#) [RS3WC080](#)
[OKY3525-1](#) [OKY3065-6](#) [OKY3199-7](#) [OKY3222-2](#) [OKY3318](#) [OKY3318-1](#) [OKY3318-3](#) [OKY3368](#) [OKY3368-1](#) [OKY3369-2](#) [OKY3369-3](#)
[OKY3370-1](#) [OKY3374-1](#) [OKY3375-6](#) [OKY3378-1](#) [OKY3380-2](#) [OKY3381](#) [OKY3387](#) [OKY3416](#) [OKY3420-5](#) [OKY3420-7](#) [OKY3425](#)
[OKY3431-2](#) [OKY3443-1](#) [OKY3444-2](#) [OKY3449](#) [OKY3452-3](#) [OKY3459](#) [OKY3460-4](#) [OKY3463-5](#) [OKY3471-4](#) [OKY3471-6](#) [OKY3481-2](#)
[OKY3482](#) [OKY3483](#) [OKY3507](#) [OKY3551-1](#) [OKY3605](#) [OKY3919](#) [FIT0827](#) [FIT0832](#) [FIT0767](#)