

IO-Link Device IC

PLEASE NOTE: *This Datasheet is preliminary. Please note the available Errata sheet at www.dialog-semiconductor.com/products/cce4503*

General Description

The CCE4503 is an easy-to-use device side IO-Link compliant transceiver. It combines IO-Link compliant communication capability with advanced protection circuitry and additional features while keeping the application small and simple. Controlled by an UART interface (TXD, RXD, TXEN), the output drivers can be configured as PNP, NPN or Push-Pull. Three LDO options and an automatic wake-up detection simplify the overall system requirements and reduce the need for additional external circuitry. The integrated protection features such as reverse-polarity protection, overcurrent protection, undervoltage detection and thermal protection ensure a robust functionality and communication. With the small 3mm x 3mm DFN10 package size, it is especially suitable for space limited sensor and actuator applications.

Key Features

- IO-Link Compliant Transceiver
- One IO-Link channel with up to 250 mA permanent driving current
 - 350 mA peak (typ.)
- Configurable PNP-, NPN- and Push-Pull mode
- Configurable current limit
- Configurable slew rate limitation for optimized EMC
- Wake-up detection
- Small DFN 10-pin package
- 3 LDO Options with up to 20 mA
 - 3.3V LDO output
 - 5V LDO output
 - External LDO
- Reverse-polarity protection
- Overcurrent detection
- Undervoltage detection
- Overtemperature detection

Applications

- IO-Link Sensors
- IO-Link Actuators
- High voltage level shifter
- Industrial automation

System Diagram

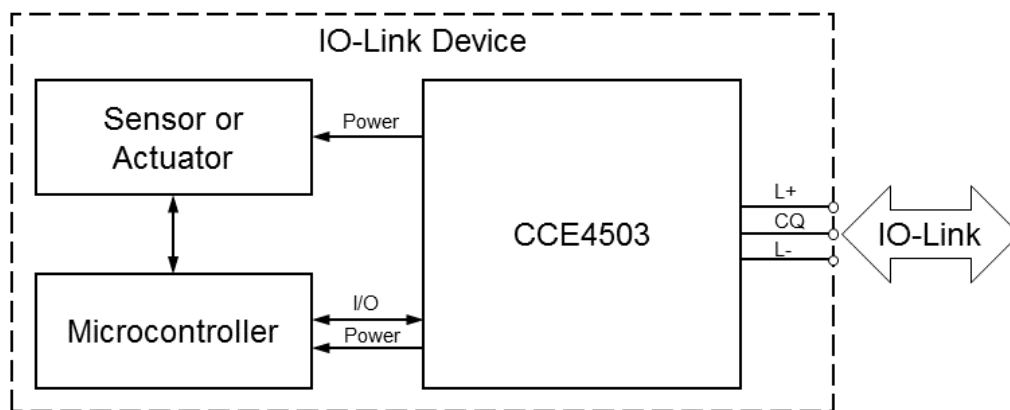

Figure 1: System Diagram

IO-Link Device IC

Contents

General Description	1
Key Features	1
Applications	1
System Diagram	2
Contents	3
Figures	4
Tables	4
1 Block Diagram	5
2 Pinout	6
3 Characteristics	7
3.1 Absolute Maximum Ratings	7
3.2 Recommended Operating Conditions	8
3.3 Electrical Characteristics	8
3.4 Thermal Characteristics	10
4 Functional Description	11
4.1 Output stage	11
4.2 Current limit and slew rate configuration	12
4.3 Automatic Recovery	12
4.4 Wake-up detection	12
4.5 Error output handling	13
4.6 Overtemperature detection	13
4.7 Allowed Reverse polarity connections	13
5 Package Information	14
5.1 Package Outlines	14
5.2 Soldering Information	14
6 Ordering Information	15
7 Application Information	15
Revision History	16

IO-Link Device IC

Figures

Figure 1: System Diagram.....	2
Figure 2: Block Diagram.....	5
Figure 3: DFN10 Pinout Diagram (Top View).....	6
Figure 4: Automatic recovery.....	12
Figure 5: DFN10 Package Outline Drawing.....	14
Figure 6: CCE4503 application.....	15

Tables

Table 1: Pin Description.....	6
Table 2: Pin Type Definition.....	7
Table 3: Absolute Maximum Ratings.....	7
Table 4: Recommended Operating Conditions.....	8
Table 5: Input / Output CQ.....	8
Table 6: Digital I/O.....	9
Table 7: 3.3V / 5V Voltage Regulator.....	10
Table 8: Thermal characteristics.....	10
Table 9: Output stage truth table.....	11
Table 10: Current limit and slew rate configuration.....	12
Table 11: Ordering Information.....	15

1 Block Diagram

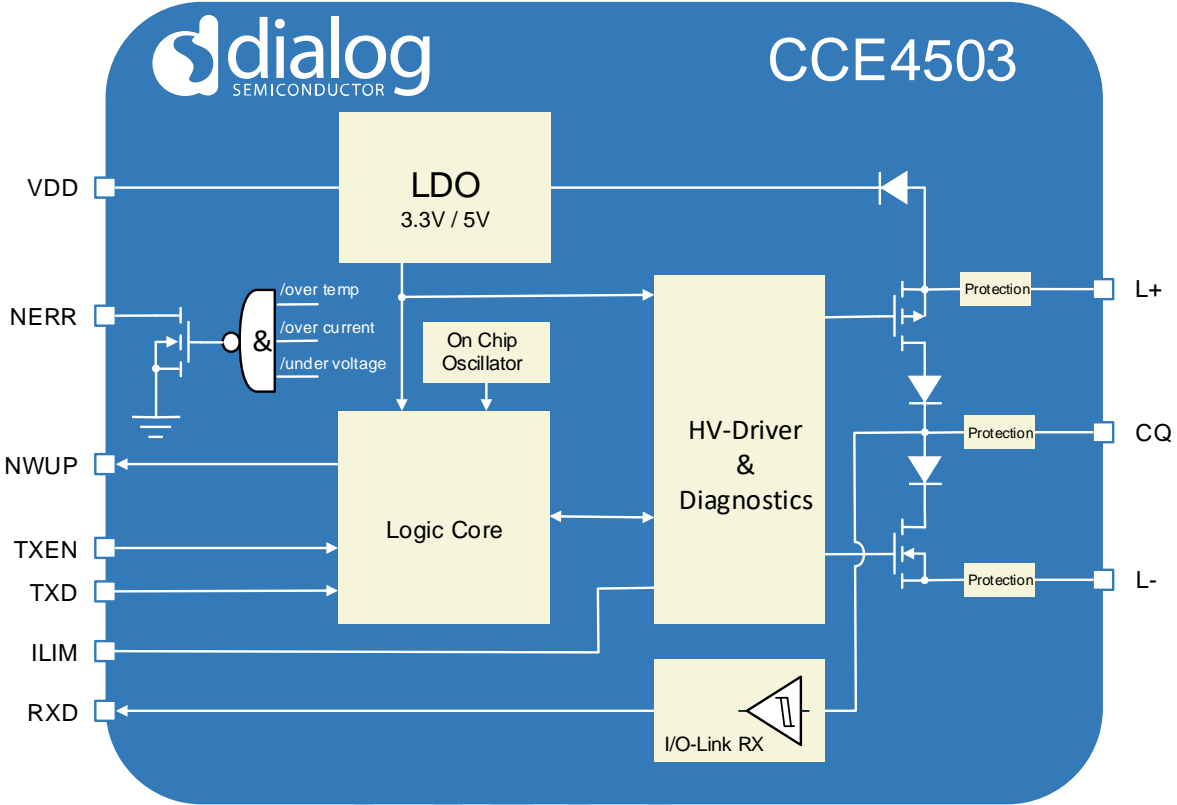

Figure 2: Block Diagram

2 Pinout

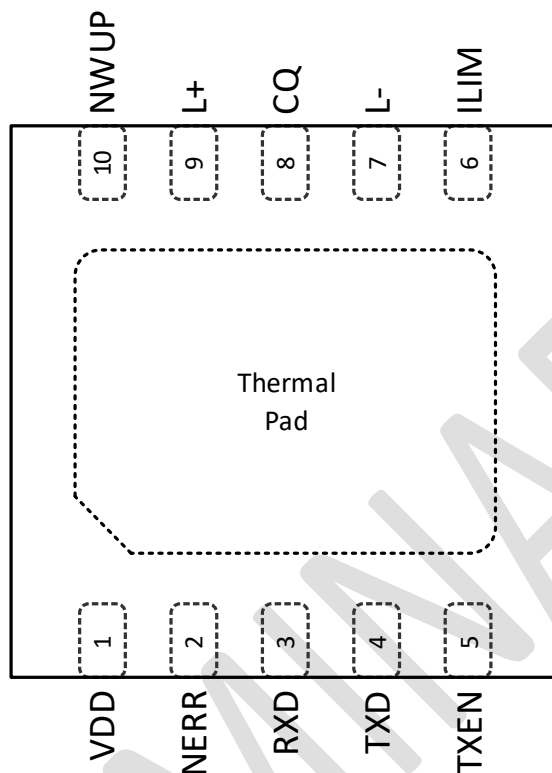

Figure 3: DFN10 Pinout Diagram (Top View)

Table 1: Pin Description

Pin No.	Pin Name	Type (Table 2)	Reset State	Description
1	VDD	PWR		3.3V - 5V Supply Voltage Input / Output
2	NERR	OD	High-Z	Error Output (Overcurrent detection, Undervoltage detection, Overtemperature detection)
3	RXD	DO		Channel signal output
4	TXD	DI, PU		Channel signal input
5	TXEN	DI, PD		Channel driver enable
6	ILIM	AI		Current Limit configuration
7	L-	PWR		Ground supply (IO-Link)
8	CQ	DIO		IO-Link data
9	L+	PWR		Positive supply (IO-Link)
10	NWUP	OD	High-Z	Wake-up detection (Channel short detection)
PAD	Thermal Pad	GND		Thermal Pad, connect to VSS or leave open

IO-Link Device IC

Table 2: Pin Type Definition

Pin Type	Description	Pin Type	Description
DI	Digital input	AI	Analog input
DO	Digital output	AO	Analog output
DIO	Digital input/output	AIO	Analog input/output
OD	Digital Output open drain	BP	Back drive protection
PU	Pull-up resistor (fixed)	SPU	Switchable pull-up resistor
PD	Pull-down resistor (fixed)	SPD	Switchable pull-down resistor
PWR	Power	GND	Ground

3 Characteristics

3.1 Absolute Maximum Ratings

Stresses beyond those listed under Absolute Maximum Ratings may cause permanent damage to the device. These are stress ratings only, so functional operation of the device at these or any other conditions beyond those indicated in the operational sections of the specification are not implied. Exposure to Absolute Maximum Rating conditions for extended periods may affect device reliability.

Table 3: Absolute Maximum Ratings

Parameter	Conditions	Name	Min	Max	Unit
Supply Voltage	Static, referenced to V_L	$V_{L+} - V_{L-}$	-40	40	V
Supply Voltage	Dynamic ($t \leq 100 \mu\text{s}$)	$V_{L+} - V_{L- \text{pulse}}$	-42	42	V
Operating Temperature	Ambient temperature	T_{amb}	-40	+125	°C
Storage Temperature		T_{storage}	-55	+175	°C
Junction Temperature		T_j	-40	+150	°C
Voltage at pin CQ	Referenced to V_L : $V_{CQ} - V_L$	$V_{CQ, \text{max}}$	V_{L-}	V_{L+}	V
Voltage at all other pins	Referenced to V_L	V_{IOMax}	-0.7	$V_{DD} + 0.7$	V
ESD protection	JS-001-2012 HBM	V_{ESD}	4		kV
	JEDEC JESD78D Class1	I_{latchup}	Tbd		mA
Soldering Temperature	12 s max.	T_{solder}		Tbd	°C
Logic Level Supply Voltage		$V_{DD, \text{max}}$		6	V
Output current	At pin RXD, NWUP, NERR	I_{OutMax}	-5	5	mA

IO-Link Device IC

3.2 Recommended Operating Conditions

Table 4: Recommended Operating Conditions

Parameter	Conditions	Pin	Name	Min	Typ	Max	Unit
Main Supply Voltage		7, 9	V _{L+}	7		36	V
Supply Voltage Ripple	F _{ripple} = DC ... 100kHz V _{L+} > 12 V	9	ΔV _{L+}			1	V
Voltage CQ	Receiver mode	8	V _{CQ_MAX}	V _{L-}		V _{L+}	V
Logic Level Supply Voltage	External Supply	1	VDD	3		5.5	V
LDO Output Current	3.3V LDO or 5V LDO, V _{L+} ≤ 24V	1	I _{VDD}			20	mA
ILIM External Resistor	To L-	6	R _{ILIM}	0		100	kΩ
LDO External Capacitor	To L-	1	C _{LDO}	0.8	1	1.2	μF

3.3 Electrical Characteristics

Table 5: Input / Output CQ

Parameter	Conditions	Pin	Name	Min	Typ	Max	Unit
Output voltage low level	active pull down, I _{oL} = -200mA	8	V _{oL}	0		1.5	V
Output voltage high level	active pull up, I _{oH} = +200mA	8	V _{oH}	V _{L+} - 1.5		V _{L+}	V
Leakage current	input enabled 0 ≤ V _{CQ} ≤ V _{L+} - 0.1 V	8	I _{leak}	-2		2	μA
Maximum Permanent Output Current	Current of CQ channel	8	I _{CQmax}	-250		250	mA
Output source current limit	R _{ILIM} = 0 or hZ R _{ILIM} = 100 kΩ	8	I _{limP}	300 35	350 50	400 70	mA
Output sink current limit	R _{ILIM} = 0 or hZ R _{ILIM} = 100 kΩ	8	I _{limN}	-400 -70	-350 -50	-300 -35	mA
Load capacitance		8	C _L			5	nF
Inductive load		8	L _{Load}			1.5	H
Output rise/fall time (20% to 80%)	Open load, R _{ILIM} = 0 or hZ	8	t _{r,f}			869	ns
Switch On Time		8	t _{DLY_LH}			4	μs
Switch Off Time		8	t _{DLY_HL}			4	μs
Short circuit detection time		8	T _{SHORT}			300	μs
Short circuit disable time	R _{ILIM} ≠ hZ	8	T _{SHORT_DIS}		15		ms

IO-Link Device IC

Parameter	Conditions	Pin	Name	Min	Typ	Max	Unit
Wake-up detection time		8	T _{WAKE}	40	80	100	μs
Input threshold high level		8	V _{IH}	10.5	11.75	13	V
Input threshold low level		8	V _{IL}	8	9.75	11.5	V
Hysteresis between input thresholds high and low		8	V _{Hyst}		2		V

Table 6: Digital I/O

Parameter	Conditions	Pin	Name	Min	Typ	Max	Unit
Input							
Input Voltage LOW	VDD = 3.3 V	4, 5	V _{IN_L_3V3}			1	V
Input Voltage HIGH	VDD = 3.3 V	4, 5	V _{IN_H_3V3}	2.3			V
Input Voltage LOW	VDD = 5.0 V	4, 5	V _{IN_L_5V}			1.5	V
Input Voltage HIGH	VDD = 5.0 V	4, 5	V _{IN_H_5V}	3.5			V
Input Pull-Up current	VDD - VSS = 5.0 V, V _{pin} =0V	4, 5	I _{PU_5V}	3	30	110	μA
Input Pull-Down current	VDD - VSS = 5.0 V, V _{pin} =5.0V	4, 5	I _{PD_5V}	-110	-30	-3	μA
Output							
Output Voltage LOW	VDD - VSS = 3.3 V I _{OUT_LOW} = 2 mA	2, 3, 10	V _{OUT_L}			0.7	V
	VDD - VSS = 5.0 V I _{OUT_LOW} = 2 mA	2, 3, 10	V _{OUT_L}			0.8	V
Output Voltage HIGH	VDD - VSS = 3.3 V I _{OUT_HIGH} = 2 mA	3	V _{OUT_H}	2.6			V
	VDD - VSS = 5.0 V I _{OUT_HIGH} = 2 mA	3	V _{OUT_H}	4.2			V

IO-Link Device IC

Table 7: 3.3V / 5V Voltage Regulator

Parameter	Conditions	Pin	Name	Min	Typ	Max	Unit
Output Voltage VDD	3.3V Regulator	1	VDD _{3V3}	3.0	3.3	3.6	V
	5V Regulator	1	VDD _{5V}	4.5	5	5.5	V
Voltage Drop	Load Current = 20 mA	1	V _{DO}			2	V
Output Current VDD		1	I _{VDD}			20	mA
Line regulation	I _{OUT} = 1 mA V _{L+} = 24 V	1	REG			2	mV/V
Load regulation	DC current up to 20 mA V _{L+} = 24 V	1				1	%
Power Supply rejection ratio	100 kHz, I _{OUT} = 20 mA	1	PSRR	40			dB
Power-On Threshold	Only applies to the driver without LDO (CCE4503-0)	1	V _{RST}	2.7		3.0	V
Undervoltage lockout voltage (V _{L+})		1	V _{L+,min}		6		V
Undervoltage lockout voltage (V _{DD})		1	V _{DD,min}			3	V
Start-up time		1				5	μs

3.4 Thermal Characteristics

Table 8: Thermal characteristics

Parameter	Description	Conditions	Min	Typ	Max	Unit
T _{ALARM_H}	Alarm temperature (higher threshold)		150	165	180	°C
T _{ALARM_L}	Alarm temperature (lower threshold)		140	155	170	°C
T _{WARNING}	Warning temperature (higher threshold)		125	140	155	°C
R _{tja}	Thermal resistance (junction to ambient)				30	K/W

4 Functional Description

CCE4503 is a fully reverse polarity protected IO-Link slave device with one IO-Link channel. The system consists of a high voltage output stage with integrated overcurrent protection, a high voltage input stage with a spike-tolerant filter, a logic core with UART interface, an internal oscillator and an optional LDO. The LDO output voltage is factory programmed and needs to be specified with the order. To simplify the IO-Link protocol handling, a wake-up detection and automatic recovery function are implemented. Additional advance protection features such as overtemperature detection and undervoltage detection ensure robust functionality in industrial applications. All pins are ESD-protected.

4.1 Output stage

The output stage switches the output transistors in regard to TXD and TXEN. In IO-Link mode or Push-Pull mode TXEN is used to enable or disable the output stage. If TXEN is set high, the output stage is enabled and the output of CQ can be controlled by TXD (inverted). If TXEN is set low, the output stage is disabled and put into an inactive low-power state.

TXEN and TXD can also be used to configure the device in NPN, PNP and Push-Pull mode. See Table 9. NPN mode can be configured by setting TXD high and using TXEN as control pin. PNP mode can be configured by setting TXD low and using TXEN as control pin.

Table 9: Output stage truth table

Mode	TXEN	TXD	CQ
IO-Link (regular operation) / Push-Pull	0	0	High-Z
	0	1	High-Z
	1	0	1
	1	1	0
NPN	0	1	High-Z
	1	1	0
PNP	0	0	High-Z
	1	0	1

IO-Link Device IC

4.2 Current limit and slew rate configuration

The driver slew rate as well as the current limit is configured by a resistor R_{ILIM} connected to ILIM. The value of the resistor intended for configuration is specified between 0Ω and $100\text{ k}\Omega$, where a lower resistor value leads to faster switching and higher maximum currents. The automatic recovery function is only available for $R_{ILIM} < 1\text{ M}\Omega$.

Table 10: Current limit and slew rate configuration

Resistor	Current limit	Slew rate	Automatic recovery
$0\Omega - 100\text{ k}\Omega$	350 mA - 50 mA	Fast - slow	Yes
Open ($R_{ILIM} > 4\text{ M}\Omega$)	350 mA	Fast	No

Note: If ILIM is left open ($R_{ILIM} > 4\text{ M}\Omega$) the output driver operates as if connected to VSS ($R_{ILIM} = 0\Omega$), but with automatic recovery disabled.

4.3 Automatic Recovery

If a short is detected, the output stage is automatically disabled after the time t_{SHORT} . The automatic recovery function enables the output again after t_{SHORT_DIS} and checks if the overcurrent is still present (see Figure 4).

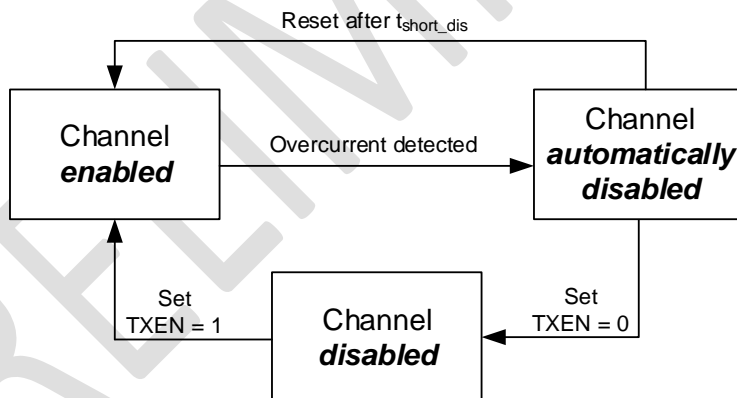

Figure 4: Automatic recovery

4.4 Wake-up detection

An overcurrent pulse of t_{WAKE} will be detected as wake-up pulse. When a wake-up pulse is detected, the output of NWUP will switch from high impedance to low until TXEN is toggled by the microcontroller.

An overcurrent pulse $> t_{WAKE}$ will be detected as overcurrent fault condition.

An overcurrent pulse $< t_{WAKE}$ will not be detected.

IO-Link Device IC

4.5 Error output handling

The error output NERR combines the indication of three error sources and will be tied low if any fault condition is detected. The following error sources are indicated by NERR:

- Overtemperature
- Undervoltage
- Overcurrent

The overtemperature and undervoltage detections are combinational outputs and keep the NERR signal low as long as the error is present. The overcurrent detection is latched and will be reset when the CCE4503 leaves the transmit mode (TXEN = 0).

4.6 Overtemperature detection

The overtemperature detection detects 3 thresholds:

- At T_{WARNING} the output of NERR will be tied low. This is a combinational signal and cannot be reset by the MCU. It will be reset once the temperature drops below T_{WARNING} .
- At $T_{\text{ALARM_H}}$, the chip will switch off the outputs. This cannot be reset by the MCU.
- When the temperature drops again below $T_{\text{ALARM_L}}$, the output is released and can be controlled by TXEN and TXD.

4.7 Allowed Reverse polarity connections

The CCE4503 is designed to handle all possible permutations of reverse polarity.

5 Package Information

5.1 Package Outlines

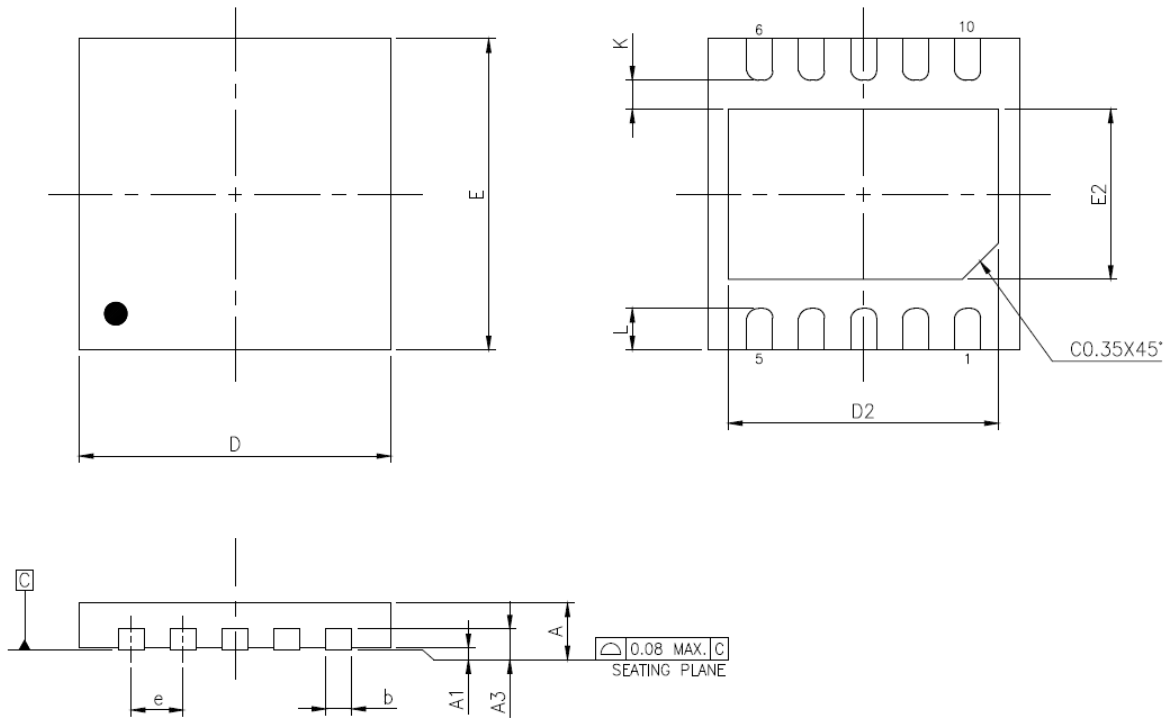

JEDEC OUTLINE	MO-229			PAD SIZE			D2			E2			L			LEAD FINISH		JEDEC CODE	VDFN	WDFN	UDFN
PKG CODE	WDFN(X310)			MIN.	NOM.	MAX.	MIN.	NOM.	MAX.	MIN.	NOM.	MAX.	Pure Tin	PPF	(V)W30300-5	V	V	—			
SYMBOLS	MIN.	NOM.	MAX.	2.20	2.30	2.35	1.55	1.65	1.70	0.30	0.40	0.50	V	V							
A	0.70	0.75	0.80																		
A1	0.00	0.02	0.05																		
A3	0.203	REF.																			
b	0.18	0.25	0.30																		
D	3.00 BSC																				
E	3.00 BSC																				
e	0.50 BSC																				
K	0.20	—	—																		

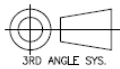

Figure 5: DFN10 Package Outline Drawing

5.2 Soldering Information

Refer to the IPC/JEDEC standard J-STD-020 for relevant soldering information. This document can be downloaded from <http://www.jedec.org>.

6 Ordering Information

The ordering number consists of the part number followed by a suffix (shown as "xxxx") indicating the package, packing method and LDO option. For details and availability, please consult Dialog Semiconductor's [customer support portal](#) or your local sales representative.

Table 11: Ordering Information

Part Number	Package	Size (mm)	Shipment Form	Pack Quantity
CCE4503 xx LDO	DFN10	3 x 3	T&R	4000

Part Number Legend:

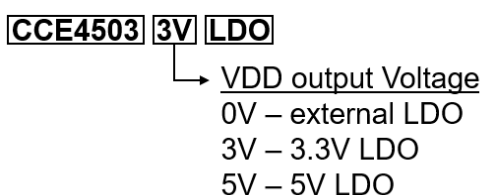

7 Application Information

The CCE4503 may need to be connected to some external components depending on the desired operating environment:

- If an LDO is selected (5V or 3.3V), a 1 μF capacitor from VDD to L- must be provided by the customer
- Outputs NERR and NWUP are open-drain outputs. Usually the internal pull-up resistors of the MCU can be used. If no pull-up resistors can be configured, the customer needs to connect external resistors.
- A resistor RLIM may be used to set the overcurrent limit and slew rate. For maximum slew rate and overcurrent limit, the pin can be connected to VSS or left open.

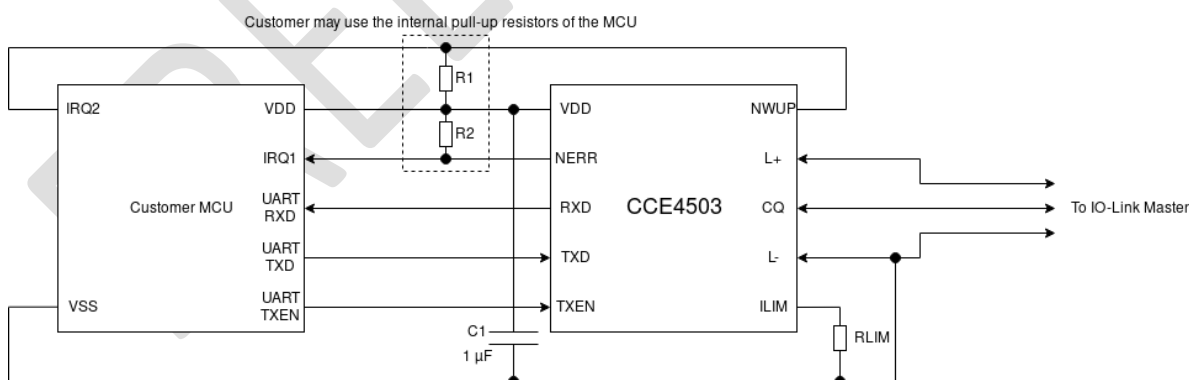

Figure 6: CCE4503 application

IO-Link Device IC

Revision History

Revision	Date	Description
2.3	23-Jul-2020	Changed Ordering Information
2.2	27-May-2020	Corrected Electrical Characteristics (Table 5 & 6)
2.1	26-May-2020	Corrected Electrical Characteristics (Table 6) Added Errata sheet note
2.0	20-Feb-2020	Initial version. Preliminary

Status Definitions

Revision	Datasheet Status	Product Status	Definition
1.<n>	Target	Development	This datasheet contains the design specifications for product development. Specifications may be changed in any manner without notice.
2.<n>	Preliminary	Qualification	This datasheet contains the specifications and preliminary characterization data for products in pre-production. Specifications may be changed at any time without notice in order to improve the design.
3.<n>	Final	Production	This datasheet contains the final specifications for products in volume production. The specifications may be changed at any time in order to improve the design, manufacturing and supply. Major specification changes are communicated via Customer Product Notifications. Datasheet changes are communicated via www.dialog-semiconductor.com .
4.<n>	Obsolete	Archived	This datasheet contains the specifications for discontinued products. The information is provided for reference only.

IO-Link Device IC

Disclaimer

Information in this document is believed to be accurate and reliable. However, Dialog Semiconductor does not give any representations or warranties, expressed or implied, as to the accuracy or completeness of such information. Dialog Semiconductor furthermore takes no responsibility whatsoever for the content in this document if provided by any information source outside of Dialog Semiconductor.

Dialog Semiconductor reserves the right to change without notice the information published in this document, including without limitation the specification and the design of the related semiconductor products, software and applications.

Applications, software, and semiconductor products described in this document are for illustrative purposes only. Dialog Semiconductor makes no representation or warranty that such applications, software and semiconductor products will be suitable for the specified use without further testing or modification. Unless otherwise agreed in writing, such testing or modification is the sole responsibility of the customer and Dialog Semiconductor excludes all liability in this respect.

Customer notes that nothing in this document may be construed as a license for customer to use the Dialog Semiconductor products, software and applications referred to in this document. Such license must be separately sought by customer with Dialog Semiconductor.

All use of Dialog Semiconductor products, software and applications referred to in this document are subject to Dialog Semiconductor's [Standard Terms and Conditions of Sale](#), available on the company website (www.dialog-semiconductor.com) unless otherwise stated.

Dialog and the Dialog logo are trademarks of Dialog Semiconductor plc or its subsidiaries. All other product or service names are the property of their respective owners.

© 2020 Dialog Semiconductor. All rights reserved.

RoHS Compliance

Dialog Semiconductor's suppliers certify that its products are in compliance with the requirements of Directive 2011/65 and 2015/863 / EU of the European Parliament on the restriction of the use of certain hazardous substances in electrical and electronic equipment. RoHS certificates from our suppliers are available on request.

Contacting Dialog Semiconductor

United Kingdom (Headquarters)

Dialog Semiconductor (UK) LTD
Phone: +44 1793 757700

Germany

*Dialog Semiconductor
Creative Chips GmbH*
Phone: +49 6721 98722 0

Email:

enquiry@diasemi.com

North America

Dialog Semiconductor Inc.
Phone: +1 408 845 8500

Japan

Dialog Semiconductor K. K.
Phone: +81 3 5769 5100

Taiwan

Dialog Semiconductor Taiwan
Phone: +886 281 786 222

Web site:

www.dialog-semiconductor.com

Hong Kong

Dialog Semiconductor Hong Kong
Phone: +852 2607 4271

Korea

Dialog Semiconductor Korea
Phone: +82 2 3469 8200

The Netherlands

Dialog Semiconductor B.V.
Phone: +31 73 640 8822

China (Shenzhen)

Dialog Semiconductor China
Phone: +86 755 2981 3669

China (Shanghai)

Dialog Semiconductor China
Phone: +86 21 5424 9058

X-ON Electronics

Largest Supplier of Electrical and Electronic Components

Click to view similar products for [Interface - Specialised category](#):

Click to view products by [Dialog Semiconductor manufacturer](#):

Other Similar products are found below :

[CY7C910-51LMB](#) [MC33689DPEWR2](#) [MC33975ATEKR2](#) [MEC1632-AUE](#) [NVT4555UKZ](#) [RKSAS4](#) [HMC677G32](#) [LPC47N207-JV](#) [FTP-637DSL633R](#) [SM712GX04LF04-BA](#) [MC33689DPEW](#) [PCA9704PWJ](#) [NCN5192MNRG](#) [MCW1001A-I/SS](#) [HOA6241-001](#)
[SC74HC4066ADTR2G](#) [AS3935-BQFT](#) [NCN5120MNTWG](#) [NCN5150DR2G](#) [NCN8025MTTBG](#) [C100N50Z4A](#) [DG407AK/883B](#) [SRT2-ATT01](#) [TDA8035HN/C1/S1J](#) [TLE9221SXXUMA2](#) [DS90UB947TRGCRQ1](#) [SP510ECF-L](#) [NCS2300MUTAG](#) [HMC677LP5E](#)
[HMC677LP5ETR](#) [LTC1756EGN#PBF](#) [LTC1955EUH#PBF](#) [MXL1543BCAI](#) [MAX3170CAI+](#) [XL1192D](#) [ST8024CTR](#) [TLE9221SX](#)
[KTU1109EFAA-TR](#) [CH368L](#) [CH7307C-DEF](#) [LTC1694CS5#TRPBF](#) [LTC1694IS5#TRM](#) [LTS 25-NP](#) [73S8024RN-20IMF](#) [73S8024RN-IL/F](#)
[78P2352-IGT/F](#) [DS2406+](#) [DS2413P+](#) [DS2413P+T&R](#) [DS28E17Q+](#)