

# CLC2622

## LCD Driver

The CLC2622 is a low power CMOS LCD controller driver, designed to drive a graphic display with 2, 4 or 8 rows and 38, 36 or 32 columns in muxed mode or up to 40 segments in static mode. All necessary functions for the display are provided in a single chip, including on-chip generation of the LCD bias voltages, display refresh and FR clock generation, resulting in a minimum of external components.

The large voltage range and a low current consumption makes the driver suitable for a variety of different LCD display. Also large pixel size applications are supported due to the low driver impedance. Several CLC2622 can be easily cascaded, no external resistor bias chain and no external clock is necessary.

### Features

- Selectable static or multiplexing LCD driver
- Integrated dual RAM for display storage
- On chip LCD bias voltage generation, display refresh and internal clock generation
- Selectable synchronize signal generation for large LCD applications
- Available in QFN56 and CSP with gold bumps (size 3.14 x 2.98 mm)

### Benefits

- Flexibility to support a range of LCD displays
- Minimal external components and Chip-on-glass mountable for small system footprint
- Easily cascadable

### Applications

- LCD matrix displays

## Block Diagram

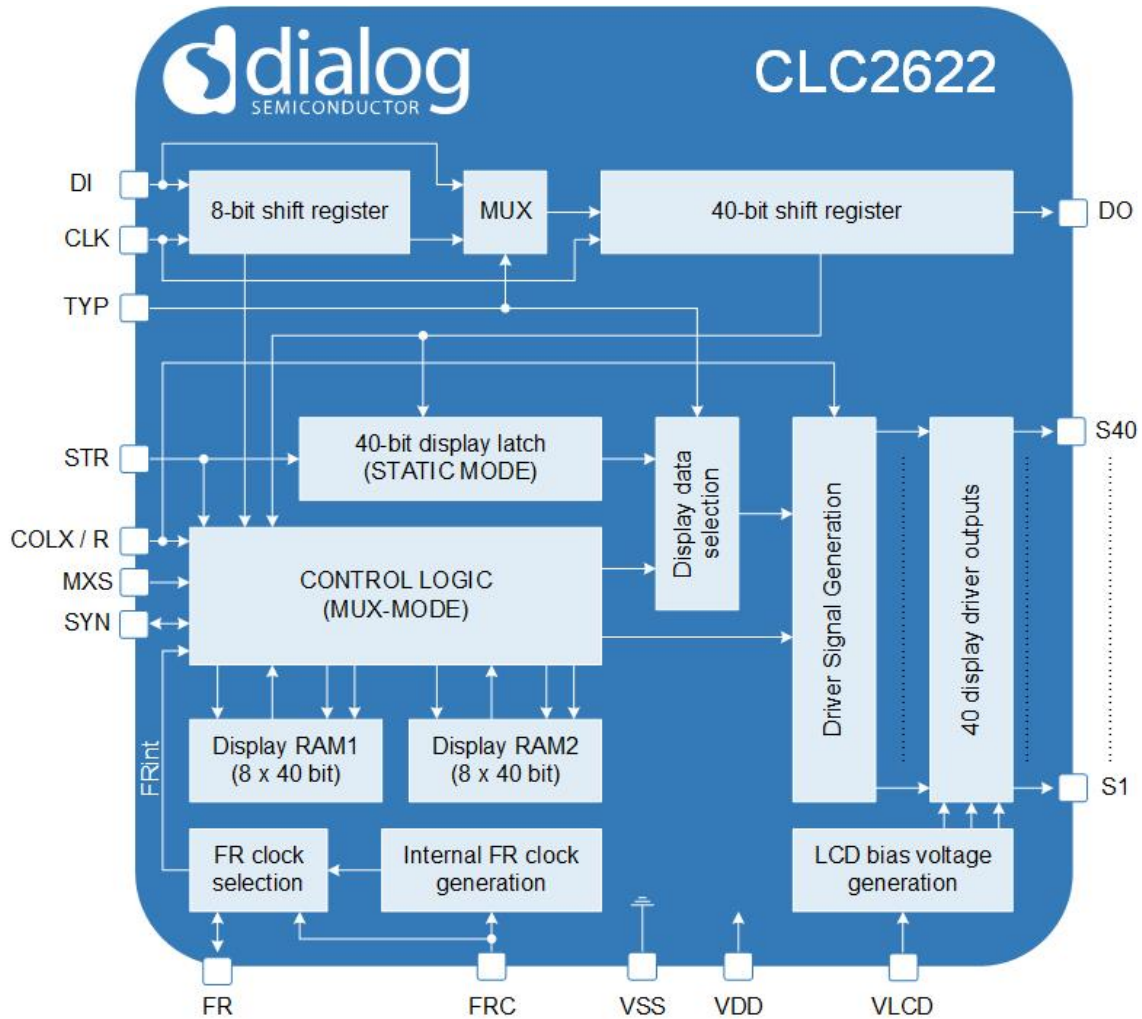

## Dialog Semiconductor Worldwide Sales Offices

[www.dialog-semiconductor.com](http://www.dialog-semiconductor.com) email: [info@diasemi.com](mailto:info@diasemi.com)

**United Kingdom**  
Phone: +44 1793 757700

**The Netherlands**  
Phone: +31 73 640 88 22

**Japan**  
Phone: +81 3 5769 5100

**Singapore**  
Phone: +65 648 499 29

**Korea**  
Phone: +82 2 3469 8200

**Germany**  
Phone: +49 7021 805-0

**North America**  
Phone: +1 408 845 8500

**Taiwan**  
Phone: +886 281 786 222

**Hong Kong**  
Phone: +852 3769 5200

**China (Shenzhen)**  
Phone: +86 755 2981 3669

**China (Shanghai)**  
Phone: +86 21 5424 9058

This publication is issued to provide outline information only, which unless agreed by Dialog Semiconductor may not be used, applied, or reproduced for any purpose or be regarded as a representation relating to products. All use of Dialog Semiconductor products, software and applications referred to in this document are subject to Dialog Semiconductor's Standard Terms and Conditions of Sale, available on the company website ([www.dialogsemiconductor.com](http://www.dialogsemiconductor.com)) unless otherwise stated. Dialog and the Dialog logo are trademarks of Dialog Semiconductor plc or its subsidiaries. All other product or service names are the property of their respective owners. © Copyright 2019 Dialog Semiconductor. All rights reserved.



## X-ON Electronics

Largest Supplier of Electrical and Electronic Components

*Click to view similar products for [Display Drivers & Controllers](#) category:*

*Click to view products by [Dialog Semiconductor](#) manufacturer:*

Other Similar products are found below :

[ICB2FL01G](#) [HV5812PJ-G-M904](#) [TW8813-LB2-GR](#) [TW8811-PC2-GR](#) [MAX1839EEP+](#) [TW9907-TA1-GR](#) [LX27901IDW](#) [SSD2828QN4](#)  
[MAX7370ETG+](#) [DLPA1000YFFT](#) [ICB2FL01GXUMA2](#) [DLP2000FQC](#) [PAD1000YFFR](#) [S1D13746F01A600](#) [FIN324CMLX](#) [AD8387JSVZ](#)  
[DLPC6421ZPC](#) [HV852K7-G](#) [HV859K7-G](#) [HV857K7-G](#) [DIO2133CT14](#) [S1D13L03F00A100-40](#) [TW2836-BA1-GR](#) [SSD2829QL9](#)  
[MAX749CSA+T](#) [MAX4820EUP+T](#) [ICL7135CAI+](#) [ICL7135CMH+D](#) [ICL7137CMH+D](#) [MAX14515AEWA+](#) [MAX14521EETG+](#)  
[MAX25221BATJ/V+](#) [DS3882E+C](#) [S1D13748B00B100](#) [S1D13A05B00B200](#) [MAX3738ETG+T](#) [MAX14514ETD+](#) [MAX4990ETD+T](#)  
[MAX8722CEEG+](#) [MAX749CPA+](#) [MAX8785AETI+](#) [ICL7135CQI+](#) [HV518PJ-G-M903](#) [HV5812P-G](#) [HV5812PJ-G](#) [HV7224PG-G](#)  
[HV853K7-G](#) [HV860K7-G](#) [HV6810WG-G](#) [HV823LG-G](#)