

General description

The DA14681 is a flexible System-on-Chip combining an application processor, memories, cryptography engine, power management unit, digital and analog peripherals and a Bluetooth Low Energy MAC engine and radio transceiver.

The DA14681 is based on an ARM® Cortex®-M0 CPU delivering up to 84 DMIPS and provides a flexible memory architecture, enabling code execution from embedded memory (RAM, ROM) or non-volatile memory (OTP or external Quad-SPI FLASH).

The advanced power management unit of the DA14681 enables it to run from primary and secondary batteries, as well as provide power to external devices. The on-chip charger and state-of-charge fuel gauge allow the DA14681 to natively charge rechargeable batteries over USB.

An on-chip PLL enables on-the-fly tuning of the system clock between 32 kHz and 96 MHz to meet high processing requirements. Several optimised sleep modes are available to reduce power dissipation when there is no activity.

Features

- Complies to *Bluetooth v4.2*, ETSI EN 300 328 and EN 300 440 Class 2 (Europe), FCC CFR47 Part 15 (US) and ARIB STD-T66 (Japan)
- Flexible processing power
 - 0 Hz up to 96 MHz 32-bit ARM Cortex-M0 with 4-way associative cache
 - Three optimised power modes (Extended sleep, Deep sleep and Hibernation) reducing current to 1.4 μ A
- Memories
 - 64 kB One-Time-Programmable (OTP) memory
 - 128 kB Data SRAM with retention capabilities
 - 16 kB Cache SRAM with retention capabilities
 - 128 kB ROM (including boot ROM and BLE stack)
- Power management
 - Integrated Buck DC-DC converter (1.7 V - 4.75 V)
 - Three power supply pins for external devices
 - Supports Li-Polymer, Li-Ion, coin, NiMH and alkaline batteries
- Charger (up to 5.0 V) with programmable curves
- High accuracy state-of-charge fuel gauge
- Programmable threshold for brownout detection
- Digitally controlled oscillators and PLL
 - 16 MHz crystal oscillator
 - 16 MHz RC oscillator
 - 32 kHz crystal and RC oscillator
 - 11.7 kHz RCX oscillator
 - Low power PLL up to 96 MHz
- Three general purpose timer/counters with PWM
 - One 16-bit up/down timer/counter with PWM available in extended/deep sleep mode
- Application cryptographic engine with ECC, AES-256, SHA-1, SHA-256, SHA-512 and True Random Number Generator
- Digital interfaces
 - 37 (AQFN) or 21 (WLCSP) general purpose I/Os with programmable voltage levels
 - Quad-SPI FLASH interface
 - Two UARTs, one with hardware flow control
 - Two SPI+™ interfaces
 - Two I2C bus interfaces at 100 kHz, 400 kHz
 - Three-axes capable Quadrature Decoder
 - PDM + HW decimator (2 mics or 2 speakers)
 - I2S/PCM master/slave interface up to 8 channels
 - Keyboard scanner with debouncing
 - Infrared (IR) interface (PWM)
 - USB 1.1 Full Speed (FS) device interface
- Analog interfaces
 - 8-channel 10-bit ADC with averaging capability
 - Three matched white LED drivers
 - Temperature sensor
- Radio transceiver
 - 2.4 GHz CMOS transceiver with integrated balun
 - 50 Ω matched single wire antenna interface
 - 0 dBm transmit output power
 - -94 dBm receiver sensitivity (BLE)
 - Supply current at VBAT1 (3 V):
 - TX: 3.4 mA
 - RX: 3.1 mA (with ideal DC-DC converter)
- Packages:
 - AQFN with 60 pins, 6 mm x 6 mm
 - WLCSP with 53 balls, 3.406 mm x 3.010 mm

System diagram



1 Block diagram	6	8.2 RUNTIME RECONFIGURATION	58
2 Package and pinout	7	8.2.1 Cache Line reconfiguration	58
3 System overview	19	8.2.2 TAG memory word	58
3.1 INTERNAL BLOCKS	19	8.2.3 Associativity reconfiguration	58
3.2 FUNCTIONAL MODES	20	8.3 2 AND 4 WAY REPLACEMENT STRATEGY .	58
3.3 SYSTEM CONFIGURATION	20	8.4 CACHE RESETS	58
3.4 SYSTEM STARTUP PROCEDURE	23	8.5 CACHE MISS RATE MONITOR	59
3.4.1 Power/Wakeup FSM	24	8.6 CACHE MISS LATENCY AND POWER	59
3.4.2 Goto Sleep FSM	24	9 AMBA Bus	61
3.4.3 BootROM sequence	25	10 Memory Controller	63
3.5 POWER CONTROL AND MODES	27	11 OTP Controller	65
3.5.1 System Power Control	27	11.1 OPERATING MODES	65
3.5.2 Power domains	28	11.2 AHB MASTER INTERFACE	66
3.5.3 Power modes	29	11.3 AHB SLAVE INTERFACES	66
4 Power management	31	11.4 ERROR CORRECTING CODE (ECC)	66
4.1 ARCHITECTURE	31	11.5 BUILD-IN SELF REPAIR (BISR)	66
4.1.1 SIMO DC-DC converter	32	12 Quad SPI Controller	67
4.1.2 LDOs	34	12.1 ARCHITECTURE	67
4.1.3 Switching from DC-DC to LDOs	36	12.1.1 Interface	67
4.1.4 PMU configurations in Sleep modes	37	12.1.2 Initialization FSM	68
4.1.5 Wake/Power up - Sleep Timing	37	12.1.3 SPI modes	69
4.1.6 Charger	40	12.1.4 Access modes	69
4.1.7 Fuel gauge	42	12.1.5 Endianness	69
4.1.8 USB charger detection	44	12.1.6 Erase Suspend/Resume	69
5 Reset	47	12.1.7 QSPI FLASH Programming	70
5.1 POR, HW AND SW RESET	47	12.2 PROGRAMMING	70
5.2 BROWN OUT DETECTION	48	12.2.1 Auto Mode	70
6 Clock generation	49	12.2.2 Manual Mode	71
6.1 CLOCK TREE	49	12.2.3 Clock selection	71
6.2 CRYSTAL OSCILLATORS	50	12.2.4 Received data	71
6.2.1 Frequency control (16 MHz crystal)	50	12.3 TIMING	71
6.2.2 Automated trimming and settling notification	50	13 DMA Controller	73
6.3 RC OSCILLATORS	51	13.1 DMA PERIPHERALS	74
6.3.1 Frequency calibration	52	13.2 INPUT/OUTPUT MULTIPLEXER	74
6.4 PLL	52	13.3 DMA CHANNEL OPERATION	74
7 ARM Cortex M0	53	13.4 DMA ARBITRATION	75
7.1 SYSTEM TIMER (SYSTICK)	54	13.5 FREEZING DMA CHANNELS	75
7.2 WAKEUP INTERRUPT CONTROLLER	54	14 AES/Hash Engine	76
7.3 REFERENCE	54	14.1 DESCRIPTION	76
7.4 INTERRUPTS	55	14.2 ARCHITECTURE	77
8 Cache Controller	57	14.2.1 AES/HASH engine	77
8.1 CACHABLE RANGE	57	14.2.2 AES	77
		14.2.3 Modes	78
		14.2.4 HASH	78

14.3 PROGRAMMING	79	22.1.1 Interface Signals.....	98
15 ECC Engine	82	22.1.2 Channel ACCESS	98
15.1 ARCHITECTURE	82	22.1.3 Channel delay	99
15.1.1 Supported curves.....	83	22.1.4 Clock generation	99
15.1.2 Supported high level algorithms	83	22.1.5 DATA FORMATS	100
15.2 PROGRAMMING	83	22.1.6 IOM mode	101
15.2.1 Example: ECDSA signature generation	83	22.1.7 External synchronisation	101
16 True Random Number Generator (TRNG).....	86	23 UART	103
16.1 ARCHITECTURE	86	23.1 UART (RS232) SERIAL PROTOCOL	104
16.2 PROGRAMMING	86	23.2 IRDA 1.0 SIR PROTOCOL	105
16.2.1 Latency	86	23.3 CLOCK SUPPORT	105
17 Temperature Sensor.....	87	23.4 INTERRUPTS	106
17.1 PROGRAMMING	87	23.5 PROGRAMMABLE THRE INTERRUPT... ..	106
18 Wakeup Timer	88	23.6 SHADOW REGISTERS	108
19 General purpose ADC	89	23.7 DIRECT TEST MODE	108
19.1 ARCHITECTURE	89	24 SPI+ Interface	109
19.2 INPUT CHANNELS AND INPUT SCALE	91	24.1 OPERATION WITHOUT FIFOS	109
19.3 STARTING THE ADC	91	24.2 9 BITS MODE	110
19.4 ADC CONVERSION MODES	91	25 I2C.....	113
19.4.1 Manual Mode	91	25.1 I2C BUS TERMS	113
19.4.2 Continuous Mode	91	25.1.1 Bus Transfer Terms	114
19.5 NON-IDEAL EFFECTS	91	25.2 I2C BEHAVIOUR.....	114
19.6 SAMPLING TIME (SMPL_TIME).....	92	25.2.1 START and STOP Generation	115
19.7 OVERSAMPLING	92	25.2.2 Combined Formats	115
19.8 CHOPPING	93	25.3 I2C PROTOCOLS	115
19.9 OFFSET CALIBRATION	93	25.3.1 START and STOP Conditions	115
19.10 ZERO-SCALE ADJUSTMENT	93	25.3.2 Addressing Slave Protocol.....	115
19.11 COMMON MODE ADJUSTMENT	93	25.3.3 Transmitting and Receiving Protocol ..	116
19.12 INPUT IMPEDANCE, INDUCTANCE AND IN- PUT SETTLING.....	94	25.4 MULTIPLE MASTER ARBITRATION	118
20 Sample rate Converter (SRC).....	95	25.5 CLOCK SYNCHRONIZATION	119
20.1 ARCHITECTURE	95	25.6 OPERATION MODES.....	120
20.1.1 I/O channels.....	95	25.6.1 Slave Mode Operation.....	120
20.1.2 I/O multiplexers	95	25.6.2 Master Mode Operation	122
20.1.3 Input and Output Sample rate conversion 96		25.6.3 Disabling I2C controller	122
20.1.4 SRC conversion modes of operation ..	96	26 InfraRed Generator	123
20.1.5 DMA operation.....	96	26.1 ARCHITECTURE	123
20.1.6 Interrupts	96	26.2 PROGRAMMING	124
20.1.7 SRC use cases	96	27 Quadrature Decoder	125
21 PDM interface	97	27.1 ARCHITECTURE	125
22 PCM Controller	98	27.2 PROGRAMMING	125
22.1 ARCHITECTURE	98	28 Keyboard Scanner.....	126
		28.1 ARCHITECTURE	126
		28.2 PROGRAMMING	128

29 Software Timers	129	33.3 DIAGNOSTIC SIGNALS	156
29.1 TIMER0	129	33.4 POWER PROFILE	157
29.2 TIMER1	131	33.4.1 Advertising Event	157
29.3 TIMER2	132	33.4.2 Connection Event	158
29.4 BRTH_TIMER	134	34 CoEx interface	159
30 Watchdog Timer	135	34.1 ARCHITECTURE	159
31 USB Interface	136	34.2 PROGRAMMING	159
31.1 SERIAL INTERFACE ENGINE	137	35 Radio	161
31.2 ENDPOINT PIPE CONTROLLER (EPC) ..	137	35.1 ARCHITECTURE	161
31.3 FUNCTIONAL STATES	138	35.1.1 Receiver	161
31.3.1 Line Condition Detection	138	35.1.2 Synthesizer	161
31.4 FUNCTIONAL STATE DIAGRAM	139	35.1.3 Transmitter	162
31.5 ADDRESS DETECTION	141	35.1.4 RFIO	162
31.6 TRANSMIT AND RECEIVE ENDPOINT FIFOS	142	35.1.5 Biassing	162
142		35.1.6 Control	162
31.7 BIDIRECTIONAL CONTROL ENDPOINT FIFO0	143	35.2 DYNAMIC CONTROLLED FUNCTIONS ..	162
143		35.3 DIAGNOSTIC SIGNALS	162
31.8 TRANSMIT ENDPOINT FIFO (TXFIFO1 TO		36 Memory map	164
TXFIFO5)	145	37 Registers	166
31.9 RECEIVE ENDPOINT FIFO (RXFIFO2 TO		37.1 OTPC REGISTER FILE	168
RXFIFO6)	145	37.2 QSPIC REGISTER FILE	175
31.10 INTERRUPT HIERARCHY	146	37.3 BLE REGISTER FILE	186
31.11 USB POWER SAVING MODES	148	37.4 AES_HASH REGISTER FILE	205
31.11.1 Freezing USB node	148	37.5 CACHE REGISTER FILE	209
31.11.2 Integrated resistors	148	37.6 CRG REGISTER FILE	213
32 Input/Output ports	149	37.7 DCDC REGISTER FILE	223
32.1 PROGRAMMABLE PIN ASSIGNMENT ...	149	37.8 WAKEUP REGISTER FILE	233
32.2 GENERAL PURPOSE PORT REGISTERS	149	37.9 TIMER1 REGISTER FILE	236
32.2.1 Port Data Register	149	37.10 UART REGISTER FILE	239
32.2.2 Port Set Data Output Register	150	37.11 SPI REGISTER FILE	277
32.2.3 Port Reset Data Output Register	150	37.12 I2C REGISTER FILE	282
32.3 FIXED ASSIGNMENT FUNCTIONALITY ..	150	37.13 KEYBOARD SCAN REGISTER FILE ...	316
32.4 STATE RETENTION WHILE SLEEPING ..	150	37.14 IR REGISTER FILE	324
32.5 SPECIAL I/O CONSIDERATIONS	151	37.15 USB REGISTER FILE	327
33 BLE Core	152	37.16 GPADC REGISTER FILE	359
33.1 ARCHITECTURE	152	37.17 QUADRATURE DECODER REGISTER FILE.	362
33.1.1 Exchange Memory	152	37.18 ANAMISC REGISTER FILE	363
33.2 PROGRAMMING	152	37.19 CRG REGISTER FILE	371
33.2.1 Wake up IRQ	152	37.20 COEX REGISTER FILE	373
33.2.2 Switch from Active Mode to Deep Sleep		37.21 GPIO REGISTER FILE	381
Mode	153	37.22 WDOG REGISTER FILE	398
33.2.3 Switch from Deep Sleep Mode to Active		37.23 VERSION REGISTER FILE	399
Mode	153	37.24 GPREG REGISTER FILE	400
33.2.4 Switching on at anchor points	153	37.25 TIMER0/2 AND BREATH REGISTER FILE	404
33.2.5 Switching on due to an external event.	155		

37.26 DMA REGISTER FILE	407
37.27 APU REGISTER FILE	427
37.28 TRNG REGISTER FILE	433
37.29 ELLIPTIC CURVE CONTROLLER REGISTER FILE.....	434
38 Specifications	438
39 Package information.....	456
39.1 MOISTURE SENSITIVITY LEVEL (MSL) ..	456
39.2 WLCSP HANDLING	456
39.3 SOLDERING INFORMATION	456
39.4 PACKAGE OUTLINES	457

1 Block diagram

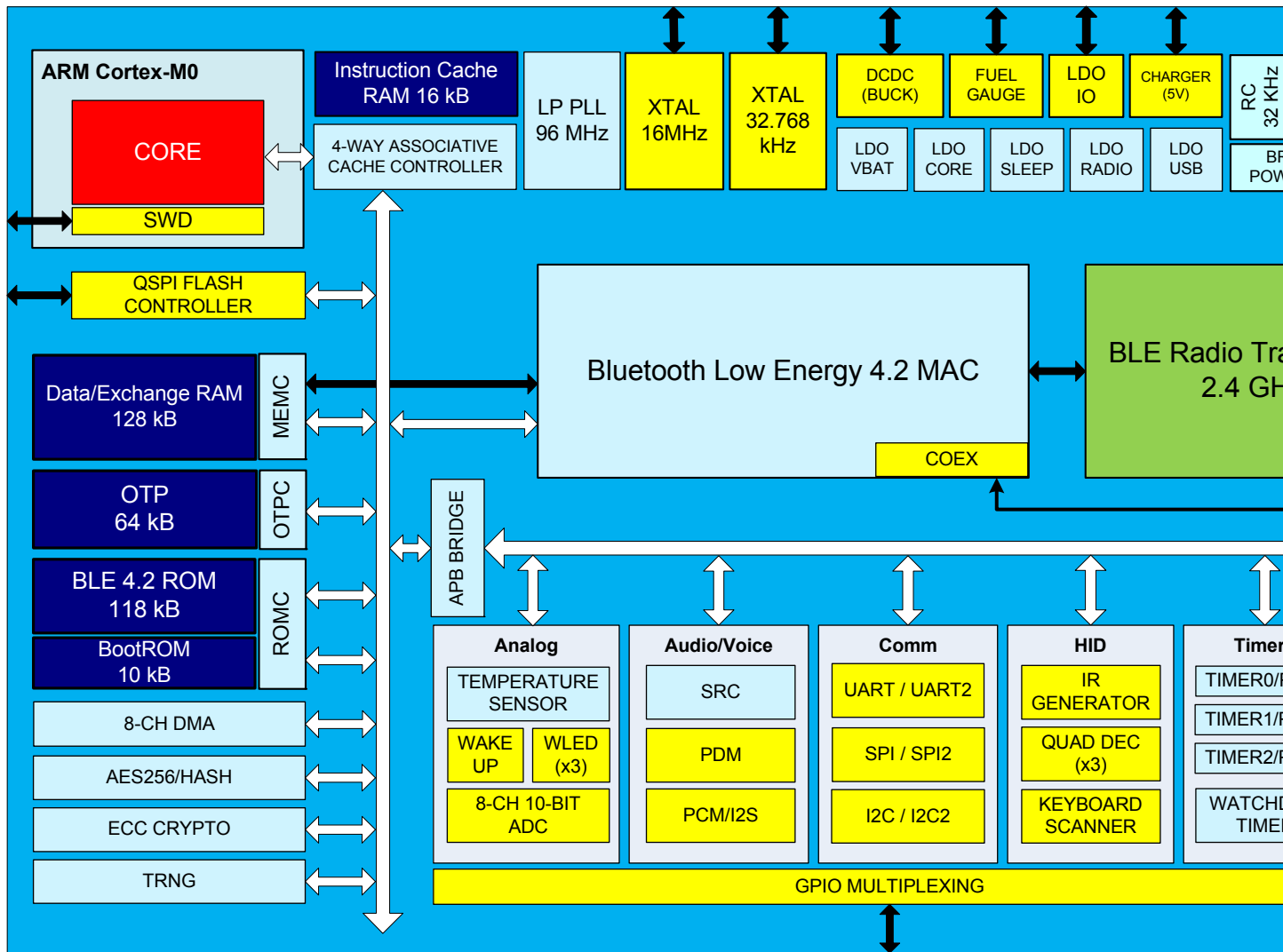

Figure 1: DA14681 block diagram

2 Package and pinout

The DA14681 comes in a 6 mm x 6 mm aQFN package with 60 pins and a WLCSP package with 53 balls. Pins P3x, P4x, LED2 and LED3 are not available in the WLCSP package. The pin/ball assignment is shown in the following figures.

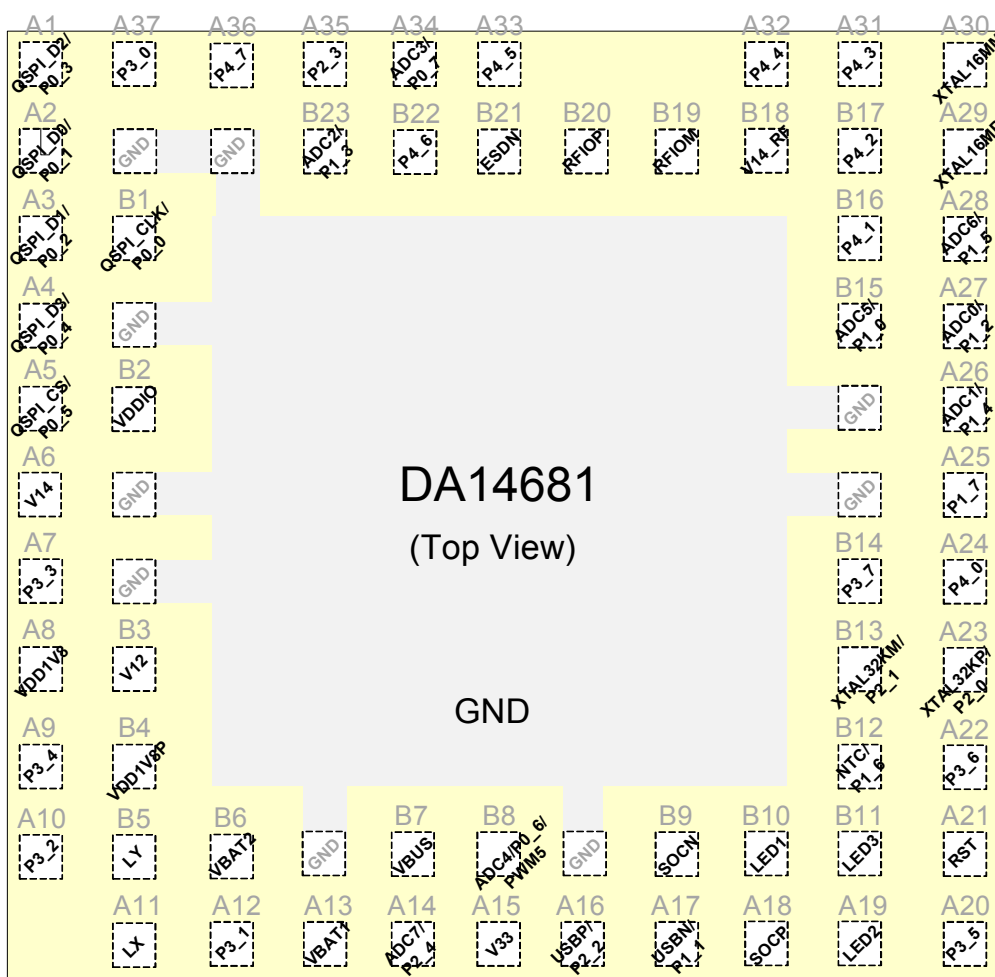

Figure 2: aQFN60 pin assignment

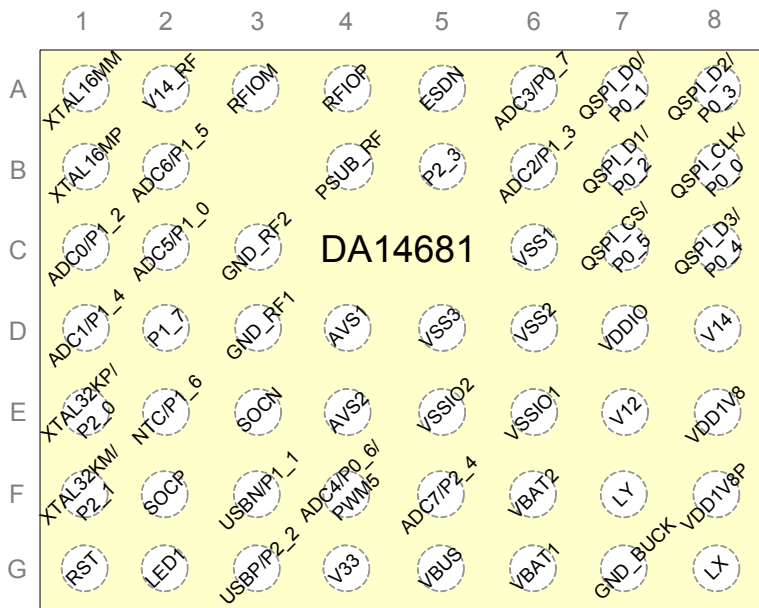

Figure 3: WLCSP53 ball assignment

Table 1: Ordering information

Part number	Package	Size (mm)	Shipment form	Pack quantity
DA14681-01000U22	WLCSP53	3.406 x 3.010	Reel	100/1000 (samples) 5000 (production)
DA14681-01000A92	AQFN60	6 x 6	Reel	100/1000 (samples) 4000 (production)

Table 2: Pin description

Pin no. AQFN	Pin no. WLCSP	Pin name	Type	Drive (mA)	Reset state	Description
General Purpose I/Os (fixed pin assignment; additional functions are programmable via Pxx_MODE_REG)						
B1	B8	P0_0/ QSPI_CLK	DIO DO	4.8	I-PD	INPUT/OUTPUT with selectable pull up/down resistor and open drain functionality. Pull-down enabled during and after reset. General purpose I/O port bit or alternate function nodes. Contains state retention mechanism during power down. OUTPUT. QSPI clock.
A2	A7	P0_1/ QSPI_D0	DIO DIO	4.8	I-PD	INPUT/OUTPUT with selectable pull up/down resistor and open drain functionality. Pull-down enabled during and after reset. General purpose I/O port bit or alternate function nodes. Contains state retention mechanism during power down. INPUT/OUTPUT. QSPI data I/O 0.
A3	B7	P0_2/ QSPI_D1	DIO DIO	4.8	I-PD	INPUT/OUTPUT with selectable pull up/down resistor and open drain functionality. Pull-down enabled during and after reset. General purpose I/O port bit or alternate function nodes. Contains state retention mechanism during power down. INPUT/OUTPUT. QSPI data I/O 1.
A1	A8	P0_3/ QSPI_D2	DIO DIO	4.8	I-PD	INPUT/OUTPUT with selectable pull up/down resistor and open drain functionality. Pull-down enabled during and after reset. General purpose I/O port bit or alternate function nodes. Contains state retention mechanism during power down. INPUT/OUTPUT. QSPI data I/O 2.
A4	C8	P0_4/ QSPI_D3	DIO DIO	4.8	I-PD	INPUT/OUTPUT with selectable pull up/down resistor and open drain functionality. Pull-down enabled during and after reset. General purpose I/O port bit or alternate function nodes. Contains state retention mechanism during power down. INPUT/OUTPUT. QSPI data I/O 3.
A5	C7	P0_5/ QSPI_CS	DIO DO	4.8	I-PU	INPUT/OUTPUT with selectable pull up/down resistor and open drain functionality. Pull-down enabled during and after reset. General purpose I/O port bit or alternate function nodes. Contains state retention mechanism during power down. OUTPUT. QSPI chip select (active LOW).
B8	F4	P0_6/ SWDIO/ PWM5/ BANDGAP_E NABLE ADC4	DIO DIO DO DO AI	4.8	I-PD	INPUT/OUTPUT with selectable pull up/down resistor and open drain functionality. Pull-down enabled during and after reset. General purpose I/O port bit or alternate function nodes. State retention during power down. INPUT/OUTPUT. JTAG data I/O signal. Note: This is the only pin with output capability in Extended Sleep mode. Minimum 1V VDD required to drive this pin while in Extended Sleep. OUTPUT. Timer 1 PWM output (PWM5) in Sleep mode. OUTPUT. Internal BANDGAP_ENABLE signal indicating the sleep time in detail INPUT. Analog input for ADC channel 4.

Table 2: Pin description

Pin no. AQFN	Pin no. WLCSP	Pin name	Type	Drive (mA)	Reset state	Description
A34	A6	P0_7/ ADC3	DIO AI	4.8	I-PD	INPUT/OUTPUT with selectable pull up/down resistor and open drain functionality. Pull-down enabled during and after reset. General purpose I/O port bit or alternate function nodes. Contains state retention mechanism during power down. INPUT. Analog input for ADC channel 3.
B15	C2	P1_0/ ADC5	DIO AI	4.8	I-PD	INPUT/OUTPUT with selectable pull up/down resistor and open drain functionality. Pull-down/up enabled during and after reset. General purpose I/O port bit or alternate function nodes. State retention during power down. INPUT. Analog input for ADC channel 5.
A17	F3	P1_1/ USBN	DIO AIO	4.8	I-PD	INPUT/OUTPUT with selectable pull up/down resistor and open drain functionality. Pull-down enabled during and after reset. General purpose I/O port bit or alternate function nodes. State retention during power down. Note: to use this pin in GPIO mode USBPAD_REG[USBPAD_EN] must be set. Must be used in V33 supply only. INPUT/OUTPUT. Analog USB Full Speed D- signal.
A27	C1	P1_2/ ADC0	DIO AI	4.8	I-PD	INPUT/OUTPUT with selectable pull up/down resistor and open drain functionality. Pull-down/up enabled during and after reset. General purpose I/O port bit or alternate function nodes. State retention during power down. INPUT. Analog input for ADC channel 0.
B23	B6	P1_3/ ADC2	DIO AI	4.8	I-PD	INPUT/OUTPUT with selectable pull up/down resistor and open drain functionality. Pull-down/up enabled during and after reset. General purpose I/O port bit or alternate function nodes. State retention during power down. INPUT. Analog input for ADC channel 2.
A26	D1	P1_4/ ADC1	DIO AI	4.8	I-PD	INPUT/OUTPUT with selectable pull up/down resistor and open drain functionality. Pull-down/up enabled during and after reset. General purpose I/O port bit or alternate function nodes. State retention during power down. INPUT. Analog input for ADC channel 1.
A28	B2	P1_5/ ADC6	DIO AI	4.8	I-PU	INPUT/OUTPUT with selectable pull up/down resistor and open drain functionality. Pull-down/up enabled during and after reset. General purpose I/O port bit or alternate function nodes. State retention during power down. INPUT. Analog input for ADC channel 6.
B12	E2	P1_6/ NTC	DIO AI	4.8	I-PU	INPUT/OUTPUT with selectable pull up/down resistor and open drain functionality. Pull-up enabled during and after reset. General purpose I/O port bit or alternate function nodes. State retention during power down. INPUT. Analog input for external NTC resistor for battery temperature sensing.
A25	D2	P1_7	DIO	4.8	I-PD	INPUT/OUTPUT with selectable pull up/down resistor and open drain functionality. Pull-down enabled during and after reset. General purpose I/O port bit or alternate function nodes. State retention during power down.

Table 2: Pin description

Pin no. AQFN	Pin no. WLCSP	Pin name	Type	Drive (mA)	Reset state	Description
A23	E1	P2_0/ XTAL32KP	DIO AI DI	4.8	I-PD	INPUT/OUTPUT with selectable pull up/down resistor and open drain functionality. Pull-down enabled during and after reset. General purpose I/O port bit or alternate function nodes. State retention during power down. INPUT. Analog input of the XTAL32K crystal oscillator. INPUT. Digital input for an external clock (square wave).
B13	F1	P2_1/ XTAL32KM	DIO AO	4.8	I-PD	INPUT/OUTPUT with selectable pull up/down resistor and open drain functionality. Pull-down enabled during and after reset. General purpose I/O port bit or alternate function nodes. State retention during power down. OUTPUT. Analog output of the XTAL32K crystal oscillator.
A16	G3	P2_2/ USBP	DIO AIO	4.8	I-PD	INPUT/OUTPUT with selectable pull up/down resistor and open drain functionality. Pull-down enabled during and after reset. General purpose I/O port bit or alternate function nodes. State retention during power down. Note: to use this pin in GPIO mode USBPAD_REG[USBPAD_EN] must be set. Must be used in V33 supply only. INPUT/OUTPUT. Analog USB Full Speed D+ signal.
A35	B5	P2_3	DIO	4.8	I-PD	INPUT/OUTPUT with selectable pull up/down resistor and open drain functionality. Pull-down enabled during and after reset. General purpose I/O port bit or alternate function nodes. State retention during power down.
A14	F5	P2_4/ SWCLK/ ADC7	DIO DI AI	4.8	I-PD	INPUT/OUTPUT with selectable pull up/down resistor and open drain functionality. Pull-down enabled during and after reset. General purpose I/O port bit or alternate function nodes. State retention during power down. INPUT. JTAG clock signal. INPUT. Analog input for ADC channel 7.
A37	N/A	P3_0	DIO	4.8	I-PD	INPUT/OUTPUT with selectable pull up/down resistor and open drain functionality. Pull-down enabled during and after reset. General purpose I/O port bit or alternate function nodes. State retention during power down.
A12	N/A	P3_1	DIO	4.8	I-PD	INPUT/OUTPUT with selectable pull up/down resistor and open drain functionality. Pull-down enabled during and after reset. General purpose I/O port bit or alternate function nodes. State retention during power down.
A10	N/A	P3_2	DIO	4.8	I-PD	INPUT/OUTPUT with selectable pull up/down resistor and open drain functionality. Pull-down enabled during and after reset. General purpose I/O port bit or alternate function nodes. State retention during power down.
A7	N/A	P3_3	DIO	4.8	I-PD	INPUT/OUTPUT with selectable pull up/down resistor and open drain functionality. Pull-down enabled during and after reset. General purpose I/O port bit or alternate function nodes. State retention during power down.
A9	N/A	P3_4	DIO	4.8	I-PD	INPUT/OUTPUT with selectable pull up/down resistor and open drain functionality. Pull-down enabled during and after reset. General purpose I/O port bit or alternate function nodes. State retention during power down.

Table 2: Pin description

Pin no. AQFN	Pin no. WLCSP	Pin name	Type	Drive (mA)	Reset state	Description
A20	N/A	P3_5	DIO	4.8	I-PD	INPUT/OUTPUT with selectable pull up/down resistor and open drain functionality. Pull-down enabled during and after reset. General purpose I/O port bit or alternate function nodes. State retention during power down.
A22	N/A	P3_6	DIO	4.8	I-PD	INPUT/OUTPUT with selectable pull up/down resistor and open drain functionality. Pull-down enabled during and after reset. General purpose I/O port bit or alternate function nodes. State retention during power down.
B14	N/A	P3_7	DIO	4.8	I-PD	INPUT/OUTPUT with selectable pull up/down resistor and open drain functionality. Pull-down enabled during and after reset. General purpose I/O port bit or alternate function nodes. State retention during power down.
A24	N/A	P4_0	DIO	4.8	I-PD	INPUT/OUTPUT with selectable pull up/down resistor and open drain functionality. Pull-down enabled during and after reset. General purpose I/O port bit or alternate function nodes. State retention during power down.
B16	N/A	P4_1	DIO	4.8	I-PD	INPUT/OUTPUT with selectable pull up/down resistor and open drain functionality. Pull-down enabled during and after reset. General purpose I/O port bit or alternate function nodes. State retention during power down.
B17	N/A	P4_2	DIO	4.8	I-PD	INPUT/OUTPUT with selectable pull up/down resistor and open drain functionality. Pull-down enabled during and after reset. General purpose I/O port bit or alternate function nodes. State retention during power down.
A31	N/A	P4_3	DIO	4.8	I-PD	INPUT/OUTPUT with selectable pull up/down resistor and open drain functionality. Pull-down enabled during and after reset. General purpose I/O port bit or alternate function nodes. State retention during power down.
A32	N/A	P4_4	DIO	4.8	I-PD	INPUT/OUTPUT with selectable pull up/down resistor and open drain functionality. Pull-down enabled during and after reset. General purpose I/O port bit or alternate function nodes. State retention during power down.
A33	N/A	P4_5	DIO	4.8	I-PD	INPUT/OUTPUT with selectable pull up/down resistor and open drain functionality. Pull-down enabled during and after reset. General purpose I/O port bit or alternate function nodes. State retention during power down.
B22	N/A	P4_6	DIO	4.8	I-PD	INPUT/OUTPUT with selectable pull up/down resistor and open drain functionality. Pull-down enabled during and after reset. General purpose I/O port bit or alternate function nodes. State retention during power down.
A36	N/A	P4_7	DIO	4.8	I-PD	INPUT/OUTPUT with selectable pull up/down resistor and open drain functionality. Pull-down enabled during and after reset. General purpose I/O port bit or alternate function nodes. State retention during power down.
Debug interface						
B8	F4	SWDIO	DIO	4.8	I-PD	INPUT/OUTPUT. JTAG Data input/output. Bidirectional data and control communication. Mapped on P0_6.
A14	F5	SW_CLK	DIO	4.8	I-PD	INPUT JTAG clock signal. Mapped on P2_4.
Clocks						
A29	B1	XTAL16MP	AI			INPUT. Crystal input for the 16 MHz XTAL oscillator.
A30	A1	XTAL16MM	AO			OUTPUT. Crystal output for the 16 MHz XTAL oscillator.

Table 2: Pin description

Pin no. AQFN	Pin no. WLCSP	Pin name	Type	Drive (mA)	Reset state	Description
A23	E1	XTAL32KP	AI			INPUT. Crystal input for the 32.768 kHz XTAL oscillator. Mapped on P2_0.
B13	F1	XTAL32KM	AO			OUTPUT. Crystal output for the 32.768 kHz XTAL oscillator. Mapped on P2_1.
QSPI interface						
B1	B8	QSPI_CLK	DIO			OUTPUT. QSPI clock. Mapped on P0_0.
A5	C7	QSPI_CS	DIO			OUTPUT. QSPI chip select (active LOW). Mapped on P0_5.
A2	A7	QSPI_D0	DIO			INPUT/OUTPUT. QSPI data 0. Mapped on P0_1.
A3	B7	QSPI_D1	DIO			INPUT/OUTPUT. QSPI data 1. Mapped on P0_2.
A1	A8	QSPI_D2	DIO			INPUT/OUTPUT. QSPI data 2. Mapped on P0_3.
A4	C8	QSPI_D3	DIO			INPUT/OUTPUT. QSPI data 3. Mapped on P0_0.
Quadrature decoder (mapped on port Px_y)						
		QD_CHA_X	DI			INPUT. Channel A for the X axis.
		QD_CHB_X	DI			INPUT. Channel B for the X axis.
		QD_CHA_Y	DI			INPUT. Channel A for the Y axis.
		QD_CHB_Y	DI			INPUT. Channel B for the Y axis.
		QD_CHA_Z	DI			INPUT. Channel A for the Z axis.
		QD_CHB_Z	DI			INPUT. Channel B for the Z axis.
SPI bus interface (mapped on port Px_y)						
		SPI_CLK	DIO			INPUT/OUTPUT. SPI clock.
		SPI_DI	DI			INPUT. SPI data input.
		SPI_DO	DO			OUTPUT. SPI data output.
		SPI_EN	DI			INPUT. SPI clock enable.
		SPI2_CLK	DIO			INPUT/OUTPUT. SPI 2 clock.
		SPI2_DI	DI			INPUT. SPI 2 data input.
		SPI2_DO	DO			OUTPUT. SPI 2 data output.
		SPI2_EN	DI			INPUT. SPI 2 clock enable.
I2C bus interface (mapped on port Px_y)						
		SDA	DIO/DIOD			INPUT/OUTPUT. I2C bus data with open drain port.
		SCL	DIO/DIOD			INPUT/OUTPUT. I2C bus clock with open drain port. Supports bit stretching by a slave in open drain mode.
		SDA2	DIO/DIOD			INPUT/OUTPUT. I2C bus 2 data with open drain port.
		SCL2	DIO/DIOD			INPUT/OUTPUT. I2C bus 2 clock with open drain port. Supports bit stretching by a slave in open drain mode.
UART interface (mapped on port Px_y)						
		UTX	DO			OUTPUT. UART transmit data.
		URX	DI			INPUT. UART receive data.
		UTX2	DO			OUTPUT. UART 2 transmit data.
		URX2	DI			INPUT. UART 2 receive data.
		URTS2	DO			OUTPUT. UART 2 request to send.

Table 2: Pin description

Pin no. AQFN	Pin no. WLCSP	Pin name	Type	Drive (mA)	Reset state	Description
		UCTS2	DI			INPUT. UART 2 clear to send.
Infrared (IR) interface (mapped on port Px_y)						
		IR_OUT	DO			OUTPUT. Infrared data.
Keyboard scanner interface (mapped on port Px_y)						
		KSC_ROWx	DO			OUTPUT. Keyboard rows driven by the scanner.
		KSC_COLx	DI			INPUT. Keyboard columns sampled by the scanner.
PDM interface (mapped on port Px_y)						
		PDM_CLK	DO			OUTPUT. PDM clock output.
		PDM_DATA	DIO			INPUT/OUTPUT. PDM data.

Table 2: Pin description

Pin no. AQFN	Pin no. WLCSP	Pin name	Type	Drive (mA)	Reset state	Description
PCM interface (mapped on port Px_y)						
		PCM_DO	DO			OUTPUT. PCM data output.
		PCM_DI	DI			INPUT. PCM data input.
		PCM_CLK	DIO			INPUT/OUTPUT. PCM bus clock.
		PCM_FSC	DIO			INPUT/OUTPUT. PCM frame sync.
PWM interface (mapped on port Px_y)						
		PWM0	DO			OUTPUT. Pulse Width Modulated output of Timer 0.
		PWM1	DO			OUTPUT. Pulse Width Modulated output of Timer 0.
		PWM2	DO			OUTPUT. Pulse Width Modulated output of Timer 2.
		PWM3	DO			OUTPUT. Pulse Width Modulated output of Timer 2.
		PWM4	DO			OUTPUT. Pulse Width Modulated output of Timer 2.
B8	F4	PWM5	DO			OUTPUT. Pulse Width Modulated output of Timer 1. Mapped on P0_6 in Sleep mode.
Analog interface						
A27	C1	ADC0	AI			INPUT. Analog to Digital Converter input 0. Mapped on P1_2.
A26	D1	ADC1	AI			INPUT. Analog to Digital Converter input 1. Mapped on P1_4.
B23	B6	ADC2	AI			INPUT. Analog to Digital Converter input 2. Mapped on P1_3.
A34	A6	ADC3	AI			INPUT. Analog to Digital Converter input 3. Mapped on P0_7.
B8	F4	ADC4	AI			INPUT. Analog to Digital Converter input 4. Mapped on P0_6.
B15	C2	ADC5	AI			INPUT. Analog to Digital Converter input 5. Mapped on P1_0.
A28	B2	ADC6	AI			INPUT. Analog to Digital Converter input 6. Mapped on P1_5.
A14	F5	ADC7	AI			INPUT. Analog to Digital Converter input 7. Mapped on P2_4.
USB FS interface						
A16	G3	USBP	AIO			INPUT/OUTPUT. Analog USB Full/Low speed D+ signal. Mapped to P2_2.
A17	F3	USBN	AIO			INPUT/OUTPUT. Analog USB Full/Low speed D- signal. Mapped to P1_1.
Radio transceiver						
B20	A4	RFIOP	AIO			RF input/output. Impedance 50 Ω.
B19	A3	RFIOM	AIO			RF ground.
Miscellaneous						
A21	G1	RST	DI			INPUT. Reset signal (active HIGH).
B10	G2	LED1	AO			White LED driver output 1 (open drain, 20 mA maximum).
A19	N/A	LED2	AO			White LED driver output 2 (open drain, 20 mA maximum).

Table 2: Pin description

Pin no. AQFN	Pin no. WLCSP	Pin name	Type	Drive (mA)	Reset state	Description
B11	N/A	LED3	AO			White LED driver output 3 (open drain, 20 mA maximum).
A18	F2	SOCP	AIO			Battery fuel gauge input.
B9	E3	SOCN	AIO			Battery fuel gauge ground. Connect as star point.
Power supply						
A13	G6	VBAT1	AI			INPUT. Battery connection 1 for LDO supply.
B6	F6	VBAT2	AI			INPUT. Battery connection 2 for DC-DC converter supply.
B7	G5	VBUS	AI AI			INPUT. USB bus voltage. INPUT. Battery charge voltage.
B18	A2	V14_RF	AI			INPUT. Radio supply voltage. Connect to V14 externally. 4.7 μ F decoupling capacitor required.
A11	G8	LX	AIO			INPUT/OUTPUT. Connection for the external DC-DC converter inductor.
B5	F7	LY	AIO			INPUT/OUTPUT. Connection for the external DC-DC converter inductor.
A15	G4	V33	AO			OUTPUT. 3.3 V power rail. Maximum current 100 mA.
A6	D8	V14	AO			OUTPUT. 1.4 V power rail. Maximum current 20 mA. 4.7 μ F decoupling capacitor required.
B3	E7	V12	AO			OUTPUT. 1.2 V power rail. Maximum current 50 mA.
A8	E8	VDD1V8	AO			OUTPUT. 1.8 V power rail. Maximum current 75 mA.
B4	F8	VDD1V8P	AO			OUTPUT. 1.8 V power rail. Maximum current 75 mA.
B2	D7	VDDIO	AI			INPUT. FLASH interface supply voltage (1.8 V to 3.3 V). 1 μ F ceramic decoupling capacitor required.
N/A	B4	PSUB_RF	-			Connect to ground.
N/A	C3	GND_RF2	-			Connect to ground.
N/A	C6	VSS1	-			Connect to ground.
N/A	D3	GND_RF1	-			Connect to ground.
N/A	D4	AVS1	-			Connect to ground.
N/A	D5	VSS3	-			Connect to ground.
N/A	D6	VSS2	-			Connect to ground.
N/A	E4	AVS2	-			Connect to ground.
N/A	E5	VSSIO2	-			Connect to ground.
N/A	E6	VSSIO1	-			Connect to ground.
N/A	G7	GND_BUCK	-			Connect to ground.
B21	A5	ESDN	-			Connect to ground.
die pad	N/A	GND	-			Common ground plane for radio, analog and digital circuits.
Unconnected pins						
A1, A2, A3, A4, A5, B1	N/A	NC				Internally not connected. Leave open or connect to ground.

Table 3: Pin type definitions

<p>Digital PADS for GPIO w/wo analog</p>	<p>Digital/analog PAD I/O configurations:</p> <p>DO: Digital Output DI: Digital Input DIO: Digital Input/Output</p> <p>DIOD: Digital Input/Output open drain AI: Analog input AO: Analog Output AIO: Analog Input/Output</p> <p>Pullup/pulldown extensions:</p> <p>PU: Fixed pull-up resistor PD: Fixed pull-down resistor SPU: Switchable pull-up resistor SPD: Switchable pull-down resistor</p> <p>VDDIO_xxx PAD supports 1.8 V or 3.3 V BP = Back drive protected up to 3.45 V</p>
<p>Digital PADS for USB PHY with GPIO</p>	<p>Digital PADS for QSPI</p>
<p>PAD A1</p>	<p>PAD A2</p>

Table 3: Pin type definitions

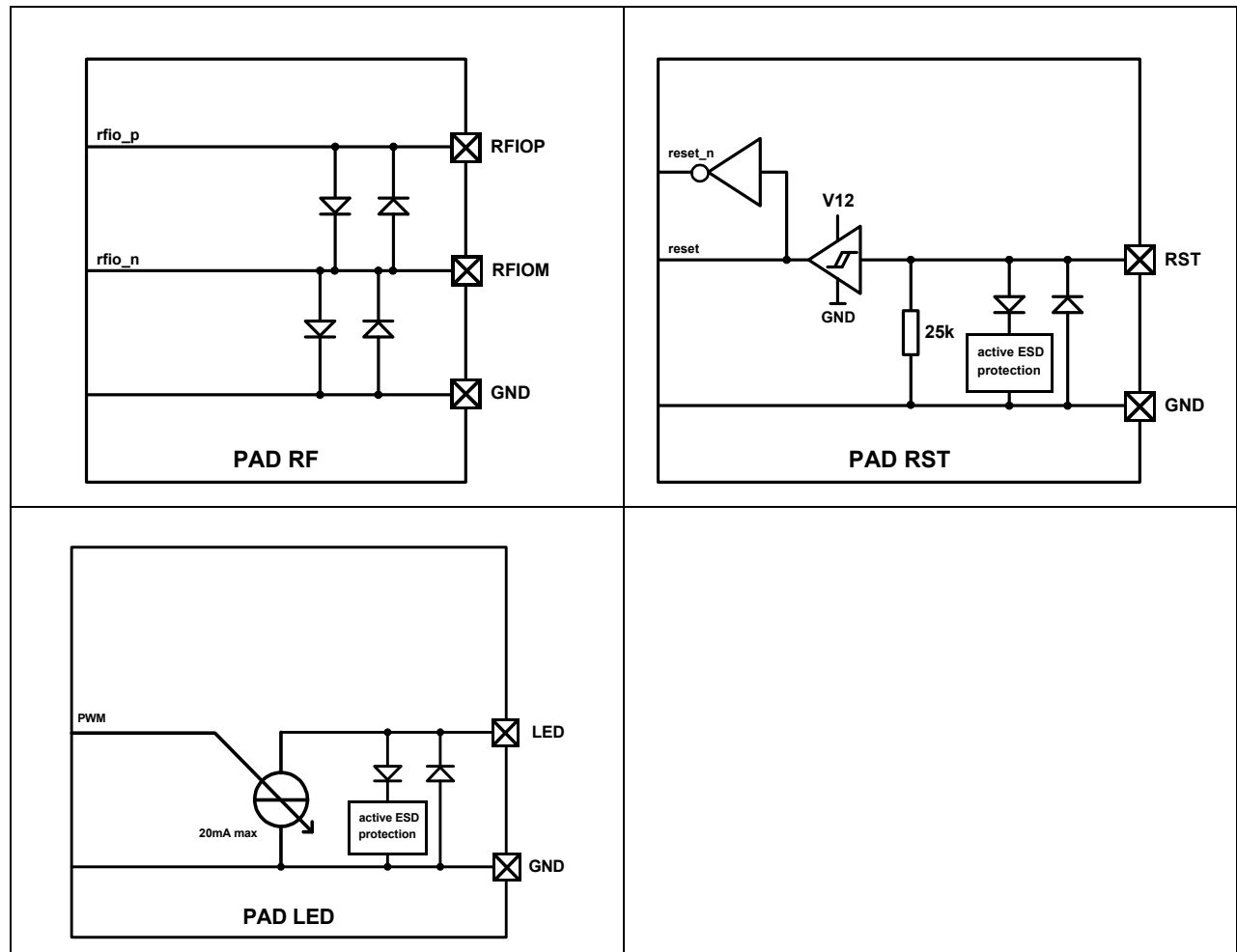

3 System overview

3.1 INTERNAL BLOCKS

The DA14681 contains the following blocks:

ARM Cortex™ M0 CPU with Wake-up Interrupt Controller (WIC). This processor provides 0.9 dMIPS/MHz and is used for implementing the higher layers of the Bluetooth Low Energy protocol. It is also used for the application requirements including controlling of the power scheme of the system, reaching up to 86 dMIPs if required. It is accompanied by a powerful cache controller with configurable associativity, cache line size and RAM size.

BLE 4.2 Core. This is the baseband hardware accelerator for the Bluetooth Low Energy protocol supporting all 4.2 features. such as data length extension, secure connections and enhanced privacy 1.2.

Co-existence The CoEx sub-block implements a coexistence interface with external collocated modules interfering with the 2.4GHz ISM band. A three wire interface is realized to sync with the external modules about the priority and the activity of the internal radio.

ROM. This is a 128 kB ROM containing the Bluetooth Low Energy protocol stack as well as the boot code sequence.

OTP. This is a 64 kB One Time Programmable memory array, used to store the application code as well as the Bluetooth Low Energy profiles. It also contains system's configuration and calibration values.

Data RAM. This is a 128 kB Data RAM (DataRAM) which can be used for mirroring the program code from the OTP when the system wakes/powers up or as a normal data RAM when the system executes code directly from OTP or external FLASH. It also serves as Data RAM for variables and various data that the protocol requires to be retained when system goes to sleep. It comprises 5 physical RAM cells, all with content retaining capability.

Cache/Tag RAM. This is a 16 kB data RAM used primarily by the cache controller (CacheRAM). It is accompanied by a Tag RAM. In mirrored mode the CacheRAM can be used as an extension of the DataRAM, increasing the available memory to 144 kB.

Cache controller. This is an instruction cache controller used for code execution directly from OTP or external QSPI FLASH, thus reducing accesses to these memories.

UART and UART2. Asynchronous serial interfaces. UART2 implements hardware flow control with a FIFO of 16 bytes depth.

SPI and SPI2. These are the serial peripheral interfaces with master/slave capability with a 16-bit wide FIFO of 16 places.

I2C and I2C2. These are Master/Slave I2C interfaces used for sensors and/or host MCU communication. Each controller includes a FIFO of 4, 9-bit locations.

QSPI Controller. Interface to an external Quad SPI FLASH device. It also supports single or dual SPI.

General purpose (GP) ADC. This is a 10-bit analog-to-digital converter with 8 external input channels and averaging capabilities, which increase the effective number of bits (ENOB) to 11.

Radio transceiver. This block implements the RF part of the Bluetooth Low Energy protocol at 2.4 GHz.

Clock generator. This block is responsible for the clocking of the system. It contains two crystal oscillators: one running at 16 MHz (XTAL16M), which is used for the active mode of the system, and one running at 32.768 kHz (XTAL32K), which is used for the sleep modes of the system.

There are also three RC oscillators available: a 16 MHz and a 32 kHz oscillator (RC16M and RC32K) with low precision (> 500 ppm) and a 10.5 kHz oscillator (RCX) with higher precision (< 500 ppm).

The RCX oscillator can be used as a sleep clock replacing the XTAL32K oscillator to reduce the bill of materials of the system. The RC16M oscillator is used to provide a clock for running SW already before the XTAL16M oscillator has settled after power/wake up.

Additionally, a low power, short lock time PLL can be activated to increase system's speed to 96 MHz.

Timers. This block contains a 16-bit general purpose timer (Timer0) with PWM capability, a 16-bit general purpose up/down timer (Timer1) with PWM capability, which can operate at any clock even when in sleep/deep sleep mode, and a 14-bit timer (Timer2), which controls three PWM signals with respect to frequency and duty cycle. The timer block also comprises a dedicated timer implementing an LED "breathing" function with 256 steps granularity.

Wake-up controller. This is a timer for capturing external events, that can be used as a wake-up trigger based on a programmable number of external events on any of the GPIO ports, or as a GPIO triggered interrupt generator when the system is awake.

Quadrature decoder. This block decodes the pulse trains from a rotary encoder to provide the step size and the direction of movement of an external device. Three axes (X, Y, Z) are supported.

Keyboard scanner. This circuit implements scanning and debouncing of a keyboard matrix and generates an interrupt when a report is ready on a key press/release.

Infrared (IR) generator. This controller implements a very flexible, low power, microcode based scheme for IR protocols primarily used for remote controls.

AHB/APB bus. Implements the AMBA Lite version of the AHB and APB specifications. Two different AHB busses are used, one for the CPU and one for the DMAs of the system. APB32 is implemented for the Audio peripherals while APB16 is used for the other peripheral blocks.

USB 1.1 FS Device. This is a 12 Mbit/s only USB device controller, which is mainly used for software upgrades. Its power source pin (VBUS) is used for recharging the system's battery.

Cryptography blocks. The cryptography blocks consist of a AES/HASH controller and an Elliptic Curve Controller (ECC), accelerating any application security requirements. A True Random Number Generator (TRNG) is also provided enabling secure key generation.

DMA Engine. This is a general purpose DMA engine with 8 channels that can be multiplexed to support data fetching between peripherals and DataRAM.

Audio blocks. This part enables audio streaming by means of a Pulse Density Modulation (PDM), a Sample Rate Converter (SRC) and a Pulse Code Modulation (PCM) interface. It can support 2 digital microphones or 2 digital loudspeakers using the PDM interface or connect an external CoDec at the PCM/I2S interface.

Power management. A sophisticated power management circuit with a Single Inductance Multiple Output (SIMO) Buck DC-DC converter and several LDOs that can be turned on/off via software. Extra pins are provided for supplying external devices, even when the DA14681 is in extended sleep mode. It also comprises a Constant Current/Constant Voltage (CCCV) charger for the battery charging and a state-of-charge fuel gauge circuit.

A more detailed description of each of the components of the DA14681 is presented in the following sections.

3.2 FUNCTIONAL MODES

The DA14681 is optimised for embedded applications such as health monitoring, sports measuring, human

interaction devices, etc. Customers are able to develop and test their own applications. Upon completion of the development, the application code can be programmed into the embedded OTP or external QSPI FLASH memory.

In principle, the system has two functional modes of operation:

A. Mirrored mode. Application, profiles etc. are all included in the OTP or external FLASH. They will be mirrored at boot or wake-up time into the unified RAM, which consists of both the CacheRAM and the DataRAM cells in a single, continuous memory space. Next, the CPU starts executing from the unified RAM, which is used for code as well as data.

During Mirrored mode the cache controller is totally bypassed while all of its RAM cells (except for the Tag RAM) are virtually moved into a continuous memory space.

B. Cached mode. This mode uses the memory resources of the system as described in the block diagram. The cached area can be OTP and/or the external FLASH memory space. Code is executed directly from the OTP/FLASH through the cache controller, while DataRAM is used for intermediate variables, stacks, heaps and application data.

Mirrored mode or Cached mode should be configured during initialisation of the system and not dynamically.

There are several different ways of executing code and mapping the data segment of the system. The following table provides an overview of the different possibilities for BLE product use cases.

Table 4: Memory configurations

Use case	BLE stack code	Application and profile code	BLE Exchange RAM and data	Functional mode
BLE_01	ROM	OTP	DataRAM	Mirrored
BLE_02	ROM	FLASH	DataRAM	Mirrored
BLE_03	ROM	OTP	DataRAM	Cached
BLE_04	ROM	FLASH	DataRAM	Cached
BLE_05	FLASH	FLASH	DataRAM	Cached

In addition, it is also possible to use parts of the DataRAM as code segments. In that case, parts of the code can be placed in the DataRAM (a non-cacheable area), while the system is operating in cached mode.

3.3 SYSTEM CONFIGURATION

The DA14681 contains a 64 kB One Time Programmable (OTP) memory, which is used for storing the code (as explained in Table 4) and for retaining the system's configuration data in a special OTP space called the "OTP header".

The OTP header occupies the last 712 words (64 bits

wide) in the OTP memory space. It is partitioned into four sections that contain vital information for the system, as illustrated in the following table.

Table 5: OTP header details

Address	Size (B)	Field name	Description
0x7F8E9C0	184	Chip Configuration Section (CCS)	
0x7F8E9C0	8	Mirrored/Cached At startup	0: Mirrored 1: Cached
0x7F8E9C8	8	Non-Volatile Memory	0: FLASH Anything else: OTP
0x7F8E9D0	8	Product Ready	0x00: OTP or FLASH not programmed 0xAA: OTP or FLASH programmed
0x7F8E9D8	8	Redundancy	0: Used 1: Not used
0x7F8E9E0	8	Reserved	
0x7F8E9E8	8	Shuffle RAMs	Define the sequence of the RAM cells in a continuous memory space 0x0: DataRAM1, DataRAM2, DataRAM3 0x1: DataRAM2, DataRAM1, DataRAM3 0x2: DataRAM3, DataRAM1, DataRAM2 0x3: DataRAM3, DataRAM1, DataRAM1 DataRAM1=8KB, DataRAM2=24KB, DataRAM3=32KB
0x7F8E9F0	8	JTAG	0x0: Enabled 0x1: Disabled
0x7F8E9F8	8	Sleep Clock	0x0: XTAL32 0x1: RCX
0x7F8EA00	8	Position/Package	B7-B4: Reserved. Keep these values to 0 B3: 0x00 – WLCSP 0x55 – aQFN60(DA14681/DA15101) 0x99 – KGD B2: Wafer number B1: Y coord, B0: X coord.
0x7F8EA08	8	Tester/Timestamp	B7: Reserved B6: Tester ID (MSByte) B5: Tester ID (LSByte) B4: Tester Site B3: TimeStamp Byte 3 B2: TimeStamp Byte 2 B1: TimeStamp Byte 1 B0: TimeStamp Byte 0
0x7F8EA10	8	Mirror Image Length	Contains the size of the image to be mirrored (unit: 32-bit words)
0x7F8EA18	8	Reserved	
0x7F8EA20	8	Chip Unique ID	ASCII code for “14681AE “

Table 5: OTP header details

Address	Size (B)	Field name	Description
0x7F8EA28	8	Cache architecture	Defines the Cache architecture to be programmed at SW reset: Bits[3:0] Cache Line Size 0x0: 8 bytes 0x1: 16 bytes 0x2: 32 bytes 0x3 - 0x7: RESERVED Bits[7:4] Associativity 0x0: Direct Mapped 0x1: 2-way set 0x2: 4-way set 0x3 - 0x7: RESERVED Bits[11:8] Cache Size 0x0: RESERVED 0x1: 8 KBytes 0x2: 16 KBytes 0x3-0x7: RESERVED Bits[15:12] RESERVED
0x7F8EA30	8	Serial Configuration Mapping	B0[7:4]: Serial signal 1, port number B0[3:0]: Serial signal 1, bit number B1[7:4]: Serial signal 2, port number B1[3:0]: Serial signal 2, bit number B2[7:4]: Serial signal 3, port number B2[3:0]: Serial signal 3, bit number B3[7:4]: Serial signal 4, port number B3[3:0]: Serial signal 4, bit number B4: Booting Method 0xAA: booting from a specific serial port (B5) and at a specific location (B0 to B3) 0x00: normal booting sequence B5: Serial Interface: 0x0: None 0x1: UART 0x2: UART2 0x3: SPI 0x4: SPI2 0x5: I2C 0x6: I2C2 B6: if UART/UART2 is selected: 0x0: 115 kBaud, 0x1: 57.6 kBaud, 0x2: 38.4 kBaud, 0x3: 19.2 kBaud, 0x4: 9.6 kBaud SPI is not applicable since it is a slave interface if I2C/I2C2: 0x0: Standard Mode (100 kbps) 0x1: Fast Mode (400 kbps) B7: RESERVED
0x7F8EA38	8	Image CRC	CRC16 checksum for the programmed image
0x7F8EA40	8	Reserved	Reserved

Table 5: OTP header details

Address	Size (B)	Field name	Description
0x7F8EA48	8	QSPI Functions	Bit0 0: Reset Function of QSPI FLASH is in BootROM 1: Reset Function of QSPI FLASH is in OTP Bit1 0: Find "qQ" Function of QSPI FLASH is in BootROM 1: Find "qQ" Function of QSPI FLASH is in OTP Bit2 0: QSPI loader of QSPI FLASH is in BootROM 1: QSPI loader of QSPI FLASH is in OTP
0x7F8EA50	8	UART STX timing	Defines the delay for booting from UART in units of 10 ms each.
0x7F8EA58	32	BDADDR	Bluetooth Address
0x7F8EA78	384	Trim and Calibration Section (TCS)	
0x7F8EA78	8	Trim and Calibration Register Address	B7 to B5: Inverted address B3 to B0: Address
0x7F8EA80	8	Trim and Calibration Register Value	B7 to B5: Inverted data value B3 to B0: Data value
0x7F8EA88	368	Trim values	Contains all trim values and calibration values in word pairs (Address, Value)
0x7F8EBF8	3072	Elliptic Curve Contents Section (ECS)	
0x7F8EBF8	8	ECC image length and CRC	B7 to B5: Inverted value of B3-B0 B3 to B2: Image CRC B1 to B0: Image length in 32-bit words
0x7F8EC00	3064	ECC microcode	Contains all ECC microcode for the Curves implementation
0x7F8F7F8	2048	QSPI FLASH Initialization Section (QFIS)	
0x7F8F7F8	8	Address for the QSPI Reset code	B7-B5: Section length (Bytes) B3-B0: Address
0x7F8F800	8	Address for the QSPI "pP" identification code	B7-B5: Section length (Bytes) B3-B0: Address
0x7F8F808	8	Address for the QSPI Loader code	B7-B5: Section length (Bytes) B3-B0: Address
0x7F8F810	8	Address for the QSPI wake up uCode	B7-B5: Section length (Bytes) B3-B0: Address
0x7F8F818	2016	Contains all QSPI related code segments	

Integrity of the data in the OTP header is guaranteed in various ways. The OTP controller has an embedded Error Correction Code hardware block, which can correct 1 bit error and detect 2 bit errors.

Furthermore, the *Chip Configuration Section* contains mostly flags with redundancy over the whole 64-bit word to ensure no mistaken value will be read. The flag value is repeated over all bytes of the word.

The *Trim and Calibration Settings Section* comprises the addresses and data values of the registers to be configured after power/wake up. The OTP contains the inverted values of both the address and the data values in the most significant 32-bit word. Reading from

OTP, checking and then storing the value into the respective register is considered to be a fast and easy task for software.

The *Elliptic Curve Contents Section* contains its own CRC-16 checksum, while the actual OTP image (not present in the header) is also optionally protected by a CRC-16 checksum (Image CRC).

The *QSPI FLASH Initialisation Section* relies on the OTP controller reports for integrity.

3.4 SYSTEM STARTUP PROCEDURE

After power-on or wake-up, a hardware state machine is started, which resides in the Power Management

Unit. Following this, the CPU will start executing code from address 0x0. If the system is just powered-up, then ROM resides at 0x0 hence the bootROM sequence will be triggered. If the system was just waken-up, then address 0x0 is remapped to either the Data-RAM or one of the Non-Volatile resources of the chip hence code is directly executed from there.

3.4.1 Power/Wakeup FSM

The hardware FSM is responsible for starting the main LDOs of the system and power the main rails used for supplying the digital and analog resources of the chip. The flow chart of this state machine is presented in [Figure 4](#). System clock after Power On Reset is released, is the 32 kHz coming from an on-chip RC oscillator (RC32K). The FSM will initially compare the voltages between pins VBUS and VBAT. This embedded PMU feature provides a digital signal for deciding which LDO to start so that Vsys is powered up. Please refer to [Figure 7](#) for an overview of the LDOs.

When VBUS is present (the system is connected to the USB for recharging or software upgrading), the PMU powers the whole system from VBUS instead of VBAT. Therefore a dedicated LDO_USB will be started. The LDO_USB has its own reference and will switch to the Bandgap reference voltage as soon as this has settled.

When no VBUS is detected (no USB connection), the LDO_VBAT will be turned on, followed by the Bandgap. The LDO_VBAT also has its own reference for starting up and will automatically switch to the Bandgap reference.

The next step is to start the LDO_IO2 and LDO_IO, which provides power to the external rails, mostly targeting external QSPI FLASH if available. Then the LDO_CORE is enabled to supply the VDD voltage (1.2 V) for the digital core to start operating. From that point onwards and provided that the LDOs are settled, the digital system is up and running.

Next, both 16 MHz oscillators are started. The system clock switches to the 16 MHz RC clock to start OTP mirroring or any other initialisation procedure that has to do with an external FLASH.

Then the CPU can take over and either start executing code from RAM (in the case of wake up) or ROM (in the case of power up). If executing code from RAM, it should switch on the SIMO DC-DC converter, disable the LDOs to lower the power consumption of the digital part and operate the radio. For a detailed overview of the PMU, please refer to [Figure 9](#) and for a representation of the timing of the power up/ wake up process refer to [Figure 17](#).

The latency of the hardware FSM is not always the same. It is depending on power up or wake up and more specific, in the case of wake up, it depends on the time the system has been sleeping before.

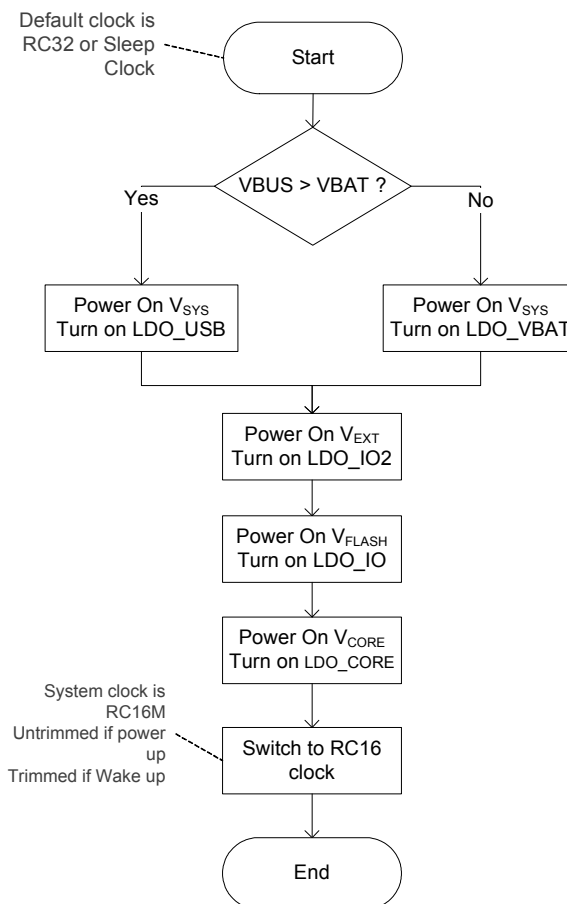

Figure 4: Power/Wakeup FSM flow diagram

When powered up the default clock is the RC32 which is close to 32 kHz. The time required for the completion of the HW FSM is 16 clock cycles i.e. 0.5 ms. If the system wakes up, then the sleep clock is used: either the XTAL32K (32 kHz) or the RCX (10.5 kHz). Depending on the amount of time slept, there might be some energy in the LDOs left or not, hence the settling time might be less than expected. This process might take 11 to 16 clock cycles i.e. minimum 0.35 ms, maximum 1.6 ms.

3.4.2 Goto Sleep FSM

After the sleep command has been issued (WFI), the system will switch to operating on RC16M and the HW FSM described in the flow chart of will take over:

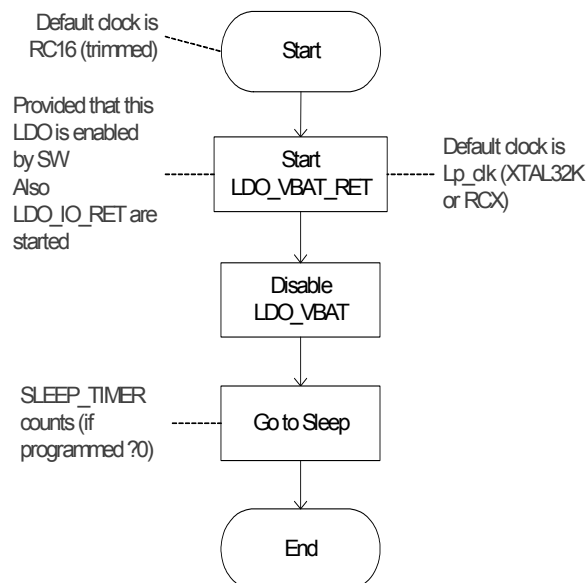

Figure 5: Go to Sleep FSM flow diagram

Depending on the programming of the respective control registers the FSM will switch to the `lp_clk` and then start (or not) the `LDO_VBAT_RET` to provide power at the `Vsys` rail. `LDO_IO_RET` and `LDO_IO_RET2` will also be enabled (or not, depending on SW programming) during this state. Additionally, the `LDO_CORE` is disabled letting the `LDO_SLEEP` take over the supply of the always on logic.

Following that, the FSM will disable the `LDO_VBAT` and the `LDO_IO/LDO_IO2`.

Finally during the `Go to Sleep` state, the `SLEEP_TIMER` starts counting if there has been a value programmed in the `SLEEP_TIMER_REG` and the system goes into sleep.

A detailed timing diagram of the go to sleep procedure is illustrated at [Figure 18](#).

3.4.3 BootROM sequence

The BootROM sequence will be triggered right after a power-up or when the latest remapping of address 0 is pointing to the ROM.

The booting process of the DA14681 is presented in [Figure 6](#).

The BootROM code starts with the RC16 oscillator active but untrimmed, which provides an average frequency of 10 MHz in typical conditions. The BootROM code starts the watchdog timer, which will fire only after 2 seconds if not re-initialised.

Next, the OTP controller is initialised and two important configuration flags are read and evaluated: the sequence of the RAM cells and whether JTAG should be enabled or not. Especially for the latter, if it is disa-

bled, there is no way of enabling it again even by the application.

Following that, trim and calibration values are read from the OTP and stored into the respective retention registers. Note that the *TCS Section* of the OTP header (see [Table 5](#)) contains all register addresses and values that are being measured during production testing or any other values that are required to be retained. These values are all stored into their respective registers using a 'while' loop, which reads and evaluates all TCS slots.

From that point onwards, the trimmed RC16 oscillator provides a clock frequency very close to 16 MHz.

The TCS values are protected using inverted redundancy. When a voltage dropout occurs while reading or writing the value, an incorrect redundancy check will re-initiate the copy action. When copying is still unsuccessful after 5 attempts, a hardware reset will be triggered.

After a very short delay of approximately 200 us, the XTAL16M oscillator is enabled.

The "Product Ready" flag defines whether the system should follow the 'NVM' or the 'SERIAL' booting paths of the flow chart. In the NVM case, the system is supposed to start executing code from a Non-Volatile memory (NVM), which can either be the OTP or the QSPI FLASH in any of the functional modes.

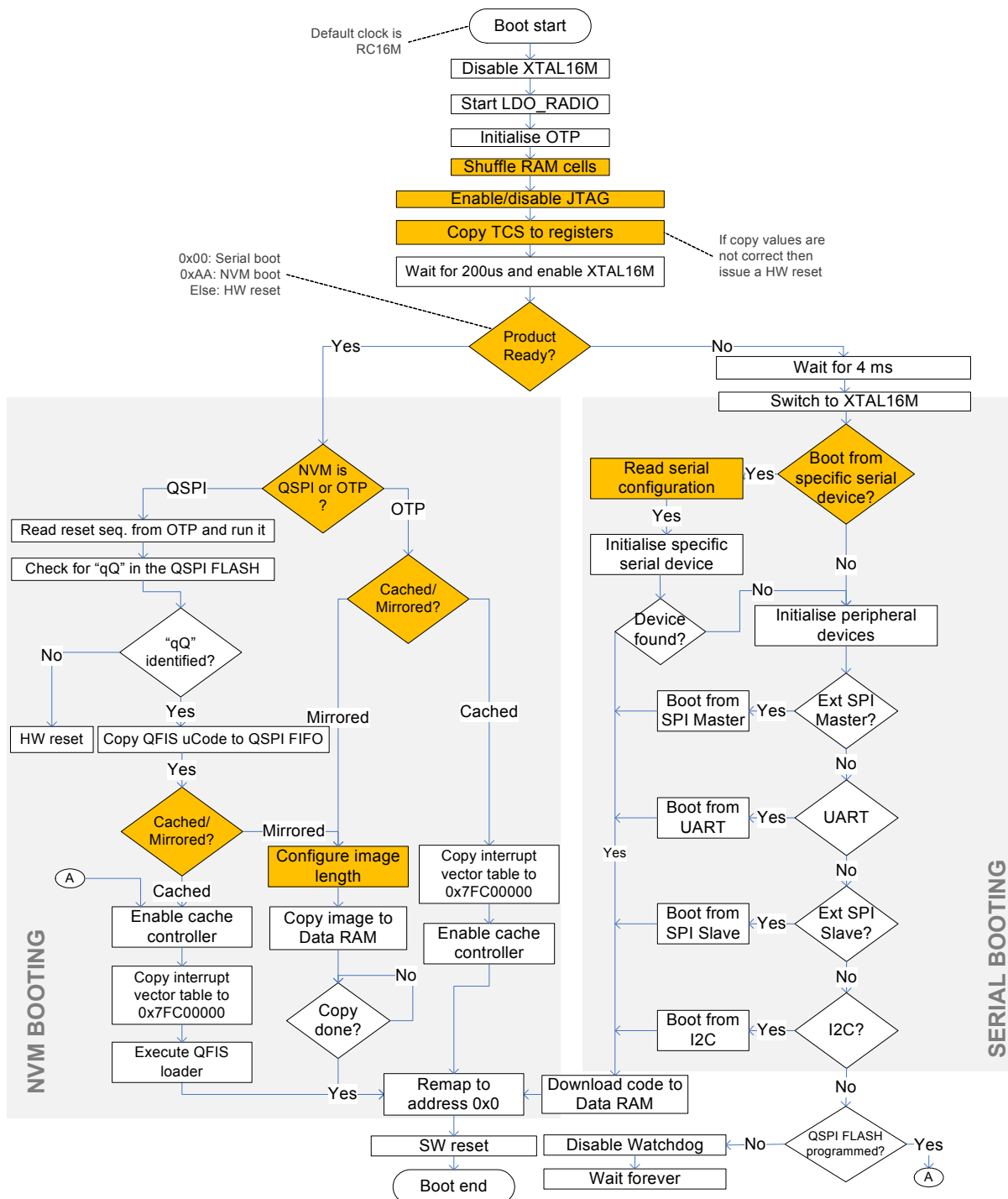

Figure 6: BootROM sequence

Colored boxes indicate OTP header access.

The NVM booting sequence is as follows:

1. If the NVM is the QSPI FLASH:
 - Read the reset sequence from the OTP and

apply it to the QSPI FLASH.

- Initialise the FLASH.
- Check whether there is a magic word written in the FLASH (ASCII for "qQ").

- Download uCode for FLASH into the controller from the QFIS segment of the OTP header.
 - Identify in which memory mode the system is operating (Cached or Mirrored):
 - *Mirrored mode*: the Application code is copied into the DataRAM and the cache controller is bypassed, attaching the cache RAM to the DataRAM memory space.
 - *Cached mode*: the cache controller is initialised as specified by the architectural parameters and the interrupt vectors are copied at the beginning of the DataRAM.
2. If the NVM is the OTP, then the same happens in Mirrored mode, while the Cached mode only requires the interrupt vector copy.
 3. Remap address 0 to QSPI or OTP.
 4. End the booting sequence with a software reset.
- In the case of a non-'Product Ready' device, the system clock is switched to the XTAL16M after a delay of 4 ms. This is required for making sure the oscillator is settled. From this point there are two options in the BootROM code:
1. **Booting from a specific serial interface.** This provides the ability to directly download code from a specific serial interface without scanning for a connected device first. This is to be used in cases where an external MCU will boot the DA14681. The configuration of the serial interface in terms of pin location, controller and speed is to be found in the OTP header as explained in [Table 5](#).
 2. **Booting from any connected device** by scanning a predefined number of GPIOs and interfaces. When the respective flag is not set in the OTP header, booting from any serial interface will occur. This provides the flexibility to initially boot from a UART or an SPI at a totally blank device to start development of applications. All serial interfaces will be exercised once using the protocols described in *AN-B-046*. When no connection has been established, then a final attempt is performed for identifying a valid QSPI FLASH and if that is also unsuccessful, the system gets into a while forever loop.

The sequence of the steps that the booter takes while scanning for an external device is presented in the following table:

Table 6: Scanning steps for booting from serial

Step	Boot from	Speed
0	SPI Master MISO => P0_1 MOSI => P0_2 SPI_CLK => P0_3 SPIC_S => P0_4	Defined by Master

Table 6: Scanning steps for booting from serial

Step	Boot from	Speed
1	UART UTX => P0_1 URX => P0_2	115.2 kbps
2	UART UTX => P0_5 URX => P0_3	57.6 kbps
3	UART UTX => P1_0 URX => P1_5	57.6 kbps
4	UART UTX => P1_2 URX => P1_4	57.6 kbps
5	UART UTX => P1_3 URX => P2_3	57.6 kbps
6	SPI Slave MISO => P0_2 MOSI => P0_1 SPI_CLK => P0_0 SPIC_S => P0_5	2 MHz
7	I2C SCL => P0_1 SDA => P0_2	400 kbps
8	I2C SCL => P0_5 SDA => P0_3	400 kbps
9	I2C SCL => P1_0 SDA => P1_5	100 kbps
10	I2C SCL => P1_3 SDA => P2_3	100 kbps

3.5 POWER CONTROL AND MODES

3.5.1 System Power Control

The PMU supports operation from coin-cell, 2x AAA and rechargeable Lithium-Ion batteries. An overview diagram is shown in [Figure 7](#).

There are three main supply (input) pins: VBUS, VBAT1 and VBAT2. VBUS is only used in case a USB supply is connected to the device. In all other cases, VBAT1 and VBAT2 are used, the first being the supply of the LDOs and the second the DC-DC converter supply. VBAT1 and VBAT2 should be shorted together.

From VBAT1 or VBUS, the system supply (Vsys) is generated by either LDO_USB or LDO_VBAT. Vsys is used to power an accurate bandgap reference, the internal sleep oscillator (RCX) and the I/O pins. In case the DC-DC converter is not activated, Vsys is also used to generate the Vcore for the digital domain and the I/O supply.

The Radio, ADC, PLL and the Xtal16M oscillator can be supplied by either the 1.4 V DC-DC converter output or by the LDO_Radio.

The Single Inductor Multiple Outputs (SIMO) DC-DC converter has four dedicated outputs and has an average efficiency of 82% when activated. Two of its outputs (VDD1V8 and VDD1V8P) deliver power to external devices, even when the system is in sleep mode, by using the LDO_RET_IOx. When the VBAT1 voltage is too low to achieve a correct conversion, the LDO_IOx will still keep the outputs powered.

In addition to the main supplies described above, the PMU has several features to support ultra low power sleep modes, where large parts of the system are turned off. There is a dedicated supply domain that is

always active and is generated either from VBUS or VBAT. This power domain is only used for the retention circuits. The LDO_SLEEP supplies Vcore when all other power supplies are off. This supply is used for the digital wake-up state machine and retention during sleep modes. A low power 32 kHz oscillator (RC32) is used as a clock for the digital state machine.

External devices might be powered by the VDD1V8, VDD1V8P or even V33 pins, exploiting the DC-DC converter efficiency and further optimising the system's power dissipation. External QuadSPI FLASH devices and other components such as sensors can be powered by the VDD1V8 or VDD1V8P or even V33 pins.

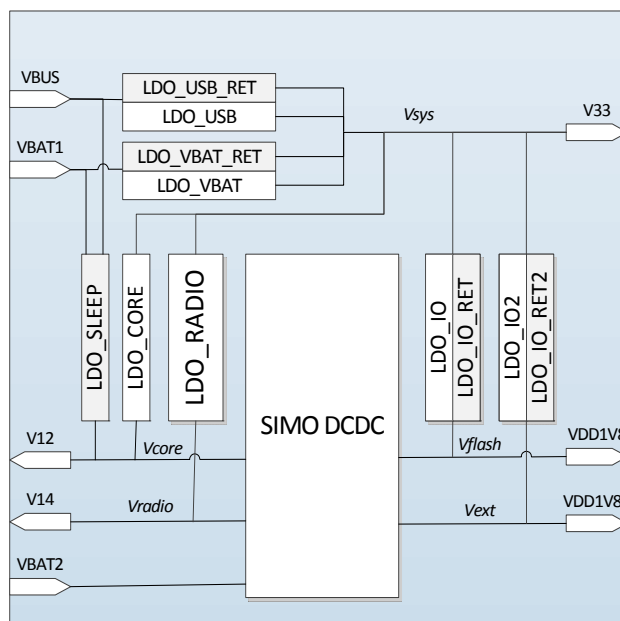

Figure 7: Power Management Unit overview

3.5.2 Power domains

The DA14681 comprises several different power domains, that are controlled by power switching elements, thus eliminating leakage currents by totally powering them down.

The partitioning of the DA14681's resources with respect to the various power domains is presented in the following table.

Table 7: Power domains

Power domain	Description
PD_AON	Always On. This power line connects to all resources that must be powered constantly: the ARM/WIC, the BLE Timer, Timer1, the Retention SRAM, the PMU/CRG, the Wake-up controller, the pad ring and various registers required for the Wake-Up sequence.
PD_SYS	System. This power line connects to all resources that should be powered only when the ARM Cortex M0 is running: the AMBA bus, the OTP cell and controller, the QSPI controller, the ROM, the DataRAM the Watchdog timer, the SW timers, the crypto controllers, the USB and the GPIO port multiplexing.

Table 7: Power domains

Power domain	Description
PD_PER	Peripherals. This power line connects to the peripherals that can be switched off after completing their operation: the UARTs, the SPI, the I2C the Keyboard scanner, the ADC etc.
PD_RAD	Radio. This is the power island that contains the digital part of the Radio: the Modulator/Demodulator, the RF control unit and register file. The power management of the analog Radio subsystems is done within the Radio itself, since it contains several LDOs.
PD_BLE	BLE. This is a separate power island that only contains the Bluetooth Low Energy Lower Mac hardware block.

An illustration of the power domains on the chip block diagram is presented in the following figure.

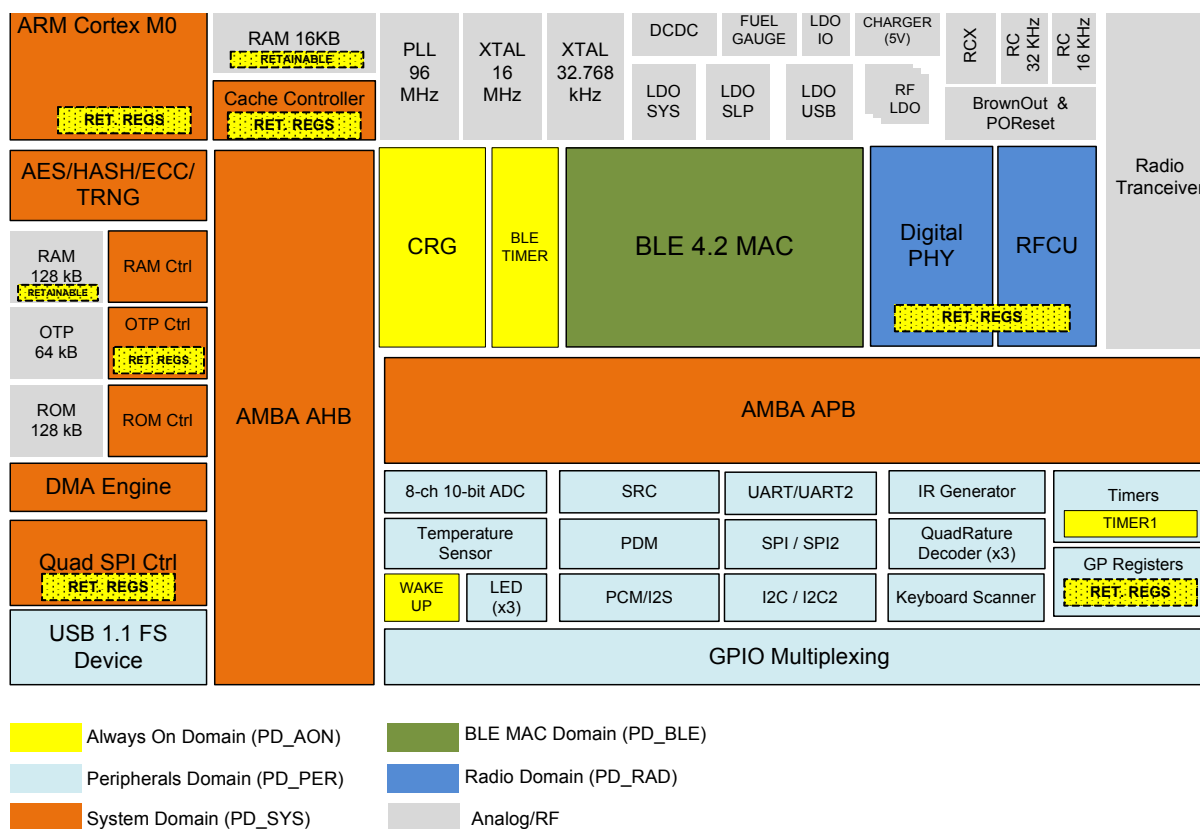

Figure 8: DA14680 digital power domains

There are specific blocks containing retention registers. These are register that keep their contents even when their power domain has been switched off.

Moreover, all DataRAM and CacheRAM blocks have their own retaining mechanism, i.e. they can be programmed to retain their content independently of the status of the power domains.

3.5.3 Power modes

The DA14681 has four main power modes, which are distinguished by the power domains and clocks that are active:

1. Active mode
2. Extended Sleep mode
3. Deep Sleep mode
4. Hibernation mode

However, there are several different configurations for each power mode, depending on the amount of RAM being retained and whether the DC-DC converter is kept powered on or not.

The different configurations are presented in Table 8.

Table 8: Power modes and configurations

Power mode	Power domains	Analog blocks	Clocks available	Retained memory	Wake-up mechanism	Description
Active	AON_PD=ON SYS_PD=ON BLE_PD=OPT ¹ RAD_PD=OPT PER_PD=OPT	LDO_USB = OFF LDO_RET=OFF LDO_VBAT=ON LDO_IO=OPT BandGap=ON LDO_CORE= OPT SIMO= OPT LDO_RAD=OPT LDO_VBAT_RET=OPT LDO_VBUS_RET=OFF LDO_IO_RETx=OPT LDO_SLEEP=OFF	XTAL16M RC16 XTAL32K (optional) RCX RC32 Radio activity requires XTAL16M clock	All memories are powered up and accessible	No wake up required. System is up and running	During this mode the RAM (mirrored mode) (cached mode). The Radio, the BLE domains can optionally according to the application is in control of these. If the system is idle, turned off except AC clock to lowest value. WFI command.
Extended Sleep	AON_PD=ON SYS_PD=OFF BLE_PD=OPT RAD_PD=OPT PER_PD=OPT	LDO_USB=OFF LDO_RET= ON LDO_VBAT=OFF LDO_IO=OPT BandGap=OFF LDO_CORE=OFF SIMO=OFF LDO_RAD= OPT LDO_VBAT_RET=ON LDO_VBUS_RET=OFF LDO_IO_RETx=OPT LDO_SLEEP=ON	Low power clock: XTAL32K (optional) RCX Either of the above	8KB to 128KB Granularity is: 8KB 24KB 32KB 16KB Cache will be automatically retained if in cached mode	Synchronously to the BLE anchor points using the Low power clock (XTAL or RCX) BLE timer Asynchronously to the BLE anchor points from an external device powered from battery via any GPIO Asynchronously to the BLE anchor points from Timer1 interrupt.	The Extended Sleep mode is a variation to the protocol. In case of Mirrored mode code then OTP or F code is required, on wake-up. In case of code is required, on. In case of external clock system, there are two externally or from the
Deep Sleep	AON_PD=ON SYS_PD=OFF BLE_PD=OPT RAD_PD=OPT PER_PD=OPT	As above	RC32. Before switching into Deep Sleep mode, RC32 has to be active.	As above	Asynchronously to the BLE using any GPIO. The toggling activity on any of the selected pins enables RC32. ²	The Deep Sleep mode is inactivity for the system. The RAM can still be accessed. happen from an external
Hibernation	AON_PD=ON SYS_PD=OFF BLE_PD=OPT RAD_PD=OPT PER_PD=OPT	As above	RC32. Before switching into Deep Sleep mode, RC32 has to be active.	None	Asynchronously to the BLE using any GPIO. The toggling activity on any of the selected pins enables RC32.	The Hibernation mode is inactivity for the system. product shipping mode. There is no RAM retained.

1 : OPT means optionally on or off, configured by software

2 : The wake up GPIO must be configured at WKUP_SELECT_Px_REG before going to sleep

4 Power management

The DA14681 has a complete integrated power management unit (PMU) which comprises a Single Inductance Multiple Output (SIMO) DC-DC converter with 4 outputs, various LDOs for the different power domains of the system, a Constant Current Constant Voltage (CCCV) charger for battery recharging, a charge detection circuit and a fuel gauge revealing the remaining battery charge. The PMU is capable of supplying external devices even when the DA14681 is in sleep mode.

The system diagram of the analog Power Management Unit (PMU) is presented in Figure 9.

Features

- Synchronous Single Inductance Multiple Output Buck DC-DC converter with 4 output power rails
- Programmable DC-DC converter output charging sequence

- Two DC-DC converter outputs at 1.8 V with 75 mA load capability for powering external devices
- One LDO output up to 3.6 V with up to 110 mA load capability
- DC-DC converter on/off control per output
- Active and Sleep mode current limited LDOs
- Use of small external components
- Supply of external rails (V33, VDD1V8, VDD1V8P) while DA14681 is in Sleep mode
- Fuel gauge to indicate state-of-charge
- CCCV charger with battery/die-temperature protection
- Interrupt line for the DCDC converter

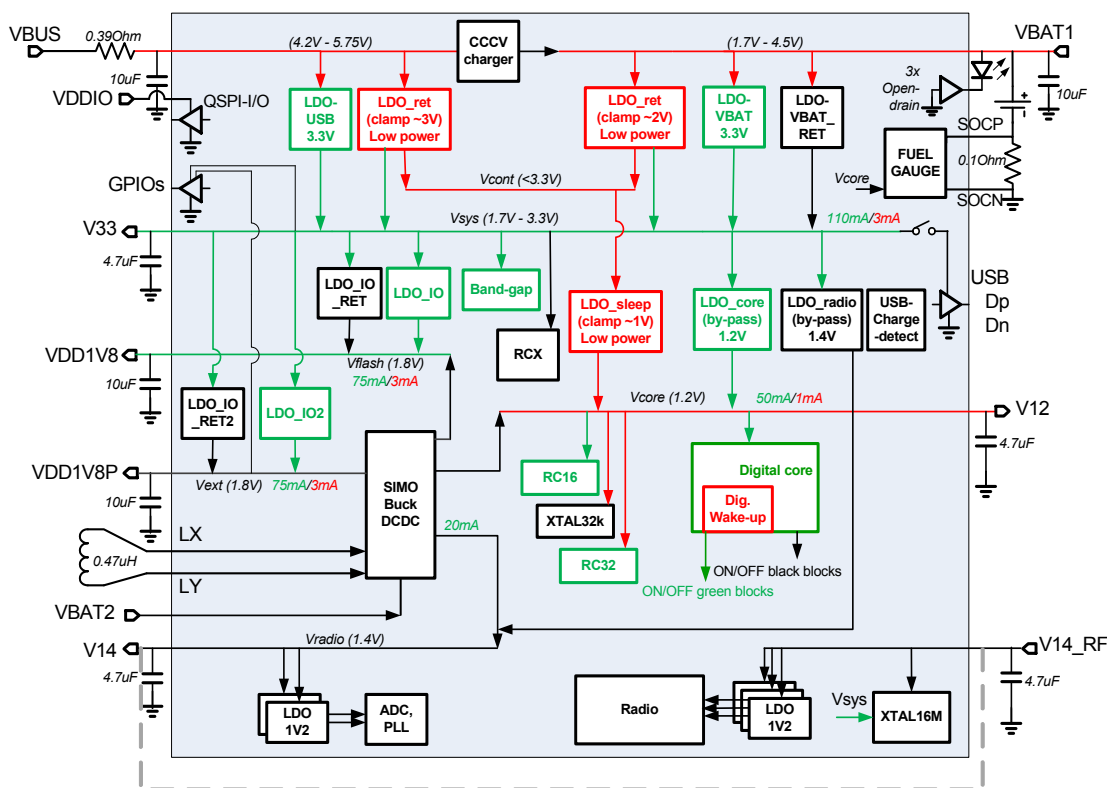

Figure 9: Power management unit block diagram

Note 1: Quality of the V14_RF de-coupling capacitor is affecting the radio performance

Note 2: Proposed de-coupling capacitor values provide best system performance

Note 3: All de-coupling capacitors should be placed as close to the respective pin as possible

4.1 ARCHITECTURE

There are 3 main power inputs, namely VBUS, VBAT1

and VBAT2. The VBUS is connected when charging the battery through the USB connector. VBAT1 should be shorted with VBAT2 externally and supplies the LDOs, while VBAT2 supplies the SIMO DCDC converter. There are certain parts of the PMU which are always powered. They are designated in red in Figure 9. The always on power circuitry consists of 2 clamps and LDO_SLEEP which provides the necessary voltage when the system is in extended sleep, deep sleep or hibernation mode. When the system wakes up, then

many of the blocks of the PMU are activated automatically (in green) as explained in the power/wake up sequence flow charts. Finally, SW is responsible for activating the SIMO DCDC and any other block which is in black in [Figure 9](#).

The current that the PMU can deliver on each rail in Active/Sleep mode is presented in the following table. Note that V14 and V12 are used for the radio and the core respectively. Therefore it is recommended that

they are not used to supply any external devices. Especially V14 should be connected via the PCB to the V14_RF as displayed in [Figure 9](#).

I_{DIG} and I_{RAD} define the currents dissipated by the digital core and the radio, respectively, while I_{V18_ACT} represents the current load on both 1.8 V power rails.

Table 9: PMU current supply capabilities

Parameter	Description	Conditions	Maximum value	Unit
$I_{V33_ACT_LDO}$	Current drawn from pin by external devices when in Active mode	Power from LDO_VBAT	$100 - I_{V18_ACT} - I_{DIG} - I_{RAD}$ $I_{V18_ACT} = I_{LDO_IO} + I_{LDO_IO2}$	mA
I_{V33_SLEEP}	Current drawn from pin by external devices when in Sleep mode	Power from LDO_VBAT_RET	$2 - I_{V33}$	mA
$I_{V18_ACT_LDO}$	Current drawn from pin by external devices when in Active mode	Power from LDO_IO/LDO_IO2	$100 - I_{V33_ACT} - I_{DIG} - I_{RAD} - I_{V18_ACT}$. Max 75 mA	mA
$I_{V18_ACT_SIMO}$	Current drawn from pin by external devices when in Active mode	Power from DCDC	75	mA
I_{V18_SLEEP}	Current drawn from pin by external devices when in Sleep mode	Power from LDO_IO_RET/ LDO_IO_RET2	For each LDO: $2 - I_{V33_SLP}$	mA

4.1.1 SIMO DC-DC converter

The heart of the PMU is the SIMO Buck DC-DC converter. The block diagram is displayed in the following figure:

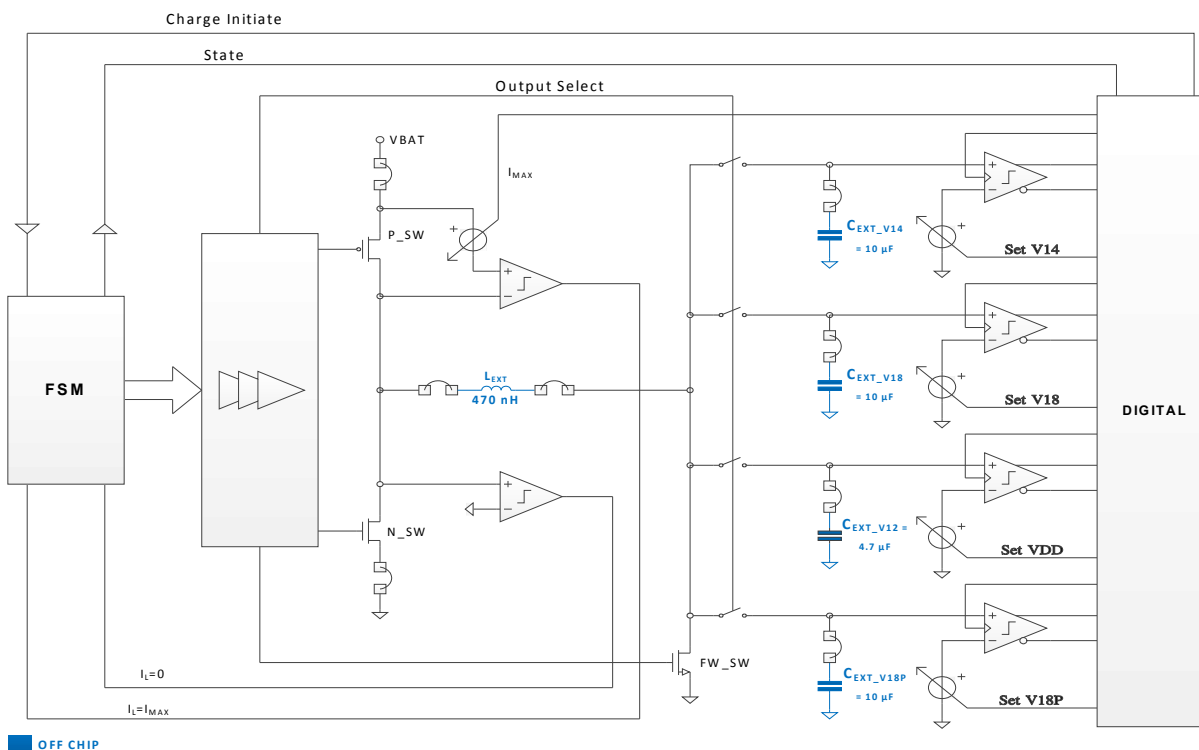

Figure 10: SIMO DCDC Converter block diagram

the DCDC converter comprises 4 outputs:

- **Vext** which connects to the VDD1V8P pin and delivers 75 mA when DA14681 is in active. The voltage range of this power rail is 1.8 V +/- 5%. External devices, such as Power Amplifiers (PA), Front End Modules (FEMs) or sensors can be powered by this rail.
- **Vflash** which is used for supplying external devices, such as QSPI FLASH or sensors. This rail's characteristics are identical to the Vext one.
- **Vradio** which powers the RF circuits via a number of dedicated LDOs. This rail delivers up to 20 mA at 1.4 V and should not be used for supplying external devices.
- **Vcore** which supplies the digital core of the DA14681 and delivers up to 50 mA at 1.2 V when in Active mode. This rail should not be used for supplying external devices.

The converter has an asynchronous architecture, i.e. the on-time of the switches is not determined by an external clock. Instead, the on-time is determined by a (dynamically varying) current limit in the external inductor. If one of the output voltages is too low (determined using clocked comparators) a charge cycle is triggered.

However, it is possible for more than one outputs to be below minimum at the same time, in which case the system has to decide which output to charge first. This

is done using a priority select register, which holds the sequence in which the outputs will be charged. Each time one or more outputs require a charge cycle, the system sorts the outputs based on this priority register and loads this sequence in a four tab shift register.

In order to minimize the ripple voltage on the outputs, the current limit is dynamically set during operation in Active mode. This is done by measuring how long each output is above its minimum value after a charge cycle. When this time is very long, more charge than required (given the load current) was stored on the output capacitor, so the current limit is reduced by one bit (LSB). However, when the output voltage drops too quickly, not enough charge was delivered to the output capacitor, so the current limit is increased by one bit (LSB).

The efficiency of the DCDC converter on the VDD1V8 or VDD1V8P is illustrated in the following figure. It is measured at three battery voltages (VBAT). The load on V14 and V12 is kept constant at 2mA and 5mA respectively.

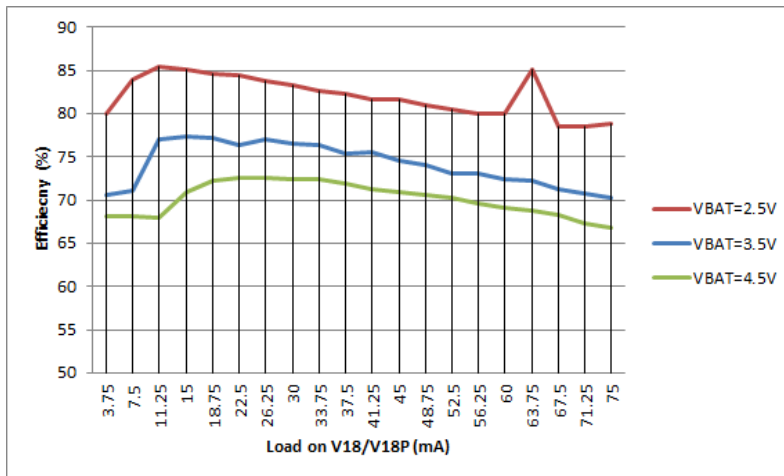

Figure 11: 1.8V rails DCDC efficiency vs load

Efficiency for sub-mA loads, i.e. between 100 uA and 1 mA is over 70% for VBAT > 3.5 V and over 80% for VBAT < 3.5 V.

the load as well as different VBAT voltages, is presented in the following figures:

The efficiency of the V12 and V14 rails with respect to

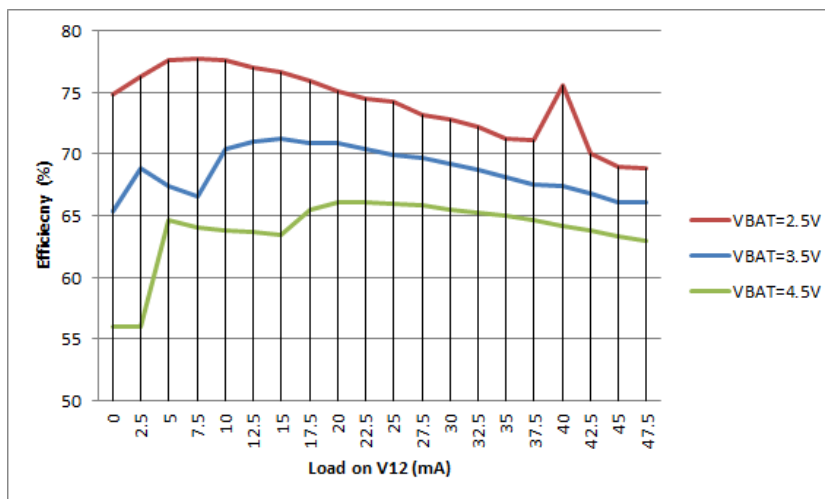

Figure 12: 1.2V rail DCDC efficiency vs load

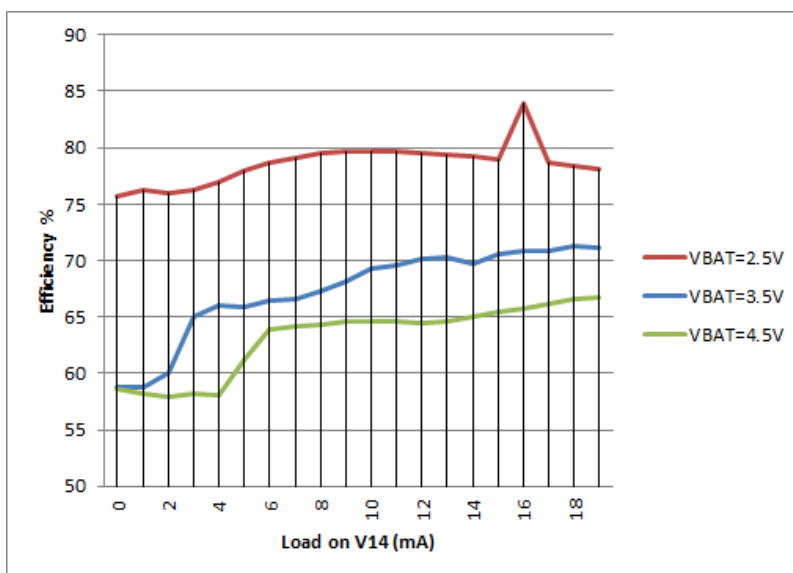

Figure 13: 1.4V rail DCDC efficiency vs load

1.2V and 1.4V efficiency is measured with no load on the 1.8V.

4.1.2 LDOs

Several LDOs are used to provide a stable power supply to all rails, when the SIMO DCDC is not active (e.g. in Sleep mode or during start up) or when the device is plugged onto a USB charger. Furthermore, bypassing the DCDC is also considered, when the external voltage on pin VBAT2 is at the edge of enabling an efficient step-down activity (i.e. < 2.3V).

Two low power LDOs (LDO_ret) one connected to VBUS and one to VBAT, provide power to the Vcont power line and hence to the LDO_sleep (which is a clamp actually). This LDO is responsible for providing the VDD supply during Sleep mode, which can be trimmed down to 0.85 V. This is basically the supply of the Always On power domain (PD_AON) which is always on, independently of active or any sleep mode.

In Sleep modes the retention LDOs might take over and make sure that the system is properly powered without the need of the DC-DC converter. The LDO_VBAT_RET provides power to the System supply line the LDO_SLEEP at Vcore, and LDO_IO_RET/LDO_IO_RET2 to the external 1.8 V power rails. There is no need to power the Vradio since it is not enabled in any of the sleep mode. The LDO_VBAT_RET and LDO_IO_RETx circuits are identical and operate in a sample & hold manner: They contain a reference voltage capacitance which is used to regulate the output voltage. However, due to leakage, this internal reference capacitor is discharged. To keep as stable voltage reference, a mechanism is built to start the Bandgap, sample the voltage reference in the LDOs and shut it

down again. This periodic operation is programmable in terms of timing with use of the SLEEP_TIMING_REG which counts sleep clock ticks.

In active mode, when external supply is between 1.7 V and 2.4 V and the DC-DC converter is bypassed (step-down conversion not feasible due to low voltage), the LDO_VBAT provides power to the Vsys line and the LDO_IO/LDO_IO2, LDO_Core and LDO_radio to the 1.8 V rails, the Vcore and the Vradio, respectively.

Finally, when the system is connected to a USB charger, pin VBUS is the source of the power instead of pin VBAT1/VBAT2. The same path is used as with VBAT2, but the LDO_USB is responsible for providing the System supply line with power. This LDO is automatically switched on as soon as a VBUS>VBAT1 voltage is sensed.

4.1.2.1 LDOs Loadstep Response

This section summarizes the loadstep response of the important LDOs of the PMU:

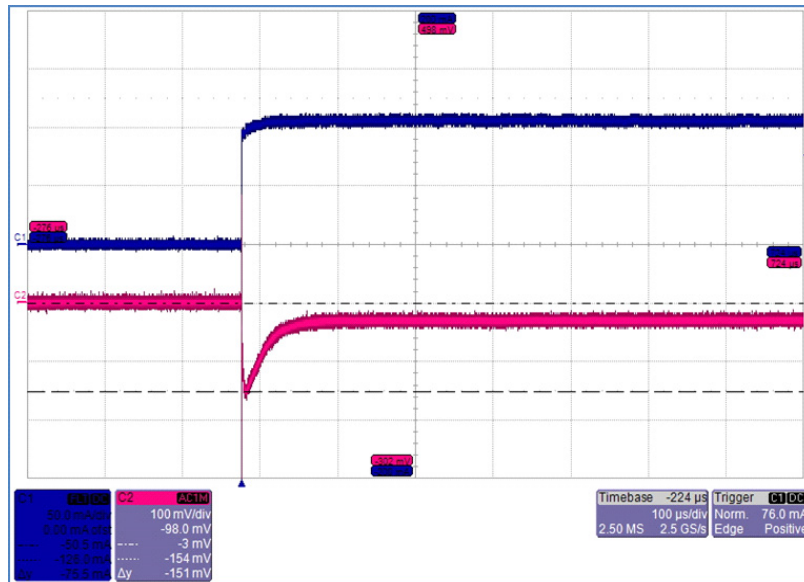

Figure 14: LDO_VBAT loadstep 0 to 100mA (Cload=4.7uF, Vout=3.3V)

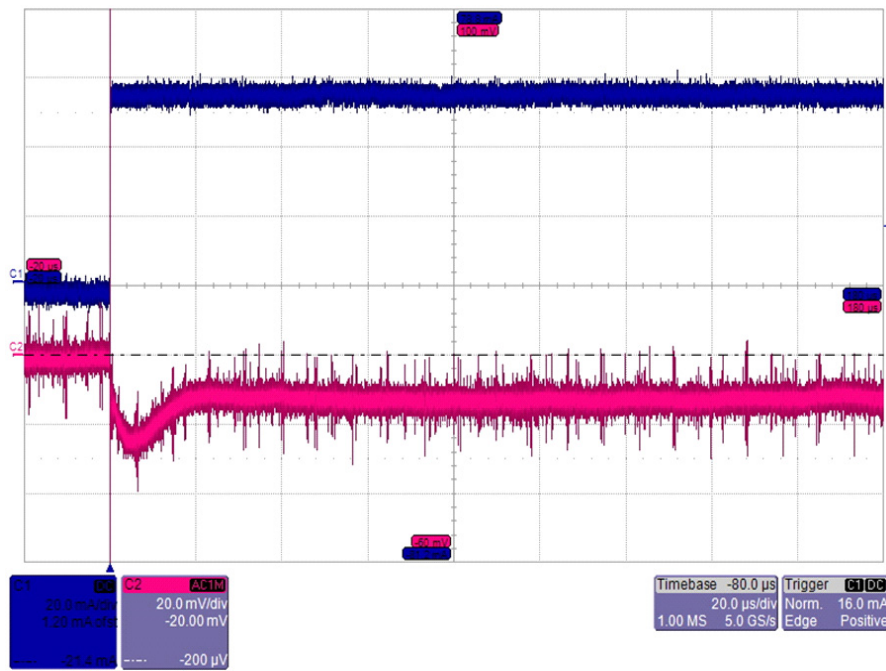

Figure 15: LDO_IO loadstep 0 to 60mA (Cload=10uF)

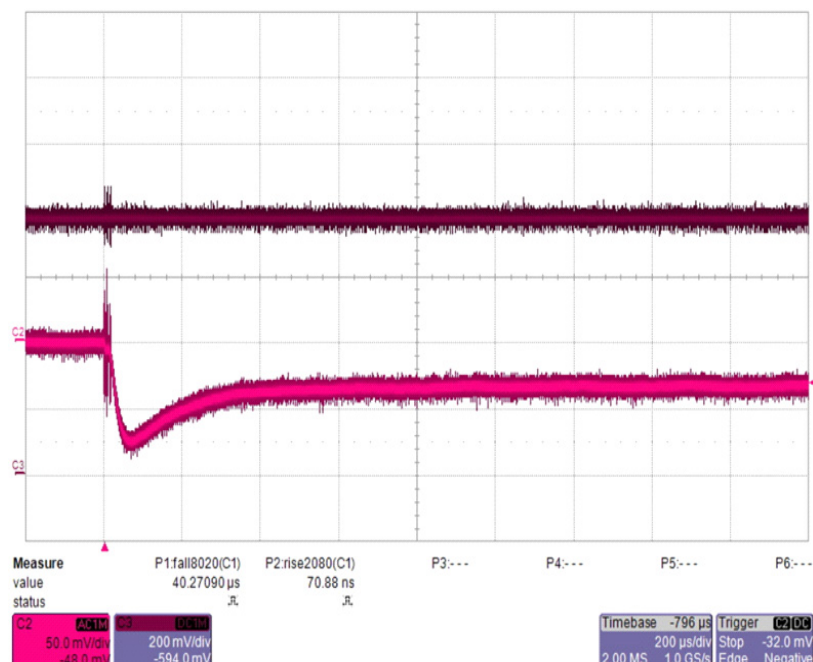

Figure 16: LDO_VBAT_RET loadstep 0 to 5mA (Cload=4.7uF, Vout=2.4V)

4.1.3 Switching from DC-DC to LDOs

The DCDC converter can supply the maximum load current for all four outputs down to a battery voltage of approximately 2.4 V. When the voltage drops below this, the 1.8 V outputs can no longer be supplied by the DCDC and current will have to be provided by LDO's. There are two methods for switching from DCDC to LDO's, one based on hardware and one based on software. Both modes use a special brown out, which signals that the battery voltage has dropped below 2.45 V (+/- 50 mV) as a detection mechanism. This brown out has to be enabled by setting BOD_CTRL2_REG[BOD_VBAT_EN]=1. In hardware mode, the DCDC controller will automatically disable the 1.8 V outputs when this brownout occurs and it will set the maximum current limits for the other outputs to a lower value (which is programmable). It will assert an internal signal that indicates that the converter is working in Low Voltage mode to signal that the 1.8 V LDO's have to be enabled. This mode can only be disabled by software in order to avoid the system oscillating between High and Low Voltage modes when the battery voltage is close to the brownout threshold.

The automatic Low Voltage mode can be fully disabled by DCDC_CTRL_0_REG[DCDC_BROWNOUT_LV_MOD E]=0. This also forces the converter back into High Voltage mode once it is operating in Low Voltage mode so when the battery voltage is once again sufficient the software needs to clear and then set the aforementioned register field to switch back to High Voltage

mode and re-enable automatic switching over to Low Voltage mode.

If automatic switching is disabled, software will have to handle the appropriate settings for a low battery. In order to alert the software to such a situation the DCDC controller can generate an interrupt upon a brownout event. The software can then handle all settings and it can choose to either clear and/or mask the interrupt (using the interrupt clear and interrupt mask registers respectively). Note that the interrupt and automatic Low Voltage mode settings are independent, so it is possible to generate interrupts when automatic Low Voltage mode is enabled.

The respective LDOs should be switched on before disabling the DCDC converter (i.e. just before entering a sleep mode). Each power rail (except Vcont and Vsys) is covered by both a DCDC output and an LDO. To switch off the DCDC, the user must enable the LDO_IO_RETx (if external components need to stay powered). If Vradio is required on, then LDO_RADIO should be activated as well.

4.1.4 PMU configurations in Sleep modes

Every power line can be supplied by either a DC-DC output or an LDO. Only Vcont and Vsys is not powered by a DC-DC output. There is quite a number of different ways of configuring the PMU to supply the internal rails as well as external devices, while in sleep mode, depending on the load, the sleep time etc. For supplying the Vsys rail a stable voltage level is needed hence the LDO_VBAT_RET has to be used, a sample-and-

hold type of LDO which samples the bandgap voltage on a regular basis and regulates accordingly. The regular wake-up is based on the SLEEP_TIMER_REG value.

The recommended power configuration is presented in the following table:

Table 10: Sleep PMU configuration

Power Rail	Power Configuration
Vcont	always on powered by LDO_RET
Vsys	LDO_VBAT_RET
Vflash	LDO_IO_RET
Vext	LDO_IO_RET2
Vcore	LDO_SLEEP
Vradio	OFF

There are many ways of configuring the PMU, how-

ever, there is one recommended configuration that covers all cases.

Vsys is powered by LDO_VBAT_RET, which is a sample and hold LDO, thus guaranteeing a stable voltage on this rail. This enables connecting external components on the V33 pin of the system. SLEEP_TIMER_REG has to be programmed with a value to trigger the period wakeup of the Bandgap. This covers systems with external components on 1.8V and/or 3.3V rails kept alive while the DA14681 is in Extended Sleep mode.

4.1.5 Wake/Power up - Sleep Timing

There are two HW controlled FSMs which run at power/wake up and when going to sleep as explained in section 3.4.1 and section 3.4.2 respectively. Their timing regarding the enabling/disabling of the various resources of the PMU is explained in the following figures:

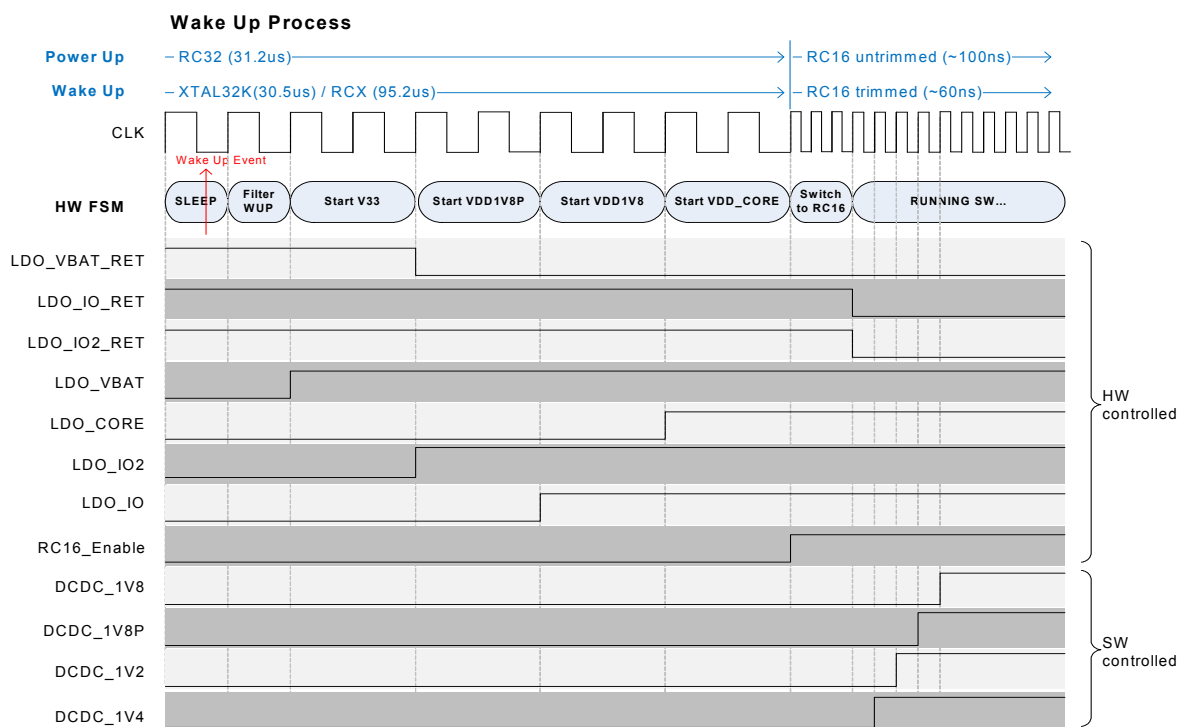

Figure 17: Wake/Power-Up timing and PMU operations

In the case of powering up the system, the HW FSM as depicted in Figure 3, enables the various LDOs while being clocked by the RC32K. Each LDO requires a certain amount of time to settle depending on the load of the power rail. The LDOs are ready within 12 clock cycles (or 380 us) and then the clock is switched to the RC16 which has not yet been trimmed, hence the frequency is near 10 MHz.

In the case of waking up from any of the sleep modes,

the HW FSM operates at either the RCX or the XTAL32K clock hence the actual frequency may vary from 11.7 kHz to 32,768 kHz. The FSM filters the wake up event at the first state (an interrupt coming from a GPIO or an internal timer) and then it performs the same steps as in the power up case. The only difference here is that the amount of time required for the LDOs to settle might be less then before since the sleep time might have been short enough to allow a total discharge of the capacitances, internally as well

as externally. However, do the frequency variation the wake up time might reach 1.2 ms if the RCX is used.

In both cases, as soon as the RC16 clock is enabled, the FSM hands control to the CPU. The CPU will start executing code from address 0x0. If it is a power up, the BootROM code resides at address 0x0. If it is a wake up, the RAM is remapped at address 0x0. The actual application code is responsible for starting the DC-DC controller by setting `DCDC_CTRL_0_REG[DCDC_MODE]=Active`. Furthermore, the respective rails might or might not be enabled by respectively programming the `DCDC_<rail>_ENABLE_xV` bits.

Preparing the system for any of the sleep modes, requires that the application switches back the clock to the RC16 and switches off the XTAL16M (see Figure 18). After executing the WFI command (which puts the

chip into sleep), the clock is switched to the `lp_clk` (RCX or XTAL32K) the retention LDOs are enabled (`LDO_VBAT_RET`, `LDO_IO_RET` and `LDO_IO_RET2`) and the core (`VDD`) voltage LDO is disabled so that the `LDO_sleep` takes over. The actual amount of clock cycles since the WFI is issued up to the point where the `lp_clk` starts and the FSM changes state is 7. Depending on whether a value has been programmed in the `SLEEP_TIMER_REG`, the system is automatically shortly waken up every so many ticks (`lp_clk`) to quickly sample the bandgap voltage and get back to sleep. The DC-DC and the `LDO_VBAT_RET` require a sample-and-hold operation, hence if these two elements are not part of the sleep strategy, `SLEEP_TIMER_REG` should be kept to 0. The overall FSM latency is 4 `lp_clk` clock cycles

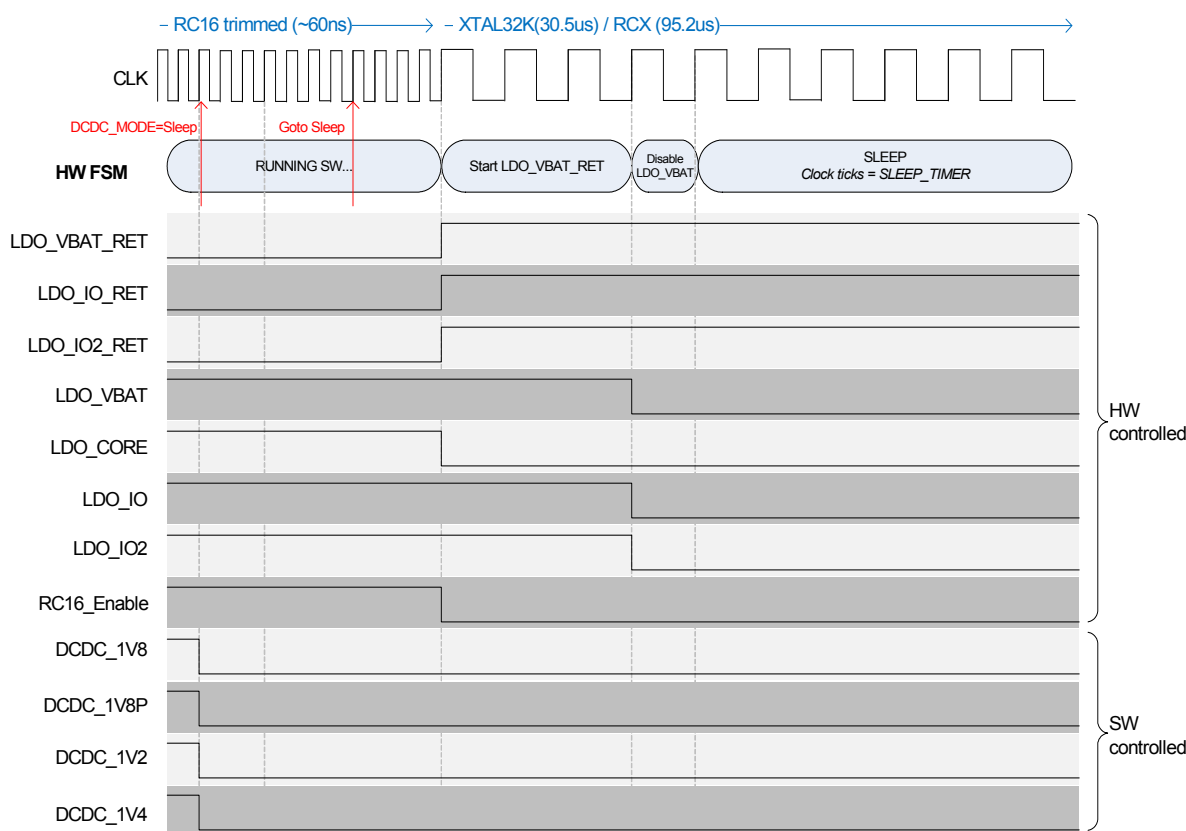

Figure 18: Goto Sleep timing and PMU operations

If the `SLEEP_TIMER_REG` is programmed to wake up the system for rails charging (DCDC operation) and bandgap sampling, then the timing of the HW FSM looks as illustrated in Figure 19. The state machine is clocked by the `lp_clk` and starts with enabling the Bandgap. On the next state, it enables the RC16 clock (`WPS_CLK`) and following that, a sampling of the Brown Out Detection circuit on the various power rail occurs (`WPS_BOD`). The sampling is performed with the `BOD_clk` at 1 MHz (see Figure 27).

Next state is dedicated to the DCDC converter (`WPS_SIMO`). This is when the charging of the different power rails will happen if the DCDC is set at sleep mode by programming the `DCDC_CTRL_0_REG[DCDC_MODE]` flag. During the last 3 states the sampling and hold of the bandgap voltage reference occurs, required by the `LDO_VBAT_RET`, the `LDO_IO_RET` and `LDO_IO_RET2`.

Charging of the DCDC rails as well as sample-and-hold functionality of the LDOs are both displayed in Figure 19 to allow illustrating the waveform for all cases. In reality, depending on the power configuration, only the

pre-defined resources will be part of the intermediate wake up FSM.

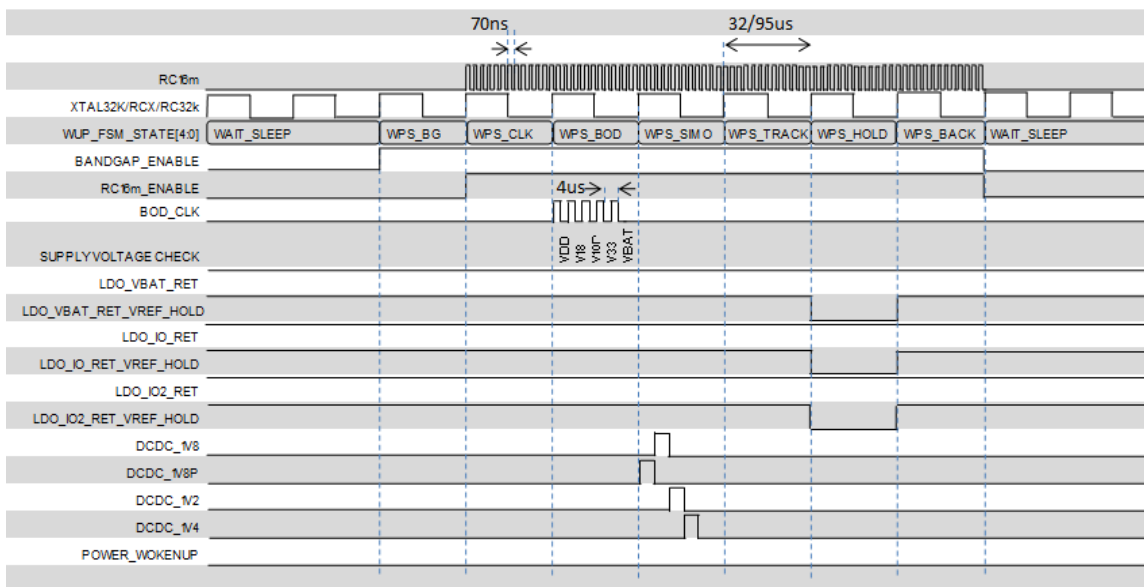

Figure 19: SLEEP_TIMER based wake up timing

4.1.6 Charger

The charging circuit operates as a constant current/constant voltage source. The control circuit keeps the charge voltage or the charge current at the predefined values (whichever of the two is reached first). The values can be changed via register CHARGER_CTRL1_REG.

The charge control circuit is initially supplied from pin VBUS. The complete charging circuit is powered down, when the VBUS voltage is low for more than 10 ms or by setting bit CHARGER_CTRL1_REG[CHARGE_ON] = 0. In a Li-ion application the charger is also disabled, when the voltage on pin NTC is in the “too hot” or “too cold” region.

Note that, the use of the charger requires P1_4 as a power pin and P1_6 for controlling the NTC if required (as shown in Figure 22).

Pre-Charging and Charging

The Charger is supporting pre-charging and normal charging as explained in the diagram below. The charger starts at constant current mode (CC) to get the battery voltage to the predefined voltage level. It then switches to constant voltage mode and continues until the current drops below the expected threshold indicating that the Battery has reached the charging limits.

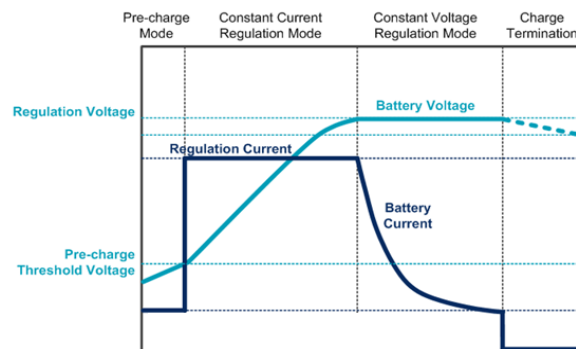

Figure 20: Pre-Charge and Charge Voltage/Current Diagram

The Charger circuitry supports a large range of current levels for pre-charge and charging. If the range is within 5 mA and 400 mA, then the respective level has to be programmed in the CHARGER_CTRL1_REG[CHARGE_CUR] field. If the range of pre-charge currents is between 0.2 mA and 15 mA then programming the CHARGER_CTRL2_REG[CHARGER_TEST]=0x6 in addition to the CHARGER_CTRL1_REG is required. This will divide the current level by ~27 hence produce sub-miliamps levels.

The pre-charge and charge state machine as imple-

mented in software is presented in the following flow chart:

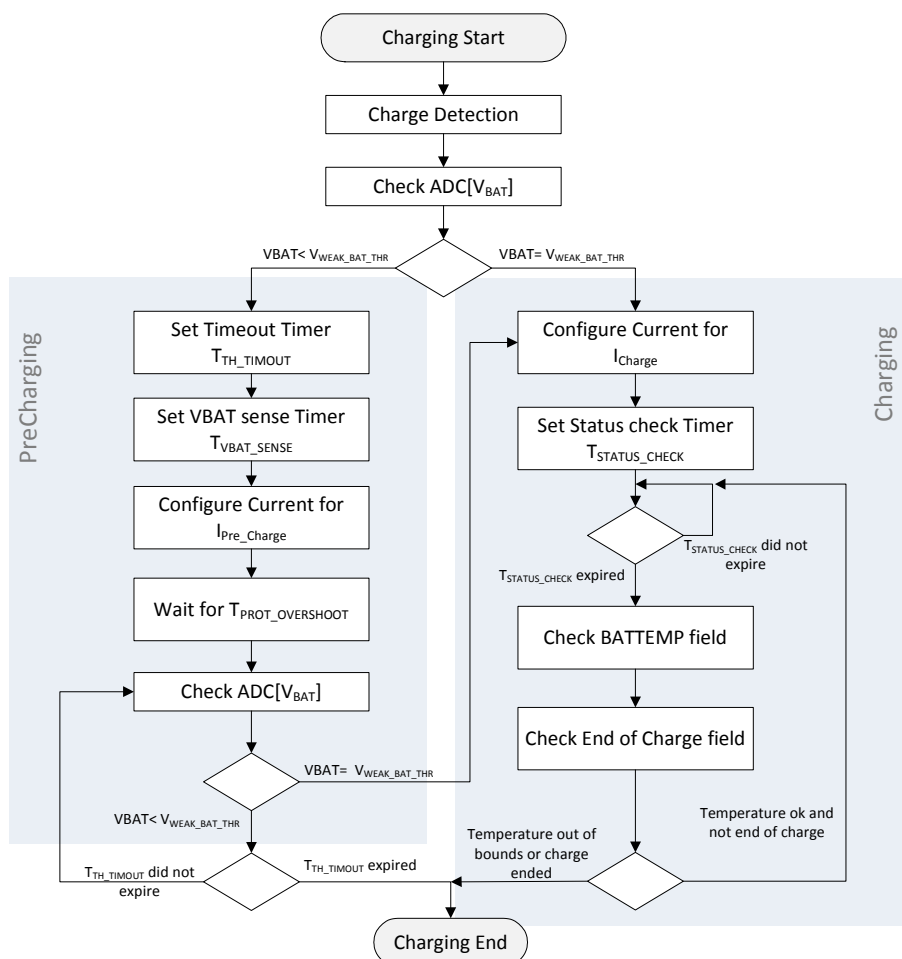

Figure 21: Pre-Charge and Charge SW FSM

The Charge detection is performed by HW according to the “Battery Charging Specification, Rev 1.2, December 2010”. There are several timers used in this flow chart as explained below:

- $T_{TH_TIMEOUT}$ is the time-out threshold which stops the pre-charging if voltage has not increased within a certain time interval due to possibly a bad battery.
- T_{VBAT_SENSE} defines the period of checking the voltage level of the battery via the ADC channel. It is set at 10 ms.
- $T_{PROT_OVERSHOOT}$ defines a programmable interval to avoid sampling a wrong VBAT voltage right after disabling a Battery protection IC. In these cases a small overshoot might be observed which could trick the sampling routine that battery is already charged, hence the charging sequence would be terminated. Default time is 10 ms.
- T_{STATUS_CHECK} is the time period after which, the

status bits of the charging circuitry are checked: `CHARGER_STATUS_REG[END_OF_CHARGE]` and `CHARGER_STATUS_REG[CHARGER_BATTEMP_OK]`

$V_{WEAK_BAT_THR}$ is the voltage threshold below which, a battery is considered as “weak” as explained in the BCS, Rev1.2 specification while I_{Charge} and I_{Pre_charge} the charging current limits configured as already explained.

Auto shut-off

The charger auto shut-off circuits for Li-ion/polymer batteries automatically switches off the charger circuit, when the NTC input voltage goes outside the specified voltage ranges as shown in Figure 22.

The charge disable function will be activated, when the voltage ratio (NTC voltage/P1_4 voltage) is below 1/2 (too hot) and above 7/8 (too cold).

The Auto shut-off control and status bits can be found in registers `CHARGER_CTR1_REG` and `CHARGER_STATUS_REG`.

R1 can be dimensioned as follows:

$$R1 = R_{NTC@T_{critical}}$$

E.g. if the NTC is 4.7 k Ω at $T_{critical} = \sim 40^{\circ}\text{C}$, R1 must also be 4.7 k Ω , charging will stop at the "too hot" limit. The "too cold" temperature is not critical and will in practice be around 0 $^{\circ}\text{C}$.

If the NTC auto shut-off feature is not required, bit `CHARGER_CTR1_REG[NTC_DISABLE]` must be set to '1'.

End Of Charge detection

This is an indicator when the charge current is decreased to 10% of the programmed value and can be read at

`CHARGER_STATUS_REG[END_OF_CHARGE]`. The charge cycle is not affected directly. This indicator can be used by higher-level control to manipulate the charge process.

Cold battery protection can be switched-off independently from the `NTC_DISABLE` control.

Non-rechargeable batteries

A 3.74 V charge level is provided to test for non-rechargeable NiMH batteries. For two NiMH batteries the maximum charging voltage is expected to be 3.4 V. When 3.74 V is selected and an ADC measurement indicates a quick rise above the 3.4 V level, most likely non-rechargeable batteries are present and the charger must be disabled.

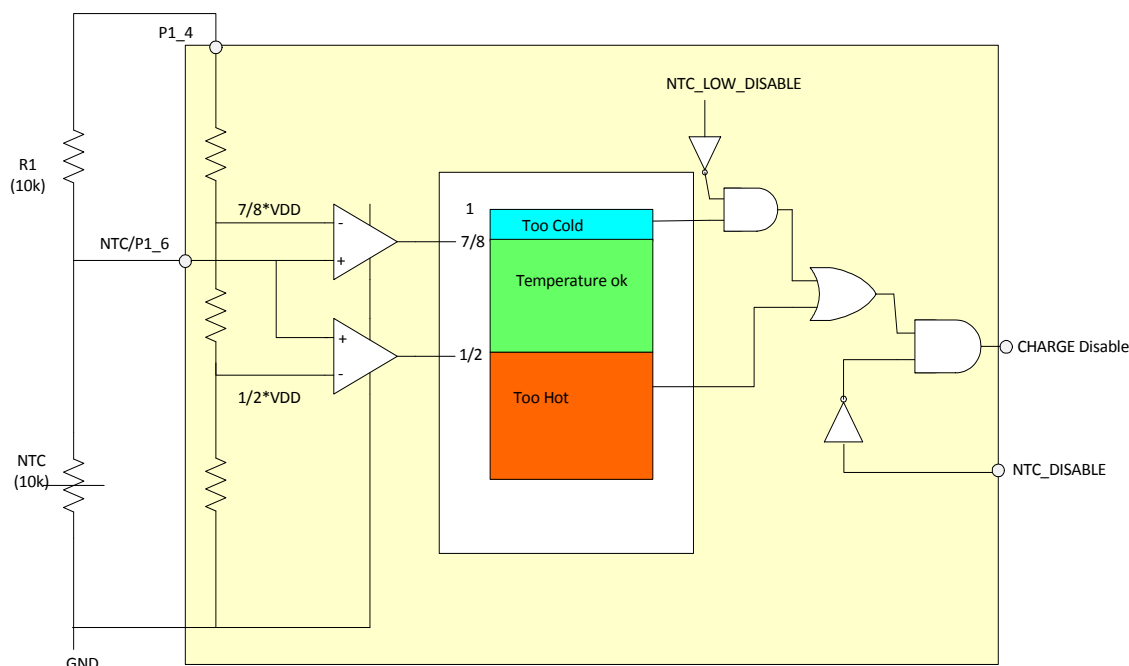

Figure 22: Charger auto shut-off circuit

4.1.7 Fuel gauge

The Fuel Gauge, State of Charge (SOC) circuit is used to accurately determine the actual amount of charge (Coulombs) in rechargeable batteries as well as the discharge state of non-rechargeable batteries. This information can be used as battery status indication to the user.

Features

- Coulomb Counter fuel gauge with high accuracy Sigma delta ADC 0.05% at 1A Max
- Integrates charge and discharge currents
- Measures average currents
- Offset cancelling by chopper amplifier
- Power saving mode with auto increment

Architecture

The Fuel Gauge measures integrates the current through the battery by measuring the voltage over a $0.1\ \Omega$ (typical) external resistor or PCB wire using SOCp and SOCn pins. Recommended settings will be based on this resistor value.

During operation (charge or discharge) the SOC continuously integrates the voltage on SOCn/SOCp using a Sigma Delta ADC and integrating counter which is

the time base for the 40 bits Fuel Gauge up/down counter. The chopper amplifier cancels any offset before passing it to the SD ADC. The integrated value is read via the SOC_CHARGE_CNTRx_REG ($x=1,2,3$) and the average current via the 16 bits SOC_CHARGE_AVG_REG (9 bit + sign + fractional).

All SOC_* registers can be read out via APB16 interface.

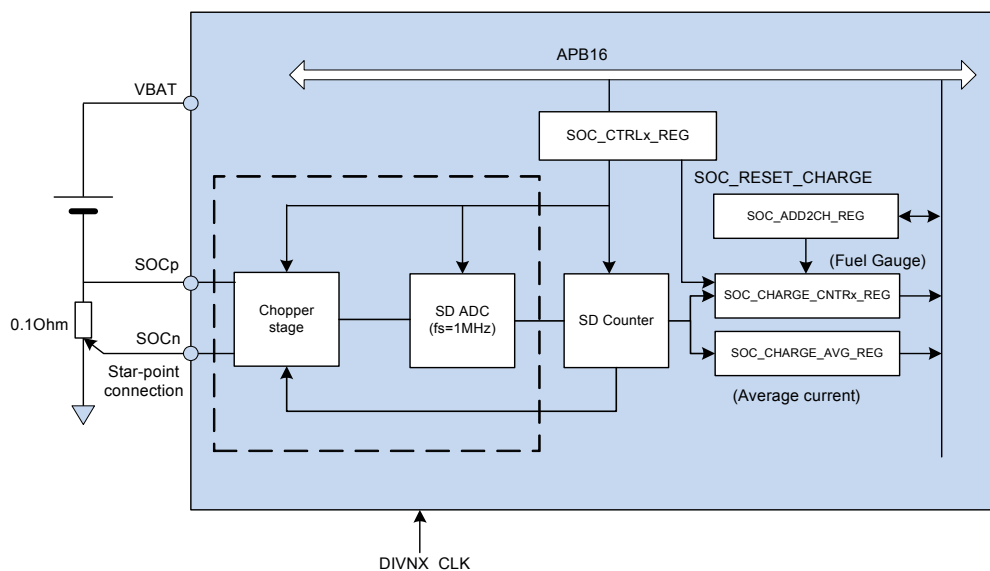

Figure 23: State of charge (SOC) circuit block diagram

Operation (rechargeable battery)

Figure 24 shows the Fuel Gauge Hardware/Software operation. The SOC_CHARGE_CNTRx_REG represents the actual amount of charge $Q = I \cdot t$ added or subtracted from the battery after the counter is reset with SOC_CTRL1_REG[SOC_RESET_CHARGE].

With the battery charger enabled, a fully charged battery will set bit CHARGER_STATUS_REG[END_OF_CHARGE]. At this point the SOC counter can be reset, starting to count down as soon as the battery is removed from the charger. A local variable "full_charge" is determined based on the battery capacity, aging and temperature parameters. The actual battery voltage is determined from a VBAT voltage measurement using the general purpose ADC. At the lowest operational battery level, the SOC_CHARGE_CNTRx_REG represents the battery capacity which will be negative at this point. The Current charge = full_charge - SOC counter value.

Reversely, if the counter is reset at the lowest battery voltage, the increasing counter represents the current actual battery charge.

At insertion of a new battery the MIN/MAX values of the counter are unknown, so the above described calibration procedure must be repeated.

Power saving mode

For power saving the SOC analog part can be disabled and the SOC_ADD2CH_REG will be used to decrement the SOC_CHARGE_CNTRx_REG at the default sample frequency of 1 MHz. The value of the SOC_ADD2CH_REG can be determined from the SOC_CHARGE_AVG_REG when not in power saving.

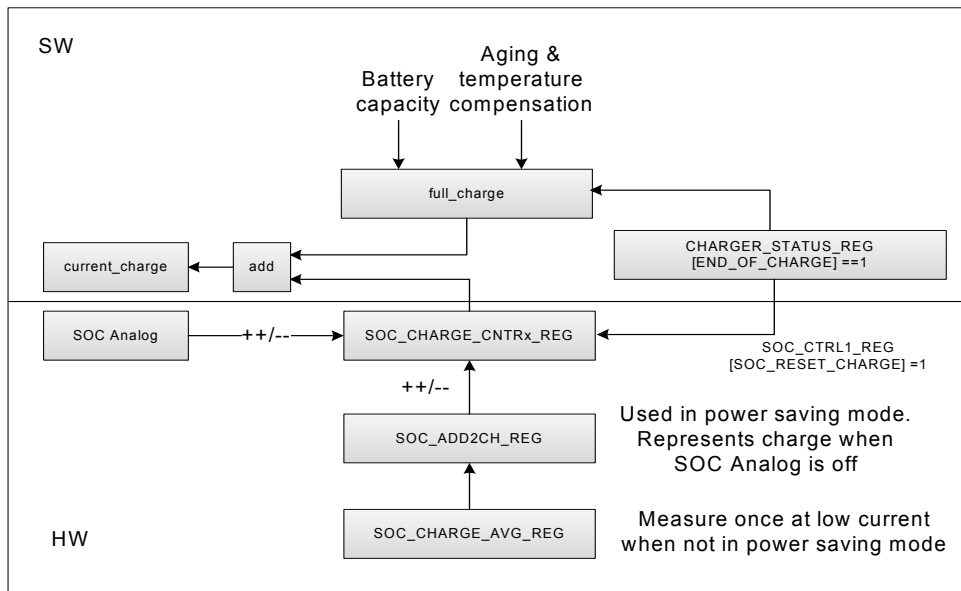

Figure 24: Fuel Gauge operation

4.1.8 USB charger detection

The USB controller has built-in hardware to determine the charger type to which it is connected. Depending on the charger type, battery state and USB connection state a defined current can be drawn from the charger.

- Charger type detection: Dedicated Charging Port (DCP), Charging Downstream Port (CDP), Standard Downstream Port, PS2 port and Proprietary charger
- Dead battery provision
- Compatible with various smartphone chargers

Features

- Complies to "Battery Charging Specification" Revision V1.2 December 7, 2010 (BC1.2)

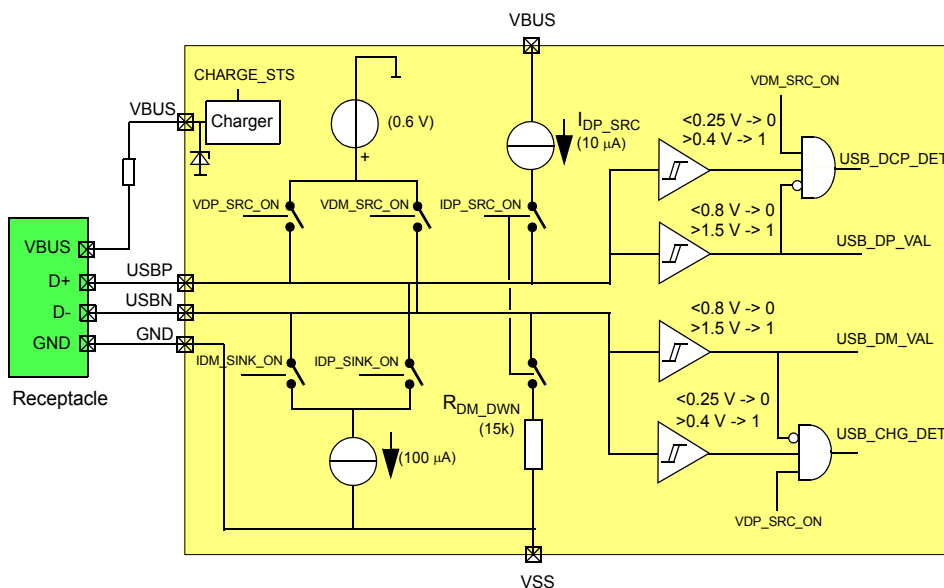

Figure 25: USB charger detection block diagram (BC1.2)

The USB interface supports the battery charging with the following hardware blocks as shown in [Figure 25](#).

- A voltage source of 0.6 V can be switched to USBP or USBN with USB_CHARGER_CTRL_REG bits VDP_SRC_ON resp. VDM_SRC_ON.
- A current sink of 100 μ A can be switched to USBP or USBN with USB_CHARGER_CTRL_REG bits IDP_SINK_ON resp. IDM_SINK_ON. (Note that internal logic prevents to both switches can be enable at the same time)
- A current source I_{DP_SRC} and R_{DM_DWN} can be enabled with USB_CHARGER_CTRL_REG[IDP_SRC_ON]
- A logic level Schmitt trigger for USBN, USBP read in USB_CHARGER_STAT_REG bits USB_DM_VAL, resp. USB_DP_VAL logic level (0: <0.8 V 1: >2 V)
- A comparator output CHG_DET read in USB_CHARGER_STAT_REG[USB_CHG_DET] to detect a level of $0.4\text{ V} < \text{USBN} < 1.5\text{ V}$ to indicate that a DCP or CDP is connected.
- A comparator output DCP_DET read in USB_CHARGER_STAT_REG[USB_DCP_DET] to detect a level of $0.4\text{ V} < \text{USBP} < 1.5\text{ V}$ to indicate that a DCP is connected.

Initially all bits of USB_CHARGER_CTRL_REG must be set to reset value '0'.

The presence of VBUS can be checked by reading bit ANA_STATUS_REG[VBUS_AVAILABLE].

Optionally, in case the receptacle's VBUS is connected to the CHARGE pin via a resistor, bit BAT_STATUS_REG[CHARGE_STS] is set when $V_{charge} > V_{ih_charge}$ (1.5 V). This value meets the VOTG_SESS_VLD value. With the keyboard interface configured to detect a level change of the CHARGE pin, bit KEY_STATUS_REG[0] is set and a KEYB_INT is generated. Optionally, an accurate value of VBUS can be determined with a resistor divider on VBUS to VSS, connected to one of the general purpose ADC inputs.

Detection negotiation

When a downstream port drops VBUS, the bus will discharge and ANA_STATUS_REG[VBUS_AVAILABLE] goes to 0.

Contact detection

If USB_CHARGER_CTRL_REG[IDP_SRC_ON] is set, bit USB_CHARGER_STAT_REG[USB_DP_VAL] indicates that the data pins make contact (see [Table 11](#)).

It is the responsibility of the SW to wait until the USBN and USBP contact bouncing has finished before the register is read.

Table 11: USBP, USBN contact detection

Port	USBP	USBN	USB_DP_VAL
Nothing connected	>1.5 V	0	1
Standard downstream	<0.8 V	0	0
Dedicated charger	<0.8 V	<0.8 V	0
Charging downstream	<0.8 V	<0.8 V	0

Primary charger detection

Primary charger detection is used to detect whether the downstream port has charging capabilities or not. The detection is initiated by setting bits USB_CHARGER_CTRL_REG[VDP_SRC_ON] and USB_CHARGER_CTRL_REG[IDM_SINK_ON]. This enables the voltage source V_{DP_SRC} on USBP and the current source I_{DM_SINK} on USBN. The measured levels on USBP and USBN shown in [Table 12](#) determine the value of bit USB_CHARGER_STAT_REG[USB_CHG_DET].

Table 12: Charger type detection

Port	USBP	USBN	USB_CHG_DET
Dedicated charger	0.6 V	>0.4 V <1.5 V	1
Charging downstream	0.6 V	First <0.25 V Then 0.6 V	0 (Note 1) then 1 after 1 ms to 20 ms
Standard downstream	0.6 V	<0.25 V	0
PS2	2 V	2 V	0

Note 1: After 20 ms a valid comparator signal is found, after 40 ms the comparator signal can be read in USB_CHG_DET.

Note that when the charger detection is done before the charging downstream port is enabled its V_{DM_SRC} (so before 20 ms) a standard downstream port is detected, which is safe but incorrect. After the V_{DM_SRC} has been enabled in the charging downstream port, a charger port is detected.

Secondary charger detection

Secondary charger detection can be used to distinguish a dedicated charger or a charging downstream port. The detection is initiated by setting bits `USB_CHARGER_CTRL_REG[VDM_SRC_ON]` and `USB_CHARGER_CTRL_REG[IDP_SINK_ON]`. This enables V_{DM_SRC} and I_{DP_SINK} . The difference between a DCP and a CDP is shown [Table 13](#).

Table 13: Secondary charger detection

Port	USBP	USBN	USB_DCP_DET
Dedicated charger	>0.4 V <1.5 V	0.6 V	1
Charging downstream	<0.25 V	0.6 V	0

Finally V_{DP_SRC} shall be enabled as defined in the Good Battery Algorithm.

Interrupts

The charger detection hardware can operate in polling mode or can generate a USB interrupt to the ARM Cortex™ M0. A change in one of the bits [3:0] of register `USB_CHARGER_STAT_REG` sets bits `USB_MAEV_REG[USB_CH_EV]` if the corresponding bits [7:4] are set to '1'. If `USB_CHARGER_STAT_REG` is read, bit `USB_CH_EV` interrupt is cleared. The interrupt "set" conditions have priority over the "clear" condition of the read access.

Once VBUS is inserted, CHARGE generates a `KEYB_INT`. A debounce timer for Contact Detection and wait time to detect a standard downstream port must be done by software polling or by using system timer interrupts `SWTIM_INT`.

USB V1.1 compatibility

In USB V1.1 the integrated USBP and USBN resistors were used for a dedicated charger detection. Although not very convenient, these resistors can still be used to force High/Low levels on the USB lines.

Smartphone charger detection

The battery charger detection circuit is able to detect smartphone chargers with characteristics shown in [Table 14](#).

Table 14: Smartphone charger characteristics

USBP	USBN	Load current
2.0 V	2.0 V	up to 500 mA
2.0 V	2.8 V	up to 1 A
2.8 V	2.0 V	up to 2 A
2.8 V	2.8 V	Not defined

Table 15: Smartphone charger detection

USBP/ USBN	USB_DP_VAL / USB_DM_VAL	USB_DP_VAL2 / USB_DM_VAL2	Voltage
2 V	1	0	>1.5 V <2.3 V
2.8 V	1	1	>2.5 V

5 Reset

The DA14681 comprises an RST pad which is active HIGH. It contains an RC filter for spike suppression. It also contains a 25 kΩ pull-down resistor. The typical latency of the RST pad is in the range of 2 μs.

Furthermore, a separate programmable Brown-Out block will issue a Power On Reset (POR) upon voltage reaching the minimum threshold on each of the three main power rails of the system.

Features

- RC spike filter on RST to suppress external spikes (400 kΩ, 2.8 pF)
- Three different reset lines (SW, HW and POR)
- Power On Reset (POR) issued if voltage threshold reached on VDD, VDD1v8 or V33 rails
- Programmable POR voltage threshold for the VDD rail in sleep (0.7V or 0.8V)
- Configurable POR enables for the VDD1v8 and the VDD3v3 rails

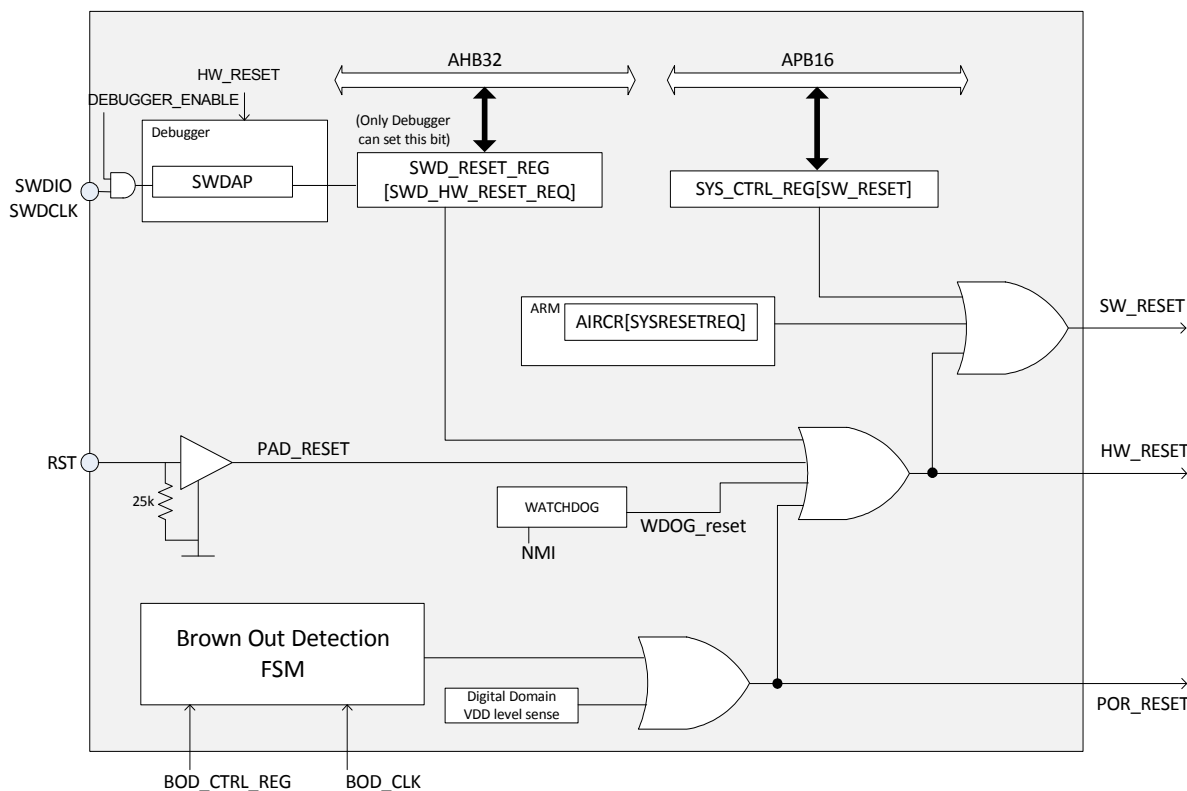

Figure 26: Reset and Brown-Out block diagram

5.1 POR, HW AND SW RESET

The Power On Reset (POR) signal is generated internally and will release the system’s flip-flops as soon as the VDD voltage crosses the minimum threshold value at 0.65 V and the Brown-Out Detection FSM senses the various internal voltage levels to be higher than the programmed thresholds as explained in section 5.2. The POR resets everything in the chip.

There are two other main reset signals in the DA14681, namely:

- the HW reset which is basically triggered by the RST pad, the Watchdog expiration, the POR and the debugger (by writing SWD_RESET_REG)

- the SW reset which is triggered by application software, writing the SYS_CTRL_REG[SW_RESET] bit, the HW reset, and a special ARM command.

The HW reset can also be automatically activated upon waking up of the system from an Extended Sleep or Deep Sleep mode by programming bit PMU_CTRL_REG[RESET_ON_WAKEUP]. The HW reset will basically run the cold startup sequence and the BootROM code will be executed.

The SW reset is the logical OR of a signal from the ARM CPU (triggered by writing SCB -> AIRCR = 0x05FA0004) and the SYS_CTRL_REG[SW_RESET] bit. This is mainly used to reboot the system after the base address has been remapped.

All registers are reset by POR, a few are not reset by the HW reset signal, and even more are not reset by the SW reset. These registers are listed in the following table:

Table 16: Reset signals and registers

Reset by POR only	Reset by HW reset	Reset by writing to the SW_RESET bit only
all DCDC_* registers	all QSPIC_* registers	The rest of the register file
BANDGAP_REG	all PLL_* registers	
AON_SPARE_REG	all CACHE_* registers except for CACHE_MRM_* registers	
SYS_STAT_REG	All other OTPC_* registers	
ANA_STATUS_REG	BLE_CNTL2_REG BLE_EM_BASE_REG	
BOD_STATUS_REG	DEBUG_REG. DEBUGS_FREEZE_EN	
OTPC_MODE_REG.MODE OTPC_NWORDS_REG OTPC_TIM1_REG OTPC_TIM2_REG	CLK_AMBA_REG[12:0] CLK_FREQ_TRIM_REG CLK_RADIO_REG CLK_CTRL_REG PMU_CTRL_REG SYS_CTRL_REG CLK_32K_REG CLK_16M_REG CLK_RCX32K_REG TRIM_CTRL_REG BOD_CTRL_REG BOD_CTRL2_REG LDO_CTRL1_REG LDO_CTRL2_REG SLEEP_TIMER_REG POWER_CTRL_REG	

5.2 BROWN OUT DETECTION

The DA14681 contains a brown out detection circuitry which is based on sensing selected voltages in the chip every clock cycle. If one of the voltages is found to be below the pre-configured threshold, then a POR is issued.

The BOD FSM is running on the BOD_clk which is 1 MHz coming from a fixed division of the RC16 clock by 16. The pulses generated for moving from one state to another are 25% duty cycled, hence 250 kHz.

The threshold values for the comparison are configured in the BOD_CTRL_REG. Issuing a POR upon sensing a lower voltage than the pre-defined threshold is controlled by BOD_CTRL2_REG[BOD_RESET_EN]. Furthermore, each sensed voltage can be masked out with use of the BOD_CTRL2_REG enable bits. The FSM steps are the following:

1. BOD_IDLE: idle state. It will proceed to the next state when the system wakes up.
2. BOD_VDD: senses the VDD voltage. it will issue a HW reset if the respective bits are set.
3. BOD_V18: senses the VDD1V8 voltage. it will

issue a HW reset if the respective bits are set.

4. BOD_V18P: senses the VDD1V8P voltage. it will issue a HW reset if the respective bits are set.
5. BOD_V33: senses the V33 voltage. it will issue a HW reset if the respective bits are set.
6. BOD_VBAT: senses the VBAT1 voltage. it will not issue a HW reset. Instead, it will trigger the DCDC_IRQ line as soon as the VBAT1 voltage reaches 2.45V. The reason is to notify SW that from this point and below, DCDC is not providing better efficiency than the LDOs, hence SW should switch the PMU operation to the LDO_VBAT.
7. BOD_READY: The RC16 will be turned off during this state and the state machine is set back to BOD_IDLE.

During the extended sleep mode, the BOD FSM is only triggered if the SLEEP_TIMER_REG is programmed with a specific value different than zero. The timing is explained in [Figure 19](#) of [section 4](#).

6 Clock generation

6.1 CLOCK TREE

The generation of the system's clocks is described in detail in the following figure:

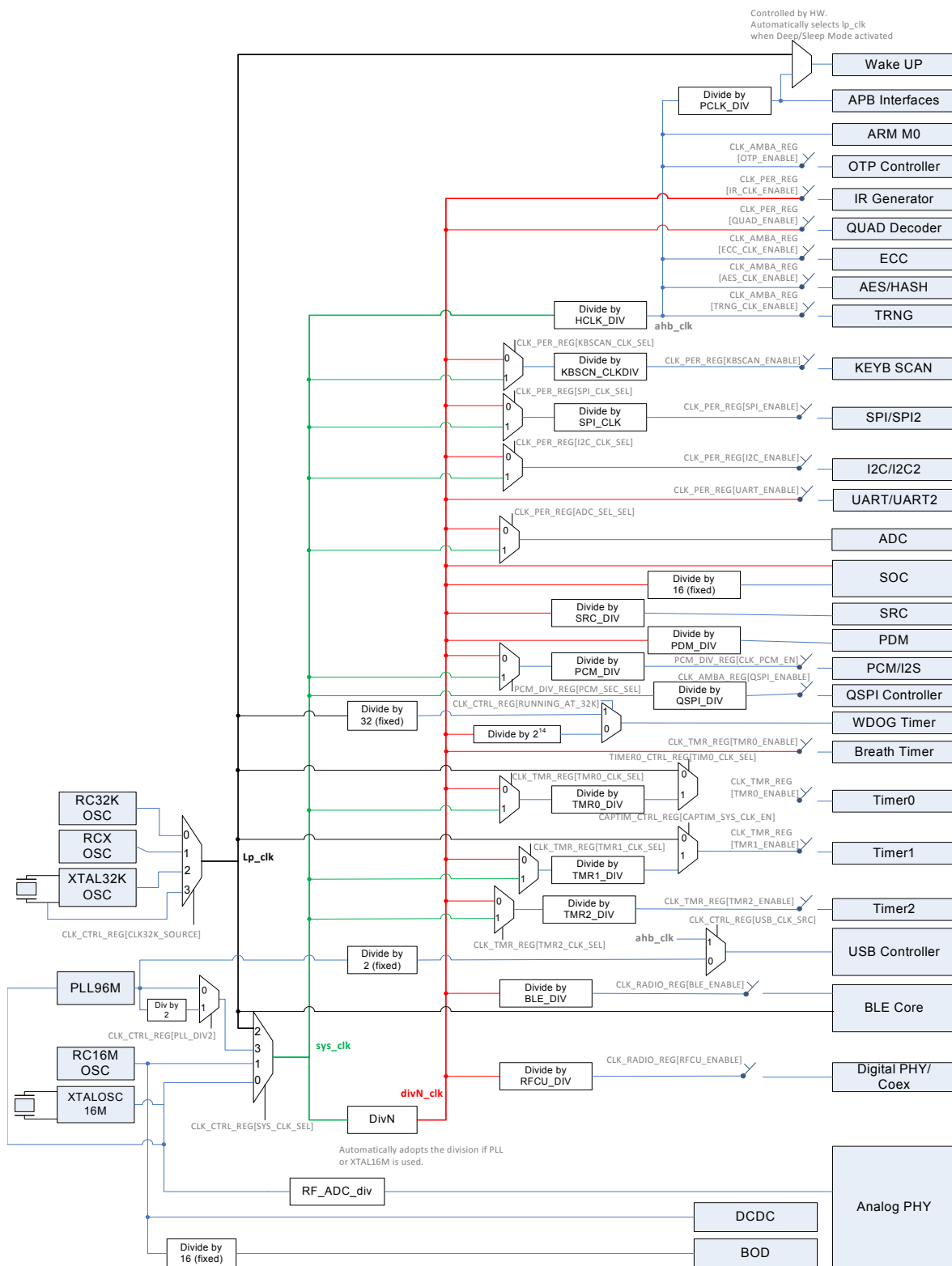

Figure 27: Clock tree diagram

The diagram depicts the possible clock sources as well as all different divisions and multiplexing paths towards the generation of each block's clock. Furthermore, the required registers that have to be programmed are also designated on the same diagram.

There are some main clock lines which are of interest:

- **lp_clk** (black bold line): this is the low power clock used for the sleep modes and can only be either the RCX, the RC32K or the XTAL32K.
- **sys_clk** (green line): this is the system clock, used for the AMBA clock (hclk) which runs the CPU the memories and the bus. This clock sources can be any oscillator, the PLL or even an externally supplied digital clock.
- **divn_clk** (red line): this is a clock which automatically adjusts the division factor on the sys_clk to always generate 16 MHz. This enables the dynamic activation of the PLL to provide more processing power at the CPU, without affecting the operation of blocks designed for 16 MHz.

6.2 CRYSTAL OSCILLATORS

The Digital Controlled Xtal Oscillator (DXCO) is a Pierce configured type of oscillator designed for low power consumption and high stability. There are two such crystal oscillators in the system, one at 16 MHz (XTAL16M) and a second at 32.768 kHz (XTAL32K). The 32.768 kHz oscillator has no trimming capabilities and is used as the clock of the Extended/Deep Sleep modes. The 16 MHz oscillator can be trimmed.

The principle schematic of the two oscillators is shown in Figure 28: below. No external components are required other than the crystal itself. If the crystal has a case connection, it is advised to connect the case to ground.

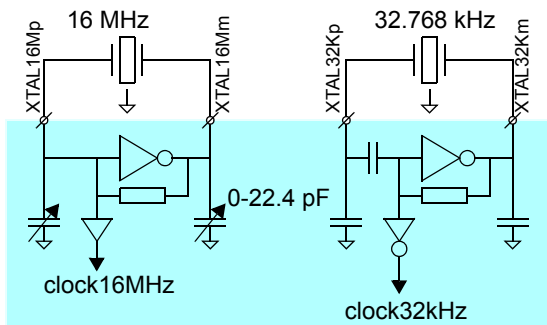

Figure 28: Crystal oscillator circuits

6.2.1 Frequency control (16 MHz crystal)

Register CLK_FREQ_TRIM_REG controls the trimming of the 16 MHz crystal oscillator. The frequency is

trimmed by two on-chip variable capacitor banks. Both capacitor banks are controlled by the same register.

The capacitance of both variable capacitor banks varies from minimum to maximum value in 2048 equal steps. With CLK_FREQ_TRIM_REG = 0x000 the maximum capacitance and thus the minimum frequency is selected. With CLK_FREQ_TRIM_REG = 0x7FF the minimum capacitance and thus the maximum frequency is selected.

The eight least significant bits of CLK_FREQ_TRIM_REG directly control eight binary weighted capacitors, as shown in Figure 29. The three most significant bits are decoded according to Table 17. Each of the seven outputs of the decoder controls a capacitor (value is 256 times the value of the smallest capacitor).

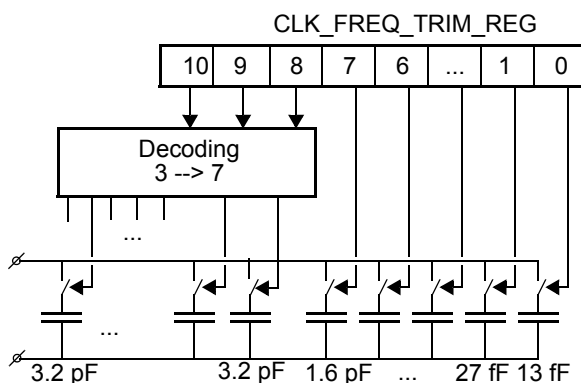

Figure 29: Frequency trimming

Table 17: CLK_FREQ_TRIM_REG Decoding 3 --> 7

Input[2:0]			Output[6:0]						
2	1	0	6	5	4	3	2	1	0
0	0	0	0	0	0	0	0	0	1
0	0	1	0	0	0	0	0	0	1
0	1	0	0	0	0	0	0	1	1
0	1	1	0	0	0	0	1	1	1
1	0	0	0	0	0	1	1	1	1
1	0	1	0	0	1	1	1	1	1
1	1	0	0	1	1	1	1	1	1
1	1	1	1	1	1	1	1	1	1

6.2.2 Automated trimming and settling notification

There is provision in the DA14681 for automating the actual trimming of the 16 MHz crystal oscillator. This is a special hardware block that realizes the XTAL trimming in a single step. Notification about the XTAL oscillator being settled after applying the trim value is also

provided in form of an interrupt, namely the `xtal16rdy_irq` line.

and signalling that the oscillator is settled is described in the following figure:

The automated mechanism for applying the trim value

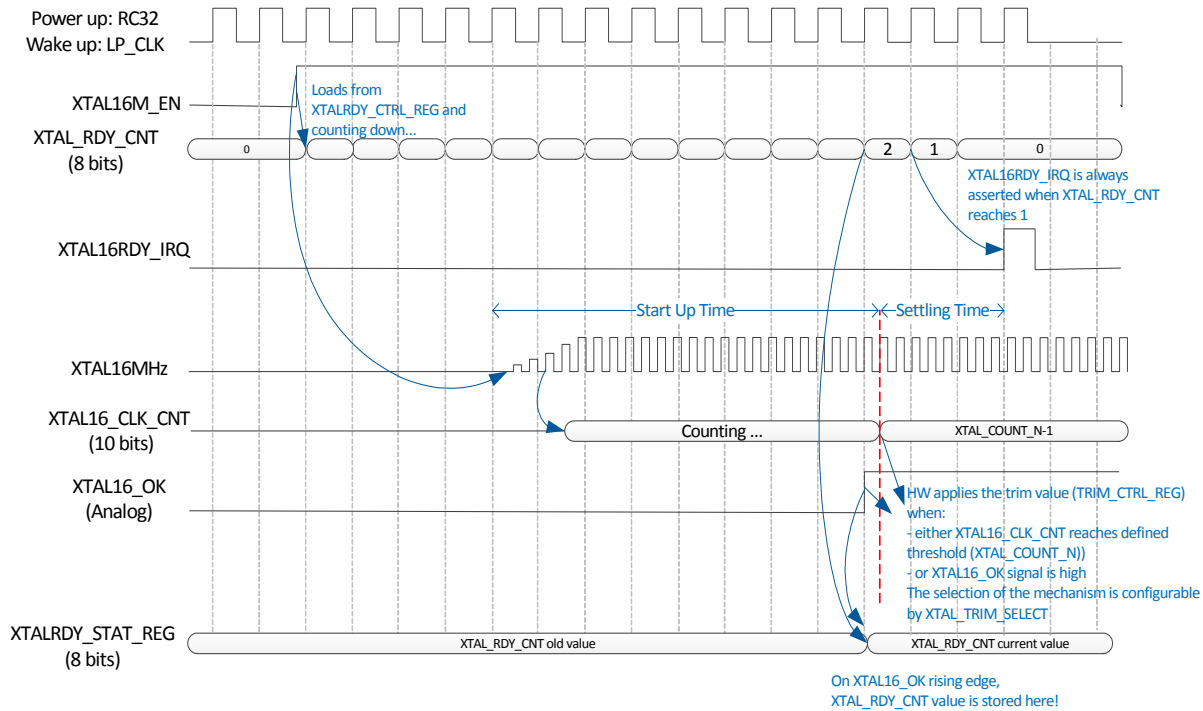

Figure 30: Automated mechanism for XTAL16M trim and settling

The `XTALRDY_IRQ` is always triggered as soon as an internal counter reaches the value 1 counting down from starting value programmed at `XTALRDY_CTRL_REG`. This counter runs on the RC32 clock if the system is powering up, or the sleep clock if the system is waking up. Enabling of the XTAL16M oscillator is done by HW. There are two intervals until the interrupt notifies the CPU that the XTAL16 can be used:

- The Start-Up, where the XTAL16M oscillator is slowly converging towards the initial frequency of the crystal. This section ends with the application of the trim value to achieve a <50ppm, 16 MHz clock.
- The Settling, where the oscillator settles to the preferred frequency after the application of the trim value

There are two ways of deciding when the start-up section ends. This decision is controlled by `TRIM_CTRL_REG[XTAL_TRIM_SELECT]` bitfield:

- Use an analog filter which asserts an internal signal (`XTAL16_OK`)
- Use a digital counter which counts `TRIM_CTRL_REG[XTAL_COUNT_N]` number of XTAL16M clocks

In any case, the trim value is applied by HW. At the rising edge of the `XTAL16_OK` signal, the interrupt coun-

ter current value (`XTAL_RDY_CNT`) is stored in a shadow register `XTALRDY_STAT_REG`. Note that, this register keeps the previous value and will not be reset unless a HW reset occurs.

The settling section usually takes not more than 5 to 10 clock cycles. Using the above, fine tuning and reducing the XTAL16 settling latency is feasible.

The `XTAL16_TRIM_READY` bit indicates that the trimming process is done. This bit is reset after the XTAL16 oscillator is disabled (turning off the system power domain) if `XTAL_TRIM_SELECT= 00` or `01`.

6.3 RC OSCILLATORS

There are 3 RC oscillators in the DA14681: one providing 16 MHz (RC16M), one providing 32 kHz (RC32K) and one providing a frequency in the range of 11.7 kHz (RCX).

The 16 MHz RC oscillator is powered by the Digital LDO i.e. the $V_{DD} = 1.2$ V which is available for the core logic during Active or Sleep Mode. The output clock is significantly slower than 16 MHz if untrimmed and is used to clock the CPU and the digital part of the chip during power up or wake up, while the XTAL16M oscillator is settling.

The simple RC oscillator (RC32K) operates on $V_{DD} = 1.2$ V and provides 32 kHz. The main usage of the RC32K oscillator is for internal clocking during

power up or startup. It clocks the HW state machine which brings up the power management system of the chip.

The enhanced RC oscillator (RCX) provides a stable 11.7 kHz. The RCX oscillator can be used to replace the 32.768 kHz crystal, since it has a precision of < 500 ppm, while its output frequency is quite stable over temperature.

6.3.1 Frequency calibration

The output frequency of the 32 kHz crystal oscillator and the three RC-oscillators can be measured relative to the DivN clock using the on-chip reference counter.

The measurement procedure is as follows:

- REF_CNT_VAL = N (the higher N, the more accurate and longer the calibration will be)
- CLK_REF_SEL_REG[REF_CLK_SEL] = 0 (RC32K) or CLK_REF_SEL_REG[REF_CLK_SEL] = 1 (RC16M) or CLK_REF_SEL_REG[REF_CLK_SEL] = 2 (XTAL32) or CLK_REF_SEL_REG[REF_CLK_SEL] = 3 (RCX)
- CLK_REF_SEL_REG[REF_CAL_START] = 1 Start the calibration
- Wait until CLK_REF_SEL_REG[REF_CAL_START] = 0
- Read CLK_REF_VAL_H_REG and CLK_REF_VAL_H_REG = M (32-bits values)
- Frequency = (N/M) * 16 MHz

In the case of using the RCX as a sleep clock, the frequency calibration should be implemented on each active time of a connection interval to guarantee correct operation.

6.4 PLL

This low power PLL multiplies the XTAL16M clock to produce a 96 MHz clock with 1% precision within a few us reaching 200 ppm precision in 30 us.

Changing the system's clock in to the PLL output can be done dynamically without affecting the operation of the chip. Its main purpose is to:

- Provide a divided by 2, 48 MHz required for the operation of the USB Controller
- Provide more processing power to the CPU, enabling 80 dMIPS, for computational hungry applications

This PLL dissipates 1.2 mA when operating at 96 MHz while the leakage current can reach 1 uA when the PLL is disabled.

7 ARM Cortex M0

The Cortex-M0 processor is a 32-bit Reduced Instruction Set Computing (RISC) processor with a von Neumann architecture (single bus interface). It uses an instruction set called Thumb, which was first supported in the ARM7TDMI processor; however, several newer instructions from the ARMv6 architecture and a few instructions from the Thumb-2 technology are also included. Thumb-2 technology extended the previous Thumb instruction set to allow all operations to be carried out in one CPU state. The instruction set in Thumb-2 includes both 16-bit and 32-bit instructions; most instructions generated by the C compiler use the 16-bit instructions, and the 32-bit instructions are used when the 16-bit version cannot carry out the required operations. This results in high code density and

avoids the overhead of switching between two instruction sets.

In total, the Cortex-M0 processor supports only 56 base instructions, although some instructions can have more than one form. Although the instruction set is small, the Cortex-M0 processor is highly capable because the Thumb instruction set is highly optimized.

Academically, the Cortex-M0 processor is classified as load-store architecture, as it has separate instructions for reading and writing to memory, and instructions for arithmetic or logical operations that use registers.

A simplified block diagram of the Cortex-M0 is shown in Figure 31.

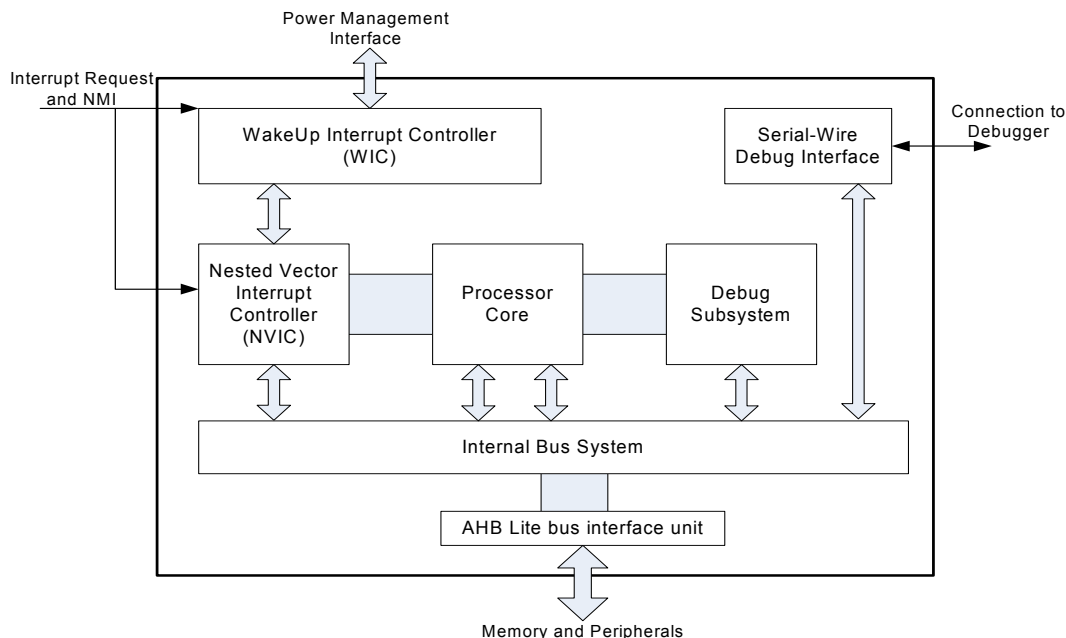

Figure 31: ARM Cortex M0 Block Diagram

Features

- Thumb instruction set. Highly efficient, high code density and able to execute all Thumb instructions from the ARM7TDMI processor.
- High performance. Up to 0.9 DMIPS/MHz (Dhrystone 2.1) with fast multiplier.
- Built-in Nested Vectored Interrupt Controller (NVIC). This makes interrupt configuration and coding of exception handlers easy. When an interrupt request is taken, the corresponding interrupt handler is executed automatically without the need to determine the exception vector in software.
- Interrupts can have four different programmable priority levels. The NVIC automatically handles nested interrupts.
- The design is configured to respond to exceptions (e.g. interrupts) as soon as possible (minimum 16 clock cycles).
- Non maskable interrupt (NMI) input for safety critical systems.
- Easy to use and C friendly. There are only two modes (Thread mode and Handler mode). The whole application, including exception handlers, can be written in C without any assembler.
- Built-in System Tick timer for OS support. A 24-bit timer with a dedicated exception type is included in the architecture, which the OS can use as a tick timer or as a general timer in other applications without an OS.
- SuperVisor Call (SVC) instruction with a dedicated SVC exception and PendSV (Pendable SuperVisor

service) to support various operations in an embedded OS.

- Architecturally defined sleep modes and instructions to enter sleep. The sleep features allow power consumption to be reduced dramatically. Defining sleep modes as an architectural feature makes porting of software easier because sleep is entered by a specific instruction rather than implementation defined control registers.
- Fault handling exception to catch various sources of errors in the system.
- Support for 32 interrupts.
- Little endian memory support.
- Wake up Interrupt Controller (WIC) to allow the processor to be powered down during sleep, while still allowing interrupt sources to wake up the system.
- Halt mode debug. Allows the processor activity to stop completely so that register values can be accessed and modified. No overhead in code size and stack memory size.
- CoreSight technology. Allows memories and peripherals to be accessed from the debugger without halting the processor.
- Supports Serial Wire Debug (SWD) connections. The serial wire debug protocol can handle the same debug features as the JTAG, but it only requires two wires and is already supported by a number of debug solutions from various tools vendors.
- Four (4) hardware breakpoints and two (2) watch points.
- Breakpoint instruction support for an unlimited number of software breakpoints.
- Programmer's model similar to the ARM7TDMI processor. Most existing Thumb code for the ARM7TDMI processor can be reused. This also makes it easy for ARM7TDMI users, as there is no need to learn a new instruction set.

7.1 SYSTEM TIMER (SYSTICK)

The Cortex-M0 System Timer (SysTick) can be configured for using 2 different clocks. The SysTick Control & Status (STCSR) register specifies which clock should be used by the counter.

STCSR[CLKSOURCE]=0; use the (fixed) external reference clock STCLKEN of 1 MHz.

STCSR[CLKSOURCE]=1; use the (HCLK_DIV dependent) processor clock SCLK (e.g. 2, 4, 8 or 16 MHz).

The default SysTick Timer configuration will be using the (fixed) external reference clock STCLKEN (STCSR[CLKSOURCE]=0). When necessary, higher clock frequencies can be used with STCSR[CLKSOURCE]=1 but the software should take the HCLK_DIV dependent core clock SCLK into account w.r.t. the timing.

7.2 WAKEUP INTERRUPT CONTROLLER

The Wakeup Interrupt Controller (WIC) is a peripheral that can detect an interrupt and wake the processor from deep sleep mode. The WIC is enabled only when the DEEPSLEEP bit in the SCR is set to 1 (see System Control Register on page 4-16 of the Cortex-M0 User Guide Reference Material).

The WIC is not programmable, and does not have any registers or user interface. It operates entirely from hardware signals. When the WIC is enabled and the processor enters deep sleep mode, the power management unit in the system can power down most of the Cortex-M0 processor. This has the side effect of stopping the SysTick timer. When the WIC receives an interrupt, it takes a number of clock cycles to wakeup the processor and restore its state, before it can process the interrupt. This means interrupt latency is increased in Deep Sleep mode.

7.3 REFERENCE

For more information on the ARM Cortex M0, see a.o. the ARM documents listed in [Table 18](#).

Table 18: ARM documents list

	Document title	ARM Document number
1	Cortex™-M0 User Guide Reference Material	ARM DUI 0467B (available on the ARM website)
2	Cortex™-M0 r0p0 Technical Reference Manual	ARM DDI 0432C (available on the ARM website)
3	ARMv6-M Architecture Reference Manual	ARM DDI 0419C (can be downloaded by registered ARM customers)

7.4 INTERRUPTS

This section lists all 32 interrupt lines, except the NMI interrupt, and describes their source and functionality. The overview of the interrupts is illustrated in the following table:

Table 19: Interrupt list

IRQ number (inherent priority)	IRQ name	Description
0	ble_wakeup_lp_irq	Wakeup from Extended Sleep by BLE
1	ble_gen_irq	BLE Interrupt. Sources: - finertgtim_irq: Fine Target Timer interrupt generated when Fine Target timer expired. Timer resolution is 625µs base time reference - grosstgtim_irq: Gross Target Timer interrupt generated when Gross Target timer expired. Timer resolution is 16 times 625µs base time reference - cscnt_irq: 625µs base time reference interrupt, available in active modes - slp_irq: End of Sleep mode interrupt - error_irq: Error interrupt, generated when undesired behavior or bad programming occurs in the BLE Core - rx_irq: Receipt interrupt at the end of each received packets - event_irq: End of Advertising / Scanning / Connection events interrupt - crypt_irq: Encryption / Decryption interrupt, generated either when AES and/or CCM processing is finished - sw_irq: SW triggered interrupt, generated on SW request
2	RESERVED	
3	RESERVED	
4	rfcal_irq	RF Calibration Interrupt. Generated by the DPHY.
5	RESERVED	
6	crypto_irq	Crypto interrupt. Sources: - aes_hash_irq: AES or HASH function interrupt. - ecc_irq: Elliptic Curve interrupt.
7	mrm_irq	Cache Miss Rate Monitor interrupt.
8	uart_irq	uart interrupt.
9	uart2_irq	uart2 interrupt.
10	i2c_irq	I2C interrupt.
11	i2c2_irq	I2C2 interrupt.
12	spi_irq	SPI interrupt.
13	spi2_irq	SPI2 interrupt.
14	adc_irq	ADC interrupt.
15	keybrd_irq	Keyboard scanner interrupt.
16	irgen_irq	IR generator interrupt.
17	wkup_gpio_irq	Wakeup or GPIO interrupt. Will be triggered in Deep Sleep or Hibernation modes (clock-less).
18	swtim0_irq	Timer0 interrupt.
19	swtim1_irq	Timer1 interrupt.
20	quadec_irq	Quadrature decoder interrupt.
21	usb_irq	USB controller interrupt.
22	pcm_irq	PCM interrupt.
23	src_in_irq	Sample rate converter input interrupt.

Table 19: Interrupt list

IRQ number (inherent priority)	IRQ name	Description
24	src_out_irq	Sample rate converter output interrupt.
25	vbus_irq	VBUS presence interrupt. This interrupt requires a clock to be generated. It will not be issued in clock-less power modes.
26	dma_irq	DMA interrupt.
27	rf_diag_irq	Baseband or Radio diagnostics Interrupt.
28	trng_irq	True random number generator interrupt.
29	dcdc_irq	DCDC timeout interrupt.
30	xtal16rdy_irq	XTAL16 oscillator ready interrupt. Clock is 16MHz (<50ppm) and 60/40 % duty cycle
31	RESERVED	

Interrupt priorities are programmable by the ARM Cortex M0. The lower the priority number, the higher the priority level. The priority level is stored in a byte-wide register, which is set to 0x0 at reset. Interrupts with the same priority level follow a fixed priority order using the interrupt number listed in [Table 19](#) (lower interrupt number has higher priority level).

To access the Cortex-M0 NVIC registers, CMSIS functions can be used. The input parameter IRQn of the CMSIS NVIC access functions is the IRQ number. This can be the IRQ number or (more convenient) the corresponding IRQ name listed in [Table 19](#). The corresponding interrupt handler name in the vector table for IRQ#15 is e.g. UART_Handler. For more information on the ARM Cortex M0 interrupts and the corresponding CMSIS functions, see a.o. section 4.2 Nested Vectored Interrupt Controller on pag. 4-3 in the Cortex™-M0 User Guide Reference Material.

The Watchdog interrupt is connected to the NMI input of the processor.

8 Cache Controller

The cache controller is used to accelerate the system performance of the ARM Cortex™ M0 executing from QSPI FLASH and to reduce the power consumption by reducing the access of the QSPI FLASH. The cache dynamically loads both program and data code into the cache Data RAM and executes from there.

The cache controller is controlled via the CACHE_*_REGs. The cache administration is kept in TAG memory. This memory can be invalidated by asserting the FLUSH bit in the CACHE_CTRL1_REG. The ARM Cortex™ M0 is halted during this invalidation and resumes automatically. N-way associative replacement strategy is based on the value of a pseudo random LFSR.

The cache controller supports run time configuration of cache line size and associativity. The selection of the configurations depends on the code type and application and shall be determined empirically.

For debugging purposes the Data and TAG memory can be monitored on the AHB-SYS bus (See memory map).

The cache is used for dynamic code and data caching. As an alternative for fast code executions, the data-RAM can be used for static code storage. This code must be copied from QSPI FLASH.

Features

- Cachable range up-to 32 Mbyte starting from QSPI start address, length adjustable up-to N*64kByte
- Cache size fixed 16 kB, TAG RAM size is 4 kB
- Run time configurable cache line 8, 16 or 32 bytes
- Run time configurable 1, 2 or 4 way associativity
- Built-in TAG memory invalidation (FLUSH)
- Random number (LFSR) for 2, 4 way replacement strategy
- Cache Data and TAG monitoring
- Instruction and Data caching upon read access, no write path to cache available.
- Bypass mode
 - zero wait cycle for cache hits same cache line
 - one wait cycle for cache hits when changing cache line
 - 4 + cache line size/4 cycles for cache misses
 - 0 cycle in transparent bypass mode
- Cache internal latency

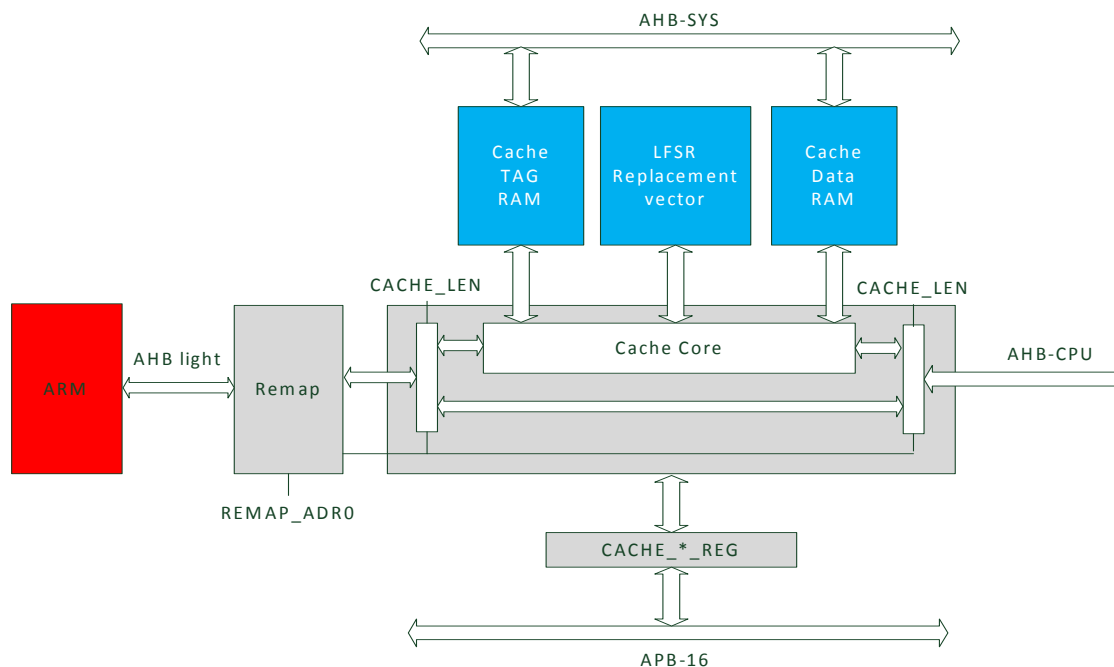

Figure 32: Cache controller block diagram

8.1 CACHABLE RANGE

The cache controller caches address range 0-0x1FFFFFFF (32 MB). If REMAP_ADRO=0x1 or 0x2, all addresses from 0 to CACHE_LEN will be cached, else the cache controller automatically asserts the

bypass mode. The bypass mode can be forced for all addresses by setting CACHERAM_MUX=0.

Note that the CACHE_LEN setting is only applicable for the QSPI FLASH remap case.

8.2 RUNTIME RECONFIGURATION

Associativity and cache line size of cache can be reconfigured at all time by writing the CACHE ASSOCCFG_REG or CACHE LNSIZECFG_REG registers. Reconfiguration is done without wait state and without flushing the cache. All the data available in the cache memory are kept except when the associativity is reduced (4-way -> 2-way and 2-way -> 1-way). In that case typically half of the data are inaccessible.

8.2.1 Cache Line reconfiguration

The dynamic configuration of the cache line size uses a physical line size of 8 bytes. When the cache line size is defined as 16 bytes or 32 bytes, 2 or 4 physical lines are involved.

Reconfiguration of the cache line occurs only when lines are replaced. Even if the cache line configuration is set to 32 bytes, cache lines of 16 bytes may remain in the cache memory as explained at the example in Table 20.

Table 20: Cache line size reconfiguration example

<p>CACHE Memory</p>	<p>CACHE Memory</p>	<p>CACHE Memory</p>	<p>Main Memory</p>
<p>Step 1: Cache line size = 16 bytes a. CPU Reads @0x00: Miss Cache Reads 16 bytes in Block 0 @0x00 b. CPU Reads @5010: Miss Cache Reads 16 bytes in Block 5 @0x10</p>	<p>Step 2: Cache line size = 32 bytes a. CPU Reads @0x00: Hit b. CPU Reads @5010: Hit c. CPU Reads @5020: Miss Cache reads 32 bytes in Block 5 @0x20</p> <p>Although the configuration is 32 bytes, the lines of 16 bytes remain in the cache. Only new lines are 32 bytes.</p>	<p>Step 3: Cache line size = 32 bytes a. CPU Reads @0x6000: Miss Cache reads 32 bytes in Block 6 @0x00</p> <p>16-byte cache lines already in the cache are replaced by the 32-byte cache line.</p>	

8.2.2 TAG memory word

The administration memory word decoding is presented in the following table:

Table 21: TAG memory layout

Bit 23	Bits 22:2	Bits 1:0
0	AHB address	00: invalid cache line 01: 8 valid bytes 10: 16 valid bytes 11: 32 valid bytes

8.2.3 Associativity reconfiguration

To enable associativity reconfiguration, the cache memory is organized into four banks.

Depending on the associativity, the four banks can operate as 4-way, or be concatenated resulting in either a 2-way or 1-way cache.

8.3 2 AND 4 WAY REPLACEMENT STRATEGY

The cache controller fills each line of the cache first starting from way0 to way3. When a line is completely full, a new way_x victim is chosen in a pseudo random way.

When a replacement is required, the cache controller reads the value generated by a pseudo-random number generator to select which way to replace.

The pseudo-random number generator is realized using a Linear Feedback Shift Register (LFSR).

8.4 CACHE RESETS

The cache controller has two reset signals connected:

- The HW_RESET. When this reset is activated, all cache logic and registers are reset to their default values, while all data in the TAG memories are cleared and all CACHE_*_REG are set to their reset values. It takes around 450 AHB cycles to clear the cache TAG memory.

If a fetch request occurs during this reset period, the request will be taken into account at the end of the reset and wait-states will be inserted.

- The SW_RESET. Upon a SW_RESET the cache state machine and TAG memories are reset, but the CACHE_*_REG are not affected and will remain as programmed.

8.5 CACHE MISS RATE MONITOR

The DA14681 incorporates a cache miss monitoring circuitry which is providing real time information on the number of cache misses within a certain amount of time. Upon reaching a programmable threshold, an interrupt is issued towards the CPU to take action. The CPU can dynamically change the cache line size, the associativity or start the PLL to decrease cache line fetch time and consequently power. It can even apply a combination of the aforementioned techniques to adjust system's parameters accordingly. This block only operates while the system is in active mode. Main features are:

- Up to 10 ms active time interval counter
- Registered amount of cache misses
- Registered amount of cache hits
- Programmable threshold of cache misses upon which, an interrupt is generated

CACHE_MRM_HITS_REG contains the amount of cache hits and CACHE_MRM_MISSES_REG the amount of misses counted within the time interval programmed at CACHE_MRM_TINT_REG in CPU clock cycles.

8.6 CACHE MISS LATENCY AND POWER

This section describes the amount of time (in clock cycles) required from a cache miss up to the point the required code/data are fetched back to the CPU and execution continues.

The cache miss latency (T_{CML}) can be split in the following intervals:

T_{CM2R} : Time from the cache miss up to request from the QSPI Controller.

T_{R2QA} : Time from request up to actual access start.

T_{RDFL} : Time for reading data from the FLASH.

T_{CLAT} : Time required to get data to the CPU (cache latency).

The final amount of clock cycles is calculated by the following equation:

$$T_{CML} = T_{CM2R} + T_{R2QA} + T_{RDFL} + T_{CLAT}$$

where T_{RDFL} depends on the amount of data requested and is provided by the following formula:

$$T_{RDFL} = T_{CMD} + T_{ADDR} + T_{DUM} + (N_{CACHELINE} * 2) + T_{PIPE}$$

For example, give a cache line configuration of 16 bytes, the amount of clock cycles required to read the

data from the FLASH is:

$$T_{RDFL} = 2 + 8 + 4 + (16 * 2) + 1 = 47 \text{ clock cycles.}$$

An overview of the cache miss latency calculation is shown in the following table:

Table 22: QSPI FLASH cache miss latency

Time Interval	Clock Cycles	Example
T_{CM2R}	3	3
T_{R2QA}	2	2
T_{RDFL}	$T_{CMD} + T_{ADDR} + T_{DUM} + (N_{CACHELINE} * 2) + T_{PIPE}$	47
T_{CLAT}	4	4
T_{CML}	for 16 bytes cache line (QPI mode)	56

The same calculation applies for the OTP cached case:

Table 23: OTP cache miss latency

Time Interval	Clock Cycles	Example
T_{CM2R}	3	3
T_{OTP_INIT}	2	2
T_{RDOTP}	$N_{CACHELINE} / 4$	4
T_{CLAT}	4	4
T_{CML}	for 16 bytes cache line	13

The T_{OTP_INIT} parameter represents the amount of cycles required for initiating the burst read of the memory.

Especially in the case of the QSPI FLASH, the amount of cache misses, the latency and the FLASH device might affect the power of the application since the FLASH has to be activated for long time intervals. However, it is measured that given a low cache miss rate, the average power is not dramatically increased. The following figure illustrates the current overhead as a result of the cache miss rate.

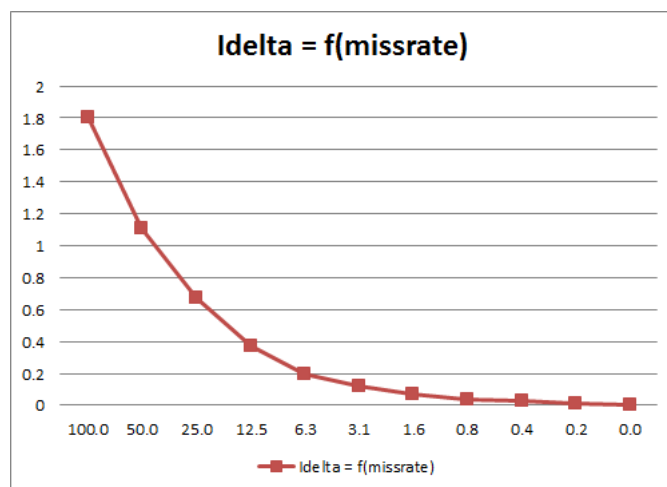

Figure 33: Current dissipation overhead due to cache miss rate (at 3V)

The average increase on an application using a FLASH device powered by the VDD1V8 pin (1.8V), with 5mA read current, is becoming visible (i.e. <1mA) if the miss rate exceeds 40%. For applications that are periodically repeating activities, the expected miss rate should be <5% hence the power overhead is minimum.

9 AMBA Bus

The DA14681 is equipped with a multi-layer AMBA bus which enables parallel data paths between different masters and slaves. The bus matrix comprises 2 main busses:

- AHB-CPU bus where the Cache, or the CPU can be masters
- AHB-DMA bus where the DMA the OTP Controller and the AES/HASH DMA can be masters

Features

- Enables data transfers from peripherals to memory while executing code from OTP or external QSPI FLASH
- Provides programmable master priority on AHB-CPU bus
- Provides programmable ICM priority for the connected Slaves
- Enables AHB access of the CPU at the cache RAM if no cache functionality is required

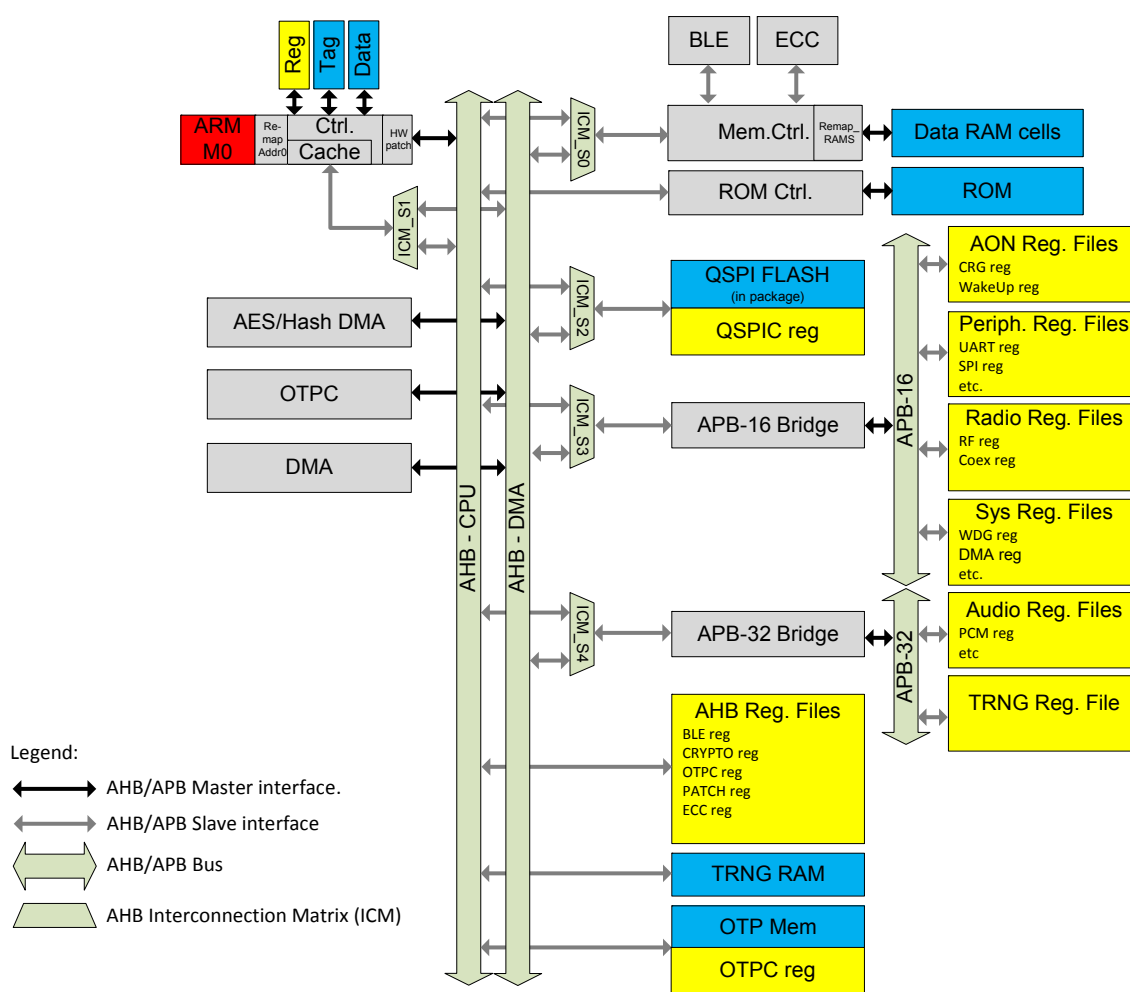

Figure 34: AMBA Bus architecture

There are six slaves which are sitting behind interconnection multiplexers (ICMs) namely:

- Memory controller which controls the DataRAM and the ROM cells
- QSPI FLASH memory controller and memory
- 16-bit APB peripheral registers
- AHB register files for the rest of the resources as well as the TRNG RAM
- 32-bit APB peripheral registers
- Cache controller which enables AHB access of the CPU at the cache RAM to be used as an extension of the DataRAM in the case of mirrored mode.

In the latter case, the ICM_S0 provides a direct access of the CPU at the cache RAM cell. The Cache RAM cell is always mapped at address 0x20010000. The TAG RAM is not used during this mode of operation.

The priority on the AHB-DMA busses regarding the master arbitration is programmable. The following table depicts the default priority scheme (1=Highest Priority):

Table 24: AHB-DMA master default priorities

Priority	Master
1	OTP Controller DMA
2	AES/HASH DMA
3	Generic DMA

10 Memory Controller

The Memory controller is responsible for the interface of the memory cells with the masters of the system requesting for access. It comprises an arbiter which allows for a configurable priority level between the 3 main masters of the RAM. The memory controller also allows for the actual physical sequence of the RAM cells in a continuous memory space enabling activation of just the required amount of DataRAM thus saving on power.

Features

- Five different RAM cells with retention capability (one 8 kB, one 24 kB and three 32 kB)
- Full flexibility of re-arranging the first 3 RAM cells in a continuous RAM space starting at 0x7FC0000
- Arbitration between the AHB masters (CPU or DMAs) the BLE core and the ECC
- Retainable configuration of the RAM cells sequence.

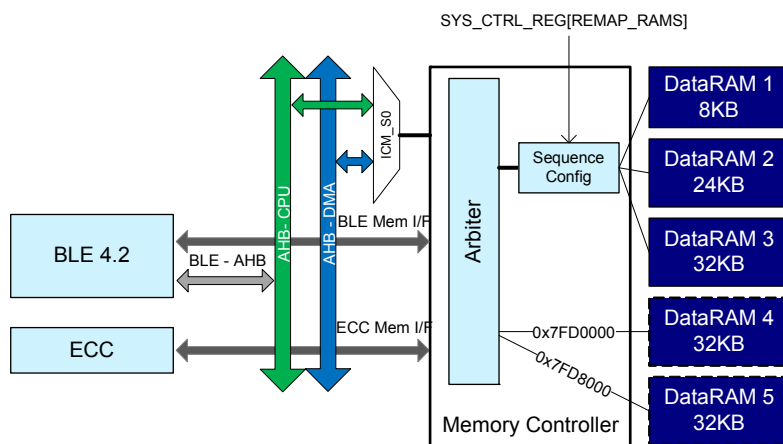

Figure 35: Memory Controller Block Diagram and environment

The Shuffle_RAM word in the OTP header encodes the sequence of the RAM cells. This is described in the following table:

Table 25: DataRAM cells sequence

Value	Cell	Address	Size (kB)
0x0	DataRAM1	0x7FC0000	8
	DataRAM2	0x7FC2000	24
	DataRAM3	0x7FC8000	32
0x1	DataRAM2	0x7FC0000	24
	DataRAM1	0x7FC6000	8
	DataRAM3	0x7FC8000	32
0x2	DataRAM3	0x7FC0000	32
	DataRAM1	0x7FC8000	8
	DataRAM2	0x7FCA000	24
0x3	DataRAM3	0x7FC0000	32
	DataRAM2	0x7FC8000	24
	DataRAM1	0x7FCE000	8

Selecting the appropriate shuffle value, the minimum required memory space can be left retained during sleep modes hence reducing the sleep power dissipation.

The Memory Controller contains an Arbiter which con-

nects to the following busses:

- ICM which multiplexes the CPU or the DMA access. This interface is capable of operating at maximum 96MHz
- BLE Memory I/F: this is a memory interface from the BLE 4.2 Core directly accessing the RAM used as exchange memory (TX/RX descriptors etc.). This interface is always operating at 16MHz.
- ECC Memory I/F: this is a memory interface from the Elliptic Curve Crypto block directly accessing the RAM used as crypto shared memory. This interface is capable of operating at maximum 96MHz.

The Arbiter implements the priority scheme as depicted in the following figure:

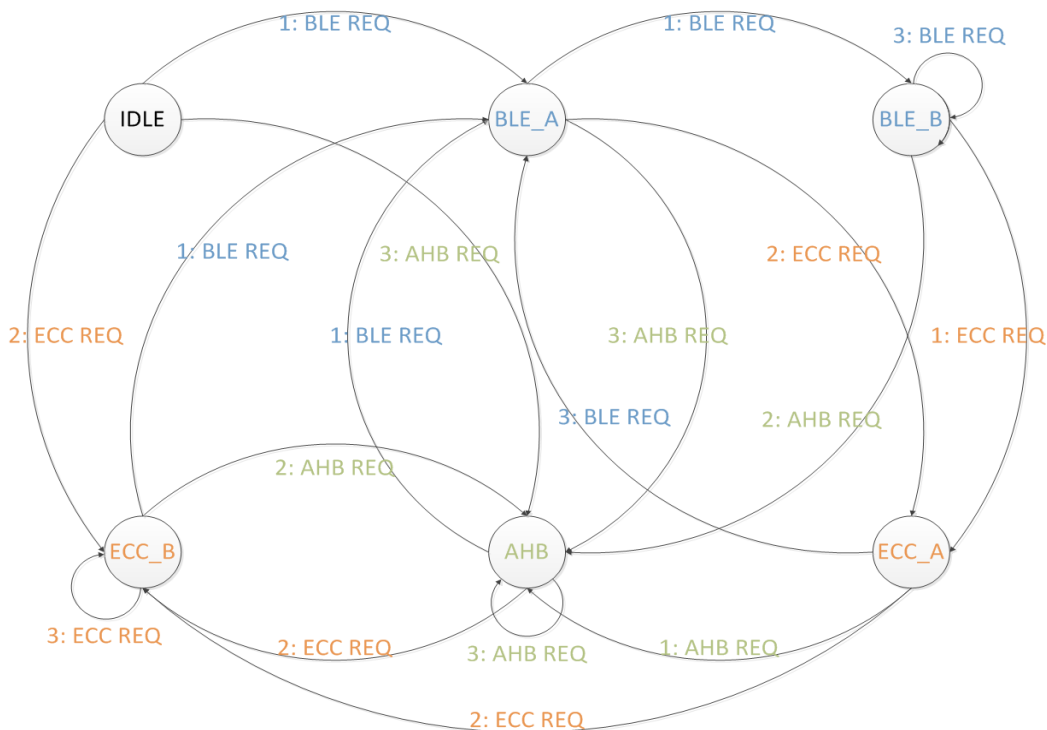

Figure 36: Memory controller’s arbitration scheme

The overall RAM size can reach up to 144 kB using all available RAM cells of the system (except for the TAG RAM cell). Bypassing the cache controller adds the Cache RAM on the overall RAM budget at the end of the available memory space (0x7FC8000).

The Sequence Configuration block defines the sequence of the memory cells in a continuous memory space according to the REMAP_RAM vector. All of the cells can be retained at will. Shuffling of the memory cells will give the best configuration in terms of exchange (retainable) memory, code segment and data segment.

The Memory Controller operates at the same clock as the CPU.

11 OTP Controller

The OTP controller realizes all functions of the OTP macro cell in an automated and transparent way. The controller facilitates all data transfers (reading and programming), while implementing the required OTP test modes in hardware. It integrates Error Correcting Code (ECC) hardware for correcting single bit and detecting double bit errors and Built-in Self Repair (BISR) protecting the memory cell space. An embedded DMA engine enables mirroring of the OTP contents into the DataRAM via the AHB-DMA bus.

Features

- Implements all timing constraints for any access to the physical memory cells.
- 64-bits read in a single clock cycle from the OTP cell
- Transparent random address access to the OTP memory cells via the AHB slave memory interface.
- Embedded DMA engine for fast mirroring of the OTP contents into the System RAM.
- Embedded DMA supports reading in bursts of 8 32-bit words
- Built-In Self Repair (BISR) mechanism for programming and reading
- Up to 48 MHz operation (96 MHz is not supported)
- Hardwired handshaking with the PMU to realize the mirroring procedure
- Automatic single Error Code Correction (ECC) and double error detection

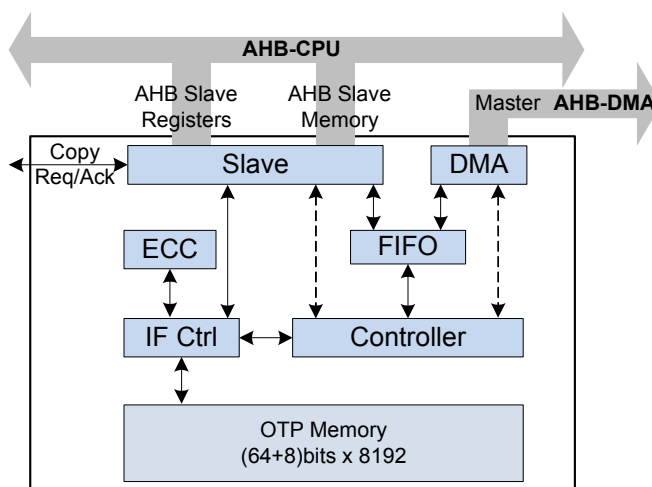

Figure 37: OTP Controller block diagram

11.1 OPERATING MODES

There are two different functional modes of operation for reading and programming respectively: manual (MREAD, MPROG) and automatic (AREAD, APROG). The OTP operating mode is programmable at `OTPC_MODE_REG[OTPC_MODE_MODE]`.

The **MREAD** mode enables the use of the memory slave interface. By activating this mode the contents of the macro cell are transparently mapped onto the specific AHB slave address space. The controller runs the SECDED algorithm on the fly to correct single bit errors and notify for dual bit errors by means of the status register. This mode can be used for execution of software in place (XIP).

The **AREAD** mode provides the ability for reading data from the macro cell in bursts, without the use of the slave interface. This mode is used for copying large data blocks from the macro cell, as in the case of the OTP mirroring into the DataRAM. As in the MREAD mode, SECDED is also applied on every burst. However, transfer will occur even if an error has been identified in the status register.

tified in the status register.

The **MPROG** mode provides the functionality for programming a 64 bit word. The controller expands the 64 bit word by calculating and appending an 8-bit checksum, implementing SECDED (Single Error Correction Double Error Detection). In this way a complete 72 bits word is constructed, which is stored at a selected OTP position.

Programming is performed in a single step. In the case that one or more bits have failed to be programmed correctly, software should trigger re-programming.

The 64 bit data word as well as the address are defined through configuration registers. The controller applies the corresponding control sequence for the programming and the result of the verification step is indicated in a status register.

The **APROG** mode gives the ability for programming large data blocks into the macro cell. The programming is an automated procedure, during which it is only necessary to feed the controller with the required data.

Data blocks can be fetched in two ways:

- Via the AHB master interface, i.e. the DMA.
- Via the AHB slave registers.

In the latter case, data are pumped into the OTP controller through a register, which acts as a port providing access to a FIFO. The controller expands each 64 bit word by calculating and adding automatically an 8-bit checksum, in order to provide SECDED functionality.

11.2 AHB MASTER INTERFACE

The AHB master interface is controlled by a DMA engine with an internal FIFO of 8 32-bit words. The DMA engine supports AHB reads and writes. The AHB address where memory access should begin, is programmed into the DMA engine at OTPC_AHBADR_REG[OTPC_AHBADR]. The number of 32-bit words (minus 1) of a transfer must be specified in OTPC_NWORDS_REG[OTP_NWORDS].

The DMA engine internally supports the following burst types:

- Eight words incremental burst (INCR8)
- Four words incremental burst (INCR4)
- Unspecified incremental burst (INCR) with length different than 1, 4 or 8
- Single word access (SINGLE)

11.3 AHB SLAVE INTERFACES

The slave block combines two AHB slave interfaces. One for the registers and another for the contents of the OTP memory. The first AHB slave is read/write while the second is read only. The controller should be configured into MREAD mode prior to any access on the slave interfaces. If this is not the case, an ERROR response on the bus will occur. The same ERROR can also be triggered upon a SECDED detection.

11.4 ERROR CORRECTING CODE (ECC)

The error correcting code is based on the Hamming code, for a single bit error correction. The functionality of the Hamming code has been enhanced with the addition of a parity bit. The presence of the parity bit enables the detection of a double bit error.

The redundancy that is provided by the use of the two algorithms (Hamming and parity generation) is stored together with the actual data at each OTP position, consisting of a 72 bits word. The exact layout of the OTP word is presented in the following figure:

Bit 71	Bit 70-64	Bit 63-0
Parity	Check Bits	Payload Data

Figure 38: OTP word layout

11.5 BUILD-IN SELF REPAIR (BISR)

The repair mechanism is available only during programming (APROG mode only) or reading (Both AREAD and MREAD). Only the main memory array is protected (there is no repair mechanism for the spare rows). It is also not available during blank check.

In the case of programming the OTP, the controller initially tries to write to the normal memory array. There are two cases depending on the result of the programming:

1. The programming in the main memory array succeeds (with one or zero errors). The programming ends normally.
2. The programming of the main memory array fails. If there are already 8 repair records occupied, programming fails and the device is discarded. Otherwise, a new repair record is added. The controller writes the new repair record in the spare area. In the case of a failure (two or more errors) the device is discarded. Otherwise the programming ends successfully.

Reading from the OTP cell requires the corresponding registers of the OTP controller to be loaded with the repair information. When a read action is requested, the OTP controller performs a search in the repair records.

If the address, of the read requested, is found in one of the repair records, the data are not retrieved from the normal memory array of the OTP, but from the repair records. The ECC is, in this case, bypassed.

If there is no match to a repair record, data are retrieved from the normal memory array. ECC is then activated.

12 Quad SPI Controller

The Quad SPI Controller (QSPIC) provides a low pin count interface to FLASH memory devices. The QSPIC supports the standard Serial Peripheral Interface (SPI) and a high performance Dual/Quad SPI Interface.

The QSPIC gives the ability to read data from a quad FLASH memory, transparently through the SPI bus. This Execute In Place (XIP) feature combined with the CPU cache, provides comparable performance to executing code from standard parallel FLASH. In this case the QSPIC generates all the control signals for the SPI bus that are needed to read data from the serial FLASH memory. Additionally, software can easily control the serial FLASH memory via a memory mapped register file which is contained in the QSPIC. All instructions supported by the FLASH memory, can be programmed using the above register file.

A special feature of the QSPIC enables for automated re-initialization of the FLASH device right after power up, without the CPU being involved, thus reducing initialization time and consequently power dissipation. An small initialization memory of 16 32-bit retainable words, contains an encoded sequence of commands which are shifted in to the FLASH memory right after waking up from power down modes.

Features

- SPI Modes:
 - Single: Data transfer via two unidirectional pins.
 - Dual: Data transfer via two bidirectional pins.
 - Quad: Data transfer via four bidirectional pins.
- Auto Mode: up-to 32 Mbyte transparent Code access for XIP (Execute In Place) and Data access with 3-byte and 4-byte addressing modes.
- Manual Mode: Direct register access using the QSPIC register file.
- Up-to 96 MHz QSPI clock. Clock modes 0 and 3. Master mode only.
- Vendor independent Instruction Sequencer.
- In Auto Mode the FLASH control signals are fully programmable.
- Support for single access and high performance burst mode in combination with the cache controller (in Auto Mode).
- Use of a special read instruction in the case of a specific (programmable) wrapping burst access.
- Erase suspend/resume to Support for Code and Data storage
- Hardware initialization state machine based on uCode commands.

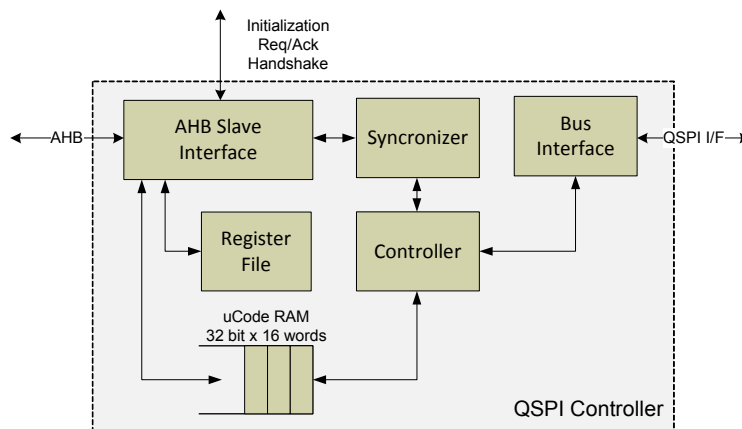

Figure 39: Quad SPI Controller architecture

12.1 ARCHITECTURE

The AHB slave block implements two AHB Slave interfaces which enable access to the register file and the uCode memory. The Controller implements all protocol related to the functionality of the FLASH memory. It contains a finite state machine (FSM) that generates all necessary signalling to the QSPI bus and realizes all features of the Auto mode operation. Moreover, it manages all data transfers between the two interfaces (the AHB and the QSPI).

The Bus Interface block controls the QSPI signals at the lowest level while the Synchronizer implements

"stretching" or "shortening" of the signals that cross the two clock domains.

The uCode memory is 16 words x 32 bits and contains the microcode for the initialization of the FLASH memory even before the CPU has been waken up. The signalling between the FIFO and the PMU is done through the request/acknowledge signals.

12.1.1 Interface

The Quad SPI Controller uses the following signals:

- QSPI_SCK: output serial clock

- QSPI_CS: Active Low output Chip select.
- QSPI_IO0:
 - DO (output) in Single SPI mode
 - IO0 (bidirectional) in Dual/Quad SPI mode.
- QSPI_IO1:
 - DI (input) in Standard SPI mode
 - IO1 (bidirectional) in Dual/Quad SPI mode.
- QSPI_IO2:
 - General purpose (output) (e.g. WPn Write Protect) in Standard SPI mode
 - IO2 (bidirectional) in Quad SPI mode.
- QSPI_IO3:
 - General purpose (output) (e.g. HOLDn) in Single SPI mode
 - IO3 (bidirectional) at Quad SPI mode.
- The output drive of the pads is programmable via register bits QSPI_GP_REG[QSPI_PADS_DRV] and the slew via QSPI_GP_REG[QSPI_PADS_SLEW]
- The outputs pads have push-pull configuration and are supplied from VDDIO.

The Quad SPI Controller (QSPIC) drives all data pins constantly except for the case when a read is performed. The time for changing the direction of the pads is at least $1.5 \times \text{QSPI_CLK}$ (QSPI_CLK being the clock that the FLASH operates on). In this way, data lines are always terminated thus reducing unnecessary power consumption.

The default state of the QSPI_IOx pins is 1. This state is applied at the pins as soon as the QSPIC clock is enabled even if no access to the FLASH has yet been triggered. The value of the pins might be changed by programming the respective registers (QSPIC_IOx_DAT, QSPIC_IOx_OEN). This value will be valid only after the QSPI_CS is pulled low, i.e. an access to the FLASH occurs.

12.1.2 Initialization FSM

Since the QSPIC is used in an ultra low power SoC, it is very possible that the FLASH memory will be either totally powered off, or set into deep power down mode when the system goes to any of the sleep modes. However, upon power-up or wake-up, the FLASH device requires a number of commands to get at a state where the CPU can actually execute code from. This initialization should be done prior to the CPU wakeup. The QSPIC contains a hardware state machine which decodes a number of commands in a 16 32-bit word retainable FIFO and initializes the FLASH automatically even before the CPU is waken up.

The command FIFO will be initialized upon cold boot of the system by the CPU with the commands residing in the OTP header. The start address of the RAM to be programmed with the uCode is 0x0C000040. The command encoding is presented in the following table:

Table 26: Initialization Command Encoding

Bit	Name	Description
Byte 0		
7:3	CMD_NBYTES	The number of payload bytes to be sent
2:1	CMD_TX_MD	QSPI bus mode when transmitting the command: 0x0: single SPI 0x1: Dual SPI 0x2: Quad SPI 0x3: Reserved
0	CMD_VALID	1: the command record is valid 0: the command record is not valid
Byte 1		
7:0	CMD_WT_CN T_LS	Number of clock cycles to wait after applying the command (least significant byte)
Byte 2		
7:0	CMD_WT_CN T_MS	Number of clock cycles to wait after applying the command (most significant byte)
Byte 3 to (CMD_NBYTES+2)		
		The actual data bytes to be sent within a CS envelope

The first byte (LSByte) in the word of the FIFO contains the flag of the command being valid or not, the bus mode of operation and the number of bytes contained in the payload to be sent.

The second and third byte define the amount of clock cycles that the QSPIC has to wait after applying the command. The clock to be used is the RC16 (~16 MHz), which results to a maximum of 4 ms waiting time. If more time is required by the FLASH, then multiple identical commands might be issued.

Example:

Considering 0xAB to be the opcode for releasing the FLASH from deep power down mode, the FIFO would be initialized with the following sequence:

Table 27: FLASH Initialization uCode example

Byte	Value	Description
0	0x11	Valid command record, single SPI mode, 2 bytes of payload
1	0x01	1 clock cycle wait after command is sent
2	0x00	
3	0xAB	Actual FLASH command opcode

12.1.3 SPI modes

The Quad SPI Controller (QSPIC) supports the following SPI standards:

- Single: Data transfer via two unidirectional pins.

Note 2: The QSPIC supports communication to any single/dual or Quad SPI FLASH memory. Contrary to the Standard SPI interface, the supported Single SPI interface does **not** support the bus modes 1 and 2, does **not** support full-duplex communications and does **not** support any SPI slave mode.

- Dual: Data transfer via two bidirectional pins.
- Quad: Data transfer via four bidirectional pins.

12.1.4 Access modes

The access to a serial FLASH connected to the QSPI can be done in two modes:

- Auto mode
- Manual mode

These modes are **mutually exclusive**. The serial FLASH can be controlled only in one of the two modes. The registers which control the mode of operation can be used at any mode.

In auto mode, 3-bytes and 4-bytes addressing modes are supported. With QSPIC_CTRLMODE_REG [QSPIC_USE_32BA]=0, up to 16 MBytes QSPI (3-bytes addressing) can be accessed. If QSPIC_USE_32BA=1, the 4-bytes addressing is enabled for accessing up to 32 Mbyte QSPI FLASH.

Auto mode

In auto mode a read access from the serial FLASH memory is fully transparent to the CPU. A read access at the interface is translated by the QSPIC into the respective SPI bus control commands needed for the FLASH memory access.

When the Auto Mode is disabled, any access (reading or writing) will be ignored. When the Auto Mode is enabled, only read access is supported. A write access causes hard fault. A read access can be single access, incremental burst or wrapping burst. Wrapping burst is supported even when the FLASH device doesn't support any special instruction for wrapping burst. A special read instruction can be used in the case of a specific (programmable) wrapping burst access. When a FLASH supports a special instruction for wrapping burst access, this feature reduces access time (less wait states). For maximizing the utilization of the bus and minimizing the number of wait states, it is recommended to use burst accesses. However, non-sequential random accesses are supported with the cost of more wait states.

Manual Mode

In manual mode the FLASH memory is controlled via a register file. All instructions that are supported by a FLASH memory can be programmed using the register file. Moreover, the mode of interface (SPI, Dual SPI, Quad SPI) and the mode of operation (Auto or Manual

Mode) can be configured via this register file. The register file supports the following data sizes for reading and writing accesses: 8-bits, 16-bits and 32 bits.

12.1.5 Endianness

The QSPIC operates in little-endian mode. For 32-bit or 16 bit access (for read and write operations) to a serial FLASH memory, the least-significant byte comes first. For 32-bit access the byte ordering is: data [7:0], data [15:8], data [23:16], data [31:24] while for 16-bit access the byte ordering is: data [7:0], data [15:8].

12.1.6 Erase Suspend/Resume

The QSPI FLASH can be used for Data Storage, combining the EEPROM functionality + Program storage in one single device.

For this purpose the QSPI ERASE/SUSPEND ERASE RESUME commands are automatically executed as shown in [Figure 40](#)

To store data in QSPI FLASH, execution from QSPI must temporary be stopped by running directly from RAM or from a cached program part. The sector designated for storage must be erased first in case it contained data already.

The process is implemented in a HW FSM and consists of the following steps:

1. The controller is in Auto mode and read requests are served. The Erase procedure is initiated by setting QSPIC_ERASE_EN=1. The address of the sector that will be erased, is defined at QSPIC_ERS_ADDR. When an Erase procedure is requested, the controller jumps to state 2.
2. Read requests are still served. As soon as the Read requests stop (also possible due to late bus master change, e.g DMA) and there is no any new Read request for a number of AHB clock cycles equal to QSPIC_ERSRES_HLD, then QSPIC_WEN_INST and QSPIC_ERS_INST instructions are sent to the FLASH. The QSPIC_RESSUS_DLY counter is started and the controller jumps to state 3.
3. Erasing is in progress in FLASH and the QSPI controller waits until one of the following events occur:
 - A status check request. This request can be forced by writing QSPIC_CHCKERASE_REG. The QSPI controller will then read the status of the FLASH memory and check if erasing has finished. Reading of the status is delayed by QSPIC_RESSTS_DLY cycles or by QSPIC_RESSUS_DLY cycles. The first is based on the clock of the SPI bus, while the latter on an internal 222 KHz clock. The selection between the two delays is configured by QSPIC_STSDLY_SEL bit. If erasing has finished, the QSPI controller returns to the normal operation (state 1) and sets QSPIC_ERASE_EN= 0, otherwise it remains at

- state 3.
- A FLASH read data request on the AHB bus. The QSPI controller reads the status of the FLASH memory and checks if erasing is done. The reading of the status will be delayed again as in the previous case by QSPIC_RESSTS_DLY or QSPIC_RESSUS_DLY. If erasing has ended, the controller returns to normal operation (state 1) and sets QSPIC_ERASE_EN=0. The read request will be served as soon as the controller reaches state 1. If erasing has not ended, the controller proceeds to state 4.
 - 4. The QSPIC_SUS_INST is sent as soon as the QSPIC_RESSUS_DLY/QSPIC_RESSTS_DLY counter is 0. The controller jumps to state 5.
 - 5. The controller polls the FLASH status register,

- until the FLASH device becomes ready (erasing is suspended). The controller will then proceed to state 6.
- 6. The erasing process in the FLASH is now suspended and the controller may read the FLASH. The requested data are retrieved from the FLASH device. If the reading on the AHB stops (e.g Cache hit) and there is no new Read requests for a number of AHB clock cycles equal to QSPIC_ERSRES_HLD, the controller goes to state 7.
- 7. The QSPIC_RES_INST instruction is applied and the controller jumps back to state 3. Also, the QSPIC_RESSUS_DLY counter is started. As result, the erase procedure is resumed.

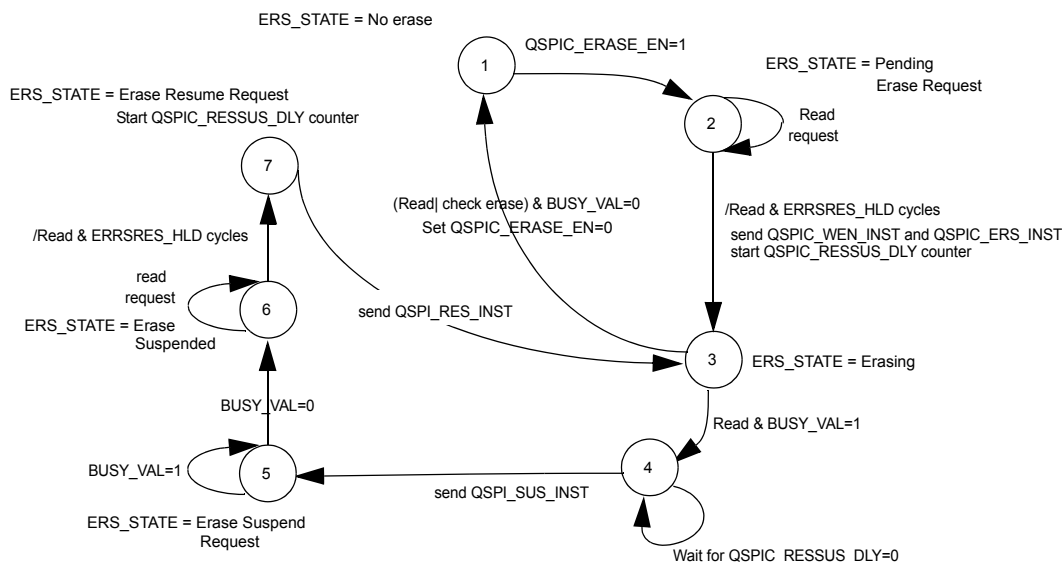

Figure 40: Erase Suspend/Resume in Auto mode

Refer to AN-D-185 for further Application information

Note that, QSPI_RESSTS_DLY counts QSPI_CLK cycles, so before changing the QSPI_CLK, make sure that QSPI_RESSTS_DLY is set large enough to meet the timing parameter requirements of the FLASH device used.

12.1.7 QSPI FLASH Programming

Programming the sectors is done in manual mode with polling status bit in the QSPI FLASH. During programming, the ARM Cortex™ M0 **must** run from cache without cache misses or from RAM. **Furthermore interrupts should be disabled while programming the FLASH.**

Byte programming is relatively short, so a polling loop could be acceptable to meet system latency require-

ments. Refer to vendor's datasheet.

12.2 PROGRAMMING

12.2.1 Auto Mode

Chip selection

In auto mode the QSPI executes from address 0. See ARM chapter remap function

Burst control phases

In the case of Auto Mode of operation the QSPIC generates a sequence of control signals in SPI BUS. This sequence of control signals is analysed to the following **phases**: instruction phase, address phase, extra byte phase, dummy clocks phase and read data phase. These phases can be programmed via registers

- QSPIC_BURSTCMDA_REG

- QSPIC_BURSTCMDDB_REG.

Bits QSPIC_INST are used to set the selected instruction for the cases of incremental burst or single read access. If bit QSPIC_WRAP_MD is equal to 1, bit QSPIC_INST_WB can be used to set the used instruction for the case of a wrapping burst read access of length and size described by the bits QSPIC_WRAP_LEN and QSPIC_WRAP_SIZE respectively. In all other cases the QSPIC_INST is the selected instruction.

If the **instruction** must be transmitted only in the first access after the selection of Auto Mode, then the QSPIC_INST_MD must be equal to 1.

To enable the **extra byte phase** set QSPIC_EXT_BYTE_EN=1 register. The transmitted byte during the extra byte phase is specified by the QSPIC_EXT_BYTE register. To disable (hi-Z) the output pads during the transmission of bits [3:0] of extra byte, set QSPIC_EXT_HF_DS =1.

The number of **dummy bytes** during the dummy clocks phase is specified by register QSPIC_DMY_NUM and enabled by QSPIC_DMY_FORCE.

The SPI BUS mode during each phase can be set with register bits:

- QSPIC_INST_TX_MD for the instruction phase
- QSPIC_ADR_TX_MD for the address phase
- QSPIC_EXT_TX_MD for the extra byte phase
- QSPIC_DMY_TX_MD for the dummy byte phase
- QSPIC_DAT_RX_MD for the read data phase.

If the Quad SPI mode is selected in any of the above phases, write 0 to the QSPIC_IO3_OEN and QSPIC_IO2_OEN.

If the FLASH Memory needs to be accessed with any instruction but the read instruction, then the **Manual Mode** must be used.

The final step to enable the use of Auto Mode of operation is to set the QSPIC_AUTO_MD equal to 1.

12.2.2 Manual Mode

For the Manual Mode QSPIC_AUTO_MD must be equal to zero.

Manual operation of the bus signals is done via QSPIC_CTRLBUS_REG:

- The start/end of an access can be controlled using bits QSPIC_EN_CS and QSPIC_DIS_CS respectively.
- The SPI bus mode of operation can be configured with bits QSPIC_SET_SINGLE, QSPIC_SET_DUAL and QSPIC_SET_QUAD.

Writing to QSPIC_WRITEDATA register is generating a data transfer from the QSPIC to the SPI bus.

A read access at QSPIC_READDATA register is gener-

ating a data transfer from the SPI bus.

Writing to QSPIC_DUMMYDATA register is generating a number of dummy clock pulses to the SPI bus.

When access to the SPI bus via QSPIC_WRITEDATA, QSPIC_READDATA and QSPIC_DUMMYDATA is very slow, most probably the delay in accessing the internal AHB is large. In this case, set the QSPIC_HRDY_MD register equal to 1 to increase priority when accessing the required registers. All masters of the SoC can access the AHB bus interface without waiting of the SPI Bus access completion. Polling of the QSPIC_BUSY register must be done to check the end of the activity at the SPI bus, before issuing any more accesses. If a read transaction is finished, QSPIC_RECVDATA contains the received data.

The state and the value of the QSPI_IO[3:2] is specified with the following registers bits:

- QSPIC_IO3_OEN, QSPIC_IO3_DAT (Used for the WPn, Write Protect function).
- QSPIC_IO2_OEN, QSPIC_IO2_DAT respectively (Used for the HOLDn function).

12.2.3 Clock selection

The SPI clock mode as set with bit QSPIC_CLK_MD

The supported modes for the generated SPI clock is:

- 0 = Mode 0. The QSPI_SCK is low, when the bus is idle (QSPI_CS is high).
- 1= Mode 3. The QSPI_SCK is high, when the bus is idle (QSPI_CS is high).

The QSPI_CLK frequency has a programmable divider CLK_AMBA_REG[QSPI_DIV] which divides either XTAL16 or PLL by 1,2,4,8.

This results in frequency ranges:

- In XTAL16 mode: between 2 MHz and 16 MHz
- In PLL mode: between 12 MHz and 96 MHz.

The QSPI_CLK can be faster or slower than HCLK.

12.2.4 Received data

The standard method to sample received data is by using the positive edge of the QSPI_SCK. However, when the output delay of the FLASH memory is high, a timing problem on the read path is very likely. For this reason the QSPIC can be programmed to sample the received data with the negative edge of the QSPI_SCK. This is configured with the QSPIC_RXD_NEG register.

Furthermore the receive data can be pipelined by setting QSPI_RPIPE_EN=1 and the sampling clock can be delayed using QSPI_PCLK_MD. This enables sampling the received data later than the actual clock edge allows.

12.3 TIMING

This section contains timing diagrams for input and output signals

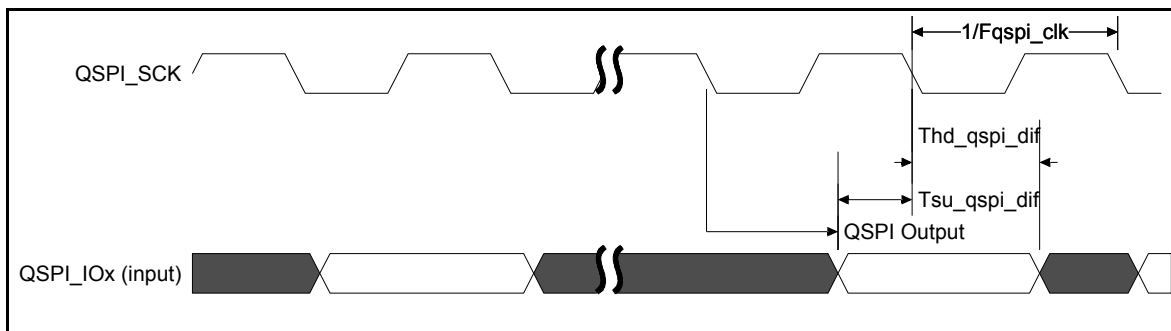

Figure 41: QSPI Input Timing

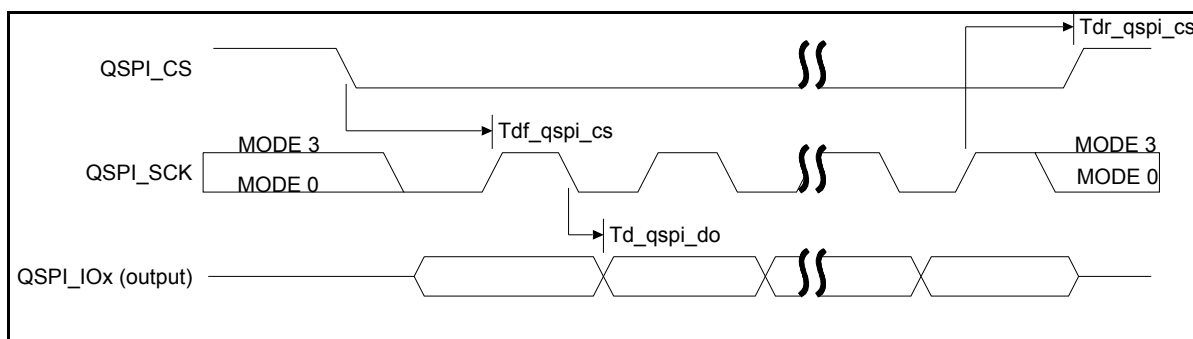

Figure 42: QSPI output Timing

Table 28: QSPI bus timing (VDDIO = 1.8V, Cloud=15 pF)

PARAMETER	DESCRIPTION	CONDITIONS	MIN	TYP	MAX	UNITS
Fqspi_sck	QSPI_SCK frequency				96	MHz
Td_qspi_do	Delay QSPI_SCK to QSPI_IOx		-1.4		3	ns
Tdr_qspi_cs	Delay QSPI_SCK to QSPI_CS	Tqspi_sck=1/Fqspi_sck	Tqspi_sck -2.5		Tqspi_sck +2.0	ns
Tdf_qspi_cs	Delay QSPI_CS to QSPI_SCK	Tqspi_sck=1/Fqspi_sck	Tqspi_sck -2.5		Tqspi_sck +3.5	ns
Tsu_qspi_dif	Setup time QSPI_IO to QSPI_SCK falling edge with variable readpipe sample clock delay QSPI_RPIPE_EN=1	QSPIC_PCLK_MD=6	2.6			ns
Thd_qspi_dif	Hold time QSPI_SCK falling edge to QSPI_IO with variable readpipe sample clock delay QSPI_RPIPE_EN=1	QSPIC_PCLK_MD=6	-0.3			ns

Note 3: Total Delay QSPI FLASH output + PCB delay + Tsux_qspi_dif < 1/Fqspi_sck.
 E.g Winbond output + PCB delay = 6ns, -> Tsux_qspi_dif < 1/96MHz - 7 = 3.41 -> QSPI_PCLK_MD= 6, QSPI_RPIPE_EN=1 is recommended value for all QSPI_SCK frequencies and shall be set before the maximum frequency is applied

13 DMA Controller

The DMA controller has eight Direct Memory Access (DMA) channels for fast data transfers from/to SPI, UART, I2C, USB, PDM and ECC to/from any on-chip RAM.

The DMA controller off-loads the ARM interrupt rate if an interrupts is given after a number of transfers.

More peripherals DMA requests are multiplexed on the 8 available channels, to increase utilization of the DMA service throughout the system.

Features

- 8 channels with optional peripheral trigger
- Full 32 bit source and destination pointers.
- Flexible interrupt generation.
- Programmable length
- Flexible peripheral request per channel
- Option to initialize memory

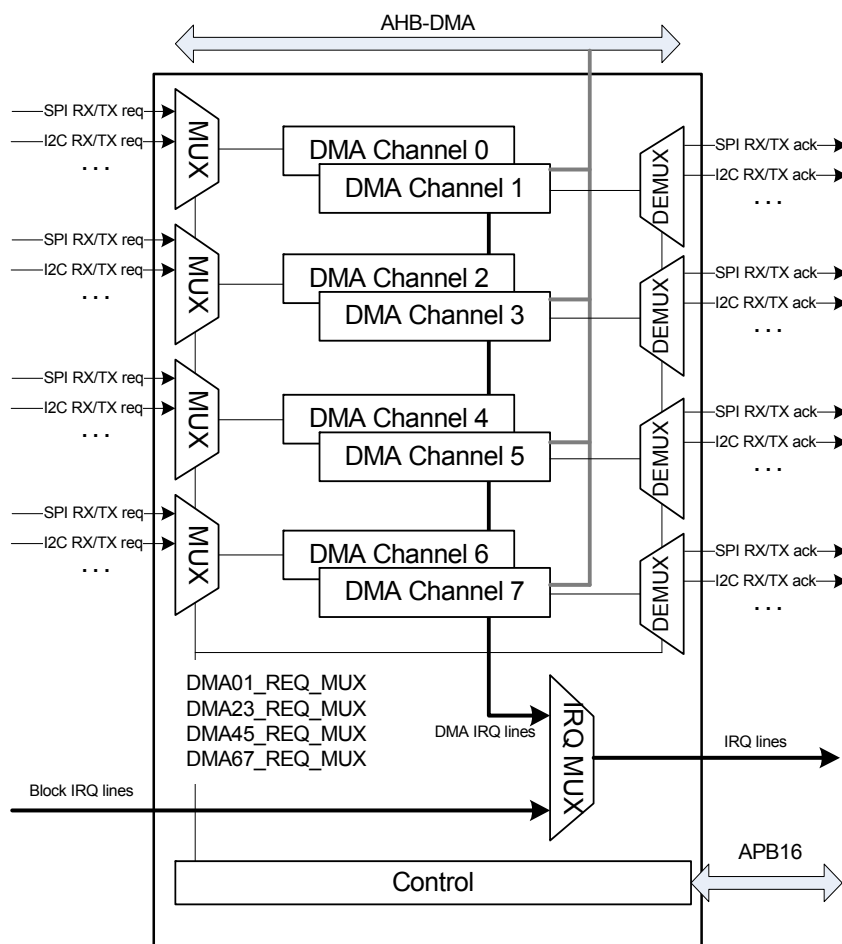

Figure 43: DMA controller block diagram

13.1 DMA PERIPHERALS

There is a list of peripherals that can request for a DMA service. The list is presented in the following table:

Table 29: DMA served peripherals

Name	Direction
SPI	RX
SPI	TX
SPI2	RX
SPI2	TX
UART	RX
UART	TX
UART2	RX
UART2	TX
I2C	RX
I2C	TX
I2C2	RX
I2C2	TX
USB_FS	RX
USB_FS	TX
ADC	Read
PCM	RX
PCM	TX
SRC	RX
SRC	TX

ECC can also be served by the DMA but will not be requesting for data as other peripherals.

Please note that for the TX DMA transfers to UART/UART2 and I2C/I2C2, it is required that $pclk = hclk$ (i.e. $CLK_AMBA_REG[PCLK_DIV]=0x0$) and that the TX FIFO threshold level is not set to the highest value available where applicable.

13.2 INPUT/OUTPUT MULTIPLEXER

The multiplexing of peripheral requests is controlled by `DMA_REQ_MUX_REG`. Thus, if `DMA_REQ_MUX_REG[DMAxy_SEL]` is set to a certain (non-reserved) value, the TX/RX request from the corresponding peripheral will be routed to DMA channels y (TX request) and x (RX request) respectively.

Similarly, an acknowledging de-multiplexing mechanism is applied.

However, when two or more bit-fields (peripheral selectors) of `DMA_REQ_MUX_REG` have the same value, the lesser significant selector will be given priority (see also the register's description).

13.3 DMA CHANNEL OPERATION

A DMA channel is switched on with bit `DMA_ON`. This bit is automatically reset if the dma transfer is finished. The DMA channels can either be triggered by software or by a peripheral DMA request. If `DREQ_MODE` is 0, then a DMA channel is immediately triggered. If `DREQ_MODE` is 1 the DMA channel can be triggered by a hardware interrupt.

If DMA starts, data is transferred from address `DMAx_A_START_REG` to address `DMAx_B_START_REG` for a length of `DMAx_LEN_REG`, which can be 8, 16 or 32 bits wide. The address increment is implemented using a 16-bit index counter (`DMAx_IDX_REG`), initialized to 0 when the transfer starts. This register is increased by 1 at the end of each DMA cycle and is then compared to `DMAx_LEN_REG`, to determine the transfer's completion. It is then automatically reset to 0 again.

Based on this register, the DMA engine forms the source/destination address at each DMA cycle, by adding it to `DMA_A/B_START_ADDR`, after shifting it by 1 (when `DMAx_CTRL_REG[BW]=0x1`) or by 2 (when `DMAx_CTRL_REG[BW]=0x2`).

It also noted that, `AINC/BINC` must be set to '0' for source/destination register access.

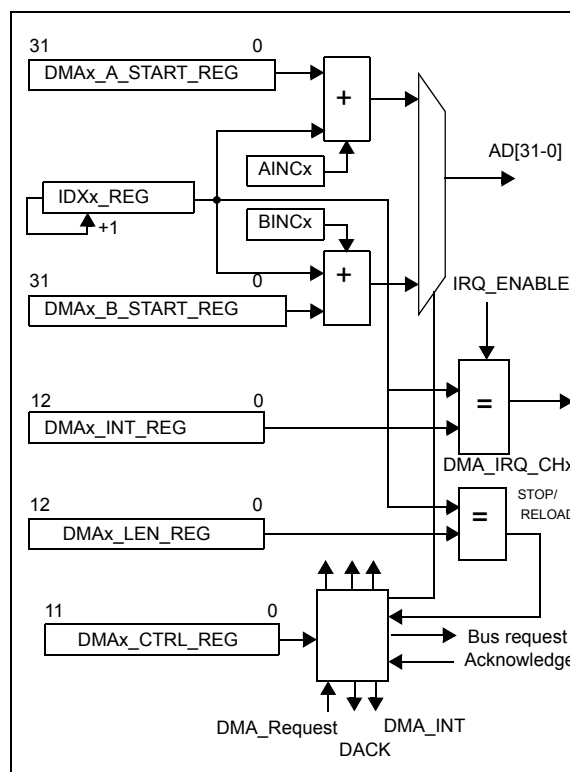

Figure 44: DMA channel diagram

If at the end of a DMA cycle, the DMA start condition is still true, the DMA continues. The DMA stops if `DREQ_MODE` is low or if `DMAx_LEN_REG` is equal to the internal index register. This condition also clears

the **DMA_ON** bit.

If bit **CIRCULAR** is set to 1, the DMA controller automatically resets the internal index registers and continues from its starting address without intervention of the ARM Cortex™ M0. If the DMA controller is started with **DREQ_MODE** =0, the DMA will always stop, regardless of the state of **CIRCULAR**.

Each DMA channel can generate an interrupt if **DMAx_INT_REG** is equal to **DMAx_IDX_REG**. After the transfer and before **DMAx_IDX_REG** is incremented, the interrupt is generated.

Example: if **DMA_x_INT_REG**=0 and **DMA_x_LEN_REG**=0, there will be one transfer and an interrupt.

13.4 DMA ARBITRATION

The priority level of a DMA channel can be set with bits **DMA_Prio[2-0]**. These bits determine which DMA channel will be activated in case more than one DMA channel requests DMA. If two or more channels have the same priority, an inherent priority applies, (see register description).

With **DREQ_MODE** = 0, a DMA can be interrupted by a channel with a higher priority if the **DMA_IDLE** bit is set. **DMA_IDLE** is a don't care if **DREQ_MODE** = 1.

When **DMA_INIT** is set, however, the DMA channel currently performing the transfer locks the bus and cannot be interrupted by any other channel, until the transfer is completed, regardless if **DMA_IDLE** is set. The purpose of **DMA_INIT** is to initialize a specific memory block with a certain value, fetched also from memory, without any interruption from other active DMA channels that may request the bus at the same time. Consequently, it should be used only for memory initialization, while when the DMA transfers data to/from peripherals, it should be set to '0'. Note also that, when **DMA_INIT** is enabled, **BINC** should be set to '1', while **AINC** is don't care, as the DMA performs a single read in this mode.

It should be noted that memory initialization could also be performed without having the **DMA_INIT** enabled and by simply setting **AINC** to '0' and **BINC** to '1', provided that the source address memory value will not change during the transfer. However, it is not guaranteed that the DMA transfer will not be interrupted by other channels of higher priority, when these request access to the bus at the same time.

13.5 FREEZING DMA CHANNELS

Each channel of the DMA controller can be temporarily disabled by writing a 1 to freeze all channels at **SET_FREEZE_REG**.

To enable the channels again, a 1 to bits at the **RESET_FREEZE_REG** must be written.

There is no hardware protection from erroneous programming of the DMA registers.

It is noted that the on-going Memory-to-Memory trans-

fers (**DREQ_MODE**='0') cannot be interrupted. Thus, in that case, the corresponding DMA channels will be frozen after any on-going Memory-to-Memory transfer is completed.

14 AES/Hash Engine

The Crypto engine aims to accelerate the algorithm calculations that are needed in order to implement the RFC4835. It implements AES in ECB, CBC and CTR modes. It also comprises HASH functions (SHA-1, SHA224/256/384/512, MD5). It supports AES128, AES 256 as well as HMAC-SHA-256 authentication protocol.

The AES/HASH engine uses a DMA engine for transferring encrypted/decrypted data to a shared memory in the AHB bus. The control registers of the IP are connected to the AHB bus.

The AES/HASH engine gives more flexibility to the way input data can be provided to the module. A calculation can be applied on fragmented input data and not on data residing at a specific memory space, by means of successive register programming in the internal DMA engine.

Features

- AES (Advanced Encryption Standard) with 128, 192 or 256 bits key cryptographic algorithm.
- HASH functions: MD5, SHA-1, SHA224/256/384/512 bits
- Modes of operation
 - ECB (Electronic Code Book)
 - CBC (Cipher Block Chaining)
 - CTR (Counter)
- AHB Master DMA machine for data manipulation.
- AHB Slave register file for configuration.

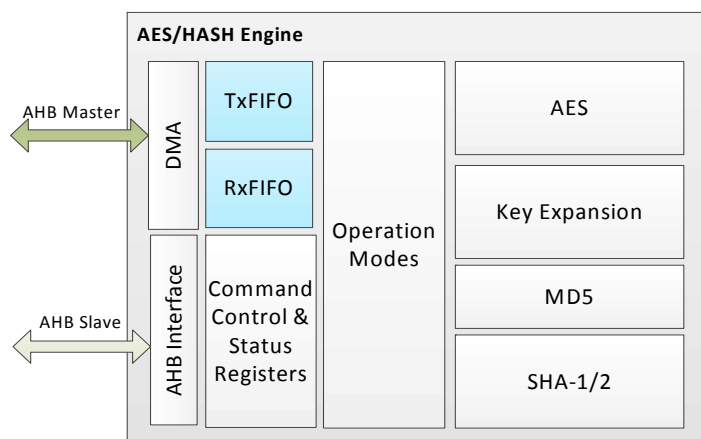

Figure 45: AES/HASH Architecture

14.1 ARCHITECTURE

14.1.1 AES/HASH engine

The architectural view of the AES/HASH engine is the following:

The AES/HASH includes a DMA engine (AHB Master Interface) for transferring data between the IP and a shared memory. The control registers of the AES/HASH are connected to AHB interface (AHB Slave interface).

The “Modes” controls the AES by implementing the respective mode that the selected encryption algorithms will operate each time. Also “Modes” communicates with DMA via two FIFO’s (RxFIFO and Tx FIFO) which isolate the operation of the AES/HASH IP from the current status of the AHB-AMBA bus and also enable parallel transmission of data in bursts. By using burst transmission, the bus is utilized better because the bus access requests are reduced.

The “Ctrl FSM” block checks the FIFO’s and DMA status continuously and decides for the amount of data traffic, plus which of the FIFO’s will be used. Also decides the “switching off” of the AES/HASH after transferring all results to the memory.

The “HASH” block contains all the logic required for the realization of the hash algorithms calculations as well as circuitry for the padding of data. It also contains glue logic for the transfer of the results to the “Modes” block.

14.1.2 AES

This part of the architecture implements the AES algorithm describing in the AES-FIPS PUB 197. The capabilities that offer are the encryption and decryption of 128 bits data blocks by using 128, 192 or 256 bits encryption key.

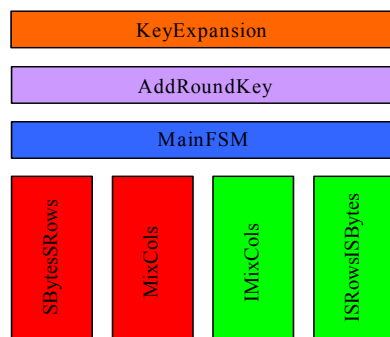

Figure 46: AES Architecture

The internal structure of the AES correlates with the logic function of the AES algorithm.

- **KeyExpansion:** The “KeyExpansion” is the process of generating the number of keys based on the initial key. More specific generates 11, 13 and 15 keys from an initial key of 128, 192 and 256 bits respectively. Each round of the algorithm uses each one of the above keys. For the encryption of each 128 bits input we need to use all generated, from this process, keys.
- **AddRoundKey:** Adds (modulo 2) the intermediate status that the input data already transformed (128 bits) with one of the generated (from “KeyExpansion”) keys. The output of this module contains the result that produced from the application of all the transformations that take place for the current round of the algorithm.
- **SBytesSRRows:** When encryption is taking place the module applies the SubBytes transformation first and then the ShiftRows transformation on the input data.
- **ISRowsISBytes:** When decryption is taking place this module applies the Inverse ShiftRows transformation and then the Inverse SubBytes on the input data.
- **MixCols:** Being used for encryption and implements the MixColumns transformation.
- **IMixCols:** Being used for decryption and implements the Inverse MixColumns transformation.
- **MainFSM:** The basic FSM that controls all previous modules. In general controls the complete AES encryption/decryption.

All parts of AES is implemented using hardware including the Key Expansion part.

14.1.3 Modes

The block “Modes” uses the AES in order to implement the following modes of operations:

- ECB (Electronic Code Book)

- CBC (Cipher Block Chaining)
- CTR (Counter)

Padding requirements of the algorithms, to convert all data to multiples of 16 bytes (for AES), must be addressed by software.

By applying successive programming of AES-CBC encryptions using software, the realization of the HMAC-XCBC-AES-96 algorithm is possible.

The implementation of the AES-CCM is feasible just like the implementation of AES-CTR algorithms for encryption, and AES-CBC for authentication.

14.1.4 HASH

The structure of the HASH block is presented in the following figure:

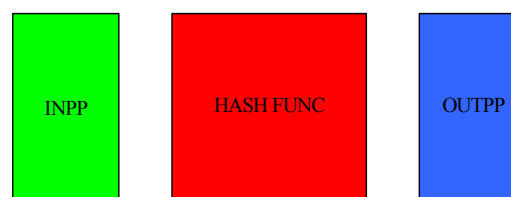

Figure 47: HASH block diagram

INPP applies padding at the input data as required by the hash algorithms. Two types of padding are implemented, due to the different algorithms supported. The purpose is to ensure that the message is a multiple of 512 bits or 1024 bits depending on the algorithm. Padding is done in a similar way in both cases. After the last data byte, one extra byte of value 0x80 is added. Next, a number of bytes (0x00) is added so that the overall size of the data block (including the extra bytes) mod 512/1024 is 448/896 depending on the algorithm. Following that, a 64/128-bits big-endian number is attached which represents the size of the data block, in bits (without the padding). While in this process, TX/RX FIFOs are switched into 8-bytes mode.

OUTPP packetizes the algorithm result (128 to 512 bits) into blocks of 64 bytes so that they can be shifted to the TX FIFO.

HASH FUNC contains the logic implementing the following hash algorithms:

1. MD5: RFC1321
2. SHA-1: FIPS PUB 180-4
3. SHA-224/256: FIPS PUB180-4. In this case only initialization changes.
4. SHA-384/512: FIPS PUB 180-4

As depicted in the following figure, HASH FUNC comprises common and specific resources for all algorithms.

All registers are contained in the common resources. Also, 2 32-bit adders utilized by all hash algorithms are part of the common resources.

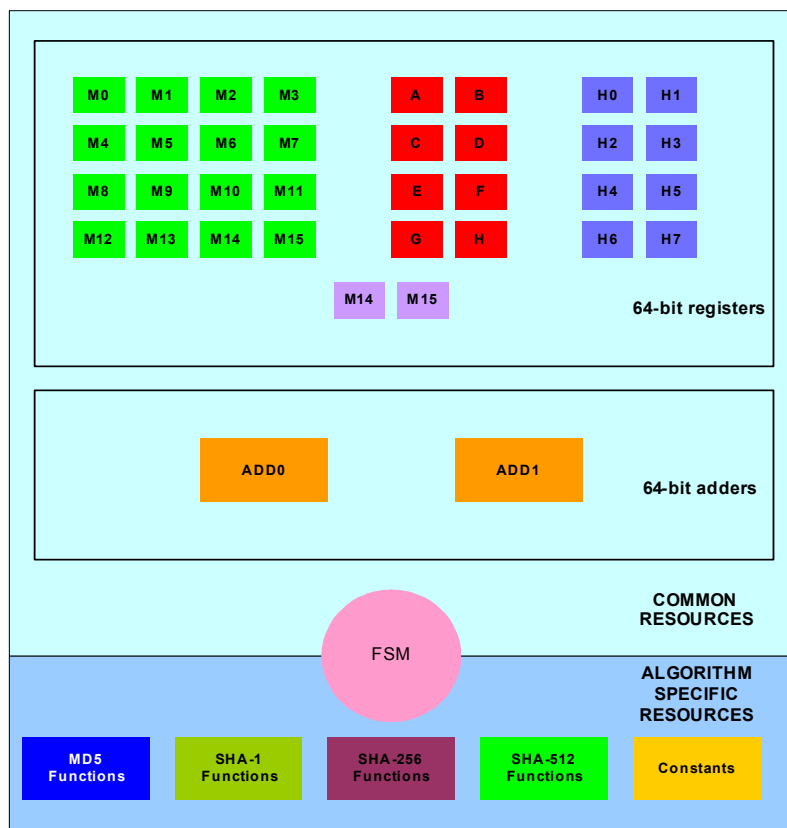

Figure 48: HASH FUNC architecture

14.2 PROGRAMMING

The basic register for the programming of AES/HASH engine is the CRYPTO_CTRL_REG. Select the cryptographic algorithm by setting the CRYPTO_ALG register. The mode of operation can be programmed by choosing the suitable value for the CRYPTO_ALG_MD register. When only the final block of the resulting data must be stored at the memory, the user should set the CRYPTO_OUT_MD=1. The encryption/decryption function is selected by programming the CRYPTO_ENCDEC register. If the selected algorithm is the AES, the CRYPTO_AES_KEY_SZ register should be used to set the key size of the algorithm. To generate an interrupt request at the end of the operation, CRYPTO_IRQ_EN=1 should be set.

Proportionally with the selected cryptographic algorithm and the selected mode of operation, read the CRYPTO MREGs table and program the suitable registers with the parameters of the selected algorithms.

Flag CRYPTO_AES_KEXP controls key expansion. With CRYPTO_AES_KEXP=1, key expansion will be performed by the dedicated hardware engine. Otherwise key expansion should be performed by software

and generated keys should be stored into CRYPTO_KEYS memory.

In case of CRYPTO_AES_KEXP = 1, CRYPTO_KEYS_START should be programmed with the cipher key.

The source address is set by writing the CRYPTO_FETCH_ADDR_REG register. The AES/HASH engine reads the input data from this memory location.

The destination address is set by writing the CRYPTO_DEST_ADDR_REG register. The AES/HASH engine writes the output data to this memory location.

The calculation is started by setting CRYPTO_START_REG=1.

The end of calculation is indicated by the CRYPTO_INACTIVE flag when CRYPTO_MORE_IN=0. If not, the processing of the current data input is denoted by CRYPTO_WAIT_FOR_IN. When CRYPTO_INACTIVE=1, the calculation is finished and the resulting data are in the memory. When

CRYPTO_WAIT_FOR_IN=1 more data are to be processed. In both cases, if CRYPTO_IRQ_EN=1, an interrupt request is generated.

To clear an interrupt request from the AES/HASH engine, CRYPTO_CLRIRQ=1 should be programmed.

For the hash functions activation, the CRYPTO_HASH_SEL field in the CRYPTO_CTRL_REG has to be set. When this bit is set, the CRYPTO_ALG field refers to the hash algorithms rather than the encryptions algorithms. CRYPTO_ALG_MD selects between HASH algorithms based on 32 or 64-bit arithmetic. Table 30 shows the programming selection of the hash algorithms. With means of the CRYPTO_HASH_OUT_LEN, the number of bytes to be eventually used is defined. This number is programmable ranging from 1 to 64.

Table 30: Hash function selection

CRYPTO_ALG_MD	CRYPTO_ALG	Hash algorithm
00	00	MD5
00	01	SHA-1
00	10	SHA-256/224
00	11	SHA-256
01	00	SHA-384
01	01	SHA-512
01	10	SHA-512/224
01	11	SHA-512/256

Note that there are some restrictions for the number of bytes to be processed (CRYPTO_LEN value) that are related to the algorithm currently in use (CRYPTO_HASH_SEL and CRYPTO_ALG), the mode of operation (CRYPTO_ALG_MD) and whether there are more data to be consumed (CRYPTO_MORE_IN) as depicted in the following table:

Table 31: Restrictions on CRYPTO_LEN

ALGORITHM	CRYPTO_HASH_SEL	CRYPTO_ALG_MD	CRYPTO_ALG	CRYPTO_LEN CRYPTO_MORE_IN = 0	CRYPTO_LEN CRYPTO_MORE_IN = 1
AES ECB	0	00	00	multiple of 16	multiple of 16
AES ECB		01	00	multiple of 16	multiple of 16
AES CTR		10	00	no restriction	multiple of 16
AES CBC		11	00	no restriction	multiple of 16

Table 31: Restrictions on CRYPTO_LEN

ALGORITHM	CRYPTO_HASH_SEL	CRYPTO_ALG_MD	CRYPTO_ALG	CRYPTO_LEN CRYPTO_MORE_IN = 0	CRYPTO_LEN CRYPTO_MORE_IN = 1
MD5	1	00	00	no restriction	multiple of 8
SHA-1		00	01	no restriction	multiple of 8
SHA-256/224		00	10	no restriction	multiple of 8
SHA-256		00	11	no restriction	multiple of 8
SHA-384		01	00	no restriction	multiple of 8
SHA-512		01	01	no restriction	multiple of 8
SHA-512/224		01	10	no restriction	multiple of 8
SHA-512/256		01	11	no restriction	multiple of 8

The amount of clock cycles required to perform a HASH or an encryption/decryption/key expansion task, is presented in the following table:

Table 32: Latency of various crypto algorithms

Algorithm	Activity	Clock Cycles / Block	Block Size (bits)	Clock Cycles for 256 kB (M)
MD5	Hash	231	512	0.95
SHA-1	Hash	281	512	1.15
SHA-256/224	Hash	423	512	1.73
SHA-256	Hash	423	512	1.73
SHA-384	Hash	565	1024	1.16
SHA-512	Hash	565	1024	1.16
SHA-512/224	Hash	565	1024	1.16
SHA-512/256	Hash	565	1024	1.16
AES-128	Key Expansion	54		
AES-128	Encryption	86	128	1.41
AES-192	Key Expansion	59		
AES-192	Encryption	101	128	1.65
AES-256	Key Expansion	70		
AES-256	Encryption	117	128	1.92

15 ECC Engine

The ECC Engine is a very flexible block based on a 4x4 array of Dual-Field Processing Elements (DFPEs) that can be used to execute all operations & algorithms required for Elliptic Curve Cryptography systems such as Diffie-Hellman (ECD-H) Key Exchange and Elliptic Curve Digital Signature Algorithm (ECDSA). The ECC engine is flexible enough to support any other crypto algorithm since it comprises a μ -Code based controller which reads code from a dedicated RAM, making upgrades possible.

A powerful dedicated ALU consisting of 4 16x16 multipliers (DFPEs) combined with an effective pipelining scheme, allows for maximum throughput while preserving a small memory footprint. A Tightly Coupled Memory (TCM) assists in the intermediate results storage without creating traffic on the system's bus and memory.

The ECC engine comes with an APB interface for configuration and a DMA engine for data transactions to and from the DataRAM of the DA14681 without the interference of the CPU.

Features

- RAM-based sequencer gives a maximum of flexibility and facilitates functional upgrades
- Supports arbitrary data/key sizes for ECC (up to 256 bits)
- Supports high-level PK Algorithms (ECDSA, ECDH, EdDSA)
- Low memory requirements:
 - 2 kBytes from system's DataRAM
 - 2 kBytes for the TCM
 - 3 kBytes for the μ -Code RAM (retainable)
- High throughput: 90 256-bit ECC-point multiplications per second at 96 MHz

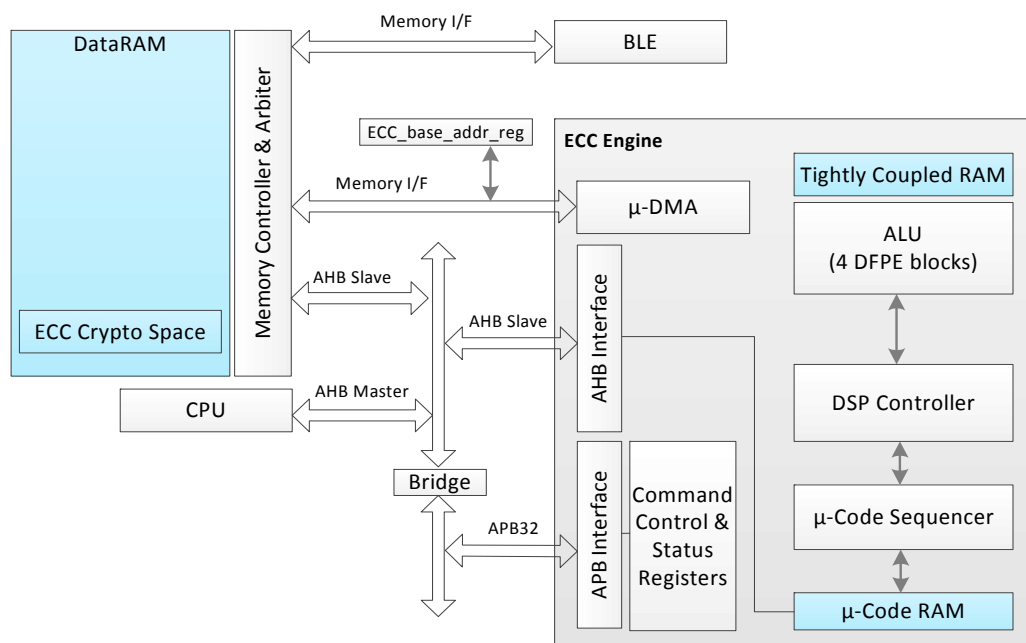

Figure 49: ECC Engine Block Diagram

15.1 ARCHITECTURE

The ECC controller comprises an AHB interface which is used for downloading the respective curve into the 3 kB μ -Code RAM which can be retained during any Sleep mode (PMU_CTRL_REG[RETAIN_ECCRAM]). The source of this μ -Code might be the ECC Section of the OTP header (see Table 5) or any other RAM or FLASH location. The μ -Code RAM base address is at 0x40030000. There is also, an APB32 interface which is used for accessing the block's registers at base

address 0x50006000. Finally, it includes an memory interface which directly connects to the memory controller of the DA14681 and uses a memory space with pre-defined base address as the buffer for data in and data out such as e.g. curve parameters and signature generation results. The pre-defined address is configured by ECC_BASE_ADDR_REG which allocates memory in pages of 1 kB.

The DSP controller is responsible for the primitive calculation with help of the ALU and its dedicated 2 kB of

tightly coupled memory used to store intermediate variables.

15.1.1 Supported curves

Due to the flexible architecture any curve should be able to implement in μ -Code. The currently available are:

- NIST recommended Curves:
 - Prime Field P-192, P-224, P-256
 - Binary Field K-163, K-233
 - Binary Field B-163, B-233
- Brainpool and SEC2 Curves
- Curve25519
- Average μ -Code size for these curves is 3 kB.
- Average clock cycle amount for executing each curve is 100 k cycles

15.1.2 Supported high level algorithms

A number of cryptography algorithms involving other hardware resources than just the ECC are available as described in the following table, including their latency in system clock cycles:

Table 33: ECC algorithms latency

Algorithm	Routine	ECC cycles (M)
JPAKE-p256	step1_generate	4.5
	step1_verify	4.5
	step2_generate	2.3
	step2_verify	2.3
	seskey_generate	2.3
EdDSA - Ed25519	pk_generate	0.7
	sign_generate	0.7
	sign_verify	1.4
ECDH - Curve25519	pk_generate	0.5
	seskey_generate	0.5
ECDH - P256	pk_generate	1.1
	seskey_generate	1.1
ECDSA - P256	pk_generate	1.1
	sign_generate	1.15
	sign_verify	2.3
ECKCDSA - P256	pl_generate	1.1
	sign_generate	1.2
	sign_verify	2.2

15.2 PROGRAMMING

In order to interact with the ECC several steps are necessary. At first the ECC Crypto Module needs to get started and initialized:

At first the ECC Crypto Module needs to get started and initialized:

- Enable clock to the ECC Crypto Module at CLK_AMBA_REG[ECC_CLK_ENABLE]
- Specify address space inside DataRAM to be used by the ECC block by programming the ECC_BASE_ADDR_REG
- Load micro code into ECC u-Code RAM starting at address 0x40030000. The microcode itself can be located in the OTP header inside the Elliptic curve content section (ECS), or in the FLASH
- In case the interrupt is to be used, the corresponding IRQ vector needs to be provided and the IRQ needs to get enabled both in the Interrupt controller and the ECC block by programming

Before executing any arithmetic operation, all required parameters, operands and data must be written in the shared memory whose address is defined at ECC_BASE_ADDR_REG.

Depending on the operations to execute, some parameters or operands (like the prime modulus N or P) must be located in pre-defined/fixed addresses while some other input/output operands and results can be passed to/from programmable addresses by using specific pointers (ECC_OPPTRA, ECCOPPTRB and ECC_OPPTRC) in the configuration register ECC_CONFIG_REG.

The programming flow is illustrated in [Figure 50](#)

Please note that the size of the individual operands must not exceed 256bit. However operand widths of 64bit as well as 128bit are also supported. In the arithmetic unit all operands are executed on blocks whose length is a multiple of 64bit. If needed input data that are written in memory must be extended with zeroes to get the right length (defined size of operands). Data is stored in the crypto memory following the little endian format.

15.2.1 Example: ECDSA signature generation

As explained in the previous section, some of the parameters or operands need to be available at predefined fixed addresses before starting the execution of the ECDSA signature generation. They all reside in the ECC crypto space in the DataRAM. The following table describes the actual sequence of the steps required and their respective commands.

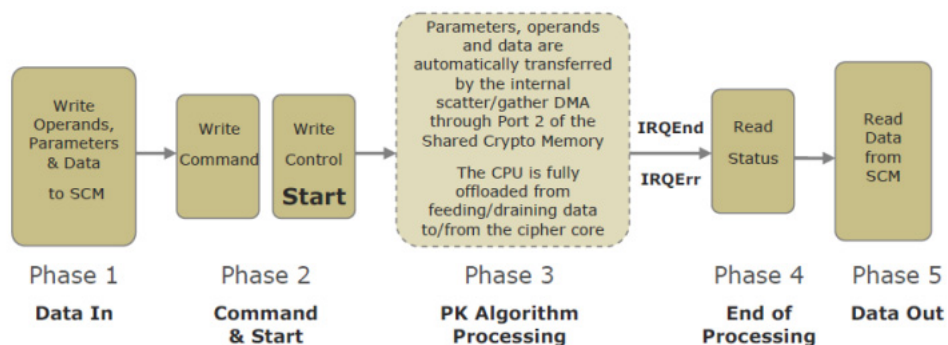

Figure 50: ECC programming flow

Table 34: ECDSA Signature Generation Process

Step	Operation	Command
1	select $k < n$	Use TRNG block
2	Compute $h = \text{SHA-1}(m)$ Store h	Use HASH block
3	Compute $P_1 = k \cdot G$	$P_1(x_1, y_1) = k \cdot G(x_G, y_G) = \text{Point_Mul}(k, G)$
4	Compute $r = x_1 \bmod n$ If $r=0$ then go to Step 1	$r = \text{MODRED}(x_1, n)$ Check_r
5	Compute $w = k^{-1} \bmod n$	$w = \text{MODINV}(k, n)$
6	Compute $s = k^{-1} (h + d \cdot r) \bmod n$ If $s=0$ then go to Step 1	$d \cdot r = \text{MODMUL}(d, r, n)$ $h + d \cdot r = \text{MODADD}(h, d \cdot r, n)$ $s = \text{MODMUL}(k^{-1}, h + d \cdot r, n)$
7	(r, s) is the signature for the message m	
		Check Status Register (ECC_STATUS_REG[ECC_BUSY])

where:

- $G(x_G, y_G)$ is the generator point of the elliptic curve chosen,
- n is the order of point G
- h is the 160 bits hash digest of the message m
- d is the private key ($d < n$)

The layout of the ECDSA signature generation in terms of the actual parameters and operands to be used by the u-Code is shown in the following table:

Table 35: ECC ECDSA Signature Generation memory layout

Addr	Operand	Note
0x0	p or q or	Pre-defined
0x1	n	Pre-defined
0x2	$x_G/G(x)$	Pre-defined
0x3	$y_G/G(y)$	Pre-defined

Table 35: ECC ECDSA Signature Generation memory layout

Addr	Operand	Note
0x4	a	Pre-defined
0x5	b	Pre-defined
0x6	d (private key)	Pre-defined
0x7	k	Pre-defined
0x8	$x_Q/Q(x)$ Public Key	
0x9	$y_Q/Q(y)$ Public Key	
0xA	r	Result
0xB	s	Result
0xC	$h = \text{SHA-1}(m)$	Pre-defined
0xD	w	
0xE	$P_1(x) = (k \cdot G)(x)$	
0xF	$P_1(y) = (k \cdot G)(y)$	

Parameters or operands noted as “Pre-defined” should be available at this specific pre-defined fixed address before generating the ECDSA Signature. The actual signature (r, s) is available at locations 0xA and 0xB.

The above memory layout represents the actual memory description of the shared ECC memory (part of the DataRAM).

16 True Random Number Generator (TRNG)

The TRNG is a non-deterministic Random Number generator used to provide the seed for encryption processes.

Its output can be used as entropy input for a FIPS 140-2 approved deterministic random number generation process which is handled by SW and HW accelerators of the DA14681.

The TRNG contains oscillator rings in digital logic which combined create metastability on a Flip-Flop eventually being the source of the entropy bits.

Features

- Optional NIST SP800-90A Hash_DRBG post processing using SHA-256 function using the on-chip HW accelerators
- Random numbers access through 32x32 bits FIFO on AHB bus
- Dedicated TRNG_IRQ Interrupt line
- Start-up time 512 pclk cycles per 32 random bits
- Clock enable signals for optimal power saving

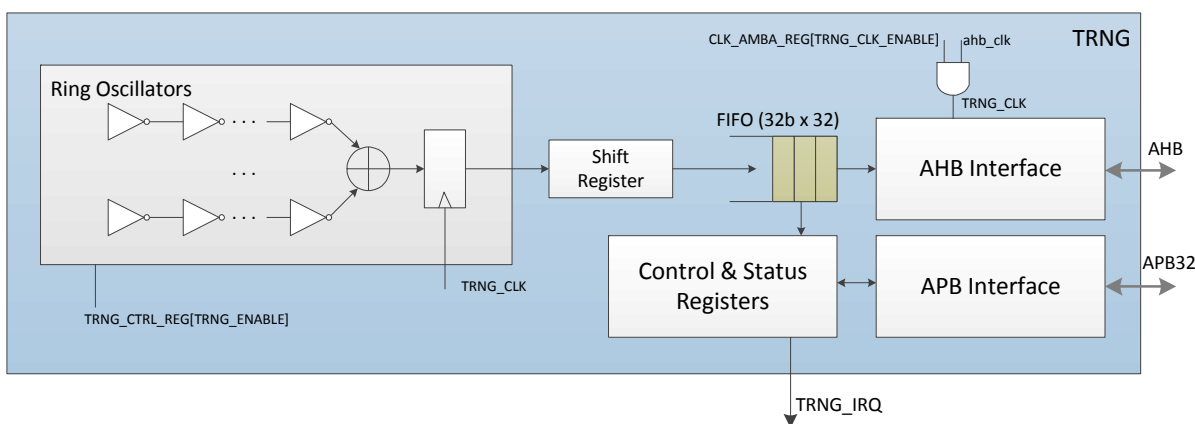

Figure 51: TRNG block diagram

16.1 ARCHITECTURE

Figure 51 shows the TRNG block diagram.

The TRNG comprises a number oscillator rings consisting of several inverters each. The output of the oscillator rings are accumulated in a shift register for whitening before being stored in a 32x32 bits deep FIFO. The oscillator rings are enabled when the TRNG_CTRL_REG[TRNG_ENABLE] is set and as long as the FIFO is not full.

The 32-bit random numbers are accessible via an AHB interface while the registers are accessible via the APB32 interface.

16.2 PROGRAMMING

There is a simple sequence of steps that need to be followed to program the TRNG engine:

1. Set CLK_AMBA_REG[TRNG_CLK_EN]=1 to enable the AHB bus access
2. Set TRNG_CTRL_REG[TRNG_MODE]=0 to select the ring oscillators rather than a pseudo random generator
3. Set TRNG_CTRL_REG[TRNG_ENABLE]=1 to start the random number generation. This signal is ignored when the FIFO is already full

4. Poll TRNG_FIFOLVL_REG which provides the amount of data in the FIFO, or wait for the TRNG_IRQ
5. Read the random number from the TRNG FIFO at address 0x40040000 (TRNG_M)
6. To save power, set TRNG_CLK_EN=0 and set TRNG_ENABLE=0. The FIFO can only be accessed if TRNG_CLK_EN=1

Note that, all signals are handled following the little-endian format. That means that the Least Significant Byte (LSB) is stored at the lowest address.

16.2.1 Latency

After TRNG_CTRL_REG[TRNG_ENABLE] is set to 1, it takes 512 pclk clock cycles/FIFO entry. So for 32 FIFO entries $512 \times 32 = 16K$ pclk clock cycles or 1 ms if the 16 MHz clock is used.

17 Temperature Sensor

The DA14681 has a built-in temperature sensor which is part of the charging circuit and protects the die against too high temperature. It can however be used as a temperature sensor even if the charging circuit is not activated.

Features

- Supply voltage 1.9 V - 3.6 V
- Temperature range -40 °C to 100 °C
- Uncalibrated (3 sigma) accuracy of +/- 17 °C
- Accuracy after 1 point calibration +/- 8.8 °C. (Assuming perfect reference temperature)
- Accuracy after 2 points calibration +/- 4 °C. (Assuming perfect reference temperature)

17.1 PROGRAMMING

The temperature sensor can be read out through the GPADC, even when the charger is off, by setting:

- CHARGER_CTRL2_REG[CHARGER_TEST]=1
- GP_ADC_CTRL_REG[GP_ADC_SEL]=14

The formulas which provide the relation between ADC_x values (in LSBs) and the actual temperature T_x (in °C) are explained below.

For uncalibrated measurements:

- $T_x = (ADC_x - 712) / 2.44$

For one point calibration measurements:

- Measure T_{1p_cal} with a thermometer, and read ADC_{1p_cal}
- $T_x = T_{1p_cal} + (ADC_x - ADC_{1p_cal}) / 2.44$

For two points calibration measurements:

- Measure T_{2p_cal_1} with a thermometer, and read ADC_{2p_cal_1}
- Measure T_{2p_cal_2} with a thermometer, and read ADC_{2p_cal_2}. It is recommended that T_{2p_cal_2} - T_{2p_cal_1} > 40 °C to achieve best accuracy.
- Calculate $T_c = (ADC_{2p_cal_2} - ADC_{2p_cal_1}) / (T_{2p_cal_2} - T_{2p_cal_1})$
- $T_x = T_{2p_cal_1} + (ADC_x - ADC_{2p_cal_1}) / T_c$

Please note that, while measuring and/or calibration, the system's power dissipation should be kept the same, or else the measurement is affected by the internal thermal gradient.

18 Wakeup Timer

The Wakeup Timer can be programmed to wake up the DA14681 from power down mode after a pre-programmed number of GPIO events.

Each of the GPIO inputs can be selected to generate an event by programming the corresponding WKUP_SELECT_Px_REG register. When all WKUP_SELECT_Px_REG registers are configured to generate a wakeup interrupt, a toggle on any GPIO will wake up the system.

The input signal edge can be selected by programming the WKUP_POL_Px_REG register.

The block diagram illustrating the Wake Up function is shown in Figure 52.

Features

- Monitors any GPIO state change
- Implements debouncing time from 0 upto 63 ms
- Accumulates external events and compares the number to a programmed value
- Generates an interrupt to the CPU

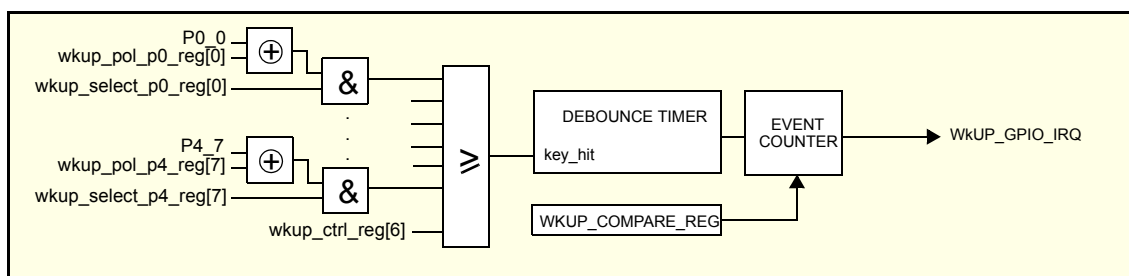

Figure 52: Wakeup Timer block diagram

A LOW to HIGH level transition on the selected input port, while WKUP_POL_Px_REG[y] = 0, sets internal signal “key_hit” to ‘1’. This signal triggers the event counter state machine as shown in Figure 53.

The debounce timer is loaded with value WKUP_CTRL_REG[WKUP_DEB_VALUE]. The timer counts down every 1 ms. If the timer reaches 0 and the “key_hit” signal is still ‘1’, the event counter will be incremented.

The event counter is edge sensitive. After detecting an active edge a reverse edge must be detected first before it goes back to the IDLE state and from there starts waiting for a new active edge.

If the event counter is equal to the value set in the WKUP_COMPARE_REG register, the counter will be reset and an interrupt will be generated, if it was enabled by WKUP_CTRL_REG[ENABLE_IRQ].

The interrupt can be cleared by writing any value to register WKUP_RESET_IRQ_REG.

The event counter can be reset by writing any value to register WKUP_RESET_CNTR_REG.

The value of the event counter can be read at any time by reading register WKUP_COUNTER_REG.

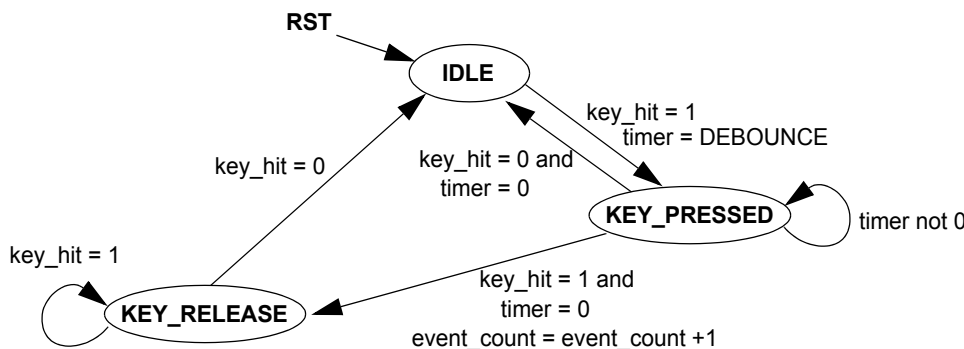

Figure 53: Event counter state machine for the Wakeup interrupt generator

19 General purpose ADC

The DA14681 is equipped with a high-speed ultra low power 10-bit general purpose Analog-to-Digital Converter (GPADC). It can operate in unipolar (single ended) mode as well as in bipolar (differential) mode. The ADC has its own voltage regulator (LDO) of 1.2 V, which represents the full scale reference voltage.

Features

- 10-bit dynamic ADC
- Maximum sampling rate 4 Msample/s
- Ultra low power (5 μ A typical supply current at 100 ksamples/s)

- Single-ended as well as differential input with two input scales
- Eight single-ended or two differential external input channels
- Oversampling up to 128 steps providing effectively up to 11.2 bits precision (ENOB)
- Battery monitoring function
- Chopper function
- Offset and zero scale adjust
- Common-mode input level adjust
- DMA support

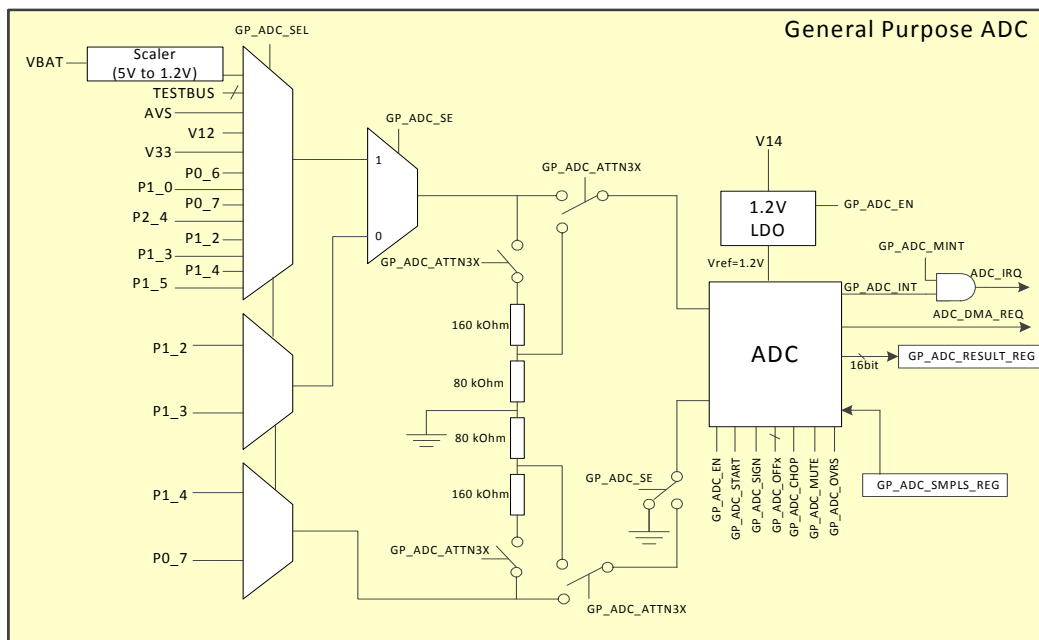

Figure 54: Block diagram of the General Purpose ADC

19.1 ARCHITECTURE

The ADC architecture shown in Figure 54 has the following sub blocks:

- Analog to Digital converter (ADC)
 - ADC analog part internally clocked with 100 MHz (default) or the ADC_CLK selectable with GP_ADC_CTRL_REG[GP_ADC_CLK_SEL]
 - ADC logic part clocked with the ADC_CLK (16 MHz or 96 MHz) with CLK_PER_REG[ADC_CLK_SEL]
- 1.2V LDO for the ADC supply with a high PSRR enabled with GP_ADC_CTRL_REG[GP_ADC_EN]
- APB Bus interface clocked with the APB clock. Control and status registers are available through registers GP_ADC_*
- Maskable Interrupt (ADC_IRQ) and DMA request

(ADC_DMA_REQ)

- ADC Input channels selector. Up-to eight specific GPIO ports, battery voltage (VBAT1) and the analog ground level (AVS) can be measured.

The ADC has the following modes of operation as shown in Figure 55:

- Manual mode
 - Continuous mode
- In both modes the ADC performance might be increased by enabling:
- Oversampling mode
 - Chopper mode

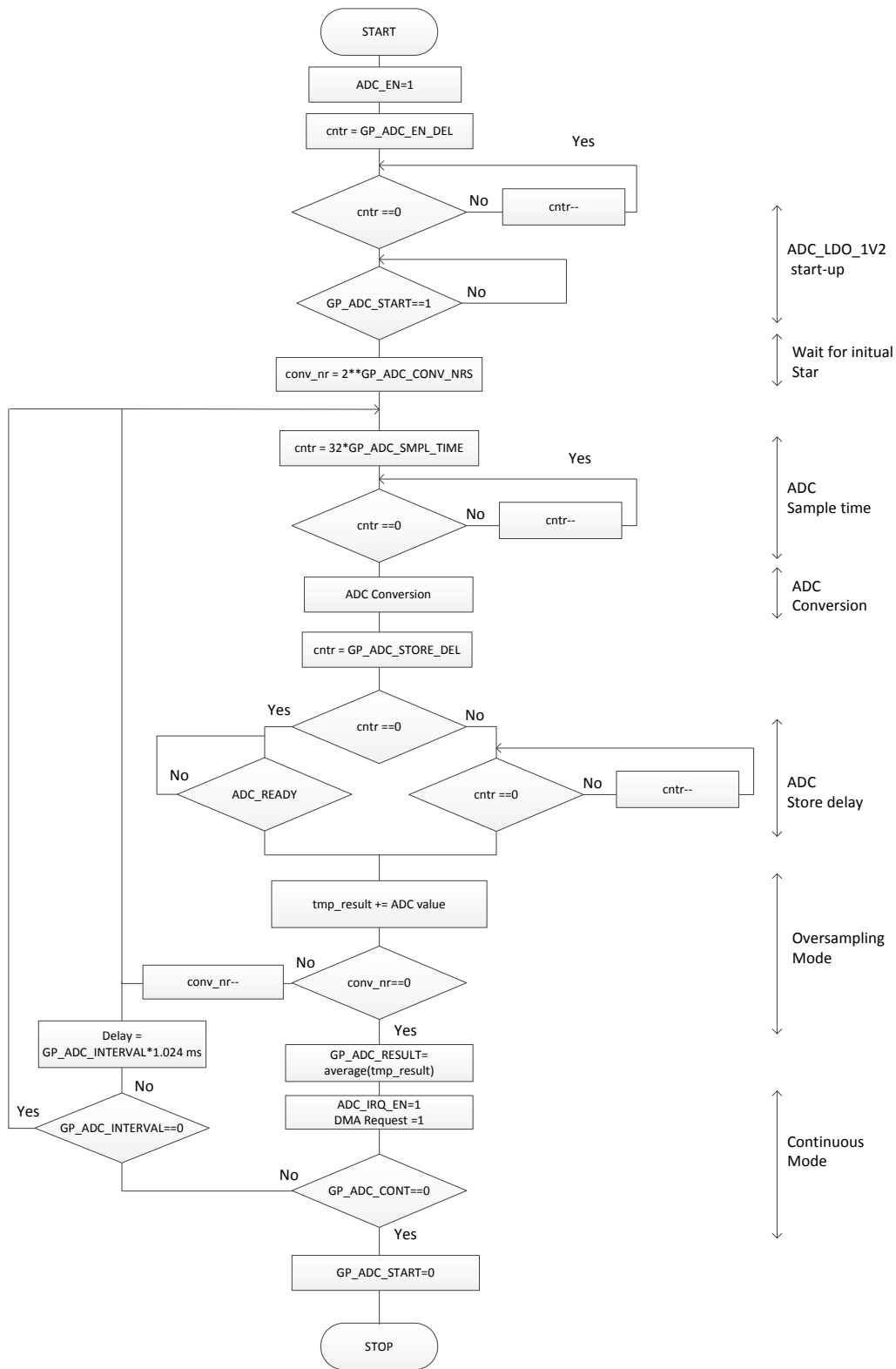

Figure 55: GPADC operation flow diagram

19.2 INPUT CHANNELS AND INPUT SCALE

The DA14681 has a multiplexer between the ADC and eight specific GPIO ports which can be sampled. Furthermore, the ADC can also be used to monitor the battery voltage (VBAT1) and the analog ground level (AVS).

Single-ended or differential operation for the external

channels is selected via bit GP_ADC_CTRL_REG[GP_ADC_SE]. In differential mode the voltage difference between two GPIO input ports will be converted via bit GP_ADC_CTRL2_REG[GP_ADC_ATTN3X] the input scale can be enlarged by a factor of three, as summarized in [Table 36](#).

Table 36: GPADC input channels and voltage scale

GP_ADC_ATTN3X	GP_ADC_SE	Input channels	Input scale	Input limits
0	1	P0_6, P1_0, P0_7, P2_4, P1_2, P1_3, P1_4, P1_5	0 V to +1.2 V	-0.1 V to +1.3 V
0	0	[P1_2, P1_4], [P1_3, P0_7]	-1.2 V to +1.2 V	-1.3 V to +1.3 V
1	1	P0_6, P1_0, P0_7, P2_4, P1_2, P1_3, P1_4, P1_5	0 V to +3.6 V	-0.1 V to +3.45 V
1	0	[P1_2, P1_4], [P1_3, P0_7]	-3.6 V to +3.6 V	-3.45 V to +3.45 V

19.3 STARTING THE ADC

The GPADC is a dynamic ADC and consumes no static power, except for the LDO which consumes less than 5 μ A.

Enabling/disabling of the ADC is triggered by configuring bit GP_ADC_CTRL_REG[GP_ADC_EN]. When set, first the LDO is enabled, then after the delay value set in GP_ADC_CTRL3_REG[GP_ADC_EN_DEL] (recommended value is 20 μ s to account for LDO settling time) the ADC will be enabled and an AD-conversion can be started.

See [Table 37](#) for recommended values.

The ADC LDO consumes about 5 μ A, so GP_ADC_EN must be set to 0 if the ADC is not used.

Table 37: ADC_LDO_1V2 start-up time

ADC_CLK (MHz)	GP_ADC_EN_DEL	Delay (μ s)
16	0x0B	22.0
96	0x40	21.3

19.4 ADC CONVERSION MODES

19.4.1 Manual Mode

Each conversion has two phases: the sampling phase and the conversion phase. When bit GP_ADC_CTRL_REG[GP_ADC_EN] is set to '1', the ADC samples the selected input voltage. Writing a '1' at bit GP_ADC_CTRL_REG[GP_ADC_START] ends the sampling phase and triggers the conversion phase. When the conversion is ready, the ADC resets bit GP_ADC_START to '0' and returns to the sampling phase asserting the interrupt line GP_ADC_INT. SW should always check that GP_ADC_START=0 before starting a new conversion.

The conversion itself is fast and takes approximately one clock cycle of 16 MHz, though the data handling will require several additional clock cycles, depending

on the software code style. The fastest code can handle the data in four clock cycles of 16 MHz, resulting to a highest sampling rate of 16 MHz/5 = 3.3 Msample/s.

At full speed the ADC consumes approximately 50 μ A. If the data rate is less than 100 ksamples/s, the current consumption will be in the range of 5 μ A.

19.4.2 Continuous Mode

Setting GP_ADC_CTRL_REG[GP_ADC_CONT] to '1' it is possible to use the ADC in a continuous mode meaning that a new conversion will be started after the previous conversion has finished without using the GP_ADC_START bit. Still the GP_ADC_START bit is needed to trigger the first conversion but following that, new converted data will be generated automatically. To correctly terminate this mode it is required to disable the GP_ADC_CONT bit first and afterwards wait until the GP_ADC_START bit is cleared so the ADC is in a defined state. By using GP_ADC_CTRL3_REG[GP_ADC_INTERVAL] it is possible to determine the time interval between conversions. If kept zero, the conversion will be restarted immediately. With values different than zero, it is possible to program how many milliseconds it should take before restarting a new conversion. If GP_ADC_INTERVAL is not zero, it can take up to one millisecond before the first conversion is executed because it is synchronized to a one millisecond periodic signal.

19.5 NON-IDEAL EFFECTS

Besides Differential Non-Linearity (DNL) and Integral Non-Linearity (INL), each ADC has a gain error (linear) and an offset error (linear). The gain error of the GPADC slightly reduces the effective input scale (up to 50 mV). The offset error causes the effective input scale to become non-centred. The offset error of the GPADC is less than 20 mV and can be reduced by chopping or by offset calibration.

The ADC result will also include some noise. If the

input signal itself is noise free (inductive effects included), the average noise level will be ± 1 LSB. Taking more samples and calculating the average value will reduce the noise and increase the resolution.

With a 'perfect' input signal (e.g. if a filter capacitor is placed close to the input pin) most of the noise comes from the low-power voltage regulator (LDO) of the ADC. Since the DA14681 is targeted for ultra-compact applications, there is no pin available to add a capacitor at this voltage regulator output.

The dynamic current of the ADC causes extra noise at the regulator output. This noise can be reduced by setting bits GP_ADC_CTRL2_REG[GP_ADC_I20U] and GP_ADC_CTRL2_REG[GP_ADC_IDYN] to '1'. Bit GP_ADC_I20U enables a constant 20 μ A load current at the regulator output so that the current will not drop to zero. Bit GP_ADC_IDYN enables a 10 μ A load current during sampling phase so that the load current during sampling and conversion phase becomes approximately the same.

19.6 SAMPLING TIME (SMPL_TIME)

The default ADC sampling time is sufficient in normal operation to achieve 10 bit accuracy. If ATTN3X is enabled or the VBAT channel is selected, additional (internal) resistance is routed in series with the sampling capacitor, therefore it requires more time to settle to the same accuracy. In general, enabling ATTN3X results in a time-constant $t=60$ nsec, and sampling VBAT has a time-constant $t=500$ nsec. The total sampling time required for a given accuracy can be calculated using: $T_{\text{sample}} = -\ln(1.2/2^N) \cdot t$, where N is the desired accuracy in bits and t the time-constant mentioned before. The corresponding value for the SMPL_TIME can then easily be determined e.g. sampling VBAT with 10b accuracy and ADC_CLK=16MHz requires SMPL_TIME=2, or ATTN3X enabled requires SMPL_TIME=1 for 10b accuracy when ADC_CLK=16MHz. Obviously, when oversampling is used, the expected accuracy increases. Most of the times, setting SMPL_TIME to "1" or "2" will be sufficient. If VBAT is selected, SMPL_TIME=3 is the preferred value when oversampling (this gives 11b sampling accuracy).

19.7 OVERSAMPLING

In this mode multiple successive conversions will be executed and the results are added together to increase the effective number of bits (ENOB). The number of conversions that are executed is programmable at GP_ADC_CTRL2_REG[GP_ADC_CONV_NRS]. The six least significant bits inside the GP_ADC_RESULT_REG can be discarded if no oversampling is used. But if, for example, four samples are programmed, two extra bits are generated and only the

four least significant bits can be discarded. T

Table 38: Oversampling mode effective number of bits

Oversampling (GP_ADC_CONV_NRS)	Effective number of bits (ENOB) in GP_ADC_RESULT_REG
1	9.05
2	9.45
4	9.83
8	10.21
16	10.52
32	10.85
64	11.10
128	11.27

The preferred settings for acquiring the results of Table 38 are the following:

Table 39: Preferred settings for ENOB measurements

Description	Register Setting
Run digital at PLL speed	PLL_SYS_CTRL1_REG[PLL_EN]=1
Use internal 100MHz clock as SAR clock.	GP_ADC_CTRL_REG[GP_P_ADC_CLK_SEL]=0
Use auto zero and reference sampling in the LDO to suppress noise	GP_ADC_CTRL_REG[GP_P_ADC_LDO_ZERO]=1
Disable chopping (default)	GP_ADC_CTRL_REG[GP_P_ADC_CHOP]=0
Sign is not inverted (default)	GP_ADC_CTRL_REG[GP_P_ADC_SIGN]=0
Measure single ended	GP_ADC_CTRL_REG[GP_P_ADC_SE]=1
Single-Ended: P1[2]	GP_ADC_CTRL_REG[GP_P_ADC_SEL]=0
Enable dynamic LDO current load	GP_ADC_CTRL2_REG[GP_ADC_IDYN]=1
Enable static LDO 20A current load	GP_ADC_CTRL2_REG[GP_ADC_I20U]=1
32 ADC clock cycles sampling time	GP_ADC_CTRL2_REG[GP_ADC_SMPL_TIME]=1
Negative Offset centred (zero offset)	GP_ADC_OFFN_REG=0x200
Positive Offset centred (zero offset)	GP_ADC_OFFP_REG=0x200

19.8 CHOPPING

Chopping is a technique to cancel offset by taking two samples with opposite signal polarity. This method also smooths out other non-ideal effects and is recommended for DC and slowly changing signals.

Chopping is enabled by setting bit GP_ADC_CTRL_REG[GP_ADC_CHOP] to '1'.

The mid-scale value of the ADC is the 'natural' zero point of the ADC (ADC result = 511.5 = 1FF or 200 Hex = 01.1111.1111 or 10.0000.0000 Bin). Ideally this corresponds to $V_i = 1.2V/2 = 0.6 V$ in single-ended mode and $V_i = 0.0 V$ in differential mode.

If bit GP_ADC_CTRL2_REG[GP_ADC_ATTN3X] is set to '1', the zero point is 3 times higher (1.8 V single-ended and 0.0 V differential).

With bit GP_ADC_CTRL_REG[GP_ADC_MUTE], the ADC input is switched to the centre scale input level, so the ADC result ideally is 511.5. If instead a value of 515 is observed, the output offset is +3.5 (adc_off_p = 3.5).

With bit GP_ADC_CTRL_REG[GP_ADC_SIGN] the

sign of the ADC input and output is changed. Two sign changes have no effect on the signal path, though the sign of the ADC offset will change.

If $adc_off_p = 3.5$ the ADC_result with opposite GP_ADC_SIGN will be 508. The sum of these equals $515 + 508 = 1023$. This is the mid-scale value of an 11-bit ADC, so one extra bit due to the over-sampling by a factor of two.

The LSB of this 11-bit word should be ignored if a 10-bit word is preferred. In that case the result is 511.5, so the actual output value will be 511 or 512.

19.9 OFFSET CALIBRATION

A relative high offset caused by a very small dynamic comparator (up to 20 mV, so approximately 20 LSB).

This offset can be cancelled with the chopping function, but it still causes unwanted saturation effects at zero scale or full scale. With the GP_ADC_OFFP and GP_ADC_OFFN registers the offset can be compensated in the ADC network itself.

To calibrate the ADC follow the steps in [Table 40](#).

Table 40: GPADC calibration procedure for single-ended and differential modes

Step	Single-ended mode (GP_ADC_SE = 1)	Differential mode (GP_ADC_SE = 0)
1	Set GP_ADC_OFFP = GP_ADC_OFFN = 0x200; GP_ADC_MUTE = 0x1; GP_ADC_SIGN = 0x0	Set GP_ADC_OFFP = GP_ADC_OFFN = 0x200; GP_ADC_MUTE = 0x1; GP_ADC_SIGN = 0x0
2	Start conversion	Start conversion
3	$adc_off_p = GP_ADC_RESULT - 0x200$	$adc_off_p = GP_ADC_RESULT - 0x200$
4	Set GP_ADC_SIGN = 0x1	Set GP_ADC_SIGN = 0x1
5	Start conversion	Start conversion
6	$adc_off_n = GP_ADC_RESULT - 0x200$	$adc_off_n = GP_ADC_RESULT - 0x200$
7	GP_ADC_OFFP = $0x200 - 2 * adc_off_p$ GP_ADC_OFFN = $0x200 - 2 * adc_off_n$	GP_ADC_OFFP = $0x200 - adc_off_p$ GP_ADC_OFFN = $0x200 - adc_off_n$

Note: The average of GP_ADC_OFFP and GP_ADC_OFFN should be 0x200 (with a margin of 20 LSB)

It is recommended to implement the above calibration routine during the initialization phase of the DA14681. To verify the calibration results, check whether the GP_ADC_RESULT value is close to 0x200 while bit GP_ADC_MUTE = 1.

19.10 ZERO-SCALE ADJUSTMENT

The GP_ADC_OFFP and GP_ADC_OFFN registers can also be used to set the zero-scale or full-scale input level at a certain target value. For instance, they can be used to calibrate GP_ADC_RESULT to 0x000 at an input voltage of exactly 0.0 V, or to calibrate the zero scale of a sensor.

19.11 COMMON MODE ADJUSTMENT

The common mode level of the differential signal must be 0.6 V (or 1.8 V with GP_ADC_ATTN3X = 1). If the common mode input level of 0.6 V cannot be achieved, the common mode level of the GP_ADC can be adjusted (the GP_ADC can tolerate a common mode

margin up to 50 mV) according to [Table 41](#).

Table 41: Common Mode adjustment

CM Voltage (V _{ccm})	GP_ADC_OFFP = GP_ADC_OFFN
0.3 V	0x300
0.6 V	0x200
0.9 V	0x100

Any other common mode level between 0.0 V and 1.2 V can be calculated from the table above. Offset calibration can be combined with common mode adjustment by replacing the "0x200" value in the offset calibration routine by the value required to get the appropriate common mode level.

Note: The input voltage limits for the ADC in differential mode are: -1.3 V to +1.3 V (for GP_ADC_ATTN3X = 0,

see Table 36). The differential input range of the ADC is: $-1.2\text{ V} < V[\text{P0}_0, \text{P0}_1] < +1.2\text{ V}$. Therefore, if $V_{\text{cm}} < 0.5\text{ V}$ or $V_{\text{cm}} > 0.7\text{ V}$, the input can no longer cover the whole ADC range.

19.12 INPUT IMPEDANCE, INDUCTANCE AND INPUT SETTLING

The GPADC has no input buffer stage. During sampling phase a capacitor of 1 pF (0.5 pF in differential) is switched to the input line. The pre-charge of this capacitor is at mid-scale level so the input impedance is infinite.

At 100 ksample/s, zero or full-scale single-ended input signal, this sampling capacitor will load the input with:
 $I_{\text{LOAD}} = V * C * f_{\text{S}} = \pm 0.6\text{ V} * 1\text{ pF} * 100\text{ kHz} = \pm 60\text{ nA}$
 (differential: $\pm 1.2\text{ V} * 0.5\text{ pF} * 100\text{ kHz} = \pm 60\text{ nA}$ at both pins).

During sampling phase a certain settling time is required. A 10-bit accuracy requires at least 7 time constants of the output impedance of the input signal source and the 1 pF sampling capacitor. The conversion time is approximately one clock cycle of 16 MHz (62.5 ns).

$$7 * R_{\text{OUT}} * 1\text{ pF} - 62.5\text{ ns} < 1/f_{\text{S}}$$

$$\Rightarrow R_{\text{OUT}} < (1 + 62.5\text{ ns} * f_{\text{S}}) / (7 * 1\text{ pF} * f_{\text{S}})$$

Examples:

$$R_{\text{OUT}} < 8.9\text{ M}\Omega \text{ at } f_{\text{S}} = 100\text{ kHz}$$

$$R_{\text{OUT}} < 890\text{ k}\Omega \text{ at } f_{\text{S}} = 1\text{ MHz}$$

The inductance from the signal source to the ADC input pin must be very small. Otherwise, filter capacitors are required from the input pins to ground (differential mode: from pin to pin).

To observe the noise level of the ADC and the voltage regulator, bit GP_ADC_CTRL_REG[GP_ADC_MUTE] must be set to '1'. The noise should be less than ± 1 LSB on average, with occasionally a ± 2 LSB peak value. If a higher noise level is observed on the input channel(s), applying filter capacitor(s) will reduce the noise.

The 3x input attenuator is realized with a resistor divider network. When bit GP_ADC_CTRL_REG2[GP_ADC_ATTN3X] is set to '1', the input impedance of the selected ADC input channel becomes 300 k Ω (typical) instead of infinite.

Bluetooth Low Energy

20 Sample rate Converter (SRC)

The SRC is a HW accelerator used to convert the sample rate of audio samples between various interfaces. Its primary purpose is to directly connect PCM and PDM channels while converting the rate accordingly. It can provide up or down sampled streams to other interfaces like USB by means of the AMBA bus.

Features

- Supported conversions:
 - SRC_IN (24 bits) to SRC_OUT (24 bits)
 - PDM_IN (1bit) to SRC_OUT (24 bits)
 - SRC_IN (24 bits) to PDM_OUT (1 bit)
- SRC_IN, SRC_OUT Sample rates 62.5 kHz to 16 MHz
- SNR > 100 dB
- Single Buffer I/O with DMA support
- Automatic mode to adjust sample rate to the applied frame sync (e.g. PCM_FSC)
- Manual mode to generate interrupts at the programmed sample rate. Adjustment is done by SW based on buffer pointers drift (e.g for USB)
- SRC runs at 16 MHz

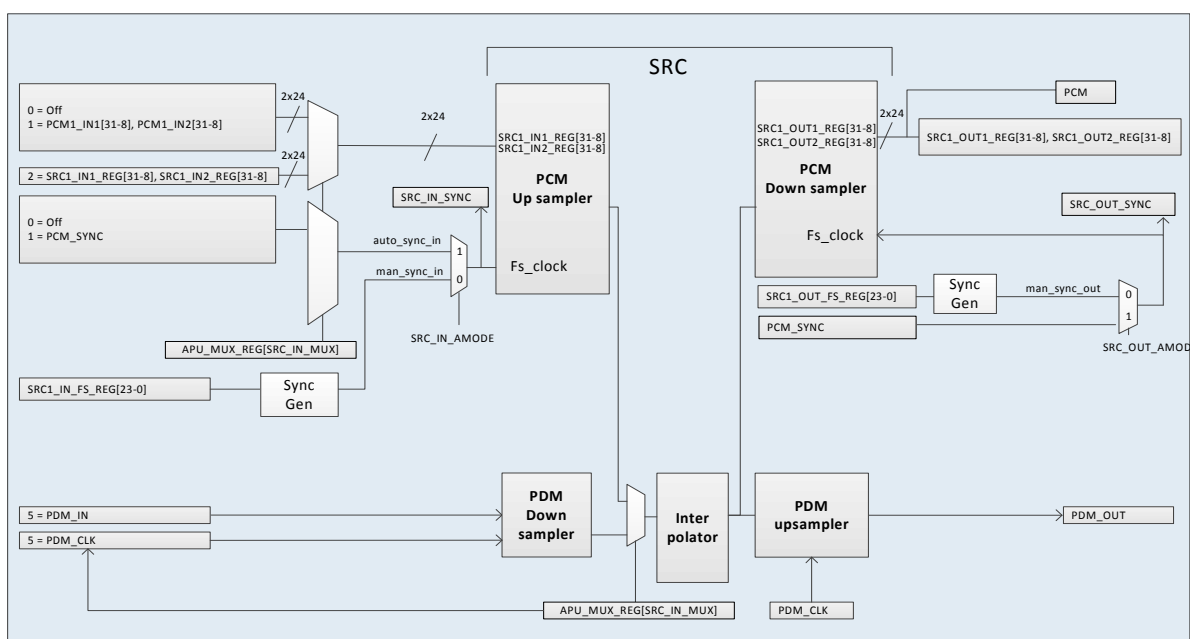

Figure 56: Sample rate Converter block diagram

20.1 ARCHITECTURE

20.1.1 I/O channels

The SRC block converts two 24 bits channels either as a stereo pair or as two mono channels. The PCM linear data pairs are received on SRC_IN and the output is 2x24 bits left aligned on SRC_OUT. The two 1 bit PDM data inputs are received on PDM_IN and are converted to 2x24 bits, left aligned to SRC_OUT or PDM_OUT.

20.1.2 I/O multiplexers

The SRCx_IN input multiplexer (see Figure 56) is controlled by APU_MUX_REG. The input of these multiplexers either come from the audio interfaces or from registers SRC_IN1_REG and SRC_IN2_REG. The data to these register is left aligned, bits 31-8 are mapped on bits 23-0 of the SRC.

The 24 bits SRCs outputs can be read in SRC_OUT1_REG and SRC_OUT2_REG and is also routed to the PCM. This input selection of these multiplexers is also controlled by APU_MUX_REG.

20.1.3 Input and Output Sample rate conversion

The SRC has a sample rate converter on the input and one at the output. Depending on the use case the converters operate in either manual or automatic conversion mode. This mode can be set in the SRC_CTRL_REG bits SRC_IN_AMODE and bit SRC_OUT_AMODE.

20.1.4 SRC conversion modes of operation

The SRC can operate in two mode of operation:

- Manual mode
- Automatic mode

In **manual mode** the sample rate to convert to is determined by the values in the SRC_IN_FS_REG, SRC_OUT_FS_REG.

Manual mode is used for sample rate conversion to/from the e.g. USB. The CPU compares the buffer pointers of the USB transmit buffers with the e.g PDM receive buffer pointers. If the pointers drift, the PDM sample rate is adjusted in the SRC_OUT_FS_REG. Hence, in the SRC_OUT_SYNC interrupt service routine, the PDM samples are read.

In **automatic mode**, the sample rate is adjusted according to the rate at which the samples are read from, or written to the SRC. For instance, if PCM slave data is transmitted to USB, PCM_IN is selected in the SRC_IN_MUX. The SRC_IN is set to automatic mode to convert sample receive at PCM_FSC rate. The SRC_OUT is also set to automatic mode. In the SRC_OUT_SYNC interrupt service routine, the PCM samples are read and the rate is determined by the main counter MAIN_CNT (8-192kHz)

Typical use cases of the SRC are given in Table 42.

20.1.5 DMA operation

If more than one sample must be transfer to/from the CPU or the sample rate is so high that it interrupt the CPU too often, the DMA controller must be engaged to perform the transactions.

20.1.6 Interrupts

After a Sample Rate conversion the input upsampler and output down sampler generate edge triggered interrupts on SRC_IN_SYNC and SRC_OUT_SYNC to the CPU which do not have to be cleared. Note that only one sample shall be read from or written to a single register at a time (i.e. there are no FIFOs included).

20.1.7 SRC use cases

Table 42 shows typical use cases of the Sample Rate Converter.

Table 42: Typical SRC use cases

Use case	SRCx_IN_AMODE DATA path SRCx_IN_SYNC	SRCx_IN_SYNC (out)	SRCx_OUT_AMODE DATA path SRCx_OUT_SYNC	SRCx_OUT_SYNC (out)
PCM_IN to USB	Automatic PCMx_IN_DATA PCMx_SYNC	-	Manual SRCx_OUT_REG	up-to 192kHz
PDM_IN to USB	Automatic PDMx_IN_DATA PCMx_SYNC	-	Manual SRCx_OUT_REG	up-to 192kHz
SPDIF_IN to USB	Automatic SPDIF_IN_DATA SPDIF_IN_SYNC	-	Manual SRCx_OUT_REG	48kHz (TYP) (ISR adjusts FS)
USB to PCM_OUT	Manual SRCx_IN_REG	up-to 192kHz	Automatic SRCx_OUT_REG PCMx_FSC (output)	up-to 192kHz
PCM to PCM resampler (output must be a multiple of 8 kHz)				
PCM1_IN to PCM2_OUT	Automatic PCM1_IN PCM1_FSC (input)		Automatic PCM2_OUT PCM2_FSC (output)	-
PCM2_IN to PCM1_OUT	Automatic PCM2_IN PCM2_FSC (input)		Automatic PCM1_IN PCM1_FSC (output)	-

21 PDM interface

The Pulse Density Modulation (PDM) interface provides a serial connection for up-to 2 input devices (e.g MEMS microphones) or output devices. The interfaces have a common clock PDM_CLK and one input PDM_DI which is capable of carrying two channels. Figure 57 shows a typical connection of two microphone sharing one data line.

The PDM input data is a 1-bit data and is encoded so that the left channel is clocked in on the falling edge of PDM_CLK and the right channel is clocked in on the rising edge of PDM_CLK as shown in Figure 58.

The 1 bits data stream is downsampled to 24 bits PCM samples in the HW Sample Rate converter (SRC) for further processing in the DSP.

The interface supports MEMS microphone sleep mode by disabling the PDM_CLK.

The PDM interface signals are available through the PPA multiplexer. The interface levels are determined by the IO group on which the PDM signals are mapped which can be hard wired to 1.8 V and 3.3 V.

Features

- PDM_CLK output frequency
62.5 kHz - 4 MHz
- Downsampling to 24 bits in SRC
- PDM_CLK on/off to support Sleep mode
- PDM_IN: 1 Channel in stereo format
- PDM_OUT: 2 Channels in mono format,
1 Channels in stereo format
- Programmable Left/Right channel selection

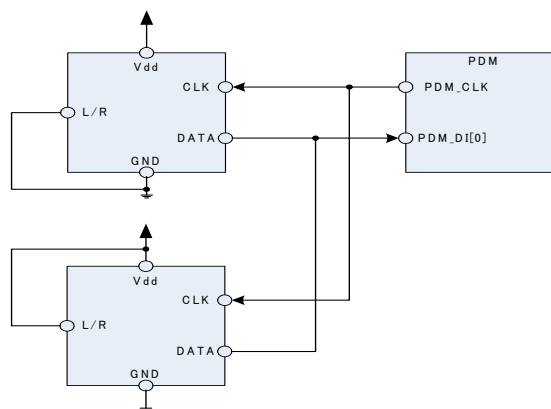

Figure 57: PDM with dual mic interface

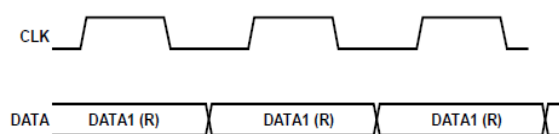

Figure 9. Mono PDM Format

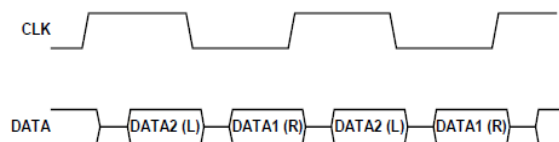

Figure 10. Stereo PDM Format

Figure 58: PDM formats

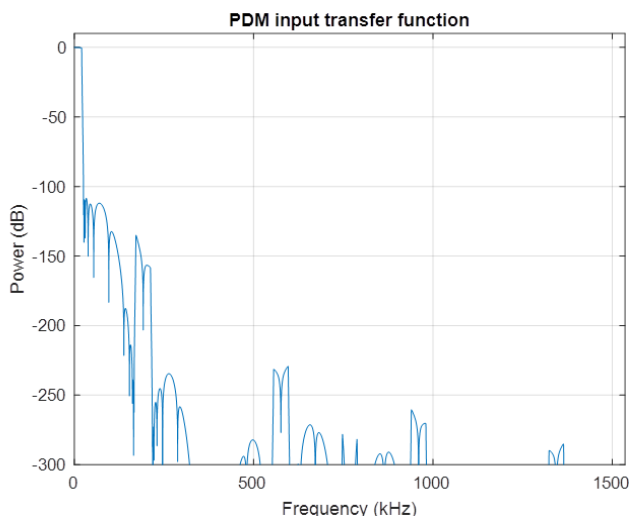

Figure 59: SRC PDM input transfer function

22 PCM Controller

The PCM controller is implementing an up-to 192kHz synchronous interface to external audio devices, ISDN circuits and serial data interfaces.

It is accessed through the APB32 interface. PCM can individually operate in master or slave mode. In slave mode, the phase between the external and internal frame sync can be measured and used to compensate for drift.

The data IO registers have DMA support in order to reduce the interrupt overhead to the CPU. Up-to 8 channels of 8 bits with a programmable delay are supported in received and transmit direction.

The controller supports PCM, I2S, TDM and IOM2 formats.

Features

- PCM_CLK Master/slave
- PCM_FSC

- Master/slave 4 kHz to 96 kHz
- Strobe Length 1, 8, 16, 24, 32, 40, 48 and 64 bits
- PCM_FSC before or on the first bit. (In Master mode)
- 2x32 channels
- Programmable slot delay up-to 31*8bits
- Formats
 - PCM mode
 - I2S mode (Left/Right channel selection) with N*8 for Left and N*8 for Right
 - IOM2 mode (double clock per bit)
- Programmable clock and frame sync inversion
- Direct connection to Sample Rate Converter (SRC)
- Interrupt line to the CPU
- DMA support

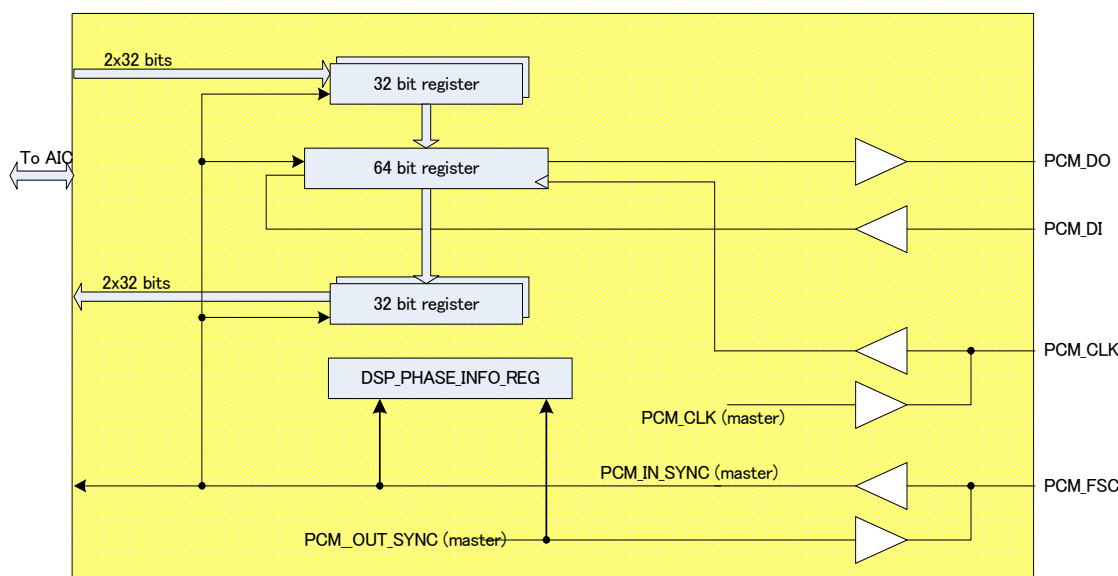

Figure 60: PCM Controller

22.1 ARCHITECTURE

22.1.1 Interface Signals.

- PCM_FSC, strobe signal input, output. Supports 8/16/32/48/96/128/192kHz. Can generate an interrupt to the CPU.
- PCM_CLK, PCM clock input, output.
- PCM_DO, PCM Data output, push pull or open drain with external pull-up resistor.
- PCM_DI, PCM Data input.

PCM interface can be powered down by the `PCM_CTRL_REG[PCM_EN] = 0`.

22.1.2 Channel ACCESS

The PCM interface has two 32-bit channels for TX and RX. Channels are accessed through 32 bits registers: `PCM1/2_OUT1_REG`, `PCM1/2_OUT2_REG`, `PCM1/2_IN1_REG` and `PCM1/2_IN2_REG`.

The registers are only word-wise (32 bits) accessible by the CPU or the DMA via the APB-32 bridge. The 32 bits registers are arranged as 8 channels of 8 bits, named channel 1 to channel 8.

By a flexible clock inversion, channel delay and strobe length adjustment various format like PCM, I2S, TDM and IOM2 can be made

22.1.3 Channel delay

The 8 PCM channels can be delayed with a maximum delay of 31x8bits using the bit field PCM_x_CTRL_REG[PCM_CH_DEL]. Note that a high delay count in combination with a slow clock, can lead to the PCM_x_FSC sync occurring before all channels are shifted in or out. The received bits of the current channel may not be properly aligned in that case.

22.1.4 Clock generation

Figure 61 shows the PCM clock generation block and Figure 62 the PCM_CLK_DIV value for given PCM_FSC and PCM_CLK in master mode. PCM_CLK_DIV is only 10 bits. For a higher division value, use either DIV1 or DIVN must be selected.

The PCM_CLK_DIV calculation shows the following

use cases, with 16 bits, 32 bits, 48 bits, 64 bits.

The PCM_FSC will be synchronised to the main counter if PCM_MAIN_SYNC is '1'.

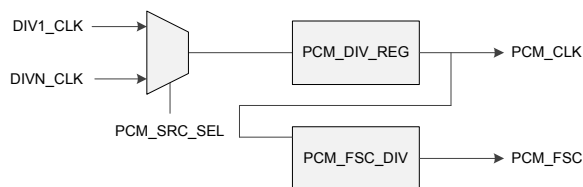

Figure 61: PCM clock generation

			XTAL			PLL		
			16000			96000		
sample rate	bits	desired bitclock khz	desired divider	actual divider	actual wordsize	desired divider	actual divider	actual wordsize
8	1*8	64	250	250	8	1500	1500	8
8	1*16	128	125	125	16	750	750	16
8	1*24	192	83.33333	80	25	500	500	24
8	1*32	256	62.5	50	40	375	375	32
8	2*8	128	125	125	8	750	750	8
8	2*16	256	62.5	50	20	375	375	16
8	2*24	384	41.66667	40	25	250	250	24
8	2*32	512	31.25	25	40	187.5	150	40
16	1*8	128	125	125	8	750	750	8
16	1*16	256	62.5	50	20	375	375	16
16	1*24	384	41.66667	40	25	250	250	24
16	1*32	512	31.25	25	40	187.5	150	40
16	2*8	256	62.5	50	10	375	375	8
16	2*16	512	31.25	25	20	187.5	150	20
16	2*24	768	20.83333	20	25	125	125	24
16	2*32	1024	15.625	10	50	93.75	75	40
32	1*8	256	62.5	50	10	375	375	8
32	1*16	512	31.25	25	20	187.5	150	20
32	1*24	768	20.83333	20	25	125	125	24
32	1*32	1024	15.625	10	50	93.75	75	40
32	2*8	512	31.25	25	10	187.5	150	10
32	2*16	1024	15.625	10	25	93.75	75	20
32	2*24	1536	10.41667	10	25	62.5	50	30
32	2*32	2048	7.8125	5	50	46.875	25	60
48	1*8	384	41.66667	N/A	N/A	250	250	8
48	1*16	768	20.83333	N/A	N/A	125	125	16
48	1*24	1152	13.88889	N/A	N/A	83.33333	80	25
48	1*32	1536	10.41667	N/A	N/A	62.5	50	40
48	2*8	768	20.83333	N/A	N/A	125	125	8
48	2*16	1536	10.41667	N/A	N/A	62.5	50	20
48	2*24	2304	6.94444	N/A	N/A	41.66667	40	25
48	2*32	3072	5.208333	N/A	N/A	31.25	25	40

Figure 62: Integer PCM_CLK_DIV values for given PLL_MAIN frequencies and sample rates

Note, that in the yellow colored cases, PCM_FSC cannot be 50% duty cycle while using the integer option for generating the PCM_CLK. However, this is feasible if

the fractional option is used (see PCM_DIV_REG and PCM_FDIV_REG).

22.1.5 DATA FORMATS

22.1.5.1 PCM master mode

Master mode is selected if PCM_CTRL_REG[MAS-TER] = 1.

In master mode PCM_FSC is output and falls always over Channel 0. The duration of PCM_FSC is programmable with PCMx_CTRL_REG[PCM_FSCLEN]= 1 or 8,16, 24, 32 clock pulses high. The start position is programmable with PCM_CTRL_REG[PCM_FSCDEL] and can be placed before or on the first bit of channel 0. The repetition frequency of PCM_FSC is programmable in PCMx_CTRL_REG[PCM_FSC_DIV] to from 8-192kHz.

If master mode selected, PCM_CLK is output and provides one or two clocks per data bit programmable in PCM_CTRL_REG[PCM_CLK_BIT].

The polarity of the signal can be inverted with bit

PCM_CTRL_REG[PCM_CLKINV].

The PCM_CLK frequency selection is described in section 22.1.4.

22.1.5.2 PCM Slave mode

In slave mode (bit MASTER = 0) PCM_FSC is input and determines the starting point of channel 0. The repetition rate of PCM_FSC must be equal to PCM_SYNC and must be high for at least one PCM_CLK cycle. Within one frame, PCM_FSC must be low for at least PCM_CLK cycle. Bit PCM_FSCDEL sets the start position of PCM_FSC before or on the first bit (MSB).

In slave mode PCM_CLK is input. The minimum received frequency is 256 kHz, the maximum is 12.288 MHz.

In slave mode the main counter can be stopped and resumed on a PCM1_FSC or PCM2_FSC rising edge. T

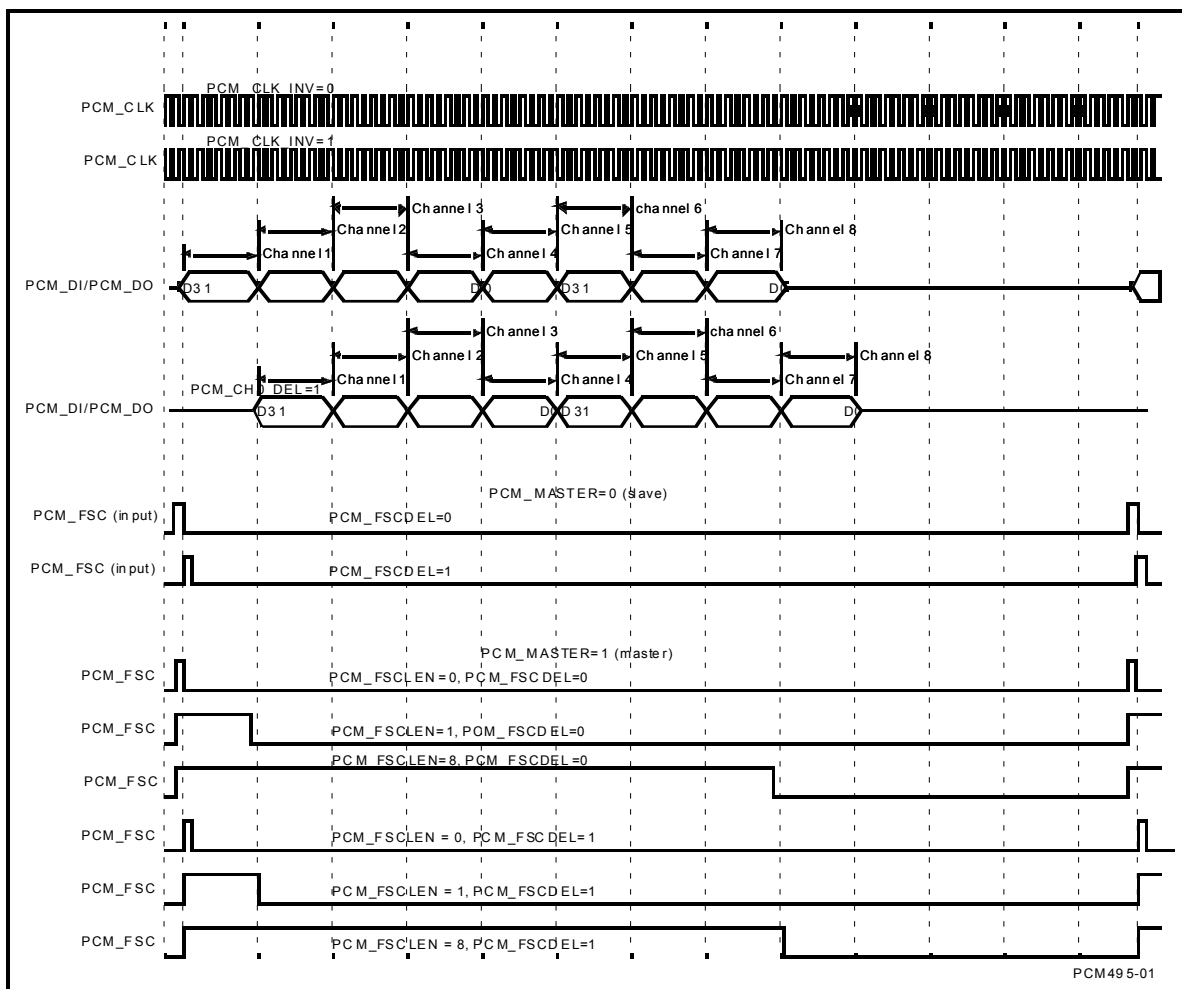

Figure 63: PCM interface formats

22.1.5.3 I2S formats

The digital audio interface supports I2S mode, Left Justified mode, Right Justified mode and TDM mode.

I2S mode

To support I2S mode, the MSB of the right channel is valid on the second rising edge of the bit clock after the rising edge of the PCM_FSC, and the MSB of the left channel is valid on the second rising edge of the bit clock after the falling edge of the PCM_FSC.

Settings for I2S mode:

- PCM_FSC_EDGE: 1 (all after PCM_FSC)
- PCM_FSCLLEN: 4 (4x8 High, 4x8 Low)
- PCM_FSC_DEL: 0 (one bit delayed)

- PCM_CLK_INV: 1 (output on falling edge)
- PCM_CH0_DEL: 0 (no channel delay)

TDM mode

A time is specified from the normal 'start of frame' condition using register bits PCM_CH0_DEL. In the left justified TDM example illustrated in Figure 65, the left channel data is valid PCM_CH0_DEL clock cycles after the rising edge of the PCM_FSC, and the right channel data is valid the same PCM_CH0_DEL number of clock cycles after the falling edge of the PCM_FSC.

By delaying the channels, also left and right alignment can be achieved.

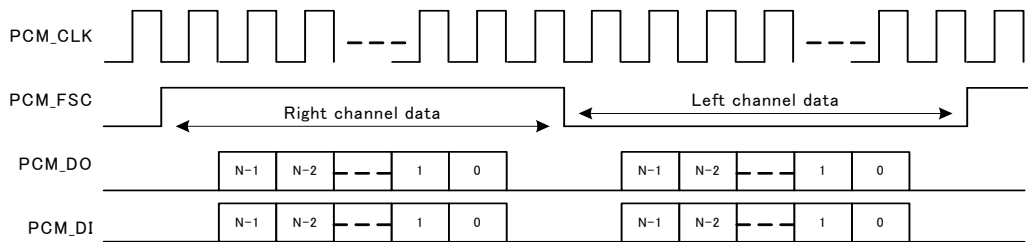

Figure 64: I2S Mode

Settings for TDM mode:

- PCM_FSC_EDGE: 1 (rising and falling PCM_FSC)
- PCM_FSCLLEN: Master 1 to 4
Slave waiting for edge.
- PCM_FSC_DEL: 1 (no bit delay)

- PCM_CLK_INV: 1 (output on falling edge)
- PCM_CH0_DEL: Slave 0-31 (channel delay)
Master 1-3

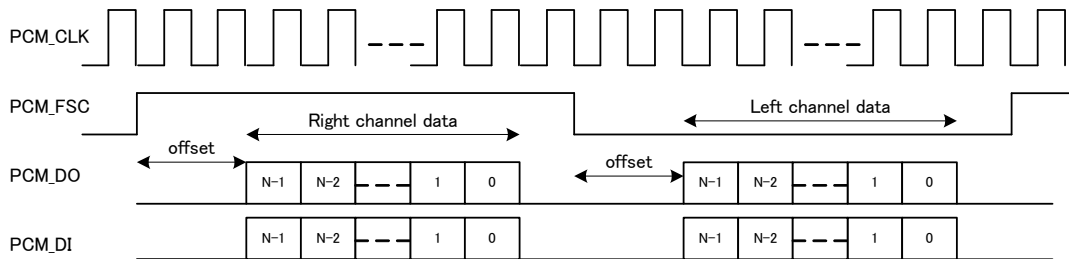

Figure 65: I2S TDM mode (left justified mode)

22.1.6 IOM mode

In the IOM format, the PCM_CLK frequency is twice the data bit cell duration. In slave mode synchronization is on the first rising edge of PCM_FSC while data is clock in on the second falling edge.

Settings for IOM mode:

- PCM_FSC_EDGE: 0 (rising edge PCM_FSC)
- PCM_FSCLLEN: 0 (one cycle)

- PCM_FSC_DEL: 0 (no bit delay)
- PCM_CLK_INV: 0 (output on rising edge)
- PCM_CH0_DEL: 0 (no delay)
- PCM_CLK_BIT: 1

22.1.7 External synchronisation

With the PCM interface in slave mode, the PCM interface supports direct routing through the sample rate convertor (SRC). Any drift in PCM_FSC or other frame

sync frequencies like 44.1 kHz can be directly resampled to e.g 48kHz internal sample rate.

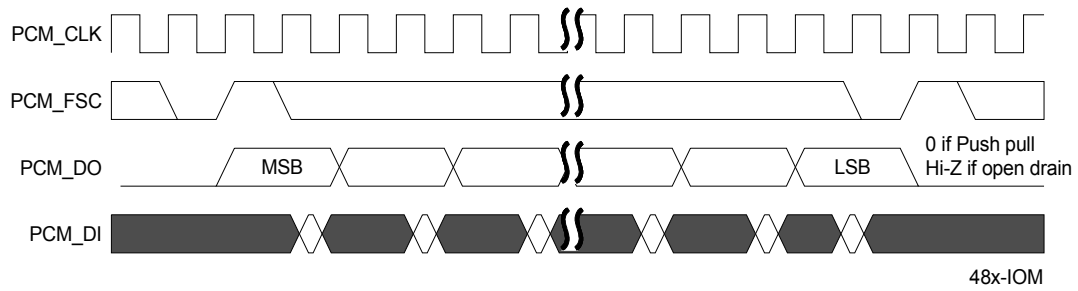

Figure 66: IOM format

23 UART

The DA14681 contains two instances of this block, i.e. UART and UART2.

The UART is compliant to the industry-standard 16550 and is used for serial communication with a peripheral, modem (data carrier equipment, DCE) or data set. Data is written from a master (CPU) over the APB bus to the UART and it is converted to serial form and transmitted to the destination device. Serial data is also received by the UART and stored for the master (CPU) to read back.

There is DMA support on both UARTs. UART2 only supports hardware flow control signals (RTS, CTS) and includes a 16-byte FIFO while UART is not.

Features

- 16 bytes Transmit and receive FIFOs. (UART2 only)
- Hardware flow control support (CTS/RTS) (UART2 only)

- Shadow registers to reduce software overhead and also include a software programmable reset
- Transmitter Holding Register Empty (THRE) interrupt mode
- IrDA 1.0 SIR mode supporting low power mode.
- Functionality based on the 16550 industry standard:
- Programmable character properties, such as number of data bits per character (5-8), optional
- parity bit (with odd or even select) and number of stop bits (1, 1.5 or 2)
- Line break generation and detection
- Prioritized interrupt identification
- Programmable serial data baud rate as calculated by the following: $\text{baud rate} = (\text{serial clock frequency}) / (\text{divisor})$.

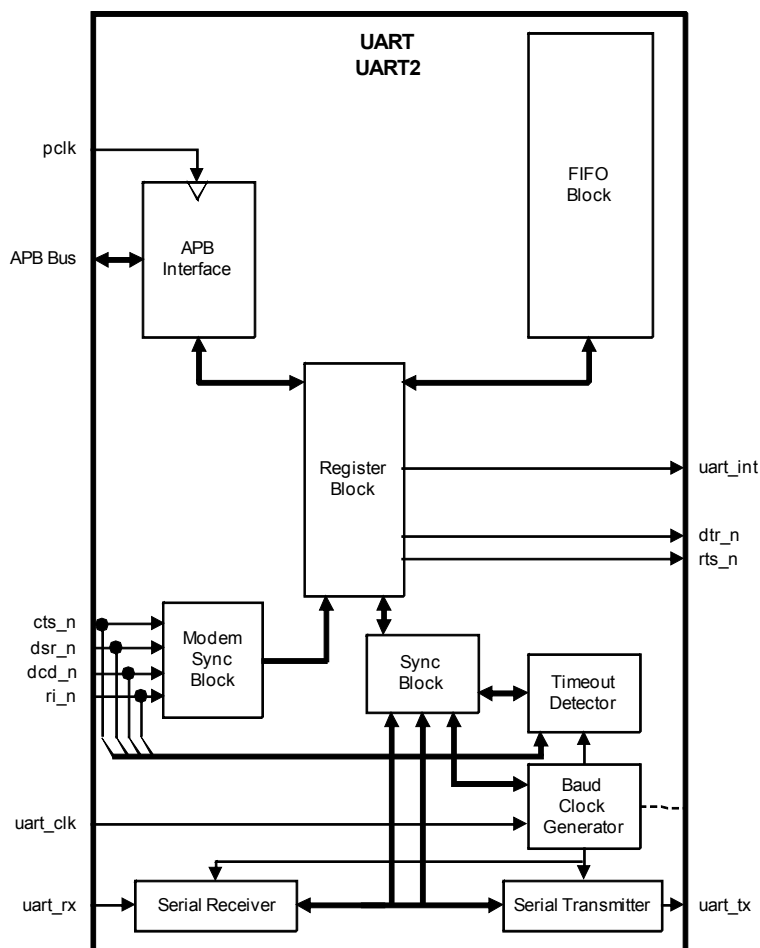

Figure 67: UART Blockdiagram

23.1 UART (RS232) SERIAL PROTOCOL

Because the serial communication between the UART and the selected device is asynchronous, additional bits (start and stop) are added to the serial data to indicate the beginning and end. Utilizing these bits allows

two devices to be synchronized. This structure of serial data accompanied by start and stop bits is referred to as a character, as shown in Figure 68.

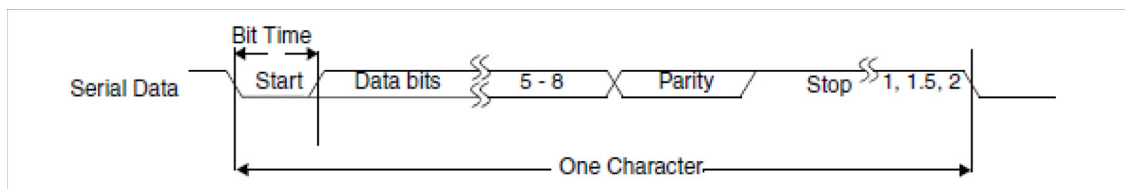

Figure 68: Serial Data Format

An additional parity bit may be added to the serial character. This bit appears after the last data bit and before the stop bit(s) in the character structure to provide the UART with the ability to perform simple error checking on the received data.

The UART Line Control Register (UART_LCR_REG) is used to control the serial character characteristics. The individual bits of the data word are sent after the start bit, starting with the least-significant bit (LSB). These are followed by the optional parity bit, followed by the stop bit(s), which can be 1, 1.5 or 2.

ted for exactly the same time duration. This is referred to as a Bit Period or Bit Time. One BitTime equals 16 baud clocks. To ensure stability on the line the receiver samples the serial input data at approximately the mid point of the Bit Time once the start bit has been detected. As the exact number of baud clocks that each bit was transmitted for is known, calculating the mid point for sampling is not difficult, that is every 16 baud clocks after the mid point sample of the start bit. Figure 69: shows the sampling points of the first couple of bits in a serial character.

All the bits in the transmission (with exception to the half stop bit when 1.5 stop bits are used) are transmit-

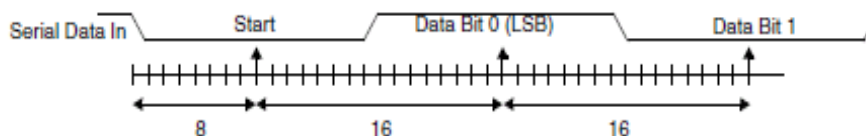

Figure 69: Receiver Serial Data Sample Points

As part of the 16550 standard an optional baud clock reference output signal (baudout_n) is supplied to provide timing information to receiving devices that require it. The baud rate of the UART is controlled by the serial clock (sclk or pclk in a single clock implementation) and

the Divisor Latch Register (DLH and DLL). The available baud rates are presented in the following table:

Table 43: Baud rate generation

Baud Rate	Divider	DLH/DLL Reg	UART_DLF Reg	Error %
9600	104.166	104	3	0.01
19200	52.083	52	1	0.04
38400	26.041	26	1	0.07
57600	17.361	17	6	0.07
115200	8.680	8	11	0.07
230400	4.340	4	5	0.64
812500	1.230	1	4	1.53
1000000	1	1	0	0

23.2 IRDA 1.0 SIR PROTOCOL

The Infrared Data Association (IrDA) 1.0 Serial Infrared (SIR) mode supports bi-directional data communications with remote devices using infrared radiation as the transmission medium. IrDA 1.0 SIR mode specifies a maximum baud rate of 115.2 kBaud.

Note 4: Attention. Information provided on IrDA SIR mode in this section assumes that the reader is fully familiar with the IrDA Serial Infrared Physical Layer Specifications. This specification can be obtained from the following website:
<http://www.irda.org>

The data format is similar to the standard serial (sout and sin) data format. Each data character is sent serially, beginning with a start bit, followed by 8 data bits, and ending with at least one stop bit. Thus, the number of data bits that can be sent is fixed. No parity information can be supplied and only one stop bit is used while in this mode.

Trying to adjust the number of data bits sent or enable parity with the Line Control Register (LCR) has no

effect. When the UART is configured to support IrDA 1.0 SIR it can be enabled with Mode Control Register (MCR) bit 6. When the UART is not configured to support IrDA SIR mode, none of the logic is implemented and the mode cannot be activated, reducing total gate counts. When SIR mode is enabled and active, serial data is transmitted and received on the sir_out_n and sir_in ports, respectively.

Transmitting a single infrared pulse signals a logic zero, while a logic one is represented by not sending a pulse. The width of each pulse is 3/16ths of a normal serial bit time. Thus, each new character begins with an infrared pulse for the start bit. However, received data is inverted from transmitted data due to the infrared pulses energizing the photo transistor base of the IrDA receiver, pulling its output low. This inverted transistor output is then fed to the UART sir_in port, which then has correct UART polarity. Figure 70: shows the timing diagram for the IrDA SIR data format in comparison to the standard serial format.

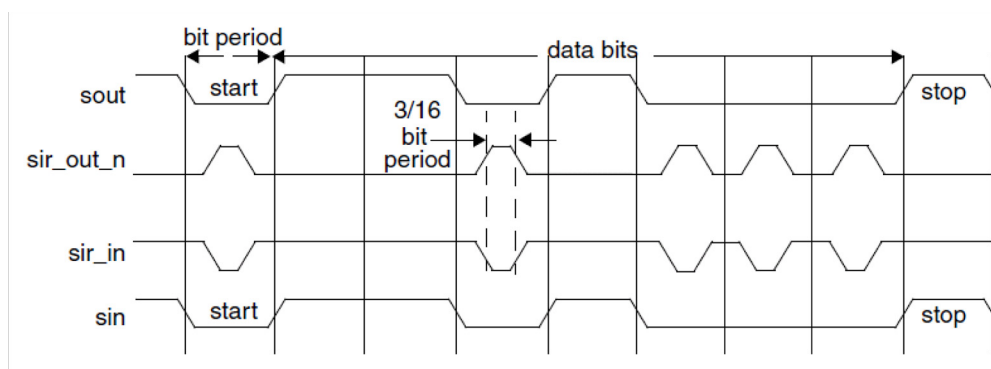

Figure 70: IrDA SIR Data Format

As detailed in the IrDA 1.0 SIR, the UART can be configured to support a low-power reception mode. When the UART is configured in this mode, the reception of SIR pulses of 1.41 microseconds (minimum pulse duration) is possible, as well as nominal 3/16 of a normal serial bit time. Using this low-power reception mode requires programming the Low Power Divisor Latch (LPDLL/LPDLH) registers. It should be noted that for all sclk frequencies greater than or equal to 7.37MHz (and obey the requirements of the Low Power Divisor Latch registers), pulses of 1.41uS are detectable. However there are several values of sclk that do not allow the detection of such a narrow pulse and these are as follows:

Table 44: Low power Divisor Latch register values

SCLK	Low power Divisor Latch register value	Min Pulse width for detection
1.84 MHz	1	3.77 μ S
3.69 MHz	2	2.086 μ S

Table 44: Low power Divisor Latch register values

SCLK	Low power Divisor Latch register value	Min Pulse width for detection
5.33 MHz	3	1.584 μ S

When IrDA SIR mode is enabled, the UART operation is similar to when the mode is disabled, with one exception; data transfers can only occur in half-duplex fashion when IrDA SIR mode is enabled. This is because the IrDA SIR physical layer specifies a minimum of 10ms delay between transmission and reception. This 10ms delay must be generated by software.

23.3 CLOCK SUPPORT

The UART has two system clocks (pclk and sclk). Having the second asynchronous serial clock (sclk) implemented accommodates accurate serial baud rate settings, as well as APB bus interface requirements.

With the two clock design a synchronization module is implemented for synchronization of all control and data

across the two system clock boundaries.

A serial clock faster than four-times the PCLK does not leave enough time for a complete incoming character to be received and pushed into the receiver FIFO. However, in most cases, the PCLK signal is faster than the serial clock and this should never be an issue.

The serial clock modules must have time to see new register values and reset their respective state machines. This total time is guaranteed to be no more than eight clock cycles of the slower of the two system clocks. Therefore, no data should be transmitted or received before this maximum time expires, after initial configuration.

23.4 INTERRUPTS

Table 45: UART Interrupt priorities

Interrupt Id	Interrupt Set and Reset Functions			
Bits [3-0]	Priority Level	Interrupt Type	Interrupt Source	Interrupt Reset Control
0001	-	None		
0110	Highest	Receiver Line status	Overrun/parity/ framing errors or break interrupt	Reading the line status register
0100	1	Receiver Data Available	Receiver data available (non-FIFO mode or FIFOs disabled) or RCVR FIFO trigger level reached (FIFO mode and FIFOs enabled)	Reading the receiver buffer register (non-FIFO mode or FIFOs disabled) or the FIFO drops below the trigger level (FIFO mode and FIFOs enabled)
1100	2	Character timeout indication	No characters in or out of the RCVR FIFO during the last 4 character times and there is at least 1 character in it during this time.	Reading the receiver buffer register
0010	3	Transmitter holding register empty	Transmitter holding register empty (Prog. THRE Mode disabled) or XMIT FIFO at or below threshold (Prog. THRE Mode enabled).	Reading the IIR register (if source of interrupt); or, writing into THR (FIFOs or THRE Mode not selected or disabled) or XMIT FIFO above threshold (FIFOs and THRE Mode selected and enabled).
0000	4	Reserved		
0111	Lowest	Reserved	-	-

23.5 PROGRAMMABLE THRE INTERRUPT

The UART can be configured to have a Programmable THRE Interrupt mode available to increase system performance.

When Programmable THRE Interrupt mode is selected it can be enabled via the Interrupt Enable Register (IER[7]). When FIFOs and the THRE Mode are implemented and enabled, THRE Interrupts are active at, and below, a programmed transmitter FIFO empty threshold level, as opposed to empty, as shown in the flowchart in [Figure 71](#).

The assertion of the UART interrupt (UART_INT) occurs whenever one of the several prioritized interrupt types are enabled and active. The following interrupt types can be enabled with the IER register:

- Receiver Error
- Receiver Data Available
- Character Timeout (in FIFO mode only)
- Transmitter Holding Register Empty at/below threshold (in Programmable THRE interrupt mode)

When an interrupt occurs the master accesses the UART_IIR_REG to determine the source of the interrupt before dealing with it accordingly. These interrupt types are described in more detail in [Table 45](#)

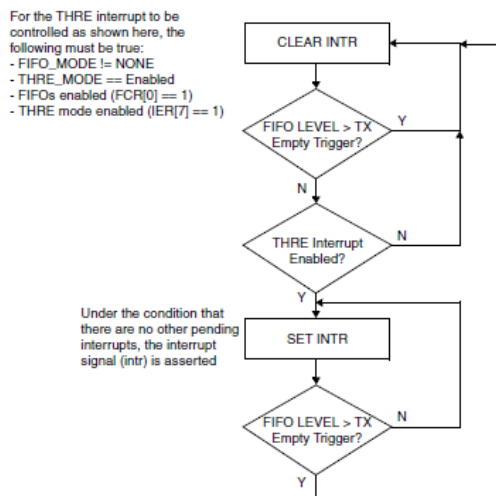

Figure 71: Flowchart of Interrupt Generation for Programmable THRE Interrupt Mode

This threshold level is programmed into FCR[5:4]. The available empty thresholds are: empty, 2, ¼ and ½. See UART_FCR_REG for threshold setting details. Selection of the best threshold value depends on the system's ability to begin a new transmission sequence in a timely manner. However, one of these thresholds should prove optimum in increasing system performance by preventing the transmitter FIFO from running empty.

In addition to the interrupt change, Line Status Register (LSR[5]) also switches function from indicating transmitter FIFO empty, to FIFO full. This allows software to fill the FIFO each transmit sequence by polling LSR[5] before writing another character. The flow then becomes, "fill transmitter FIFO whenever an interrupt

occurs and there is data to transmit", instead of waiting until the FIFO is completely empty. Waiting until the FIFO is empty causes a performance hit whenever the system is too busy to respond immediately.

Even if everything else is selected and enabled, if the FIFOs are disabled via FCR[0], the Programmable THRE Interrupt mode is also disabled. When not selected or disabled, THRE interrupts and LSR[5] function normally (both reflecting an empty THR or FIFO). The flowchart of THRE interrupt generation when not in programmable THRE interrupt mode is shown in Figure 72.

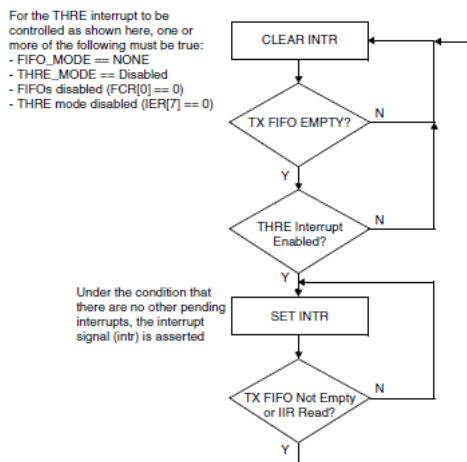

Figure 72: Flowchart of Interrupt generation when not in Programmable THRE Interrupt Mode

23.6 SHADOW REGISTERS

The shadow registers shadow some of the existing register bits that are regularly modified by software. These can be used to reduce the software overhead that is introduced by having to perform read-modify writes.

- UART_SRBR_REG support a host burst mode where the host increments its address but still accesses the same Receive buffer register
- UART_STHR support a host burst mode where the host increments its address but still accesses the same transmit holding register.
- UART_SFE_REG accesses the FCR[0] register without accessing the other UART_FCR_REG bits.
- UART_SRT_REG accesses the FCR[7-6] register without accessing the other UART_FCR_REG bits.
- UART_STER_REG accesses the FCR[5-4] register without accessing the other UART_FCR_REG bits.

23.7 DIRECT TEST MODE

The on-chip UARTS can be used for the Direct Test Mode required for the final product PHY layer testing. It can be done either over the HCI layer, which engages a full CTS/RTS UART or using a 2-wire UART directly as described in the Bluetooth Low Energy Specification (Volume 6, Part F).

24 SPI+ Interface

This interface supports a subset of the Serial Peripheral Interface SPI™. The serial interface can transmit and receive 8, 16 or 32 bits in master/slave mode and transmit 9 bits in master mode. The SPI + interface has enhanced functionality with bidirectional 2x16-bit word FIFOs. Two SPI+ controllers are instantiated in the system i.e. SPI and SPI2.

SPI™ is a trademark of Motorola, Inc.

Features

- Slave and Master mode
- 8-bit, 9-bit, 16-bit or 32-bit operation

- Clock speeds upto 48 MHz for the SPI controller. Programmable output frequencies of SPI interface clock divided by 2, 4, 8 and 14
- SPI mode 0, 1, 2, 3 support. (clock edge and phase)
- Programmable SPI_DO idle level
- Maskable Interrupt generation
- Bus load reduction by unidirectional writes-only and reads-only modes.
- Built-in RX/TX FIFOs for continuous SPI bursts.
- DMA support

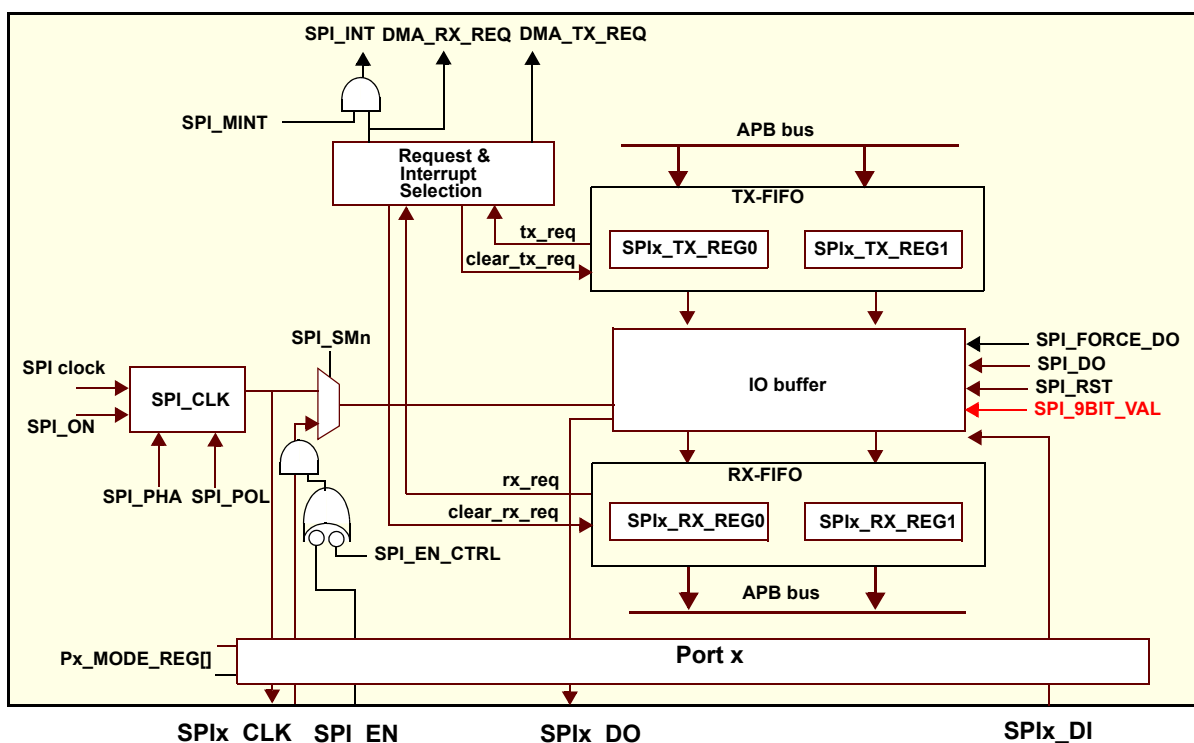

Figure 73: SPI block diagram

24.1 OPERATION WITHOUT FIFOS

This mode is the default mode.

Master mode

To enable SPI™ operation, first the individual port signal must be enabled. Next the SPI must be configured in SPI_CTRL_REG, for the desired mode. Finally bit SPI_ON must be set to 1.

A SPI transfer cycle starts after writing to the SPIx_RX_TX_REG0. In case of 32 bits mode, the SPIx_RX_TX_REG1 must be written first. Writing to SPIx_RX_TX_REG0 also sets the SPI_TXH. As soon as the holding register is copied to the IO buffer, the SPI_TXH is reset and a serial transfer cycle of 8/9/16/32 clock-cycles is started which causes 8/9/16/32 bits

to be transmitted on SPIx_DO. Simultaneously, data is received on SPIx_DI and shifted into the IO buffer. The transfer cycle finishes after the 8th/9th/16th/32nd clock cycle and SPI_INT_BIT bit is set in the SPIx_CTRL_REG and SPI_INT_PENDING bit in (RE)SET_INT_PENDING_REG is set. The received bits in the IO buffer are copied to the SPIx_RX_TX_REG0 (and SPIx_RX_TX_REG1 in case of 32 bits mode) where they can be read by the CPU.

Interrupts to the CPU can be disabled using the SPI_MINT bit. To clear the SPI interrupt source, any value to SPIx_CLEAR_INT_REG must be written. Note however that SPI_INT will be set as long as the RX-FIFO contains unread data.

Slave mode

The slave mode is selected with SPI_SMn set to 1 and the Px_MODE_REG must also select SPIx_CLK as input. The functionality of the IO buffer in slave and master mode is identical. The SPI module clocks data in on SPIx_DI and out on SPIx_DO on every active edge of SPIx_CLK. As shown in [Figure 74](#) to [Figure 77](#). SPI1 has an active low clock enable SPI1_EN which can be enabled with bit SPI_EN_CTRL=1.

In slave mode the internal SPI clock must be more than four times the SPIx_CLK

In slave mode the SPI_EN serves as a clock enable and bit synchronization. If enabled with bit SPI_EN_CTRL. As soon as SPI_EN is deactivated between the MSB and LSB bits, the I/O buffer is reset.

SPI_POL and SPI_PHA

The phase and polarity of the serial clock can be changed with bits SPI_POL and SPI_PHA in the SPIx_CTRL_REG.

SPI_DO idle levels

The idle level of signal SPI_DO depends on the master or slave mode and polarity and phase mode of the clock.

In master mode pin SPIx_DO gets the value of bit SPI_DO if the SPI is idle in all modes. Also if slave in SPI modes 0 and 2, SPI_DO is the initial and final idle level.

In SPI modes 1 and 3 however there is no clock edge after the sampled lsb and pin SPIx_DO gets the lsb value of the IO buffer. If required, the SPIx_DO can be forced to the SPI_DO bit level by resetting the SPI to the idle state by shortly setting bit **SPI_RST** to 1. (Optionally **SPI_FORCE_DO** can be set, but this does not reset the IO buffer). The following diagrams show the timing of the SPI™ interface.

Writes only mode

In “writes only” mode (SPI_FIFO_MODE = “10”) only the TX-FIFO is used. Received data will be copied to the SPIx_RX_TX_REGx, but if a new SPI transfer is finished before the old data is read from the memory, this register will be overwritten.

SPI_INT acts as a tx_request signal, indicating that there is still place in the FIFO. It will be ‘0’ when the FIFO is full or else ‘1’ when it’s not full. This is also indicated in the SPIx_CTRL_REG[SPI_TXH], which is ‘1’ if the TX-FIFO is full. Writing to the FIFO if this bit is still 1, will result in transmission of undefined data. If all data has been transferred, SPIx_CTRL_REG1[SPI_BUSY] will become ‘0’.

For DMA operation only DMA1 must be configured. Starting transfers by manually writing to the SPIx_TX_REGx shall not be done because DMA_tx_req is already ‘1’ when this mode is activated.

Reads only mode

In “reads only” mode (SPI_FIFO_MODE = “01”) only the RX-FIFO is used. Transfers will start immediately when the SPI is turned on in this mode. In transmit direction the SPI_DO pin will transmit the IO buffer contents being the actual value of the SPIx_TX_REGx (all 0’s after reset). This means that no dummy writes are needed for reads only transfers.

In **slave mode** transfers only take place if the external master initiates them, but in master mode this means that transfers will continue until the RX-FIFO is full. If this happens SPIx_CTRL_REG1[SPI_BUSY] will become ‘0’. If exactly N words need to be read from SPI device, first read (N - *fifosize*+1) words. Then wait until the SPI_BUSY becomes ‘0’, set SPI_FIFO_MODE to “00” and finally read the remaining (*fifosize* +1) words. Here *fifosize* is 4/2/1 words for 8/16/32 bits mode respectively.

If this is not done, more data will be read from the SPI device until the FIFO is completely filled, or the SPI is turned off.

For DMA operation only DMA0 must be configured. Manual transfers are not needed, as the SPI will start transferring immediately when turning on this mode.

Bidirectional transfers with FIFO

If SPI_FIFO_MODE is “00”, both registers are used as a FIFO. SPI_TXH indicates that TX-FIFO is full, SPI_INT indicates that there is data in the RX-FIFO.

DMA operation is recommended using both DMA0 and DMA1. No manual transfers are required because the requests will trigger the DMA automatically.

24.2 9 BITS MODE

The 9 bits mode can be used to support 9 bits displays and is selected with SPIx_CTRL_REG[SPI_WORD] set to ‘11’. The value of the 9th bit, set in the SPIx_CTRL_REG1[SPI_9BIT_VAL] and is used to determine if the next 8 bits form a command word or data word. Because the 9th bit is not part of the data, the FIFO’s are still used in the 8 bits mode. The 9th bit is received but not saved because it is shifted out of the 8 bits shift register upon reception.

The 9 bits command should be entered by writing to the SPIx_RX_TX_REG0, while the larger amount of data words can best be handled by the DMA controller. SPI_9BIT_VAL is set to “data mode”. To send a new command word at the end, the DMA (and SPI) must be stopped and the SPI_9BIT_VAL shall be set to “command mode” again.

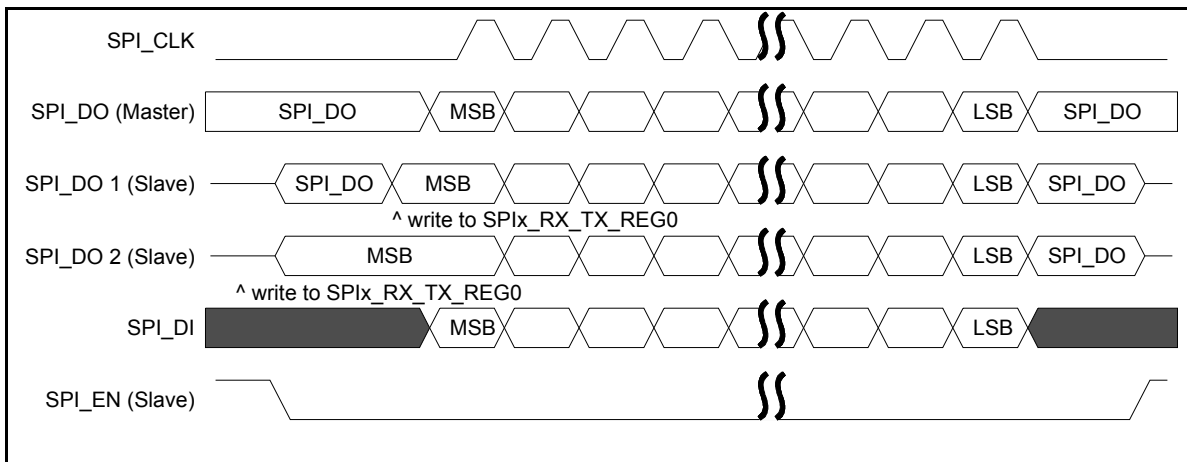

Figure 74: SPI Master/slave, mode 0: SPI_POL=0 and SPI_PHA=0

Note 5: If 9 bits SPI mode, the MSB bit in transmit direction is determined by bit SPIx_CTRL_REG[SPI_9BIT_VAL]. In receive direction, the MSB is received but not stored.

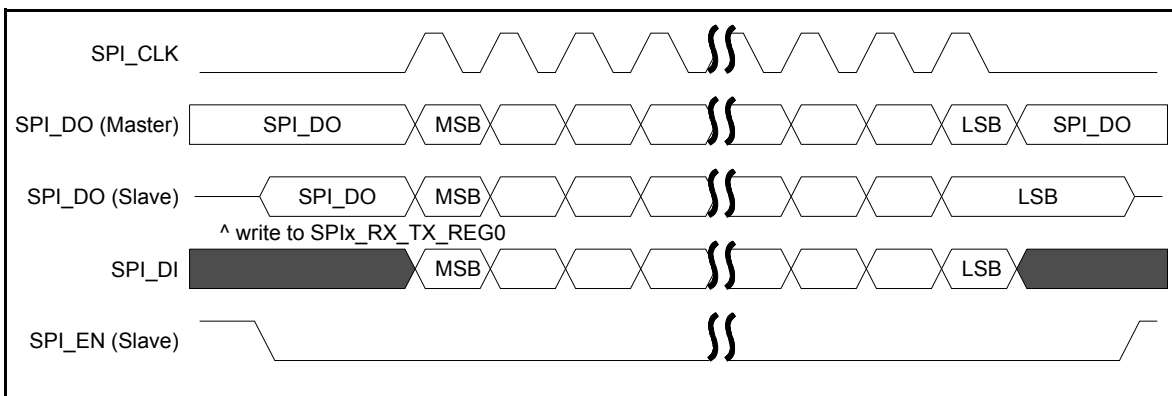

Figure 75: SPI Master/Slave, mode 1: SPI_POL=0 and SPI_PHA=1

For the MSB bit refer to Note 5.

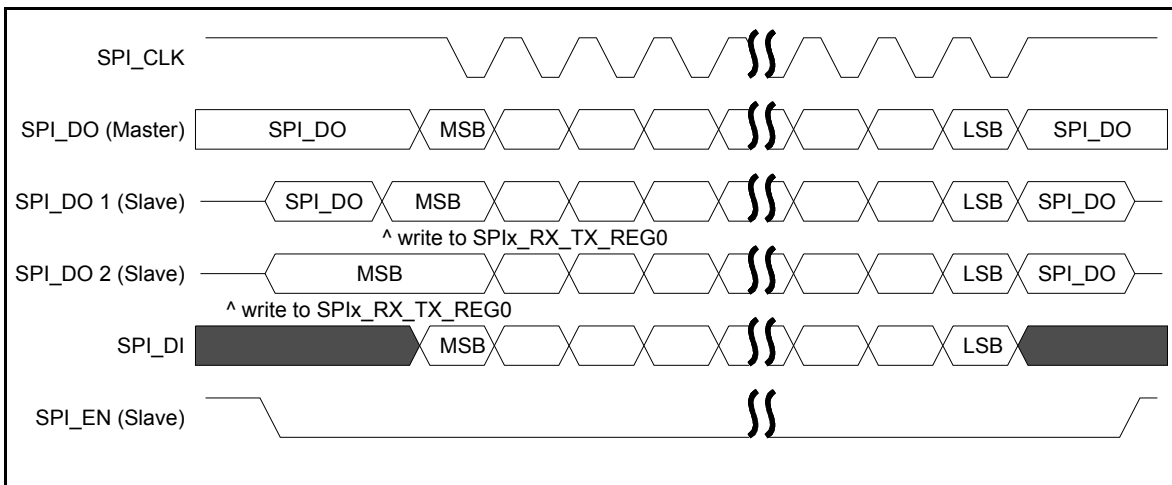

Figure 76: SPI Master/Slave, mode 2: SPI_POL=1 and SPI_PHA=0

For the MSB bit refer to Note 5.

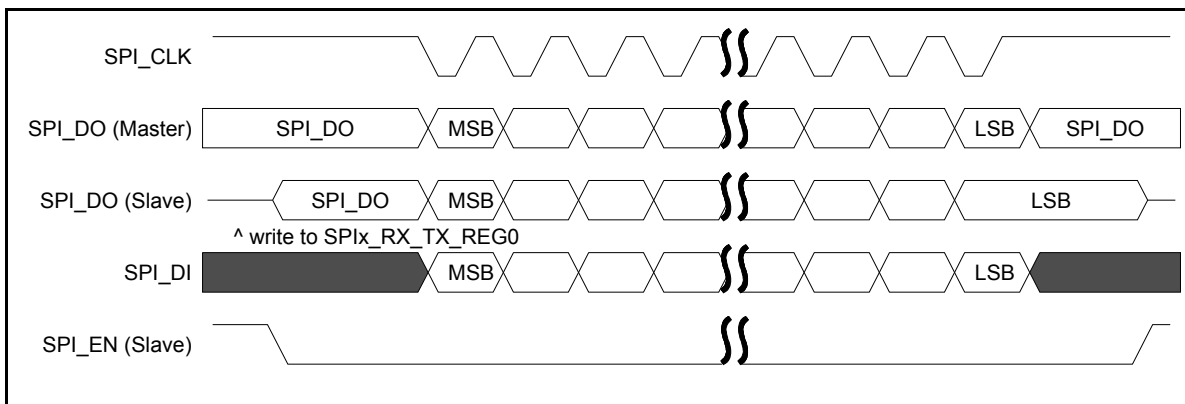

Figure 77: SPI Master/slave, mode 3: SPI_POL=1 and SPI_PHA=1

For the MSB bit refer to Note 5.

24.3 TIMING

The timing of the SPI interface when SPI controller is in slave mode is presented in the following figure:

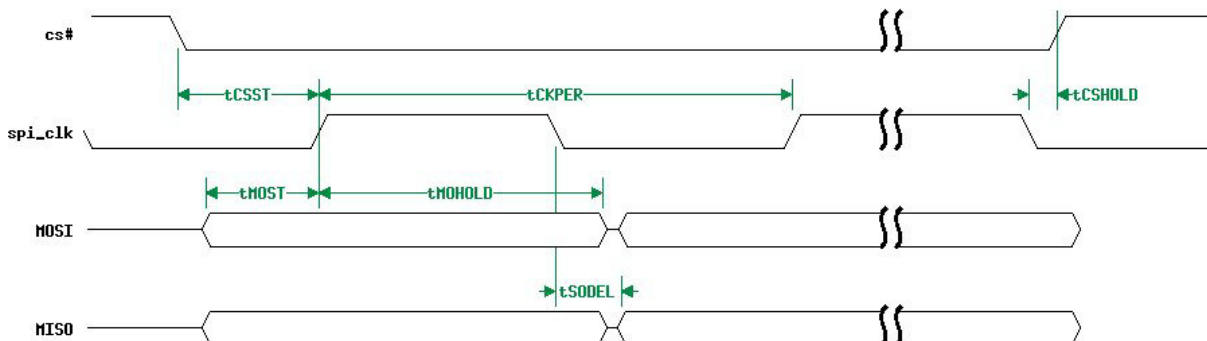

Figure 78: SPI slave mode timing (CPOL=0, CPHA=0)

Note that Tint represents the internal SPI clock period and is equal to 1.5*spi_clk period.

Table 46: SPI timing parameters

PARAMETER	DESCRIPTION	CONDITIONS	MIN	TYP	MAX	UNITS
tCLKPER	spi_clk clock period	VBAT=3V, DCDC=On	$0.25 \cdot \text{spi_clk}$	$0.25 \cdot \text{spi_clk}$	$0.25 \cdot \text{spi_clk}$	MHz
tCSST	CS active before spi_clk rising edge		$8.9 + T_{int}$	$4.5 + T_{int}$	$2.8 + T_{int}$	ns
tCSHOLD	CS stays active after falling edge of spi_clk		0	0	0	ns
tMOST	Input data latching setup time		9.3	4.6	2.8	ns
tMOHOLD	input data hold time		0	0	0	ns
tSODEL	Output data hold time		30	14.3	8.7	ns

25 I2C

The I2C is a programmable control bus that provides support for the communications link between Integrated Circuits in a system. It is a simple two-wire bus with a software-defined protocol for system control, which is used in temperature sensors and voltage level translators to EEPROMs, general-purpose I/O, A/D and D/A converters.

Two I2C controllers are instantiated in the system, namely I2C and I2C2.

Features

- Two-wire I2C serial interface consists of a serial data line (SDA) and a serial clock (SCL)
- Standard and Fast mode support (up to 400 kb/s)

- Clock synchronization
- 4 deep transmit/receive 9-bit wide FIFOs
- Master transmit, Master receive operation
- 7 or 10-bit addressing
- 7 or 10-bit combined format transfers
- Bulk transmit mode
- Default slave address of 0x055
- Interrupt or polled-mode operation
- Handles Bit and Byte waiting at both bus speeds
- Programmable SDA hold time
- DMA request signals

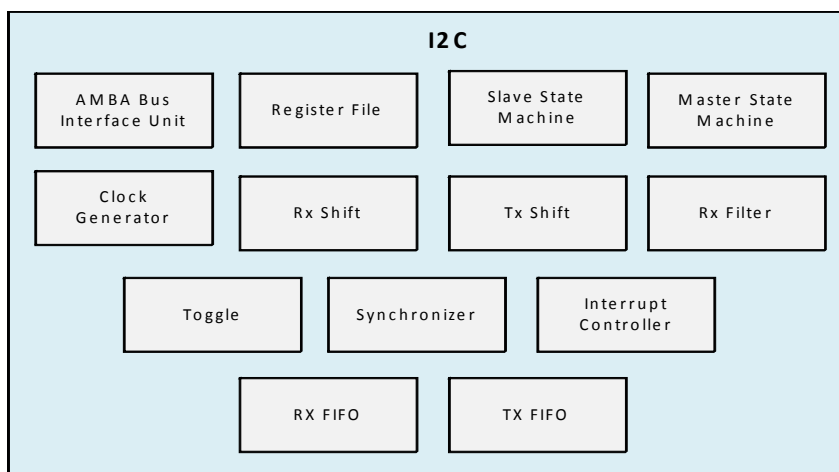

Figure 79: I2C Block diagram

The I2C controller block diagram is shown in [Figure 79](#). It contains the following sub blocks:

- **AMBA Bus Interface Unit.** Interfacing the APB interface to access the register file
- **Register File.** Contains configuration registers and is the interface with software.
- **Master State Machine.** Generates the I2C protocol for the master transfers.
- **Clock Generator.** Calculates the required timing to do the following:
 - Generate the SCL clock when configured as a master
 - Check for bus idle
 - Generate a START and a STOP
 - Setup the data and hold the data

Rx Shift. Takes data into the design and extracts it in byte format.

Tx Shift. Presents data supplied by CPU for transfer on the I2C bus.

Rx Filter. Detects the events in the bus; for example, start, stop and arbitration lost.

Toggle. Generates pulses on both sides and toggles to transfer signals across clock domains.

Synchronizer. Transfers signals from one clock domain to another.

Interrupt Controller. Generates the raw interrupt and interrupt flags, allowing them to be set and cleared.

RX FIFO/TX. Holds the RX FIFO and TX FIFO register banks and controllers, along with their status levels.

25.1 I2C BUS TERMS

The following terms relate to how the role of the I2C device and how it interacts with other I2C devices on the bus.

- **Transmitter.** the device that sends data to the bus. A transmitter can either be a device that initiates the data transmission to the bus (a master-transmitter)

or responds to a request from the master to send data to the bus (a slave-transmitter).

- Receiver. The device that receives data from the bus. A receiver can either be a device that receives data on its own request (a master-receiver) or in response to a request from the master (a slave-receiver).
- Master. The component that initializes a transfer (START command), generates the clock (SCL) signal and terminates the transfer (STOP command). A master can be either a transmitter or a receiver.
- Slave. The device addressed by the master. A slave can be either receiver or transmitter.

These concepts are illustrated in Figure 80:

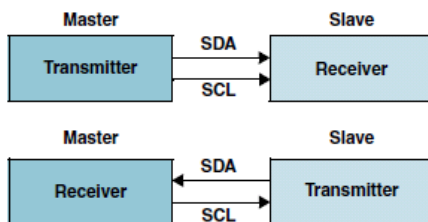

Figure 80: Master/Slave and Transmitter/Receiver Relationships

- Multi-master. The ability for more than one master to co-exist on the bus at the same time without collision or data loss.
- Arbitration. The predefined procedure that authorizes only one master at a time to take control of the bus. For more information about this behaviour, refer to Multiple Master Arbitration chapter
- Synchronization. The predefined procedure that synchronizes the clock signals provided by two or more masters. For more information about this feature, refer to Clock Synchronization chapter
- SDA. Data signal line (Serial Data)
- SCL. Clock signal line (Serial CLock)

25.1.1 Bus Transfer Terms

The following terms are specific to data transfers that occur to/from the I2C bus.

- START (RESTART). data transfer begins with a START or RESTART condition. The level of the SDA data line changes from high to low, while the SCL clock line remains high. When this occurs, the bus becomes busy.
- STOP. data transfer is terminated by a STOP condition. This occurs when the level on the SDA data line passes from the low state to the high state, while the SCL clock line remains high. When the data transfer has been terminated, the bus is free or idle once again. The bus stays busy if a RESTART is generated instead of a STOP condition.

Note 6: START and RESTART conditions are functionally identical.

25.2 I2C BEHAVIOUR

The I2C can only be controlled via software to be an I2C master only, communicating with other I2C slaves;

The master is responsible for generating the clock and controlling the transfer of data. The slave is responsible for either transmitting or receiving data to/from the master. The acknowledgement of data is sent by the device that is receiving data, which can be either a master or a slave. As mentioned previously, the I2C protocol also allows multiple masters to reside on the I2C bus and uses an arbitration procedure to determine bus ownership.

Each slave has a unique address that is determined by the system designer. When a master wants to communicate with a slave, the master transmits a START/RESTART condition that is then followed by the slave's address and a control bit (R/W) to determine if the master wants to transmit data or receive data from the slave. The slave then sends an acknowledge (ACK) pulse after the address.

If the master (master-transmitter) is writing to the slave (slave-receiver), the receiver gets one byte of data. This transaction continues until the master terminates the transmission with a STOP condition. If the master is reading from a slave (master-receiver), the slave transmits (slave-transmitter) a byte of data to the master, and the master then acknowledges the transaction with the ACK pulse. This transaction continues until the master terminates the transmission by not acknowledging (NACK) the transaction after the last byte is received, and then the master issues a STOP condition or addresses another slave after issuing a RESTART condition. This behaviour is illustrated in Figure 81:

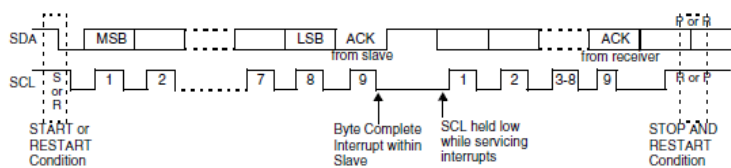

Figure 81: Data transfer on the I2C Bus

The I2C is a synchronous serial interface. The SDA line is a bidirectional signal and changes only while the SCL line is low, except for STOP, START, and RESTART conditions. The output drivers are open-drain or open-collector to perform wire-AND functions on the bus. The maximum number of devices on the bus is limited by only the maximum capacitance specification of 400 pF. Data is transmitted in byte packages.

25.2.1 START and STOP Generation

When operating as an I2C master, putting data into the transmit FIFO causes the I2C controller to generate a START condition on the I2C bus. Allowing the transmit FIFO to empty causes the I2C controller to generate a STOP condition on the I2C bus.

When operating as a slave, the I2C controller does not generate START and STOP conditions, as per the protocol. However, if a read request is made to the I2C controller, it holds the SCL line low until read data has been supplied to it. This stalls the I2C bus until read data is provided to the slave I2C controller, or the I2C controller slave is disabled by writing a 0 to I2C_ENABLE.

25.2.2 Combined Formats

The I2C controller supports mixed read and write combined format transactions in both 7-bit and 10-bit addressing modes.

The I2C controller does not support mixed address and mixed address format. That is, a 7-bit address transaction followed by a 10-bit address transaction or vice versa. Combined format transactions.

To initiate combined format transfers, I2C_CON.I2C_RESTART_EN should be set to 1. With this value set and operating as a master, when the I2C controller completes an I2C transfer, it checks the transmit FIFO and executes the next transfer. If the direction of this transfer differs from the previous transfer, the combined format is used to issue the transfer. If the transmit FIFO is empty when the current I2C transfer completes, a STOP is issued and the next transfer is issued following a START condition.

25.3 I2C PROTOCOLS

The I2C controller has the following protocols:

- START and STOP Conditions
- Addressing Slave Protocol
- Transmitting and Receiving Protocol
- START BYTE Transfer Protocol

25.3.1 START and STOP Conditions

When the bus is idle, both the SCL and SDA signals are pulled high through external pull-up resistors on the bus. When the master wants to start a transmission on the bus, the master issues a START condition. This is defined to be a high-to-low transition of the SDA signal while SCL is 1. When the master wants to terminate the transmission, the master issues a STOP condition. This is defined to be a low-to-high transition of the SDA line while SCL is 1. [Figure 82](#): shows the timing of the START and STOP conditions. When data is being transmitted on the bus, the SDA line must be stable when SCL is 1.

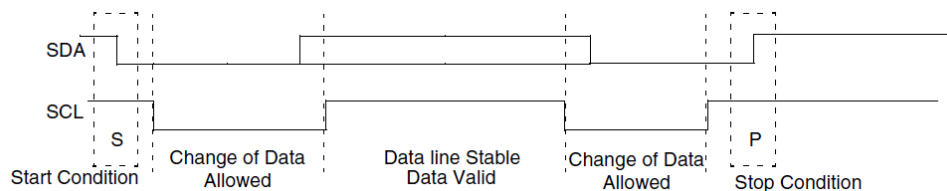

Figure 82: START and STOP Conditions

Note 7: The signal transitions for the START/STOP conditions, as depicted in [Figure 81](#), reflect those observed at the output signals of the Master driving the I2C bus. Care should be taken when observing the SDA/SCL signals at the input signals of the Slave(s), because unequal line delays may result in an incorrect SDA/SCL timing relationship.

25.3.2 Addressing Slave Protocol

There are two address formats: the 7-bit address format and the 10-bit address format.

7-bit Address Format

During the 7-bit address format, the first seven bits (bits 7:1) of the first byte set the slave address and the LSB bit (bit 0) is the R/W bit as shown in [Figure 83](#). When bit 0 (R/W) is set to 0, the master writes to the slave. When bit 0 (R/W) is set to 1, the master reads

from the slave.

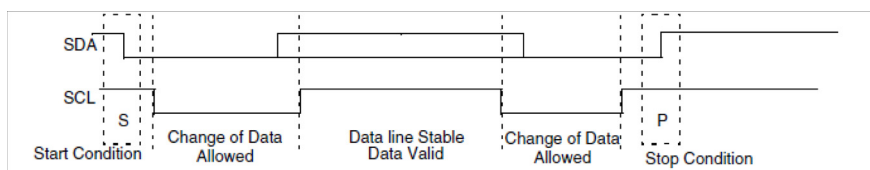

Figure 83: 7-bit Address Format

10-bit Address Format

During 10-bit addressing, two bytes are transferred to set the 10-bit address. The transfer of the first byte contains the following bit definition. The first five bits (bits 7:3) notify the slaves that this is a 10-bit transfer followed by the next two bits (bits 2:1), which set the

slaves address bits 9:8, and the LSB bit (bit 0) is the R/W bit. The second byte transferred sets bits 7:0 of the slave address. Figure 84: shows the 10-bit address format, and Table 47 defines the special purpose and reserved first byte addresses.

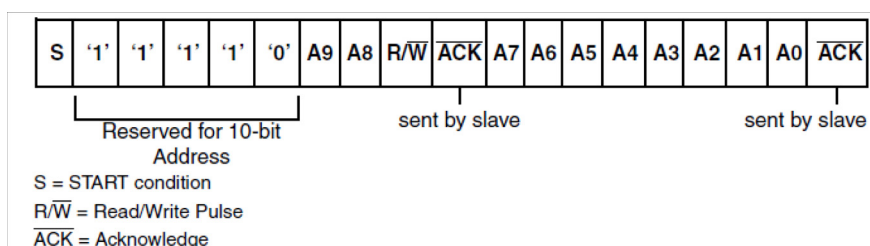

Figure 84: 10-bit Address Format

Table 47: I2C Definition of Bits in First Byte

Slave address	R/W Bits	Description
0000 000	0	General Call Address. I2C controller places the data in the receive buffer and issues a General Call interrupt.
0000 000	1	START byte. For more details, refer to “START BYTE Transfer Protocol” 0000
0000 001	X	CBUS address. I2C controller ignores these accesses
0000 010	X	Reserved
0000 011	X	Reserved
0000 1XX	X	High-speed master code (for more information, refer to “Multiple Master Arbitration”)
1111 1XX	X	Reserved
1111 0XX	X	10-bit slave addressing

I2C controller does not restrict you from using these reserved addresses. However, if you use these reserved addresses, you may run into incompatibilities with other I2C components.

25.3.3 Transmitting and Receiving Protocol

The master can initiate data transmission and reception to/from the bus, acting as either a master-transmitter or master-receiver. A slave responds to requests

from the master to either transmit data or receive data to/from the bus, acting as either a slave-transmitter or slave-receiver, respectively.

Master-Transmitter and Slave-Receiver

All data is transmitted in byte format, with no limit on the number of bytes transferred per data transfer. After the master sends the address and R/W bit or the master transmits a byte of data to the slave, the slave-receiver must respond with the acknowledge signal

(ACK). When a slave-receiver does not respond with an ACK pulse, the master aborts the transfer by issuing a STOP condition. The slave must leave the SDA line high so that the master can abort the transfer.

If the master-transmitter is transmitting data as shown in Figure 85, then the slave-receiver responds to the master-transmitter with an acknowledge pulse after every byte of data is received.

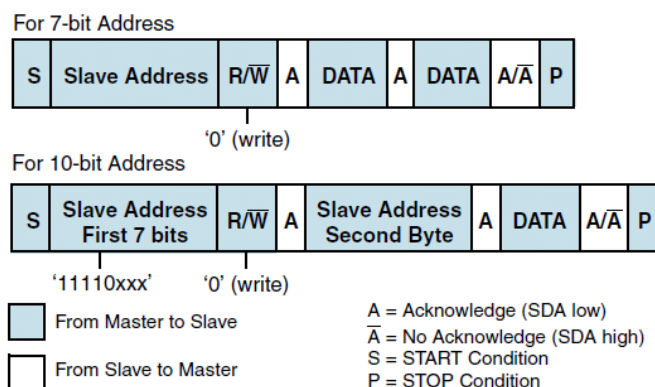

Figure 85: Master-Transmitter Protocol

Master-Receiver and Slave-Transmitter

If the master is receiving data as shown in Figure 86: then the master responds to the slave-transmitter with an acknowledge pulse after a byte of data has been received, except for the last byte. This is the way the master-receiver notifies the slave-transmitter that this is the last byte. The slave-transmitter relinquishes the SDA line after detecting the No Acknowledge (NACK) so that the master can issue a STOP condition.

When a master does not want to relinquish the bus with a STOP condition, the master can issue a RESTART condition. This is identical to a START condition except it occurs after the ACK pulse. The master can then communicate with the same slave or a different slave.

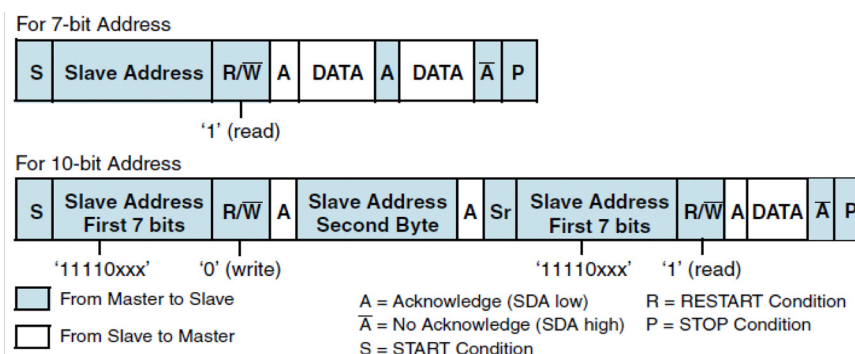

Figure 86: Master-Receiver Protocol

START BYTE Transfer Protocol

The START BYTE transfer protocol is set up for systems that do not have an on-board dedicated I2C hardware module. When the I2C controller is addressed as a slave, it always samples the I2C bus at the highest speed supported so that it never requires a START BYTE transfer. However, when I2C controller is a master, it supports the generation of START BYTE transfers at the beginning of every transfer in case a slave

device requires it. This protocol consists of seven zeros being transmitted followed by a 1, as illustrated in Figure 87. This allows the processor that is polling the bus to under-sample the address phase until 0 is detected. Once the microcontroller detects a 0, it switches from the under sampling rate to the correct rate of the master.

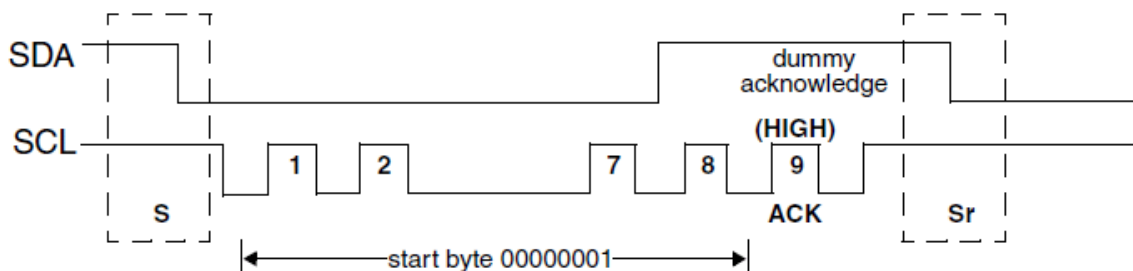

Figure 87: START BYTE Transfer

The START BYTE procedure is as follows:

1. Master generates a START condition.
2. Master transmits the START byte (0000 0001).
3. Master transmits the ACK clock pulse. (Present only to conform with the byte handling format used on the bus)
4. No slave sets the ACK signal to 0.
5. Master generates a RESTART (R) condition.

A hardware receiver does not respond to the START BYTE because it is a reserved address and resets after the RESTART condition is generated.

25.4 MULTIPLE MASTER ARBITRATION

The I2C controller bus protocol allows multiple masters to reside on the same bus. If there are two masters on the same I2C-bus, there is an arbitration procedure if both try to take control of the bus at the same time by generating a START condition at the same time. Once a master (for example, a microcontroller) has control of the bus, no other master can take control until the first master sends a STOP condition and places the bus in an idle state.

Arbitration takes place on the SDA line, while the SCL line is 1. The master, which transmits a 1 while the other master transmits 0, loses arbitration and turns off its data output stage. The master that lost arbitration can continue to generate clocks until the end of the byte transfer. If both masters are addressing the same slave device, the arbitration could go into the data phase. Figure 88: illustrates the timing of when two masters are arbitrating on the bus.

For high-speed mode, the arbitration cannot go into the data phase because each master is programmed with a unique high-speed master code. This 8-bitcode is

defined by the system designer and is set by writing to the High Speed Master Mode Code Address Register, I2C_HS_MADDR. Because the codes are unique, only one master can win arbitration, which occurs by the end of the transmission of the high-speed master code.

Control of the bus is determined by address or master code and data sent by competing masters, so there is no central master nor any order of priority on the bus.

Arbitration is not allowed between the following conditions:

- A RESTART condition and a data bit
- A STOP condition and a data bit
- A RESTART condition and a STOP condition

Slaves are not involved in the arbitration process.

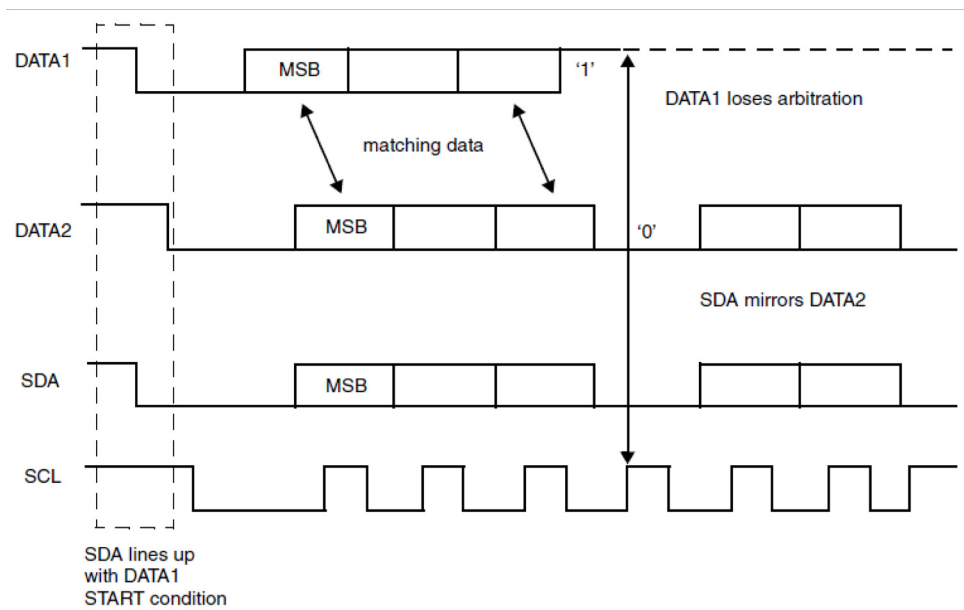

Figure 88: Multiple Master Arbitration

25.5 CLOCK SYNCHRONIZATION

When two or more masters try to transfer information on the bus at the same time, they must arbitrate and synchronize the SCL clock. All masters generate their own clock to transfer messages. Data is valid only during the high period of SCL clock. Clock synchronization is performed using the wired-AND connection to the SCL signal. When the master transitions the SCL clock to 0, the master starts counting the low time of the SCL clock and transitions the SCL clock signal to 1 at the beginning of the next clock period. However, if another master is holding the SCL line to 0, then the master

goes into a HIGH wait state until the SCL clock line transitions to 1.

All masters then count off their high time, and the master with the shortest high time transitions the SCL line to 0. The masters then counts out their low time and the one with the longest low time forces the other master into a HIGH wait state. Therefore, a synchronized SCL clock is generated, which is illustrated in Figure 89. Optionally, slaves may hold the SCL line low to slow down the timing on the I2C bus.

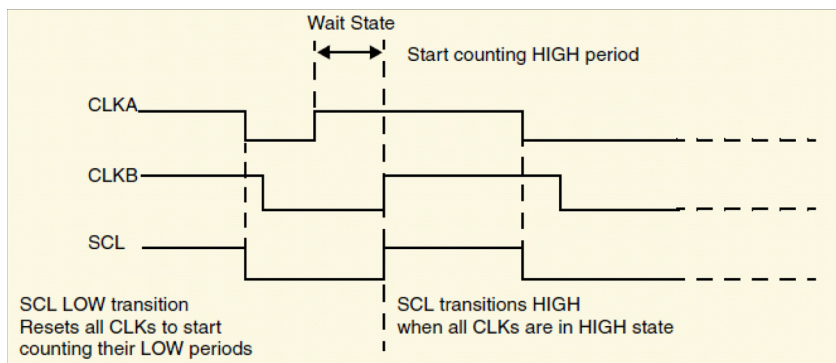

Figure 89: Multiple Master Clock synchronization.

25.6 OPERATION MODES

This section provides information on the following topics:

- Slave Mode Operation
- Master Mode Operation
- Disabling I2C controller

Note 8: It is important to note that the I2C controller should only be set to operate as an I2C Master, or I2C Slave, but not both simultaneously. This is achieved by ensuring that bit 6 (I2C_SLAVE_DISABLE) and 0 (I2C_MASTER_MODE) of the I2C_CON register are never set to 0 and 1, respectively.

25.6.1 Slave Mode Operation

This section includes the following procedures:

- Initial Configuration
- Slave-Transmitter Operation for a Single Byte
- Slave-Receiver Operation for a Single Byte
- Slave-Transfer Operation For Bulk Transfers

Initial Configuration

To use the I2C controller as a slave, perform the following steps:

1. Disable the I2C controller by writing a '0' to bit 0 of the I2C_ENABLE register.
2. Write to the I2C_SAR register (bits 9:0) to set the slave address. This is the address to which the I2C controller responds.
3. Write to the I2C_CON register to specify which type of addressing is supported (7- or 10-bit by setting bit 3). Enable the I2C controller in slave-only mode by writing a '0' into bit 6 (I2C_SLAVE_DISABLE) and a '0' to bit 0 (MASTER_MODE).

Note 9: Slaves and masters do not have to be programmed with the same type of addressing 7- or 10-bit address. For instance, a slave can be programmed with 7-bit addressing and a master with 10-bit addressing, and vice versa.

4. Enable the I2C controller by writing a '1' in bit 0 of the I2C_ENABLE register.

Note 10: Depending on the reset values chosen, steps 2 and 3 may not be necessary because the reset values can be configured. For instance, if the device is only going to be a master, there would be no need to set the slave address because you can configure I2C controller to have the slave disabled after reset and to enable the master after reset. The values stored are static and do not need to be reprogrammed if the I2C controller is disabled.

Slave-Transmitter Operation for a Single Byte

When another I2C master device on the bus addresses the I2C controller and requests data, the I2C controller acts as a slave-transmitter and the following steps occur:

1. The other I2C master device initiates an I2C transfer with an address that matches the slave address in the I2C_SAR register of the I2C controller.

2. The I2C controller acknowledges the sent address and recognizes the direction of the transfer to indicate that it is acting as a slave-transmitter.

3. The I2C controller asserts the RD_REQ interrupt (bit 5 of the I2C_RAW_INTR_STAT register) and holds the SCL line low. It is in a wait state until software responds. If the RD_REQ interrupt has been masked, due to I2C_INTR_MASK[5] register (M_RD_REQ bit field) being set to 0, then it is recommended that a hardware and/or software timing routine be used to instruct the CPU to perform periodic reads of the I2C_RAW_INTR_STAT register.

- a. Reads that indicate I2C_RAW_INTR_STAT[5] (R_RD_REQ bit field) being set to 1 must be treated as the equivalent of the RD_REQ interrupt being asserted.

- b. Software must then act to satisfy the I2C transfer.

- c. The timing interval used should be in the order of 10 times the fastest SCL clock period the I2C controller can handle. For example, for 400 kb/s, the timing interval is 25us.

Note 11: The value of 10 is recommended here because this is approximately the amount of time required for a single byte of data transferred on the I2C bus.

4. If there is any data remaining in the TX FIFO before receiving the read request, then the I2C controller asserts a TX_ABRT interrupt (bit 6 of the I2C_RAW_INTR_STAT register) to flush the old data from the TX FIFO.

Note 12: Because the I2C controller's TX FIFO is forced into a flushed/reset state whenever a TX_ABRT event occurs, it is necessary for software to release the I2C controller from this state by reading the I2C_CLR_TX_ABRT register before attempting to write into the TX FIFO. See register I2C_RAW_INTR_STAT for more details.

If the TX_ABRT interrupt has been masked, due to of I2C_INTR_MASK[6] register (M_TX_ABRT bit field) being set to 0, then it is recommended that re-using the timing routine (described in the previous step), or a similar one, be used to read the I2C_RAW_INTR_STAT register.

- a. Reads that indicate bit 6 (R_TX_ABRT) being set to 1 must be treated as the equivalent of the TX_ABRT interrupt being asserted.

- b. There is no further action required from software.

- c. The timing interval used should be similar to that described in the previous step for the I2C_RAW_INTR_STAT[5] register.

5. Software writes to the I2C_DATA_CMD register with the data to be written (by writing a '0' in bit 8).

6. Software must clear the RD_REQ and TX_ABRT interrupts (bits 5 and 6, respectively) of the I2C_RAW_INTR_STAT register before proceeding.

If the RD_REQ and/or TX_ABRT interrupts have been masked, then clearing of the I2C_RAW_INTR_STAT register will have already been performed when either the R_RD_REQ or R_TX_ABRT bit has been read as 1.

7. The I2C controller releases the SCL and transmits the byte.

8. The master may hold the I2C bus by issuing a RESTART condition or release the bus by issuing a STOP condition.

Slave-Receiver Operation for a Single Byte

When another I2C master device on the bus addresses the I2C controller and is sending data, the I2C controller acts as a slave-receiver and the following steps occur:

1. The other I2C master device initiates an I2C transfer with an address that matches the I2C controller's slave address in the I2C_SAR register.

2. The I2C controller acknowledges the sent address and recognizes the direction of the transfer to indicate that the I2C controller is acting as a slave-receiver.

3. I2C controller receives the transmitted byte and places it in the receive buffer.

Note 13: If the RX FIFO is completely filled with data when a byte is pushed, then an overflow occurs and the I2C controller continues with subsequent I2C transfers. Because a NACK is not generated, software must recognize the overflow when indicated by the I2C controller (by the R_RX_OVER bit in the I2C_INTR_STAT register) and take appropriate actions to recover from lost data. Hence, there is a real time constraint on software to service the RX FIFO before the latter overflow as there is no way to re-apply pressure to the remote transmitting master. You must select a deep enough RX FIFO depth to satisfy the interrupt service interval of their system.

4. I2C controller asserts the RX_FULL interrupt (I2C_RAW_INTR_STAT[2] register).

If the RX_FULL interrupt has been masked, due to setting I2C_INTR_MASK[2] register to 0 or setting I2C_TX_TL to a value larger than 0, then it is recommended that a timing routine (described in "Slave-Transmitter Operation for a Single Byte") be implemented for periodic reads of the "I2C_STATUS" on page 138 register. Reads of the I2C_STATUS register, with bit 3 (RFNE) set at 1, must then be treated by software as the equivalent of the RX_FULL interrupt being asserted.

5. Software may read the byte from the I2C_DATA_CMD register (bits 7:0).

6. The other master device may hold the I2C bus by issuing a RESTART condition or release the bus by issuing a STOP condition.

Slave-Transfer Operation For Bulk Transfers

In the standard I2C protocol, all transactions are single byte transactions and the programmer responds to a remote master read request by writing one byte into the slave's TX FIFO. When a slave (slave-transmitter) is issued with a read request (RD_REQ) from the remote master (master-receiver), at a minimum there should be at least one entry placed into the slave-transmitter's TX FIFO.

I2C controller is designed to handle more data in the TX FIFO so that subsequent read requests can take that data without raising an interrupt to get more data. Ultimately, this eliminates the possibility of significant latencies being incurred between raising the interrupt for data each time had there been a restriction of having only one entry placed in the TX FIFO.

This mode only occurs when I2C controller is acting as a slave-transmitter. If the remote master acknowledges the data sent by the slave-transmitter and there is no data in the slave's TX FIFO, the I2C controller holds the I2C SCL line low while it raises the read request interrupt (RD_REQ) and waits for data to be written into the TX FIFO before it can be sent to the remote master.

If the RD_REQ interrupt is masked, due to bit 5 (M_RD_REQ) of the I2C_INTR_STAT register being set to 0, then it is recommended that a timing routine be used to activate periodic reads of the I2C_RAW_INTR_STAT register. Reads of I2C_RAW_INTR_STAT that return bit 5 (R_RD_REQ) set to 1 must be treated as the equivalent of the RD_REQ interrupt referred to in this section. This timing routine is similar to that described in "Slave-Transmitter Operation for a Single Byte"

The RD_REQ interrupt is raised upon a read request, and like interrupts, must be cleared when exiting the interrupt service handling routine (ISR). The ISR allows you to either write 1 byte or more than 1 byte into the TX FIFO. During the transmission of these bytes to the master, if the master acknowledges the last byte, then the slave must raise the RD_REQ again because the master is requesting for more data.

If the programmer knows in advance that the remote master is requesting a packet of n bytes, then when another master addresses I2C controller and requests data, the TX FIFO could be written with n number bytes and the remote master receives it as a continuous stream of data. For example, the I2C controller slave continues to send data to the remote master as long as the remote master is acknowledging the data sent and there is data available in the TX FIFO. There is no need to hold the SCL line low or to issue RD_REQ again.

If the remote master is to receive n bytes from the I2C controller but the programmer wrote a number of bytes larger than n to the TX FIFO, then when the slave finishes sending the requested n bytes, it clears the TX FIFO and ignores any excess bytes.

The the I2C controller generates a transmit abort (TX_ABRT) event to indicate the clearing of the TX FIFO in this example. At the time an ACK/NACK is expected, if a NACK is received, then the remote master has all the data it wants. At this time, a flag is raised within the slave's state machine to clear the leftover data in the TX FIFO. This flag is transferred to the processor bus clock domain where the FIFO exists and the contents of the TX FIFO is cleared at that time.

25.6.2 Master Mode Operation

This section includes the following topics:

- Initial Configuration
- Dynamic I2C_TAR or I2C_10BITADDR_MASTER Update
- Master Transmit and Master Receive

Initial Configuration

The procedures are very similar and are only different with regard to where the I2C_10BITADDR_MASTER bit is set (either bit 4 of I2C_CON register or bit 12 of I2C_TAR register).

To use the I2C controller as a master perform the following steps:

1. Disable the I2C controller by writing 0 to the I2C_ENABLE register.
2. Write to the I2C_CON register to set the maximum speed mode supported (bits 2:1) and the desired speed of the I2C controller master-initiated transfers, either 7-bit or 10-bit addressing (bit 4).

Ensure that bit 6 I2C_SLAVE_DISABLE = 1 and bit 0 MASTER_MODE = 1

Note 14: Slaves and masters do not have to be programmed with the same type of addressing 7- or 10-bit address. For instance, a slave can be programmed with 7-bit addressing and a master with 10-bit addressing, and vice versa.

3. Write to the I2C_TAR register the address of the I2C device to be addressed (bits 9:0). This register also indicates whether a General Call or a START BYTE command is going to be performed by I2C.
4. Only applicable for high-speed mode transfers. Write to the I2C_HS_MADDR register the desired master code for the I2C controller. The master code is programmer-defined.
5. Enable the I2C controller by writing a 1 in bit 0 of the I2C_ENABLE register.
6. Now write transfer direction and data to be sent to the I2C_DATA_CMD register. If the I2C_DATA_CMD register is written before the I2C controller is enabled, the data and commands are lost as the buffers are kept cleared when I2C controller is disabled.

This step generates the START condition and the address byte on the I2C controller. Once I2C controller is enabled and there is data in the TX FIFO, I2C controller starts reading the data.

Note 15: Depending on the reset values chosen, steps 2, 3, 4, and 5 may not be necessary because the reset values can be configured. The values stored are static and do not need to be reprogrammed if the I2C controller is disabled, with the exception of the transfer direction and data.

Master Transmit and Master Receive

The I2C Controller supports switching back and forth between reading and writing dynamically. To transmit data, write the data to be written to the lower byte of the I2C_DATA_CMD_REG register. The CMD bit [8] should be written to 0 for I2C write operations.

Subsequently, a read command may be issued by writing "don't cares" to the lower byte of the I2C_DATA_CMD_REG register, and a 1 should be written to the CMD bit.

The I2C Controller master continues to initiate transfers as long as there are commands present in the transmit FIFO. If the transmit FIFO becomes empty, the master inserts a STOP condition after completing the current transfer.

Disabling I2C controller

The register I2C_ENABLE_STATUS is added to allow software to unambiguously determine when the hardware has completely shutdown in response to the I2C_ENABLE register being set from 1 to 0. Only one register is required to be monitored.

Procedure:

1. Define a timer interval (ti2c_poll) equal to the 10 times the signalling period for the highest I2C transfer speed used in the system and supported by I2C controller. For example, if the highest I2C transfer mode is 400 kb/s, then this ti2c_poll is 25us.
2. Define a maximum time-out parameter, MAX_T_POLL_COUNT, such that if any repeated polling operation exceeds this maximum value, an error is reported.
3. Execute a blocking thread/process/function that prevents any further I2C master transactions to be started by software, but allows any pending transfers to be completed.

Note 16: This step can be ignored if I2C controller is programmed to operate as an I2C slave only.

4. The variable POLL_COUNT is initialized to zero.
 5. Set I2C_ENABLE to 0.
 6. Read the I2C_ENABLE_STATUS register and test the I2C_EN bit (bit 0). Increment POLL_COUNT by one. If POLL_COUNT >= MAX_T_POLL_COUNT, exit with the relevant error code.
 7. If I2C_ENABLE_STATUS[0] is 1, then sleep for ti2c_poll and proceed to the previous step.
- Otherwise, exit with a relevant success code.

26 InfraRed Generator

The InfraRed generator provides a flexible way of transmitting any IR code used in remote controls. It has an efficient message queue where users can describe the waveform of a specific IR command in just a few bytes independently from the protocol. It sits on the 16-bit APB bus and receives a separate, up to 16MHz clock used for the carrier generation.

Features

- Carrier frequencies from 30 to 60 KHz
- Supports Pulse width and Pulse Distance encoding
- Supports Manchester encoding
- Supports Time mode (no carrier)
- Any combination of Mark and Space symbols
- Code FIFO of 32 16-bit words for encoding commands
- Automatic Repeat function, transparent to SW
- Interrupt generation upon transmit completion

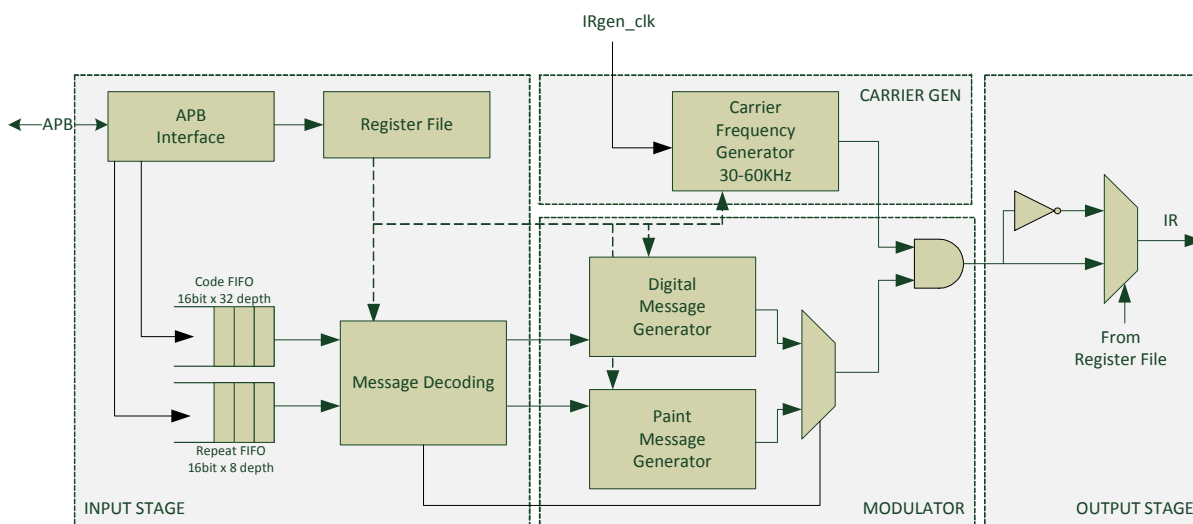

Figure 90: InfraRed Generator Block Diagram

26.1 ARCHITECTURE

The IR generator, is based upon the concept of using two different ways of describing data, being able to support any IR protocol:

- **Digital Message:** This message represents a logic 1 or a logic 0 and is clearly described in form of Mark and Space duration as well as sequence.
- **Paint Message:** This message represents a totally custom "painted" waveform. The way of efficiently describing this, is to encode the symbol type (Mark/

Space) and the symbol duration within a code word for HW to be able to understand and proceed accordingly to the correct modulation.

The composition of a command consists of a number of control words which contain information about digital or paint messages in an efficient way. A breakdown of the well-known IR code NEC command is presented in the following figure as an example:

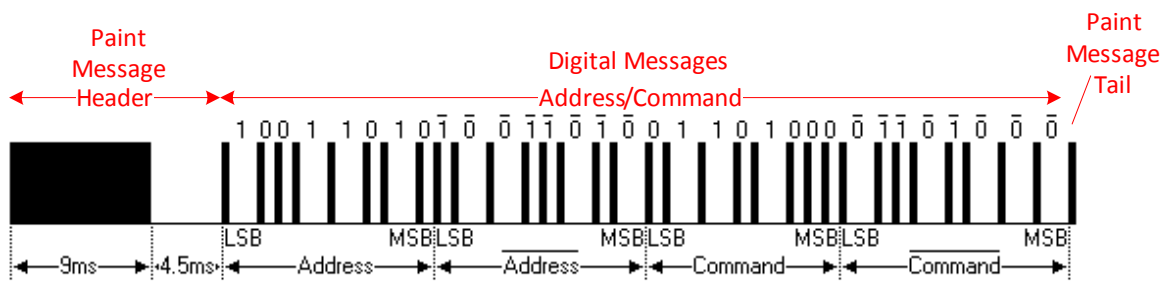

Figure 91: Paint/Digital messages on a NEC based example

The encoding of the Paint/Digital messages can be implemented according to the following tables:

Table 48: IR Digital Message Encoding

Bit	Name	Description
15	Message Type	1 = Digital message. That means that the message information itself defines logic 1 or logic 0
14:11	Message Length	Number of valid bits minus 1. Range 0 to 10
10:0	Message Payload	Digital Message consisting of logic 1s and logic 0s

Table 49: IR Paint Message Encoding

Bit	Name	Description
15	Message Type	0 = Paint message
14	Symbol Type	1 = Mark 0 = Space
13:0	Duration	Mark/Space duration in carrier clock cycles

So, basically, the MSbit of the word defines if the message is a digital or a paint one.

The block consists of four sub-blocks:

Input Stage

it consists of the APB interface the Register File, 2 FIFOs and the Message Decoding engine. This sub-block is responsible for the configuration of the system and the storage and decoding of the encoded words. These words will reside in the Code FIFO. The Repeat FIFO can be used to load special commands for repeating a key press i.e. this is only protocol dependent. The output of the Code FIFO is decoded by the Message Decoding engine and pushed in forms of commands into the next sub-block, the modulator. This sub-block is also responsible for firing up the repeat timer in case that a key is constantly pressed. The repetition time as well the message to be sent varies according to the protocol.

Carrier Generator

This sub-block is responsible for the carrier frequency generation. It has its own gated clock which can be up to 16MHz and can generate frequencies in the range of 30 - 60 KHz.

Modulator

This sub-block is responsible for the generation of the modulation signal which gates the carrier clock pulse train. The Modulator state machine select between digital or pain message and controls the gate accordingly.

Output Stage

This sub-block can be programmed to invert the output optionally

26.2 PROGRAMMING

Initially the clock of the block has to be enabled by asserting the CLK_PER_REG[IR_CLK_ENABLE] bit. The carrier ON and OFF time in clock cycles have to be programmed at IR_FREQ_CARRIER_Oxx_REGS. Following that, the logic one and zero are defined in terms of clock cycles high (mark) and clock cycles low (zero) with help of the IR_LOGIC_ONE/ZERO_TIME_REGS

Another important feature that needs to be initialized is whether the logic one/zero start with a mark and is followed by a zero, or the other way around. This is defined in IR_CTRL_REG[IR_LOGIC_ONE_FORMAT] and IR_CTRL_REG[IR_LOGIC_ZERO_FORMAT] respectively. Finally, the time required for an automated retransmit is defined at IR_REPEAT_TIME_REG.

Sending commands using a specific protocol is simply writing the correct words into the Code FIFO and then set IR_CTRL_REG[IR_TX_START] to trigger the transmission. The actual word values have to comply to the encoding schemes as presented in [Table 48](#) and [Table 49](#).

27 Quadrature Decoder

The DA14681 has an integrated quadrature decoder that can automatically decode the signals for the X, Y and Z axes of a HID input device, reporting step count and direction. This block can be used for waking up the chip as soon as there is any kind of movement from the external device connected to it. The block diagram of the quadrature decoder is presented in Figure 92.

Features

- Three 16-bit signed counters that provide the step count and direction on each of the axes (X, Y and Z)
- Programmable system clock sampling at maximum 16 MHz.
- APB interface for control and programming
- Programmable source from P0, P1 and P2 ports
- Digital filter on the channel inputs to avoid spikes

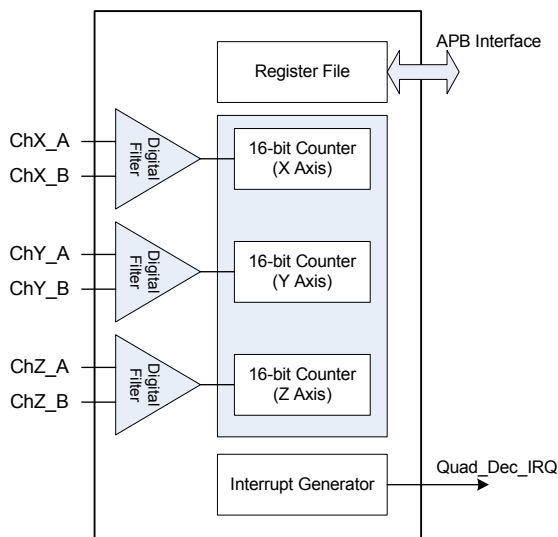

Figure 92: Block diagram of the Quadrature Decoder

27.1 ARCHITECTURE

Channels are expected to provide a pulse train with 90 degrees rotation as displayed in Figure 93 and Figure 94.

Depending on whether channel A or channel B is leading in phase, the quadrature decoding block calculates the direction on the related axis. Furthermore, the signed counter value represents the number of steps moved.

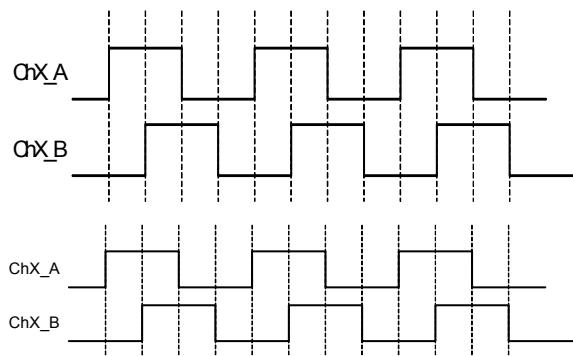

Figure 93: Moving forward on axis X

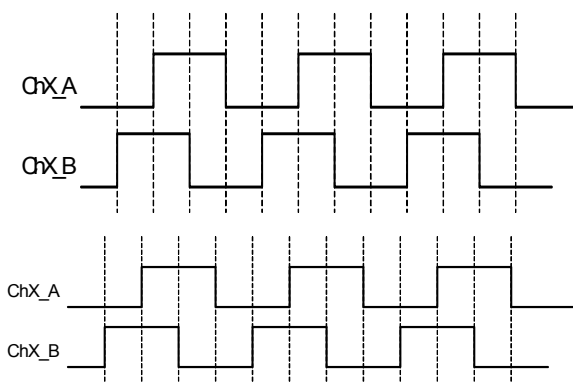

Figure 94: Moving backwards on axis X

27.2 PROGRAMMING

Since six channels are required (two for each axis), any GPIO can be mapped onto this block. The user can choose which GPIOs to use for the channels by programming the Pxy_MODE_REG[PID] with values from 30 up to 44.

The digital filter eliminates any spike shorter than two clock periods. The counter holds the movement events of the channel. When a channel is disabled the counter is reset. The counters are accessible via the APB bus.

The quadrature decoder operates on the system clock. The QDEC_CLOCKDIV register defines the number of clock cycles of the period at which the decoding logic samples the data on the channel inputs.

The interrupt block monitors the movement events and generates an interrupt every N events. The value for N is defined in the QDEC_CTRL register.

Note: if there are events from multiple channels in the same cycle, the interrupt event counter is only increased by one.

28 Keyboard Scanner

The Keyboard Scanner is a programmable hardware state machine which takes care of scanning the keyboard matrix and providing a clear view of key presses/releases to SW. Once enabled, it takes care of any key press or release without interfering with the CPU up to the point that a de-bounced key press is identified. It operates at a programmable frequency clock, allowing for a very short scan cycle time. Debouncing of up to 12 simultaneous keys is allowed with dedicated counters. The resulting events are reported in a FIFO which triggers an interrupt to the CPU at the end of the scan cycle.

The block diagram of the Keyboard Controller is presented in [Figure 95](#).

Features

- Autonomous keyboard matrix scan without CPU interference
- 250 kHz clock for low power
- Maximum 16 Rows / 32 Columns support for any GPIO
- Up to 12, 7-bit de-bounce counters, counting matrix scan cycles
- Different press and release debounce times support
- Configurable row activation time
- Short scan cycle (1.3 us for a 10x10 matrix using 16 MHz clock)
- Row/Column report for a key press/release

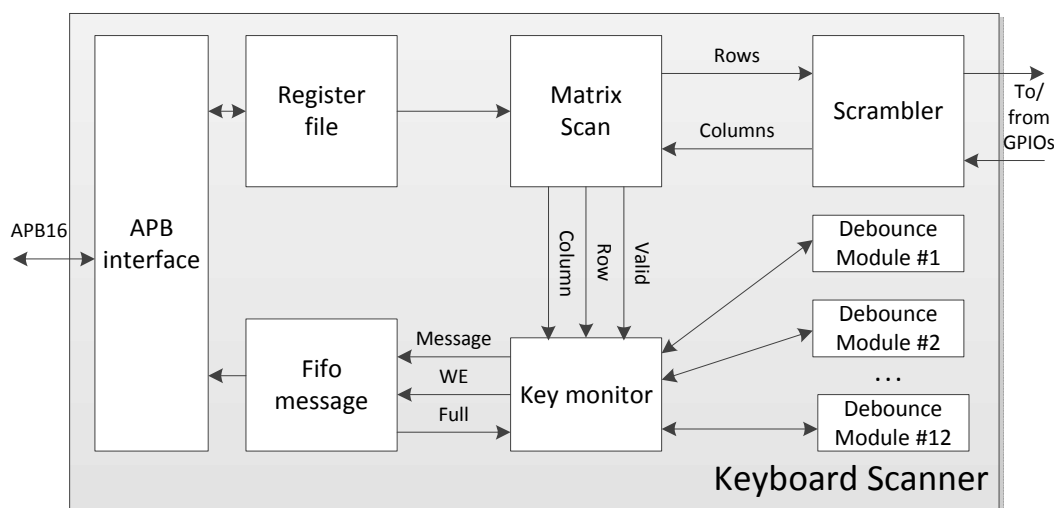

Figure 95: Keyboard Scanner block diagram

28.1 ARCHITECTURE

The Keyboard Scanner comprises a Key Monitoring state machine which controls the 12 Debouncing Modules, a Matrix Scan state machine which is responsible for a totally automated scan of the preferred key matrix, a FIFO which reports to the CPU what has been pressed/released and an APB based register file which is used to configure the block. A Scrambler is also utilized to allow for flexibility in selecting GPIOs used as rows or columns in the key matrix. Finally, the Key Monitor gathers the column/row identities for an event (key press or release), controls the 12 debouncing modules and writes the message into the FIFO triggering an interrupt to the CPU.

The Scrambler is implementing the assignment of specific GPIOs as rows (outputs) or columns (inputs) to form a matrix as shown in the example of [Figure 96](#).

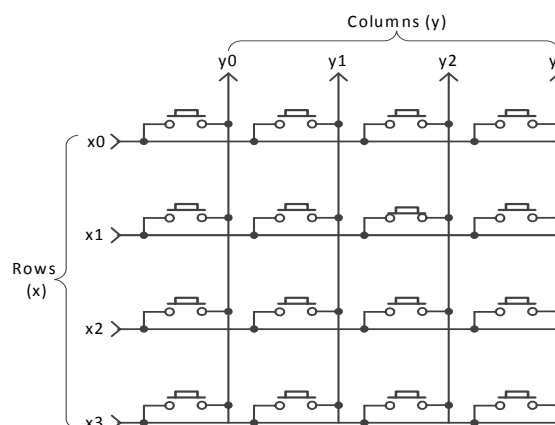

Figure 96: 4x4 Keyboard Matrix example

The configuration of the GPIOs can be realized with use of the KBSCN_GPIOx_MODE_REG. The actual size of the matrix should be programmed in KBSCN_MATRIX_SIZE_REG.

The Matrix Scan block implements a finite state

machine which takes care of the full scanning of the key matrix without the CPU intervention. The scan cycle is presented in the following figure:

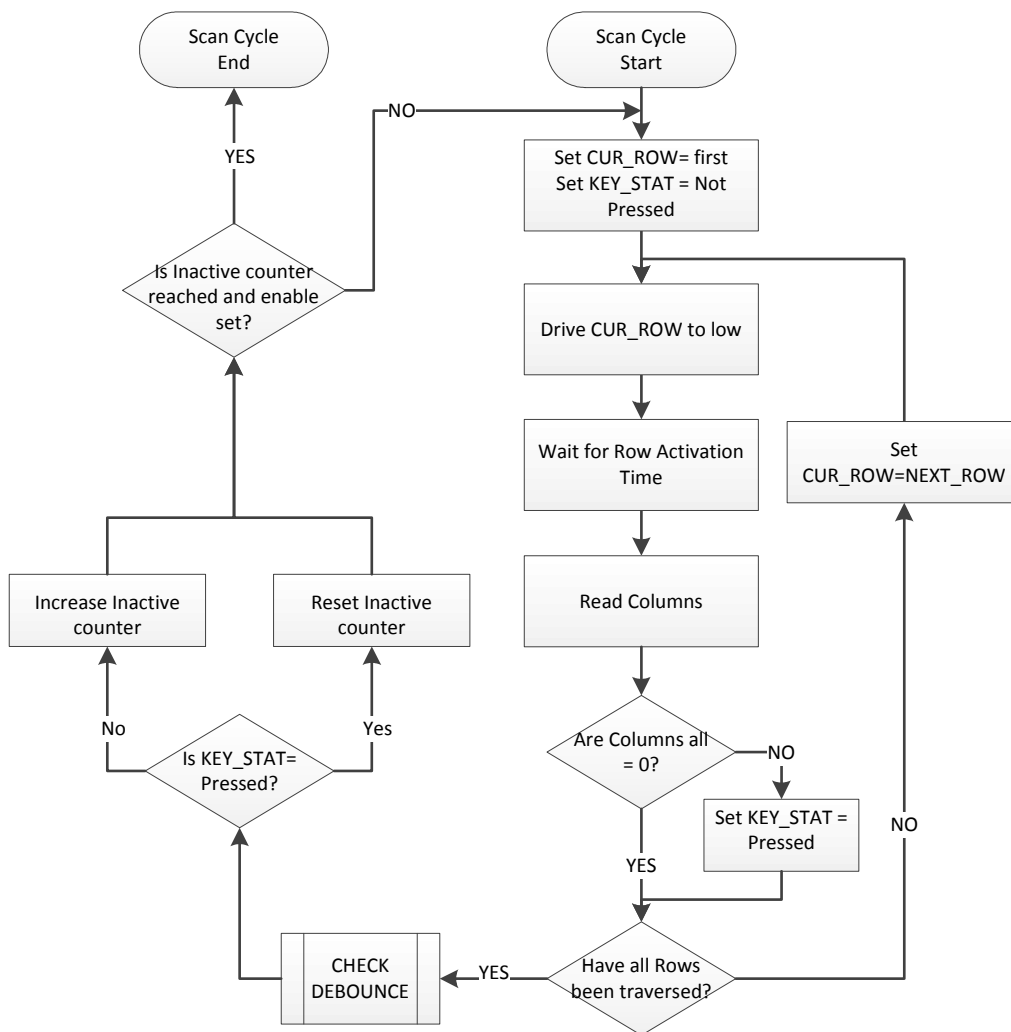

Figure 97: Scan cycle state machine

The FSM is setting each row to '0', waits for a pre-configured amount of time (activation time, programmed in KBSCN_CTRL2_REG) and then it reads the columns vector. If no zeros are sensed in the columns word, it continues scanning until all rows have been exercised.

If there is a key press while scanning, a flag (KEY_STAT) changes value. Flag KEY_STAT is also set when debouncing (for a key press or release) is in progress. As soon as the whole matrix has been scanned, the debouncer modules are started. These are incremented per scan cycle until a programmed value is reached (KBSCN_DEBOUNCE_REG). Up to 12 concurrent debouncing operations are supported.

Next, the FSM checks on the inactivity of the key

matrix. Setting bit KBSCN_CTRL_REG[KBSCN_INACTIVE_EN]=1 will automatically stop the scanning activity if KBSCN_CTRL_REG[KBSCN_INACTIVE_TIME] scan cycles have elapsed without any key press or debounce activity. If bit KBSCN_CTRL_REG[KBSCN_INACTIVE_EN]=0, the scanning activity will continue.

A key press/release message is prepared and stored in the FIFO for the CPU after every scan cycle provided that an event has been sensed. Each message is 11 bit wide and can be read at KBSCN_MESSAGE_KEY_REG. Multiple messages are possible in the case of multiple events (presses or

releases). Its structure is presented in the table below:

Table 50: Keyboard Scanner Message Structure

Bit	Description
10	Designates if this is the last message of this scan cycle. If it is high, then the value if the register is 0xFF (the rest of the bits are all high as well)
9	Key state. 0: key is pressed, 1: key is released
8:4	Defines the number of the column of the key event
3:0	Defines the number of the row of the key event

An interrupt is triggered towards the CPU in three cases:

1. A message has been placed in the message FIFO
2. There is an underflow/overflow of the message FIFO
3. The inactive time (in scan cycles) has elapsed

This information as well as the actual amount of messages residing in the FIFO can be accessed at KBSCN_STATUS_REG. Note that, the FIFO can be erased by SW using KBSCN_CTRL_REG[KBSCN_RESET_FIFO].

The number of KEYB_CLK cycles required for a full scan cycle is given by the formula below:

$C_{scan} = N_{ROWS} * (C_{ACT} + 2)$, where C_{ACT} is the amount of clocks for the activation time as programmed in KBSCN_CTRL2_REG[KBSCN_ROW_ACTIVE_TIME] and N_{ROWS} the number of rows.

The clock can be 250 kHz up to 96 MHz if the PLL is enabled.

28.2 PROGRAMMING

To initialize the Keyboard Scanner, the clock has to be first enabled by setting CLK_PER_REG[KBSCAN_ENABLE]=1 and KBSCN_CTRL_REG[KBSCN_CLKDIV] to the preferred value. The latter defines the clock frequency of the block, when the clock divider is enabled by setting CLK_PER_REG[KBSCAN_CLK_SEL]=0.

Following that, the rows have to be programmed in output mode via the Pxy_MODE_REG registers. There is a dedicated PID for this namely number 47 (KB_ROW). The rows have to be explicitly defined as pulled-up inputs with use of the respective Pxy_MODE_REG registers.

Both rows and columns need to be defined in the KBSCN_GPIOz_MODE_REG so that the Keyboard Scanner understands which I/O is what.

The row active time, i.e. the time needed for the key matrix to settle after applying a high or low level, has to be programmed in the register field KBSCN_CTRL2_REG[KBSCN_ROW_ACTIVE_TIME]. This value represents keyboard scanner clock cycles.

The Matrix size has to be configured in KBSCN_MATRIX_SIZE_REG and the debounce times for press and release (can be different) should be programmed at KBSCN_DEBOUNCE_REG. Reset value is 0x1 which means no debounce at all.

A special feature enables the scanning to automatically stop after KBSCN_CTRL_REG[KBSCN_INACTIVE_TIME] clock cycles have elapsed without activity. Last thing to do for the initialization is enable the interrupt of the Keyboard Scanner by KBSCN_CTRL_REG[KBSCN_IRQ_FIFO_MASK] = 1 and KBSCN_CTRL_REG[KBSCN_IRQ_MESSAGE_MASK] = 1 and enable the block by setting KBSCN_CTRL_REG[KBSCN_EN]=1.

The interrupt triggers the CPU to read a message residing in the 12-words FIFO by reading the KBSCN_MESSAGE_KEY_REG. This message contains the key id that was recently pressed or released as well as the indication of being or not, the only message in the FIFO (KBSCN_LAST_ENTRY).

29 Software Timers

The Software Timer block contains 3 timer modules that are software controlled, programmable and can be used for various tasks. Timer0 is a 16-bit general purpose timer with a PWM output capability. Timer2 is a 14-bit counter that generates three identical PWM signals in a quite flexible manner.

29.1 TIMER0

Timer0 is a 16-bit general purpose software programmable timer, which has the ability of generating Pulse Width Modulated signals, namely PWM0 and PWM1. It also generates the SWTIM_IRQ interrupt to the ARM Cortex M0. It can be configured in various modes regarding output frequency, duty cycle and the modulation of the PWM signals.

Features

- 16-bit general purpose timer
- Ability to generate 2 Pulse Width Modulated signals (i.e. PWM0 and PWM1)
- Programmable output frequency:
 $f = (16, 8, 4, 2 \text{ MHz or } 32 \text{ kHz}) / (M+1) + (N+1)$
 with $N = 0$ to $(2^{**}16)-1$, $M = 0$ to $(2^{**}16)-1$
- Programmable duty cycle:
 $\delta = (M+1) / ((M+1) + (N+1)) * 100\%$
- Separately programmable interrupt timer:
 $T = (16, 8, 4, 2 \text{ MHz or } 32 \text{ kHz}) / (ON+1)$

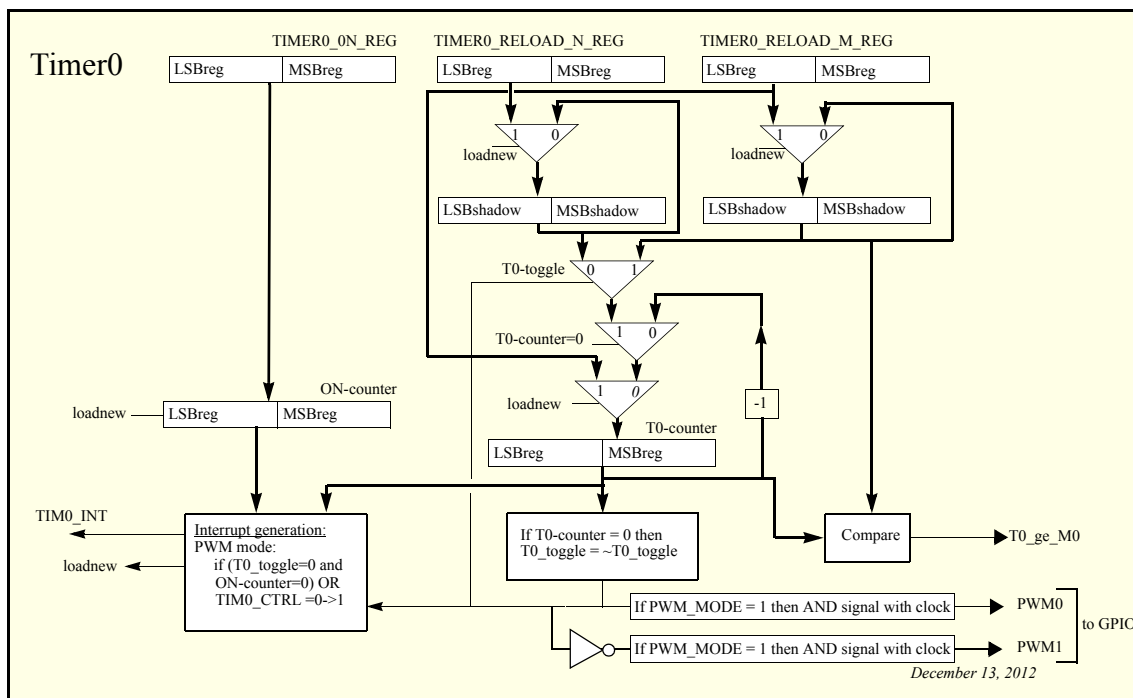

Figure 98: Timer0 block diagram

Figure 98 shows the block diagram of Timer0. The 16 bits timer consists of two counters: T0-counter and ON-counter, and three registers: TIMER0_RELOAD_M_REG, TIMER0_RELOAD_N_REG and TIMER0_ON_REG. Upon reset, the counter and register values are 0x0000. Timer0 will generate a Pulse Width Modulated signal PWM0. The frequency and duty cycle of PWM0 are determined by the contents of the TIMER0_RELOAD_N_REG and the TIMER0_RELOAD_M_REG registers.

The timer can run at five different clocks: 16 MHz, 8 MHz, 4 MHz, 2 MHz or 32 kHz. The 32 kHz clock is selected by default with bit TIM0_CLK_SEL in the TIMER0_CTRL_REG register. This 'slow' clock has no

enabling bit. The other four options can be selected by setting the TIM0_CLK_SEL bit and the TMR_ENABLE bit in the CLK_PER_REG (default disabled). This register also controls the frequency via the TMR_DIV bits. An extra clock divider is available that can be activated via bit TIM0_CLK_DIV of the timer control register TIMER0_CTRL_REG. This clock divider is only used for the ON-counter and always divides by 10.

Timer0 operates in PWM mode. The signals PWM0 and PWM1 can be mapped to any GPIOs.

Timer0 PWM mode

If bit TIM0_CTRL in the TIMER0_CTRL_REG is set, Timer0 will start running. SWTIM_IRQ will be generated and the T0-counter will load its start value from

the `TIMER0_RELOAD_M_REG` register, and will decrement on each clock. The ON-counter also loads its start value from the `TIMER0_ON_REG` register and decrements with the selected clock.

When the T0-counter reaches zero, the internal signal T0-toggle will be toggled to select the `TIMER0_RELOAD_N_REG` whose value will be loaded in the T0-counter. Each time the T0-counter reaches zero it will alternately be reloaded with the values of the M0- and N0-shadow registers respectively. PWM0 will be high when the M0-value decrements and low when the N0-value decrements. For PWM1 the opposite is applicable since it is inverted. If bit `PWM_MODE` in the `TIMER0_CTRL_REG` register is set, the PWM signals are not HIGH during the 'high time' but output a clock in that stage. The frequency is based on the clock settings defined in the `CLK_PER_REG` register (also in 32 kHz mode), but the selected clock frequency is divided by two to get a 50 % duty cycle.

If the ON-counter reaches zero it will remain zero until the T0-counter also reaches zero, while decrementing the value loaded from the `TIMER0_RELOAD_N_REG` register (PWM0 is low). The counter will then generate an interrupt

(`SWTIM_IRQ`). The ON-counter will be reloaded with the value of the `TIMER0_ON_REG` register. The T0-counter as well as the M0-shadow register will be loaded with the value of the `TIMER0_RELOAD_M_REG` register. At the same time, the N0-shadow register will be loaded by the `TIMER0_RELOAD_N_REG` register. Both counters will be decremented on the next clock again and the sequence will be repeated.

Note that it is possible to generate interrupts at a high rate, when selecting a high clock frequency in combination with low counter values. This could result in missed interrupt events.

During the time that the ON-counter is non-zero, new values for the ON-register, M0-register and N0-register can be written, but they are not used by the T0-counter until a full cycle is finished. More specifically, the newly written values in the `TIMER0_RELOAD_M_REG` and `TIMER0_RELOAD_N_REG` registers are only stored into the shadow registers when the ON-counter and the T0-counter have both reached zero and the T0-counter was decrementing the value loaded from the `TIMER0_RELOAD_N_REG` register (see [Figure 99](#)).

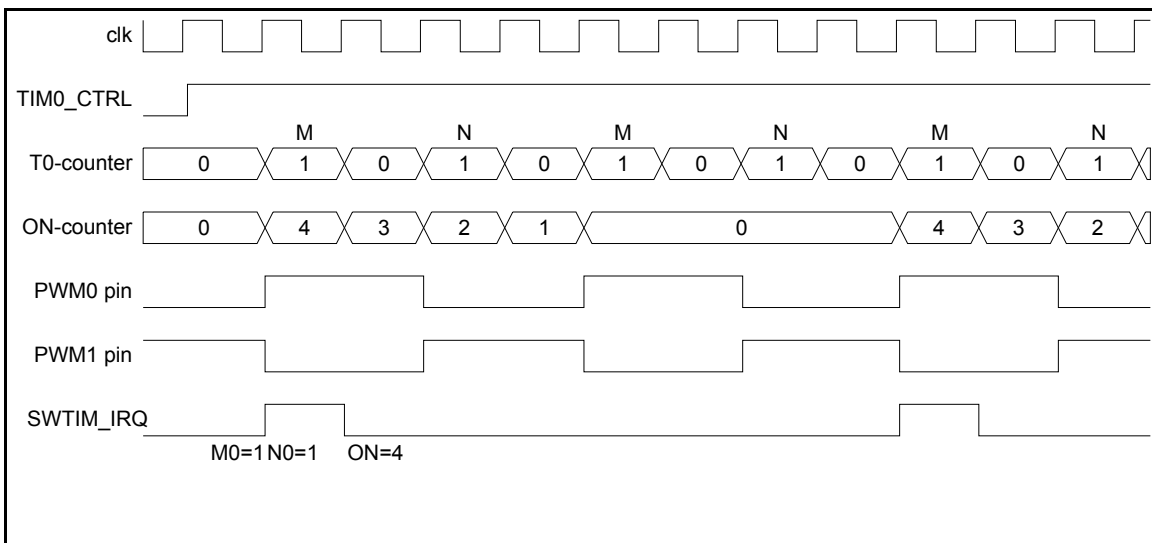

Figure 99: Timer 0 Pulse PWM mode

At start-up both counters and the PWM0 signal are LOW so also at start-up an interrupt is generated. If Timer0 is disabled all flip-flops, counters and outputs are in reset state except for the ON-register, the `TIMER0_RELOAD_N_REG` register and the `TIMER0_RELOAD_M_REG` register.

The timer input registers ON-register, `TIMER0_RELOAD_N_REG` and `TIMER0_RELOAD_M_REG` can be written and the counter registers ON-counter and T0-counter can be read. When reading from the address of the ON-register, the value of the ON-counter is returned. Reading

from the address of either the `TIMER0_RELOAD_N_REG` or the `TIMER0_RELOAD_M_REG` register, returns the value of the T0-counter.

It is possible to freeze Timer0 with bit `FRZ_SWTIM` of the register `SET_FREEZE_REG`. When the timer is frozen the timer counters are not decremented. This will freeze all the timer registers at their last value. The timer will continue its operation again when bit `FRZ_SWTIM` is cleared via register `RESET_FREEZE_REG`.

29.2 TIMER1

Timer1 is a 16-bit up/down timer with capture input (2 channels) and one shot pulse capability. This timer is also able of generating a PWM signal with programmable output frequency. Timer1 is the only timer that stays alive when the DA14681 is in sleep mode. It counts using the sleep clock and can still control one output, namely the P0_6 while the rest of the IOs are frozen to reduce power dissipation.

Features

- 16-bit general purpose timer
- Generates a Pulse Width Modulated signal (PWM5)
- 2 channels for capture input triggering
- One shot pulse with programmable pulse width
- 16-bit clock pre-scaler
- Up/down counting capability with free running mode
- Operating at sleep clock when system is in sleep mode
- Counts while in Extended Sleep mode.
- PW5 controls the P0_6 output while in Extended Sleep mode
- Programmable output frequency
 $F = 16 \text{ MHz}/2 \text{ to } 16 \text{ MHz}/((2^{**14})-1)$
- Dedicated interrupt line

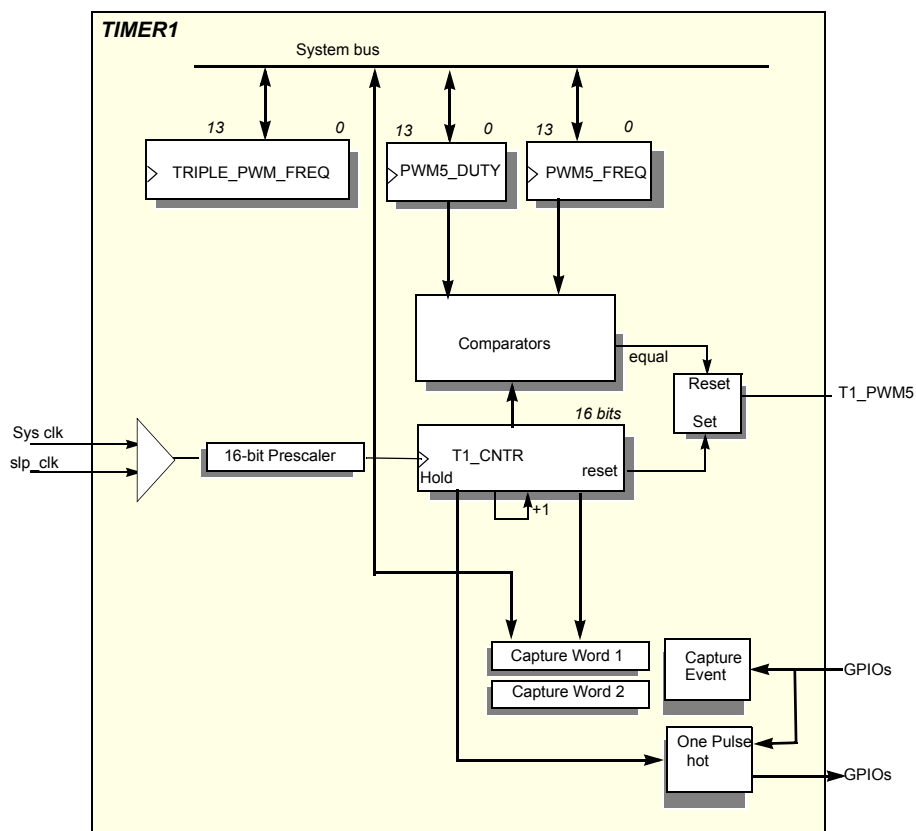

Figure 100: PWM Timer 1 block diagram

Timer1 is enabled by `CAPTIM_CTRL_REG[CAPTIM_EN]` bit. This is the only timer that supports up/down counting with means of programming the `CAPTIM_CTRL_REG[CAPTIM_COUNT_DOWN_EN]` bit.

Timer1 supports capturing 2 externally triggered events (positive or negative edges) on GPIOs that can be selected. When the first event is captured, the current value of the 16-bit free-running timer is stored into

`CAPTIM_CAPTURE_GPIO1_REG` while upon triggering of the second event, the current timer value is stored into `CAPTIM_CAPTURE_GPIO2_REG`. In this way, the timing interval between 2 successive events can be measured with precision.

The Timer1 support one shot pulse (`CAPTIM_CTRL_REG[CAPTIM_ONESHOT_MODE_EN]`). Whenever either of the two externally selected GPIOs triggers an event, a programmable width pulse

(CAPTIM_SHOTWIDTH_REG) will be output on another GPIO programmed by Pxx_MODE_REG[PID]=53. Furthermore, the time up to the start of the pulse is again configurable by CAPTIM_RELOAD_REG.

Timer1 is kept alive while the system is in Extended Sleep mode. The PWM5 signal which can be configured by CAPTIM_PWM_FREQ_REG and CAPTIM_PWM_DC_REG with respect to the frequency and duty cycle is automatically connected to the P0_6 pin output buffer. Hence, if enabled (CLK_TMR_REG[P06_TMR1_PWM_MODE]=1), P0_6

can be driving external devices even during extended sleep. However, Timer1 will not work in sleep mode if CLK_TMR_REG[TMR1_DIV] has a value different than 0.

Note that, the PWM functionality is decoupled from the timer1 counting which can be read at CAPTIM_TIMER_VAL_REG at any given time while the chip is in active mode.

An overview of the timer modes, reset values and interrupt generation is presented in the following table:

Table 51: Timer1 interrupt generation

Mode	Reset Value	Interrupt Generated
Count up with Reload	0	When reload value reached
Count down with Reload	CAPTIM_RELOAD_REG	When 0 reached
Count up free running	0	When reload value reached

29.3 TIMER2

Timer2 has three Pulse Width Modulated (PWM) outputs. The block diagram is shown in [Figure 101](#).

Features

- 14-bit general purpose timer
- Generates 3 Pulse Width Modulated signals (i.e. PWM2, PWM3 and PWM4)
- Input Clock frequency 16 MHz
- Programmable output frequency
 $F = 16 \text{ MHz} / 2 \text{ to } 16 \text{ MHz} / ((2^{**14}) - 1)$
- Three outputs with Programmable duty cycle from 0% to 100%
- Used for white LED intensity (on/off) control

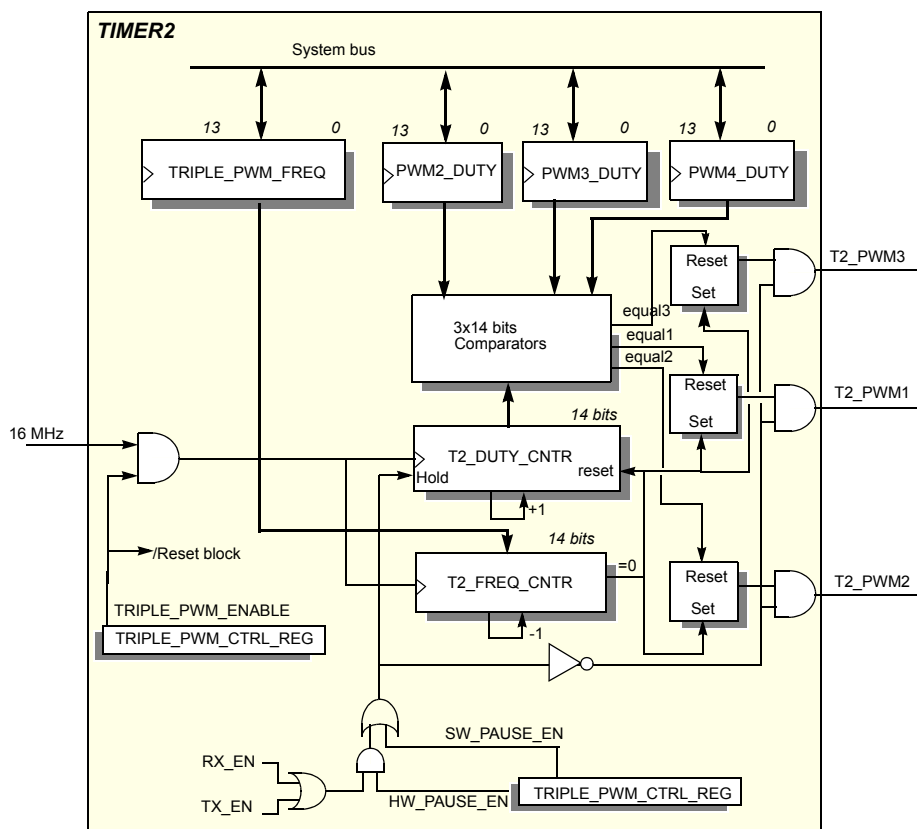

Figure 101: PWM Timer 2 block diagram

The Timer2 is clocked with the system clock (16 MHz) and can be enabled with `TRIPLE_PWM_CTRL_REG[TRIPLE_PWM_ENABLE]`.

`T2_FREQ_CNTR` determines the output frequency of the `T2_PWMn` output. This counter counts down from the value stored in register `TRIPLE_PWM_FREQUENCY`. At counter value 0, `T2_FREQ_CNTR` sets the `T2_PWMn` output to '1' and the counter is reloaded again.

`T2_DUTY_CNTR` is an up-counter that determines the duty cycle of the `T2_PWMn` output signal. After the block is enabled, the counter starts from 0. If `T2_DUTY_CNTR` is equal to the value stored in the respective `PWMn_DUTY_CYCLE` register, this resets the `T2_PWMn` output to 0. `T2_DUTY_CNTR` is reset when `TRIPLE_PWM_FREQUENCY` is 0.

Note that the value of `PWMn_DUTY_CYCLE` must be less or equal than `TRIPLE_PWM_FREQUENCY`.

Another feature of Timer2 PWM signals is the fact that the start and end cycle of the PWM wave can be programmed separately for the three signals using the `PWMx_START_CYCLE` and `PWMx_END_CYCLE`. In this way, the PWM signals can be configured to imple-

ment a certain phase shift. These signals also control the LED pins with means of `LED_CONTROL_REG[LEDx_SRC_SEL]`.

The Timer2 is enabled/disabled by programming the `TRIPLE_PWM_CTRL_REG[TRIPLE_PWM_EN]` bit.

The timing diagram of Timer2 is shown in [Figure 102](#).

Freeze function

During RF activity it may be desirable to temporarily suppress the PWM switching noise. This can be done by setting `TRIPLE_PWM_CTRL_REG[HW_PAUSE_EN] = 1`. The effect is that whenever there is a transmission or a reception process from the Radio, `T2_DUTY_CNTR` is frozen and `T2_PWMx` output is switched to '0' to disable the selected `T2_PWM1`, `T2_PWM2`, `T2_PWM3`. As soon as the Radio is idle (i.e. `RX_EN` or `TX_EN` signals are zero), `T2_DUTY_CNTR` resumes counting and finalizes the remaining part of the PWM duty cycle.

`TRIPLE_PWM_CTRL_REG[SW_PAUSE_EN]` can be set to '0' to disable the automatic, hardware driven freeze function of the duty counter and keep the duty cycle constant.

Note that the RX_EN and TX_EN signals are not software driven but controlled by the BLE core hardware.

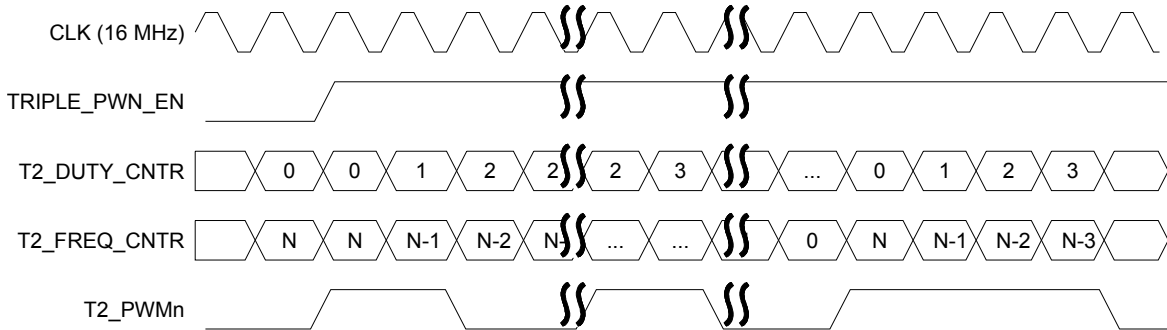

Figure 102: Timer 2 PWM timing diagram

29.4 BRTH_TIMER

This timer implements an automated breathing function for external LEDs without software interference. The resulting PWM signal can be mapped on any of the GPIOs of the system. It uses the system clock as input.

Features

- Maximum and minimum duty cycle configuration
- PWM duty cycle step granularity up to 256
- Input clock frequency 16 MHz
- Programmable output frequency
 $f = f_{\text{system}} / (1 \text{ to } 256) \text{ MHz}$

30 Watchdog Timer

The watchdog timer is an 8-bit timer with sign bit that can be used to detect an unexpected execution sequence caused by a software run-away and can generate a full system reset or a Non-Maskable Interrupt (NMI). Upon expiration, a HW reset is triggered.

Features

- 8 bits down counter with sign bit, clocked with a 10.24 ms clock for a maximum 2.6 s time-out.

- Non-Maskable Interrupt (NMI) or WDOG reset.
- Optional automatic WDOG reset if NMI handler fails to update the Watchdog register.
- Non maskable Watchdog freeze of the Cortex-M0 Debug module when the Cortex-M0 is halted in Debug state.
- Maskable Watchdog freeze by user program.

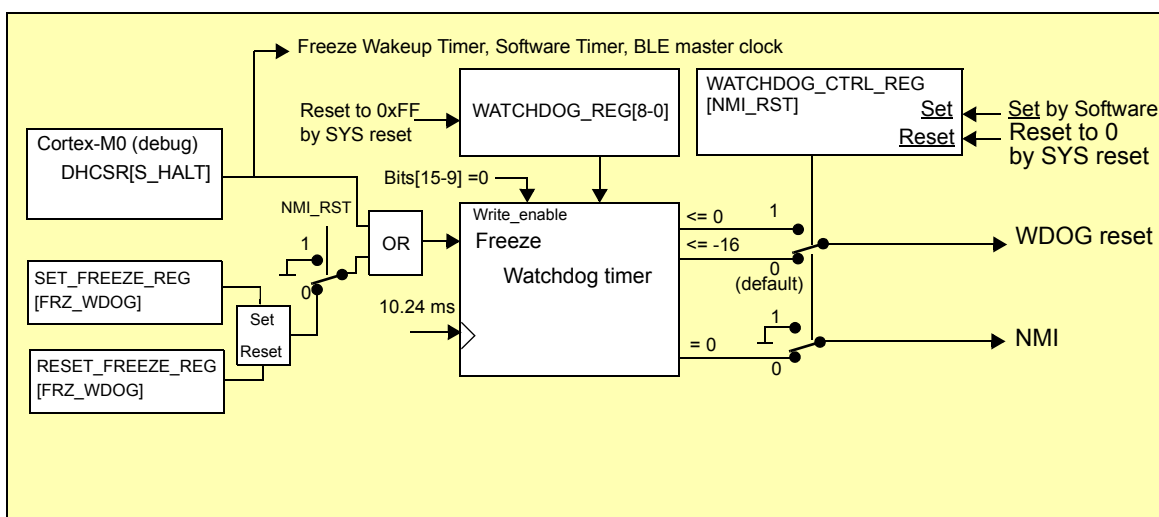

Figure 103: Watchdog Timer block diagram

The 8 bits watchdog timer is decremented by 1 every 10.24 ms. The timer value can be accessed through the WATCHDOG_REG register which is set to 255 (FF_{16}) at reset. This results in a maximum watchdog time-out of ~ 2.6 s. During write access the WATCHDOG_REG[WDOG_WEN] bits must be 0. This provides extra filtering for a software run-away writing all ones to the WATCHDOG_REG. If the watchdog counter reaches 0, the counter value will get a negative value by setting bit 8. The counter sequence becomes 1, 0, $1FF_{16}$ (-1), $1FE_{16}$ (-2), ... $1F0_{16}$ (-16).

If WATCHDOG_CTRL_REG[NMI_RST] = 0, the watchdog timer will generate an NMI if the watchdog timer reaches 0 and a WDOG reset if the counter becomes less or equal to -16 ($1F0_{16}$). The NMI handler must write any value > -16 to the WATCHDOG_REG to prevent the generation of a WDOG reset at counter value -16 after $16 \times 10.24 = 163.8$ ms.

If WATCHDOG_CTRL_REG[NMI_RST] = 1, the watchdog timer generates a WDOG reset if the timer becomes less or equal than 0.

The WDOG reset is one of the SYS (system) reset sources and resets the whole device, including setting the WATCHDOG_REG register to 255, except for the RST pin, the Power On reset, the HW reset and the DBG (debug module) reset. Since the HW reset is not

triggered, the SYS_CTRL_REG[REMAP_ADR0] bits will retain their value and the Cortex-M0 will start executing again from the current selected memory at address zero. Refer to the "Reset" chapter for an overview of the complete reset circuit and conditions.

For debugging purposes, the Cortex-M0 Debug module can always freeze the watchdog by setting the DHCSR[DBGKEY | C_HALT | C_DEBUGEN] control bits (reflected by the status bit S_HALT). This is automatically done by the debug tool, e.g. during step-by-step debugging. Note that this bit also freezes the Wakeup Timer, the Software Timer and the BLE master clock. For additional information also see the DEBUG_REG[DEBUGS_FREEZE_EN] mask register. The C_DEBUGEN bit is not accessible by the user software to prevent freezing the watchdog.

In addition to the S_HALT bit, the watchdog timer can also be frozen if NMI_RST=0 and SET_FREEZE_REG [FRZ_WDOG] is set to '1'. The watchdog timer resumes counting when RESET_FREEZE_REG[FRZ_WDOG] is set to '1'. The WATCHDOG_CTRL_REG[NMI_RST] bit can only be set by software and will only be reset on a SYS reset.

31 USB Interface

The USB interface is an integrated USB Node controller compatible with the full and low speed USB specification version 1.1.

It integrates a Serial Interface Engine (SIE) and USB endpoint (EP) FIFOs. Seven endpoint pipes are supported: one for the mandatory control endpoint and six to support interrupt endpoints. Each endpoint pipe has a dedicated FIFO, 8 bytes for the control endpoint and 64 bytes for the other endpoints.

The USB transceiver module is accessed through USB_Dp and USB_Dm pins.

Features

- Full Speed USB node
- Interfaces to USB V1.1 transceiver with programmable rise and fall times and integrated D+/D- pull-up resistors.
- Serial Interface Engine (SIE) consisting of a Media Access Controller (MAC), USB Specification 1.0 and 1.1 compliant
- USB Function Controller with seven FIFO-based Endpoints:
 - One bidirectional Control Endpoint 0 (8 bytes)
 - Three Transmit Endpoints (64 bytes each)
 - Three Receive Endpoints (64 bytes each)
- Automatic Data PID toggling/checking and NAK packet recovery (maximum 256 x32 bytes of data = 8 kB)

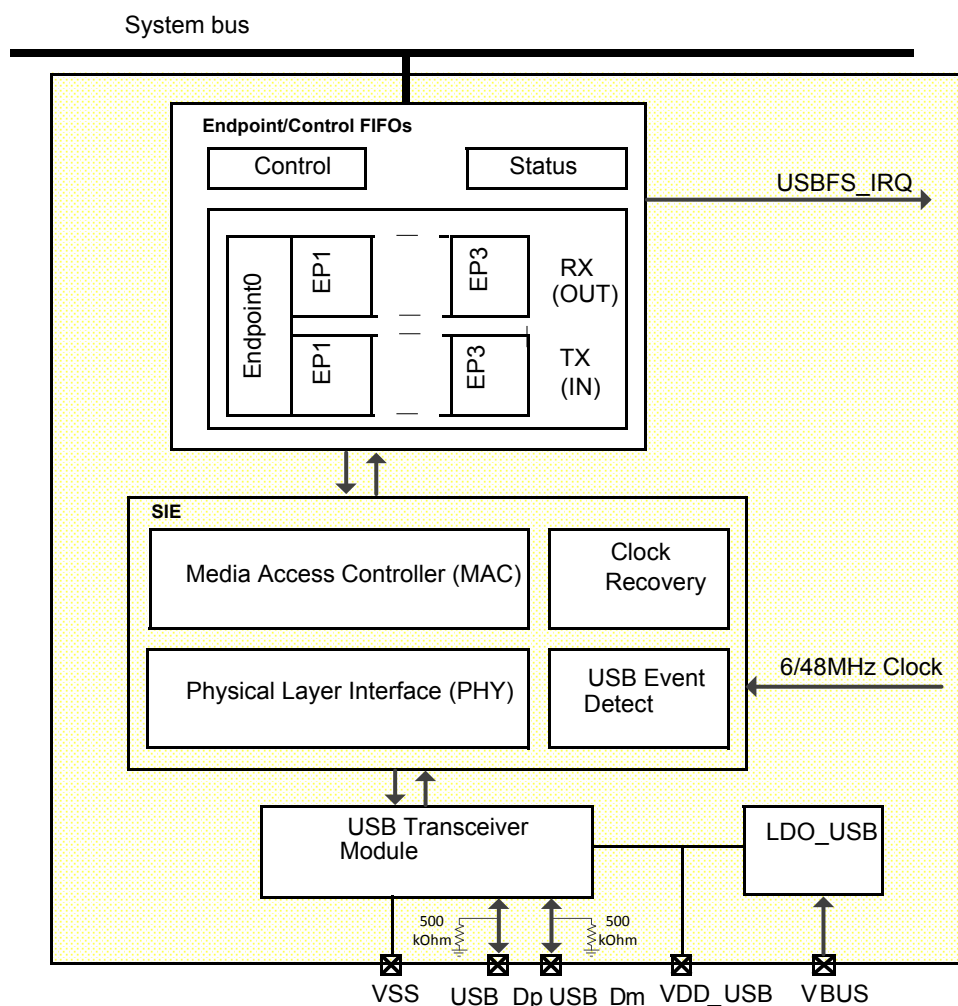

Figure 104: USB Node block diagram

31.1 SERIAL INTERFACE ENGINE

The SIE is comprised of physical (PHY) and Media Access Controller (MAC) modules. The PHY module includes the digital-clock recovery circuit, a digital glitch filter, End Of Packet (EOP) detection circuitry, and bit stuffing and unstuffing logic. The MAC module includes packet formatting, CRC generation and checking, and endpoint address detection. It provides the necessary control to give the NAK, ACK and STALL responses as determined by the Endpoint Pipe Controller (EPC) for the specified endpoint pipe. The SIE is also responsible for detecting and reporting USB-specific events, such as NodeReset, NodeSuspend and NodeResume. The module output signals to the transceiver are well matched (under 1 ns) to minimize skew on the USB signals.

The USB specifications assign bit stuffing and unstuffing as the method to ensure adequate electrical transitions on the line to enable clock recovery at the receiving end. The bit stuffing block ensures that whenever a string of consecutive 1's is encountered, a 0 is inserted after every sixth 1 in the data stream. The bit unstuffing logic reverses this process.

The clock recovery block uses the incoming NRZI data to extract a data clock (12 MHz FS, 1.5 MHz LS) from a 48 (FS) / 6(LS) MHz input clock. This clock is used in the data recovery circuit. The output of this block is binary data (decoded from the NRZI stream) which can be appropriately sampled using the extracted 12(6) MHz clock. The jitter performance and timing characteristics meet the requirements set forth in Chapter 7 of the USB Specification.

31.2 ENDPOINT PIPE CONTROLLER (EPC)

The EPC provides the interface for USB function endpoints. An endpoint is the ultimate source or sink of data. An endpoint pipe facilitates the movement of data between USB and memory, and completes the path between the USB host and the function endpoint. According to the USB specification, up to 31 such endpoints are supported at any given time. USB allows a total of 16 unidirectional endpoints for receive and 16 for transmit. As the control endpoint 0 is always bidirectional, the total number is 31. The Full/Low Speed USB node supports a maximum of seven endpoint pipes with the same function address. See [Figure 105](#): for a schematic diagram of EPC operation.

A USB function is a USB device that is able to transmit and receive information on the bus. A function may have one or more configurations, each of which defines the interfaces that make up the device. Each interface, in turn, is composed of one or more endpoints.

Each endpoint is an addressable entity on USB and is required to respond to IN and OUT tokens from the USB host (typically a PC). IN tokens indicate that the host has requested to receive information from an endpoint, and OUT tokens indicate that it is about to send information to an endpoint.

On detection of an IN token addressed to an endpoint, the endpoint pipe should respond with a data packet. If the endpoint pipe is currently stalled, a STALL handshake packet is sent under software control. If the endpoint pipe is enabled but no data is present, a NAK (Negative Acknowledgment) handshake packet is sent automatically. If the endpoint pipe is isochronous and enabled but no data is present, a bit stuff error followed by an end of packet is sent on the bus.

Similarly, on detection of an OUT token addressed to an endpoint, the endpoint pipe should receive a data packet sent by the host and load it into the appropriate FIFO. If the endpoint pipe is stalled, a STALL handshake packet is sent. If the endpoint pipe is enabled but no buffer is present for data storage, a NAK handshake packet is sent.

A disabled endpoint does not respond to IN, OUT, or SETUP tokens.

The EPC maintains separate status and control information for each endpoint pipe.

For IN tokens, the EPC transfers data from the associated FIFO to the host. For OUT tokens, the EPC transfers data in the opposite direction.

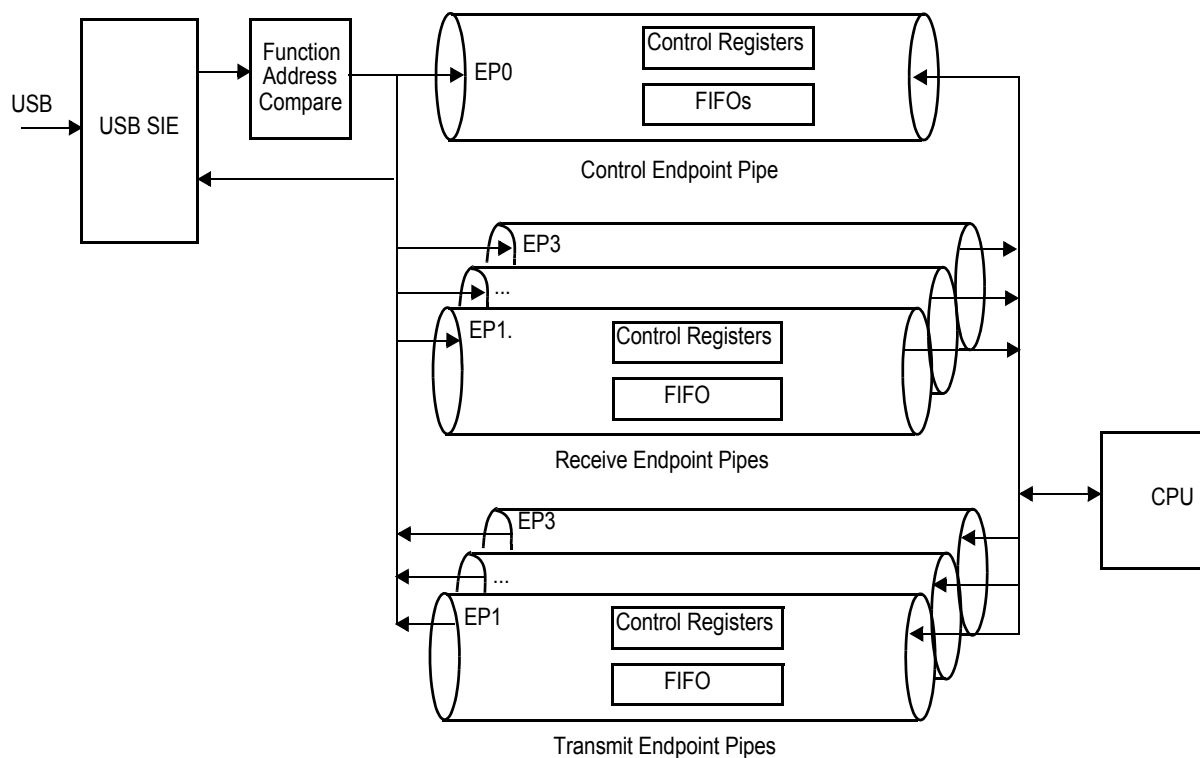

Figure 105: Endpoint Operation

31.3 FUNCTIONAL STATES

31.3.1 Line Condition Detection

At any given time, the USB node is in one of the following states (see "Functional states" on page 138 for the functional state transitions):

- **NodeOperational:** Normal operation
- **NodeSuspend:** Device operation suspended due to USB inactivity
- **NodeResume:** Device wake-up from suspended state
- **NodeReset:** Device reset

The NodeSuspend, NodeResume, or NodeReset line condition causes a transition from one operating state to another. These conditions are detected by specialized hardware and reported via the Alternate Event (ALTEV) register. If interrupts are enabled, an interrupt is generated upon the occurrence of any of the specified conditions.

NodeOperational State: This is the normal operating state of the node. In this state, the node is configured for operation on the USB.

NodeSuspend State: A USB node is expected to enter NodeSuspend state when 3 ms have elapsed without any detectable bus activity. The USB node looks for

this event and signals it by setting the SD3 bit in the USB_ALTEV register, which causes an USB_INT, if enabled, to be generated. The firmware should respond by putting the USB node in NodeSuspend state.

Refer to "" on page 147 on how to obtain to lowest power consumption in the NodeSuspend state.

The USB node can resume normal operation in two ways:

- **Host initiated.** By detecting a resume signalling followed by Low speed EOP on the USB bus, an ALTEV[RESUME] interrupt is generated. The firmware responds by setting the **NodeOperational** in the USB_NFRS_REG (See also section on page 147)
- **Device initiated.** By detection of a local event, e.g GPIO key is pressed, a KEYB_INT is generated. The firmware releases the USB node from NodeSuspend state by initiating a **NodeResume** on the USB using the NFRS register. The node firmware must ensure at least 5 ms of Idle on the USB, by checking the SD5 in the USB_ALTEV before going to the NodeResume state.

NodeResume State: In NodeResume state, a constant "K" is signalled on the USB. This should last for at least 1 ms and no more than 15 ms, after which the USB host should continue sending the NodeResume signal

for at least an additional 20 ms, and then completes the NodeResume operation by issuing the End Of Packet (EOP) sequence.

To successfully detect the EOP, the firmware must respond by setting **NodeOperational** in the USB_NFRS_REG. Upon detection on the EOP, the USB_ALTEV_REG[EOP] is set.

If no EOP is received from the host within 100 ms, the software must re-initiate NodeResume.

NodeReset: When detecting a NodeResume or NodeReset signal while in NodeSuspend state, the USB node can signal this to the CPU by generating an interrupt.

USB specifications require that a device must be ready to respond to USB tokens within 10 ms after wake-up or reset.

31.4 FUNCTIONAL STATE DIAGRAM

Figure 106 shows the device states and transitions, as well as the conditions that trigger each transition. All Full/Low Speed USB node state transitions are initiated by the firmware.

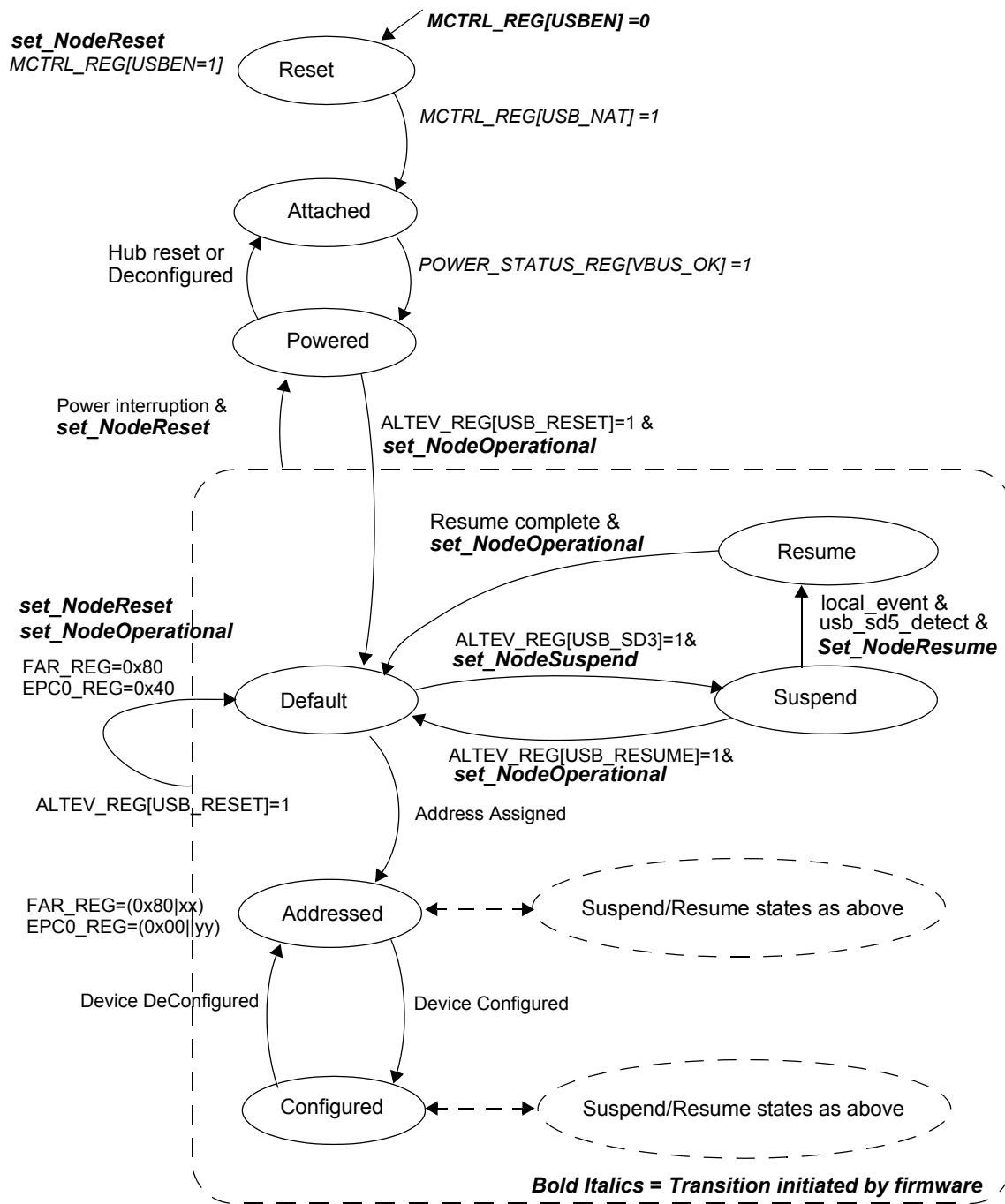

Figure 106: Node Functional State Diagram

Note 17: When the node is not in NodeOperational state, all registers are frozen with the exception of the endpoint controller state machines, and the TX_EN, LAST and RX_EN bits which are reset.

Note 18: In NodeResume state, resume signalling is propagated upstream.

Note 19: In NodeSuspend state, the node may enter a low power state and is able to detect resume signalling.

Table 52: Functional states

State Transition	Condition Asserted
set_NodeReset	Node Functional State register NFS[1:0] bits are written with 00 _b (The firmware should only initiate set_NodeReset if RESET in the ALTEV register is set.)
set_NodeSuspend	Node Functional State register NFS[1:0] bits are written with 11 _b The firmware should only initiate set_suspend if SD3 in the ALTEV register is set.
set_NodeOperation	Node Functional State register NFS[1:0] bits are written with 10 _b
set_NodeResume	Node Functional State register NFS[1:0] bits are written with 01 _b The firmware should only initiate clear_suspend if SD5 in the ALTEV register is set.
usb_reset_detect	USB_RESET in the ALTEV register is set to 1
local_event	A local event that should wake up the USB.
usb_sd5_detect	USB_SD5 in the ALTEV register is set to 1.
usb_suspend_detect	USB_SD3 in the ALTEV register is set to 1.
usb_resume_detect	RESUME in the ALTEV register is set to 1.
resume_complete	The node should stay in NodeResume state for at least 10 ms and then must enter USB Operational state to detect the EOP from the host, which terminates this Remote Resume operation. EOP is signalled when EOP in the ALTEV register is set to 1.

31.5 ADDRESS DETECTION

Packets are broadcast from the host controller to all the nodes on the USB network. Address detection is implemented in hardware to allow selective reception of packets and to permit optimal use of microcontroller bandwidth. One function address with seven different endpoint combinations is decoded in parallel. If a match is found, then that particular packet is received into the FIFO; otherwise it is ignored.

Figure 107 shows a block diagram of the function address and endpoint decoding. The incoming USB Token, Packet Address field and four bits Endpoint field are extracted from the incoming bit stream. The address field is compared to the Function Address register (FADR) and if a match is detected, the USB Endpoint field is compared to all EP bit fields in the Endpoint Control registers (EPCx). With IN tokens, the transmit Endpoint Control registers are compared and with OUT tokens the receive Endpoint Control registers are compared. A match then enables the respective endpoint FIFO and transfers the payload data to/from the FIFO. Note that EPC0 is bidirectional and is enabled for IN, OUT and SETUP tokens.

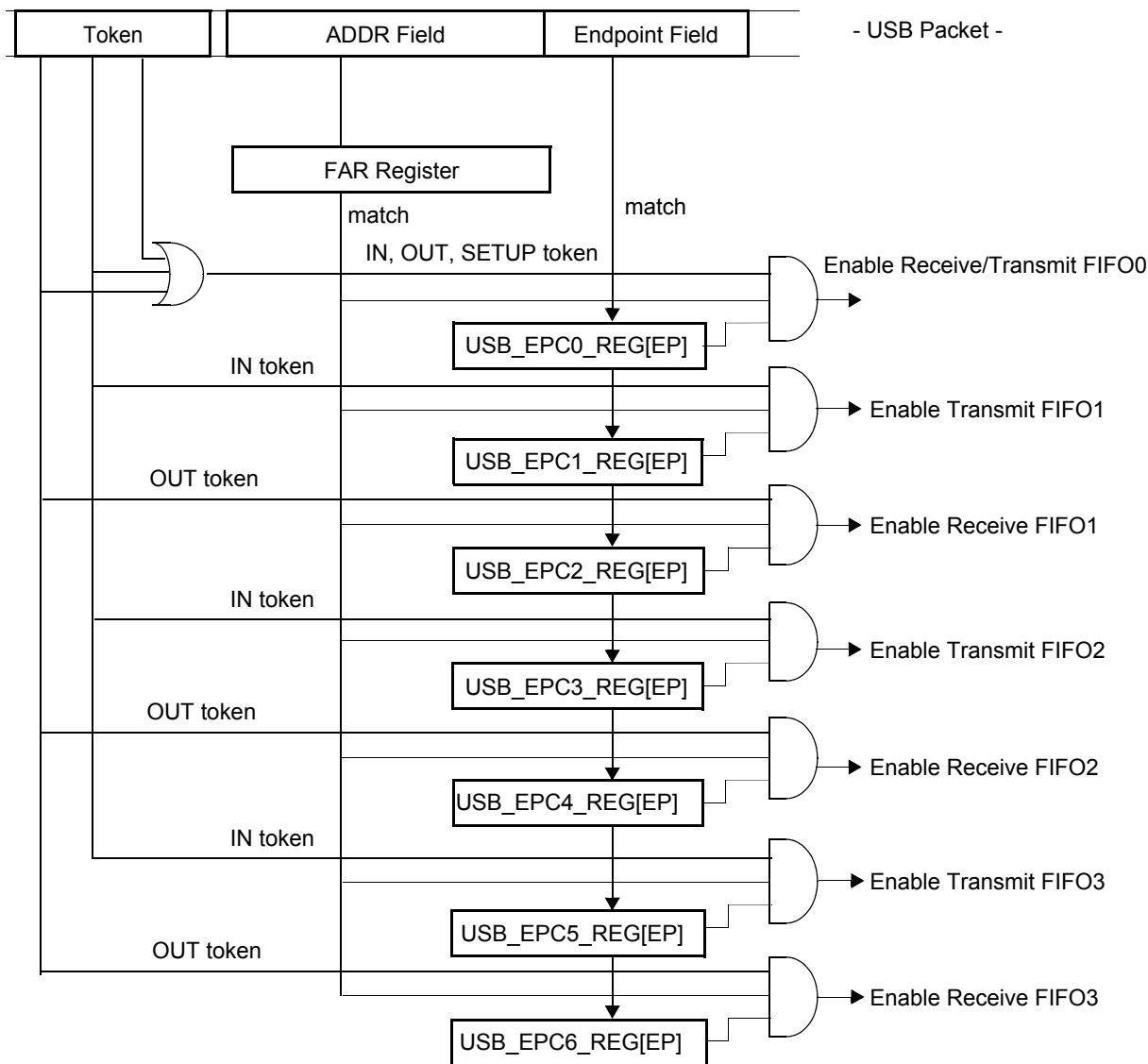

Figure 107: USB Function Address/Endpoint Decoding

31.6 TRANSMIT AND RECEIVE ENDPOINT FIFOS

The Full/Low Speed USB node uses a total of seven transmit and receive FIFOs: one bidirectional transmit and receive FIFO for the mandatory control endpoint, three transmit FIFOs and three receive FIFOs. As shown in Table 53, the bidirectional FIFO for the control endpoint is 8 bytes deep. The additional unidirectional FIFOs are 64 bytes each for both transmit and receive. Each FIFO can be programmed for one exclusive USB endpoint, used together with one globally decoded USB function address. The firmware must not enable both transmit and receive FIFOs for endpoint zero at any given time.

Table 53: USB Node Endpoint sizes

Endpoint No.	TX FIFO		RX FIFO	
	Size (Bytes)	Name	Size (Bytes)	Name
0	8 FIFO0			
1	64	TXFIFO1 (IN)		
2			64	RXFIFO1 (OUT)
3	64	TXFIFO2 (IN)		
4			64	RXFIFO2 (OUT)
5	64	TXFIFO3 (IN)		
6			64	RXFIFO3 (OUT)

If two endpoints in the same direction are programmed with the same endpoint number [EP field] and both are enabled, data is received or transmitted to/from the endpoint with the lower number, until that endpoint is disabled for bulk or interrupt transfers, or becomes full or empty for ISO transfers. For example, if receive EP1 and receive EP2 both use endpoint 3 and are both isochronous, the first OUT packet is received into EP1 and the second OUT packet into EP2, assuming no firmware interaction in between. For ISO endpoints, this allows implementing a ping-pong buffer scheme together with the frame number match logic.

Endpoints in different directions programmed with the same endpoint number operate independently.

31.7 BIDIRECTIONAL CONTROL ENDPOINT FIFO0

FIFO0 should be used for the bidirectional control endpoint zero. It can be configured to receive data sent to the default address with the DEF bit in the EPC0 register.

The Endpoint 0 FIFO can hold a single receive or transmit packet with up to 8 bytes of data.

Note: A packet written to the FIFO is transmitted if an IN token for the respective endpoint is received. If an error condition is detected, the packet data remains in the FIFO and transmission is retried with the next IN token.

The FIFO contents can be flushed to allow response to an OUT token or to write new data into the FIFO for the next IN token.

Figure 108 shows the Endpoint 0 state machine. In state TXWAIT, if USB_RXC0_REG[SETUP_FIX]=0, no state change will take place if a SETUP is received. With SETUP_FIX=1, the state machine goes to IDLE, flushes to EP0 and receives the token in the RXWAIT state. If a SETUP is received in states TXFILL or RXDRAIN and SETUP_FIX=1, the SETUP will be ignored and no ACK is send. This allows undisturbed FIFO filling/emptying. This state is usually present for a very short time and will force the host to retransmit the SETUP once.

If an OUT token is received for the FIFO, the firmware is informed that the FIFO has received data only if there was no error condition (CRC or STUFF error). Erroneous receptions are automatically discarded.

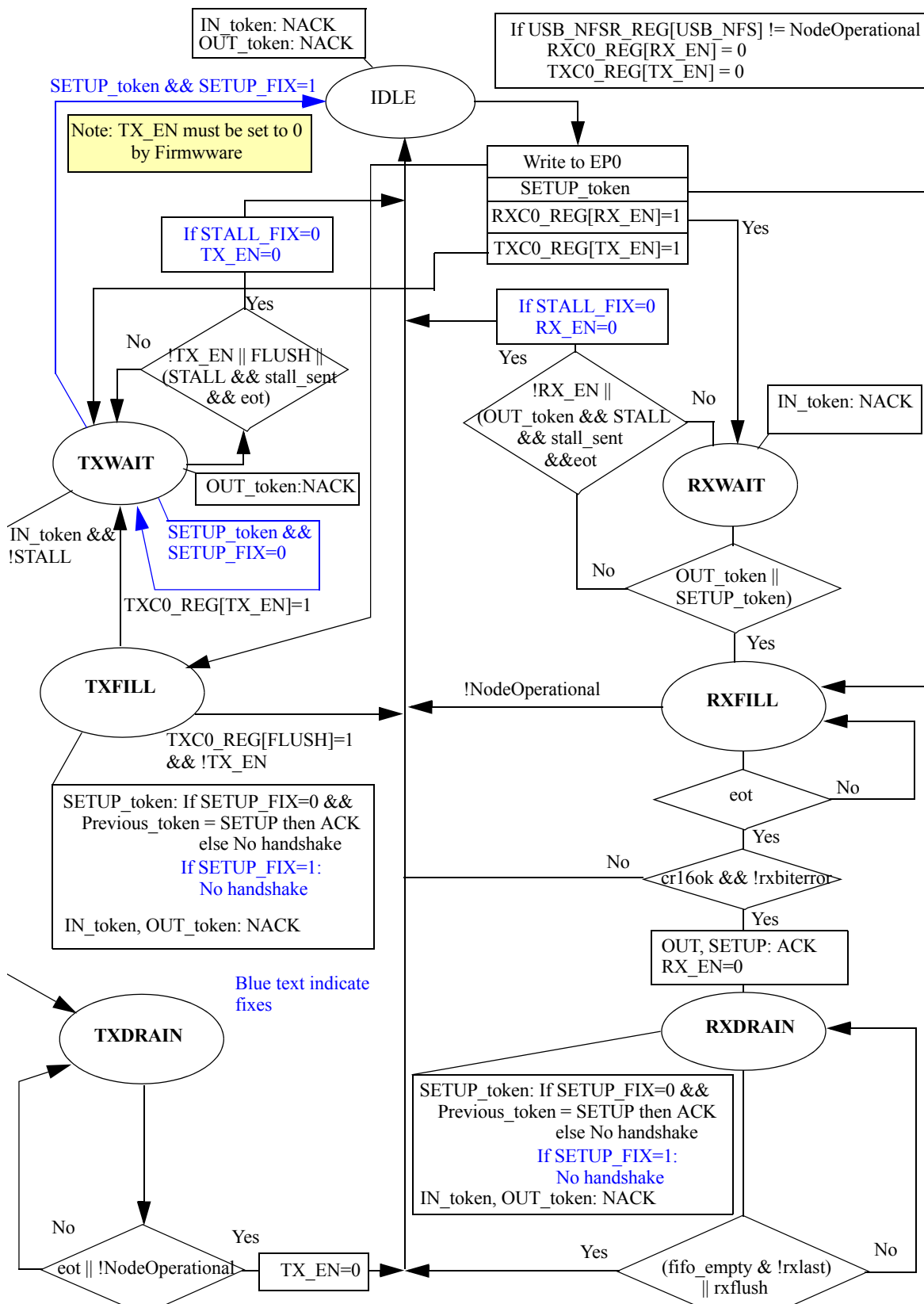

Figure 108: Endpoint 0 Operation

31.8 TRANSMIT ENDPOINT FIFO (TXFIFO1 TO TXFIFO5)

The Transmit FIFOs for Endpoints 1, 3 and 5 support bulk and interrupt USB packet transfers larger than the actual FIFO size. Therefore the firmware must update

the FIFO contents while the USB packet is transmitted on the bus.

Figure 109 illustrates the operation of the transmit FIFOs.

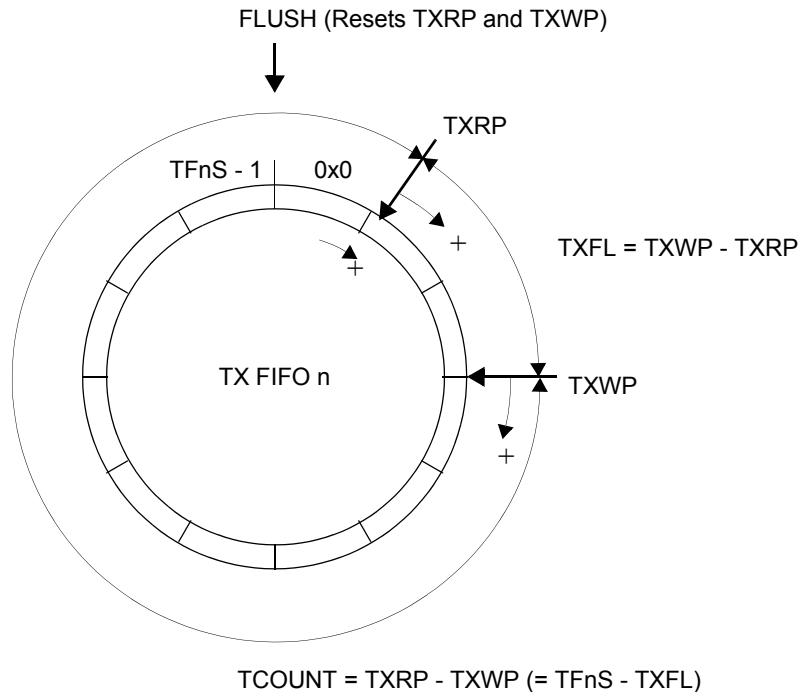

Figure 109: Tx FIFO operation

TFnS: Transmit FIFO n Size

This is the total number of bytes available within the FIFO.

TXRP: Transmit Read Pointer

This pointer is incremented every time the Endpoint Controller reads from the transmit FIFO. This pointer wraps around to zero if TFnS is reached. TXRP is never incremented beyond the value of the write pointer TXWP.

An underrun condition occurs if TXRP equals TXWP and an attempt is made to transmit more bytes when the LAST bit in the TXCMDx register is not set.

TXWP: Transmit Write Pointer

This pointer is incremented every time the firmware writes to the transmit FIFO. This pointer wraps around to zero if TFnS is reached.

If an attempt is made to write more bytes to the FIFO than actual space available (FIFO overrun), the write to the FIFO is ignored. If so, TCOUNT is checked for an indication of the number of empty bytes remaining.

TXFL: Transmit FIFO Level

This value indicates how many bytes are currently in the FIFO.

A FIFO warning is issued if TXFL decreases to a specific value. The respective WARNn bit in the FWR register is set if TXFL is equal to or less than the number specified by the TFWL bit in the TXCn register.

TCOUNT: Transmit FIFO Count

This value indicates how many empty bytes can be filled within the transmit FIFO. This value is accessible by firmware via the TXSn register.

31.9 RECEIVE ENDPOINT FIFO (RXFIFO2 TO RXFIFO6)

The Receive FIFOs for the Endpoints 2, 4 and 6 support bulk, interrupt USB packet transfers larger than the actual FIFO size. If the packet length exceeds the FIFO size, the firmware must read the FIFO contents while the USB packet is being received on the bus.

Figure 110 illustrates the operation of the Receive FIFOs.

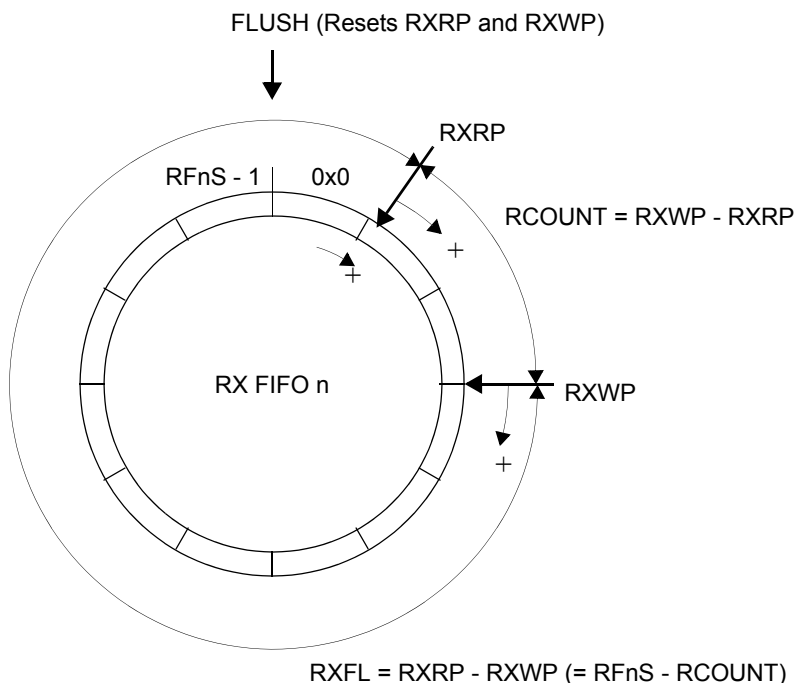

Figure 110: Rx FIFO operation

RFnS: Receive FIFO n Size

This is the total number of bytes available within the FIFO.

RXRP: Receive Read Pointer

This pointer is incremented with every read of the firmware from the receive FIFO. This pointer wraps around to zero if RFnS is reached. RXRP is never incremented beyond the value of RXWP.

If an attempt is made to read more bytes than are actually available (FIFO underrun), the last byte is read repeatedly.

RXWP: Receive Write Pointer

This pointer is incremented every time the Endpoint Controller writes to the receive FIFO. This pointer wraps around to zero if RFnS is reached.

An overrun condition occurs if RXRP equals RXWP and an attempt is made to write an additional byte.

RXFL: Receive FIFO Level

This value indicates how many more bytes can be received until an overrun condition occurs with the next write to the FIFO.

A FIFO warning is issued if RXFL decreases to a specific value. The respective WARNn bit in the FWR register is set if RXFL is equal to or less than the number specified by the RFWL bit in the RXCn register.

RCOUNT: Receive FIFO Count

This value indicates how many bytes can be read from the receive FIFO. This value is accessible by firmware via the RXSn register.

31.10 INTERRUPT HIERARCHY

Figure 111 shows the register hierarchy for generating USB interrupt events. Each bit in the event register can be masked with by setting the corresponding bit in the xxxMSK_REG. A USBFS_IRQ to the CPU is generated if one or more bits in the MAEV_REG are set and the corresponding bits in the MAMSK_REG are set to '1'. Bit 7 in the MAMSK_REG is a global interrupt enabled for the USBFS_IRQ.

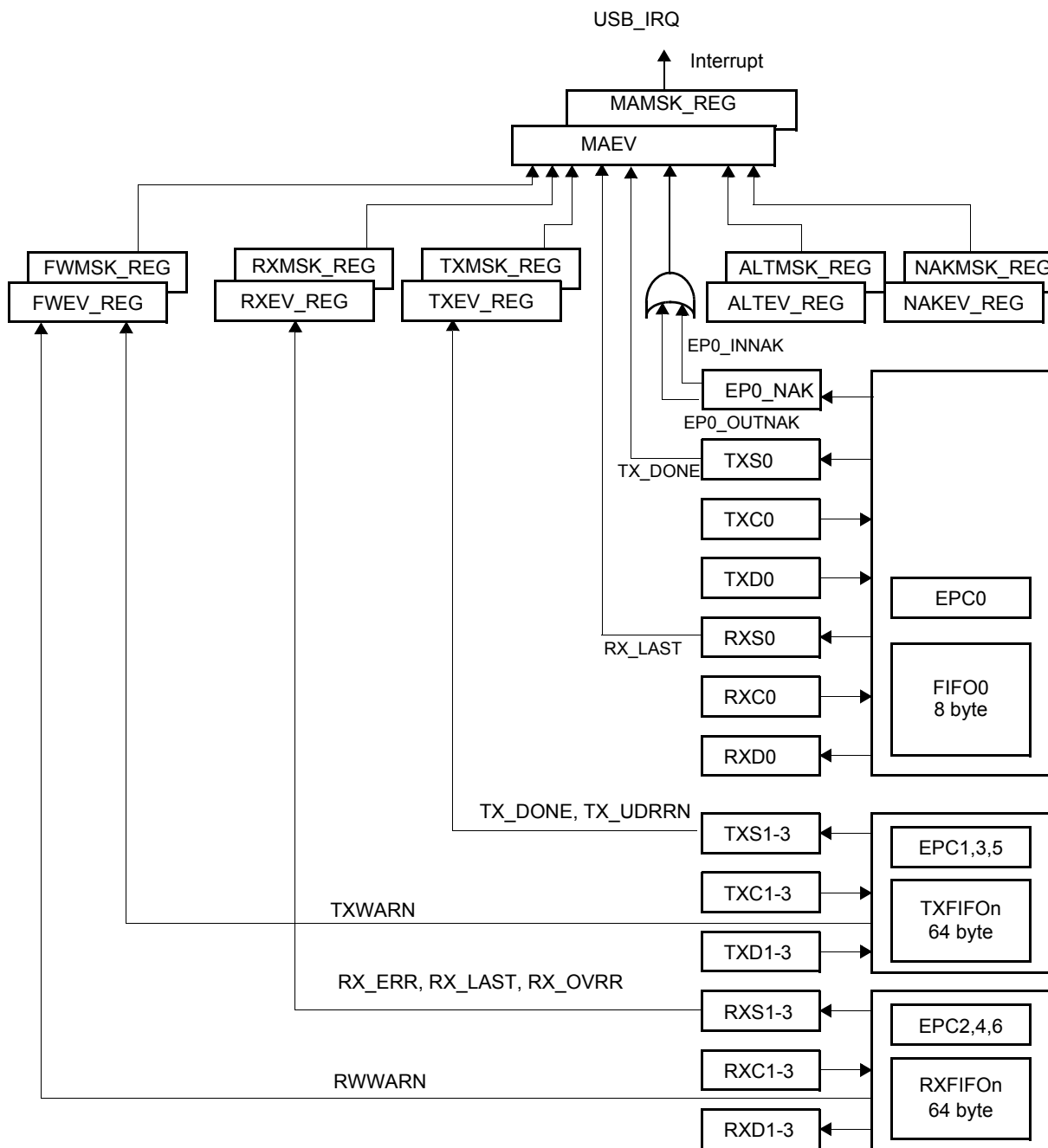

Figure 111: Interrupt Register hierarchy

32 Input/Output ports

The DA14681 has software-configurable I/O pin assignment, organized into ports Port 0, Port 1, Port 2, Port 3 and Port 4. Only ports 0, 1 and 2 are available at the WLCSP package. All ports are available at the QFN60 package.

Features

- Port 0: 8 pins, Port 1: 8 pins, Port 2: 5 pins, Port 3: 8 pins, Port 4: 8 pins
- Fully programmable pin assignment

- Selectable 25 k Ω pull-up, pull-down resistors per pin
- Programmable open-drain functionality
- Pull-up to V33 or VDD1V8 (depends on selection)
- Fixed assignment for analog pins ADC[7:0], QSPI and SDW
- Pins retain their last state when system enters the Sleep or Deep Sleep mode.
- P0_6 is kept powered while in Extended Sleep controlled by Timer1 PWM5 signal

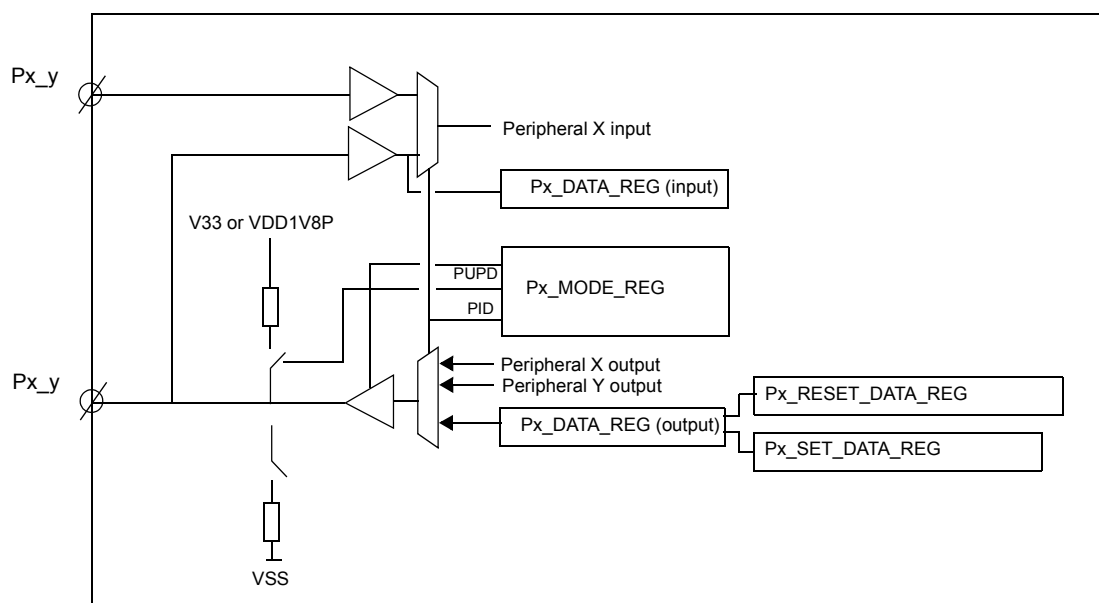

Figure 112: Port P0, P1, P2, P3 and P4 with Programmable Pin Assignment

32.1 PROGRAMMABLE PIN ASSIGNMENT

The Programmable Pin Assignment (PPA) provides a multiplexing function to the I/Os of on-chip peripherals. Any peripheral input or output signal can be freely mapped to any I/O port bit by setting Pxy_MODE_REG[4-0].

Refer to the Px_MODE_REGS for an overview of the available PIDs. Analog ADC has fixed pin assignment in order to limit interference with the digital domain. The SWD interface (JTAG) is mapped on P0_6 and P2_4.

The firmware has the possibility to assign the same peripheral output to more than one pin. It is the responsibility of the user to make a unique assignment.

In case more than one input signal is assigned to a peripheral input, the left most pin in the lowest port pin number has priority. (e.g P00_MODE_REG has priority over P01_MODE_REG)

The port direction is controlled by setting:

Pxy_MODE_REG[9:8]

- 00 = Input, no resistors selected
- 01 = Input, pull-up selected
- 10 = Input, pull-down selected
- 11 = Output, no resistors selected

In output mode and analog mode the pull-up/down resistors are automatically disabled.

32.2 GENERAL PURPOSE PORT REGISTERS

The general purpose ports are selected with PID=0. The port function is accessible through registers:

- Px_DATA_REG: Port data input/output register
- Px_SET_OUTPUT_DATA_REG: Port set output register
- Px_RESET_OUTPUT_DATA_REG: Port reset output register

32.2.1 Port Data Register

The registers input Px_DATA_REG and output Px_DATA_REG are mapped on the same address.

The data input register (Px_DATA_REG) is a read-only

register that returns the current state on each port pin even if the output direction is selected, regardless of the programmed PID, unless the analog function is selected (in this case it reads 0). The ARM CPU can read this register at any time even when the pin is configured as an output.

The data output register (Px_DATA_REG) holds the data to be driven on the output port pins. In this configuration, writing to the register changes the output value.

32.2.2 Port Set Data Output Register

Writing an 1 in the set data output register (Px_SET_DATA_REG) sets the corresponding output pin. Writing a 0 is ignored.

32.2.3 Port Reset Data Output Register

Writing a 1 in the reset data output register (Px_RESET_DATA_REG) resets the corresponding output pin. Writing a 0 is ignored.

32.3 FIXED ASSIGNMENT FUNCTIONALITY

There are certain signals that have a fixed mapping on specific general purpose IOs. This assignment is illustrated in the following table:

Table 54: Fixed Assignment of Specific Signals

GPIO	SWD	QSPI	ADC	PWM
P0_0		QSPI_CLK		
P0_1		QSPI_D0		
P0_2		QSPI_D1		
P0_3		QSPI_D2		
P0_4		QSPI_D3		
P0_5		QSPI_CS		
P0_6	SWDIO		ADC_4	PWM5 (only in Sleep mode)
P0_7			ADC_3	
P1_0			ADC_5	
P1_1				
P1_2			ADC_0	
P1_3			ADC_2	
P1_4			ADC_1	
P1_5			ADC_6	
P1_6				
P1_7				
P2_3				
P2_4	SW_CLK		ADC_3	

32.4 STATE RETENTION WHILE SLEEPING

Before setting the system to any of the sleep modes, the state of the pads needs to be retained so that no external components are affected by GPIOs changing state when the system goes to sleep, but also to avoid any floating driving signals from power domains that are shut off leading to increasing power dissipation.

The state of the pads is automatically latched by always-on latches by setting the PAD_LATCH_EN bit in the SYS_CTRL_REG. This bit will latch all digital control signals going into the pad as well as the data output, hence if the pad was set as an output driving high, it will retain its precise state.

The signals in red in the following figures are latched:

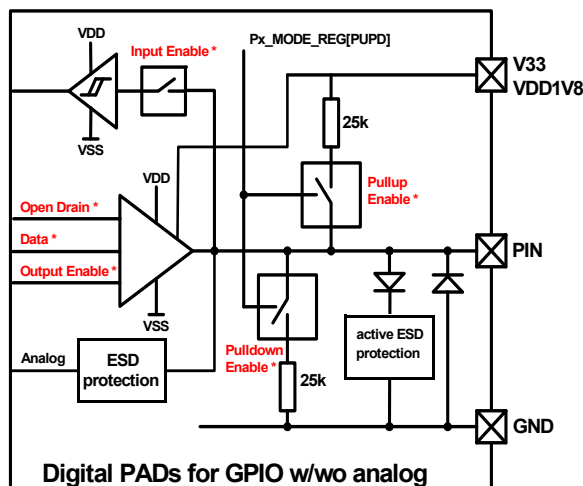

Figure 113: Latching of digital pad signals

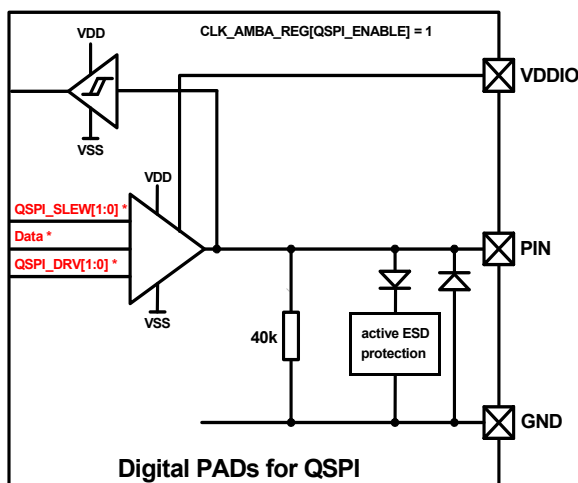

Figure 114: Latching of QSPI pad signals

After waking up, the software must ensure disabling of

the latching by de-asserting the PAD_LATCH_EN bit so that all pads are accessible and controllable again.

In the case of the QSPI pads, the pad latching will be overwritten by the QSPI controller as soon as the clock of the controller is enabled.

32.5 SPECIAL I/O CONSIDERATIONS

There are certain considerations in using the GPIOs as explained below:

- To use P1_1 or P2_2 in GPIO mode, USBPAD_REG[USBPAD_EN] must be set. However, the allowed levels on this pins are 0V and the voltage on V33 rail. If 1.8V is selected as the pin supply, then a current of 150 uA is to be expected. Moreover, these pins should not be used in sleep modes because the USBPAD_REG will be powered off (belongs to the peripheral power domain).
- P1_0, P1_5 and P1_7 might affect radio performance if toggling while RF activity. It is recommended to use them at low speed and not while radio is active.

33 BLE Core

The BLE (Bluetooth Low Energy) core is a qualified Bluetooth 4.2 baseband controller compatible with Bluetooth Low Energy specification and it is in charge of packet encoding/decoding and frame scheduling.

Features

- Bluetooth Low Energy compliant according to the specification of the Bluetooth System, v4.2, Bluetooth SIG.
 - Dual Topology
 - Low duty cycle advertising
 - L2CAP connection oriented channels
- All device classes support (Broadcaster, Central, Observer, Peripheral)
- All packet types (Advertising / Data / Control)
- Dedicated Encryption (AES / CCM)
- Bit stream processing (CRC, Whitening)
- FDMA / TDMA / events formatting and synchronization
- Frequency Hopping calculation
- Operating clock 16 or 8 MHz.
- Low power modes supporting 32.0 kHz, 32.768 kHz or 11.7 kHz
- Supports power down of the baseband during the protocol's idle periods.
- AHB Slave interface for register file access.
- AHB Slave interface for Exchange Memory access of CPU via BLE core.
- AHB Master interface for direct access of BLE core to Exchange Memory space

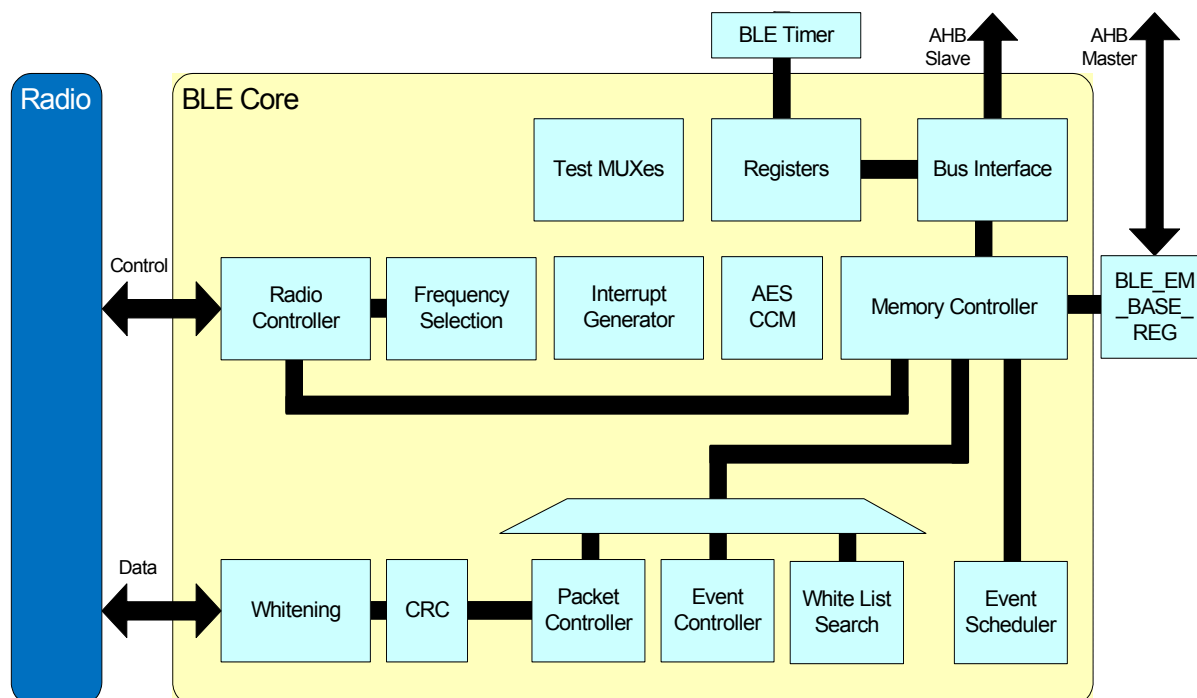

Figure 115: BLE Core Block Diagram

33.1 ARCHITECTURE

33.1.1 Exchange Memory

The BLE Core requires access to a memory space named “Exchange Memory” to store control structures and frame buffers. The access to Exchange Memory is performed via the AHB Master interface. The base address of the Exchange Memory is programmable by means of the BLE_EM_BASE register. The maximum addressable size of the BLE core is 64 kB.

33.2 PROGRAMMING

33.2.1 Wake up IRQ

Once BLE core switches to “BLE Deep Sleep Mode” the only way to correctly exit from this state is by initially generating the BLE_WAKEUP_LP_IRQ and consecutively the BLE_SLP_IRQ. This sequence must be followed regardless of the cause of the termination of the “BLE Deep Sleep Mode”, i.e. either when if the BLE Timer expired or BLE Timer has been stopped due to the assertion of BLE_WAKEUP_REQ.

The assertion and de-assertion of BLE_WAKEUP_LP_IRQ is fully controlled via the BLE_ENBPRESET_REG bit fields. Detailed description is following:

TWIRQ_SET: Number of “ble_lp_clk” cycles before the expiration of the BLE Timer, when the BLE_WAKEUP_LP_IRQ will be asserted. It is recommended to select a TWIRQ_SET value larger than the time required for the XTAL16_TRIM_READY_DELAY event, plus the IRQ Handler execution time. If the programmed value of TWIRQ_SET is less than the minimum required value, then the actual BLE sleep duration (refer to BLE_DEEPSLSTAT_REG) will be larger than the programmed sleep duration (refer to BLE_DEEPSLWKUP_REG).

TWIRQ_RESET: Number of “ble_lp_clk” cycles before the expiration of the sleep period, when the BLE_WAKEUP_LP_IRQ will be de-asserted. It is recommended to always set to “1”.

TWEXT: Determines the high period of BLE_WAKEUP_LP_IRQ, in the case of an external wake up event (refer to GP_CONTROL_REG[BLE_WAKEUP_REQ]). Minimum value is “TWIRQ_RESET + X”, where X is the number of “ble_lp_clk” clock cycles that BLE_WAKEUP_LP_IRQ will be held high. Recommended value is “TWIRQ_RESET + 1”. Note that as soon as GP_CONTROL_REG[BLE_WAKEUP_REQ] is set to “1” the BLE_WAKEUP_LP_IRQ will be asserted.

Minimum BLE Sleep Duration: The minimum value of BLE_DEEPSLWKUP_REG[DEEPSLTIME] time, measured in “ble_lp_clk” cycles, is the maximum of (a) “TWIRQ_SET + 1” and (b) the SW execution time from setting BLE_DEEPSLCTL_REG[DEEP_SLEEP_ON]

up to preparing CPU to accept the BLE_WAKEUP_LP_IRQ (i.e. to call the ARM instruction WFI). If programmed DEEPSLTIME is less than the aforementioned minimum value, then BLE_WAKEUP_LP_IRQ Handler may execute sooner than the call of ARM WFI instruction for example, causing SW instability.

33.2.2 Switch from Active Mode to Deep Sleep Mode

Software can set the BLE core into the “BLE Deep Sleep Mode”, by first programming the timing of BLE_WAKEUP_LP_IRQ generation in BLE_ENBPRESET_REG, then program the desired sleep duration at BLE_DEEPSLWKUP_REG and finally set the register bit BLE_DEEPSLCTL_REG[DEEP_SLEEP_ON]. The BLE Core will switch to the “ble_lp_clk” (32.0kHz or 32.768 kHz) in order to maintain its internal 625us timing reference. Software must poll the state of BLE_CNTL2_REG[RADIO_PWRDN_ALLOW] to detect the completion of this mode transition. Once the mode transition is completed, SW must disable the BLE clocks (“ble_master1_clk”, “ble_master2_clk” and “ble_crypt_clk”) by setting to “0” the CLK_RADIO_REG[BLE_ENABLE] register bit. Finally, SW can optionally power down the BLE power domain by using the PMU_CTRL_REG[RADIO_SLEEP] and the Peripheral and System power domains as well.

Figure 116 presents the waveforms while entering in BLE Deep Sleep Mode. In this case, SW, as soon as it detects that RADIO_PWRDOWN_ALLOW is “1”, it sets the PMU_CTRL_REG[BLE_SLEEP] to power down the BLE domain. At the following figures, the corresponding BLE Core signals are marked with red while BLE domain is in power down state.

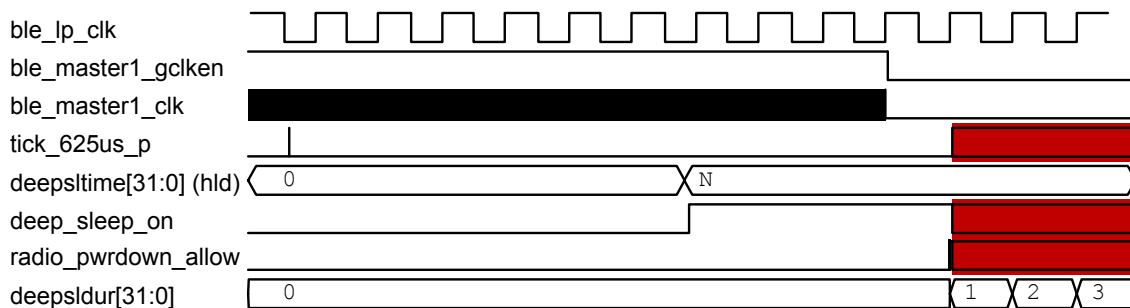

Figure 116: Entering into BLE Deep Sleep Mode

33.2.3 Switch from Deep Sleep Mode to Active Mode

There are two possibilities for BLE Core to terminate the BLE Deep Sleep mode:

1. Termination at the end of a predetermined time.
2. Termination on software wake-up request, due to an external event.

33.2.4 Switching on at anchor points.

Figure 119 shows a typical deep sleep phase that is terminated at predetermined time. After a configurable time before the scheduled wake up time (configured via BLE_ENBPRESET_REG register bit fields), the BLE Timer asserts the BLE_WAKEUP_LP_IRQ in order to wake-up the CPU (powering up the System Power Domain). The BLE_WAKEUP_LP_IRQ Interrupt

Handler will prepare the code environment and the XTAL 16MHz stabilization (refer to SYS_STAT_REG[XTAL16_SETTLED]) and will decide when the BLE Core will be ready to exit from the BLE Deep Sleep Mode.

Once the SW decides that BLE Core can wake up, it must enable the BLE clocks (via CLK_RADIO_REG[BLE_ENABLE]) and power up the BLE Power Domain (refer to PMU_CTRL_REG[BLE_SLEEP] and SYS_STAT_REG[BLE_IS_UP]).

After the expiration of the sleep period (as specified in BLE_DEEPSLWKUP_REG[DEEPSLTIME]) the BLE Timer will not exit the BLE Deep Sleep mode until it will

detect that BLE Core is powered up. That means that if the SW requires more time to power up the BLE Core, then the final sleep duration (provided by BLE_DEEPSLSTAT_REG) will be larger than the pre-programmed value.

When BLE Timer is expired, BLE clocks are enabled and BLE Core is powered up, the BLE Core exits the "BLE Core Deep Sleep mode" and asserts the BLE_SLP_IRQ.

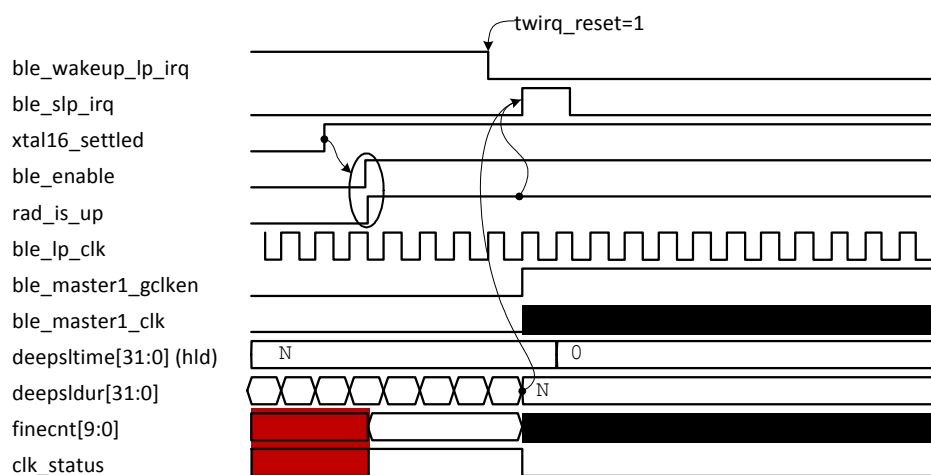

Figure 117: Exit BLE Deep Sleep Mode at predetermined time (zoom in)

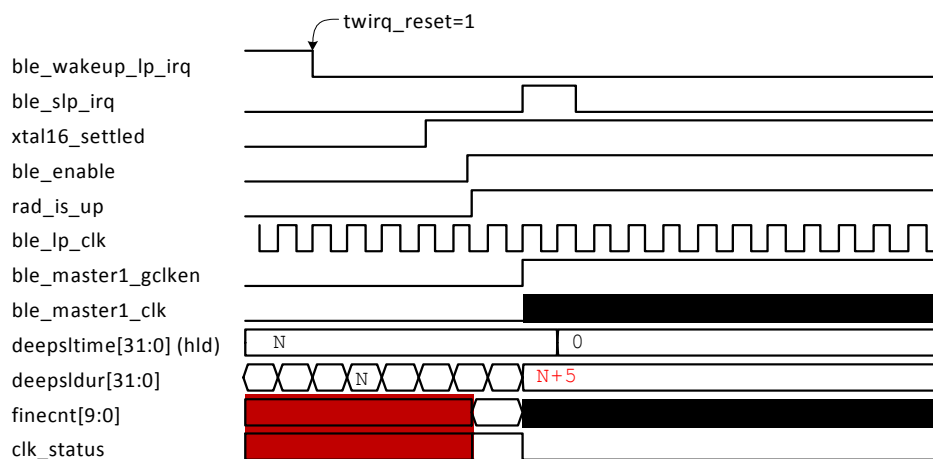

Figure 118: Exit BLE Deep Sleep Mode later than the predetermined time (zoom in)



Figure 119: Exit BLE Deep Sleep Mode at predetermined time (zoom out)

33.2.5 Switching on due to an external event.

Figure 120 shows a wake up from a deep sleep period forced by the assertion of register bit GP_CONTROL_REG[BLE_WAKEUP_REQ].

Assume that the system is in Deep Sleep state, i.e. all Power Domains have been switched off, and both the Wakeup Timer and Wakeup Controller have been programmed appropriately. Then assume that an event is detected at one of the GPIOs. In that case, the SW will decide to wake-up the BLE core, and will set the GP_CONTROL_REG[BLE_WAKEUP_REQ] to “1” in order to force the wake up sequence.

At Figure 120 the BLE_WAKEUP_REQ has been asserted by SW as soon as possible, causing BLE_WAKEUP_LP_IRQ Handler to be executed as soon as possible. It is also possible to postpone the assertion of BLE_WAKEUP_REQ to occur after the detection of XTAL16_TRIM_READY, causing both BLE_WAKEUP_LP_IRQ and BLE_SLP_IRQ Handlers to execute sequentially. The decision depends on the software structure and the application.

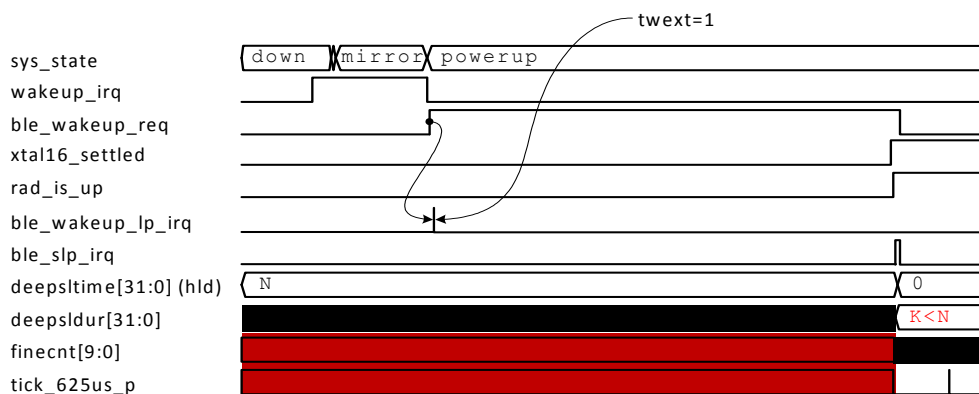

Figure 120: Exit BLE Deep Sleep Mode due to external event

As soon as bit field BLE_WAKEUP_REQ is set to “1” the BLE_WAKEUP_LP_IRQ will be asserted. In that case, the high period of BLE_WAKEUP_LP_IRQ is controlled via TWEXT. The recommended value of TWEXT is "TWIRQ_RESET + 1", meaning that BLE_WAKEUP_LP_IRQ will remain high for one “ble_lp_clk” period.

As long as the BLE_WAKEUP_REQ is high, entering the sleep mode is prohibited. Please note that BLE_WAKEUP_REQ event can be disabled by setting BLE_DEEPSLCNTL_REG[EXTWKUPDSB].

33.3 DIAGNOSTIC SIGNALS

The BLE core provides several internal signals that can be mapped out on GPIOs to provide more insight on the real time operation. They can also be used for controlling external Front End Modules (FEMs) (e.g. as explained in [Figure 127](#)). These signals are named as BLE diagnostics (ble_diagx).

There are 8 fixed ports that can be assigned BLE diagnostic signals as presented in the following table:

Table 55: BLE diagnostics mapping on GPIOs

BLE Diagnostics Port	GPIO port
ble_diag0	P2_0
ble_diag1	P2_1
ble_diag2	P2_2
ble_diag3	P1_0

Table 55: BLE diagnostics mapping on GPIOs

BLE Diagnostics Port	GPIO port
ble_diag4	P1_1
ble_diag5	P1_2
ble_diag6	P1_3
ble_diag7	P2_3

There are 3 different configuration schemes which allow for specific internal signals to be mapped on the BLE Diagnostics Port. These are configured by programming the BLE_DIAGCNTLx_REG registers with specific values. The assignment of the internal signals on the diagnostic port depending on the configuration is presented in the following table:

Table 56: BLE diagnostic signals per configuration

Registers value	Diagnostics Port	BLE signal	Description
BLE_DIAGCNTL_REG = 0x83838383 BLE_DIAGCNTL2_REG = 0x83838383 BLE_DIAGCNTL3_REG = 0x76543210	ble_diag0	radcntl_txen	Radio controller Tx enable signal
	ble_diag1	radcntl_rxen	Radio controller Rx enable signal
	ble_diag2	sync_window	Defines the correlation window for the access address. See timing in Figure 121
	ble_diag3	sync_found_pulse	Access address detection pulse. Will be generated only if correlation is successful. See timing in Figure 121
	ble_diag4	event_in_process	Indicates that an BLE event is currently in process. See timing in Figure 127
	ble_diag5	ble_event_irq	A pulse designating the end of Advertising/Scanning/Connection events
	ble_diag6	ble_rx_irq	A pulse designating that a packet is received depending on the configuration
	ble_diag7	ble_error_irq	A pulse indicating that the BLE core and the CPU are trying to access the same memory space at the same time
BLE_DIAGCNTL_REG = 0x92929292 BLE_DIAGCNTL2_REG = 0x92929292 BLE_DIAGCNTL3_REG = 0x76543210	ble_diag0	rx_data	BLE packet controller RX data bit
	ble_diag1	rx_data_en	BLE packet controller RX data bit qualifier
	ble_diag2	rx_data_core	BLE bit streaming RX data bit. Bit streaming engine consists of CRC and Whitening
	ble_diag3	rx_data_core_en	BLE bit streaming RX data bit qualifier
	ble_diag4	tx_data	BLE packet controller TX data bit
	ble_diag5	tx_data_en	BLE packet controller TX data bit qualifier
	ble_diag6	tx_data_core	BLE bit streaming TX data bit.
	ble_diag7	tx_data_core_en	BLE bit streaming TX data bit qualifier

The sync_window and sync_found_pulse timing is presented in the following figure:

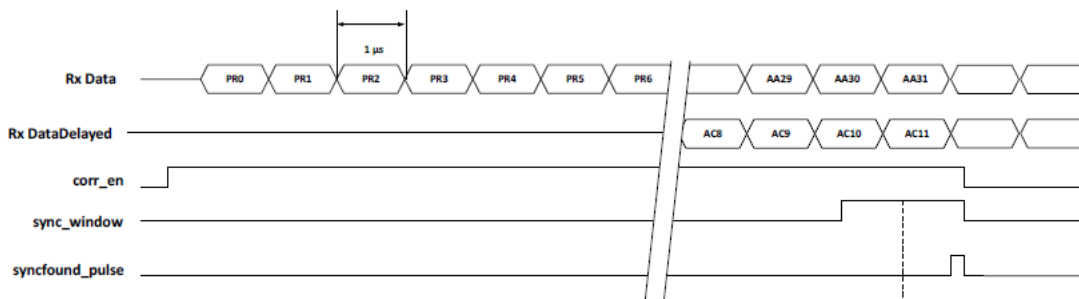

Figure 121: Diagnostics signals timing during correlation

33.4 POWER PROFILE

This section presents the current profile of the DA14681 when operating in the respective protocol mode as described in the following sections.

33.4.1 Advertising Event

The current profile of a Bluetooth Advertising event is presented in the following figure:

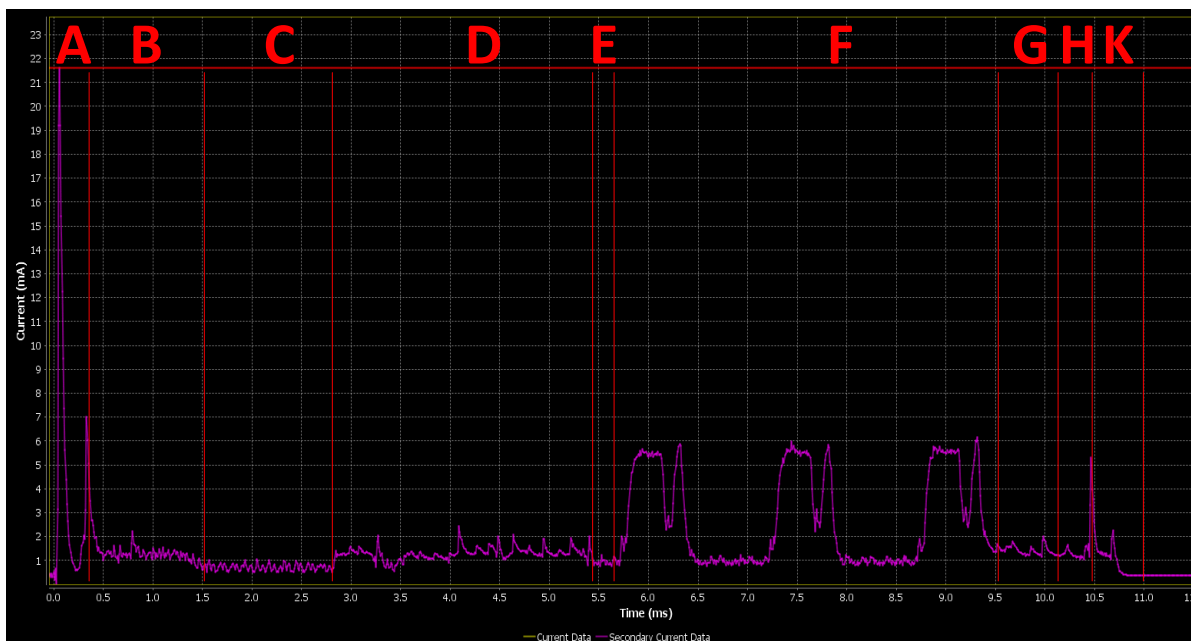

Figure 122: BLE Advertising power profile

The current profile figure is divided into sections which represent different operations within the DA14681 SoC. They are presented and explained in the following table:

Table 57: BLE Advertising profile breakdown

Section	Description	Time (μ s)
A	Startup process	500
B	XTAL16M initial time	1000
C	XTAL16M settling time	1400
D	Switched to XTAL16, BLE core is enabled	2600
E	WFI until the Radio starts	250
F	Radio activity (TX/RX) on channels 37, 38 and 39 ¹	3800
G	BLE core sleep preparation	400
H	OS sleep preparation	350

Table 57: BLE Advertising profile breakdown

Section	Description	Time (μ s)
K	Goto sleep process	400

¹ Time between RX/TX on successive channels is 1.5 ms

The overall charge required for this operation at 3V is 20 μ C while executing code from FLASH and ROM (cached mode). The Advertising interval is 600 ms. Note, that overall time might vary depending on the protocol's parameters.

33.4.2 Connection Event

The current profile of a Bluetooth Connection event is presented in the following figure:

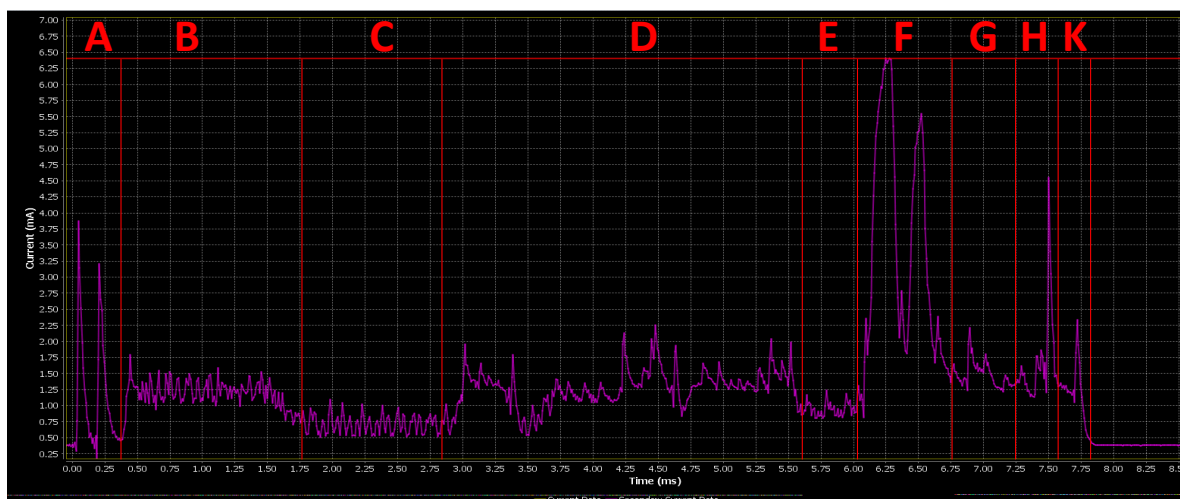

Figure 123: BLE Connection power profile

The current profile figure is divided into sections which represent different operations within the DA14681 SoC. They are presented and explained in the following table:

Table 58: BLE Connection profile breakdown

Section	Description	Time (μ s)
A	Startup process	500
B	XTAL16M initial time	1300
C	XTAL16M settling time	1150
D	Switched to XTAL16, BLE core is enabled	2600
E	WFI until the Radio starts	450

Table 58: BLE Connection profile breakdown

Section	Description	Time (μ s)
F	Radio activity (RX, TX)	500
G	BLE core sleep preparation	400
H	OS sleep preparation	350
K	Goto sleep process	400

The overall charge required for this operation at 3V is 10.6 μ C while executing code from FLASH and ROM (cached mode). The Connection interval is 30 ms. Note, that overall time might vary depending on the protocol's parameters.

34 CoEx interface

The DA14681 implements a coexistence interface for signalling radio activity to external 2.4 GHz co-located devices. A three wire interface is delivering information on the priority and the RF transmit/receive events.

The CoEx interface and its connection to the rest of the system is displayed in [Figure 124](#).

Features

- 2.4 GHz Radio activity indication
- Priority indication
- Sensing of external module RF activity
- Supports up to 2 external 2.4 GHz devices

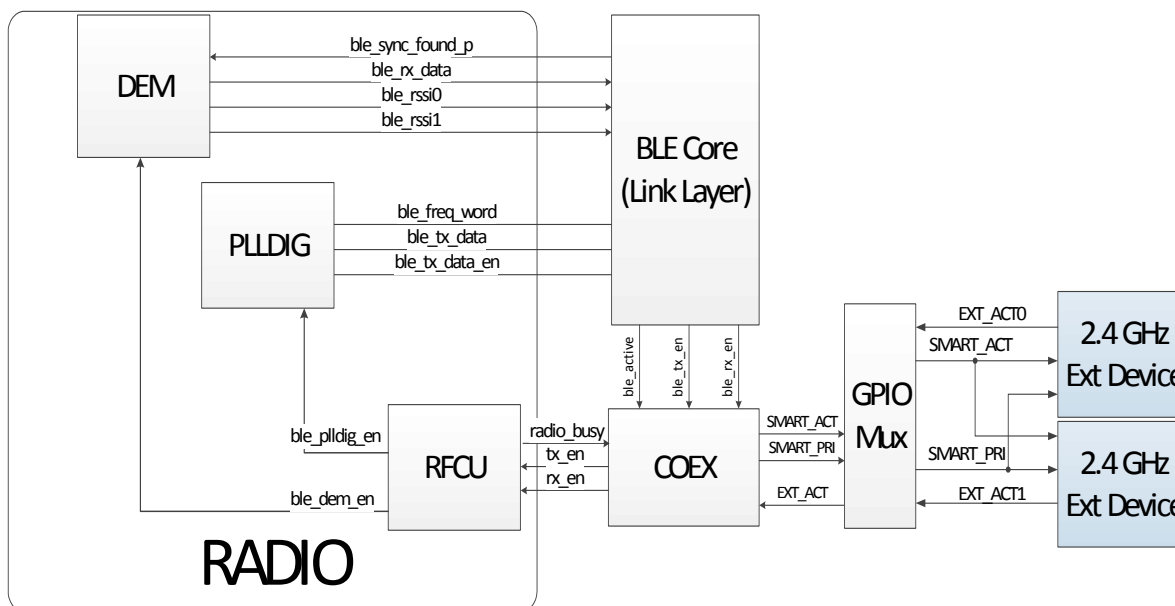

Figure 124: Coexistence interface

34.1 ARCHITECTURE

The coexistence external interface contains three signals, namely:

1. EXT_ACT0, EXT_ACT1: this is an input to the DA14681 and when asserted, it designates that an external 2.4GHz device is about to issue RF activity.
2. SMART_ACT: this is an output from the DA14681 and when asserted it designates that the DA14681 is transmitting or receiving hence an external device should be aware of the radio activity. The exact timing of the assertion of this signal is depicted in [Figure 125](#).
3. SMART_PRI: this signal is communicating whether the DA14681 has priority over the external devices or not. If asserted, then the external devices could adjust their RF activity accordingly.

34.2 PROGRAMMING

The CoEx block is in the same power domain as the Radio, namely PD_RAD. Hence, the power domain has to be enabled prior to programming the registers. This can be done with `PMU_CTRL_REG[PERIPH_SLEEP]=0`.

Furthermore, as depicted in [Figure 27](#), the CoEx block is clocked by the same clock as the Digital PHY does. Hence the `CLK_RADIO_REG[RFCU_EN]` bit has to be asserted before programming the block's registers.

Any GPIO can be selected to act as EXT_ACT0 or EXT_ACT1, by just programming the `Pxy_MODE_REG[PID]=48/49` (COEX_EXT_ACT0 or COEX_EXT_ACT1), hence two external devices can be supported with the same priority. The behaviour of the SMART_ACT (`Pxy_MODE_REG[PID]=50`) and SMART_PRI (`Pxy_MODE_REG[PID]=51`) output signals is configurable by means of COEX_CTRL_REG and COEX_PRIx_REG registers. The SMART_ACT line will always be asserted if the DA14681 is about to start RF activity if `COEX_CTRL_REG[SMART_ACT_IMPL]=0`. On the contrary, if `COEX_CTRL_REG[SMART_ACT_IMPL]=1` then it is asserted only if DA14681 has higher priority than the external devices as programmed in `COEX_PRIx_REG[COEX_PRI_MAC]`. If not, then both SMART_ACT and SMART_PRI will be de-asserted as long as the EXT_ACT is high disabling the DA14681 RF activity to avoid collisions with the external device.

An overview of the aforementioned scenarios is presented in [Figure 125](#).

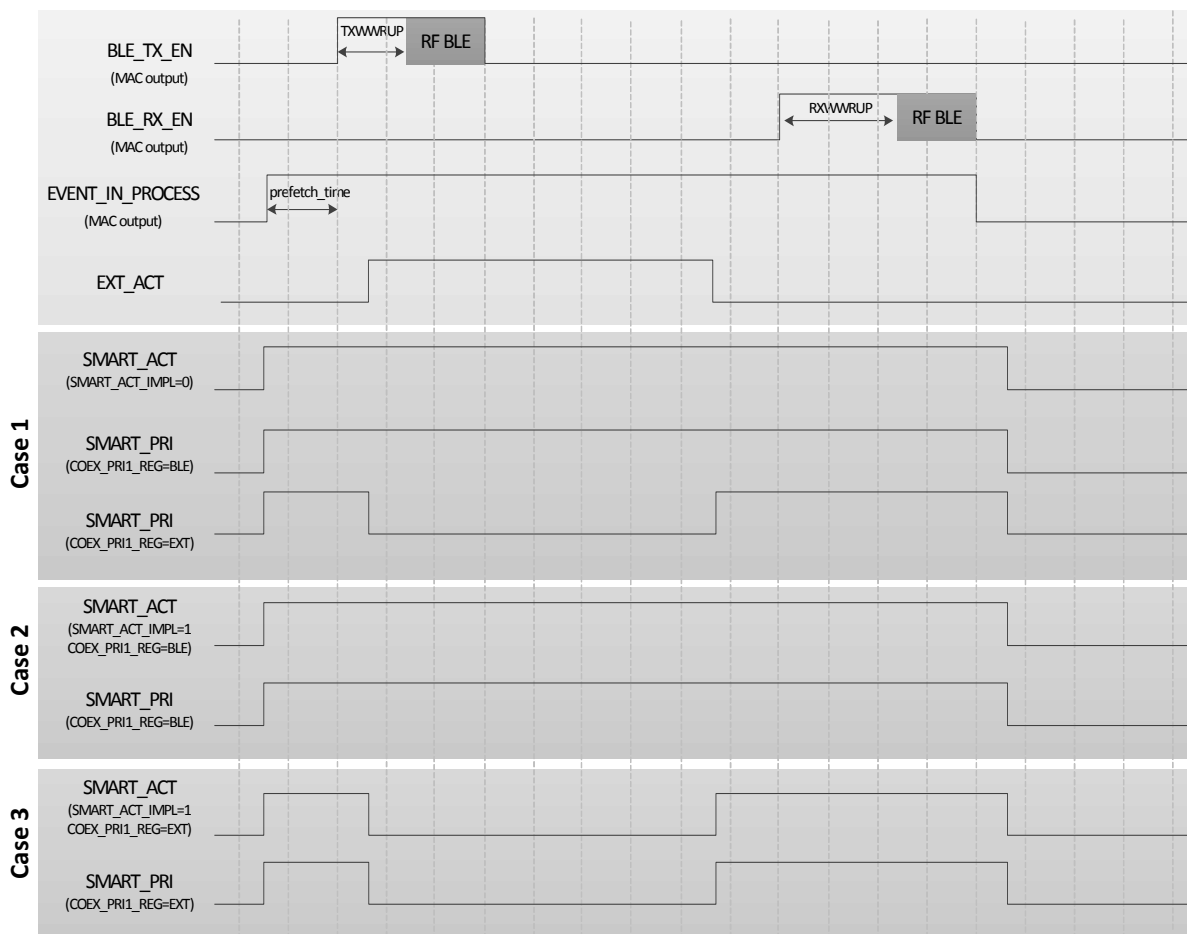

Figure 125: Coexistence signalling cases

Case 1:

Assuming `COEX_CTRL_REG[SMART_ACT_IMPL]=0`, the `SMART_ACT` signal will be asserted with the `event_in_process` BLE MAC signal which is an envelope of an RX and TX event. It will be de-asserted after the de-assertion of the `event_in_process` and as soon as the latest BLE activity is completed designated by an internal signal. `SMART_PRI` notifies whether the BLE has higher priority or not, hence if `COEX_PRI1_REG[COEX_PRI_MAC]=BLE` then it follows the `SMART_ACT` waveform. If `COEX_PRI1_REG[COEX_PRI_MAC]=EXT` then it will be de-asserted whenever the external device notifies its RF activity via `EXT_ACT`.

Case 2:

Assuming `COEX_CTRL_REG[SMART_ACT_IMPL]=1`, the `SMART_ACT` will be asserted only if BLE has priority over the external devices and not always. In this case, the `COEX_PRI1_REG[COEX_PRI_MAC]=BLE` grants priority to the BLE hence the `SMART_ACT` and `SMART_PRI` are asserted at the same time.

Case 3:

In this case the external device has higher priority due to the `COEX_PRI1_REG[COEX_PRI_MAC]=EXT`. Thus, the `SMART_ACT` will not be asserted if an external device signals RF activity via `EXT_ACT`. `SMART_PRI` will also be low as long as `EXT_ACT` is high.

35 Radio

The Radio Transceiver implements the RF part of the DA14681. It provides a 93dB RF link budget for reliable wireless communications.

All RF blocks are supplied by on-chip low-drop out-regulators (LDOs). The bias scheme is programmable per block and optimized for minimum power consumption.

The radio block diagram is given in Figure 126. It comprises the Receiver, Transmitter, Synthesizer, Rx/Tx combiner block, and Biasing LDOs.

Features

- Single ended RFIO interface, 50 Ω matched
- Alignment free operation
- -94.5 dBm receiver sensitivity
- 0 dBm transmit output power
- Ultra low power consumption
- Fast frequency tuning minimises overhead

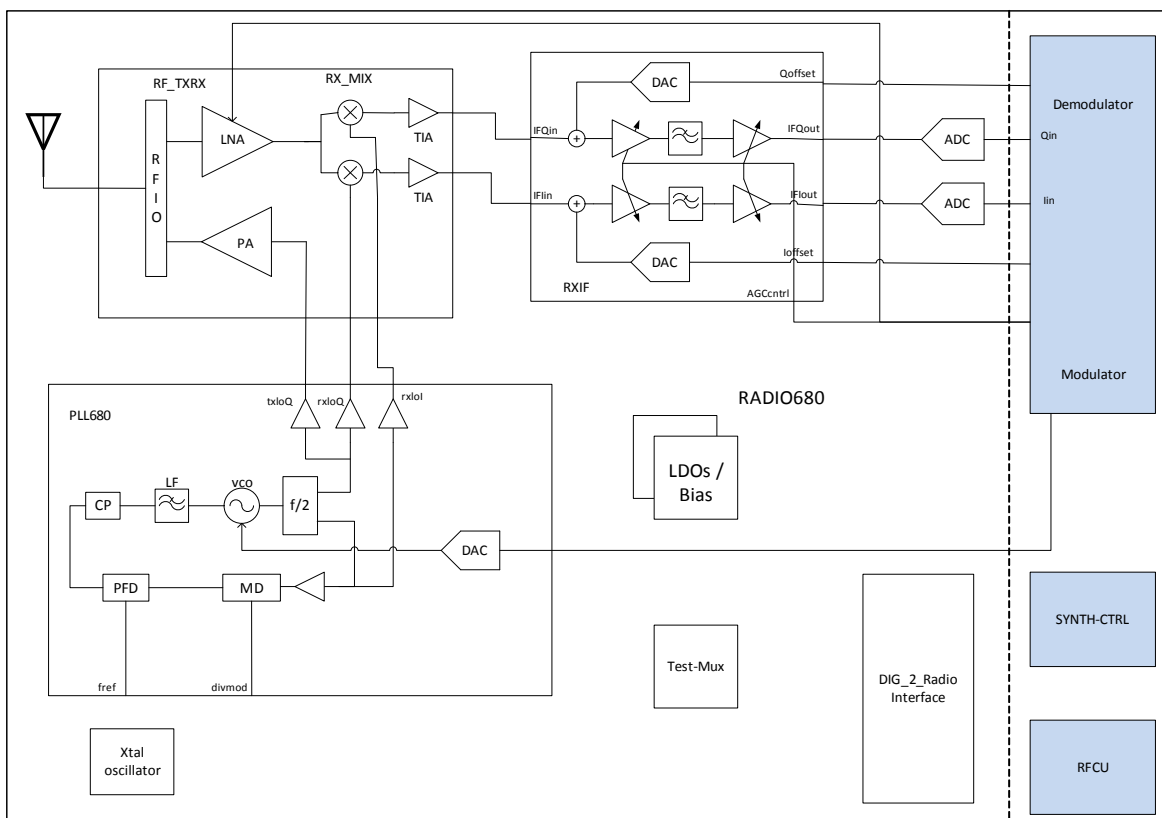

Figure 126: Radio Block Diagram

35.1 ARCHITECTURE

35.1.1 Receiver

The RX frontend consists of a selective matching network, a low noise amplifier (LNA) and an image rejection down conversion mixer. The LNA gain is controlled by the AGC.

The intermediate frequency (IF) part of the receiver comprises a complex filter and 2 variable gain amplifiers. This provides the necessary signal conditioning prior to digitalization. The digital demodulator block (DEM) provides a synchronous bit stream.

35.1.2 Synthesizer

The RF Synthesizer generates the quadrature LO signal for the mixer, but also generates the modulated TX

output signal. The VCO runs at twice the required frequency and a dedicated divide-by-2 circuit generates the 2.4 GHz signals in the required phase relations. Its frequency is controlled by a classic 3rd order type II PLL with a passive loop filter, operated in fractional-*N* mode. The reference frequency is the 16 MHz crystal clock. The multi-modulus divider has a nominal divide ratio of 153 which is varied by a $\Sigma\Delta$ modulator. The modulation of the TX frequency is performed by 2-point modulation. The fractional divide ratio also contains the shaped TX data stream. A second modulation path feeds the TX data stream directly to the VCO. The latter path is automatically calibrated from time to time to align the low and high frequency parts of the 2-point modulation scheme.

35.1.3 Transmitter

The RF power amplifier (RFPA) is an extremely efficient Class-D structure, providing typically 0 dBm to the antenna. It is fed by the VCO's divide-by-2 circuit and delivers its TX power to the antenna pin through the combined RX/TX matching circuit.

35.1.4 RFIO

The RX/TX combiner block is a unique feature of the DA14681. It makes sure that the received power is applied to the LNA with minimum losses towards the RFPA. In TX mode, the LNA poses a minimal load for the RFPA and its input pins are protected from the RFPA. In both modes, the single ended RFIO port is matched to 50 Ω, in order to provide the simplest possible interfacing to the antenna on the printed circuit board.

35.1.5 Biasing

All RF blocks are supplied by on-chip low-drop out-regulators (LDOs). The bias scheme is programmable per block and optimized for minimum power consumption.

35.1.6 Control

The radio control unit (RFCU), controls the block timing and configuration registers. The BLE interfaces directly with the RFCU. The DA14681 can be put in test mode using a standard Bluetooth tester (e.g. Rohde & Schwarz CBT with K57 option) by connecting the antenna terminal for the RF link and the UART as described in section 23.7.

35.2 DYNAMIC CONTROLLED FUNCTIONS

The RF control unit (RFCU) provides the capability of controlling 5 signals which can be used for controlling a Front End Module or an external Power Amplifier. The timing granularity of the DCF signals is 1 us. The DCFs can be output on any GPIO using PID numbers 55 to 59.

The programming of the DCF signals are with respect to the rising and falling edges of the TX_EN or RX_EN signals from the BLE MAC, as depicted in the following figure:

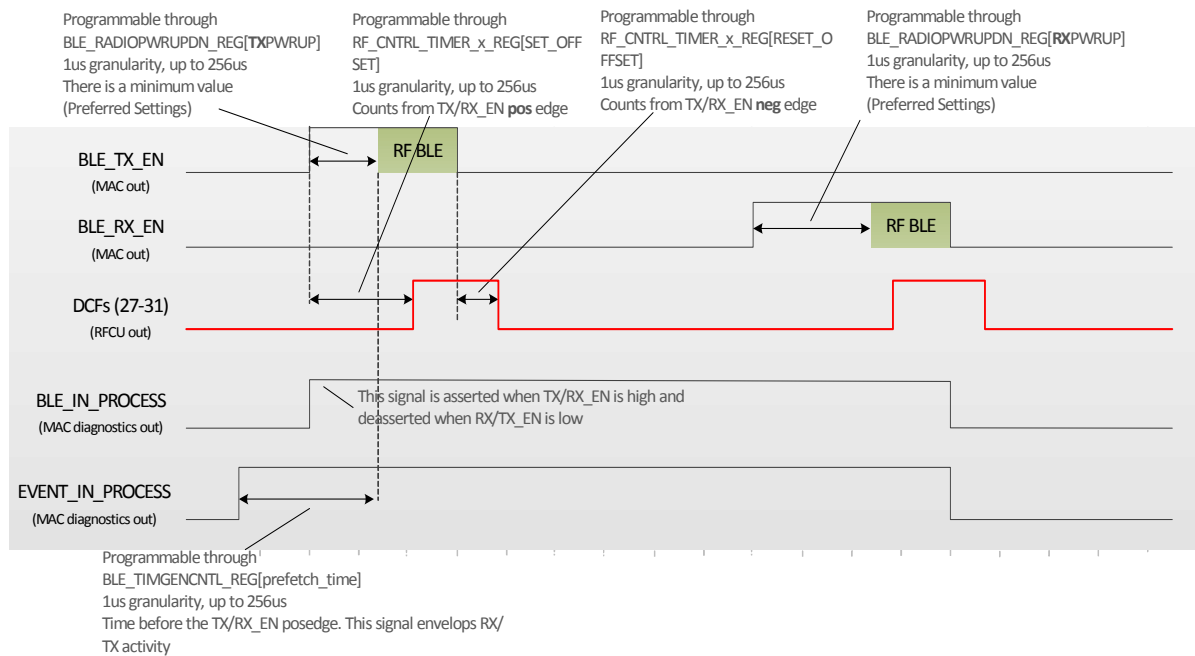

Figure 127: DCF signals programming

35.3 DIAGNOSTIC SIGNALS

There are diagnostic signals that can trigger the rf_diag_irq interrupt line. There are 2 signals from the BLE MAC and 2 signals from the Radio that can actually be programmed to act as this interrupt line sources. They are controlled by the RF_DIAGIRQ01_REG and RF_DIAGIRQ23_REG registers. The overview of the options is provided in the following table:

Table 59: RF_DIAG_IRQ source selection

Word Sel Bit Sel	WSELx= 0 or 1	WSELx= 2 or 3
BSELx=7	ble_diag7	TX_EN
BSELx=6	ble_diag6	RX_EN
BSELx=5	ble_diag5	DCF26

Table 59: RF_DIAG_IRQ source selection

Word Sel Bit Sel	WSELx= 0 or 1	WSELx= 2 or 3
BSELx=4	ble_diag4	DCF25
BSELx=3	ble_diag3	DCF24
BSELx=2	ble_diag2	DCF23
BSELx=1	ble_diag1	DCF22
BSELx=0	ble_diag0	DCF21

There are 4 different selections in these 2 registers namely DIAGIRQ_WSEL_0 to DIAGIRQ_WSEL_3 (designated as WSELx in the table) and DIAGIRQ_BSEL_0 to DIAGIRQ_BSEL_3 (designated as BSELx in the table). They are identical allowing for different signals combinations for the interrupt generation.

The exact definition of the ble_diagx signals are described in [Table 56](#).

The DCF21 to DCF26 signals are programmable timers as explained in the previous section and are used to trigger events in the Radio circuitry.

36 Memory map

This section contains a detailed view of the DA14681 memory map.

Table 60: Memory Map

Address	Description	Power Domain	AMBA
0x0	Remapped Device		
0x7F00000	ROM	SYS_PD	AHB
0x7F40000	OTPC	SYS_PD	AHB
0x7F80000	OTP	SYS_PD	AHB
0x7FC0000	DataRAM	SYS_PD	AHB
0x7FE0000	CacheRAM	SYS_PD	AHB
0x8000000	QSPI FLASH	SYS_PD	AHB
0xC000000	QSPIC	SYS_PD	AHB
0xC0FFFFFF	Reserved		
0x40000000	BLEC	BLE_PD	AHB
0x40020000	AES-HASH	SYS_PD	AHB
0x40030000	ECC_M	SYS_PD	AHB
0x40040000	TRNG_M	SYS_PD	AHB
0x40060000	Reserved		
0x400A0000	CACHE_MTR	SYS_PD	AHB
0x400B0000	CACHE_MDR	SYS_PD	AHB
0x400C3000	CACHEC_MRM	SYS_PD	AHB
0x40098000	Reserved		
0x50000000	CRG	AON_PD	APB16
0x50000100	WKUPC	AON_PD	APB16
0x50000200	TIM1	AON_PD	APB16
0x50000300	Reserved		
0x50001000	UART	PER_PD	APB16
0x50001100	UART2	PER_PD	APB16
0x50001200	SPI	PER_PD	APB16
0x50001300	SPI2	PER_PD	APB16
0x50001400	I2C	PER_PD	APB16
0x50001500	I2C2	PER_PD	APB16
0x50001600	KEYSC	PER_PD	APB16
0x50001700	IR	PER_PD	APB16
0x50001800	USB	PER_PD	APB16
0x50001900	ADC	PER_PD	APB16
0x50001A00	QDEC	PER_PD	APB16
0x50001B00	ANAMISC	PER_PD	APB16
0x50001C00	CRG_PERIPH	PER_PD	APB16
0x50001C4A	Reserved		
0x50002000	RFCU	RAD_PD	APB16
0x50002D00	PLLDIG	RAD_PD	APB16
0x50002E00	DEMODO	RAD_PD	APB16
0x50002F00	COEX	RAD_PD	APB16

Table 60: Memory Map

Address	Description	Power Domain	AMBA
0x50003000	GPIOMUX	SYS_PD	APB16
0x50003100	WDOGTIM	SYS_PD	APB16
0x50003200	VERSION	SYS_PD	APB16
0x50003300	GPREG	SYS_PD	APB16
0x50003400	TIM0/2	SYS_PD	APB16
0x50003500	DMA	SYS_PD	APB16
0x50003600	RFPT	SYS_PD	APB16
0x50004000	APU	PER_PD	APB32
0x50005000	TRNG	SYS_PD	APB32
0x50006000	ECC	RAD_PD	APB16
0x50006100	Reserved		
0xE0000000	ARM Internal Bus	SYS_PD	

Note: AHB implies a full 32-bit aligned address space and a 32 bit data bus. APB16 implies a 16-bit aligned address space and 16-bit data bus. APB32 implies a 32-bit aligned address space and a 32-bit data bus. Byte accesses on either APB16 or APB32 are not allowed.

37 Registers

This section contains a detailed view of the DA14681 registers. It also describes the bitfields in certain registers that will retain their value even if the power domain they reside in, is shut off.

Table 61: Retention Registers

Register	Bit field
BLE_CNTL2_REG	EMACCERRSTAT
	EMACCERRACK
	EMACCERRMSK
	BLE_DIAG_OVRWR_7_5
	BLE_CLK_STAT
	MON_LP_CLK
	RADIO_PWRDN_ALLOW
	BLE_CLK_SEL
	BB_ONLY
	SW_RPL_SPI
	WAKEUPLPSTAT
	BLE_RSSI_SEL
	BLE_EM_BASE_REG
QSPIC_BURSTBRK_REG	QSPIC_BRK_WRD
	QSPIC_BRK_EN
	QSPIC_BRK_SZ
	QSPIC_BRK_TX_MD
QSPIC_BURSTCMD_A_REG	QSPIC_SEC_HF_DS
	QSPIC_INST
	QSPIC_INST_WB
	QSPIC_EXT_BYTE
	QSPIC_INST_TX_MD
	QSPIC_ADR_TX_MD
	QSPIC_EXT_TX_MD
QSPIC_BURSTCMD_B_REG	QSPIC_DMY_TX_MD
	QSPIC_DAT_RX_MD
	QSPIC_EXT_BYTE_EN
	QSPIC_EXT_HF_DS
	QSPIC_DMY_NUM
	QSPIC_INST_MD
	QSPIC_WRAP_MD
	QSPIC_WRAP_LEN
	QSPIC_WRAP_SIZE
	QSPIC_CS_HIGH_MIN
	QSPIC_DMY_FORCE

Table 61: Retention Registers

Register	Bit field
QSPIC_CTRLMODE_REG	QSPIC_AUTO_MD
	QSPIC_CLK_MD
	QSPIC_IO2_OEN
	QSPIC_IO3_OEN
	QSPIC_IO2_DAT
	QSPIC_IO3_DAT
	QSPIC_HRDY_MD
	QSPIC_RXD_NEG
	QSPIC_RPIPE_EN
	QSPIC_PCLK_MD
	QSPIC_FORCENSEQ_EN
	QSPIC_USE_32BA
QSPIC_ERASECMD_A_REG	QSPIC_ERS_INST
	QSPIC_WEN_INST
	QSPIC_SUS_INST
QSPIC_ERASECMD_B_REG	QSPIC_RES_INST
	QSPIC_ERS_TX_MD
	QSPIC_WEN_TX_MD
	QSPIC_SUS_TX_MD
	QSPIC_RES_TX_MD
	QSPIC_EAD_TX_MD
	QSPIC_ERS_CS_HI
QSPIC_ERSRES_HLD	
QSPIC_GP_REG	QSPIC_RESSUS_DLY
	QSPIC_PADS_DRV
QSPIC_STATUSCMD_REG	QSPIC_PADS_SLEW
	QSPIC_RSTAT_INST
	QSPIC_RSTAT_TX_MD
	QSPIC_RSTAT_RX_MD
	QSPIC_BUSY_POS
	QSPIC_BUSY_VAL
	QSPIC_RESSTS_DLY
	QSPIC_STSDLY_SEL
QSPIC_UCODE_START	QSPIC_UCODE_X
CACHE_ASSOCCFG_REG	CACHE_ASSOC
CACHE_CTRL1_REG	CACHE_FLUSH
	CACHE_RES1

Table 61: Retention Registers

1 : Cache registers are only retained if
PMU_CTRL_REG[RETAIN_CACHE=1]

Register	Bit field
CACHE_CTRL2_REG ¹	CACHE_LEN
	CACHE_WEN
	CACHE_CGEN
	ENABLE_ALSO_OTP_CACHED
	ENABLE_ALSO_QSPIFLASH_CACHED
CACHE_CTRL3_REG	CACHE_ASSOCIATIVITY_RESET_VALUE
	CACHE_LINE_SIZE_RESET_VALUE
	CACHE_RAM_SIZE_RESET_VALUE
	CACHE_CONTROLLER_RESET
CACHE_LNSIZECFG_REG	CACHE_LINE
CACHE_MRM_CTRL_REG	MRM_START
	MRM_IRQ_MASK
	MRM_IRQ_TINT_STATUS
	MRM_IRQ_THRES_STATUS
CACHE_MRM_HITS_REG	MRM_HITS
CACHE_MRM_MISSES_REG	MRM_MISSES
CACHE_MRM_THRES_REG	MRM_THRES
CACHE_MRM_TINT_REG	MRM_TINT
SWD_RESET_REG	SWD_HW_RESET_REQ
OTPC_MODE_REG	OTPC_MODE_MODE
OTPC_NWORDS_REG	OTPC_NWORDS
OTPC_TIM1_REG	OTPC_TIM1_CC_T_CADX
	OTPC_TIM1_CC_T_PW
	OTPC_TIM1_CC_T_1US
	OTPC_TIM1_CC_T_500NS
	OTPC_TIM1_CC_T_200NS
	OTPC_TIM1_CC_T_25NS
OTPC_TIM2_REG	OTPC_TIM2_CC_STBY_THR
	OTPC_TIM2_CC_T_BCHK
	OTPC_TIM2_RDENL_PROT
DEBUG_REG	DEBUGS_FREEZE_EN

37.1 OTPC REGISTER FILE

Table 62: Register map OTPC

Address	Port	Description
0x07F40000	OTPC_MODE_REG	Mode register
0x07F40004	OTPC_PCTRL_REG	Bit-programming control register
0x07F40008	OTPC_STAT_REG	Status register
0x07F4000C	OTPC_AHBADR_REG	AHB master start address
0x07F40010	OTPC_CELADR_REG	Macrocell start address
0x07F40014	OTPC_NWORDS_REG	Number of words
0x07F40018	OTPC_FFPRT_REG	Ports access to fifo logic
0x07F4001C	OTPC_FFRD_REG	The data which have taken with the latest read from the OTPC_FFPRT_REG
0x07F40020	OTPC_PWORDL_REG	The 32 lower bits of the 64-bit word that will be programmed, when the MPROG mode is used.
0x07F40024	OTPC_PWORDH_REG	The 32 higher bits of the 64-bit word that will be programmed, when the MPROG mode is used.
0x07F40028	OTPC_TIM1_REG	Various timing parameters of the OTP cell.
0x07F4002C	OTPC_TIM2_REG	Various timing parameters of the OTP cell.

Table 63: OTPC_MODE_REG (0x07F40000)

Bit	Mode	Symbol	Description	Reset
31:30	-	-	Reserved	0x0
29:28	-	-	Reserved	0x0
27:10	-	-	Reserved	0x0
9	R/W	OTPC_MODE_RLD_RR_REQ	Write with 1 in order to be requested the reloading of the repair records. The reloading of the repair records will be performed at the next enabling of the OTP cell. That means that first the controller should be configured to the STBY mode and after should be activated any other mode. The hardware will clear this register, when the reloading will be performed. The reloading has meaning only if the repair records have been updated manually (MPROG mode).	0x0
8	R/W	OTPC_MODE_USE_SP_ROWS	Selects the memory area of the OTP cell that will be used. 0 - Uses the normal memory area of the OTP cell 1 - Uses the spare rows of the OTP cell This selection has meaning only if the mode of the controller is not TDEC and TWR. The controller should be in STBY mode, in order to takes into account this bit. The selection will take effect at the next mode that will be enabled.	0x0
7	-	-	Reserved	0x0

Table 63: OTPC_MODE_REG (0x07F40000)

Bit	Mode	Symbol	Description	Reset
6	R/W	OTPC_MODE_ERR_RESP_DIS	When is performed a read from the OTP memory in the MREAD mode, a double error is likely be detected during the retrieving of the data from the OTP. This error condition is always indicated in the status bit OTPC_STAT_REG[OTPC_STAT_RERROR]. However, the OTP controller has also the ability to indicates this error condition, by generating an ERROR response in the AHB bus. The generation of the ERROR response can be avoided with the help of this configuration bit. 0 - The OTP controller generates an ERROR response in the AHB bus, when a double error is detected during a reading in MREAD mode. The OTPC_STAT_REG[OTPC_STAT_RERROR] is also updated. The receiving of an ERROR response by the CPU causes a Hard Fault exception in the CPU. 1 - Only the OTPC_STAT_REG[OTPC_STAT_RERROR] is updated in a case of such error. The OTP controller will not generate an ERROR response in the AHB bus.	0x0
5	R/W	OTPC_MODE_FIFO_FLUSH	By writing with 1, removes any content from the fifo. This bit returns automatically to value 0.	0x0
4	R/W	OTPC_MODE_USE_DMA	Selects the use of the dma, when the controller is configured in one of the modes: AREAD or APROG. 0 - The dma is not used. The data should be transferred from/to controller through the register OTPC_FFPRT_REG. 1 - The dma is used. The data transfers from/to controller are performed automatically, with the help of the internal DMA of the OTP controller. The AHB base address should be configured in register OTPC_AHBADR_REG, before the selection of one of the two modes: AREAD or APROG.	0x0
3	-	-	Reserved	0x0
2:0	R/W	OTPC_MODE_MODE	Defines the mode of operation of the OTPC controller. The encoding of the modes is as follows: 000 - STBY mode 001 - MREAD mode 010 - MPROG mode 011 - AREAD mode 100 - APROG mode 101 - TBLANK mode 110 - TDEC mode 111 - TWR mode	0x0

Table 64: OTPC_PCTRL_REG (0x07F40004)

Bit	Mode	Symbol	Description	Reset
31:16	-	-	Reserved	0x0
15	R/W	OTPC_PCTRL_PSTART	Write with '1' to trigger the programming of one OTP word, in the case where the MPROG mode is selected. The bit is cleared automatically. The 64-bits that will be programmed into the OTP memory are contained into the two registers OTPC_PWORDx_REG. This bit should be used when a new programming is initiated, but also when the programming must be retried. The OTPC_PCTRL_WADDR defines the OTP position where will be performed the programming.	0x0

Table 64: OTPC_PCTRL_REG (0x07F40004)

Bit	Mode	Symbol	Description	Reset
14	R/W	OTPC_PCTRL_PRETRY	It distinguishes the first attempt of a programming of an OTP position, from a retry of programming. 0 - A new value will be programmed in a blank OTP position. The hardware will try to write all the bits that are equal to '1'. 1 - The programming that is applied is not the first attempt, but is a request for reprogramming. Will be processed only the bits that were failed to be programmed during the previous attempt. The hardware knows the bits that were failed during the previous attempt. The registers OTPC_PWORDx_REG should contain the 64 bits of the value that should be programmed, independent of the value of the OTPC_PCTRL_PRETRY bit. Also, the OTPC_PCTRL_WADDR should contain always the required OTP address. A retry of a programming should be requested only if the previous action was the first attempt of programming or a retry of programming. Should not be requested a retry if the first attempt has not been performed.	0x0
13	-	-	Reserved	0x0
12:0	R/W	OTPC_PCTRL_WADDR	Defines the OTP position where will be programmed the 64-bits that are contained into the registers OTPC_PWORDx_REG. It points to a physical 72 bits OTP word.	0x0

Table 65: OTPC_STAT_REG (0x07F40008)

Bit	Mode	Symbol	Description	Reset
31:30	-	-	Reserved	0x0
29:16	R	OTPC_STAT_NWORDS	It contains the "live" value of the number of (32 bits) words that remain to be processed by the controller.	0x0
15:12	-	-	Reserved	0x0
11:8	R	OTPC_STAT_FWORDS	Indicates the number of words which contained in the fifo of the controller.	0x0
7	R0/WC	OTPC_STAT_RERROR	Indicates that during a normal reading (MREAD or AREAD) was reported a double error by the SECDED logic. That means that the data are corrupted. 0 - The read data are considered as correct. 1 - The SECDED logic detects a double error. This bit can be cleared only with a write with '1'.	0x0
6	R	OTPC_STAT_ARDY	Should be used to monitor the progress of the AREAD and APROG modes. 0 - One of the APROG or AREAD mode is selected. The controller is busy. 1 - The controller is not in an active AREAD or APROG mode.	0x1
5	R	OTPC_STAT_TERROR	Indicates the result of a test sequence. Should be checked after the end of a TBLANK, TDEC and TWR mode (OTPC_STAT_TRDY = 1). 0 - The test sequence ends with no error. 1 - The test sequence has failed.	0x0

Table 65: OTPC_STAT_REG (0x07F40008)

Bit	Mode	Symbol	Description	Reset
4	R	OTPC_STAT_TRDY	Indicates the state of a test mode. Should be used to monitor the progress of the TBLANK, TDEC and TWR modes. 0 - The controller is busy. One of the test modes is in progress. 1 - There is no active test mode.	0x1
3	R	OTPC_STAT_PZER O	Indicates that the programming sequence has been avoided during a programming request, due to that the word that should be programmed is equal to zero. 0 - At least one bit has been programmed into the OTP. 1 - The programming has not been performed. All the bits of the word that should be programmed are equal to zero. When the controller is in MPROG mode, this bit can be checked after the end of the programming process (OTPC_STAT_PRDY = 1). During APROG mode, the value of this field it is normal to changing periodically. After the end of the APROG mode (OTPC_STAT_ARDY = 1), this field indicates that one or more of words that have been processed are equal to zero.	0x0
2	R	OTPC_STAT_PERR_ COR	Indicates that a correctable error has been occurred during the word programming process. 0 - There is no correctable error in the word-programming process. 1 - The process of word - programming reported a correctable error. The correctable error occurs when exactly one bit in an OTP position cannot take the required value. This is not a critical failure in the programming process. The data can still be retrieved correctly by the OTP memory, due to that the error correcting algorithm can repair the corrupted bit. When the controller is in MPROG mode, this bit can be checked after the end of the programming process (OTPC_STAT_PRDY = 1). During APROG mode, the value of this field it is normal to changing periodically. After the end of the APROG mode (OTPC_STAT_ARDY = 1), this field indicates that one or more words had a correctable error.	0x0
1	R	OTPC_STAT_PERR_ UNC	Indicates that an uncorrectable error has been occurred during the word programming process. 0 - There is no uncorrectable error in the word-programming process. 1 - The process of word-programming failed due to an uncorrectable error. An uncorrectable error is considered when two or more of the bits in an OTP position cannot take the required values. This is a critical failure in the programming process, which means that the data cannot corrected by the single error correcting algorithm. When the controller is in MPROG mode, this bit should be checked after the end of the programming process (OTPC_STAT_PRDY = 1). During APROG mode, the value of this field it is normal to changing periodically. After the end of the APROG mode (OTPC_STAT_ARDY = 1), this field indicates if the programming was failed or ended successfully.	0x0

Table 65: OTPC_STAT_REG (0x07F40008)

Bit	Mode	Symbol	Description	Reset
0	R	OTPC_STAT_PRDY	Indicates the state of a bit-programming process. 0 - The controller is busy. A bit-programming is in progress 1 - The logic which performs bit-programming is idle. When the controller is in MPROG mode, this bit should be used to monitor the progress of a programming request. During APROG mode, the value of this field it is normal to changing periodically.	0x1

Table 66: OTPC_AHBADR_REG (0x07F4000C)

Bit	Mode	Symbol	Description	Reset
31:2	R/W	OTPC_AHBADR	It is the AHB address used by the AHB master interface of the controller (the bits [31:2]). The bits [1:0] of the address are considered always as equal to zero.	0x1FF0000
1:0	-	-	Reserved	0x0

Table 67: OTPC_CELADR_REG (0x07F40010)

Bit	Mode	Symbol	Description	Reset
31:14	-	-	Reserved	0x0
13:0	R/W	OTPC_CELADR	It represents an OTP address, where the OTP word width should be considered equal to 32-bits. The physical word width of the OTP memory is 72 bits. The 8-bits of them are used for the implementation of an error correcting code and are not available for the application. The remaining 64 bits of the physical word are available for the application. The OTPC_CELADDR can distinguish the upper 32 bits from the lower 32 bits of the available for the application bits of the OTP word. When OTPC_CELADDR[0] = 1 the address refers to the upper 32 bits of the physical OTP address OTPC_CELADDR[14:1]. The register is used during the modes: AREAD and APROG.	0x0

Table 68: OTPC_NWORDS_REG (0x07F40014)

Bit	Mode	Symbol	Description	Reset
31:14	-	-	Reserved	0x0
13:0	R/W	OTPC_NWORDS	The number of words (minus one) for reading /programming during the AREAD/APROG mode. The width of the word should be considered equal to 32-bits. The value of the register remains unchanged, by the internal logic of the controller. During mirroring, this register reflects the current amount of copied data.	0x0

Table 69: OTPC_FFPRT_REG (0x07F40018)

Bit	Mode	Symbol	Description	Reset
31:0	R/W	OTPC_FFPRT	Provides access to the fifo through an access port. Write to this register with the corresponding data, when the APROG mode is selected and the dma is disabled. Read from this register the corresponding data, when the AREAD mode is selected and the dma is disabled. The software should check the OTPCC_STAT_FWORDS register for the availability of data/space, before accessing the fifo.	0x0

Table 70: OTPC_FFRD_REG (0x07F4001C)

Bit	Mode	Symbol	Description	Reset
31:0	R	OTPC_FFRD	Contains the value which taken from the fifo, after a read of the OTPC_FFPRT_REG register.	0x0

Table 71: OTPC_PWORDL_REG (0x07F40020)

Bit	Mode	Symbol	Description	Reset
31:0	R/W	OTPC_PWORDL	Contains the lower 32 bits that can be programmed with the help of the OTPC_PCTRL_REG, while the controller is in MPROG mode.	0x0

Table 72: OTPC_PWORDH_REG (0x07F40024)

Bit	Mode	Symbol	Description	Reset
31:0	R/W	OTPC_PWORDH	Contains the upper 32 bits that can be programmed with the help of the OTPC_PCTRL_REG, while the controller is in MPROG mode.	0x0

Table 73: OTPC_TIM1_REG (0x07F40028)

Bit	Mode	Symbol	Description	Reset
31	R/W	OTPC_TIM1_CC_T_25NS	The number of hclk_c clock periods (minus one) that give a time interval at least higher than 25ns.	0x0
30:27	R/W	OTPC_TIM1_CC_T_200NS	The number of hclk_c clock periods (minus one) that give a time interval at least higher than 200ns.	0x3
26:22	R/W	OTPC_TIM1_CC_T_500NS	The number of hclk_c clock periods (minus one) that give a time interval at least higher than 500ns	0x8
21:16	R/W	OTPC_TIM1_CC_T_1US	The number of hclk_c clock periods (minus one) that give a time interval at least higher than 1us.	0x10
15:8	R/W	OTPC_TIM1_CC_T_PW	The number of hclk_c clock periods (minus one) that give a time interval that is - at least higher than 4.8us - and lower than 5.2 us It is preferred the programmed value to give a time interval equal to 5us. It defines the duration of the programming pulse for every bit that written in the OTP cell.	0x4F
7:0	R/W	OTPC_TIM1_CC_T_CADX	The number of hclk_c clock periods (minus one) that give a time interval at least higher than 2us. It is used as a wait time each time where the OTP cell is enabled.	0x20

Table 74: OTPC_TIM2_REG (0x07F4002C)

Bit	Mode	Symbol	Description	Reset
31:24	-	-	Reserved	0x0
23	R/W	OTPC_TIM2_RDENL_PROT	This bit has meaning only when the OTPC_TIM1_CC_T_25NS = 1, otherwise has no functionality. 0 - The minimum number of clock cycles for which the signal read_enable of the OTP memory stays inactive is one clock cycle. This is also applicable if OTPC_TIM1_CC_T_25NS = 0. 1 - The minimum number of clock cycles for which the signal read_enable of the OTP memory stays inactive is two clock cycles. The controller adds one extra wait state in the AHB access , if it is required, in order to achieves this constraint. This setting is applicable only if OTPC_TIM1_CC_T_25NS = 1.	0x0
22:16	R/W	OTPC_TIM2_CC_T_BCHK	The number of hclk_c clock periods (minus one) that give a time interval between 100ns and 200ns. This time interval is used for the reading of the contents of the OTP cell during the TBLANK mode.	0x1
15:10	-	-	Reserved	0x0
9:0	R/W	OTPC_TIM2_CC_STBY_THR	This register controls a power saving feature, which is applicable only in MREAD mode. The controller monitors the accesses in the OTP cell. If there is no access for more than OTPC_TIM2_CC_STBY_THR hclk_c clock cycles, the OTP cell goes to the standby while the controller itself remains in the MREAD mode. The OTP cell will be enabled again when will be applied a new read request. The enabling of the OTP cell has a cost of 2us (OTPC_TIM1_CC_T_CADX hclk_c clock cycles). When OTPC_TIM2_CC_STBY_THR = 0 the power saving feature is disabled and the OTP cell remains active while the controller is in MREAD mode.	0x0

37.2 QSPIC REGISTER FILE

Table 75: Register map QSPIC

Address	Port	Description
0x0C000000	QSPIC_CTRLBUS_REG	SPI Bus control register for the Manual mode
0x0C000004	QSPIC_CTRLMODE_REG	Mode Control register
0x0C000008	QSPIC_RECVDATA_REG	Received data for the Manual mode
0x0C00000C	QSPIC_BURSTCMDA_REG	The way of reading in Auto mode (command register A)
0x0C000010	QSPIC_BURSTCMDDB_REG	The way of reading in Auto mode (command register B)
0x0C000014	QSPIC_STATUS_REG	The status register of the QSPI controller
0x0C000018	QSPIC_WRITEDATA_REG	Write data to SPI Bus for the Manual mode
0x0C00001C	QSPIC_READDATA_REG	Read data from SPI Bus for the Manual mode
0x0C000020	QSPIC_DUMMYDATA_REG	Send dummy clocks to SPI Bus for the Manual mode
0x0C000024	QSPIC_ERASECTRL_REG	QSPI Erase control register
0x0C000028	QSPIC_ERASECMDA_REG	The way of erasing in Auto mode (command register A)
0x0C00002C	QSPIC_ERASECMDDB_REG	The way of erasing in Auto mode (command register B)
0x0C000030	QSPIC_BURSTBRK_REG	Read break sequence in Auto mode
0x0C000034	QSPIC_STATUSCMD_REG	The way of reading the status of external device in Auto mode
0x0C000038	QSPIC_CHKERASE_REG	Check erase progress in Auto mode
0x0C00003C	QSPIC_GP_REG	QSPI General Purpose control register

Table 76: QSPIC_CTRLBUS_REG (0x0C000000)

Bit	Mode	Symbol	Description	Reset
31:5	-	-	Reserved	0x0
4	W	QSPIC_DIS_CS	Write 1 to disable the chip select (active low) when the controller is in Manual mode.	0x0
3	W	QSPIC_EN_CS	Write 1 to enable the chip select (active low) when the controller is in Manual mode.	0x0
2	W	QSPIC_SET_QUAD	Write 1 to set the bus mode in Quad mode when the controller is in Manual mode.	0x0
1	W	QSPIC_SET_DUAL	Write 1 to set the bus mode in Dual mode when the controller is in Manual mode.	0x0
0	W	QSPIC_SET_SINGL E	Write 1 to set the bus mode in Single SPI mode when the controller is in Manual mode.	0x0

Table 77: QSPIC_CTRLMODE_REG (0x0C000004)

Bit	Mode	Symbol	Description	Reset
31:14	-	-	Reserved	0x0
13	R/W	QSPIC_USE_32BA	Controls the length of the address that the external memory device uses. 0 - The external memory device uses 24 bits address. 1 - The external memory device uses 32 bits address. The controller uses this bit in order to decide the number of the address bytes that has to transfer to the external device during Auto mode.	0x0

Table 77: QSPIC_CTRLMODE_REG (0x0C000004)

Bit	Mode	Symbol	Description	Reset
12	R/W	QSPIC_FORCENSEQ_EN	Controls the way with which is addressed by the QSPI controller a burst request from the AMBA bus. 0: The controller translates a burst access on the AMBA bus as a burst access on the QSPI bus. That results to the minimum number of command/address phases. 1: The controller will split a burst access on the AMBA bus into a number of single accesses on the QSPI bus. That results to a separate command for each beat of the burst. E.g a 4-beat word incremental AMBA read access will be split into 4 different sequences on the QSPI bus: command/address/extra clock/read data. The QSPI_CS will be low only for the time that is needed for each of these single accesses. This configuration bit is usefull when the clock frequency of the QSPI bus is much higher than the clock of the AMBA bus. In this case the interval for which the CS remains low is minimized, achieving lower power dissipation with respect of the case where the QSPIC_FORCENSEQ_EN=0, at cost of performance.	0x0
11:9	R/W	QSPIC_PCLK_MD	Read pipe clock delay relative to the falling edge of QSPI_SCK. Refer to QSPI Timing for timing parameters and recommended values: 0 to 7	0x0
8	R/W	QSPIC_RPIPE_EN	Controls the use of the data read pipe. 0 = The read pipe is disabled; the sampling clock is defined according to the QSPIC_RXD_NEG setting. 1 = The read pipe is enabled. The delay of the sampling clock is defined according to the QSPI_PCLK_MD setting. (Recommended)	0x0
7	R/W	QSPIC_RXD_NEG	Defines the clock edge that is used for the capturing of the received data, when the read pipe is not active (QSPIC_RPIPE_EN = 0). 0: Sampling of the received data with the positive edge of the QSPI_SCK 1: Sampling of the received data with the negative edge of the QSPI_SCK The internal QSPI_SCK clock that is used by the controller for the capturing of the received data has a skew in respect of the QSPI_SCK that is received by the external memory device. In order to be improved the timing requirements of the read path, the controller supports a read pipe register with programmable clock delay. See also the QSPIC_RPIPE_EN register.	0x0

Table 77: QSPIC_CTRLMODE_REG (0x0C000004)

Bit	Mode	Symbol	Description	Reset
6	R/W	QSPIC_HRDY_MD	This configuration bit is useful when the frequency of the QSPI clock is much lower than the clock of the AMBA bus, in order to not locks the AMBA bus for a long time. 0: Adds wait states via hready signal when an access is performed on the QSPIC_WRITEDATA, QSPIC_READDATA and QSPIC_DUMMYDATA registers. It is not needed to checked the QSPIC_BUSY of the QSPIC_STATUS_REG. 1: The controller don't adds wait states via the hready signal, when is performed access on the QSPIC_WRITEDATA, QSPIC_READDATA and QSPIC_DUMMYDATA registers. The QSPIC_BUSY bit of the QSPIC_STATUS_REG must be checked in order to be detected the completion of the requested access. It is applicable only when the controller is in Manual mode. In the case of the Auto mode, the controller always adds wait states via the hready signal.	0x0
5	R/W	QSPIC_IO3_DAT	The value of QSPI_IO3 pad if QSPI_IO3_OEN is 1	0x0
4	R/W	QSPIC_IO2_DAT	The value of QSPI_IO2 pad if QSPI_IO2_OEN is 1	0x0
3	R/W	QSPIC_IO3_OEN	QSPI_IO3 output enable. Use this only in SPI or Dual SPI mode to control /HOLD signal. When the Auto Mode is selected (QSPIC_AUTO_MD = 1) and the QUAD SPI is used, set this bit to zero. 0: The QSPI_IO3 pad is input. 1: The QSPI_IO3 pad is output.	0x0
2	R/W	QSPIC_IO2_OEN	QSPI_IO2 output enable. Use this only in SPI or Dual SPI mode to control /WP signal. When the Auto Mode is selected (QSPIC_AUTO_MD = 1) and the QUAD SPI is used, set this bit to zero. 0: The QSPI_IO2 pad is input. 1: The QSPI_IO2 pad is output.	0x0
1	R/W	QSPIC_CLK_MD	Mode of the generated QSPI_SCK clock 0: Use Mode 0 for the QSPI_CLK. The QSPI_SCK is low when QSPI_CS is high. 1: Use Mode 3 for the QSPI_CLK. The QSPI_SCK is high when QSPI_CS is high.	0x0
0	R/W	QSPIC_AUTO_MD	Mode of operation 0: The Manual Mode is selected. 1: The Auto Mode is selected. During an erasing the QSPIC_AUTO_MD goes in read only mode (see QSPIC_ERASE_EN)	0x0

Table 78: QSPIC_RECVDATA_REG (0x0C000008)

Bit	Mode	Symbol	Description	Reset
31:0	R	QSPIC_RECVDATA	This register contains the received data when the QSPIC_READDATA_REG register is used in Manual mode, in order to be retrieved data from the external memory device and QSPIC_HRDY_MD=1 && QSPIC_BUSY=0.	0x0

Table 79: QSPIC_BURSTCMDA_REG (0x0C0000C)

Bit	Mode	Symbol	Description	Reset
31:30	R/W	QSPIC_DMY_TX_MD	It describes the mode of the SPI bus during the Dummy bytes phase. 00 - Single SPI 01 - Dual 10 - Quad 11 - Reserved	0x0
29:28	R/W	QSPIC_EXT_TX_MD	It describes the mode of the SPI bus during the Extra Byte phase. 00 - Single SPI 01 - Dual 10 - Quad 11 - Reserved	0x0
27:26	R/W	QSPIC_ADR_TX_MD	It describes the mode of the SPI bus during the address phase. 00 - Single SPI 01 - Dual 10 - Quad 11 - Reserved	0x0
25:24	R/W	QSPIC_INST_TX_MD	It describes the mode of the SPI bus during the instruction phase. 00 - Single SPI 01 - Dual 10 - Quad 11 - Reserved	0x0
23:16	R/W	QSPIC_EXT_BYTE	The value of an extra byte which will be transferred after address (only if QSPIC_EXT_BYTE_EN= 1). Usually this is the Mode Bits in Dual/Quad SPI I/O instructions.	0x0
15:8	R/W	QSPIC_INST_WB	Instruction Value for Wrapping Burst. This value is the selected instruction when QSPIC_WRAP_MD is equal to 1 and the access is a wrapping burst of length and size described by the bit fields QSPIC_WRAP_LEN and QSPIC_WRAP_SIZE respectively.	0x0
7:0	R/W	QSPIC_INST	Instruction Value for Incremental Burst or Single read access. This value is the selected instruction at the cases of incremental burst or single read access. Also this value is used when a wrapping burst is not supported (QSPIC_WRAP_MD)	0x0

Table 80: QSPIC_BURSTCMDDB_REG (0x0C000010)

Bit	Mode	Symbol	Description	Reset
31:16	-	-	Reserved	0x0
15	R/W	QSPIC_DMY_FORC E	By setting this bit, the number of dummy bytes is forced to be equal to 3. In this case the QSPIC_DMY_NUM field is overruled and has no function. 0 - The number of dummy bytes is controlled by the QSPIC_DMY_NUM field 1 - Three dummy bytes are used. The QSPIC_DMY_NUM is overruled.	0x0

Table 80: QSPIC_BURSTCMDDB_REG (0x0C000010)

Bit	Mode	Symbol	Description	Reset
14:12	R/W	QSPIC_CS_HIGH_M IN	Between the transmissions of two different instructions to the flash memory, the SPI bus stays in idle state (QSPI_CS high) for at least this number of QSPI_SCK clock cycles. See the QSPIC_ERS_CS_HI register for some exceptions.	0x0
11:10	R/W	QSPIC_WRAP_SIZE	It describes the selected data size of a wrapping burst (QSPIC_WRAP_MD). 00 - byte access (8-bits) 01 - half word access (16 bits) 10 - word access (32-bits) 11 - Reserved	0x0
9:8	R/W	QSPIC_WRAP_LEN	It describes the selected length of a wrapping burst (QSPIC_WRAP_MD). 00 - 4 beat wrapping burst 01 - 8 beat wrapping burst 10 - 16 beat wrapping burst 11 - Reserved	0x0
7	R/W	QSPIC_WRAP_MD	Wrap mode 0 - The QSPIC_INST is the selected instruction at any access. 1 - The QSPIC_INST_WB is the selected instruction at any wrapping burst access of length and size described by the registers QSPIC_WRAP_LEN and QSPIC_WRAP_SIZE respectively. In all other cases the QSPIC_INST is the selected instruction. Use this feature only when the serial FLASH memory supports a special instruction for wrapping burst access.	0x0
6	R/W	QSPIC_INST_MD	Instruction mode 0 - Transmit instruction at any burst access. 1 - Transmit instruction only in the first access after the selection of Auto Mode.	0x0
5:4	R/W	QSPIC_DMY_NUM	Number of Dummy Bytes 00 - Zero Dummy Bytes (Don't Send Dummy Bytes) 01 - Send 1 Dummy Byte 10 - Send 2 Dummy Bytes 11 - Send 4 Dummy Bytes When QSPIC_DMY_FORCE is enabled, the QSPIC_DMY_NUM is overruled. In this case the number of dummy bytes is defined by the QSPIC_DMY_FORCE and is equal to 3, independent of the value of the QSPIC_DMY_NUM.	0x0
3	R/W	QSPIC_EXT_HF_DS	Extra Half Disable Output 0 - if QSPIC_EXT_BYTE_EN=1, is transmitted the complete QSPIC_EXT_BYTE 1 - if QSPIC_EXT_BYTE_EN=1, the output is disabled (hi-z) during the transmission of bits [3:0] of QSPIC_EXT_BYTE	0x0
2	R/W	QSPIC_EXT_BYTE_ EN	Extra Byte Enable 0 - Don't Send QSPIC_EXT_BYTE 1 - Send QSPIC_EXT_BYTE	0x0

Table 80: QSPIC_BURSTCMDDB_REG (0x0C000010)

Bit	Mode	Symbol	Description	Reset
1:0	R/W	QSPIC_DAT_RX_MD	It describes the mode of the SPI bus during the data phase. 00 - Single SPI 01 - Dual 10 - Quad 11 - Reserved	0x0

Table 81: QSPIC_STATUS_REG (0x0C000014)

Bit	Mode	Symbol	Description	Reset
31:1	-	-	Reserved	0x0
0	R/W	QSPIC_BUSY	The status of the SPI Bus. 0 - The SPI Bus is idle 1 - The SPI Bus is active. Read data, write data or dummy data activity is in progress. Has meaning only in Manual mode and only when QSPIC_HRDY_MD = 1.	0x0

Table 82: QSPIC_WRITEDATA_REG (0x0C000018)

Bit	Mode	Symbol	Description	Reset
31:0	W	QSPIC_WRITEDATA	Writing to this register is generating a data transfer from the controller to the external memory device. The data written in this register is then transferred to the memory using the selected mode of the SPI bus (SPI, Dual SPI, Quad SPI). The data size of the access to this register can be 32-bits / 16-bits/ 8-bits and is equal to the number of the transferred bits. This register has meaning only when the controller is in Manual mode.	0x0

Table 83: QSPIC_READDATA_REG (0x0C00001C)

Bit	Mode	Symbol	Description	Reset
31:0	R	QSPIC_READDATA	A read access at this register generates a data transfer from the external memory device to the QSPIC controller. The data is transferred using the selected mode of the SPI bus (SPI, Dual SPI, Quad SPI). The data size of the access to this register can be 32-bits / 16-bits / 8-bits and is equal to the number of the transferred bits. This register has meaning only when the controller is in Manual mode.	0x0

Table 84: QSPIC_DUMMYDATA_REG (0x0C000020)

Bit	Mode	Symbol	Description	Reset
31:0	W	QSPIC_DUMMYDATA	Writing to this register generates a number of clock pulses to the SPI bus. During the last clock of this activity in the SPI bus, the QSPI_IOx data pads are in hi-z state. The data size of the access to this register can be 32-bits / 16-bits/ 8-bits. The number of generated pulses is equal to: (size of AHB bus access) / (size of SPI bus). The size of SPI bus is equal to 1, 2 or 4 for Single, Dual or Quad SPI mode respectively. This register has meaning only when the controller is in Manual mode.	0x0

Table 85: QSPIC_ERASECTRL_REG (0x0C000024)

Bit	Mode	Symbol	Description	Reset
31:28	-	-	Reserved	0x0
27:25	R	QSPIC_ERS_STATE	It shows the progress of sector/block erasing (read only). 000 = No Erase. 001 = Pending erase request 010 = Erase procedure is running 011 = Suspended Erase procedure 100 = Finishing the Erase procedure 101..111 = Reserved	0x0
24	R/W	QSPIC_ERASE_EN	During Manual mode (QSPIC_AUTO_MD = 0). This bit is in read only mode. During Auto mode (QSPIC_AUTO_MD = 1). To request the erasing of the block/sector (QSPIC_ERS_ADDR, 12'b0) write 1 to this bit. This bit is cleared automatically with the end of the erasing. Until the end of erasing the QSPIC_ERASE_EN remains in read only mode. During the same period of time the controller remains in Auto Mode (QSPIC_AUTO_MD goes in read only mode).	0x0
23:4	R/W	QSPIC_ERS_ADDR	Defines the address of the block/sector that is requested to be erased. If QSPIC_USE_32BA = 0 (24 bits addressing), bits QSPIC_ERASECTRL_REG[23-12] determine the block/sector address bits [23-12]. QSPIC_ERASECTRL_REG[11-4] are ignored by the controller. If QSPIC_USE_32BA = 1 (32 bits addressing) bits QSPIC_ERASECTRL_REG[23-4] determine the block / sectors address bits [31:12]	0x0
3:0	-	-	Reserved	0x0

Table 86: QSPIC_ERASECMDA_REG (0x0C000028)

Bit	Mode	Symbol	Description	Reset
31:24	R/W	QSPIC_RES_INST	The code value of the erase resume instruction	0x0
23:16	R/W	QSPIC_SUS_INST	The code value of the erase suspend instruction.	0x0
15:8	R/W	QSPIC_WEN_INST	The code value of the write enable instruction	0x0
7:0	R/W	QSPIC_ERS_INST	The code value of the erase instruction.	0x0

Table 87: QSPIC_ERASECMDDB_REG (0x0C00002C)

Bit	Mode	Symbol	Description	Reset
31:30	-	-	Reserved	0x0
29:24	R/W	QSPIC_RESSUS_DLY	Defines a timer that counts the minimum allowed delay between an erase suspend command and the previous erase resume command (or the initial erase command). 0 = Dont wait. The controller starts immediately to suspend the erase procedure. 1..63 = The controller waits for at least this number of 222kHz clock cycles before the suspension of erasing. Time starts counting after the end of the previous erase resume command (or the initial erase command)	0x0
23:20	-	-	Reserved	0x0
19:16	R/W	QSPIC_ERSRES_HLD	The controller must stay without flash memory reading requests for this number of AMBA hclk clock cycles, before to perform the command of erase or erase resume 15 - 0	0x0
15	-	-	Reserved	0x0
14:10	R/W	QSPIC_ERS_CS_HI	After the execution of instructions: write enable, erase, erase suspend and erase resume, the QSPI_CS remains high for at least this number of qspi bus clock cycles.	0x0
9:8	R/W	QSPIC_EAD_TX_MD	The mode of the QSPI Bus during the address phase of the erase instruction 00 - Single 01 - Dual 10 - Quad 11 - Reserved	0x0
7:6	R/W	QSPIC_RES_TX_MD	The mode of the QSPI Bus during the transmission of the resume instruction 00 - Single 01 - Dual 10 - Quad 11 - Reserved	0x0
5:4	R/W	QSPIC_SUS_TX_MD	The mode of the QSPI Bus during the transmission of the suspend instruction. 00 - Single 01 - Dual 10 - Quad 11 - Reserved	0x0
3:2	R/W	QSPIC_WEN_TX_MD	The mode of the QSPI Bus during the transmission of the write enable instruction. 00 - Single 01 - Dual 10 - Quad 11 - Reserved	0x0

Table 87: QSPIC_ERASECMD_REG (0x0C00002C)

Bit	Mode	Symbol	Description	Reset
1:0	R/W	QSPIC_ERS_TX_MD	The mode of the QSPI Bus during the instruction phase of the erase instruction 00 - Single 01 - Dual 10 - Quad 11 - Reserved	0x0

Table 88: QSPIC_BURSTBRK_REG (0x0C000030)

Bit	Mode	Symbol	Description	Reset
31:21	-	-	Reserved	0x0
20	R/W	QSPIC_SEC_HF_DS	Disable output during the transmission of the second half (QSPIC_BRK_WRD[3:0]). Setting this bit is only useful if QSPIC_BRK_EN =1 and QSPIC_BRK_SZ= 1. 0 - The controller drives the QSPI bus during the transmission of the QSPIC_BRK_WRD[3:0]. 1 - The controller leaves the QSPI bus in Hi-Z during the transmission of the QSPIC_BRK_WORD[3:0].	0x0
19:18	R/W	QSPIC_BRK_TX_MD	The mode of the QSPI Bus during the transmission of the burst break sequence. 00 - Single 01 - Dual 10 - Quad 11 - Reserved	0x0
17	R/W	QSPIC_BRK_SZ	The size of Burst Break Sequence 0 - One byte (Send QSPIC_BRK_WRD[15:8]) 1 - Two bytes (Send QSPIC_BRK_WRD[15:0])	0x0
16	R/W	QSPIC_BRK_EN	Controls the application of a special command (read burst break sequence) that is used in order to force the device to abandon the continuous read mode. 0 - The special command is not applied 1 - The special command is applied This special command is applied by the controller to the external device under the following conditions: - the controller is in Auto mode - the QSPIC_INST_MD = 1 - the previous command that has been applied in the external device was read - the controller want to apply to the external device a command different than the read.	0x0
15:0	R/W	QSPIC_BRK_WRD	This is the value of a special command (read burst break sequence) that is applied by the controller to the external memory device, in order to force the memory device to abandon the continuous read mode.	0x0

Table 89: QSPIC_STATUSCMD_REG (0x0C000034)

Bit	Mode	Symbol	Description	Reset
31:23	-	-	Reserved	0x0

Table 89: QSPIC_STATUSCMD_REG (0x0C000034)

Bit	Mode	Symbol	Description	Reset
22	R/W	QSPIC_STSDLY_SEL	Defines the timer which is used to count the delay that it has to wait before to read the FLASH Status Register, after an erase or an erase resume command. 0 - The delay is controlled by the QSPIC_RESSTS_DLY which counts on the qspi clock. 1 - The delay is controlled by the QSPIC_RESSUS_DLY which counts on the 222 kHz clock.	0x0
21:16	R/W	QSPIC_RESSTS_DLY	Defines a timer that counts the minimum required delay between the reading of the status register and of the previous erase or erase resume instruction. 0 - Dont wait. The controller starts to reading the Flash memory status register immediately. 1..63 - The controller waits for at least this number of QSPI_CLK cycles and afterwards it starts to reading the Flash memory status register. The timer starts to count after the end of the previous erase or erase resume command. The actual timer that will be used by the controller before the reading of the Flash memory status register is defined by the QSPIC_STSDLY_SEL.	0x0
15	R/W	QSPIC_BUSY_VAL	Defines the value of the Busy bit which means that the flash is busy. 0 - The flash is busy when the Busy bit is equal to 0. 1 - The flash is busy when the Busy bit is equal to 1.	0x0
14:12	R/W	QSPIC_BUSY_POS	It describes who from the bits of status represents the Busy bit (7 - 0).	0x0
11:10	R/W	QSPIC_RSTAT_RX_MD	The mode of the QSPI Bus during the receive status phase of the read status instruction 00 - Single 01 - Dual 10 - Quad 11 - Reserved	0x0
9:8	R/W	QSPIC_RSTAT_TX_MD	The mode of the QSPI Bus during the instruction phase of the read status instruction. 00 - Single 01 - Dual 10 - Quad 11 - Reserved	0x0
7:0	R/W	QSPIC_RSTAT_INST	The code value of the read status instruction. It is transmitted during the instruction phase of the read status instruction.	0x0

Table 90: QSPIC_CHKKERASE_REG (0x0C000038)

Bit	Mode	Symbol	Description	Reset
31:0	W	QSPIC_CHKKERASE	Writing any value to this register during erasing, forces the controller to read the flash memory status register. Depending on the value of the Busy bit, it updates the QSPIC_ERASE_EN.	0x0

Table 91: QSPIC_GP_REG (0x0C00003C)

Bit	Mode	Symbol	Description	Reset
4:3	R/W	QSPIC_PADS_SLEW	QSPI pads slew rate control. Indicative values under certain conditions: 0: Rise=1.7 V/ns, Fall=1.9 V/ns (weak) 1: Rise=2.0 V/ns, Fall=2.3 V/ns 2: Rise=2.3 V/ns, Fall=2.6 V/ns 3: Rise=2.4 V/ns, Fall=2.7 V/ns (strong) Conditions: FLASH pin capacitance 6 pF, Vcc=1.8V, T=25C and Idrive=16mA.	0x0
2:1	R/W	QSPIC_PADS_DRV	QSPI pads drive current 0: 4 mA 1: 8 mA 2: 12 mA 3: 16 mA	0x0
0	-	-	Reserved	0x0

37.3 BLE REGISTER FILE

Table 92: Register map BLE

Address	Port	Description
0x40000000	BLE_RWBLECNTRL_REG	BLE Control register
0x40000004	BLE_VERSION_REG	Version register
0x40000008	BLE_RWBLECONF_REG	Configuration register
0x4000000C	BLE_INTCNTRL_REG	Interrupt controller register
0x40000010	BLE_INTSTAT_REG	Interrupt status register
0x40000014	BLE_INTRAWSTAT_REG	Interrupt raw status register
0x40000018	BLE_INTACK_REG	Interrupt acknowledge register
0x4000001C	BLE_BASETIMECNT_REG	Base time reference counter
0x40000020	BLE_FINETIMECNT_REG	Fine time reference counter
0x40000024	BLE_BDADDRL_REG	BLE device address LSB register
0x40000028	BLE_BDADDRU_REG	BLE device address MSB register
0x4000002C	BLE_CURRENTRXDESCPTR_REG	Rx Descriptor Pointer for the Receive Buffer Chained List
0x40000030	BLE_DEEPSLCNTRL_REG	Deep-Sleep control register
0x40000034	BLE_DEEPSLWKUP_REG	Time (measured in Low Power clock cycles) in Deep Sleep Mode before waking-up the device
0x40000038	BLE_DEEPSLSTAT_REG	Duration of the last deep sleep phase register
0x4000003C	BLE_ENBPRESET_REG	Time in low power oscillator cycles register
0x40000040	BLE_FINECNTCORR_REG	Phase correction value register
0x40000044	BLE_BASETIMECNTCORR_REG	Base Time Counter
0x40000050	BLE_DIAGCNTRL_REG	Diagnostics Register
0x40000054	BLE_DIAGSTAT_REG	Debug use only
0x40000058	BLE_DEBUGADDMAX_REG	Upper limit for the memory zone
0x4000005C	BLE_DEBUGADMIN_REG	Lower limit for the memory zone
0x40000060	BLE_ERRORYPESTAT_REG	Error Type Status registers
0x40000064	BLE_SWPROFILING_REG	Software Profiling register
0x40000070	BLE_RADIOCNTRL0_REG	Radio interface control register
0x40000074	BLE_RADIOCNTRL1_REG	Radio interface control register
0x40000078	BLE_RADIOCNTRL2_REG	Radio interface control register
0x4000007C	BLE_RADIOCNTRL3_REG	Radio interface control register
0x40000080	BLE_RADIOPWRUPDN_REG	RX/TX power up/down phase register
0x40000090	BLE_ADVCHMAP_REG	Advertising Channel Map
0x400000A0	BLE_ADVTIM_REG	Advertising Packet Interval
0x400000A4	BLE_ACTSCANSTAT_REG	Active scan register
0x400000B0	BLE_WLPUBADDPTR_REG	Start address of public devices list
0x400000B4	BLE_WLPRIVADDPTR_REG	Start address of private devices list
0x400000B8	BLE_WLNBDEV_REG	Devices in white list
0x400000C0	BLE_AESCNTRL_REG	Start AES register
0x400000C4	BLE_AESKEY31_0_REG	AES encryption key
0x400000C8	BLE_AESKEY63_32_REG	AES encryption key
0x400000CC	BLE_AESKEY95_64_REG	AES encryption key
0x400000D0	BLE_AESKEY127_96_REG	AES encryption key
0x400000D4	BLE_AESPTR_REG	Pointer to the block to encrypt/decrypt
0x400000D8	BLE_TXMICVAL_REG	AES / CCM plain MIC value

Table 92: Register map BLE

Address	Port	Description
0x400000DC	BLE_RXMICVAL_REG	AES / CCM plain MIC value
0x400000E0	BLE_RFTESTCNTL_REG	RF Testing Register
0x400000E4	BLE_RFTESTTXSTAT_REG	RF Testing Register
0x400000E8	BLE_RFTESTRXSTAT_REG	RF Testing Register
0x400000F0	BLE_TIMGENCNTL_REG	Timing Generator Register
0x400000F4	BLE_GROSSTIMTGT_REG	Gross Timer Target value
0x400000F8	BLE_FINETIMTGT_REG	Fine Timer Target value
0x400000FC	BLE_SAMPLECLK_REG	Samples the Base Time Counter
0x40000100	BLE_COEXIFCNTL0_REG	Coexistence interface Control 0 Register
0x40000104	BLE_COEXIFCNTL1_REG	Coexistence interface Control 1 Register
0x40000108	BLE_BLEMPRIO0_REG	Coexistence interface Priority 0 Register
0x4000010C	BLE_BLEMPRIO1_REG	Coexistence interface Priority 1 Register
0x40000110	BLE_BLEPRIOSCHARB_REG	Priority Scheduling Arbiter Control Register
0x40000200	BLE_CNTL2_REG	BLE Control Register 2
0x40000208	BLE_EM_BASE_REG	Exchange Memory Base Register
0x4000020C	BLE_DIAGCNTL2_REG	Debug use only
0x40000210	BLE_DIAGCNTL3_REG	Debug use only

Table 93: BLE_RWBLECNTL_REG (0x40000000)

Bit	Mode	Symbol	Description	Reset
31	R0/W	MASTER_SOFT_RST	Reset the complete BLE Core except registers and timing generator, when written with a 1. Resets at 0 when action is performed. No action happens if it is written with 0.	0x0
30	R0/W	MASTER_TGSOFT_RST	Reset the timing generator, when written with a 1. Resets at 0 when action is performed. No action happens if it is written with 0.	0x0
29	R/W	REG_SOFT_RST	Reset the complete register block, when written with a 1. Resets at 0 when action is performed. No action happens if it is written with 0. Note that INT_STAT will not be cleared, so the user should also write to BLE_INTACK_REG after the SW Reset	0x0
28	R0/W	SWINT_REQ	Forces the generation of ble_sw_irq when written with a 1, and proper masking is set. Resets at 0 when action is performed. No action happens if it is written with 0.	0x0
26	R0/W	RFTEST_ABORT	Abort the current RF Testing defined as per CS-FORMAT when written with a 1. Resets at 0 when action is performed. No action happens if it is written with 0. Note that when RFTEST_ABORT is requested: 1) In case of infinite Tx, the Packet Controller FSM stops at the end of the current byte in process, and processes accordingly the packet CRC. 2) In case of Infinite Rx, the Packet Controller FSM either stops as the end of the current Packet reception (if Access address has been detected), or simply stop the processing switching off the RF.	0x0
25	R0/W	ADVERT_ABORT	Abort the current Advertising event when written with a 1. Resets at 0 when action is performed. No action happens if it is written with 0.	0x0

Table 93: BLE_RWBLECNTL_REG (0x40000000)

Bit	Mode	Symbol	Description	Reset
24	R0/W	SCAN_ABORT	Abort the current scan window when written with a 1. Resets at 0 when action is performed. No action happens if it is written with 0.	0x0
22	R/W	MD_DSB	0: Normal operation of MD bits management 1: Allow a single Tx/Rx exchange whatever the MD bits are. - value forced by SW from Tx Descriptor - value just saved in Rx Descriptor during reception	0x0
21	R/W	SN_DSB	0: Normal operation of Sequence number 1: Sequence Number Management disabled: - value forced by SW from Tx Descriptor - value ignored in Rx, where no SN error reported.	0x0
20	R/W	NESN_DSB	0: Normal operation of Acknowledge 1: Acknowledge scheme disabled: - value forced by SW from Tx Descriptor - value ignored in Rx, where no NESN error reported.	0x0
19	R/W	CRYPT_DSB	0: Normal operation. Encryption / Decryption enabled. 1: Encryption / Decryption disabled. Note that if CS-CRYPT_EN is set, then MIC is generated, and only data encryption is disabled, meaning data sent are plain data.	0x0
18	R/W	WHIT_DSB	0: Normal operation. Whitening enabled. 1: Whitening disabled.	0x0
17	R/W	CRC_DSB	0: Normal operation. CRC removed from data stream. 1: CRC stripping disabled on Rx packets, CRC replaced by 0x000 in Tx.	0x0
16	R/W	HOP_REMAP_DSB	0: Normal operation. Frequency Hopping Remapping algorithm enabled. 1: Frequency Hopping Remapping algorithm disabled	0x0
13:12	R/W	CORR_MODE	Defines correlation mode, meaningful only if RW_BLE_CORR_PREAMBLE_ENABLE is set 00: Correlates onto Access Address 01: Correlates onto half preamble and Access Address 10: Correlates onto full preamble and Access Address 11: n/a	0x0
9	R/W	ADVERTFILT_EN	Advertising Channels Error Filtering Enable control 0: RW-BLE Core reports all errors to RW-BLE Software 1: RW-BLE Core reports only correctly received packet, without error to RW-BLE Software	0x0
8	R/W	RWBLE_EN	0: Disable RW-BLE Core Exchange Table pre-fetch mechanism. 1: Enable RW-BLE Core Exchange table pre-fetch mechanism.	0x0
7:4	R/W	RXWINSZDEF	Default Rx Window size in us. Used when device: • is master connected • performs its second receipt. 0 is not a valid value. Recommended value is 10 (in decimal).	0x0
2:0	R/W	SYNCERR	Indicates the maximum number of errors allowed to recognize the synchronization word.	0x0

Table 94: BLE_VERSION_REG (0x40000004)

Bit	Mode	Symbol	Description	Reset
31:24	R	TYP	BLE Core Type	0x1

Table 94: BLE_VERSION_REG (0x40000004)

Bit	Mode	Symbol	Description	Reset
23:16	R	REL	BLE Core version Major release number.	0x0
15:8	R	UPG	BLE Core upgrade Upgrade number.	0x0
7:0	R	BUILD	BLE Core Build Build number.	0x0

Table 95: BLE_RWBLECONF_REG (0x40000008)

Bit	Mode	Symbol	Description	Reset
29:24	R	ADD_WIDTH	Value of the RW_BLE_ADDRESS_WIDTH parameter converted into binary.	0x10
22:16	R	RFIF	Radio Interface ID	0x2
13:8	R	CLK_SEL	Operating Frequency (in MHz)	0x0
6	R/W	DECIPHER	0: AES deciphering not present	0x0
5	R	DMMODE	0: RW-BLE Core is used as a standalone BLE device	0x0
4	R	INTMODE	1: Interrupts are trigger level generated, i.e. stays active at 1 till acknowledgement	0x1
3	R	COEX	1: WLAN Coexistence mechanism present	0x1
2	R	USEDDBG	1: Diagnostic port instantiated	0x1
1	R	USECRYPT	1: AES-CCM Encryption block present	0x1
0	R	BUSWIDTH	Processor bus width: 1: 32 bits	0x1

Table 96: BLE_INTCNTL_REG (0x4000000C)

Bit	Mode	Symbol	Description	Reset
15	R/W	CSCNTDEVMSK	CSCNT interrupt mask during event. This bit allows to enable CSCNT interrupt generation during events (i.e. advertising, scanning, initiating, and connection) 0: CSCNT Interrupt not generated during events. 1: CSCNT Interrupt generated during events.	0x1
9	R/W	SWINTMSK	SW triggered interrupt Mask 0: Interrupt not generated 1: Interrupt generated	0x0
8	R/W	EVENTAPFAINTMSK	End of event / anticipated pre-fetch abort interrupt Mask 0: Interrupt not generated 1: Interrupt generated	0x1
7	R/W	FINETGTIMINTMSK	Fine Target Timer Mask 0: Interrupt not generated 1: Interrupt generated	0x0
6	R/W	GROSSTGTIMINT-MSK	Gross Target Timer Mask 0: Interrupt not generated 1: Interrupt generated	0x0
5	R/W	ERRORINTMSK	Error Interrupt Mask 0: Interrupt not generated 1: Interrupt generated	0x0
4	R/W	CRYPTINTMSK	Encryption engine Interrupt Mask 0: Interrupt not generated 1: Interrupt generated	0x1
3	R/W	EVENTINTMSK	End of event Interrupt Mask 0: Interrupt not generated 1: Interrupt generated	0x1

Table 96: BLE_INTCNTL_REG (0x4000000C)

Bit	Mode	Symbol	Description	Reset
2	R/W	SLPINTMSK	Sleep Mode Interrupt Mask 0: Interrupt not generated 1: Interrupt generated	0x1
1	R/W	RXINTMSK	Rx Interrupt Mask 0: Interrupt not generated 1: Interrupt generated	0x1
0	R/W	CSCNTINTMSK	625us Base Time Interrupt Mask 0: Interrupt not generated 1: Interrupt generated	0x1

Table 97: BLE_INTSTAT_REG (0x40000010)

Bit	Mode	Symbol	Description	Reset
9	R	SWINTSTAT	SW triggered interrupt status 0: No SW triggered interrupt. 1: A SW triggered interrupt is pending	0x0
8	R	EVENTAPFAINT-STAT	End of event / Anticipated Pre-Fetch Abort interrupt status 0: No End of Event interrupt. 1: An End of Event interrupt is pending.	0x0
7	R	FINETGTIMINTSTAT	Masked Fine Target Timer Error interrupt status 0: No Fine Target Timer interrupt. 1: A Fine Target Timer interrupt is pending.	0x0
6	R	GROSSTGTIMINT-STAT	Masked Gross Target Timer interrupt status 0: No Gross Target Timer interrupt. 1: A Gross Target Timer interrupt is pending.	0x0
5	R	ERRORINTSTAT	Masked Error interrupt status 0: No Error interrupt. 1: An Error interrupt is pending.	0x0
4	R	CRYPTINTSTAT	Masked Encryption engine interrupt status 0: No Encryption / Decryption interrupt. 1: An Encryption / Decryption interrupt is pending.	0x0
3	R	EVENTINTSTAT	Masked End of Event interrupt status 0: No End of Advertising / Scanning / Connection interrupt. 1: An End of Advertising / Scanning / Connection interrupt is pending.	0x0
2	R	SLPINTSTAT	Masked Sleep interrupt status 0: No End of Sleep Mode interrupt. 1: An End of Sleep Mode interrupt is pending.	0x0
1	R	RXINTSTAT	Masked Packet Reception interrupt status 0: No Rx interrupt. 1: An Rx interrupt is pending.	0x0
0	R	CSCNTINTSTAT	Masked 625us base time reference interrupt status 0: No 625us Base Time interrupt. 1: A 625us Base Time interrupt is pending.	0x0

Table 98: BLE_INTRAWSTAT_REG (0x40000014)

Bit	Mode	Symbol	Description	Reset
9	R	SWINTRAWSTAT	SW triggered interrupt raw status 0: No SW triggered interrupt. 1: A SW triggered interrupt is pending.	0x0

Table 98: BLE_INTRAWSTAT_REG (0x40000014)

Bit	Mode	Symbol	Description	Reset
8	R	EVENTAPFAINT-RAWSTAT	End of event / Anticipated Pre-Fetch Abort interrupt raw status 0: No End of Event interrupt. 1: An End of Event interrupt is pending.	0x0
7	R	FINETGTIMINTRA-STAT	Fine Target Timer Error interrupt raw status 0: No Fine Target Timer interrupt. 1: A Fine Target Timer interrupt is pending.	0x0
6	R	GROSSTGTIMIN-TRA-STAT	Gross Target Timer interrupt raw status 0: No Gross Target Timer interrupt. 1: A Gross Target Timer interrupt is pending.	0x0
5	R	ERRORINTRA-STAT	Error interrupt raw status 0: No Error interrupt. 1: An Error interrupt is pending.	0x0
4	R	CRYPTINTRA-STAT	Encryption engine interrupt raw status 0: No Encryption / Decryption interrupt. 1: An Encryption / Decryption interrupt is pending.	0x0
3	R	EVENTINTRA-STAT	End of Event interrupt raw status 0: No End of Advertising / Scanning / Connection interrupt. 1: An End of Advertising / Scanning / Connection interrupt is pending.	0x0
2	R	SLPINTRA-STAT	Sleep interrupt raw status 0: No End of Sleep Mode interrupt. 1: An End of Sleep Mode interrupt is pending.	0x0
1	R	RXINTRA-STAT	Packet Reception interrupt raw status 0: No Rx interrupt. 1: An Rx interrupt is pending.	0x0
0	R	CSCNTINTRA-STAT	625us base time reference interrupt raw status 0: No 625us Base Time interrupt. 1: A 625us Base Time interrupt is pending.	0x0

Table 99: BLE_INTACK_REG (0x40000018)

Bit	Mode	Symbol	Description	Reset
9	R0/W	SWINTACK	SW triggered interrupt acknowledgement bit Software writing 1 acknowledges the SW triggered interrupt. This bit resets SWINTSTAT and SWINTRA-STAT flags. Resets at 0 when action is performed	0x0
8	R0/W	EVENTAPFAINTACK	End of event / Anticipated Pre-Fetch Abort interrupt acknowledgement bit Software writing 1 acknowledges the End of event / Anticipated Pre-Fetch Abort interrupt. This bit resets EVENTAPFAINTSTAT and EVENTAPFAINTRA-STAT flags. Resets at 0 when action is performed	0x0
7	R0/W	FINETGTIMINTACK	Fine Target Timer interrupt acknowledgement bit Software writing 1 acknowledges the Fine Timer interrupt. This bit resets FINETGTIMINTSTAT and FINETGTIMINTRA-STAT flags. Resets at 0 when action is performed	0x0
6	R0/W	GROSSTGTI-MINTACK	Gross Target Timer interrupt acknowledgement bit Software writing 1 acknowledges the Gross Timer interrupt. This bit resets GROSSTGTIMINTSTAT and GROSSTGTIMINTRA-STAT flags. Resets at 0 when action is performed	0x0

Table 99: BLE_INTACK_REG (0x40000018)

Bit	Mode	Symbol	Description	Reset
5	R0/W	ERRORINTACK	Error interrupt acknowledgement bit Software writing 1 acknowledges the Error interrupt. This bit resets ERRORINTSTAT and ERRORINTRAWSTAT flags. Resets at 0 when action is performed	0x0
4	R0/W	CRYPTINTACK	Encryption engine interrupt acknowledgement bit Software writing 1 acknowledges the Encryption engine interrupt. This bit resets CRYPTINTSTAT and CRYPTINTRAWSTAT flags. Resets at 0 when action is performed	0x0
3	R0/W	EVENTINTACK	End of Event interrupt acknowledgment bit Software writing 1 acknowledges the End of Advertising / Scanning / Connection interrupt. This bit resets SLPINTSTAT and SLPINTRAWSTAT flags. Resets at 0 when action is performed	0x0
2	R0/W	SLPINTACK	End of Deep Sleep interrupt acknowledgment bit Software writing 1 acknowledges the End of Sleep Mode interrupt. This bit resets SLPINTSTAT and SLPINTRAWSTAT flags. Resets at 0 when action is performed	0x0
1	R0/W	RXINTACK	Packet Reception interrupt acknowledgment bit Software writing 1 acknowledges the Rx interrupt. This bit resets RXINTSTAT and RXINTRAWSTAT flags. Resets at 0 when action is performed	0x0
0	R0/W	CSCNTINTACK	625us base time reference interrupt acknowledgment bit Software writing 1 acknowledges the CLKN interrupt. This bit resets CLKINTSTAT and CLKINTRAWSTAT flags. Resets at 0 when action is performed	0x0

Table 100: BLE_BASETIMECNT_REG (0x4000001C)

Bit	Mode	Symbol	Description	Reset
26:0	R	BASETIMECNT	Value of the 625us base time reference counter. Updated each time SAMPCLK is written. Used by the SW in order to synchronize with the HW	0x0

Table 101: BLE_FINETIMECNT_REG (0x40000020)

Bit	Mode	Symbol	Description	Reset
9:0	R	FINECNT	Value of the current s fine time reference counter. Updated each time SAMPCLK is written. Used by the SW in order to synchronize with the HW, and obtain a more precise sleep duration	0x0

Table 102: BLE_BDADDR_L_REG (0x40000024)

Bit	Mode	Symbol	Description	Reset
31:0	R/W	BDADDR_L	Bluetooth Low Energy Device Address. LSB part.	0x0

Table 103: BLE_BDADDR_U_REG (0x40000028)

Bit	Mode	Symbol	Description	Reset
16	R/W	PRIV_NPUB	Bluetooth Low Energy Device Address privacy indicator 0: Public Bluetooth Device Address 1: Private Bluetooth Device Address	0x0

Table 103: BLE_BDADDRU_REG (0x40000028)

Bit	Mode	Symbol	Description	Reset
15:0	R/W	BDADDRU	Bluetooth Low Energy Device Address. MSB part.	0x0

Table 104: BLE_CURRENTRXDESCPTR_REG (0x4000002C)

Bit	Mode	Symbol	Description	Reset
31:16	R/W	ETPTR	Exchange Table Pointer that determines the starting point of the Exchange Table	0x0
14:0	R/W	CURRENTRX-DESCPTR	Rx Descriptor Pointer that determines the starting point of the Receive Buffer Chained List	0x0

Table 105: BLE_DEEPSLCNTL_REG (0x40000030)

Bit	Mode	Symbol	Description	Reset
31	R/W	EXTWKUPDSB	External Wake-Up disable 0: RW-BLE Core can be woken by external wake-up 1: RW-BLE Core cannot be woken up by external wake-up	0x0
15	R	DEEP_SLEEP_STAT	Indicator of current Deep Sleep clock mux status: 0: RW-BLE Core is not yet in Deep Sleep Mode 1: RW-BLE Core is in Deep Sleep Mode (only low_power_clk is running)	0x0
4	R0/W	SOFT_WAKEUP_REQ	Wake Up Request from RW-BLE Software. Applies when system is in Deep Sleep Mode. It wakes up the RW-BLE Core when written with a 1. Resets at 0 when action is performed. No action happens if it is written with 0.	0x0
3	R0/W	DEEP_SLEEP_CORR_EN	625us base time reference integer and fractional part correction. Applies when system has been woken-up from Deep Sleep Mode. It enables Fine Counter and Base Time counter when written with a 1. Resets at 0 when action is performed. No action happens if it is written with 0.	0x0
2	R0/W	DEEP_SLEEP_ON	0: RW-BLE Core in normal active mode 1: Request RW-BLE Core to switch in deep sleep mode. This bit is reset on DEEP_SLEEP_STAT falling edge.	0x0
1:0	R/W	DEEP_SLEEP_IRQ_EN	Always set to "3" when DEEP_SLEEP_ON is set to "1". It controls the generation of BLE_WAKEUP_LP_IRQ.	0x0

Table 106: BLE_DEEPSLWKUP_REG (0x40000034)

Bit	Mode	Symbol	Description	Reset
31:0	R/W	DEEPSLTIME	Determines the time in low_power_clk clock cycles to spend in Deep Sleep Mode before waking-up the device. This ensures a maximum of 37 hours and 16mn sleep mode capabilities at 32kHz. This ensures a maximum of 36 hours and 16mn sleep mode capabilities at 32.768kHz	0x0

Table 107: BLE_DEEPSLSTAT_REG (0x40000038)

Bit	Mode	Symbol	Description	Reset
31:0	R	DEEPSLDUR	Actual duration of the last deep sleep phase measured in low_power_clk clock cycle. DEEPSLDUR is set to zero at the beginning of the deep sleep phase, and is incremented at each low_power_clk clock cycle until the end of the deep sleep phase.	0x0

Table 108: BLE_ENBPRESET_REG (0x4000003C)

Bit	Mode	Symbol	Description	Reset
31:21	R/W	TWEXT	Minimum and recommended value is "TWIRQ_RESET + 1". In the case of wake-up due to an external wake-up request, TWEXT specifies the time delay in low power oscillator cycles to deassert BLE_WAKEUP_LP_IRQ. Refer also to GP_CONTROL_REG[BLE_WAKEUP_REQ]. Range is [0...64 ms] for 32kHz; [0...62.5 ms] for 32.768kHz	0x0
20:10	R/W	TWIRQ_SET	Minimum value is "TWIRQ_RESET + 1". Time in low power oscillator cycles to set BLE_WAKEUP_LP_IRQ before the BLE sleep timer expiration. Refer also to BLE_DEEPSLWKUP_REG[DEEPSLTIME]. Range is [0...64 ms] for 32kHz; [0...62.5 ms] for 32.768kHz	0x0
9:0	R/W	TWIRQ_RESET	Recommended value is 1. Time in low power oscillator cycles to reset BLE_WAKEUP_LP_IRQ before the BLE sleep timer expiration. Refer also to BLE_DEEPSLWKUP_REG[DEEPSLTIME]. Range is [0...32 ms] for 32kHz; [0...31.25 ms] for 32.768kHz.	0x0

Table 109: BLE_FINECNTCORR_REG (0x40000040)

Bit	Mode	Symbol	Description	Reset
9:0	R/W	FINECNTCORR	Phase correction value for the 625us reference counter (i.e. Fine Counter) in us.	0x0

Table 110: BLE_BASETIMECNTCORR_REG (0x40000044)

Bit	Mode	Symbol	Description	Reset
26:0	R/W	BASETIMECNT-CORR	Base Time Counter correction value.	0x0

Table 111: BLE_DIAGCNTL_REG (0x40000050)

Bit	Mode	Symbol	Description	Reset
-	-	-	Undefined	-

Table 112: BLE_DIAGSTAT_REG (0x40000054)

Bit	Mode	Symbol	Description	Reset
-	-	-	Undefined	-

Table 113: BLE_DEBUGADDMAX_REG (0x40000058)

Bit	Mode	Symbol	Description	Reset
31:16	R/W	REG_ADDMAX	Upper limit for the Register zone indicated by the reg_inzone flag	0x0
15:0	R/W	EM_ADDMAX	Upper limit for the Exchange Memory zone indicated by the em_inzone flag	0x0

Table 114: BLE_DEBUGADMIN_REG (0x4000005C)

Bit	Mode	Symbol	Description	Reset
31:16	R/W	REG_ADDMIN	Lower limit for the Register zone indicated by the reg_inzone flag	0x0
15:0	R/W	EM_ADDMIN	Lower limit for the Exchange Memory zone indicated by the em_inzone flag	0x0

Table 115: BLE_ERRORTYPESTAT_REG (0x40000060)

Bit	Mode	Symbol	Description	Reset
17	R/W	CONCEVTIRQ_ERR OR	Indicates whether two consecutive and concurrent ble_event_irq have been generated, and not acknowledged in time by the RW-BLE Software. 0: No error 1: Error occurred	0x0
16	R	RXDATA_PTR_ERR OR	Indicates whether Rx data buffer pointer value programmed is null: this is a major programming failure. 0: No error 1: Error occurred	0x0
15	R	TXDATA_PTR_ERR OR	Indicates whether Tx data buffer pointer value programmed is null during Advertising / Scanning / Initiating events, or during Master / Slave connections with non-null packet length: this is a major programming failure. 0: No error 1: Error occurred	0x0
14	R	RXDESC_EMPTY_ERROR	Indicates whether Rx Descriptor pointer value programmed in register is null: this is a major programming failure. 0: No error 1: Error occurred	0x0
13	R	TXDESC_EMPTY_ERROR	Indicates whether Tx Descriptor pointer value programmed in Control Structure is null during Advertising / Scanning / Initiating events: this is a major programming failure. 0: No error 1: Error occurred	0x0
12	R	CSFORMAT_ERROR	Indicates whether CS-FORMAT has been programmed with an invalid value: this is a major software programming failure. 0: No error 1: Error occurred	0x0
11	R	LLCHMAP_ERROR	Indicates Link Layer Channel Map error, happens when actual number of CS-LLCHMAP bit set to one is different from CS-NBCHGOOD at the beginning of Frequency Hopping process 0: No error 1: Error occurred	0x0
10	R	ADV_UNDERRUN	Indicates Advertising Interval Under run, occurs if time between two consecutive Advertising packet (in Advertising mode) is lower than the expected value. 0: No error 1: Error occurred	0x0
9	R	IFS_UNDERRUN	Indicates Inter Frame Space Under run, occurs if IFS time is not enough to update and read Control Structure/Descriptors, and/or White List parsing is not finished and/or Decryption time is too long to be finished on time 0: No error 1: Error occurred	0x0

Table 115: BLE_ERRORTYPESTAT_REG (0x40000060)

Bit	Mode	Symbol	Description	Reset
8	R	WHITELIST_ERROR	Indicates White List Timeout error, occurs if White List parsing is not finished on time 0: No error 1: Error occurred	0x0
7	R	EVT_CNTL_APFM_ERROR	Indicates Anticipated Pre-Fetch Mechanism error: happens when 2 consecutive events are programmed, and when the first event is not completely finished while second pre-fetch instant is reached. 0: No error 1: Error occurred	0x0
6	R	EVT_SCHDL_APFM_ERROR	Indicates Anticipated Pre-Fetch Mechanism error: happens when 2 consecutive events are programmed, and when the first event is not completely finished while second pre-fetch instant is reached. 0: No error 1: Error occurred	0x0
5	R	EVT_SCHDL_ENTRY_ERROR	Indicates Event Scheduler faced Invalid timing programming on two consecutive ET entries (e.g first one with 624s offset and second one with no offset) 0: No error 1: Error occurred	0x0
4	R/W	EVT_SCHDL_EMACC_ERROR	Indicates Event Scheduler Exchange Memory access error, happens when Exchange Memory accesses are not served in time, and blocks the Exchange Table entry read 0: No error 1: Error occurred	0x0
3	R	RADIO_EMACC_ERROR	Indicates Radio Controller Exchange Memory access error, happens when Exchange Memory accesses are not served in time and data are corrupted. 0: No error 1: Error occurred	0x0
2	R	PKTCNTL_EMACC_ERROR	Indicates Packet Controller Exchange Memory access error, happens when Exchange Memory accesses are not served in time and Tx/Rx data are corrupted 0: No error 1: Error occurred	0x0
1	R	RXCRYPT_ERROR	Indicates real time decryption error, happens when AES-CCM decryption is too slow compared to Packet Controller requests. A 16-bytes block has to be decrypted prior the next block is received by the Packet Controller 0: No error 1: Error occurred	0x0
0	R	TXCRYPT_ERROR	Indicates Real Time encryption error, happens when AES-CCM encryption is too slow compared to Packet Controller requests. A 16-bytes block has to be encrypted and prepared on Packet Controller request, and needs to be ready before the Packet Controller has to send it 0: No error 1: Error occurred	0x0

Table 116: BLE_SWPROFILING_REG (0x40000064)

Bit	Mode	Symbol	Description	Reset
31:0	R/W	SWPROFVAL	Software Profiling register: used by RW-BLE Software for profiling purpose: this value is copied on Diagnostic port	0x0

Table 117: BLE_RADIOCNTRL0_REG (0x40000070)

Bit	Mode	Symbol	Description	Reset
31:0	-	-	Reserved	0x0

Table 118: BLE_RADIOCNTRL1_REG (0x40000074)

Bit	Mode	Symbol	Description	Reset
20:16	R/W	XRFSEL	Extended radio selection field, Must be set to "2".	0x0

Table 119: BLE_RADIOCNTRL2_REG (0x40000078)

Bit	Mode	Symbol	Description	Reset
31:0	-	-	Reserved	0x0

Table 120: BLE_RADIOCNTRL3_REG (0x4000007C)

Bit	Mode	Symbol	Description	Reset
31:0	-	-	Reserved	0x0

Table 121: BLE_RADIOPWUPDN_REG (0x40000080)

Bit	Mode	Symbol	Description	Reset
30:24	R/W	RTRIP_DELAY	Defines round trip delay value. This value correspond to the addition of data latency in Tx and data latency in Rx. Value is in us	0x0
23:16	R/W	RXPWRUP	This register holds the length in s of the RX power up phase for the current radio device. Default value is 210us (reset value). Operating range depends on the selected radio.	0xD2
11:8	R/W	TXPWRDN	This register extends the length in s of the TX power down phase for the current radio device. Default value is 3us (reset value). Operating range depends on the selected radio.	0x3
7:0	R/W	TXPWRUP	This register holds the length in s of the TX power up phase for the current radio device. Default value is 210us (reset value). Operating range depends on the selected radio.	0xD2

Table 122: BLE_ADVCHMAP_REG (0x40000090)

Bit	Mode	Symbol	Description	Reset
2:0	R/W	ADVCHMAP	Advertising Channel Map, defined as per the advertising connection settings. Contains advertising channels index 37 to 39. If ADVCHMAP[i] equals: 0: Do not use data channel i+37. 1: Use data channel i+37.	0x7

Table 123: BLE_ADVTIM_REG (0x400000A0)

Bit	Mode	Symbol	Description	Reset
13:0	R/W	ADVINT	Advertising Packet Interval defines the time interval in between two ADV_xxx packet sent. Value is in us. Value to program depends on the used Advertising Packet type and the device filtering policy.	0x0

Table 124: BLE_ACTSCANSTAT_REG (0x400000A4)

Bit	Mode	Symbol	Description	Reset
24:16	R	BACKOFF	Active scan mode back-off counter initialization value.	0x1
8:0	R	UPPERLIMIT	Active scan mode upper limit counter value.	0x1

Table 125: BLE_WLPUBADDPTR_REG (0x400000B0)

Bit	Mode	Symbol	Description	Reset
15:0	R/W	WLPUBADDPTR	Start address pointer of the public devices white list.	0x0

Table 126: BLE_WLPRIVADDPTR_REG (0x400000B4)

Bit	Mode	Symbol	Description	Reset
15:0	R/W	WLPRIVADDPTR	Start address pointer of the private devices white list.	0x0

Table 127: BLE_WLNBDEV_REG (0x400000B8)

Bit	Mode	Symbol	Description	Reset
15:8	R/W	NBPRIVDEV	Number of private devices in the white list.	0x0
7:0	R/W	NBPUBDEV	Number of public devices in the white list.	0x0

Table 128: BLE_AESCNTL_REG (0x400000C0)

Bit	Mode	Symbol	Description	Reset
1	R/W	AES_MODE	0: Cipher mode 1: Decipher mode	0x0
0	R0/W	AES_START	Writing a 1 starts AES-128 ciphering/deciphering process. This bit is reset once the process is finished (i.e. ble_crypt_irq interrupt occurs, even masked)	0x0

Table 129: BLE_AESKEY31_0_REG (0x400000C4)

Bit	Mode	Symbol	Description	Reset
31:0	R/W	AESKEY31_0	AES encryption 128-bit key. Bit 31 down to 0	0x0

Table 130: BLE_AESKEY63_32_REG (0x400000C8)

Bit	Mode	Symbol	Description	Reset
31:0	R/W	AESKEY63_32	AES encryption 128-bit key. Bit 63 down to 32	0x0

Table 131: BLE_AESKEY95_64_REG (0x400000CC)

Bit	Mode	Symbol	Description	Reset
31:0	R/W	AESKEY95_64	AES encryption 128-bit key. Bit 95 down to 64	0x0

Table 132: BLE_AESKEY127_96_REG (0x400000D0)

Bit	Mode	Symbol	Description	Reset
31:0	R/W	AESKEY127_96	AES encryption 128-bit key. Bit 127 down to 96	0x0

Table 133: BLE_AESPTR_REG (0x400000D4)

Bit	Mode	Symbol	Description	Reset
15:0	R/W	AESPTR	Pointer to the memory zone where the block to cipher/decipher using AES-128 is stored.	0x0

Table 134: BLE_TXMICVAL_REG (0x400000D8)

Bit	Mode	Symbol	Description	Reset
31:0	R	TXMICVAL	AES-CCM plain MIC value. Valid on when MIC has been calculated (in Tx)	0x0

Table 135: BLE_RXMICVAL_REG (0x400000DC)

Bit	Mode	Symbol	Description	Reset
31:0	R	RXMICVAL	AES-CCM plain MIC value. Valid on once MIC has been extracted from Rx packet.	0x0

Table 136: BLE_RFTESTCNTL_REG (0x400000E0)

Bit	Mode	Symbol	Description	Reset
31	R/W	INFINITERX	Applicable in RF Test Mode only 0: Normal mode of operation 1: Infinite Rx window	0x0
27	R/W	RXPKTCNTEN	Applicable in RF Test Mode only 0: Rx packet count disabled 1: Rx packet count enabled, and reported in CS-RXCCMPKTCNT and RFTESTRXSTAT-RXPKTCNT on RF abort command	0x0
15	R/W	INFINITETX	Applicable in RF Test Mode only 0: Normal mode of operation. 1: Infinite Tx packet / Normal start of a packet but endless payload	0x0
14	R/W	TXLENGTHSRC	Applicable only in Tx/Rx RF Test mode 0: Normal mode of operation: TxDESC-TXADVLEN controls the Tx packet payload size 1: Uses RFTESTCNTL-TXLENGTH packet length (can support up to 512 bytes transmit)	0x0
13	R/W	PRBSTYPE	Applicable only in Tx/Rx RF Test mode 0: Tx Packet Payload are PRBS9 type 1: Tx Packet Payload are PRBS15 type	0x0
12	R/W	TXPLDSRC	Applicable only in Tx/Rx RF Test mode 0: Tx Packet Payload source is the Control Structure 1: Tx Packet Payload are PRBS generator	0x0
11	R/W	TXPKTCNTEN	Applicable in RF Test Mode only 0: Tx packet count disabled 1: Tx packet count enabled, and reported in CS-TXCCMPKTCNT and RFTESTTXSTAT-TXPKTCNT on RF abort command	0x0
8:0	R/W	TXLENGTH	Applicable only for Tx/Rx RF Test mode, and valid when RFTESTCNTL-TXLENGTHSRC = 1 Tx packet length in number of byte	0x0

Table 137: BLE_RFTESTTXSTAT_REG (0x400000E4)

Bit	Mode	Symbol	Description	Reset
31:0	R/W	TXPKTCNT	Reports number of transmitted packet during Test Modes. Value is valid if RFTESTCNTL-TXPKTCNTEN is set	0x0

Table 138: BLE_RFTESTRXSTAT_REG (0x400000E8)

Bit	Mode	Symbol	Description	Reset
31:0	R/W	RXPKTCNT	Reports number of correctly received packet during Test Modes (no sync error, no CRC error). Value is valid if RFTESTCNTL-RXPKTCNTEN is set	0x0

Table 139: BLE_TIMGENCNTL_REG (0x400000F0)

Bit	Mode	Symbol	Description	Reset
31	R/W	APFM_EN	Controls the Anticipated pre-Fetch Abort mechanism 0: Disabled 1: Enabled	0x1
25:16	R/W	PREFETCHABORT_TIME	Defines the instant in s at which immediate abort is required after anticipated pre-fetch abort	0x1FE
8:0	R/W	PREFETCH_TIME	Defines Exchange Table pre-fetch instant in us	0x96

Table 140: BLE_GROSSTIMTGT_REG (0x400000F4)

Bit	Mode	Symbol	Description	Reset
22:0	R/W	GROSSTARGET	Gross Timer Target value on which a ble_grosstgtim_irq must be generated. This timer has a precision of 10ms: interrupt is generated only when GROSSTARGET[22:0] = BASETIMECNT[26:4] and BASETIMECNT[3:0] = 0.	0x0

Table 141: BLE_FINETIMTGT_REG (0x400000F8)

Bit	Mode	Symbol	Description	Reset
26:0	R/W	FINETARGET	Fine Timer Target value on which a ble_finetgtim_irq must be generated. This timer has a precision of 625us: interrupt is generated only when FINETARGET = BASETIMECNT	0x0

Table 142: BLE_SAMPLECLK_REG (0x400000FC)

Bit	Mode	Symbol	Description	Reset
0	R0/W	SAMP	Writing a 1 samples the Base Time Counter value in BASETIMECNT register. Resets at 0 when action is performed.	0x0

Table 143: BLE_COEXIFCNTL0_REG (0x40000100)

Bit	Mode	Symbol	Description	Reset
21:20	R/W	WLCRXPRIOMODE	Defines Bluetooth Low Energy packet ble_rx mode behavior. 00: Rx indication excluding Rx Power up delay (starts when correlator is enabled) 01: Rx indication including Rx Power up delay 10: Rx High priority indicator 11: n/a	0x0

Table 143: BLE_COEXIFCNTL0_REG (0x40000100)

Bit	Mode	Symbol	Description	Reset
17:16	R/W	WLCTXPRIOMODE	Defines Bluetooth Low Energy packet ble_tx mode behavior 00: Tx indication excluding Tx Power up delay 01: Tx indication including Tx Power up delay 10: Tx High priority indicator 11: n/a	0x0
7:6	R/W	WLANTXMSK	Determines how wlan_tx impact BLE Tx and Rx 00: wlan_tx has no impact (default mode) 01: wlan_tx can stop BLE Tx, no impact on BLE Rx 10: wlan_tx can stop BLE Rx, no impact on BLE Tx 11: wlan_tx can stop both BLE Tx and BLE Rx	0x0
5:4	R/W	WLANRXMSK	Determines how wlan_rx impact BLE Tx and Rx 00: wlan_rx has no impact 01: wlan_rx can stop BLE Tx, no impact on BLE Rx (default mode) 10: wlan_rx can stop BLE Rx, no impact on BLE Tx 11: wlan_rx can stop both BLE Tx and BLE Rx	0x0
1	R/W	SYNCGEN_EN	Determines whether ble_sync is generated or not. 0: ble_sync pulse not generated 1: ble_sync pulse generated	0x0
0	R/W	COEX_EN	Enable / Disable control of the MWS/WLAN Coexistence control 0: Coexistence interface disabled 1: Coexistence interface enabled	0x0

Table 144: BLE_COEXIFCNTL1_REG (0x40000104)

Bit	Mode	Symbol	Description	Reset
28:24	R/W	WLCPRXTHR	Applies on ble_rx if WLCRXPRIOMODE equals 10 Determines the threshold for Rx priority setting. If ble_pti[3:0] output value is greater than WLCPRXTHR, then Rx Bluetooth Low Energy priority is considered as high, and must be provided to the WLAN coexistence interface	0x0
20:16	R/W	WLCPTXTHR	Applies on ble_tx if WLCTXPRIOMODE equals 10 Determines the threshold for priority setting. If ble_pti[3:0] output value is greater than WLCPTXTHR, then Tx Bluetooth Low Energy priority is considered as high, and must be provided to the WLAN coexistence interface	0x0
14:8	R/W	WLCPDURATION	Applies on ble_tx if WLCTXPRIOMODE equals 10 Applies on ble_rx if WLCRXPRIOMODE equals 10 Determines how many s the priority information must be maintained Note that if WLCPDURATION = 0x00, then Tx/Rx priority levels are maintained till Tx/Rx EN are de-asserted.	0x0
6:0	R/W	WLCPDELAY	Applies on ble_tx if WLCTXPRIOMODE equals 10. Applies on ble_rx if WLCRXPRIOMODE equals 10. Determines the delay (in us) in Tx/Rx enables rises the time Bluetooth Low energy Tx/Rx priority has to be provided .	0x0

Table 145: BLE_BLEMPRIO0_REG (0x40000108)

Bit	Mode	Symbol	Description	Reset
31:28	R/W	BLEM7	Set Priority value for Passive Scanning	0x3
27:24	R/W	BLEM6	Set Priority value for Non-Connectable Advertising	0x4
23:20	R/W	BLEM5	Set Priority value for Connectable Advertising BLE message	0x4

Table 145: BLE_BLEMPRIO0_REG (0x40000108)

Bit	Mode	Symbol	Description	Reset
19:16	R/W	BLEM4	Set Priority value for Active Scanning BLE message	0x9
15:12	R/W	BLEM3	Set Priority value for Initiating (Scanning) BLE message	0xA
11:8	R/W	BLEM2	Set Priority value for Data Channel transmission BLE message	0xD
7:4	R/W	BLEM1	Set Priority value for LLCP BLE message	0xE
3:0	R/W	BLEM0	Set Priority value for Initiating (Connection Request Response) BLE message	0xF

Table 146: BLE_BLEMPRIO1_REG (0x4000010C)

Bit	Mode	Symbol	Description	Reset
31:28	R/W	BLEMDEFAULT	Set default priority value for other BLE message than those defined above	0x3

Table 147: BLE_BLEPRIOSCHARB_REG (0x40000110)

Bit	Mode	Symbol	Description	Reset
15	R/W	BLEPRIOMODE	Determine BLE Priority Scheduling Arbitration Mode 0: BLE Decision instant not used 1: BLE Decision instant used	0x0
7:0	R/W	BLEMARGIN	Determine the decision instant margin for Priority Scheduling Arbitration.	0x0

Table 148: BLE_CNTL2_REG (0x40000200)

Bit	Mode	Symbol	Description	Reset
31:22	-	-	Reserved	0x0
21	R/W	BLE_RSSI_SEL	0: Select Peak-hold RSSI value (default). 1: Select current Average RSSI value.	0x0
20	R/W	WAKEUPLPSTAT	The status of the BLE_WAKEUP_LP_IRQ. The Interrupt Service Routine of BLE_WAKEUP_LP_IRQ should return only when the WAKEUPLPSTAT is cleared. Note that BLE_WAKEUP_LP_IRQ is automatically acknowledged after the power up of the Radio Subsystem, plus one Low Power Clock period.	0x0
19	R/W	SW_RPL_SPI	Keep to 0.	0x0
18:15	-	-	Reserved	0x0
14:9	R/W	BLE_CLK_SEL	BLE Clock Select. Specifies the BLE master clock absolute frequency in MHz. Typical values are 16 and 8. Value depends on the selected XTAL frequency and the value of CLK_RADIO_REG[BLE_DIV] bitfield. For example, if XTAL oscillates at 16MHz and CLK_RADIO_REG[BLE_DIV] = 1 (divide by 2), then BLE master clock frequency is 8MHz and BLE_CLK_SEL should be set to value 8. The selected BLE master clock frequency (affected by BLE_DIV and BLE_CLK_SEL) must be modified and set only during the initialization time, i.e. before setting BLE_RWBTLCTRL_REG[RWBLE_EN] to 1. Refer also to BLE_RWBTLCONF_REG[CLK_SEL].	0x0

Table 148: BLE_CNTL2_REG (0x40000200)

Bit	Mode	Symbol	Description	Reset
8	R/W	RADIO_PWRDN_ALLOW	This active high signal indicates when it is allowed for the BLE core (embedded in the Radio sub-System power domain) to be powered down. After the assertion of the BLE_DEEPSLCTRL_REG[DEEP_SLEEP_ON] a hardware sequence based on the Low Power clock will cause the assertion of RADIO_PWRDN_ALLOW. The RADIO_PWRDN_ALLOW will be cleared to "0" when the BLE core exits from the sleep state, i.e. when the BLE_SLP_IRQ will be asserted.	0x0
7	R/W	MON_LP_CLK	The SW can only write a "0" to this bit. Whenever a positive edge of the low power clock used by the BLE Timers is detected, then the HW will automatically set this bit to "1". This functionality will not work if BLE Timer is in reset state (refer to CLK_RADIO_REG[BLE_LP_RESET]). This bit can be used for SW synchronization, to debug the low power clock, etc.	0x0
6	R/W	BLE_CLK_STAT	0: BLE uses low power clock 1: BLE uses master clock	0x0
5:3	-	-	Reserved	0x0
2	R/W	EMACCERRMSK	Exchange Memory Access Error Mask: When cleared to "0" the EM_ACC_ERR will not cause an BLE_ERROR_IRQ interrupt. When set to "1" an BLE_ERROR_IRQ will be generated as long as EM_ACC_ERR is "1".	0x0
1	R/W	EMACCERRACK	Exchange Memory Access Error Acknowledge. When the SW writes a "1" to this bit then the EMACCERRSTAT bit will be cleared. When the SW writes "0" it will have no affect. The read value is always "0".	0x0
0	R/W	EMACCERRSTAT	Exchange Memory Access Error Status: The bit is read-only and can be cleared only by writing a "1" at EMACCERRACK bitfield. This bit will be set to "1" by the hardware when the controller will access an EM page that is not mapped according to the EM_MAPPING value. When this bit is "1" then the BLE_ERROR_IRQ will be asserted as long as EMACCERRMSK is "1".	0x0

Table 149: BLE_EM_BASE_REG (0x40000208)

Bit	Mode	Symbol	Description	Reset
31:17	-	-	Reserved	0x0
16:10	R/W	BLE_EM_BASE_16_10	The physical address on the system memory map of the base of the Exchange Memory.	0x0
9:0	-	-	Reserved	0x0

Table 150: BLE_DIAGCTRL2_REG (0x4000020C)

Bit	Mode	Symbol	Description	Reset
-	-	-	Undefined	-

Table 151: BLE_DIAGCNTL3_REG (0x40000210)

Bit	Mode	Symbol	Description	Reset
-	-	-	Undefined	-

37.4 AES_HASH REGISTER FILE

Table 152: Register map AES_HASH

Address	Port	Description
0x40020000	CRYPTO_CTRL_REG	Crypto Control register
0x40020004	CRYPTO_START_REG	Crypto Start calculation
0x40020008	CRYPTO_FETCH_ADDR_REG	Crypto DMA fetch register
0x4002000C	CRYPTO_LEN_REG	Crypto Length of the input block in bytes
0x40020010	CRYPTO_DEST_ADDR_REG	Crypto DMA destination memory
0x40020014	CRYPTO_STATUS_REG	Crypto Status register
0x40020018	CRYPTO_CLRIRQ_REG	Crypto Clear interrupt request
0x4002001C	CRYPTO_MREG0_REG	Crypto Mode depended register 0
0x40020020	CRYPTO_MREG1_REG	Crypto Mode depended register 1
0x40020024	CRYPTO_MREG2_REG	Crypto Mode depended register 2
0x40020028	CRYPTO_MREG3_REG	Crypto Mode depended register 3
0x40020100	CRYPTO_KEYS_START	Crypto First position of the AES keys storage memory

Table 153: CRYPTO_CTRL_REG (0x40020000)

Bit	Mode	Symbol	Description	Reset
31:18	-	-	Reserved	0x0
17	R/W	CRYPTO_AES_KEX_P	It forces (active high) the execution of the key expansion process with the starting of the AES encryption/decryption process. The bit will be cleared automatically by the hardware, after the completion of the AES key expansion process.	0x0
16	R/W	CRYPTO_MORE_IN	0 - Define that this is the last input block. When the current input is consumed by the crypto engine and the output data is written to the memory, the calculation ends (CRYPTO_INACTIVE goes to one). 1 - The current input data block is not the last. More input data will follow. When the current input is consumed, the engine stops and waits for more data (CRYPTO_WAIT_FOR_IN goes to one).	0x0
15:10	R/W	CRYPTO_HASH_OUTPUT_LEN	The number of bytes minus one of the hash result which will be saved at the memory by the DMA. In relation with the selected hash algorithm the accepted values are: MD5: 0..15 -> 1-16 bytes SHA-1: 0..19 -> 1-20 bytes SHA-256: 0..31 -> 1-32 bytes SHA-256/224: 0..27 -> 1-28 bytes SHA-384: 0..47 -> 1-48 bytes SHA-512: 0..63 -> 1-64 bytes SHA-512/224: 0..27 -> 1-28 bytes SHA-512/256: 0..31 -> 1-32 bytes	0x0
9	R/W	CRYPTO_HASH_SELECT	Selects the type of the algorithm 0 - The encryption algorithm (AES) 1 - A hash algorithm. The exact algorithm is defined by the fields CRYPTO_ALG and CRYPTO_ALG_MD.	0x0
8	R/W	CRYPTO_IRQ_EN	Interrupt Request Enable 0 - The interrupt generation ability is disabled. 1 - The interrupt generation ability is enabled. Generates an interrupt request at the end of operation.	0x0
7	R/W	CRYPTO_ENCDEC	Encryption/Decryption 0 - Decryption 1 - Encryption	0x0

Table 153: CRYPTO_CTRL_REG (0x40020000)

Bit	Mode	Symbol	Description	Reset
6:5	R/W	CRYPTO_AES_KEY_SZ	The size of AES Key 00 - 128 bits AES Key 01 - 192 bits AES Key 10 - 256 bits AES Key 11 - 256 bits AES Key	0x0
4	R/W	CRYPTO_OUT_MD	Output Mode. This field makes sense only when the AES algorithm is selected (CRYPTO_HASH_SEL = 0) 0 - Write back to memory all the resulting data 1 - Write back to memory only the final block of the resulting data	0x0
3:2	R/W	CRYPTO_ALG_MD	It defines the mode of operation of the AES algorithm when the controller is configured for an encryption/decryption processing (CRYPTO_HASH_SEL = 0). 00 - ECB 01 - ECB 10 - CTR 11 - CBC When the controller is configured to applies a HASH function, this field selects the desired HASH algorithm with the help of the CRYPTO_ALG. 00 - HASH algorithms that are based on 32 bits operations 01 - HASH algorithms that are based on 64 bits operations 10 - Reserved 11 - Reserved See also the CRYPTO_ALG field.	0x0
1:0	R/W	CRYPTO_ALG	Algorithm selection. When CRYPTO_HASH_SEL = 0 the only available choice is the AES algorithm. 00 - AES 01 - Reserved 10 - Reserved 11 - Reserved When CRYPTO_HASH_SEL = 1, this field selects the desired hash algorithms, with the help of the CRYPTO_ALG_MD field. If CRYPTO_ALG_MD = 00 00 - MD5 01 - SHA-1 10 - SHA-256/224 11 - SHA-256 If CRYPTO_ALG_MD = 01 00 - SHA-384 01 - SHA-512 10 - SHA-512/224 11 - SHA-512/256	0x0

Table 154: CRYPTO_START_REG (0x40020004)

Bit	Mode	Symbol	Description	Reset
31:1	-	-	Reserved	0x0
0	R0/W	CRYPTO_START	Write 1 to initiate the processing of the input data. This register is auto-cleared.	0x0

Table 155: CRYPTO_FETCH_ADDR_REG (0x40020008)

Bit	Mode	Symbol	Description	Reset
31:0	R/W	CRYPTO_FETCH_ADDR	The memory address from where will be retrieved the data that will be processed. The value of this register is updated as the calculation proceeds and the output data are written to the memory.	0x0

Table 156: CRYPTO_LEN_REG (0x4002000C)

Bit	Mode	Symbol	Description	Reset
31:24	-	-	Reserved	0x0
23:0	R/W	CRYPTO_LEN	It contains the number of bytes of input data. If this number is not a multiple of a block size, the data is automatically extended with zeros. The value of this register is updated as the calculation proceeds and the output data are written to the memory.	0x0

Table 157: CRYPTO_DEST_ADDR_REG (0x40020010)

Bit	Mode	Symbol	Description	Reset
31:0	R/W	CRYPTO_DEST_ADDR	Destination address at where the result of the processing is stored. The value of this register is updated as the calculation proceeds and the output data are written to the memory.	0x0

Table 158: CRYPTO_STATUS_REG (0x40020014)

Bit	Mode	Symbol	Description	Reset
31:3	-	-	Reserved	0x0
2	R	CRYPTO_IRQ_ST	The status of the interrupt request line of the CRYPTO block. 0 - There is no active interrupt request. 1 - An interrupt request is pending.	0x0
1	R	CRYPTO_WAIT_FOR_IN	Indicates the situation where the engine waits for more input data. This is applicable when the CRYPTO_MORE_IN= 1, so the input data are fragmented in the memory. 0 - The crypto is not waiting for more input data. 1 - The crypto waits for more input data. The CRYPTO_INACTIVE flag remains to zero to indicate that the calculation is not finished. The supervisor of the CRYPTO must program to the CRYPTO_FETCH_ADDR and CRYPTO_LEN a new input data fragment. The calculation will be continued as soon as the CRYPTO_START register will be written with 1. This action will clear the CRYPTO_WAIT_FOR_IN flag.	0x0
0	R	CRYPTO_INACTIVE	0 - The CRYPTO is active. The processing is in progress. 1 - The CRYPTO is inactive. The processing has finished.	0x1

Table 159: CRYPTO_CLRIRQ_REG (0x40020018)

Bit	Mode	Symbol	Description	Reset
31:1	-	-	Reserved	0x0
0	R0/W	CRYPTO_CLRIRQ	Write 1 to clear a pending interrupt request.	0x0

Table 160: CRYPTO_MREG0_REG (0x4002001C)

Bit	Mode	Symbol	Description	Reset
31:0	R/W	CRYPTO_MREG0	It contains information that are depended by the mode of operation, when is used the AES algorithm: CBC - IV[31:0] CTR - CTRBLK[31:0]. It is the initial value of the 32 bits counter. At any other mode, the contents of this register has no meaning.	0x0

Table 161: CRYPTO_MREG1_REG (0x40020020)

Bit	Mode	Symbol	Description	Reset
31:0	R/W	CRYPTO_MREG1	It contains information that are depended by the mode of operation, when is used the AES algorithm: CBC - IV[63:32] CTR - CTRBLK[63:32] At any other mode, the contents of this register has no meaning.	0x0

Table 162: CRYPTO_MREG2_REG (0x40020024)

Bit	Mode	Symbol	Description	Reset
31:0	R/W	CRYPTO_MREG2	It contains information that are depended by the mode of operation, when is used the AES algorithm: CBC - IV[95:64] CTR - CTRBLK[95:64] At any other mode, the contents of this register has no meaning.	0x0

Table 163: CRYPTO_MREG3_REG (0x40020028)

Bit	Mode	Symbol	Description	Reset
31:0	R/W	CRYPTO_MREG3	It contains information that are depended by the mode of operation, when is used the AES algorithm: CBC - IV[127:96] CTR - CTRBLK[127:96] At any other mode, the contents of this register has no meaning.	0x0

Table 164: CRYPTO_KEYS_START (0x40020100)

Bit	Mode	Symbol	Description	Reset
31:0	W	CRYPTO_KEY_X	CRYPTO_KEY_(0-63) This is the AES keys storage memory. This memory is accessible via AHB slave interface, only when the CRYPTO is inactive (CRYPTO_INACTIVE = 1).	0x0

37.5 CACHE REGISTER FILE

Table 165: Register map CACHE

Address	Port	Description
0x400C3000	CACHE_CTRL1_REG	Cache control register 1
0x400C3004	CACHE_LNSIZECFG_REG	Cache line size configuration register
0x400C3008	CACHE ASSOCCFG_REG	Cache associativity configuration register
0x400C3020	CACHE_CTRL2_REG	Cache control register 2
0x400C3028	CACHE_MRM_HITS_REG	Cache MRM (Miss Rate Monitor) HITS register
0x400C302C	CACHE_MRM_MISSES_REG	Cache MRM (Miss Rate Monitor) MISSES register
0x400C3030	CACHE_MRM_CTRL_REG	Cache MRM (Miss Rate Monitor) CONTROL register
0x400C3034	CACHE_MRM_TINT_REG	Cache MRM (Miss Rate Monitor) TIME INTERVAL register
0x400C3038	CACHE_MRM_THRES_REG	Cache MRM (Miss Rate Monitor) THRESHOLD register
0x400C3050	SWD_RESET_REG	SWD HW reset control register

Table 166: CACHE_CTRL1_REG (0x400C3000)

Bit	Mode	Symbol	Description	Reset
31:2	-	-	Reserved	0
1	R/W	CACHE_RES1	Reserved. Always keep 0.	0
0	R0/W	CACHE_FLUSH	Writing a '1' into this bit, flushes the contents of the tag memories which invalidates the content of the cache memory. The read of this bit is always '0'. Note: The flushing of the cache TAG memory takes 0x100 or 0x200 HCLK cycles for a Cache Data RAM size of 8 KB resp. 16 KB.	0

Table 167: CACHE_LNSIZECFG_REG (0x400C3004)

Bit	Mode	Symbol	Description	Reset
31:2	-	-	Reserved	0
1:0	R/W	CACHE_LINE	Cache line size: 0: 8 bytes, 1: 16 bytes, 2: 32 bytes, 3: reserved. Note: Flush the cache just after the dynamic (run-time) reconfiguration of the cache with an 8 bytes cache line size: write the value "01" into the cache control register CACHE_CTRL1_REG just after the write of the value "00" into the cache line size configuration register CACHE_LNSIZECFG_REG.	0

Table 168: CACHE ASSOCCFG_REG (0x400C3008)

Bit	Mode	Symbol	Description	Reset
31:2	-	-	Reserved	0

Table 168: CACHE ASSOCCFG_REG (0x400C3008)

Bit	Mode	Symbol	Description	Reset
1:0	R/W	CACHE_ASSOC	Cache associativity: 0: 1-way (direct mapped) 1: 2-way 2: 4-way 3: reserved. Note: Flush the cache controller <u>before</u> dynamically decreasing the associativity.	2

Table 169: CACHE_CTRL2_REG (0x400C3020)

Bit	Mode	Symbol	Description	Reset
31:13	-	-	Reserved	0
12	R/W	ENABLE_ALSO_QS PIFLASH_CACHED	Enable also the QSPI FLASH cacheability when remapped to OTP (cached). See also the notes at "CACHE_LEN".	0
11	R/W	ENABLE_ALSO_OT P_CACHED	Enable also the OTP cacheability when remapped to QSPI FLASH (cached). See also the notes at "CACHE_LEN".	0
10	R/W	CACHE_CGEN	0: Cache controller clock gating is not enabled. 1: Cache controller clock gating is enabled (enabling power saving). Note: This bit must be set to '0' (default) when setting the CACHE_FLUSH bit while executing from other than QSPI FLASH cached or OTP cached, e.g. from Booter or SYS-RAM.	0
9	R/W	CACHE_WEN	0: Cache Data and TAG memory read only. 1: Cache Data and TAG memory read/write. The TAG and Data memory are only updated by the cache controller. There is no HW protection to prevent unauthorized access by the ARM. Note: When accessing the memory mapped Cache Data and TAG memory (for debugging purposes) only 32 bits access is allowed to the Cache Data memory and only 16 bits access is allowed to the Cache TAG memory.	0
8:0	R/W	CACHE_LEN	Length of QSPI FLASH cacheable memory. (N+1)*64kbyte. N= 0 to 512 (Max of 32 Mbyte). Setting CACHE_LEN=0 disables the cache. Note 1: The OTP memory is completely cacheable (when enabled). Note 2: The max. size/length of QSPI FLASH cacheable memory is 16 Mbyte when also OTP is cached.	0

Table 170: CACHE_MRM_HITS_REG (0x400C3028)

Bit	Mode	Symbol	Description	Reset
31:19	-	-	Reserved	0
18:0	R/W	MRM_HITS	Contains the amount of cache hits.	0

Table 171: CACHE_MRM_MISSES_REG (0x400C302C)

Bit	Mode	Symbol	Description	Reset
31:18	-	-	Reserved	0

Table 171: CACHE_MRM_MISSES_REG (0x400C302C)

Bit	Mode	Symbol	Description	Reset
17:0	R/W	MRM_MISSES	Contains the amount of cache misses.	0

Table 172: CACHE_MRM_CTRL_REG (0x400C3030)

Bit	Mode	Symbol	Description	Reset
31:4	-	-	Reserved	0
3	R/W	MRM_IRQ_THRES_STATUS	0: No interrupt is generated. 1: Interrupt (pulse-sensitive) is generated because the number of cache misses reached the programmed threshold (threshold != 0).	0
2	R/W	MRM_IRQ_TINT_STATUS	0: No interrupt is generated. 1: Interrupt (pulse-sensitive) is generated because the time interval counter reached the end (time interval != 0).	0
1	R/W	MRM_IRQ_MASK	0: Disables interrupt generation. 1: Enables interrupt generation. Note: The Cache MRM generates a pulse-sensitive interrupt towards the ARM processor,	0
0	R/W	MRM_START	0: Freeze the "misses/hits" counters and reset the time interval counter to the programmed value in CACHE_MRM_TINT_REG. 1: Enables the counters. Note: In case CACHE_MRM_CTRL_REG[MRM_START] is set to '1' and CACHE_MRM_TINT_REG (!=0) is used for the MRM interrupt generation, the time interval counter counts down (on a fixed reference clock of 16 MHz) until it's '0'. At that time CACHE_MRM_CTRL_REG[MRM_START] will be reset automatically to '0' by the MRM hardware and the MRM interrupt will be generated.	0

Table 173: CACHE_MRM_TINT_REG (0x400C3034)

Bit	Mode	Symbol	Description	Reset
31:18	-	-	Reserved	0
17:0	R/W	MRM_TINT	Defines the time interval for the monitoring in 16 MHz clock cycles. See also the description of CACHE_MRM_CTRL_REG[MRM_IRQ_TINT_STATUS]. Note: When MRM_TINT=0 (unrealistic value), no interrupt will be generated.	0

Table 174: CACHE_MRM_THRES_REG (0x400C3038)

Bit	Mode	Symbol	Description	Reset
31:18	-	-	Reserved	0
17:0	R/W	MRM_THRES	Defines the threshold to trigger the interrupt generation. See also the description of CACHE_MRM_CTRL_REG[MRM_IRQ_THRES_STATUS]. Note: When MRM_THRES=0 (unrealistic value), no interrupt will be generated.	0

Table 175: SWD_RESET_REG (0x400C3050)

Bit	Mode	Symbol	Description	Reset
31:1	-	-	Reserved	0

Table 175: SWD_RESET_REG (0x400C3050)

Bit	Mode	Symbol	Description	Reset
0	R0/W	SWD_HW_RESET_REQ	0: default. 1: HW reset request without resetting the SWD and DAP controller. The register is automatically reset with a HW_RESET. This bit can only be accessed by the debugger software and not by the application.	0

37.6 CRG REGISTER FILE

Table 176: Register map CRG

Address	Port	Description
0x50000000	CLK_AMBA_REG	HCLK, PCLK, divider and clock gates
0x50000002	CLK_FREQ_TRIM_REG	Xtal frequency trimming register.
0x50000008	CLK_RADIO_REG	Radio PLL control register
0x5000000A	CLK_CTRL_REG	Clock control register
0x5000000C	CLK_TMR_REG	Clock control for the timers
0x50000010	PMU_CTRL_REG	Power Management Unit control register
0x50000012	SYS_CTRL_REG	System Control register
0x50000014	SYS_STAT_REG	System status register
0x50000020	CLK_32K_REG	32 kHz oscillator register
0x50000022	CLK_16M_REG	16 MHz RC and xtal oscillator register
0x50000024	CLK_RCX20K_REG	20KHz RXC-oscillator control register
0x50000028	BANDGAP_REG	bandgap trimming
0x5000002A	ANA_STATUS_REG	status bit of analog (power management) circuits
0x50000030	VBUS_IRQ_MASK_REG	IRQ masking
0x50000032	VBUS_IRQ_CLEAR_REG	Clear pending IRQ register
0x50000034	BOD_CTRL_REG	Brown Out Detection control register
0x50000036	BOD_CTRL2_REG	Brown Out Detection control register
0x50000038	BOD_STATUS_REG	Brown Out Detection status register
0x5000003A	LDO_CTRL1_REG	LDO control register
0x5000003C	LDO_CTRL2_REG	LDO control register
0x5000003E	SLEEP_TIMER_REG	Timer for regulated sleep
0x50000050	XTALRDY_CTRL_REG	Control register for XTALRDY IRQ

Table 177: CLK_AMBA_REG (0x50000000)

Bit	Mode	Symbol	Description	Reset
12	R/W	QSPI_ENABLE	Clock enable for QSPI controller	0x0
11:10	R/W	QSPI_DIV	QSPI divider 00 = divide by 1 01 = divide by 2 10 = divide by 4 11 = divide by 8	0x0
9	R/W	OTP_ENABLE	Clock enable for OTP controller	0x0
8	R/W	TRNG_CLK_ENABLE	Clock enable for TRNG block	0x0
7	R/W	ECC_CLK_ENABLE	Clock enable for ECC block	0x0
6	R/W	AES_CLK_ENABLE	Clock enable for AES crypto block	0x0
5:4	R/W	PCLK_DIV	APB interface clock, Cascaded with HCLK: 00 = divide hclk by 1 01 = divide hclk by 2 10 = divide hclk by 4 11 = divide hclk by 8	0x2
3	-	-	Reserved	0x0

Table 177: CLK_AMBA_REG (0x50000000)

Bit	Mode	Symbol	Description	Reset
2:0	R/W	HCLK_DIV	AHB interface and microprocessor clock. Source clock divided by: 000 = divide hclk by 1 001 = divide hclk by 2 010 = divide hclk by 4 011 = divide hclk by 8 1xx = divide hclk by 16	0x2

Table 178: CLK_FREQ_TRIM_REG (0x50000002)

Bit	Mode	Symbol	Description	Reset
10:8	R/W	COARSE_ADJ	Xtal frequency course trimming register. 0x0 = lowest frequency 0x7 = highest frequency Increment or decrement the binary value with 1. Wait approximately 200usec to allow the adjustment to settle.	0x0
7:0	R/W	FINE_ADJ	Xtal frequency fine trimming register. 0x00 = lowest frequency 0xFF = highest frequency	0x0

Table 179: CLK_RADIO_REG (0x50000008)

Bit	Mode	Symbol	Description	Reset
11	-	-	Reserved	0x0
9:8	-	-	Reserved	0x0
7	R/W	BLE_ENABLE	Enable the BLE core clocks. When the BLE system clock is disabled, either due to the CLK_RADIO_REG[BLE_ENABLE] or due to the PMU_CTRL_REG[BLE_SLEEP], then any access to the BLE Register file will issue a hard fault to the CPU.	0x0
6	R/W	BLE_LP_RESET	Reset for the BLE LP timer	0x1
5:4	R/W	BLE_DIV	Division factor for BLE core blocks, having as reference the DIVN clock: 00 = Divide by 1 01 = Divide by 2 10 = Divide by 4 11 = Divide by 8 The programmed frequency should not be lower than 8MHz, not faster than 16MHz and not faster than the programmed CPU clock frequency. Refer also to BLE_CNTL2_REG[BLE_CLK_SEL].	0x0
3	R/W	RFCU_ENABLE	Enable the RF control Unit clock	0x0
1:0	R/W	RFCU_DIV	Division factor for RF Control Unit 0x0 = divide by 1 0x1 = divide by 2 0x2 = divide by 4 0x3 = divide by 8 The programmed frequency must be exactly 8MHz.	0x0

Table 180: CLK_CTRL_REG (0x5000000A)

Bit	Mode	Symbol	Description	Reset
15	R	RUNNING_AT_PLL96M	Indicates that the PLL96MHz clock is used as clock, and may not be switched off	0x0
14	R	RUNNING_AT_XTAL16M	Indicates that the XTAL16M clock is used as clock, and may not be switched off	0x0
13	R	RUNNING_AT_RC16M	Indicates that the RC16M clock is used as clock	0x1
12	R	RUNNING_AT_32K	Indicates that either the RC32k or XTAL32k is being used as clock	0x0
9:8	R/W	CLK32K_SOURCE	Sets the clock source of the LowerPower clock '00': 32 KHz RC Oscillator '01': RCX Oscillator '10': XTAL32kHz, when using an external crystal i.c.w. the internal oscillator (set P20 and P21 to FUNC_XTAL32) '11': XTAL32kHz, when an external generator or MCU applies a square wave on P20 (set P20 to FUNC_GPIO)	0x0
6	R/W	DIVN_XTAL32M_MODE	Enables the DIVN divide-by-2, in case of a 32 MHz crystal (See also XTAL32M_MODE), to keep the DIVN clock at 16 MHz.	0x0
5	R/W	PLL_DIV2	Divides the PLL clock by 2 before being used	0x0
4	R/W	USB_CLK_SRC	Selects the USB source clock 0 : PLL clock, divided by 2 1 : HCLK	0x0
3	R/W	XTAL32M_MODE	Enables dividers in the XTAL for both the RF and the BB PLL.	0x0
2	R/W	XTAL16M_DISABLE	Setting this bit instantaneously disables the 16 MHz crystal oscillator. This bit may not be set to '1' when "RUNNING_AT_XTAL16M is '1' to prevent deadlock. After resetting this bit, wait for XTAL16_TRIM_READY to become '1' before switching to XTAL16 clock source.	0x0
1:0	R/W	SYS_CLK_SEL	Selects the clock source. 0x0 : XTAL16M (check the XTAL16_TRIM_READY bit!!) 0x1 : RC16M 0x2 : The Low Power clock is used 0x3 : The PLL96Mhz is used	0x1

Table 181: CLK_TMR_REG (0x5000000C)

Bit	Mode	Symbol	Description	Reset
14	R/W	P06_TMR1_PWM_MODE	Maps Timer1_pwm onto P0_6, when DEBUGGER_EN = '0'. This state is preserved during deep sleep, to allow PWM5 output on the pad during deep sleep.	0x0
13	R/W	WAKEUPCT_ENABLE	Enables the clock	0x0
12	R/W	BREATH_ENABLE	Enables the clock	0x0
11	R/W	TMR2_CLK_SEL	Selects the clock source 1 = DIV1 clock 0 = DIVN clock	0x0
10	R/W	TMR2_ENABLE	Enable timer clock	0x0

Table 181: CLK_TMR_REG (0x5000000C)

Bit	Mode	Symbol	Description	Reset
9:8	R/W	TMR2_DIV	Division factor for Timer 0x0 = divide by 1 0x1 = divide by 2 0x2 = divide by 4 0x3 = divide by 8	0x0
7	R/W	TMR1_CLK_SEL	Selects the clock source 1 = DIV1 clock 0 = DIVN clock	0x0
6	R/W	TMR1_ENABLE	Enable timer clock	0x0
5:4	R/W	TMR1_DIV	Division factor for Timer 0x0 = divide by 1 0x1 = divide by 2 0x2 = divide by 4 0x3 = divide by 8	0x0
3	R/W	TMR0_CLK_SEL	Selects the clock source 1 = DIV1 clock 0 = DIVN clock	0x0
2	R/W	TMR0_ENABLE	Enable timer clock	0x0
1:0	R/W	TMR0_DIV	Division factor for Timer 0x0 = divide by 1 0x1 = divide by 2 0x2 = divide by 4 0x3 = divide by 8	0x0

Table 182: PMU_CTRL_REG (0x50000010)

Bit	Mode	Symbol	Description	Reset
15	R/W	RETAIN_ECCRAM	Selects the retainability of the ECC RAM during deep sleep. '1' is retainable, '0' is power gated	0x0
14	R/W	RETAIN_CACHE	Selects the retainability of the cache block during deep sleep. '1' is retainable, '0' is power gated	0x0
13	R/W	ENABLE_CLKLESS	Selects the clockless sleep mode. Wakeup is done asynchronously. When set to '1', the lp_clk is stopped during deep sleep, until a wakeup event (not debounced) is detected by the WAKUPCT block. When set to '0', the lp_clk continues running, so the MAC counters keep on running. This mode cannot be combined with regulated sleep, so keep SLEEP_TIMER=0 when using ENABLE_CLKLESS.	0x0
12:8	R/W	RETAIN_RAM	Select the retainability of the 5 system memory RAM macros during deep sleep. '1' is retainable, '0' is power gated (4) is SYSRAM5 (3) is SYSRAM4 (2) is SYSRAM3 (1) is SYSRAM2 (0) is SYSRAM1	0x0
7:6	R/W	OTP_COPY_DIV	Sets the HCLK division during OTP mirroring	0x0
5	R/W	RESET_ON_WAKEUP	Perform a Hardware Reset after waking up. Booter will be started.	0x0
3	-	-	Reserved	0x1

Table 182: PMU_CTRL_REG (0x50000010)

Bit	Mode	Symbol	Description	Reset
2	R/W	BLE_SLEEP	Put the BLE in powerdown. When the BLE system clock is disabled, either due to the CLK_RADIO_REG[BLE_ENABLE] or due to the PMU_CTRL_REG[BLE_SLEEP], then any access to the BLE Register file will issue a hard fault to the CPU.	0x1
1	R/W	RADIO_SLEEP	Put the digital part of the radio in powerdown	0x1
0	R/W	PERIPH_SLEEP	Put all peripherals (I2C, UART, SPI, ADC) in powerdown	0x1

Table 183: SYS_CTRL_REG (0x50000012)

Bit	Mode	Symbol	Description	Reset
15	W	SW_RESET	Writing a '1' to this bit will generate a SW_RESET.	0x0
14	R/W	REMAP_INTVECT	0: normal operation 1: If ARM is in address range 0 to 0xFF then the address is remapped to SYS-RAM 0x07FC.0000 to 0x07FC.00FF. This allows to put the interrupt vector table to be placed in RAM while executing from QSPI	0x0
13	R/W	OTP_COPY	Enables OTP to SysRAM copy action after waking up PD_SYS	0x0
12	R/W	QSPI_INIT	Enables QSPI initialization after wakeup	0x0
11	R/W	DEV_PHASE	Sets the development phase mode, used in combination with OTP_COPY No copy action to SysRAM is done when the system wakes up. For emulating startup time, the OTP_COPY bit still needs to be set.	0x0
10	R/W	CACHERAM_MUX	Controls accessibility of Cache RAM: 0: the cache controller is bypassed, the cacheRAM is visible in the memory space next to the DataRAMs 1: the cache controller is enabled, the cacheRAM is not visible anymore in the memory space	0x0
9	R/W	TIMEOUT_DISABLE	Disables timeout in Power statemachine. By default, the statemachine continues if after 2 ms the blocks are not started up. This can be read back from ANA_STATUS_REG	0x0
7	R/W	DEBUGGER_ENABLE	Enable the debugger. This bit is set by the booter according to the OTP header. If not set, the SWDIO and SW_CLK can be used as gpio ports.	0x0
6	R/W	OTPC_RESET_REQ	Reset request for the OTP controller.	0x0
5	R/W	PAD_LATCH_EN	Latches the control signals of the pads for state retention in powerdown mode. 0 = Control signals are retained 1 = Latch is transparent, pad can be recontrolled	0x1
4:3	R/W	REMAP_RAMs	Defines the sequence of the 3 first DataRAMs in the memory space. DataRAM4, DataRAM5 and potentially CacheRAM, cannot not be reshuffled. 0x0: DataRAM1, DataRAM2, DataRAM3 0x1: DataRAM2, DataRAM1, DataRAM3 0x2: DataRAM3, DataRAM1, DataRAM2 0x3: DataRAM3, DataRAM2, DataRAM1	0x0

Table 183: SYS_CTRL_REG (0x50000012)

Bit	Mode	Symbol	Description	Reset
2:0	R/W	REMAP_ADR0	Controls which memory is located at address 0x0000 for execution. 0x0: ROM 0x1: OTP 0x2: FLASH 0x3: RAMS (for the exact configuration see REMAP_RAMs) 0x4: FLASH un-cached (for verification only) 0x5: OTP un-cached (for verification only) 0x6: Cache Data RAM (CACHERAM_MUX=0, for testing purposes only) Note 1: DWord (64 bits) access is not supported by the Cache Data RAM interface in mirrored mode (only 32, 16 and 8 bits). Note 2: DMA access is not supported by the Cache Data RAM interface when REMAP_ADR0=0x6.	0x0

Table 184: SYS_STAT_REG (0x50000014)

Bit	Mode	Symbol	Description	Reset
11	-	-	Reserved	0x0
10	-	-	Reserved	0x1
9	R	BLE_IS_UP	Indicates that PD_DBG is functional	0x0
8	R	BLE_IS_DOWN	Indicates that PD_DBG is in power down	0x1
7	-	-	Reserved	0x0
6	R	XTAL16_TRIM_READY	Indicates that XTAL trimming mechanism is ready, i.e. the trimming equals CLK_FREQ_TRIM_REG.	0x1
5	R	DBG_IS_ACTIVE	Indicates that a debugger is attached.	0x0
4	-	-	Reserved	0x0
3	R	PER_IS_UP	Indicates that PD_PER is functional	0x0
2	R	PER_IS_DOWN	Indicates that PD_PER is in power down	0x1
1	R	RAD_IS_UP	Indicates that PD_RAD is functional	0x0
0	R	RAD_IS_DOWN	Indicates that PD_RAD is in power down	0x1

Table 185: CLK_32K_REG (0x50000020)

Bit	Mode	Symbol	Description	Reset
12	R/W	XTAL32K_DISABLE_AMPREG	Setting this bit disables the amplitude regulation of the XTAL32kHz oscillator. Set this bit to '1' for an external clock to XTAL32Kp Keep this bit '0' with a crystal between XTAL32Kp and XTAL32Km	0x0
11:8	R/W	RC32K_TRIM	0000 = lowest frequency 0111 = default 1111 = highest frequency	0x7
7	R/W	RC32K_ENABLE	Enables the 32kHz RC oscillator	0x1
6:3	R/W	XTAL32K_CUR	Bias current for the 32kHz XTAL oscillator. 0000 is minimum, 1111 is maximum, 0011 is default. For each application there is an optimal setting for which the start-up behavior is optimal	0x3

Table 185: CLK_32K_REG (0x50000020)

Bit	Mode	Symbol	Description	Reset
2:1	R/W	XTAL32K_RBIAS	Setting for the bias resistor. 00 is maximum, 11 is minimum. Preferred setting will be provided by Dialog	0x2
0	R/W	XTAL32K_ENABLE	Enables the 32kHz XTAL oscillator	0x0

Table 186: CLK_16M_REG (0x50000022)

Bit	Mode	Symbol	Description	Reset
14	R/W	XTAL16_HPASS_FLT_EN	enables high pass filter	0x0
13	R/W	XTAL16_SPIKE_FLT_BYPASS	bypasses spikefilter	0x0
12:10	R/W	XTAL16_AMP_TRIM	sets xtal amplitude, 0 is minimum, 101 is maximum	0x3
7:5	R/W	XTAL16_CUR_SET	start-up current for the 16MHz XTAL oscillator. 000 is minimum, 110 is maximum.	0x0
4:1	R/W	RC16M_TRIM	0000 = lowest frequency 1111 = highest frequency	0x0
0	R/W	RC16M_ENABLE	Enables the 16MHz RC oscillator	0x0

Table 187: CLK_RCX20K_REG (0x50000024)

Bit	Mode	Symbol	Description	Reset
11	R/W	RCX20K_ENABLE	Enable the RCX32 oscillator	0
10	R/W	RCX20K_LOWF	Extra low frequency	0
9:8	R/W	RCX20K_BIAS	Bias control	1
7:4	R/W	RCX20K_NTC	Temperature control	7
3:0	R/W	RCX20K_TRIM	0000 = lowest frequency 0111 = default 1111 = highest frequency	8

Table 188: BANDGAP_REG (0x50000028)

Bit	Mode	Symbol	Description	Reset
14	R/W	BYPASS_COLD_BOOT_DISABLE	0x1 -> Switch to LDO_SUPPLY_USB on vbus_available & vbus_high & wokenup (SET to 0x1 after boot) 0x0 -> Switch to LDO_SUPPLY_USB on vbus_available	0x0
13:10	R/W	LDO_SLEEP_TRIM	0x4 --> 1120 mV 0x5 --> 1089 mV 0x6 --> 1058 mV 0x7 --> 1030 mV 0x0 --> 1037 mV 0x1 --> 1005 mV 0x2 --> 978 mV 0x3 --> 946 mV 0x8 --> 952 mV 0x9 --> 918 mV 0xA --> 889 mV 0xB --> 861 mV 0xC --> 862 mV 0xD --> 828 mV 0xE --> 798 mV 0xF --> 770 mV These values are from simulation and vary over corners	0x0

Table 188: BANDGAP_REG (0x50000028)

Bit	Mode	Symbol	Description	Reset
9:5	R/W	BGR_ITRIM	Current trimming for bias	0x0
4:0	R/W	BGR_TRIM	Trim register for bandgap	0x0

Table 189: ANA_STATUS_REG (0x5000002A)

Bit	Mode	Symbol	Description	Reset
15	R	COMP_1V8_PA_HIGH	VDD1V8P > 1.7V	0x0
14	R	COMP_1V8_FLASH_HIGH	VDD1V8 > 1.7V	0x0
13	R	COMP_V33_HIGH	V33 > 1.7V	0x0
12	R	COMP_VBUS_LOW	VBUS > 3.4V	0x0
11	R	COMP_VBUS_HIGH	VBUS > 4V	0x0
10	R	LDO_1V8_FLASH_OK	ldo_vdd1v8 = ok	0x0
9	R	LDO_1V8_PA_OK	ldo_vdd1v8P = ok	0x0
8	R	LDO_CORE_OK	ldo_core = ok	0x0
7	R	COMP_VDD_HIGH	VDD > 1.13V	0x1
6	R	BANDGAP_OK	bandgap = ok	0x0
5	R	LDO_SUPPLY_USB_OK	ldo_supply_usb = ok	0x0
4	R	LDO_SUPPLY_VBAT_OK	ldo_supply_vbat = ok	0x1
3	R	NEWBAT	new battery has been detected	0x0
2	R	VBUS_AVAILABLE	vbus is available (vbus > vbat)	0x0
1	R	COMP_VBAT_OK	vbat > 1.7V	0x0
0	R	LDO_RADIO_OK	ldo_radio = ok	0x0

Table 190: VBUS_IRQ_MASK_REG (0x50000030)

Bit	Mode	Symbol	Description	Reset
1	R/W	VBUS_IRQ_EN_RISE	Setting this bit to '1' enables VBUS_IRQ generation when the VBUS starts to ramp above threshold	0x0
0	R/W	VBUS_IRQ_EN_FALL	Setting this bit to '1' enables VBUS_IRQ generation when the VBUS starts to fall below threshold	0x0

Table 191: VBUS_IRQ_CLEAR_REG (0x50000032)

Bit	Mode	Symbol	Description	Reset
15:0	R/W	VBUS_IRQ_CLEAR	Writing any value to this register will reset the VBUS_IRQ line	0x0

Table 192: BOD_CTRL_REG (0x50000034)

Bit	Mode	Symbol	Description	Reset
10:8	R/W	BOD_VDD_LVL	VDD BOD Level; 0=700mV; 1=700mV; 3=800mV; 7=1.05V	0x7
7:0	-	Reserved	Reserved	0x0

Table 193: BOD_CTRL2_REG (0x50000036)

Bit	Mode	Symbol	Description	Reset
5	R/W	BOD_VBAT_EN	VBAT BOD Enable	0x0
4	R/W	BOD_1V8_FLASH_EN	1V8 Flash BOD Enable	0x0
3	R/W	BOD_1V8_PA_EN	1V8 PA BOD Enable	0x0
2	R/W	BOD_V33_EN	V33 BOD Enable	0x0
1	R/W	BOD_VDD_EN	VDD BOD Enable	0x0
0	R/W	BOD_RESET_EN	Generate a chip reset on BOD event	0x0

Table 194: BOD_STATUS_REG (0x50000038)

Bit	Mode	Symbol	Description	Reset
4	R/W	BOD_VBAT_LOW	Indicates VBAT > VBAT_Trigger	0x0
3	R/W	BOD_V33_LOW	Indicates V33 > V33_Trigger	0x0
2	R/W	BOD_1V8_FLASH_LOW	Indicates V18_Flash > V18_Flash_Trigger	0x0
1	R/W	BOD_1V8_PA_LOW	Indicates V18_PA > V18_PA_Trigger	0x0
0	R/W	BOD_VDD_LOW	Indicates VDD > VDD_Trigger	0x0

Table 195: LDO_CTRL1_REG (0x5000003A)

Bit	Mode	Symbol	Description	Reset
14	R/W	LDO_RADIO_ENABLE	Enables (1) or disables (0) LDO_RADIO (V14) For fast XTAL startup, this bit may be kept to '1' during deep sleep. The LDO is switched off automatically when in deep sleep, and enabled when waking up.	0x0
13:11	R/W	LDO_RADIO_SETVDD	Sets the output voltage of LDO_RADIO 000 = 1.30 V 001 = 1.35 V 010 = 1.40 V 011 = 1.45 V 1XX = 1.50 V	0x0
10:8	R/W	LDO_CORE_SETVDD	Sets the output voltage of LDO_CORE 000 = 1.20 V 001 = 1.15 V 010 = 1.10 V 011 = 1.05 V 1XX = 1.32 V	0x0
7:6	R/W	LDO_SUPPLY_USB_LEVEL	Sets the output voltage of LDO_SUPPLY_USB 00 = 2.40 V 01 = 3.30 V 10 = 3.45 V 11 = 3.60 V	0x1
5:4	R/W	LDO_SUPPLY_VBAT_LEVEL	Sets the output voltage of LDO_SUPPLY_VBAT 00 = 2.40 V 01 = 3.30 V 10 = 3.45 V 11 = 3.60 V	0x1

Table 195: LDO_CTRL1_REG (0x5000003A)

Bit	Mode	Symbol	Description	Reset
3:2	R/W	LDO_VBAT_RET_LEVEL	Sets the output voltage of LDO_VBAT_RET 00 = 2.40 V 01 = 3.30 V 10 = 3.45 V 11 = 3.60 V	0x1
1:0	R/W	LDO_CORE_CURRENT	Sets the current limit of LDO_CORE 00 = Current limiter disabled 01 = 8 mA 10 = 60 mA 11 = 80 mA	0x3

Table 196: LDO_CTRL2_REG (0x5000003C)

Bit	Mode	Symbol	Description	Reset
6	R/W	LDO_1V8_PA_RET_DISABLE	Disables (1) or enables (0) LDO_1V8_PA_RET	0x0
5	R/W	LDO_1V8_FLASH_RET_DISABLE	Disables (1) or enables (0) LDO_1V8_FLASH_RET	0x0
4	R/W	LDO_VBAT_RET_DISABLE	Disables (1) or enables (0) LDO_VBAT_RET	0x0
3	R/W	LDO_1V8_PA_ON	Enables (1) or disables (0) LDO_1V8_PA	0x1
2	R/W	LDO_1V8_FLASH_ON	Enables (1) or disables (0) LDO_1V8_FLASH	0x1
1	R/W	LDO_3V3_ON	Enables (1) or disables (0) LDO_SUPPLY_VBAT and LDO_SUPPLY_USB	0x1
0	R/W	LDO_1V2_ON	Enables (1) or disables (0) LDO_CORE	0x1

Table 197: SLEEP_TIMER_REG (0x5000003E)

Bit	Mode	Symbol	Description	Reset
15:0	R/W	SLEEP_TIMER	Defines the amount of ticks of the sleep clock between enabling the bandgap for re-charging the retention LDOs. This value depends on the load and should be calibrated on a per application basis. If set to 0, no recharging cycle will happen at all. Keep this value to 0 (no recharging) when using the clock-less sleep.	0x0

Table 198: XTALRDY_CTRL_REG (0x50000050)

Bit	Mode	Symbol	Description	Reset
7:0	R/W	XTALRDY_CNT	Number of LP cycles between the crystal is enabled, and the XTALRDY_IRQ is fired. 0x00: no interrupt	0x0

37.7 DCDC REGISTER FILE

Table 199: Register map DCDC

Address	Port	Description
0x50000082	DCDC_CTRL_0_REG	DCDC First Control Register
0x50000084	DCDC_CTRL_1_REG	DCDC Second Control Register
0x50000086	DCDC_CTRL_2_REG	DCDC Third Control Register
0x50000088	DCDC_V14_0_REG	DCDC V14 First Control Register
0x5000008A	DCDC_V14_1_REG	DCDC V14 Second Control Register
0x5000008C	DCDC_V18_0_REG	DCDC V18 First Control Register
0x5000008E	DCDC_V18_1_REG	DCDC V18 Second Control Register
0x50000090	DCDC_VDD_0_REG	DCDC VDD First Control Register
0x50000092	DCDC_VDD_1_REG	DCDC VDD Second Control Register
0x50000094	DCDC_V18P_0_REG	DCDC VPA First Control Register
0x50000096	DCDC_V18P_1_REG	DCDC VPA Second Control Register
0x50000098	DCDC_RET_0_REG	DCDC First Retention Mode Register
0x5000009A	DCDC_RET_1_REG	DCDC Second Retention Mode Register
0x5000009C	DCDC_TRIM_REG	DCDC Comparator Trim Register
0x5000009E	DCDC_TEST_0_REG	DCDC Test Register
0x500000A0	DCDC_TEST_1_REG	DCDC Test Register
0x500000A2	DCDC_STATUS_0_REG	DCDC First Status Register
0x500000A4	DCDC_STATUS_1_REG	DCDC Second Status Register
0x500000A6	DCDC_STATUS_2_REG	DCDC Third Status Register
0x500000A8	DCDC_STATUS_3_REG	DCDC Fourth Status Register
0x500000AA	DCDC_STATUS_4_REG	DCDC Fifth Status Register
0x500000AC	DCDC_TRIM_0_REG	DCDC V14 Comparator Trim Register
0x500000AE	DCDC_TRIM_1_REG	DCDC V18 Comparator Trim Register
0x500000B0	DCDC_TRIM_2_REG	DCDC VDD Comparator Trim Register
0x500000B2	DCDC_TRIM_3_REG	DCDC VPA Comparator Trim Register
0x500000B4	DCDC_IRQ_STATUS_REG	DCDC Interrupt Status Register
0x500000B6	DCDC_IRQ_CLEAR_REG	DCDC Interrupt Clear Register
0x500000B8	DCDC_IRQ_MASK_REG	DCDC Interrupt Clear Register

Table 200: DCDC_CTRL_0_REG (0x50000082)

Bit	Mode	Symbol	Description	Reset
14	R/W	DCDC_FAST_START UP	Set current limit to maximum during initial startup	0x0
13	R/W	DCDC_BROWNOUT _LV_MODE	Switches to low voltage settings when battery voltage drops below 2.5 V	0x1
12:11	R/W	DCDC_IDLE_CLK_D IV	Idle Clock Divider 00 = 2 01 = 4 10 = 8 11 = 16	0x1
10:3	R/W	DCDC_PRIORITY	Charge priority register (4x 2 bit ID) Charge sequence is [1:0] > [3:2] > [5:4] > [7:6] ID[V14] = 00 ID[V18] = 01 ID[VDD] = 10 ID[V18P] = 11	0xE4

Table 200: DCDC_CTRL_0_REG (0x50000082)

Bit	Mode	Symbol	Description	Reset
2	R/W	DCDC_FW_ENABLE	Freewheel switch enable	0x1
1:0	R/W	DCDC_MODE	DCDC converter mode 00 = Disabled 01 = Active 10 = Sleep mode 11 = Disabled	0x0

Table 201: DCDC_CTRL_1_REG (0x50000084)

Bit	Mode	Symbol	Description	Reset
15:11	R/W	DCDC_STARTUP_DELAY	Delay between turning bias on and converter becoming active 0 - 31 us, 1 us step size	0xA
10:5	R/W	DCDC_GLOBAL_MAX_IDLE_TIME	Global maximum idle time The current limit of any output that is idle for this long will be downramped faster than normal 0 - 7875 ns, 125 ns step size	0x20
4:0	R/W	DCDC_TIMEOUT	P and N switch timeout, if switch is closed longer than this a timeout is generated and the FSM is forced to the next state 0 - 1937.5 ns, 62.5 ns step size	0x10

Table 202: DCDC_CTRL_2_REG (0x50000086)

Bit	Mode	Symbol	Description	Reset
15:12	R/W	DCDC_TIMEOUT_IRQ_TRIG	Number of timeout events before timeout interrupt is generated	0x8
11:8	R/W	DCDC_TIMEOUT_IRQ_RES	Number of successive non-timed out charge events required to clear timeout event counter	0x8
7:6	R/W	DCDC_TUNE	Trim current sensing circuitry 00 = +0 % 01 = +4 % 10 = +8 % 11 = +12 %	0x0
5:3	R/W	DCDC_LSSUP_TRIM	Trim low side supply voltage $V = 2\text{ V} + 100\text{ mV} * N$	0x5
2:0	R/W	DCDC_HSGND_TRIM	Trim high side ground $V = V_{\text{BAT}} - (2.2\text{ V} + 200\text{ mV} * N)$	0x5

Table 203: DCDC_V14_0_REG (0x50000088)

Bit	Mode	Symbol	Description	Reset
15	R/W	DCDC_V14_FAST_RAMPING	V14 output fast current ramping (improves response time at the cost of more ripple)	0x1
14:10	R/W	DCDC_V14_VOLTAGE	V14 output voltage $V = 1.2\text{ V} + 25\text{ mV} * N$	0x8
9:5	R/W	DCDC_V14_CUR_LIMIT_MAX_HV	V14 output maximum current limit (high battery voltage mode) $I = 30\text{ mA} * (1 + N)$	0xD
4:0	R/W	DCDC_V14_CUR_LIMIT_MIN	V14 output minimum current limit $I = 30\text{ mA} * (1 + N)$	0x4

Table 204: DCDC_V14_1_REG (0x5000008A)

Bit	Mode	Symbol	Description	Reset
15	R/W	DCDC_V14_ENABL E_HV	V14 output enable (high battery voltage mode) 0 = Disabled 1 = Enabled	0x1
14	R/W	DCDC_V14_ENABL E_LV	V14 output enable (low battery voltage mode) 0 = Disabled 1 = Enabled	0x1
13:10	R/W	DCDC_V14_CUR_LI M_MAX_LV	V14 output maximum current limit low battery voltage mode) $I = 30 \text{ mA} * (1 + N)$	0x6
9:5	R/W	DCDC_V14_IDLE_H YST	V14 output idle time hysteresis 0 - 3875 ns, 125 ns step size IDLE_MAX = IDLE_MIN + IDLE_HYST Maximum idle time before decreasing CUR_LIM	0x4
4:0	R/W	DCDC_V14_IDLE_MI N	V14 output minimum idle time 0 - 3875 ns, 125 ns step size Minimum idle time, CUR_LIM is increased if this limit is not reached	0x10

Table 205: DCDC_V18_0_REG (0x5000008C)

Bit	Mode	Symbol	Description	Reset
15	R/W	DCDC_V18_FAST_R AMPING	V18 output fast current ramping (improves response time at the cost of more ripple)	0x1
14:10	R/W	DCDC_V18_VOLTAG E	V18 output voltage $V = 1.2 \text{ V} + 25 \text{ mV} * N$	0x18
9:5	R/W	DCDC_V18_CUR_LI M_MAX_HV	V18 output maximum current limit (high battery voltage mode) $I = 30 \text{ mA} * (1 + N)$	0x1F
4:0	R/W	DCDC_V18_CUR_LI M_MIN	V18 output minimum current limit $I = 30 \text{ mA} * (1 + N)$	0x4

Table 206: DCDC_V18_1_REG (0x5000008E)

Bit	Mode	Symbol	Description	Reset
15	R/W	DCDC_V18_ENABL E_HV	V18 output enable (high battery voltage mode) 0 = Disabled 1 = Enabled	0x1
14	R/W	DCDC_V18_ENABL E_LV	V18 output enable (low battery voltage mode) 0 = Disabled 1 = Enabled	0x0
13:10	R/W	DCDC_V18_CUR_LI M_MAX_LV	V18 output maximum current limit low battery voltage mode) $I = 30 \text{ mA} * (1 + N)$	0xF
9:5	R/W	DCDC_V18_IDLE_H YST	V18 output idle time hysteresis 0 - 3875 ns, 125 ns step size IDLE_MAX = IDLE_MIN + IDLE_HYST Maximum idle time before decreasing CUR_LIM	0x4
4:0	R/W	DCDC_V18_IDLE_MI N	V18 output minimum idle time 0 - 3875 ns, 125 ns step size Minimum idle time, CUR_LIM is increased if this limit is not reached	0x10

Table 207: DCDC_VDD_0_REG (0x50000090)

Bit	Mode	Symbol	Description	Reset
15	R/W	DCDC_VDD_FAST_RAMPING	VDD output fast current ramping (improves response time at the cost of more ripple)	0x1
14:10	R/W	DCDC_VDD_VOLTAGE	VDD output voltage $V = 0.8\text{ V} + 25\text{ mV} * N$	0x10
9:5	R/W	DCDC_VDD_CUR_LIM_MAX_HV	VDD output maximum current limit (high battery voltage mode) $I = 30\text{ mA} * (1 + N)$	0x18
4:0	R/W	DCDC_VDD_CUR_LIM_MIN	VDD output minimum current limit $I = 30\text{ mA} * (1 + N)$	0x4

Table 208: DCDC_VDD_1_REG (0x50000092)

Bit	Mode	Symbol	Description	Reset
15	R/W	DCDC_VDD_ENABLE_HV	VDD output enable (high battery voltage mode) 0 = Disabled 1 = Enabled	0x1
14	R/W	DCDC_VDD_ENABLE_LV	VDD output enable (low battery voltage mode) 0 = Disabled 1 = Enabled	0x1
13:10	R/W	DCDC_VDD_CUR_LIM_MAX_LV	VDD output maximum current limit low battery voltage mode) $I = 30\text{ mA} * (1 + N)$	0xB
9:5	R/W	DCDC_VDD_IDLE_HYST	VDD output idle time hysteresis 0 - 3875 ns, 125 ns step size $IDLE_MAX = IDLE_MIN + IDLE_HYST$ Maximum idle time before decreasing CUR_LIM	0x4
4:0	R/W	DCDC_VDD_IDLE_MIN	VDD output minimum idle time 0 - 3875 ns, 125 ns step size Minimum idle time, CUR_LIM is increased if this limit is not reached	0x10

Table 209: DCDC_V18P_0_REG (0x50000094)

Bit	Mode	Symbol	Description	Reset
15	R/W	DCDC_V18P_FAST_RAMPING	V18P output fast current ramping (improves response time at the cost of more ripple)	0x1
14:10	R/W	DCDC_V18P_VOLTAGE	V18P output voltage $V = 1.2\text{ V} + 25\text{ mV} * N$	0x18
9:5	R/W	DCDC_V18P_CUR_LIM_MAX_HV	V18P output maximum current limit (high battery voltage mode) $I = 30\text{ mA} * (1 + N)$	0x1F
4:0	R/W	DCDC_V18P_CUR_LIM_MIN	V18P output minimum current limit $I = 30\text{ mA} * (1 + N)$	0x4

Table 210: DCDC_V18P_1_REG (0x50000096)

Bit	Mode	Symbol	Description	Reset
15	R/W	DCDC_V18P_ENABLE_HV	V18P output enable (high battery voltage mode) 0 = Disabled 1 = Enabled	0x1

Table 210: DCDC_V18P_1_REG (0x50000096)

Bit	Mode	Symbol	Description	Reset
14	R/W	DCDC_V18P_ENAB LE_LV	V18P output enable (low battery voltage mode) 0 = Disabled 1 = Enabled	0x0
13:10	R/W	DCDC_V18P_CUR_ LIM_MAX_LV	V18P output maximum current limit low battery voltage mode) $I = 30 \text{ mA} * (1 + N)$	0xF
9:5	R/W	DCDC_V18P_IDLE_ HYST	V18P output idle time hysteresis 0 - 3875 ns, 125 ns step size IDLE_MAX = IDLE_MIN + IDLE_HYST Maximum idle time before decreasing CUR_LIM	0x4
4:0	R/W	DCDC_V18P_IDLE_ MIN	V18P output minimum idle time 0 - 3875 ns, 125 ns step size Minimum idle time, CUR_LIM is increased if this limit is not reached	0x10

Table 211: DCDC_RET_0_REG (0x50000098)

Bit	Mode	Symbol	Description	Reset
15:13	R/W	DCDC_V18P_RET_ CYCLES	Charge cycles for V18P output in sleep mode Cycles = $1 + 2 * N$	0x5
12:8	R/W	DCDC_V18P_CUR_ LIM_RET	V18P output sleep mode current limit $I = 30 \text{ mA} * (1 + N)$	0xA
7:5	R/W	DCDC_VDD_RET_C YCLES	Charge cycles for VDD output in sleep mode Cycles = $1 + 2 * N$	0x5
4:0	R/W	DCDC_VDD_CUR_LI M_RET	VDD output sleep mode current limit $I = 30 \text{ mA} * (1 + N)$	0x6

Table 212: DCDC_RET_1_REG (0x5000009A)

Bit	Mode	Symbol	Description	Reset
15:13	R/W	DCDC_V18_RET_C YCLES	Charge cycles for V18 output in sleep mode Cycles = $1 + 2 * N$	0x5
12:8	R/W	DCDC_V18_CUR_LI M_RET	V18 output sleep mode current limit $I = 30 \text{ mA} * (1 + N)$	0xA
7:5	R/W	DCDC_V14_RET_C YCLES	Charge cycles for V14 output in sleep mode Cycles = $1 + 2 * N$	0x2
4:0	R/W	DCDC_V14_CUR_LI M_RET	V14 output sleep mode current limit $I = 30 \text{ mA} * (1 + N)$	0x6

Table 213: DCDC_TRIM_REG (0x5000009C)

Bit	Mode	Symbol	Description	Reset
13	R/W	DCDC_P_COMP_M AN_TRIM	Trim mode for P side comparator 0 = Automatic 1 = Manual	0x0
12:7	R/W	DCDC_P_COMP_TR IM	Manual trim value for P side comparator Signed magnitude representation 011111 = +47 mV 000000 = 100000 = +16 mV 111111 = -15 mV	0x0

Table 213: DCDC_TRIM_REG (0x5000009C)

Bit	Mode	Symbol	Description	Reset
6	R/W	DCDC_N_COMP_M AN_TRIM	Trim mode for N side comparator 0 = Automatic 1 = Manual	0x0
5:0	R/W	DCDC_N_COMP_TR IM	Manual trim value for N side comparator Signed magnitude representation 011111 = +13 mV 000000 = 100000 = -22 mV 111111 = -56 mV	0x0

Table 214: DCDC_TEST_0_REG (0x5000009E)

Bit	Mode	Symbol	Description	Reset
15	R/W	DCDC_FORCE_CO MP_CLK	Disables automatic comparator clock, clock lines values based on DCDC_COMP_CLK	0x0
14	R/W	DCDC_FORCE_CUR RENT	Force output current setting	0x0
13:11	R/W	DCDC_OUTPUT_M ONITOR	Output monitor switch (connect to ADC) 000 = None 001 = V14 010 = V18 011 = VDD 100 = VPA 101 = None 110 = None 111 = None	0x0
10:8	R/W	DCDC_ANA_TEST	Analog test bus 000 = None 001 = High side ground 010 = Low side supply 011 = 1.2 V buffer output 100 = None 101 = None 110 = None 111 = None	0x0
7	R/W	DCDC_FORCE_IDL E	Force idle mode	0x0
6	R/W	DCDC_FORCE_V18 P	Force V18P switch on	0x0
5	R/W	DCDC_FORCE_VDD	Force VDD switch on	0x0
4	R/W	DCDC_FORCE_V18	Force V18 switch on	0x0
3	R/W	DCDC_FORCE_V14	Force V14 switch on	0x0
2	R/W	DCDC_FORCE_FW	Force FW switch on	0x0
1	R/W	DCDC_FORCE_NS W	Force N switch on	0x0
0	R/W	DCDC_FORCE_PS W	Force P switch on	0x0

Table 215: DCDC_TEST_1_REG (0x500000A0)

Bit	Mode	Symbol	Description	Reset
12:9	R/W	DCDC_COMP_CLK	Forced clock values for [COMP_VPA, COMP_VDD, COMP_V18, COMP_V14] (requires DCDC_FORCE_COMP_CLK = 1)	0x0

Table 215: DCDC_TEST_1_REG (0x500000A0)

Bit	Mode	Symbol	Description	Reset
8:4	R/W	DCDC_TEST_CURR ENT	Current limit setting when current limit is forced	0x0
3:0	R/W	DCDC_TEST_REG	Determines which register appears on the testbus 0x0 = DCDC_NONE 0x1 = DCDC_STATUS_0 0x2 = DCDC_STATUS_1 0x3 = DCDC_STATUS_2 0x4 = DCDC_STATUS_3 0x5 = DCDC_STATUS_4 0x6 = DCDC_TRIM_0 0x7 = DCDC_TRIM_1 0x8 = DCDC_TRIM_2 0x9 = DCDC_TRIM_3 0xA-0xF = DCDC_NONE	0x0

Table 216: DCDC_STATUS_0_REG (0x500000A2)

Bit	Mode	Symbol	Description	Reset
11:9	R	DCDC_CHARGE_RE G_3	Charge register position 3	0x0
8:6	R	DCDC_CHARGE_RE G_2	Charge register position 2	0x0
5:3	R	DCDC_CHARGE_RE G_1	Charge register position 1	0x0
2:0	R	DCDC_CHARGE_RE G_0	Charge register position 0	0x0

Table 217: DCDC_STATUS_1_REG (0x500000A4)

Bit	Mode	Symbol	Description	Reset
11	R	DCDC_V18P_AVAIL ABLE	Indicates whether V18P is available Requires that converter is enabled, output is enabled and V_OK and V_NOK have both occurred	0x0
10	R	DCDC_VDD_AVAILA BLE	Indicates whether VDD is available Requires that converter is enabled, output is enabled and V_OK and V_NOK have both occurred	0x0
9	R	DCDC_V18_AVAILA BLE	Indicates whether V18 is available Requires that converter is enabled, output is enabled and V_OK and V_NOK have both occurred	0x0
8	R	DCDC_V14_AVAILA BLE	Indicates whether V14 is available Requires that converter is enabled, output is enabled and V_OK and V_NOK have both occurred	0x0
7	R	DCDC_V18P_OK	OK output of V18P comparator	0x0
6	R	DCDC_VDD_OK	OK output of VDD comparator	0x0
5	R	DCDC_V18_OK	OK output of V18 comparator	0x0
4	R	DCDC_V14_OK	OK output of V14 comparator	0x0
3	R	DCDC_V18P_NOK	NOK output of V18P comparator	0x0
2	R	DCDC_VDD_NOK	NOK output of VDD comparator	0x0
1	R	DCDC_V18_NOK	NOK output of V18 comparator	0x0
0	R	DCDC_V14_NOK	NOK output of V14 comparator	0x0

Table 218: DCDC_STATUS_2_REG (0x500000A6)

Bit	Mode	Symbol	Description	Reset
11	R	DCDC_V18P_SW_S TATE	DCDC state machine V18P output	0x0
10	R	DCDC_VDD_SW_ST ATE	DCDC state machine VDD output	0x0
9	R	DCDC_V18_SW_ST ATE	DCDC state machine V18 output	0x0
8	R	DCDC_V14_SW_ST ATE	DCDC state machine V14 output	0x0
7	R	DCDC_NSW_STATE	DCDC state machine NSW output	0x0
6	R	DCDC_PSW_STATE	DCDC state machine PSW output	0x0
5	R	DCDC_P_COMP_P	DCDC P side dynamic comparator P output	0x0
4	R	DCDC_P_COMP_N	DCDC P side dynamic comparator N output	0x0
3	R	DCDC_N_COMP_P	DCDC N side dynamic comparator P output	0x0
2	R	DCDC_N_COMP_N	DCDC N side dynamic comparator N output	0x0
1	R	DCDC_P_COMP	DCDC P side continuous time comparator output	0x0
0	R	DCDC_N_COMP	DCDC N side continuous time comparator output	0x0

Table 219: DCDC_STATUS_3_REG (0x500000A8)

Bit	Mode	Symbol	Description	Reset
10	R	DCDC_LV_MODE	Indicates if the converter is in low battery voltage mode	0x0
9:5	R	DCDC_I_LIM_V18P	Actual V18P current limit	0x4
4:0	R	DCDC_I_LIM_VDD	Actual VDD current limit	0x4

Table 220: DCDC_STATUS_4_REG (0x500000AA)

Bit	Mode	Symbol	Description	Reset
9:5	R	DCDC_I_LIM_V18	Actual V18 current limit	0x4
4:0	R	DCDC_I_LIM_V14	Actual V14 current limit	0x4

Table 221: DCDC_TRIM_0_REG (0x500000AC)

Bit	Mode	Symbol	Description	Reset
11:6	R	DCDC_V14_TRIM_P	P comparator trim value when V14 is active Signed magnitude representation 011111 = +47 mV 000000 = 100000 = +16 mV 111111 = -15 mV	0x0
5:0	R	DCDC_V14_TRIM_N	N comparator trim value when V14 is active Signed magnitude representation 011111 = +13 mV 000000 = 100000 = -22 mV 111111 = -56 mV	0x0

Table 222: DCDC_TRIM_1_REG (0x500000AE)

Bit	Mode	Symbol	Description	Reset
11:6	R	DCDC_V18_TRIM_P	P comparator trim value when V18 is active Signed magnitude representation 011111 = +47 mV 000000 = 100000 = +16 mV 111111 = -15 mV	0x0
5:0	R	DCDC_V18_TRIM_N	N comparator trim value when V18 is active Signed magnitude representation 011111 = +13 mV 000000 = 100000 = -22 mV 111111 = -56 mV	0x0

Table 223: DCDC_TRIM_2_REG (0x500000B0)

Bit	Mode	Symbol	Description	Reset
11:6	R	DCDC_VDD_TRIM_P	P comparator trim value when VDD is active Signed magnitude representation 011111 = +47 mV 000000 = 100000 = +16 mV 111111 = -15 mV	0x0
5:0	R	DCDC_VDD_TRIM_N	N comparator trim value when VDD is active Signed magnitude representation 011111 = +13 mV 000000 = 100000 = -22 mV 111111 = -56 mV	0x0

Table 224: DCDC_TRIM_3_REG (0x500000B2)

Bit	Mode	Symbol	Description	Reset
11:6	R	DCDC_V18P_TRIM_P	P comparator trim value when V18P is active Signed magnitude representation 011111 = +47 mV 000000 = 100000 = +16 mV 111111 = -15 mV	0x0
5:0	R	DCDC_V18P_TRIM_N	N comparator trim value when V18P is active Signed magnitude representation 011111 = +13 mV 000000 = 100000 = -22 mV 111111 = -56 mV	0x0

Table 225: DCDC_IRQ_STATUS_REG (0x500000B4)

Bit	Mode	Symbol	Description	Reset
4	R	DCDC_BROWN_OUT_IRQ_STATUS	Brown out detector triggered (battery voltage below 2.5 V)	0x0
3	R	DCDC_V18P_TIMEOUT_IRQ_STATUS	Timeout occurred on V18P output	0x0
2	R	DCDC_VDD_TIMEOUT_IRQ_STATUS	Timeout occurred on VDD output	0x0
1	R	DCDC_V18_TIMEOUT_IRQ_STATUS	Timeout occurred on V18 output	0x0
0	R	DCDC_V14_TIMEOUT_IRQ_STATUS	Timeout occurred on V14 output	0x0

Table 226: DCDC_IRQ_CLEAR_REG (0x500000B6)

Bit	Mode	Symbol	Description	Reset
4	R0/W	DCDC_BROWN_OUT_IRQ_CLEAR	Clear brown out interrupt	0x0
3	R0/W	DCDC_V18P_TIMEOUT_UT_IRQ_CLEAR	Clear V18P timeout interrupt	0x0
2	R0/W	DCDC_VDD_TIMEOUT_UT_IRQ_CLEAR	Clear VDD timeout interrupt	0x0
1	R0/W	DCDC_V18_TIMEOUT_UT_IRQ_CLEAR	Clear V18 timeout interrupt	0x0
0	R0/W	DCDC_V14_TIMEOUT_UT_IRQ_CLEAR	Clear V14 timeout interrupt	0x0

Table 227: DCDC_IRQ_MASK_REG (0x500000B8)

Bit	Mode	Symbol	Description	Reset
4	R/W	DCDC_BROWN_OUT_IRQ_MASK	Mask brown out interrupt	0x0
3	R/W	DCDC_V18P_TIMEOUT_UT_IRQ_MASK	Mask V18P timeout interrupt	0x0
2	R/W	DCDC_VDD_TIMEOUT_UT_IRQ_MASK	Mask VDD timeout interrupt	0x0
1	R/W	DCDC_V18_TIMEOUT_UT_IRQ_MASK	Mask V18 timeout interrupt	0x0
0	R/W	DCDC_V14_TIMEOUT_UT_IRQ_MASK	Mask V14 timeout interrupt	0x0

37.8 WAKEUP REGISTER FILE

Table 228: Register map WakeUp

Address	Port	Description
0x50000100	WKUP_CTRL_REG	Control register for the wakeup counter
0x50000102	WKUP_COMPARE_REG	Number of events before wakeup interrupt
0x50000104	WKUP_RESET_IRQ_REG	Reset wakeup interrupt
0x50000106	WKUP_COUNTER_REG	Actual number of events of the wakeup counter
0x50000108	WKUP_RESET_CNTR_REG	Reset the event counter
0x5000010A	WKUP_SELECT_P0_REG	select which inputs from P0 port can trigger wkup counter
0x5000010C	WKUP_SELECT_P1_REG	select which inputs from P1 port can trigger wkup counter
0x5000010E	WKUP_SELECT_P2_REG	select which inputs from P2 port can trigger wkup counter
0x50000110	WKUP_SELECT_P3_REG	select which inputs from P3 port can trigger wkup counter
0x50000112	WKUP_SELECT_P4_REG	select which inputs from P3 port can trigger wkup counter
0x50000114	WKUP_POL_P0_REG	select the sesitivity polarity for each P0 input
0x50000116	WKUP_POL_P1_REG	select the sesitivity polarity for each P1 input
0x50000118	WKUP_POL_P2_REG	select the sesitivity polarity for each P2 input
0x5000011A	WKUP_POL_P3_REG	select the sesitivity polarity for each P3 input
0x5000011C	WKUP_POL_P4_REG	select the sesitivity polarity for each P3 input

Table 229: WKUP_CTRL_REG (0x50000100)

Bit	Mode	Symbol	Description	Reset
15:8	-	-	Reserved	0x0
7	R/W	WKUP_ENABLE_IRQ	0: no interrupt will be enabled 1: if the event counter reaches the value set by WKUP_COMPARE_REG an IRQ will be generated	0x0
6	R/W	WKUP_SFT_KEYHIT	0 = no effect 1 = emulate key hit. The event counter will increment by 1 (after debouncing if enabled). First make this bit 0 before any new key hit can be sensed.	0x0
5:0	R/W	WKUP_DEB_VALUE	Keyboard debounce time. If set to 0, no debouncing will be done. Debounce time: $N \cdot 1 \text{ ms}$. $N = 1..63$ Keyboard Debounce Time	0x0

Table 230: WKUP_COMPARE_REG (0x50000102)

Bit	Mode	Symbol	Description	Reset
15:8	-	-	Reserved	0x0
7:0	R/W	COMPARE	The number of events that have to be counted before the wakeup interrupt will be given	0x0

Table 231: WKUP_RESET_IRQ_REG (0x50000104)

Bit	Mode	Symbol	Description	Reset
15:0	W	WKUP_IRQ_RST	writing any value to this register will reset the interrupt. reading always returns 0.	0x0

Table 232: WKUP_COUNTER_REG (0x50000106)

Bit	Mode	Symbol	Description	Reset
15:8	-	-	Reserved	0x0
7:0	R	EVENT_VALUE	This value represents the number of events that have been counted so far. It will be reset by resetting the interrupt.	0x0

Table 233: WKUP_RESET_CNTR_REG (0x50000108)

Bit	Mode	Symbol	Description	Reset
15:0	W	WKUP_CNTR_RST	writing any value to this register will reset the event counter	0x0

Table 234: WKUP_SELECT_P0_REG (0x5000010A)

Bit	Mode	Symbol	Description	Reset
7:0	R/W	WKUP_SELECT_P0	0: input P0x is not enabled for wakeup event counter 1: input P0x is enabled for wakeup event counter	0x0

Table 235: WKUP_SELECT_P1_REG (0x5000010C)

Bit	Mode	Symbol	Description	Reset
7:0	R/W	WKUP_SELECT_P1	0: input P1x is not enabled for wakeup event counter 1: input P1x is enabled for wakeup event counter	0x0

Table 236: WKUP_SELECT_P2_REG (0x5000010E)

Bit	Mode	Symbol	Description	Reset
4:0	R/W	WKUP_SELECT_P2	0: input P2x is not enabled for wakeup event counter 1: input P2x is enabled for wakeup event counter	0x0

Table 237: WKUP_SELECT_P3_REG (0x50000110)

Bit	Mode	Symbol	Description	Reset
7:0	R/W	WKUP_SELECT_P3	0: input P3x is not enabled for wakeup event counter 1: input P3x is enabled for wakeup event counter	0x0

Table 238: WKUP_SELECT_P4_REG (0x50000112)

Bit	Mode	Symbol	Description	Reset
7:0	R/W	WKUP_SELECT_P4	0: input P4x is not enabled for wakeup event counter 1: input P4x is enabled for wakeup event counter	0x0

Table 239: WKUP_POL_P0_REG (0x50000114)

Bit	Mode	Symbol	Description	Reset
7:0	R/W	WKUP_POL_P0	0: enabled input P0x will increment the event counter if that input goes high 1: enabled input P0x will increment the event counter if that input goes low	0x0

Table 240: WKUP_POL_P1_REG (0x50000116)

Bit	Mode	Symbol	Description	Reset
7:0	R/W	WKUP_POL_P1	0: enabled input P1x will increment the event counter if that input goes high 1: enabled input P1x will increment the event counter if that input goes low	0x0

Table 241: WKUP_POL_P2_REG (0x50000118)

Bit	Mode	Symbol	Description	Reset
4:0	R/W	WKUP_POL_P2	0: enabled input P2x will increment the event counter if that input goes high 1: enabled input P2x will increment the event counter if that input goes low	0x0

Table 242: WKUP_POL_P3_REG (0x5000011A)

Bit	Mode	Symbol	Description	Reset
7:0	R/W	WKUP_POL_P3	0: enabled input P3x will increment the event counter if that input goes high 1: enabled input P3x will increment the event counter if that input goes low	0x0

Table 243: WKUP_POL_P4_REG (0x5000011C)

Bit	Mode	Symbol	Description	Reset
7:0	R/W	WKUP_POL_P4	0: enabled input P4x will increment the event counter if that input goes high 1: enabled input P4x will increment the event counter if that input goes low	0x0

37.9 TIMER1 REGISTER FILE

Table 244: Register map Timer1

Address	Port	Description
0x50000200	CAPTIM_CTRL_REG	Capture Timer control register
0x50000202	CAPTIM_TIMER_VAL_REG	Capture Timer counter value
0x50000204	CAPTIM_STATUS_REG	Capture Timer status register
0x50000206	CAPTIM_GPIO1_CONF_REG	Capture Timer gpio1 selection
0x50000208	CAPTIM_GPIO2_CONF_REG	Capture Timer gpio2 selection
0x5000020A	CAPTIM_RELOAD_REG	Capture Timer reload value and Delay in shot mode
0x5000020C	CAPTIM_SHOTWIDTH_REG	Capture Timer Shot duration in shot mode
0x5000020E	CAPTIM_PRESCALER_REG	Capture Timer prescaler value
0x50000210	CAPTIM_CAPTURE_GPIO1_REG	Capture Timer value for event on GPIO1
0x50000212	CAPTIM_CAPTURE_GPIO2_REG	Capture Timer value for event on GPIO2
0x50000214	CAPTIM_PRESCALER_VAL_REG	Capture Timer interrupt status register
0x50000216	CAPTIM_PWM_FREQ_REG	Capture Timer pwm frequency register. PWM5 period is defined by the reference clock frequency multiplied by this value.
0x50000218	CAPTIM_PWM_DC_REG	Capture Timer pwm dc register

Table 245: CAPTIM_CTRL_REG (0x50000200)

Bit	Mode	Symbol	Description	Reset
7	R/W	CAPTIM_SYS_CLK_EN	'1' When Capture Timer use the system clock else use the clock 32KHz	0x0
6	R/W	CAPTIM_FREE_RUN_MODE_EN	Only when timer counts up, if it is '1' timer does not zero when reaches to reload value. it is zero only when it has the max value.	0x0
5	R/W	CAPTIM_IRQ_EN	'1' When Capture timer IRQ unmask, '0' masked	0x0
4	R/W	CAPTIM_IN2_EVENT_FALL_EN	'1' When Input1 event type is falling edge, '0' rising edge	0x0
3	R/W	CAPTIM_IN1_EVENT_FALL_EN	'1' When Input2 event type is falling edge, '0' rising edge	0x0
2	R/W	CAPTIM_COUNT_DOWN_EN	'1' when timer counts down, '0' count up	0x0
1	R/W	CAPTIM_ONESHOT_MODE_EN	'1' Capture Timer in OneShot mode, '0' Capture/Timer mode	0x0
0	R/W	CAPTIM_EN	'1' Capture Timer enabled, else disabled	0x0

Table 246: CAPTIM_TIMER_VAL_REG (0x50000202)

Bit	Mode	Symbol	Description	Reset
15:0	R	CAPTIM_TIMER_VALUE	Gives the current timer value	0x0

Table 247: CAPTIM_STATUS_REG (0x50000204)

Bit	Mode	Symbol	Description	Reset
3:2	R	CAPTIM_ONESHOT_PHASE	0 : Wait for event, 1 : Delay phase, 2 : Start Shot, 3 : Shot phase	0x0
1	R	CAPTIM_IN2_STATE	Gives the logic level of the IN1	0x0
0	R	CAPTIM_IN1_STATE	Gives the logic level of the IN2	0x0

Table 248: CAPTIM_GPIO1_CONF_REG (0x50000206)

Bit	Mode	Symbol	Description	Reset
5:0	R/W	CAPTIM_GPIO1_CONF	Select one of the 37 GPIOs as IN1, Valid value 0-37. 1 for P00 .. 37 for P47. When 0 Disable input	0x0

Table 249: CAPTIM_GPIO2_CONF_REG (0x50000208)

Bit	Mode	Symbol	Description	Reset
5:0	R/W	CAPTIM_GPIO2_CONF	Select one of the 37 GPIOs as IN2, Valid value 0-37. 1 for P00 .. 37 for P47. When 0 Disable input	0x0

Table 250: CAPTIM_RELOAD_REG (0x5000020A)

Bit	Mode	Symbol	Description	Reset
15:0	R/W	CAPTIM_RELOAD	Reload or max value in timer mode, Delay phase duration in oneshot mode. Actual delay is the register value plus synchronization time (3 clock cycles)	0x0

Table 251: CAPTIM_SHOTWIDTH_REG (0x5000020C)

Bit	Mode	Symbol	Description	Reset
15:0	R/W	CAPTIM_SHOTWIDTH	Shot phase duration in oneshot mode	0x0

Table 252: CAPTIM_PRESCALER_REG (0x5000020E)

Bit	Mode	Symbol	Description	Reset
15:0	R/W	CAPTIM_PRESCALER	Define the timer count frequency. $\text{Freq} = \text{Freq_clock} / (\text{value} + 1)$	0x0

Table 253: CAPTIM_CAPTURE_GPIO1_REG (0x50000210)

Bit	Mode	Symbol	Description	Reset
15:0	R	CAPTIM_CAPTURE_GPIO1	Gives the Capture time for event on GPIO1	0x0

Table 254: CAPTIM_CAPTURE_GPIO2_REG (0x50000212)

Bit	Mode	Symbol	Description	Reset
15:0	R	CAPTIM_CAPTURE_GPIO2	Gives the Capture time for event on GPIO2	0x0

Table 255: CAPTIM_PRESCALER_VAL_REG (0x50000214)

Bit	Mode	Symbol	Description	Reset
15:0	R	CAPTIM_PRESCALER_VAL	Gives the current prescaler value	0x0

Table 256: CAPTIM_PWM_FREQ_REG (0x50000216)

Bit	Mode	Symbol	Description	Reset
15:0	R/W	CAPTIM_PWM_FREQ	Define the PWM frequency. = prescaler frequency / (value+1)	0x0

Table 257: CAPTIM_PWM_DC_REG (0x50000218)

Bit	Mode	Symbol	Description	Reset
15:0	R/W	CAPTIM_PWM_DC	Define the PWM duty cycle = pwm_dc / (pwm_freq+1)	0x0

37.10 UART REGISTER FILE

Table 258: Register map UART

Address	Port	Description
0x50001000	UART_RBR_THR_DLL_REG	Receive Buffer Register
0x50001004	UART_IER_DLH_REG	Interrupt Enable Register
0x50001008	UART_IIR_FCR_REG	Interrupt Identification Register
0x5000100C	UART_LCR_REG	Line Control Register
0x50001010	UART_MCR_REG	Modem Control Register
0x50001014	UART_LSR_REG	Line Status Register
0x5000101C	UART_SCR_REG	Scratchpad Register
0x5000107C	UART_USR_REG	UART Status register.
0x50001088	UART_SRR_REG	Software Reset Register.
0x50001090	UART_SBCR_REG	Shadow Break Control Register
0x500010A8	UART_DMA_SA_REG	DMA Software Acknowledge
0x500010C0	UART_DLF_REG	Divisor Latch Fraction Register
0x500010F4	UART_CPR_REG	Component Parameter Register
0x500010F8	UART_UCV_REG	Component Version
0x500010FC	UART_CTR_REG	Component Type Register
0x50001100	UART2_RBR_THR_DLL_REG	Receive Buffer Register
0x50001104	UART2_IER_DLH_REG	Interrupt Enable Register
0x50001108	UART2_IIR_FCR_REG	Interrupt Identification Register/FIFO Control Register
0x5000110C	UART2_LCR_REG	Line Control Register
0x50001110	UART2_MCR_REG	Modem Control Register
0x50001114	UART2_LSR_REG	Line Status Register
0x50001118	UART2_MSR_REG	Modem Status Register
0x5000111C	UART2_SCR_REG	Scratchpad Register
0x50001130	UART2_SRBR_STHR0_REG	Shadow Receive/Transmit Buffer Register
0x50001134	UART2_SRBR_STHR1_REG	Shadow Receive/Transmit Buffer Register
0x50001138	UART2_SRBR_STHR2_REG	Shadow Receive/Transmit Buffer Register
0x5000113C	UART2_SRBR_STHR3_REG	Shadow Receive/Transmit Buffer Register
0x50001140	UART2_SRBR_STHR4_REG	Shadow Receive/Transmit Buffer Register
0x50001144	UART2_SRBR_STHR5_REG	Shadow Receive/Transmit Buffer Register
0x50001148	UART2_SRBR_STHR6_REG	Shadow Receive/Transmit Buffer Register
0x5000114C	UART2_SRBR_STHR7_REG	Shadow Receive/Transmit Buffer Register
0x50001150	UART2_SRBR_STHR8_REG	Shadow Receive/Transmit Buffer Register
0x50001154	UART2_SRBR_STHR9_REG	Shadow Receive/Transmit Buffer Register
0x50001158	UART2_SRBR_STHR10_REG	Shadow Receive/Transmit Buffer Register
0x5000115C	UART2_SRBR_STHR11_REG	Shadow Receive/Transmit Buffer Register
0x50001160	UART2_SRBR_STHR12_REG	Shadow Receive/Transmit Buffer Register
0x50001164	UART2_SRBR_STHR13_REG	Shadow Receive/Transmit Buffer Register
0x50001168	UART2_SRBR_STHR14_REG	Shadow Receive/Transmit Buffer Register
0x5000116C	UART2_SRBR_STHR15_REG	Shadow Receive/Transmit Buffer Register
0x50001170	UART2_FAR_REG	FIFO Access Register
0x5000117C	UART2_USR_REG	UART Status register.
0x50001180	UART2_TFL_REG	Transmit FIFO Level
0x50001184	UART2_RFL_REG	Receive FIFO Level.

Table 258: Register map UART

Address	Port	Description
0x50001188	UART2_SRR_REG	Software Reset Register.
0x5000118C	UART2_SRTS_REG	Shadow Request to Send
0x50001190	UART2_SBCR_REG	Shadow Break Control Register
0x50001194	UART2_SDMAM_REG	Shadow DMA Mode
0x50001198	UART2_SFE_REG	Shadow FIFO Enable
0x5000119C	UART2_SRT_REG	Shadow RCVR Trigger
0x500011A0	UART2_STET_REG	Shadow TX Empty Trigger
0x500011A4	UART2_HTX_REG	Halt TX
0x500011A8	UART2_DMASA_REG	DMA Software Acknowledge
0x500011C0	UART2_DLF_REG	Divisor Latch Fraction Register
0x500011F4	UART2_CPR_REG	Component Parameter Register
0x500011F8	UART2_UCV_REG	Component Version
0x500011FC	UART2_CTR_REG	Component Type Register

Table 259: UART_RBR_THR_DLL_REG (0x50001000)

Bit	Mode	Symbol	Description	Reset
15:8	-	-	Reserved	0x0

Table 259: UART_RBR_THR_DLL_REG (0x50001000)

Bit	Mode	Symbol	Description	Reset
7:0	R/W	RBR_THR_DLL	<p>Receive Buffer Register: (RBR). This register contains the data byte received on the serial input port (sin) in UART mode or the serial infrared input (sir_in) in infrared mode. The data in this register is valid only if the Data Ready (DR) bit in the Line status Register (LSR) is set. The data in the RBR must be read before the next data arrives, otherwise it will be overwritten, resulting in an overrun error.</p> <p>Transmit Holding Register: (THR) This register contains data to be transmitted on the serial output port (sout) in UART mode or the serial infrared output (sir_out_n) in infrared mode. Data should only be written to the THR when the THR Empty (THRE) bit (LSR[5]) is set. Writing a single character to the THR clears the THRE. Any additional writes to the THR before the THRE is set again causes the THR data to be overwritten.</p> <p>Divisor Latch (Low): (DLL) This register makes up the lower 8-bits of a 16-bit, read/write, Divisor Latch register that contains the baud rate divisor for the UART. This register may only be accessed when the DLAB bit (LCR[7]) is set. The output baud rate is equal to the serial clock (sclk) frequency divided by sixteen times the value of the baud rate divisor, as follows: $\text{baud rate} = (\text{serial clock freq}) / (16 * \text{divisor})$ Note that with the Divisor Latch Registers (DLL and DLH) set to zero, the baud clock is disabled and no serial communications will occur. Also, once the DLL is set, at least 8 clock cycles of the slowest DW_apb_uart clock should be allowed to pass before transmitting or receiving data.</p> <p>Divisor Latch (Low): (DLH) (Note: This register is placed in UART_IER_DLH_REG with offset 0x4) Upper 8-bits of a 16-bit, read/write, Divisor Latch register that contains the baud rate divisor for the UART. This register may be accessed only when the DLAB bit (LCR[7]) is set. The output baud rate is equal to the serial clock frequency divided by sixteen times the value of the baud rate divisor, as follows: $\text{baud rate} = (\text{serial clock freq}) / (16 * \text{divisor}).$ Note that with the Divisor Latch Registers (DLL and DLH) set to zero, the baud clock is disabled and no serial communications occur. Also, once the DLH is set, at least 8 clock cycles of the slowest DW_apb_uart clock should be allowed to pass before transmitting or receiving data.</p>	0x0

Table 260: UART_IER_DLH_REG (0x50001004)

Bit	Mode	Symbol	Description	Reset
15:8	-	-	Reserved	0x0
7	R/W	PTIME_DLH7	Interrupt Enable Register: PTIME, Programmable THRE Interrupt Mode Enable. This is used to enable/disable the generation of THRE Interrupt. 0 = disabled 1 = enabled Divisor Latch (High): Bit[7] of the 8 bit DLH register.	0x0
6:4	-	-	Reserved	0x0
3	-	-	Reserved	0x0

Table 260: UART_IER_DLH_REG (0x50001004)

Bit	Mode	Symbol	Description	Reset
2	R/W	ELSI_DHL2	Interrupt Enable Register: ELSI, Enable Receiver Line Status Interrupt. This is used to enable/disable the generation of Receiver Line Status Interrupt. This is the highest priority interrupt. 0 = disabled 1 = enabled Divisor Latch (High): Bit[2] of the 8 bit DLH register.	0x0
1	R/W	ETBEI_DLH1	Interrupt Enable Register: ETBEI, Enable Transmit Holding Register Empty Interrupt. This is used to enable/disable the generation of Transmitter Holding Register Empty Interrupt. This is the third highest priority interrupt. 0 = disabled 1 = enabled Divisor Latch (High): Bit[1] of the 8 bit DLH register.	0x0
0	R/W	ERBFI_DLH0	Interrupt Enable Register: ERBFI, Enable Received Data Available Interrupt. This is used to enable/disable the generation of Received Data Available Interrupt. These are the second highest priority interrupts. 0 = disabled 1 = enabled Divisor Latch (High): Bit[0] of the 8 bit DLH register.	0x0

Table 261: UART_IIR_FCR_REG (0x50001008)

Bit	Mode	Symbol	Description	Reset
15:0	R	IIR_FCR	Interrupt Identification Register: Bits[7:6], returns 00. Bits[3:0], Interrupt ID (or IID): This indicates the highest priority pending interrupt which can be one of the following types: 0001 = no interrupt pending. 0010 = THR empty. 0100 = received data available. 0110 = receiver line status. 0111 = busy detect. 1100 = character timeout.	0x0

Table 262: UART_LCR_REG (0x5000100C)

Bit	Mode	Symbol	Description	Reset
15:8	-	-	Reserved	0x0
7	R/W	UART_DLAB	Divisor Latch Access Bit. This bit is used to enable reading and writing of the Divisor Latch register (DLL and DLH) to set the baud rate of the UART. This bit must be cleared after initial baud rate setup in order to access other registers.	0x0
6	R/W	UART_BC	Break Control Bit. This is used to cause a break condition to be transmitted to the receiving device. If set to one the serial output is forced to the spacing (logic 0) state. When not in Loopback Mode, as determined by MCR[4], the serial output is forced low until the Break bit is cleared. If active (MCR[6] set to one) the sir_out_n line is continuously pulsed. When in Loopback Mode, the break condition is internally looped back to the receiver and the sir_out_n line is forced low.	0x0
5	-	-	Reserved	0x0
4	R/W	UART_EPS	Even Parity Select. Writeable only when UART is not busy (USR[0] is zero). This is used to select between even and odd parity, when parity is enabled (PEN set to one). If set to one, an even number of logic 1s is transmitted or checked. If set to zero, an odd number of logic 1s is transmitted or checked.	0x0

Table 262: UART_LCR_REG (0x5000100C)

Bit	Mode	Symbol	Description	Reset
3	R/W	UART_PEN	Parity Enable. Writeable only when UART is not busy (USR[0] is zero). This bit is used to enable and disable parity generation and detection in transmitted and received serial character respectively. 0 = parity disabled 1 = parity enabled	0x0
2	R/W	UART_STOP	Number of stop bits. This is used to select the number of stop bits per character that the peripheral transmits and receives. If set to zero, one stop bit is transmitted in the serial data. If set to one and the data bits are set to 5 (LCR[1:0] set to zero) one and a half stop bits is transmitted. Otherwise, two stop bits are transmitted. Note that regardless of the number of stop bits selected, the receiver checks only the first stop bit. 0 = 1 stop bit 1 = 1.5 stop bits when DLS (LCR[1:0]) is zero, else 2 stop bit	0x0
1:0	R/W	UART_DLS	Data Length Select. This is used to select the number of data bits per character that the peripheral transmits and receives. The number of bit that may be selected areas follows: 00 = 5 bits 01 = 6 bits 10 = 7 bits 11 = 8 bits	0x0

Table 263: UART_MCR_REG (0x50001010)

Bit	Mode	Symbol	Description	Reset
15:7	-	-	Reserved	0x0
6	R/W	UART_SIRE	SIR Mode Enable. This is used to enable/disable the IrDA SIR Mode features as described in "IrDA 1.0 SIR Protocol". 0 = IrDA SIR Mode disabled 1 = IrDA SIR Mode enabled	0x0
5	-	-	Reserved	0x0
4	R/W	UART_LB	LoopBack Bit. This is used to put the UART into a diagnostic mode for test purposes. If operating in UART mode (SIR_MODE not active, MCR[6] set to zero), data on the sout line is held high, while serial data output is looped back to the sin line, internally. In this mode all the interrupts are fully functional. Also, in loopback mode, the modem control inputs (dsr_n, cts_n, ri_n, dcd_n) are disconnected and the modem control outputs (dtr_n, rts_n, out1_n, out2_n) are looped back to the inputs, internally. If operating in infrared mode (SIR_MODE active, MCR[6] set to one), data on the sir_out_n line is held low, while serial data output is inverted and looped back to the sir_in line.	0x0

Table 263: UART_MCR_REG (0x50001010)

Bit	Mode	Symbol	Description	Reset
3	R/W	UART_OUT2	<p>OUT2.</p> <p>This is used to directly control the user-designated Output2 (out2_n) output. The value written to this location is inverted and driven out on out2_n, that is:</p> <p>0 = out2_n de-asserted (logic 1)</p> <p>1 = out2_n asserted (logic 0)</p> <p>Note that in Loopback mode (MCR[4] set to one), the out2_n output is held inactive high while the value of this location is internally looped back to an input.</p>	0x0
2	R/W	UART_OUT1	<p>OUT1.</p> <p>This is used to directly control the user-designated Output1 (out1_n) output. The value written to this location is inverted and driven out on out1_n, that is:</p> <p>0 = out1_n de-asserted (logic 1)</p> <p>1 = out1_n asserted (logic 0)</p> <p>Note that in Loopback mode (MCR[4] set to one), the out1_n output is held inactive high while the value of this location is internally looped back to an input.</p>	0x0
1:0	-	-	Reserved	0x0

Table 264: UART_LSR_REG (0x50001014)

Bit	Mode	Symbol	Description	Reset
15:7	-	-	Reserved	0x0
6	R	UART_TEMT	<p>Transmitter Empty bit.</p> <p>This bit is set whenever the Transmitter Holding Register and the Transmitter Shift Register are both empty.</p>	0x1
5	R	UART_THRE	<p>Transmit Holding Register Empty bit.</p> <p>If THRE mode is disabled (IER[7] set to zero), this bit indicates that the THR.</p> <p>This bit is set whenever data is transferred from the THR to the transmitter shift register and no new data has been written to the THR. This also causes a THRE Interrupt to occur, if the THRE Interrupt is enabled.</p>	0x1
4	R	UART_BI	<p>Break Interrupt bit.</p> <p>This is used to indicate the detection of a break sequence on the serial input data.</p> <p>If in UART mode (SIR_MODE == Disabled), it is set whenever the serial input, sir_in, is held in a logic '0' state for longer than the sum of start time + data bits + parity + stop bits.</p> <p>If in infrared mode (SIR_MODE == Enabled), it is set whenever the serial input, sir_in, is continuously pulsed to logic '0' for longer than the sum of start time + data bits + parity + stop bits. A break condition on serial input causes one and only one character, consisting of all zeros, to be received by the UART.</p> <p>Reading the LSR clears the BI bit. The BI indication occurs immediately and persists until the LSR is read.</p>	0x0

Table 264: UART_LSR_REG (0x50001014)

Bit	Mode	Symbol	Description	Reset
3	R	UART_FE	<p>Framing Error bit.</p> <p>This is used to indicate the occurrence of a framing error in the receiver. A framing error occurs when the receiver does not detect a valid STOP bit in the received data.</p> <p>When a framing error occurs, the UART tries to resynchronize. It does this by assuming that the error was due to the start bit of the next character and then continues receiving the other bit i.e. data, and/or parity and stop. It should be noted that the Framing Error (FE) bit (LSR[3]) is set if a break interrupt has occurred, as indicated by Break Interrupt (BI) bit (LSR[4]).</p> <p>0 = no framing error 1 = framing error</p> <p>Reading the LSR clears the FE bit.</p>	0x0
2	R	UART_PE	<p>Parity Error bit.</p> <p>This is used to indicate the occurrence of a parity error in the receiver if the Parity Enable (PEN) bit (LCR[3]) is set.</p> <p>It should be noted that the Parity Error (PE) bit (LSR[2]) is set if a break interrupt has occurred, as indicated by Break Interrupt (BI) bit (LSR[4]).</p> <p>0 = no parity error 1 = parity error</p> <p>Reading the LSR clears the PE bit.</p>	0x0
1	R	UART_OE	<p>Overrun error bit.</p> <p>This is used to indicate the occurrence of an overrun error. This occurs if a new data character was received before the previous data was read.</p> <p>The OE bit is set when a new character arrives in the receiver before the previous character was read from the RBR. When this happens, the data in the RBR is overwritten.</p> <p>0 = no overrun error 1 = overrun error</p> <p>Reading the LSR clears the OE bit.</p>	0x0
0	R	UART_DR	<p>Data Ready bit.</p> <p>This is used to indicate that the receiver contains at least one character in the RBR.</p> <p>0 = no data ready 1 = data ready</p> <p>This bit is cleared when the RBR is read.</p>	0x0

Table 265: UART_SCR_REG (0x5000101C)

Bit	Mode	Symbol	Description	Reset
15:8	-	-	Reserved	0x0
7:0	R/W	UART_SCRATCH_P AD	This register is for programmers to use as a temporary storage space. It has no defined purpose in the UART Ctrl.	0x0

Table 266: UART_USR_REG (0x5000107C)

Bit	Mode	Symbol	Description	Reset
15:1	-	-	Reserved	0x0

Table 266: UART_USR_REG (0x5000107C)

Bit	Mode	Symbol	Description	Reset
0	R	UART_BUSY	UART Busy. This indicates that a serial transfer is in progress, when cleared indicates that the DW_apb_uart is idle or inactive. 0 - DW_apb_uart is idle or inactive 1 - DW_apb_uart is busy (actively transferring data) Note that it is possible for the UART Busy bit to be cleared even though a new character may have been sent from another device. That is, if the DW_apb_uart has no data in the THR and RBR and there is no transmission in progress and a start bit of a new character has just reached the DW_apb_uart. This is due to the fact that a valid start is not seen until the middle of the bit period and this duration is dependent on the baud divisor that has been programmed. If a second system clock has been implemented (CLOCK_MODE == Enabled) the assertion of this bit will also be delayed by several cycles of the slower clock.	0x0

Table 267: UART_SRR_REG (0x50001088)

Bit	Mode	Symbol	Description	Reset
15:1	-	-	Reserved	0x0
0	W	UART_UR	UART Reset. This asynchronously resets the UART Ctrl and synchronously removes the reset assertion. For a two clock implementation both pclk and sclk domains are reset.	0x0

Table 268: UART_SBCR_REG (0x50001090)

Bit	Mode	Symbol	Description	Reset
15:1	-	-	Reserved	0x0
0	R/W	UART_SHADOW_B REAK_CONTROL	Shadow Break Control Bit. This is a shadow register for the Break bit (LCR[6]), this can be used to remove the burden of having to performing a read modify write on the LCR. This is used to cause a break condition to be transmitted to the receiving device. If set to one the serial output is forced to the spacing (logic 0) state. When not in Loopback Mode, as determined by MCR[4], the sout line is forced low until the Break bit is cleared. If SIR_MODE active (MCR[6] = 1) the sir_out_n line is continuously pulsed. When in Loopback Mode, the break condition is internally looped back to the receiver.	0x0

Table 269: UART_DMA_SA_REG (0x500010A8)

Bit	Mode	Symbol	Description	Reset
0	W	DMA_SA	This register is use to perform DMA software acknowledge if a transfer needs to be terminated due to an error condition. For example, if the DMA disables the channel, then the DW_apb_uart should clear its request. This will cause the TX request, TX single, RX request and RX single signals to de-assert. Note that this bit is 'self-clearing' and it is not necessary to clear this bit.	0x0

Table 270: UART_DLF_REG (0x500010C0)

Bit	Mode	Symbol	Description	Reset
3:0	R/W	UART_DLF	The fractional value is added to integer value set by DLH, DLL. Fractional value is determined by $(\text{Divisor Fraction value}) / (2^{\text{DLF_SIZE}})$.	0x0

Table 271: UART_CPR_REG (0x500010F4)

Bit	Mode	Symbol	Description	Reset
15:0	R	CPR	Component Parameter Register	0x3941

Table 272: UART_UCV_REG (0x500010F8)

Bit	Mode	Symbol	Description	Reset
15:0	R	UCV	Component Version	0x331352A

Table 273: UART_CTR_REG (0x500010FC)

Bit	Mode	Symbol	Description	Reset
15:0	R	CTR	Component Type Register	0x44570110

Table 274: UART2_RBR_THR_DLL_REG (0x50001100)

Bit	Mode	Symbol	Description	Reset
15:8	-	-	Reserved	0x0

Table 274: UART2_RBR_THR_DLL_REG (0x50001100)

Bit	Mode	Symbol	Description	Reset
7:0	R/W	RBR_THR_DLL	<p>Receive Buffer Register: (RBR). This register contains the data byte received on the serial input port (sin) in UART mode or the serial infrared input (sir_in) in infrared mode. The data in this register is valid only if the Data Ready (DR) bit in the Line status Register (LSR) is set. If FIFOs are disabled (FCR[0] set to zero), the data in the RBR must be read before the next data arrives, otherwise it will be overwritten, resulting in an overrun error. If FIFOs are enabled (FCR[0] set to one), this register accesses the head of the receive FIFO. If the receive FIFO is full and this register is not read before the next data character arrives, then the data already in the FIFO will be preserved but any incoming data will be lost. An overrun error will also occur.</p> <p>Transmit Holding Register: (THR) This register contains data to be transmitted on the serial output port (sout) in UART mode or the serial infrared output (sir_out_n) in infrared mode. Data should only be written to the THR when the THR Empty (THRE) bit (LSR[5]) is set. If FIFO's are disabled (FCR[0] set to zero) and THRE is set, writing a single character to the THR clears the THRE. Any additional writes to the THR before the THRE is set again causes the THR data to be overwritten. If FIFO's are enabled (FCR[0] set to one) and THRE is set, x number of characters of data may be written to the THR before the FIFO is full. The number x (default=16) is determined by the value of FIFO Depth that you set during configuration. Any attempt to write data when the FIFO is full results in the write data being lost.</p> <p>Divisor Latch (Low): (DLL) This register makes up the lower 8-bits of a 16-bit, read/write, Divisor Latch register that contains the baud rate divisor for the UART. This register may only be accessed when the DLAB bit (LCR[7]) is set. The output baud rate is equal to the serial clock (sclk) frequency divided by sixteen times the value of the baud rate divisor, as follows: $\text{baud rate} = (\text{serial clock freq}) / (16 * \text{divisor})$ Note that with the Divisor Latch Registers (DLL and DLH) set to zero, the baud clock is disabled and no serial communications will occur. Also, once the DLL is set, at least 8 clock cycles of the slowest DW_apb_uart clock should be allowed to pass before transmitting or receiving data.</p> <p>Divisor Latch (Low): (DLH) (Note: This register is placed in UART_IER_DLH_REG with offset 0x4) Upper 8-bits of a 16-bit, read/write, Divisor Latch register that contains the baud rate divisor for the UART. This register may be accessed only when the DLAB bit (LCR[7]) is set. The output baud rate is equal to the serial clock frequency divided by sixteen times the value of the baud rate divisor, as follows: $\text{baud rate} = (\text{serial clock freq}) / (16 * \text{divisor}).$ Note that with the Divisor Latch Registers (DLL and DLH) set to zero, the baud clock is disabled and no serial communications occur. Also, once the DLH is set, at least 8 clock cycles of the slowest DW_apb_uart clock should be allowed to pass before transmitting or receiving data.</p>	0x0

Table 275: UART2_IER_DLH_REG (0x50001104)

Bit	Mode	Symbol	Description	Reset
15:8	-	-	Reserved	0x0
7	R/W	PTIME_DLH7	Interrupt Enable Register: PTIME, Programmable THRE Interrupt Mode Enable. This is used to enable/disable the generation of THRE Interrupt. 0 = disabled 1 = enabled Divisor Latch (High): Bit[7] of the 8 bit DLH register.	0x0
6:4	-	-	Reserved	0x0
3	-	-	Reserved	0x0
2	R/W	ELSI_DHL2	Interrupt Enable Register: ELSI, Enable Receiver Line Status Interrupt. This is used to enable/disable the generation of Receiver Line Status Interrupt. This is the highest priority interrupt. 0 = disabled 1 = enabled Divisor Latch (High): Bit[2] of the 8 bit DLH register.	0x0
1	R/W	ETBEI_DLH1	Interrupt Enable Register: ETBEI, Enable Transmit Holding Register Empty Interrupt. This is used to enable/disable the generation of Transmitter Holding Register Empty Interrupt. This is the third highest priority interrupt. 0 = disabled 1 = enabled Divisor Latch (High): Bit[1] of the 8 bit DLH register.	0x0
0	R/W	ERBFI_DLH0	Interrupt Enable Register: ERBFI, Enable Received Data Available Interrupt. This is used to enable/disable the generation of Received Data Available Interrupt and the Character Timeout Interrupt (if in FIFO mode and FIFO's enabled). These are the second highest priority interrupts. 0 = disabled 1 = enabled Divisor Latch (High): Bit[0] of the 8 bit DLH register.	0x0

Table 276: UART2_IIR_FCR_REG (0x50001108)

Bit	Mode	Symbol	Description	Reset
15:0	R/W	IIR_FCR	<p>Interrupt Identification Register, reading this register; FIFO Control Register, writing to this register.</p> <p>Interrupt Identification Register: Bits[7:6], FIFO's Enabled (or FIFOSE): This is used to indicate whether the FIFO's are enabled or disabled. 00 = disabled. 11 = enabled. Bits[3:0], Interrupt ID (or IID): This indicates the highest priority pending interrupt which can be one of the following types:0001 = no interrupt pending. 0010 = THR empty. 0100 = received data available. 0110 = receiver line status. 0111 = busy detect. 1100 = character timeout.</p> <p>FIFO Control Register Bits[7:6], RCVR Trigger (or RT):. This is used to select the trigger level in the receiver FIFO at which the Received Data Available Interrupt will be generated. In auto flow control mode it is used to determine when the rts_n signal will be de-asserted. It also determines when the dma_rx_req_n signal will be asserted when in certain modes of operation. The following trigger levels are supported: 00 = 1 character in the FIFO 01 = FIFO 1/4 full 10 = FIFO 1/2 full 11 = FIFO 2 less than full Bits[5:4], TX Empty Trigger (or TET): This is used to select the empty threshold level at which the THRE Interrupts will be generated when the mode is active. It also determines when the dma_tx_req_n signal will be asserted when in certain modes of operation. The following trigger levels are supported: 00 = FIFO empty 01 = 2 characters in the FIFO 10 = FIFO 1/4 full 11 = FIFO 1/2 full Bit[3], DMA Mode (or DMAM): This determines the DMA signalling mode used for the dma_tx_req_n and dma_rx_req_n output signals. 0 = mode 0 1 = mode 1 Bit[2], XMIT FIFO Reset (or XFIFOR): This resets the control portion of the transmit FIFO and treats the FIFO as empty. Note that this bit is 'self-clearing' and it is not necessary to clear this bit. Bit[1], RCVR FIFO Reset (or RFIFOR): This resets the control portion of the receive FIFO and treats the FIFO as empty. Note that this bit is 'self-clearing' and it is not necessary to clear this bit. Bit[0], FIFO Enable (or FIFOE): This enables/disables the transmit (XMIT) and receive (RCVR) FIFO's. Whenever the value of this bit is changed both the XMIT and RCVR controller portion of FIFO's will be reset.</p>	0x0

Table 277: UART2_LCR_REG (0x5000110C)

Bit	Mode	Symbol	Description	Reset
15:8	-	-	Reserved	0x0
7	R/W	UART_DLAB	<p>Divisor Latch Access Bit.</p> <p>This bit is used to enable reading and writing of the Divisor Latch register (DLL and DLH) to set the baud rate of the UART.</p> <p>This bit must be cleared after initial baud rate setup in order to access other registers.</p>	0x0

Table 277: UART2_LCR_REG (0x5000110C)

Bit	Mode	Symbol	Description	Reset
6	R/W	UART_BC	Break Control Bit. This is used to cause a break condition to be transmitted to the receiving device. If set to one the serial output is forced to the spacing (logic 0) state. When not in Loopback Mode, as determined by MCR[4], the serial line is forced low until the Break bit is cleared. If active (MCR[6] set to one) the sir_out_n line is continuously pulsed. When in Loopback Mode, the break condition is internally looped back to the receiver and the sir_out_n line is forced low.	0x0
5	-	-	Reserved	0x0
4	R/W	UART_EPS	Even Parity Select. Writeable only when UART is not busy (USR[0] is zero). This is used to select between even and odd parity, when parity is enabled (PEN set to one). If set to one, an even number of logic 1s is transmitted or checked. If set to zero, an odd number of logic 1s is transmitted or checked.	0x0
3	R/W	UART_PEN	Parity Enable. Writeable only when UART is not busy (USR[0] is zero) This bit is used to enable and disable parity generation and detection in transmitted and received serial character respectively. 0 = parity disabled 1 = parity enabled	0x0
2	R/W	UART_STOP	Number of stop bits. This is used to select the number of stop bits per character that the peripheral transmits and receives. If set to zero, one stop bit is transmitted in the serial data. If set to one and the data bits are set to 5 (LCR[1:0] set to zero) one and a half stop bits is transmitted. Otherwise, two stop bits are transmitted. Note that regardless of the number of stop bits selected, the receiver checks only the first stop bit. 0 = 1 stop bit 1 = 1.5 stop bits when DLS (LCR[1:0]) is zero, else 2 stop bit	0x0
1:0	R/W	UART_DLS	Data Length Select. This is used to select the number of data bits per character that the peripheral transmits and receives. The number of bit that may be selected areas follows: 00 = 5 bits 01 = 6 bits 10 = 7 bits 11 = 8 bits	0x0

Table 278: UART2_MCR_REG (0x50001110)

Bit	Mode	Symbol	Description	Reset
15:7	-	-	Reserved	0x0
6	R/W	UART_SIRE	SIR Mode Enable. This is used to enable/disable the IrDA SIR Mode features as described in "IrDA 1.0 SIR Protocol". 0 = IrDA SIR Mode disabled 1 = IrDA SIR Mode enabled	0x0

Table 278: UART2_MCR_REG (0x50001110)

Bit	Mode	Symbol	Description	Reset
5	R/W	UART_AFCE	Auto Flow Control Enable. Writeable only when AFCE_MODE == Enabled, always readable. When FIFOs are enabled and the Auto Flow Control Enable (AFCE) bit is set, Auto Flow Control features are enabled as described in "Auto Flow Control". 0 = Auto Flow Control Mode disabled 1 = Auto Flow Control Mode enabled	0x0
4	R/W	UART_LB	LoopBack Bit. This is used to put the UART into a diagnostic mode for test purposes. If operating in UART mode (SIR_MODE not active, MCR[6] set to zero), data on the sout line is held high, while serial data output is looped back to the sin line, internally. In this mode all the interrupts are fully functional. Also, in loopback mode, the modem control inputs (dsr_n, cts_n, ri_n, dcd_n) are disconnected and the modem control outputs (dtr_n, rts_n, out1_n, out2_n) are looped back to the inputs, internally. If operating in infrared mode (SIR_MODE active, MCR[6] set to one), data on the sir_out_n line is held low, while serial data output is inverted and looped back to the sir_in line.	0x0
3	R/W	UART_OUT2	OUT2. This is used to directly control the user-designated Output2 (out2_n) output. The value written to this location is inverted and driven out on out2_n, that is: 0 = out2_n de-asserted (logic 1) 1 = out2_n asserted (logic 0) Note that in Loopback mode (MCR[4] set to one), the out2_n output is held inactive high while the value of this location is internally looped back to an input.	0x0
2	R/W	UART_OUT1	OUT1. This is used to directly control the user-designated Output1 (out1_n) output. The value written to this location is inverted and driven out on out1_n, that is: 0 = out1_n de-asserted (logic 1) 1 = out1_n asserted (logic 0) Note that in Loopback mode (MCR[4] set to one), the out1_n output is held inactive high while the value of this location is internally looped back to an input.	0x0
1	R/W	UART_RTS	Request to Send. This is used to directly control the Request to Send (rts_n) output. The Request To Send (rts_n) output is used to inform the modem or data set that the UART is ready to exchange data. When Auto RTS Flow Control is not enabled (MCR[5] set to zero), the rts_n signal is set low by programming MCR[1] (RTS) to a high. In Auto Flow Control, AFCE_MODE == Enabled and active (MCR[5] set to one) and FIFOs enable (FCR[0] set to one), the rts_n output is controlled in the same way, but is also gated with the receiver FIFO threshold trigger (rts_n is inactive high when above the threshold). The rts_n signal is de-asserted when MCR[1] is set low. Note that in Loopback mode (MCR[4] set to one), the rts_n output is held inactive high while the value of this location is internally looped back to an input.	0x0
0	-	-	Reserved	0x0

Table 279: UART2_LSR_REG (0x50001114)

Bit	Mode	Symbol	Description	Reset
15:8	-	-	Reserved	0x0
7	R	UART_RFE	Receiver FIFO Error bit. This bit is only relevant when FIFOs are enabled (FCR[0] set to one). This is used to indicate if there is at least one parity error, framing error, or break indication in the FIFO. 0 = no error in RX FIFO 1 = error in RX FIFO This bit is cleared when the LSR is read and the character with the error is at the top of the receiver FIFO and there are no subsequent errors in the FIFO.	0x0
6	R	UART_TEMT	Transmitter Empty bit. If FIFOs enabled (FCR[0] set to one), this bit is set whenever the Transmitter Shift Register and the FIFO are both empty. If FIFOs are disabled, this bit is set whenever the Transmitter Holding Register and the Transmitter Shift Register are both empty.	0x1
5	R	UART_THRE	Transmit Holding Register Empty bit. If THRE mode is disabled (IER[7] set to zero) and regardless of FIFO's being implemented/enabled or not, this bit indicates that the THR or TX FIFO is empty. This bit is set whenever data is transferred from the THR or TX FIFO to the transmitter shift register and no new data has been written to the THR or TX FIFO. This also causes a THRE Interrupt to occur, if the THRE Interrupt is enabled. If both modes are active (IER[7] set to one and FCR[0] set to one respectively), the functionality is switched to indicate the transmitter FIFO is full, and no longer controls THRE interrupts, which are then controlled by the FCR[5:4] threshold setting.	0x1
4	R	UART_BI	Break Interrupt bit. This is used to indicate the detection of a break sequence on the serial input data. If in UART mode (SIR_MODE == Disabled), it is set whenever the serial input, sin, is held in a logic '0' state for longer than the sum of start time + data bits + parity + stop bits. If in infrared mode (SIR_MODE == Enabled), it is set whenever the serial input, sir_in, is continuously pulsed to logic '0' for longer than the sum of start time + data bits + parity + stop bits. A break condition on serial input causes one and only one character, consisting of all zeros, to be received by the UART. In the FIFO mode, the character associated with the break condition is carried through the FIFO and is revealed when the character is at the top of the FIFO. Reading the LSR clears the BI bit. In the non-FIFO mode, the BI indication occurs immediately and persists until the LSR is read.	0x0

Table 279: UART2_LSR_REG (0x50001114)

Bit	Mode	Symbol	Description	Reset
3	R	UART_FE	<p>Framing Error bit.</p> <p>This is used to indicate the occurrence of a framing error in the receiver. A framing error occurs when the receiver does not detect a valid STOP bit in the received data.</p> <p>In the FIFO mode, since the framing error is associated with a character received, it is revealed when the character with the framing error is at the top of the FIFO.</p> <p>When a framing error occurs, the UART tries to resynchronize. It does this by assuming that the error was due to the start bit of the next character and then continues receiving the other bit i.e. data, and/or parity and stop. It should be noted that the Framing Error (FE) bit (LSR[3]) is set if a break interrupt has occurred, as indicated by Break Interrupt (BI) bit (LSR[4]).</p> <p>0 = no framing error 1 = framing error</p> <p>Reading the LSR clears the FE bit.</p>	0x0
2	R	UART_PE	<p>Parity Error bit.</p> <p>This is used to indicate the occurrence of a parity error in the receiver if the Parity Enable (PEN) bit (LCR[3]) is set.</p> <p>In the FIFO mode, since the parity error is associated with a character received, it is revealed when the character with the parity error arrives at the top of the FIFO.</p> <p>It should be noted that the Parity Error (PE) bit (LSR[2]) is set if a break interrupt has occurred, as indicated by Break Interrupt (BI) bit (LSR[4]).</p> <p>0 = no parity error 1 = parity error</p> <p>Reading the LSR clears the PE bit.</p>	0x0
1	R	UART_OE	<p>Overrun error bit.</p> <p>This is used to indicate the occurrence of an overrun error. This occurs if a new data character was received before the previous data was read.</p> <p>In the non-FIFO mode, the OE bit is set when a new character arrives in the receiver before the previous character was read from the RBR. When this happens, the data in the RBR is overwritten. In the FIFO mode, an overrun error occurs when the FIFO is full and a new character arrives at the receiver. The data in the FIFO is retained and the data in the receive shift register is lost.</p> <p>0 = no overrun error 1 = overrun error</p> <p>Reading the LSR clears the OE bit.</p>	0x0
0	R	UART_DR	<p>Data Ready bit.</p> <p>This is used to indicate that the receiver contains at least one character in the RBR or the receiver FIFO.</p> <p>0 = no data ready 1 = data ready</p> <p>This bit is cleared when the RBR is read in non-FIFO mode, or when the receiver FIFO is empty, in FIFO mode.</p>	0x0

Table 280: UART2_MSR_REG (0x50001118)

Bit	Mode	Symbol	Description	Reset
15:5	-	-	Reserved	0x0

Table 280: UART2_MSR_REG (0x50001118)

Bit	Mode	Symbol	Description	Reset
4	R	UART_CTS	<p>Clear to Send.</p> <p>This is used to indicate the current state of the modem control line <code>cts_n</code>. This bit is the complement of <code>cts_n</code>. When the Clear to Send input (<code>cts_n</code>) is asserted it is an indication that the modem or data set is ready to exchange data with the UART Ctrl.</p> <p>0 = <code>cts_n</code> input is de-asserted (logic 1) 1 = <code>cts_n</code> input is asserted (logic 0)</p> <p>In Loopback Mode (<code>MCR[4] = 1</code>), CTS is the same as <code>MCR[1]</code> (RTS).</p>	0x0
3:1	-	-	Reserved	0x0
0	R	UART_DCTS	<p>Delta Clear to Send.</p> <p>This is used to indicate that the modem control line <code>cts_n</code> has changed since the last time the MSR was read.</p> <p>0 = no change on <code>cts_n</code> since last read of MSR 1 = change on <code>cts_n</code> since last read of MSR</p> <p>Reading the MSR clears the DCTS bit. In Loopback Mode (<code>MCR[4] = 1</code>), DCTS reflects changes on <code>MCR[1]</code> (RTS). Note, if the DCTS bit is not set and the <code>cts_n</code> signal is asserted (low) and a reset occurs (software or otherwise), then the DCTS bit is set when the reset is removed if the <code>cts_n</code> signal remains asserted.</p>	0x0

Table 281: UART2_SCR_REG (0x5000111C)

Bit	Mode	Symbol	Description	Reset
15:8	-	-	Reserved	0x0
7:0	R/W	UART_SCRATCH_P AD	This register is for programmers to use as a temporary storage space. It has no defined purpose in the UART Ctrl.	0x0

Table 282: UART2_SRBR_STHR0_REG (0x50001130)

Bit	Mode	Symbol	Description	Reset
15:8	-	-	Reserved	0x0

Table 282: UART2_SRBR_STHR0_REG (0x50001130)

Bit	Mode	Symbol	Description	Reset
7:0	R/W	SRBR_STHRX	<p>Shadow Receive Buffer Register x: This is a shadow register for the RBR and has been allocated sixteen 32-bit locations so as to accommodate burst accesses from the master. This register contains the data byte received on the serial input port (sin) in UART mode or the serial infrared input (sir_in) in infrared mode. The data in this register is valid only if the Data Ready (DR) bit in the Line status Register (LSR) is set. If FIFOs are disabled (FCR[0] set to zero), the data in the RBR must be read before the next data arrives, otherwise it will be overwritten, resulting in an overrun error. If FIFOs are enabled (FCR[0] set to one), this register accesses the head of the receive FIFO. If the receive FIFO is full and this register is not read before the next data character arrives, then the data already in the FIFO will be preserved but any incoming data will be lost. An overrun error will also occur.</p> <p>Shadow Transmit Holding Register 0: This is a shadow register for the THR and has been allocated sixteen 32-bit locations so as to accommodate burst accesses from the master. This register contains data to be transmitted on the serial output port (sout) in UART mode or the serial infrared output (sir_out_n) in infrared mode. Data should only be written to the THR when the THR Empty (THRE) bit (LSR[5]) is set. If FIFO's are disabled (FCR[0] set to zero) and THRE is set, writing a single character to the THR clears the THRE. Any additional writes to the THR before the THRE is set again causes the THR data to be overwritten. If FIFO's are enabled (FCR[0] set to one) and THRE is set, x number of characters of data may be written to the THR before the FIFO is full. The number x (default=16) is determined by the value of FIFO Depth that you set during configuration. Any attempt to write data when the FIFO is full results in the write data being lost.</p>	0x0

Table 283: UART2_SRBR_STHR1_REG (0x50001134)

Bit	Mode	Symbol	Description	Reset
15:8	-	-	Reserved	0x0

Table 283: UART2_SRBR_STHR1_REG (0x50001134)

Bit	Mode	Symbol	Description	Reset
7:0	R/W	SRBR_STHRX	<p>Shadow Receive Buffer Register x: This is a shadow register for the RBR and has been allocated sixteen 32-bit locations so as to accommodate burst accesses from the master. This register contains the data byte received on the serial input port (sin) in UART mode or the serial infrared input (sir_in) in infrared mode. The data in this register is valid only if the Data Ready (DR) bit in the Line status Register (LSR) is set. If FIFOs are disabled (FCR[0] set to zero), the data in the RBR must be read before the next data arrives, otherwise it will be overwritten, resulting in an overrun error. If FIFOs are enabled (FCR[0] set to one), this register accesses the head of the receive FIFO. If the receive FIFO is full and this register is not read before the next data character arrives, then the data already in the FIFO will be preserved but any incoming data will be lost. An overrun error will also occur.</p> <p>Shadow Transmit Holding Register 0: This is a shadow register for the THR and has been allocated sixteen 32-bit locations so as to accommodate burst accesses from the master. This register contains data to be transmitted on the serial output port (sout) in UART mode or the serial infrared output (sir_out_n) in infrared mode. Data should only be written to the THR when the THR Empty (THRE) bit (LSR[5]) is set. If FIFO's are disabled (FCR[0] set to zero) and THRE is set, writing a single character to the THR clears the THRE. Any additional writes to the THR before the THRE is set again causes the THR data to be overwritten. If FIFO's are enabled (FCR[0] set to one) and THRE is set, x number of characters of data may be written to the THR before the FIFO is full. The number x (default=16) is determined by the value of FIFO Depth that you set during configuration. Any attempt to write data when the FIFO is full results in the write data being lost.</p>	0x0

Table 284: UART2_SRBR_STHR2_REG (0x50001138)

Bit	Mode	Symbol	Description	Reset
15:8	-	-	Reserved	0x0

Table 284: UART2_SRBR_STHR2_REG (0x50001138)

Bit	Mode	Symbol	Description	Reset
7:0	R/W	SRBR_STHRX	<p>Shadow Receive Buffer Register x: This is a shadow register for the RBR and has been allocated sixteen 32-bit locations so as to accommodate burst accesses from the master. This register contains the data byte received on the serial input port (sin) in UART mode or the serial infrared input (sir_in) in infrared mode. The data in this register is valid only if the Data Ready (DR) bit in the Line status Register (LSR) is set. If FIFOs are disabled (FCR[0] set to zero), the data in the RBR must be read before the next data arrives, otherwise it will be overwritten, resulting in an overrun error. If FIFOs are enabled (FCR[0] set to one), this register accesses the head of the receive FIFO. If the receive FIFO is full and this register is not read before the next data character arrives, then the data already in the FIFO will be preserved but any incoming data will be lost. An overrun error will also occur.</p> <p>Shadow Transmit Holding Register 0: This is a shadow register for the THR and has been allocated sixteen 32-bit locations so as to accommodate burst accesses from the master. This register contains data to be transmitted on the serial output port (sout) in UART mode or the serial infrared output (sir_out_n) in infrared mode. Data should only be written to the THR when the THR Empty (THRE) bit (LSR[5]) is set. If FIFO's are disabled (FCR[0] set to zero) and THRE is set, writing a single character to the THR clears the THRE. Any additional writes to the THR before the THRE is set again causes the THR data to be overwritten. If FIFO's are enabled (FCR[0] set to one) and THRE is set, x number of characters of data may be written to the THR before the FIFO is full. The number x (default=16) is determined by the value of FIFO Depth that you set during configuration. Any attempt to write data when the FIFO is full results in the write data being lost.</p>	0x0

Table 285: UART2_SRBR_STHR3_REG (0x5000113C)

Bit	Mode	Symbol	Description	Reset
15:8	-	-	Reserved	0x0

Table 285: UART2_SRBR_STHR3_REG (0x5000113C)

Bit	Mode	Symbol	Description	Reset
7:0	R/W	SRBR_STHRX	<p>Shadow Receive Buffer Register x: This is a shadow register for the RBR and has been allocated sixteen 32-bit locations so as to accommodate burst accesses from the master. This register contains the data byte received on the serial input port (sin) in UART mode or the serial infrared input (sir_in) in infrared mode. The data in this register is valid only if the Data Ready (DR) bit in the Line status Register (LSR) is set. If FIFOs are disabled (FCR[0] set to zero), the data in the RBR must be read before the next data arrives, otherwise it will be overwritten, resulting in an overrun error. If FIFOs are enabled (FCR[0] set to one), this register accesses the head of the receive FIFO. If the receive FIFO is full and this register is not read before the next data character arrives, then the data already in the FIFO will be preserved but any incoming data will be lost. An overrun error will also occur.</p> <p>Shadow Transmit Holding Register 0: This is a shadow register for the THR and has been allocated sixteen 32-bit locations so as to accommodate burst accesses from the master. This register contains data to be transmitted on the serial output port (sout) in UART mode or the serial infrared output (sir_out_n) in infrared mode. Data should only be written to the THR when the THR Empty (THRE) bit (LSR[5]) is set. If FIFO's are disabled (FCR[0] set to zero) and THRE is set, writing a single character to the THR clears the THRE. Any additional writes to the THR before the THRE is set again causes the THR data to be overwritten. If FIFO's are enabled (FCR[0] set to one) and THRE is set, x number of characters of data may be written to the THR before the FIFO is full. The number x (default=16) is determined by the value of FIFO Depth that you set during configuration. Any attempt to write data when the FIFO is full results in the write data being lost.</p>	0x0

Table 286: UART2_SRBR_STHR4_REG (0x50001140)

Bit	Mode	Symbol	Description	Reset
15:8	-	-	Reserved	0x0

Table 286: UART2_SRBR_STHR4_REG (0x50001140)

Bit	Mode	Symbol	Description	Reset
7:0	R/W	SRBR_STHRX	<p>Shadow Receive Buffer Register x: This is a shadow register for the RBR and has been allocated sixteen 32-bit locations so as to accommodate burst accesses from the master. This register contains the data byte received on the serial input port (sin) in UART mode or the serial infrared input (sir_in) in infrared mode. The data in this register is valid only if the Data Ready (DR) bit in the Line status Register (LSR) is set. If FIFOs are disabled (FCR[0] set to zero), the data in the RBR must be read before the next data arrives, otherwise it will be overwritten, resulting in an overrun error. If FIFOs are enabled (FCR[0] set to one), this register accesses the head of the receive FIFO. If the receive FIFO is full and this register is not read before the next data character arrives, then the data already in the FIFO will be preserved but any incoming data will be lost. An overrun error will also occur.</p> <p>Shadow Transmit Holding Register 0: This is a shadow register for the THR and has been allocated sixteen 32-bit locations so as to accommodate burst accesses from the master. This register contains data to be transmitted on the serial output port (sout) in UART mode or the serial infrared output (sir_out_n) in infrared mode. Data should only be written to the THR when the THR Empty (THRE) bit (LSR[5]) is set. If FIFO's are disabled (FCR[0] set to zero) and THRE is set, writing a single character to the THR clears the THRE. Any additional writes to the THR before the THRE is set again causes the THR data to be overwritten. If FIFO's are enabled (FCR[0] set to one) and THRE is set, x number of characters of data may be written to the THR before the FIFO is full. The number x (default=16) is determined by the value of FIFO Depth that you set during configuration. Any attempt to write data when the FIFO is full results in the write data being lost.</p>	0x0

Table 287: UART2_SRBR_STHR5_REG (0x50001144)

Bit	Mode	Symbol	Description	Reset
15:8	-	-	Reserved	0x0

Table 287: UART2_SRBR_STHR5_REG (0x50001144)

Bit	Mode	Symbol	Description	Reset
7:0	R/W	SRBR_STHRX	<p>Shadow Receive Buffer Register x: This is a shadow register for the RBR and has been allocated sixteen 32-bit locations so as to accommodate burst accesses from the master. This register contains the data byte received on the serial input port (sin) in UART mode or the serial infrared input (sir_in) in infrared mode. The data in this register is valid only if the Data Ready (DR) bit in the Line status Register (LSR) is set. If FIFOs are disabled (FCR[0] set to zero), the data in the RBR must be read before the next data arrives, otherwise it will be overwritten, resulting in an overrun error. If FIFOs are enabled (FCR[0] set to one), this register accesses the head of the receive FIFO. If the receive FIFO is full and this register is not read before the next data character arrives, then the data already in the FIFO will be preserved but any incoming data will be lost. An overrun error will also occur.</p> <p>Shadow Transmit Holding Register 0: This is a shadow register for the THR and has been allocated sixteen 32-bit locations so as to accommodate burst accesses from the master. This register contains data to be transmitted on the serial output port (sout) in UART mode or the serial infrared output (sir_out_n) in infrared mode. Data should only be written to the THR when the THR Empty (THRE) bit (LSR[5]) is set. If FIFO's are disabled (FCR[0] set to zero) and THRE is set, writing a single character to the THR clears the THRE. Any additional writes to the THR before the THRE is set again causes the THR data to be overwritten. If FIFO's are enabled (FCR[0] set to one) and THRE is set, x number of characters of data may be written to the THR before the FIFO is full. The number x (default=16) is determined by the value of FIFO Depth that you set during configuration. Any attempt to write data when the FIFO is full results in the write data being lost.</p>	0x0

Table 288: UART2_SRBR_STHR6_REG (0x50001148)

Bit	Mode	Symbol	Description	Reset
15:8	-	-	Reserved	0x0

Table 288: UART2_SRBR_STHR6_REG (0x50001148)

Bit	Mode	Symbol	Description	Reset
7:0	R/W	SRBR_STHRX	<p>Shadow Receive Buffer Register x: This is a shadow register for the RBR and has been allocated sixteen 32-bit locations so as to accommodate burst accesses from the master. This register contains the data byte received on the serial input port (sin) in UART mode or the serial infrared input (sir_in) in infrared mode. The data in this register is valid only if the Data Ready (DR) bit in the Line status Register (LSR) is set. If FIFOs are disabled (FCR[0] set to zero), the data in the RBR must be read before the next data arrives, otherwise it will be overwritten, resulting in an overrun error. If FIFOs are enabled (FCR[0] set to one), this register accesses the head of the receive FIFO. If the receive FIFO is full and this register is not read before the next data character arrives, then the data already in the FIFO will be preserved but any incoming data will be lost. An overrun error will also occur.</p> <p>Shadow Transmit Holding Register 0: This is a shadow register for the THR and has been allocated sixteen 32-bit locations so as to accommodate burst accesses from the master. This register contains data to be transmitted on the serial output port (sout) in UART mode or the serial infrared output (sir_out_n) in infrared mode. Data should only be written to the THR when the THR Empty (THRE) bit (LSR[5]) is set. If FIFO's are disabled (FCR[0] set to zero) and THRE is set, writing a single character to the THR clears the THRE. Any additional writes to the THR before the THRE is set again causes the THR data to be overwritten. If FIFO's are enabled (FCR[0] set to one) and THRE is set, x number of characters of data may be written to the THR before the FIFO is full. The number x (default=16) is determined by the value of FIFO Depth that you set during configuration. Any attempt to write data when the FIFO is full results in the write data being lost.</p>	0x0

Table 289: UART2_SRBR_STHR7_REG (0x5000114C)

Bit	Mode	Symbol	Description	Reset
15:8	-	-	Reserved	0x0

Table 289: UART2_SRBR_STHR7_REG (0x5000114C)

Bit	Mode	Symbol	Description	Reset
7:0	R/W	SRBR_STHRX	<p>Shadow Receive Buffer Register x: This is a shadow register for the RBR and has been allocated sixteen 32-bit locations so as to accommodate burst accesses from the master. This register contains the data byte received on the serial input port (sin) in UART mode or the serial infrared input (sir_in) in infrared mode. The data in this register is valid only if the Data Ready (DR) bit in the Line status Register (LSR) is set. If FIFOs are disabled (FCR[0] set to zero), the data in the RBR must be read before the next data arrives, otherwise it will be overwritten, resulting in an overrun error. If FIFOs are enabled (FCR[0] set to one), this register accesses the head of the receive FIFO. If the receive FIFO is full and this register is not read before the next data character arrives, then the data already in the FIFO will be preserved but any incoming data will be lost. An overrun error will also occur.</p> <p>Shadow Transmit Holding Register 0: This is a shadow register for the THR and has been allocated sixteen 32-bit locations so as to accommodate burst accesses from the master. This register contains data to be transmitted on the serial output port (sout) in UART mode or the serial infrared output (sir_out_n) in infrared mode. Data should only be written to the THR when the THR Empty (THRE) bit (LSR[5]) is set. If FIFO's are disabled (FCR[0] set to zero) and THRE is set, writing a single character to the THR clears the THRE. Any additional writes to the THR before the THRE is set again causes the THR data to be overwritten. If FIFO's are enabled (FCR[0] set to one) and THRE is set, x number of characters of data may be written to the THR before the FIFO is full. The number x (default=16) is determined by the value of FIFO Depth that you set during configuration. Any attempt to write data when the FIFO is full results in the write data being lost.</p>	0x0

Table 290: UART2_SRBR_STHR8_REG (0x50001150)

Bit	Mode	Symbol	Description	Reset
15:8	-	-	Reserved	0x0

Table 290: UART2_SRBR_STHR8_REG (0x50001150)

Bit	Mode	Symbol	Description	Reset
7:0	R/W	SRBR_STHRX	<p>Shadow Receive Buffer Register x: This is a shadow register for the RBR and has been allocated sixteen 32-bit locations so as to accommodate burst accesses from the master. This register contains the data byte received on the serial input port (sin) in UART mode or the serial infrared input (sir_in) in infrared mode. The data in this register is valid only if the Data Ready (DR) bit in the Line status Register (LSR) is set. If FIFOs are disabled (FCR[0] set to zero), the data in the RBR must be read before the next data arrives, otherwise it will be overwritten, resulting in an overrun error. If FIFOs are enabled (FCR[0] set to one), this register accesses the head of the receive FIFO. If the receive FIFO is full and this register is not read before the next data character arrives, then the data already in the FIFO will be preserved but any incoming data will be lost. An overrun error will also occur.</p> <p>Shadow Transmit Holding Register 0: This is a shadow register for the THR and has been allocated sixteen 32-bit locations so as to accommodate burst accesses from the master. This register contains data to be transmitted on the serial output port (sout) in UART mode or the serial infrared output (sir_out_n) in infrared mode. Data should only be written to the THR when the THR Empty (THRE) bit (LSR[5]) is set. If FIFO's are disabled (FCR[0] set to zero) and THRE is set, writing a single character to the THR clears the THRE. Any additional writes to the THR before the THRE is set again causes the THR data to be overwritten. If FIFO's are enabled (FCR[0] set to one) and THRE is set, x number of characters of data may be written to the THR before the FIFO is full. The number x (default=16) is determined by the value of FIFO Depth that you set during configuration. Any attempt to write data when the FIFO is full results in the write data being lost.</p>	0x0

Table 291: UART2_SRBR_STHR9_REG (0x50001154)

Bit	Mode	Symbol	Description	Reset
15:8	-	-	Reserved	0x0

Table 291: UART2_SRBR_STHR9_REG (0x50001154)

Bit	Mode	Symbol	Description	Reset
7:0	R/W	SRBR_STHRX	<p>Shadow Receive Buffer Register x: This is a shadow register for the RBR and has been allocated sixteen 32-bit locations so as to accommodate burst accesses from the master. This register contains the data byte received on the serial input port (sin) in UART mode or the serial infrared input (sir_in) in infrared mode. The data in this register is valid only if the Data Ready (DR) bit in the Line status Register (LSR) is set. If FIFOs are disabled (FCR[0] set to zero), the data in the RBR must be read before the next data arrives, otherwise it will be overwritten, resulting in an overrun error. If FIFOs are enabled (FCR[0] set to one), this register accesses the head of the receive FIFO. If the receive FIFO is full and this register is not read before the next data character arrives, then the data already in the FIFO will be preserved but any incoming data will be lost. An overrun error will also occur.</p> <p>Shadow Transmit Holding Register 0: This is a shadow register for the THR and has been allocated sixteen 32-bit locations so as to accommodate burst accesses from the master. This register contains data to be transmitted on the serial output port (sout) in UART mode or the serial infrared output (sir_out_n) in infrared mode. Data should only be written to the THR when the THR Empty (THRE) bit (LSR[5]) is set. If FIFO's are disabled (FCR[0] set to zero) and THRE is set, writing a single character to the THR clears the THRE. Any additional writes to the THR before the THRE is set again causes the THR data to be overwritten. If FIFO's are enabled (FCR[0] set to one) and THRE is set, x number of characters of data may be written to the THR before the FIFO is full. The number x (default=16) is determined by the value of FIFO Depth that you set during configuration. Any attempt to write data when the FIFO is full results in the write data being lost.</p>	0x0

Table 292: UART2_SRBR_STHR10_REG (0x50001158)

Bit	Mode	Symbol	Description	Reset
15:8	-	-	Reserved	0x0

Table 292: UART2_SRBR_STHR10_REG (0x50001158)

Bit	Mode	Symbol	Description	Reset
7:0	R/W	SRBR_STHRX	<p>Shadow Receive Buffer Register x: This is a shadow register for the RBR and has been allocated sixteen 32-bit locations so as to accommodate burst accesses from the master. This register contains the data byte received on the serial input port (sin) in UART mode or the serial infrared input (sir_in) in infrared mode. The data in this register is valid only if the Data Ready (DR) bit in the Line status Register (LSR) is set. If FIFOs are disabled (FCR[0] set to zero), the data in the RBR must be read before the next data arrives, otherwise it will be overwritten, resulting in an overrun error. If FIFOs are enabled (FCR[0] set to one), this register accesses the head of the receive FIFO. If the receive FIFO is full and this register is not read before the next data character arrives, then the data already in the FIFO will be preserved but any incoming data will be lost. An overrun error will also occur.</p> <p>Shadow Transmit Holding Register 0: This is a shadow register for the THR and has been allocated sixteen 32-bit locations so as to accommodate burst accesses from the master. This register contains data to be transmitted on the serial output port (sout) in UART mode or the serial infrared output (sir_out_n) in infrared mode. Data should only be written to the THR when the THR Empty (THRE) bit (LSR[5]) is set. If FIFO's are disabled (FCR[0] set to zero) and THRE is set, writing a single character to the THR clears the THRE. Any additional writes to the THR before the THRE is set again causes the THR data to be overwritten. If FIFO's are enabled (FCR[0] set to one) and THRE is set, x number of characters of data may be written to the THR before the FIFO is full. The number x (default=16) is determined by the value of FIFO Depth that you set during configuration. Any attempt to write data when the FIFO is full results in the write data being lost.</p>	0x0

Table 293: UART2_SRBR_STHR11_REG (0x5000115C)

Bit	Mode	Symbol	Description	Reset
15:8	-	-	Reserved	0x0

Table 293: UART2_SRBR_STHR11_REG (0x5000115C)

Bit	Mode	Symbol	Description	Reset
7:0	R/W	SRBR_STHRX	<p>Shadow Receive Buffer Register x: This is a shadow register for the RBR and has been allocated sixteen 32-bit locations so as to accommodate burst accesses from the master. This register contains the data byte received on the serial input port (sin) in UART mode or the serial infrared input (sir_in) in infrared mode. The data in this register is valid only if the Data Ready (DR) bit in the Line status Register (LSR) is set. If FIFOs are disabled (FCR[0] set to zero), the data in the RBR must be read before the next data arrives, otherwise it will be overwritten, resulting in an overrun error. If FIFOs are enabled (FCR[0] set to one), this register accesses the head of the receive FIFO. If the receive FIFO is full and this register is not read before the next data character arrives, then the data already in the FIFO will be preserved but any incoming data will be lost. An overrun error will also occur.</p> <p>Shadow Transmit Holding Register 0: This is a shadow register for the THR and has been allocated sixteen 32-bit locations so as to accommodate burst accesses from the master. This register contains data to be transmitted on the serial output port (sout) in UART mode or the serial infrared output (sir_out_n) in infrared mode. Data should only be written to the THR when the THR Empty (THRE) bit (LSR[5]) is set. If FIFO's are disabled (FCR[0] set to zero) and THRE is set, writing a single character to the THR clears the THRE. Any additional writes to the THR before the THRE is set again causes the THR data to be overwritten. If FIFO's are enabled (FCR[0] set to one) and THRE is set, x number of characters of data may be written to the THR before the FIFO is full. The number x (default=16) is determined by the value of FIFO Depth that you set during configuration. Any attempt to write data when the FIFO is full results in the write data being lost.</p>	0x0

Table 294: UART2_SRBR_STHR12_REG (0x50001160)

Bit	Mode	Symbol	Description	Reset
15:8	-	-	Reserved	0x0

Table 294: UART2_SRBR_STHR12_REG (0x50001160)

Bit	Mode	Symbol	Description	Reset
7:0	R/W	SRBR_STHRX	<p>Shadow Receive Buffer Register x: This is a shadow register for the RBR and has been allocated sixteen 32-bit locations so as to accommodate burst accesses from the master. This register contains the data byte received on the serial input port (sin) in UART mode or the serial infrared input (sir_in) in infrared mode. The data in this register is valid only if the Data Ready (DR) bit in the Line status Register (LSR) is set. If FIFOs are disabled (FCR[0] set to zero), the data in the RBR must be read before the next data arrives, otherwise it will be overwritten, resulting in an overrun error. If FIFOs are enabled (FCR[0] set to one), this register accesses the head of the receive FIFO. If the receive FIFO is full and this register is not read before the next data character arrives, then the data already in the FIFO will be preserved but any incoming data will be lost. An overrun error will also occur.</p> <p>Shadow Transmit Holding Register 0: This is a shadow register for the THR and has been allocated sixteen 32-bit locations so as to accommodate burst accesses from the master. This register contains data to be transmitted on the serial output port (sout) in UART mode or the serial infrared output (sir_out_n) in infrared mode. Data should only be written to the THR when the THR Empty (THRE) bit (LSR[5]) is set. If FIFO's are disabled (FCR[0] set to zero) and THRE is set, writing a single character to the THR clears the THRE. Any additional writes to the THR before the THRE is set again causes the THR data to be overwritten. If FIFO's are enabled (FCR[0] set to one) and THRE is set, x number of characters of data may be written to the THR before the FIFO is full. The number x (default=16) is determined by the value of FIFO Depth that you set during configuration. Any attempt to write data when the FIFO is full results in the write data being lost.</p>	0x0

Table 295: UART2_SRBR_STHR13_REG (0x50001164)

Bit	Mode	Symbol	Description	Reset
15:8	-	-	Reserved	0x0

Table 295: UART2_SRBR_STHR13_REG (0x50001164)

Bit	Mode	Symbol	Description	Reset
7:0	R/W	SRBR_STHRX	<p>Shadow Receive Buffer Register x: This is a shadow register for the RBR and has been allocated sixteen 32-bit locations so as to accommodate burst accesses from the master. This register contains the data byte received on the serial input port (sin) in UART mode or the serial infrared input (sir_in) in infrared mode. The data in this register is valid only if the Data Ready (DR) bit in the Line status Register (LSR) is set. If FIFOs are disabled (FCR[0] set to zero), the data in the RBR must be read before the next data arrives, otherwise it will be overwritten, resulting in an overrun error. If FIFOs are enabled (FCR[0] set to one), this register accesses the head of the receive FIFO. If the receive FIFO is full and this register is not read before the next data character arrives, then the data already in the FIFO will be preserved but any incoming data will be lost. An overrun error will also occur.</p> <p>Shadow Transmit Holding Register 0: This is a shadow register for the THR and has been allocated sixteen 32-bit locations so as to accommodate burst accesses from the master. This register contains data to be transmitted on the serial output port (sout) in UART mode or the serial infrared output (sir_out_n) in infrared mode. Data should only be written to the THR when the THR Empty (THRE) bit (LSR[5]) is set. If FIFO's are disabled (FCR[0] set to zero) and THRE is set, writing a single character to the THR clears the THRE. Any additional writes to the THR before the THRE is set again causes the THR data to be overwritten. If FIFO's are enabled (FCR[0] set to one) and THRE is set, x number of characters of data may be written to the THR before the FIFO is full. The number x (default=16) is determined by the value of FIFO Depth that you set during configuration. Any attempt to write data when the FIFO is full results in the write data being lost.</p>	0x0

Table 296: UART2_SRBR_STHR14_REG (0x50001168)

Bit	Mode	Symbol	Description	Reset
15:8	-	-	Reserved	0x0

Table 296: UART2_SRBR_STHR14_REG (0x50001168)

Bit	Mode	Symbol	Description	Reset
7:0	R/W	SRBR_STHRX	<p>Shadow Receive Buffer Register x: This is a shadow register for the RBR and has been allocated sixteen 32-bit locations so as to accommodate burst accesses from the master. This register contains the data byte received on the serial input port (sin) in UART mode or the serial infrared input (sir_in) in infrared mode. The data in this register is valid only if the Data Ready (DR) bit in the Line status Register (LSR) is set. If FIFOs are disabled (FCR[0] set to zero), the data in the RBR must be read before the next data arrives, otherwise it will be overwritten, resulting in an overrun error. If FIFOs are enabled (FCR[0] set to one), this register accesses the head of the receive FIFO. If the receive FIFO is full and this register is not read before the next data character arrives, then the data already in the FIFO will be preserved but any incoming data will be lost. An overrun error will also occur.</p> <p>Shadow Transmit Holding Register 0: This is a shadow register for the THR and has been allocated sixteen 32-bit locations so as to accommodate burst accesses from the master. This register contains data to be transmitted on the serial output port (sout) in UART mode or the serial infrared output (sir_out_n) in infrared mode. Data should only be written to the THR when the THR Empty (THRE) bit (LSR[5]) is set. If FIFO's are disabled (FCR[0] set to zero) and THRE is set, writing a single character to the THR clears the THRE. Any additional writes to the THR before the THRE is set again causes the THR data to be overwritten. If FIFO's are enabled (FCR[0] set to one) and THRE is set, x number of characters of data may be written to the THR before the FIFO is full. The number x (default=16) is determined by the value of FIFO Depth that you set during configuration. Any attempt to write data when the FIFO is full results in the write data being lost.</p>	0x0

Table 297: UART2_SRBR_STHR15_REG (0x5000116C)

Bit	Mode	Symbol	Description	Reset
15:8	-	-	Reserved	0x0

Table 297: UART2_SRBR_STHR15_REG (0x5000116C)

Bit	Mode	Symbol	Description	Reset
7:0	R/W	SRBR_STHRX	<p>Shadow Receive Buffer Register x: This is a shadow register for the RBR and has been allocated sixteen 32-bit locations so as to accommodate burst accesses from the master. This register contains the data byte received on the serial input port (sin) in UART mode or the serial infrared input (sir_in) in infrared mode. The data in this register is valid only if the Data Ready (DR) bit in the Line status Register (LSR) is set. If FIFOs are disabled (FCR[0] set to zero), the data in the RBR must be read before the next data arrives, otherwise it will be overwritten, resulting in an overrun error. If FIFOs are enabled (FCR[0] set to one), this register accesses the head of the receive FIFO. If the receive FIFO is full and this register is not read before the next data character arrives, then the data already in the FIFO will be preserved but any incoming data will be lost. An overrun error will also occur.</p> <p>Shadow Transmit Holding Register 0: This is a shadow register for the THR and has been allocated sixteen 32-bit locations so as to accommodate burst accesses from the master. This register contains data to be transmitted on the serial output port (sout) in UART mode or the serial infrared output (sir_out_n) in infrared mode. Data should only be written to the THR when the THR Empty (THRE) bit (LSR[5]) is set. If FIFO's are disabled (FCR[0] set to zero) and THRE is set, writing a single character to the THR clears the THRE. Any additional writes to the THR before the THRE is set again causes the THR data to be overwritten. If FIFO's are enabled (FCR[0] set to one) and THRE is set, x number of characters of data may be written to the THR before the FIFO is full. The number x (default=16) is determined by the value of FIFO Depth that you set during configuration. Any attempt to write data when the FIFO is full results in the write data being lost.</p>	0x0

Table 298: UART2_FAR_REG (0x50001170)

Bit	Mode	Symbol	Description	Reset
0	R	UART_FAR	<p>Description: Writes will have no effect when FIFO_ACCESS == No, always readable. This register is use to enable a FIFO access mode for testing, so that the receive FIFO can be written by the master and the transmit FIFO can be read by the master when FIFO's are implemented and enabled. When FIFO's are not implemented or not enabled it allows the RBR to be written by the master and the THR to be read by the master. 0 = FIFO access mode disabled 1 = FIFO access mode enabled Note, that when the FIFO access mode is enabled/disabled, the control portion of the receive FIFO and transmit FIFO is reset and the FIFO's are treated as empty.</p>	0x0

Table 299: UART2_USR_REG (0x5000117C)

Bit	Mode	Symbol	Description	Reset
15:5	-	-	Reserved	0x0

Table 299: UART2_USR_REG (0x5000117C)

Bit	Mode	Symbol	Description	Reset
4	R	UART_RFF	Receive FIFO Full. This is used to indicate that the receive FIFO is completely full. 0 = Receive FIFO not full 1 = Receive FIFO Full This bit is cleared when the RX FIFO is no longer full.	0x0
3	R	UART_RFNE	Receive FIFO Not Empty. This is used to indicate that the receive FIFO contains one or more entries. 0 = Receive FIFO is empty 1 = Receive FIFO is not empty This bit is cleared when the RX FIFO is empty.	0x0
2	R	UART_TFE	Transmit FIFO Empty. This is used to indicate that the transmit FIFO is completely empty. 0 = Transmit FIFO is not empty 1 = Transmit FIFO is empty This bit is cleared when the TX FIFO is no longer empty.	0x1
1	R	UART_TFNF	Transmit FIFO Not Full. This is used to indicate that the transmit FIFO is not full. 0 = Transmit FIFO is full 1 = Transmit FIFO is not full This bit is cleared when the TX FIFO is full.	0x1
0	R	UART_BUSY	UART Busy. This indicates that a serial transfer is in progress, when cleared indicates that the DW_apb_uart is idle or inactive. 0 - DW_apb_uart is idle or inactive 1 - DW_apb_uart is busy (actively transferring data) Note that it is possible for the UART Busy bit to be cleared even though a new character may have been sent from another device. That is, if the DW_apb_uart has no data in the THR and RBR and there is no transmission in progress and a start bit of a new character has just reached the DW_apb_uart. This is due to the fact that a valid start is not seen until the middle of the bit period and this duration is dependent on the baud divisor that has been programmed. If a second system clock has been implemented (CLOCK_MODE == Enabled) the assertion of this bit will also be delayed by several cycles of the slower clock.	0x0

Table 300: UART2_TFL_REG (0x50001180)

Bit	Mode	Symbol	Description	Reset
15:0	R	UART_TRANSMIT_FIFO_LEVEL	Transmit FIFO Level. This indicates the number of data entries in the transmit FIFO.	0x0

Table 301: UART2_RFL_REG (0x50001184)

Bit	Mode	Symbol	Description	Reset
15:0	R	UART_RECEIVE_FIFO_LEVEL	Receive FIFO Level. This indicates the number of data entries in the receive FIFO.	0x0

Table 302: UART2_SRR_REG (0x50001188)

Bit	Mode	Symbol	Description	Reset
15:3	-	-	Reserved	0x0
2	W	UART_XFR	XMIT FIFO Reset. This is a shadow register for the XMIT FIFO Reset bit (FCR[2]). This can be used to remove the burden on software having to store previously written FCR values (which are pretty static) just to reset the transmit FIFO. This resets the control portion of the transmit FIFO and treats the FIFO as empty. Note that this bit is 'self-clearing'. It is not necessary to clear this bit.	0x0
1	W	UART_RFR	RCVR FIFO Reset. This is a shadow register for the RCVR FIFO Reset bit (FCR[1]). This can be used to remove the burden on software having to store previously written FCR values (which are pretty static) just to reset the receive FIFO. This resets the control portion of the receive FIFO and treats the FIFO as empty. Note that this bit is 'self-clearing'. It is not necessary to clear this bit.	0x0
0	W	UART_UR	UART Reset. This asynchronously resets the UART Ctrl and synchronously removes the reset assertion. For a two clock implementation both pclk and sclk domains are reset.	0x0

Table 303: UART2_SRTS_REG (0x5000118C)

Bit	Mode	Symbol	Description	Reset
15:1	-	-	Reserved	0x0
0	R/W	UART_SHADOW_REQUEST_TO_SEND	Shadow Request to Send. This is a shadow register for the RTS bit (MCR[1]), this can be used to remove the burden of having to performing a read-modify-write on the MCR. This is used to directly control the Request to Send (rts_n) output. The Request To Send (rts_n) output is used to inform the modem or data set that the UART Ctrl is ready to exchange data. When Auto RTS Flow Control is not enabled (MCR[5] = 0), the rts_n signal is set low by programming MCR[1] (RTS) to a high. In Auto Flow Control, AFCE_MODE == Enabled and active (MCR[5] = 1) and FIFOs enable (FCR[0] = 1), the rts_n output is controlled in the same way, but is also gated with the receiver FIFO threshold trigger (rts_n is inactive high when above the threshold). Note that in Loopback mode (MCR[4] = 1), the rts_n output is held inactive-high while the value of this location is internally looped back to an input.	0x0

Table 304: UART2_SBCR_REG (0x50001190)

Bit	Mode	Symbol	Description	Reset
15:1	-	-	Reserved	0x0

Table 304: UART2_SBCR_REG (0x50001190)

Bit	Mode	Symbol	Description	Reset
0	R/W	UART_SHADOW_BREAK_CONTROL	Shadow Break Control Bit. This is a shadow register for the Break bit (LCR[6]), this can be used to remove the burden of having to performing a read modify write on the LCR. This is used to cause a break condition to be transmitted to the receiving device. If set to one the serial output is forced to the spacing (logic 0) state. When not in Loopback Mode, as determined by MCR[4], the sout line is forced low until the Break bit is cleared. If SIR_MODE active (MCR[6] = 1) the sir_out_n line is continuously pulsed. When in Loopback Mode, the break condition is internally looped back to the receiver.	0x0

Table 305: UART2_SDMAM_REG (0x50001194)

Bit	Mode	Symbol	Description	Reset
15:1	-	-	Reserved	0x0
0	R/W	UART_SHADOW_DMA_MODE	Shadow DMA Mode. This is a shadow register for the DMA mode bit (FCR[3]). This can be used to remove the burden of having to store the previously written value to the FCR in memory and having to mask this value so that only the DMA Mode bit gets updated. This determines the DMA signalling mode used for the dma_tx_req_n and dma_rx_req_n output signals. 0 = mode 0 1 = mode 1	0x0

Table 306: UART2_SFE_REG (0x50001198)

Bit	Mode	Symbol	Description	Reset
15:1	-	-	Reserved	0x0
0	R/W	UART_SHADOW_FIFO_ENABLE	Shadow FIFO Enable. This is a shadow register for the FIFO enable bit (FCR[0]). This can be used to remove the burden of having to store the previously written value to the FCR in memory and having to mask this value so that only the FIFO enable bit gets updated. This enables/disables the transmit (XMIT) and receive (RCVR) FIFOs. If this bit is set to zero (disabled) after being enabled then both the XMIT and RCVR controller portion of FIFOs are reset.	0x0

Table 307: UART2_SRT_REG (0x5000119C)

Bit	Mode	Symbol	Description	Reset
15:2	-	-	Reserved	0x0

Table 307: UART2_SRT_REG (0x5000119C)

Bit	Mode	Symbol	Description	Reset
1:0	R/W	UART_SHADOW_R_CVR_TRIGGER	<p>Shadow RCVR Trigger.</p> <p>This is a shadow register for the RCVR trigger bits (FCR[7:6]). This can be used to remove the burden of having to store the previously written value to the FCR in memory and having to mask this value so that only the RCVR trigger bit gets updated.</p> <p>This is used to select the trigger level in the receiver FIFO at which the Received Data Available Interrupt is generated. It also determines when the dma_rx_req_n signal is asserted when DMA Mode (FCR[3]) = 1. The following trigger levels are supported:</p> <p>00 = 1 character in the FIFO 01 = FIFO ¼ full 10 = FIFO ½ full 11 = FIFO 2 less than full</p>	0x0

Table 308: UART2_STET_REG (0x500011A0)

Bit	Mode	Symbol	Description	Reset
15:2	-	-	Reserved	0x0
1:0	R/W	UART_SHADOW_TX_EMPTY_TRIGGER	<p>Shadow TX Empty Trigger.</p> <p>This is a shadow register for the TX empty trigger bits (FCR[5:4]). This can be used to remove the burden of having to store the previously written value to the FCR in memory and having to mask this value so that only the TX empty trigger bit gets updated.</p> <p>This is used to select the empty threshold level at which the THRE Interrupts are generated when the mode is active. The following trigger levels are supported:</p> <p>00 = FIFO empty 01 = 2 characters in the FIFO 10 = FIFO ¼ full 11 = FIFO ½ full</p>	0x0

Table 309: UART2_HTX_REG (0x500011A4)

Bit	Mode	Symbol	Description	Reset
15:1	-	-	Reserved	0x0
0	R/W	UART_HALT_TX	<p>This register is use to halt transmissions for testing, so that the transmit FIFO can be filled by the master when FIFOs are implemented and enabled.</p> <p>0 = Halt TX disabled 1 = Halt TX enabled</p> <p>Note, if FIFOs are implemented and not enabled, the setting of the halt TX register has no effect on operation.</p>	0x0

Table 310: UART2_DMASA_REG (0x500011A8)

Bit	Mode	Symbol	Description	Reset
0	W	DMASA	This register is use to perform DMA software acknowledge if a transfer needs to be terminated due to an error condition. For example, if the DMA disables the channel, then the DW_apb_uart should clear its request. This will cause the TX request, TX single, RX request and RX single signals to de-assert. Note that this bit is 'self-clearing' and it is not necessary to clear this bit.	0x0

Table 311: UART2_DLF_REG (0x500011C0)

Bit	Mode	Symbol	Description	Reset
3:0	R/W	UART_DLF	The fractional value is added to integer value set by DLH, DLL. Fractional value is determined by (Divisor Fraction value)/(2 ^{DLF_SIZE}).	0x0

Table 312: UART2_CPR_REG (0x500011F4)

Bit	Mode	Symbol	Description	Reset
15:0	R	CPR	Component Parameter Register	0x3D71

Table 313: UART2_UCV_REG (0x500011F8)

Bit	Mode	Symbol	Description	Reset
15:0	R	UCV	Component Version	0x3331352A

Table 314: UART2_CTR_REG (0x500011FC)

Bit	Mode	Symbol	Description	Reset
15:0	R	CTR	Component Type Register	0x44570110

37.11 SPI REGISTER FILE

Table 315: Register map SPI

Address	Port	Description
0x50001200	SPI_CTRL_REG	SPI control register 0
0x50001202	SPI_RX_TX_REG0	SPI RX/TX register0
0x50001204	SPI_RX_TX_REG1	SPI RX/TX register1
0x50001206	SPI_CLEAR_INT_REG	SPI clear interrupt register
0x50001208	SPI_CTRL_REG1	SPI control register 1
0x50001300	SPI2_CTRL_REG	SPI control register 0
0x50001302	SPI2_RX_TX_REG0	SPI RX/TX register0
0x50001304	SPI2_RX_TX_REG1	SPI RX/TX register1
0x50001306	SPI2_CLEAR_INT_REG	SPI clear interrupt register
0x50001308	SPI2_CTRL_REG1	SPI control register 1

Table 316: SPI_CTRL_REG (0x50001200)

Bit	Mode	Symbol	Description	Reset
15	R/W	SPI_EN_CTRL	0 = SPI_EN pin disabled in slave mode. Pin SPI_EN is don't care. 1 = SPI_EN pin enabled in slave mode.	0x0
14	R/W	SPI_MINT	0 = Disable SPI_INT_BIT to ICU 1 = Enable SPI_INT_BIT to ICU. Note that the SPI_INT interrupt is shared with AD_INT interrupt	0x0
13	R	SPI_INT_BIT	0 = RX Register or FIFO is empty. 1 = SPI interrupt. Data has been transmitted and received- Must be reset by SW by writing to SPI_CLEAR_INT_REG.	0x0
12	R	SPI_DI	Returns the actual value of pin SPI_DIN (delayed with two internal SPI clock cycles)	0x0
11	R	SPI_TXH	0 = TX-FIFO is not full, data can be written. 1 = TX-FIFO is full, data can not be written.	0x0
10	R/W	SPI_FORCE_DO	0 = normal operation 1 = Force SPIDO output level to value of SPI_DO.	0x0
9	R/W	SPI_RST	0 = normal operation 1 = Reset SPI. Same function as SPI_ON except that internal clock remain active.	0x0
8:7	R/W	SPI_WORD	00 = 8 bits mode, only SPI_RX_TX_REG0 used 01 = 16 bit mode, only SPI_RX_TX_REG0 used 10 = 32 bits mode, SPI_RX_TX_REG0 & SPI_RX_TX_REG1 used 11 = 9 bits mode. Only valid in master mode.	0x0
6	R/W	SPI_SMN	Master/slave mode 0 = Master, 1 = Slave(SPI1 only)	0x0
5	R/W	SPI_DO	Pin SPI_DO output level when SPI is idle or when SPI_FORCE_DO=1	0x0
4:3	R/W	SPI_CLK	Select SPI_CLK clock output frequency in master mode: 00 = SPI_CLK / 8 01 = SPI_CLK / 4 10 = SPI_CLK / 2 11 = SPI_CLK / 14	0x0
2	R/W	SPI_POL	Select SPI_CLK polarity. 0 = SPI_CLK is initially low. 1 = SPI_CLK is initially high.	0x0

Table 316: SPI_CTRL_REG (0x50001200)

Bit	Mode	Symbol	Description	Reset
1	R/W	SPI_PHA	Select SPI_CLK phase. See functional timing diagrams in SPI chapter	0x0
0	R/W	SPI_ON	0 = SPI Module switched off (power saving). Everything is reset except SPI_CTRL_REG0 and SPI_CTRL_REG1. When this bit is cleared the SPI will remain active in master mode until the shift register and holding register are both empty. 1 = SPI Module switched on. Should only be set after all control bits have their desired values. So two writes are needed!	0x0

Table 317: SPI_RX_TX_REG0 (0x50001202)

Bit	Mode	Symbol	Description	Reset
15:0	R0/W	SPI_DATA0	Write: SPI_TX_REG0 output register 0 (TX-FIFO) Read: SPI_RX_REG0 input register 0 (RX-FIFO) In 8 or 9 bits mode bits 15 to 8 are not used, they contain old data.	0x0

Table 318: SPI_RX_TX_REG1 (0x50001204)

Bit	Mode	Symbol	Description	Reset
15:0	R0/W	SPI_DATA1	Write: SPI_TX_REG1 output register 1 (MSB's of TX-FIFO) Read: SPI_RX_REG1 input register 1 (MSB's of RX-FIFO) In 8 or 9 or 16 bits mode bits this register is not used.	0x0

Table 319: SPI_CLEAR_INT_REG (0x50001206)

Bit	Mode	Symbol	Description	Reset
15:0	R0/W	SPI_CLEAR_INT	Writing any value to this register will clear the SPI_CTRL_REG[SPI_INT_BIT] Reading returns 0.	0x0

Table 320: SPI_CTRL_REG1 (0x50001208)

Bit	Mode	Symbol	Description	Reset
15:5	-	-	Reserved	0x0
4	R/W	SPI_9BIT_VAL	Determines the value of the first bit in 9 bits SPI mode.	0x0
3	R	SPI_BUSY	0 = The SPI is not busy with a transfer. This means that either no TX-data is available or that the transfers have been suspended due to a full RX-FIFO. The SPIx_CTRL_REG0[SPI_INT_BIT] can be used to distinguish between these situations. 1 = The SPI is busy with a transfer.	0x0
2	R/W	SPI_PRIORITY	0 = The SPI has low priority, the DMA request signals are reset after the corresponding acknowledge. 1 = The SPI has high priority, DMA request signals remain active until the FIFOS are filled/emptied, so the DMA holds the AHB bus.	0x0

Table 320: SPI_CTRL_REG1 (0x50001208)

Bit	Mode	Symbol	Description	Reset
1:0	R/W	SPI_FIFO_MODE	0: TX-FIFO and RX-FIFO used (Bidirectional mode). 1: RX-FIFO used (Read Only Mode) TX-FIFO single depth, no flow control 2: TX-FIFO used (Write Only Mode), RX-FIFO single depth, no flow control 3: No FIFOs used (backwards compatible mode)	0x3

Table 321: SPI2_CTRL_REG (0x50001300)

Bit	Mode	Symbol	Description	Reset
15	R/W	SPI_EN_CTRL	0 = SPI_EN pin disabled in slave mode. Pin SPI_EN is don't care. 1 = SPI_EN pin enabled in slave mode.	0x0
14	R/W	SPI_MINT	0 = Disable SPI_INT_BIT to ICU 1 = Enable SPI_INT_BIT to ICU. Note that the SPI_INT interrupt is shared with AD_INT interrupt	0x0
13	R	SPI_INT_BIT	0 = RX Register or FIFO is empty. 1 = SPI interrupt. Data has been transmitted and received- Must be reset by SW by writing to SPI_CLEAR_INT_REG.	0x0
12	R	SPI_DI	Returns the actual value of pin SPI_DIN (delayed with two internal SPI clock cycles)	0x0
11	R	SPI_TXH	0 = TX-FIFO is not full, data can be written. 1 = TX-FIFO is full, data can not be written.	0x0
10	R/W	SPI_FORCE_DO	0 = normal operation 1 = Force SPIDO output level to value of SPI_DO.	0x0
9	R/W	SPI_RST	0 = normal operation 1 = Reset SPI. Same function as SPI_ON except that internal clock remain active.	0x0
8:7	R/W	SPI_WORD	00 = 8 bits mode, only SPI_RX_TX_REG0 used 01 = 16 bit mode, only SPI_RX_TX_REG0 used 10 = 32 bits mode, SPI_RX_TX_REG0 & SPI_RX_TX_REG1 used 11 = 9 bits mode. Only valid in master mode.	0x0
6	R/W	SPI_SMN	Master/slave mode 0 = Master, 1 = Slave(SPI1 only)	0x0
5	R/W	SPI_DO	Pin SPI_DO output level when SPI is idle or when SPI_FORCE_DO=1	0x0
4:3	R/W	SPI_CLK	Select SPI_CLK clock output frequency in master mode: 00 = SPI_CLK / 8 01 = SPI_CLK / 4 10 = SPI_CLK / 2 11 = SPI_CLK / 14	0x0
2	R/W	SPI_POL	Select SPI_CLK polarity. 0 = SPI_CLK is initially low. 1 = SPI_CLK is initially high.	0x0
1	R/W	SPI_PHA	Select SPI_CLK phase. See functional timing diagrams in SPI chapter	0x0

Table 321: SPI2_CTRL_REG (0x50001300)

Bit	Mode	Symbol	Description	Reset
0	R/W	SPI_ON	0 = SPI Module switched off (power saving). Everything is reset except SPI_CTRL_REG0 and SPI_CTRL_REG1. When this bit is cleared the SPI will remain active in master mode until the shift register and holding register are both empty. 1 = SPI Module switched on. Should only be set after all control bits have their desired values. So two writes are needed!	0x0

Table 322: SPI2_RX_TX_REG0 (0x50001302)

Bit	Mode	Symbol	Description	Reset
15:0	R0/W	SPI_DATA0	Write: SPI_TX_REG0 output register 0 (TX-FIFO) Read: SPI_RX_REG0 input register 0 (RX-FIFO) In 8 or 9 bits mode bits 15 to 8 are not used, they contain old data.	0x0

Table 323: SPI2_RX_TX_REG1 (0x50001304)

Bit	Mode	Symbol	Description	Reset
15:0	R0/W	SPI_DATA1	Write: SPI_TX_REG1 output register 1 (MSB's of TX-FIFO) Read: SPI_RX_REG1 input register 1 (MSB's of RX-FIFO) In 8 or 9 or 16 bits mode bits this register is not used.	0x0

Table 324: SPI2_CLEAR_INT_REG (0x50001306)

Bit	Mode	Symbol	Description	Reset
15:0	R0/W	SPI_CLEAR_INT	Writing any value to this register will clear the SPI_CTRL_REG[SPI_INT_BIT] Reading returns 0.	0x0

Table 325: SPI2_CTRL_REG1 (0x50001308)

Bit	Mode	Symbol	Description	Reset
15:5	-	-	Reserved	0x0
4	R/W	SPI_9BIT_VAL	Determines the value of the first bit in 9 bits SPI mode.	0x0
3	R	SPI_BUSY	0 = The SPI is not busy with a transfer. This means that either no TX-data is available or that the transfers have been suspended due to a full RX-FIFO. The SPIx_CTRL_REG0[SPI_INT_BIT] can be used to distinguish between these situations. 1 = The SPI is busy with a transfer.	0x0
2	R/W	SPI_PRIORITY	0 = The SPI has low priority, the DMA request signals are reset after the corresponding acknowledge. 1 = The SPI has high priority, DMA request signals remain active until the FIFOs are filled/emptied, so the DMA holds the AHB bus.	0x0
1:0	R/W	SPI_FIFO_MODE	0: TX-FIFO and RX-FIFO used (Bidirectional mode). 1: RX-FIFO used (Read Only Mode) TX-FIFO single depth, no flow control 2: TX-FIFO used (Write Only Mode), RX-FIFO single depth, no flow control 3: No FIFOs used (backwards compatible mode)	0x3

37.12 I2C REGISTER FILE

Table 326: Register map I2C

Address	Port	Description
0x50001400	I2C_CON_REG	I2C Control Register
0x50001404	I2C_TAR_REG	I2C Target Address Register
0x50001408	I2C_SAR_REG	I2C Slave Address Register
0x5000140C	I2C_HS_MADDR_REG	I2C High Speed Master Mode Code Address Register
0x50001410	I2C_DATA_CMD_REG	I2C Rx/Tx Data Buffer and Command Register
0x50001414	I2C_SS_SCL_HCNT_REG	Standard Speed I2C Clock SCL High Count Register
0x50001418	I2C_SS_SCL_LCNT_REG	Standard Speed I2C Clock SCL Low Count Register
0x5000141C	I2C_FS_SCL_HCNT_REG	Fast Speed I2C Clock SCL High Count Register
0x50001420	I2C_FS_SCL_LCNT_REG	Fast Speed I2C Clock SCL Low Count Register
0x5000142C	I2C_INTR_STAT_REG	I2C Interrupt Status Register
0x50001430	I2C_INTR_MASK_REG	I2C Interrupt Mask Register
0x50001434	I2C_RAW_INTR_STAT_REG	I2C Raw Interrupt Status Register
0x50001438	I2C_RX_TL_REG	I2C Receive FIFO Threshold Register
0x5000143C	I2C_TX_TL_REG	I2C Transmit FIFO Threshold Register
0x50001440	I2C_CLR_INTR_REG	Clear Combined and Individual Interrupt Register
0x50001444	I2C_CLR_RX_UNDER_REG	Clear RX_UNDER Interrupt Register
0x50001448	I2C_CLR_RX_OVER_REG	Clear RX_OVER Interrupt Register
0x5000144C	I2C_CLR_TX_OVER_REG	Clear TX_OVER Interrupt Register
0x50001450	I2C_CLR_RD_REQ_REG	Clear RD_REQ Interrupt Register
0x50001454	I2C_CLR_TX_ABRT_REG	Clear TX_ABRT Interrupt Register
0x50001458	I2C_CLR_RX_DONE_REG	Clear RX_DONE Interrupt Register
0x5000145C	I2C_CLR_ACTIVITY_REG	Clear ACTIVITY Interrupt Register
0x50001460	I2C_CLR_STOP_DET_REG	Clear STOP_DET Interrupt Register
0x50001464	I2C_CLR_START_DET_REG	Clear START_DET Interrupt Register
0x50001468	I2C_CLR_GEN_CALL_REG	Clear GEN_CALL Interrupt Register
0x5000146C	I2C_ENABLE_REG	I2C Enable Register
0x50001470	I2C_STATUS_REG	I2C Status Register
0x50001474	I2C_TXFLR_REG	I2C Transmit FIFO Level Register
0x50001478	I2C_RXFLR_REG	I2C Receive FIFO Level Register
0x5000147C	I2C_SDA_HOLD_REG	I2C SDA Hold Time Length Register
0x50001480	I2C_TX_ABRT_SOURCE_REG	I2C Transmit Abort Source Register
0x50001488	I2C_DMA_CR_REG	DMA Control Register
0x5000148C	I2C_DMA_TDLR_REG	DMA Transmit Data Level Register
0x50001490	I2C_DMA_RDLR_REG	I2C Receive Data Level Register
0x50001494	I2C_SDA_SETUP_REG	I2C SDA Setup Register
0x50001498	I2C_ACK_GENERAL_CALL_REG	I2C ACK General Call Register
0x5000149C	I2C_ENABLE_STATUS_REG	I2C Enable Status Register
0x500014A0	I2C_IC_FS_SPKLEN_REG	I2C SS and FS spike suppression limit Size
0x500014F4	I2C_COMP_PARAM1_REG	Component Parameter Register
0x500014F6	I2C_COMP_PARAM2_REG	Component Parameter Register 2
0x500014F8	I2C_COMP_VERSION_REG	I2C Component Version Register
0x500014FA	I2C_COMP2_VERSION	I2C Component2 Version Register
0x500014FC	I2C_COMP_TYPE_REG	I2C Component Type Register

Table 326: Register map I2C

Address	Port	Description
0x500014FE	I2C_COMP_TYPE2_REG	I2C Component2 Type Register
0x50001500	I2C2_CON_REG	I2C Control Register
0x50001504	I2C2_TAR_REG	I2C Target Address Register
0x50001508	I2C2_SAR_REG	I2C Slave Address Register
0x5000150C	I2C2_HS_MADDR_REG	I2C High Speed Master Mode Code Address Register
0x50001510	I2C2_DATA_CMD_REG	I2C Rx/Tx Data Buffer and Command Register
0x50001514	I2C2_SS_SCL_HCNT_REG	Standard Speed I2C Clock SCL High Count Register
0x50001518	I2C2_SS_SCL_LCNT_REG	Standard Speed I2C Clock SCL Low Count Register
0x5000151C	I2C2_FS_SCL_HCNT_REG	Fast Speed I2C Clock SCL High Count Register
0x50001520	I2C2_FS_SCL_LCNT_REG	Fast Speed I2C Clock SCL Low Count Register
0x5000152C	I2C2_INTR_STAT_REG	I2C Interrupt Status Register
0x50001530	I2C2_INTR_MASK_REG	I2C Interrupt Mask Register
0x50001534	I2C2_RAW_INTR_STAT_REG	I2C Raw Interrupt Status Register
0x50001538	I2C2_RX_TL_REG	I2C Receive FIFO Threshold Register
0x5000153C	I2C2_TX_TL_REG	I2C Transmit FIFO Threshold Register
0x50001540	I2C2_CLR_INTR_REG	Clear Combined and Individual Interrupt Register
0x50001544	I2C2_CLR_RX_UNDER_REG	Clear RX_UNDER Interrupt Register
0x50001548	I2C2_CLR_RX_OVER_REG	Clear RX_OVER Interrupt Register
0x5000154C	I2C2_CLR_TX_OVER_REG	Clear TX_OVER Interrupt Register
0x50001550	I2C2_CLR_RD_REQ_REG	Clear RD_REQ Interrupt Register
0x50001554	I2C2_CLR_TX_ABRT_REG	Clear TX_ABRT Interrupt Register
0x50001558	I2C2_CLR_RX_DONE_REG	Clear RX_DONE Interrupt Register
0x5000155C	I2C2_CLR_ACTIVITY_REG	Clear ACTIVITY Interrupt Register
0x50001560	I2C2_CLR_STOP_DET_REG	Clear STOP_DET Interrupt Register
0x50001564	I2C2_CLR_START_DET_REG	Clear START_DET Interrupt Register
0x50001568	I2C2_CLR_GEN_CALL_REG	Clear GEN_CALL Interrupt Register
0x5000156C	I2C2_ENABLE_REG	I2C Enable Register
0x50001570	I2C2_STATUS_REG	I2C Status Register
0x50001574	I2C2_TXFLR_REG	I2C Transmit FIFO Level Register
0x50001578	I2C2_RXFLR_REG	I2C Receive FIFO Level Register
0x5000157C	I2C2_SDA_HOLD_REG	I2C SDA Hold Time Length Register
0x50001580	I2C2_TX_ABRT_SOURCE_REG	I2C Transmit Abort Source Register
0x50001588	I2C2_DMA_CR_REG	DMA Control Register
0x5000158C	I2C2_DMA_TDLR_REG	DMA Transmit Data Level Register
0x50001590	I2C2_DMA_RDLR_REG	I2C Receive Data Level Register
0x50001594	I2C2_SDA_SETUP_REG	I2C SDA Setup Register
0x50001598	I2C2_ACK_GENERAL_CALL_REG	I2C ACK General Call Register
0x5000159C	I2C2_ENABLE_STATUS_REG	I2C Enable Status Register
0x500015A0	I2C2_IC_FS_SPKLEN_REG	I2C SS and FS spike suppression limit Size
0x500015F4	I2C2_COMP_PARAM1_REG	Component Parameter Register
0x500015F6	I2C2_COMP_PARAM2_REG	Component Parameter Register 2
0x500015F8	I2C2_COMP_VERSION_REG	I2C Component Version Register

Table 326: Register map I2C

Address	Port	Description
0x500015FA	I2C2_COMP2_VERSION	I2C Component2 Version Register
0x500015FC	I2C2_COMP_TYPE_REG	I2C Component Type Register
0x500015FE	I2C2_COMP_TYPE2_REG	I2C Component2 Type Register

Table 327: I2C_CON_REG (0x50001400)

Bit	Mode	Symbol	Description	Reset
15:7	-	-	Reserved	0x0
6	R/W	I2C_SLAVE_DISABLE	Slave enabled or disabled after reset is applied, which means software does not have to configure the slave. 0=slave is enabled 1=slave is disabled Software should ensure that if this bit is written with '0', then bit 0 should also be written with a '0'.	0x1
5	R/W	I2C_RESTART_EN	Determines whether RESTART conditions may be sent when acting as a master 0= disable 1=enable	0x1
4	R/W	I2C_10BITADDR_MASTER	Controls whether the controller starts its transfers in 7- or 10-bit addressing mode when acting as a master. 0= 7-bit addressing 1= 10-bit addressing	0x1
3	R/W	I2C_10BITADDR_SLAVE	When acting as a slave, this bit controls whether the controller responds to 7- or 10-bit addresses. 0= 7-bit addressing 1= 10-bit addressing	0x1
2:1	R/W	I2C_SPEED	These bits control at which speed the controller operates. 1= standard mode (100 kbit/s) 2= fast mode (400 kbit/s)	0x2
0	R/W	I2C_MASTER_MODE	This bit controls whether the controller master is enabled. 0= master disabled 1= master enabled Software should ensure that if this bit is written with '1' then bit 6 should also be written with a '1'.	0x1

Table 328: I2C_TAR_REG (0x50001404)

Bit	Mode	Symbol	Description	Reset
15:12	-	-	Reserved	0x0
11	R/W	SPECIAL	This bit indicates whether software performs a General Call or START BYTE command. 0: ignore bit 10 GC_OR_START and use IC_TAR normally 1: perform special I2C command as specified in GC_OR_START bit	0x0

Table 328: I2C_TAR_REG (0x50001404)

Bit	Mode	Symbol	Description	Reset
10	R/W	GC_OR_START	If bit 11 (SPECIAL) is set to 1, then this bit indicates whether a General Call or START byte command is to be performed by the controller. 0: General Call Address - after issuing a General Call, only writes may be performed. Attempting to issue a read command results in setting bit 6 (TX_ABRT) of the IC_RAW_INTR_STAT register. The controller remains in General Call mode until the SPECIAL bit value (bit 11) is cleared. 1: START BYTE	0x0
9:0	R/W	IC_TAR	This is the target address for any master transaction. When transmitting a General Call, these bits are ignored. To generate a START BYTE, the CPU needs to write only once into these bits. Note: If the IC_TAR and IC_SAR are the same, loopback exists but the FIFOs are shared between master and slave, so full loopback is not feasible. Only one direction loopback mode is supported (simplex), not duplex. A master cannot transmit to itself; it can transmit to only a slave Writes to this register succeed only when IC_ENABLE[0] is set to 0	0x55

Table 329: I2C_SAR_REG (0x50001408)

Bit	Mode	Symbol	Description	Reset
15:10	-	-	Reserved	0x0
9:0	R/W	IC_SAR	The IC_SAR holds the slave address when the I2C is operating as a slave. For 7-bit addressing, only IC_SAR[6:0] is used. This register can be written only when the I2C interface is disabled, which corresponds to the IC_ENABLE register being set to 0. Writes at other times have no effect.	0x55

Table 330: I2C_HS_MADDR_REG (0x5000140C)

Bit	Mode	Symbol	Description	Reset
2:0	R/W	IIC_HS_MAR	This bit field holds the value of the I2C HS mode master code.	0x1

Table 331: I2C_DATA_CMD_REG (0x50001410)

Bit	Mode	Symbol	Description	Reset
15:9	-	-	Reserved	0x0

Table 331: I2C_DATA_CMD_REG (0x50001410)

Bit	Mode	Symbol	Description	Reset
8	R/W	CMD	<p>This bit controls whether a read or a write is performed. This bit does not control the direction when the I2C Ctrl acts as a slave. It controls only the direction when it acts as a master.</p> <p>1 = Read 0 = Write</p> <p>When a command is entered in the TX FIFO, this bit distinguishes the write and read commands. In slave-receiver mode, this bit is a "don't care" because writes to this register are not required. In slave-transmitter mode, a "0" indicates that CPU data is to be transmitted and as DAT or IC_DATA_CMD[7:0]. When programming this bit, you should remember the following: attempting to perform a read operation after a General Call command has been sent results in a TX_ABRT interrupt (bit 6 of the I2C_RAW_INTR_STAT_REG), unless bit 11 (SPECIAL) in the I2C_TAR register has been cleared.</p> <p>If a "1" is written to this bit after receiving a RD_REQ interrupt, then a TX_ABRT interrupt occurs.</p> <p>NOTE: It is possible that while attempting a master I2C read transfer on the controller, a RD_REQ interrupt may have occurred simultaneously due to a remote I2C master addressing the controller. In this type of scenario, it ignores the I2C_DATA_CMD write, generates a TX_ABRT interrupt, and waits to service the RD_REQ interrupt</p>	0x0
7:0	R/W	DAT	<p>This register contains the data to be transmitted or received on the I2C bus. If you are writing to this register and want to perform a read, bits 7:0 (DAT) are ignored by the controller. However, when you read this register, these bits return the value of data received on the controller's interface.</p>	0x0

Table 332: I2C_SS_SCL_HCNT_REG (0x50001414)

Bit	Mode	Symbol	Description	Reset
15:0	R/W	IC_SS_SCL_HCNT	<p>This register must be set before any I2C bus transaction can take place to ensure proper I/O timing. This register sets the SCL clock high-period count for standard speed. This register can be written only when the I2C interface is disabled which corresponds to the IC_ENABLE register being set to 0. Writes at other times have no effect.</p> <p>The minimum valid value is 6; hardware prevents values less than this being written, and if attempted results in 6 being set.</p> <p>NOTE: This register must not be programmed to a value higher than 65525, because the controller uses a 16-bit counter to flag an I2C bus idle condition when this counter reaches a value of IC_SS_SCL_HCNT + 10.</p>	0x48

Table 333: I2C_SS_SCL_LCNT_REG (0x50001418)

Bit	Mode	Symbol	Description	Reset
15:0	R/W	IC_SS_SCL_LCNT	This register must be set before any I2C bus transaction can take place to ensure proper I/O timing. This register sets the SCL clock low period count for standard speed. This register can be written only when the I2C interface is disabled which corresponds to the I2C_ENABLE register being set to 0. Writes at other times have no effect. The minimum valid value is 8; hardware prevents values less than this being written, and if attempted, results in 8 being set.	0x4F

Table 334: I2C_FS_SCL_HCNT_REG (0x5000141C)

Bit	Mode	Symbol	Description	Reset
15:0	R/W	IC_FS_SCL_HCNT	This register must be set before any I2C bus transaction can take place to ensure proper I/O timing. This register sets the SCL clock high-period count for fast speed. It is used in high-speed mode to send the Master Code and START BYTE or General CALL. This register can be written only when the I2C interface is disabled, which corresponds to the I2C_ENABLE register being set to 0. Writes at other times have no effect. The minimum valid value is 6; hardware prevents values less than this being written, and if attempted results in 6 being set.	0x8

Table 335: I2C_FS_SCL_LCNT_REG (0x50001420)

Bit	Mode	Symbol	Description	Reset
15:0	R/W	IC_FS_SCL_LCNT	This register must be set before any I2C bus transaction can take place to ensure proper I/O timing. This register sets the SCL clock low-period count for fast speed. It is used in high-speed mode to send the Master Code and START BYTE or General CALL. This register can be written only when the I2C interface is disabled, which corresponds to the I2C_ENABLE register being set to 0. Writes at other times have no effect. The minimum valid value is 8; hardware prevents values less than this being written, and if attempted results in 8 being set. For designs with APB_DATA_WIDTH = 8 the order of programming is important to ensure the correct operation of the controller. The lower byte must be programmed first. Then the upper byte is programmed.	0x17

Table 336: I2C_INTR_STAT_REG (0x5000142C)

Bit	Mode	Symbol	Description	Reset
15:12	-	-	Reserved	0x0
11	R	R_GEN_CALL	Set only when a General Call address is received and it is acknowledged. It stays set until it is cleared either by disabling controller or when the CPU reads bit 0 of the I2C_CLR_GEN_CALL register. The controller stores the received data in the Rx buffer.	0x0

Table 336: I2C_INTR_STAT_REG (0x5000142C)

Bit	Mode	Symbol	Description	Reset
10	R	R_START_DET	Indicates whether a START or RESTART condition has occurred on the I2C interface regardless of whether controller is operating in slave or master mode.	0x0
9	R	R_STOP_DET	Indicates whether a STOP condition has occurred on the I2C interface regardless of whether controller is operating in slave or master mode.	0x0
8	R	R_ACTIVITY	This bit captures I2C Ctrl activity and stays set until it is cleared. There are four ways to clear it: => Disabling the I2C Ctrl => Reading the IC_CLR_ACTIVITY register => Reading the IC_CLR_INTR register => System reset Once this bit is set, it stays set unless one of the four methods is used to clear it. Even if the controller module is idle, this bit remains set until cleared, indicating that there was activity on the bus.	0x0
7	R	R_RX_DONE	When the controller is acting as a slave-transmitter, this bit is set to 1 if the master does not acknowledge a transmitted byte. This occurs on the last byte of the transmission, indicating that the transmission is done.	0x0
6	R	R_TX_ABRT	This bit indicates if the controller, as an I2C transmitter, is unable to complete the intended actions on the contents of the transmit FIFO. This situation can occur both as an I2C master or an I2C slave, and is referred to as a "transmit abort". When this bit is set to 1, the I2C_TX_ABRT_SOURCE register indicates the reason why the transmit abort takes places. NOTE: The controller flushes/resets/empties the TX FIFO whenever this bit is set. The TX FIFO remains in this flushed state until the register I2C_CLR_TX_ABRT is read. Once this read is performed, the TX FIFO is then ready to accept more data bytes from the APB interface.	0x0
5	R	R_RD_REQ	This bit is set to 1 when the controller is acting as a slave and another I2C master is attempting to read data from the controller. The controller holds the I2C bus in a wait state (SCL=0) until this interrupt is serviced, which means that the slave has been addressed by a remote master that is asking for data to be transferred. The processor must respond to this interrupt and then write the requested data to the I2C_DATA_CMD register. This bit is set to 0 just after the processor reads the I2C_CLR_RD_REQ register	0x0
4	R	R_TX_EMPTY	This bit is set to 1 when the transmit buffer is at or below the threshold value set in the I2C_TX_TL register. It is automatically cleared by hardware when the buffer level goes above the threshold. When the IC_ENABLE bit 0 is 0, the TX FIFO is flushed and held in reset. There the TX FIFO looks like it has no data within it, so this bit is set to 1, provided there is activity in the master or slave state machines. When there is no longer activity, then with ic_en=0, this bit is set to 0.	0x0
3	R	R_TX_OVER	Set during transmit if the transmit buffer is filled to 32 and the processor attempts to issue another I2C command by writing to the IC_DATA_CMD register. When the module is disabled, this bit keeps its level until the master or slave state machines go into idle, and when ic_en goes to 0, this interrupt is cleared	0x0

Table 336: I2C_INTR_STAT_REG (0x5000142C)

Bit	Mode	Symbol	Description	Reset
2	R	R_RX_FULL	Set when the receive buffer reaches or goes above the RX_TL threshold in the I2C_RX_TL register. It is automatically cleared by hardware when buffer level goes below the threshold. If the module is disabled (I2C_ENABLE[0]=0), the RX FIFO is flushed and held in reset; therefore the RX FIFO is not full. So this bit is cleared once the I2C_ENABLE bit 0 is programmed with a 0, regardless of the activity that continues.	0x0
1	R	R_RX_OVER	Set if the receive buffer is completely filled to 32 and an additional byte is received from an external I2C device. The controller acknowledges this, but any data bytes received after the FIFO is full are lost. If the module is disabled (I2C_ENABLE[0]=0), this bit keeps its level until the master or slave state machines go into idle, and when ic_en goes to 0, this interrupt is cleared.	0x0
0	R	R_RX_UNDER	Set if the processor attempts to read the receive buffer when it is empty by reading from the IC_DATA_CMD register. If the module is disabled (I2C_ENABLE[0]=0), this bit keeps its level until the master or slave state machines go into idle, and when ic_en goes to 0, this interrupt is cleared.	0x0

Table 337: I2C_INTR_MASK_REG (0x50001430)

Bit	Mode	Symbol	Description	Reset
15:12	-	-	Reserved	0x0
11	R/W	M_GEN_CALL	These bits mask their corresponding interrupt status bits in the I2C_INTR_STAT register.	0x1
10	R/W	M_START_DET	These bits mask their corresponding interrupt status bits in the I2C_INTR_STAT register.	0x0
9	R/W	M_STOP_DET	These bits mask their corresponding interrupt status bits in the I2C_INTR_STAT register.	0x0
8	R/W	M_ACTIVITY	These bits mask their corresponding interrupt status bits in the I2C_INTR_STAT register.	0x0
7	R/W	M_RX_DONE	These bits mask their corresponding interrupt status bits in the I2C_INTR_STAT register.	0x1
6	R/W	M_TX_ABRT	These bits mask their corresponding interrupt status bits in the I2C_INTR_STAT register.	0x1
5	R/W	M_RD_REQ	These bits mask their corresponding interrupt status bits in the I2C_INTR_STAT register.	0x1
4	R/W	M_TX_EMPTY	These bits mask their corresponding interrupt status bits in the I2C_INTR_STAT register.	0x1
3	R/W	M_TX_OVER	These bits mask their corresponding interrupt status bits in the I2C_INTR_STAT register.	0x1
2	R/W	M_RX_FULL	These bits mask their corresponding interrupt status bits in the I2C_INTR_STAT register.	0x1
1	R/W	M_RX_OVER	These bits mask their corresponding interrupt status bits in the I2C_INTR_STAT register.	0x1
0	R/W	M_RX_UNDER	These bits mask their corresponding interrupt status bits in the I2C_INTR_STAT register.	0x1

Table 338: I2C_RAW_INTR_STAT_REG (0x50001434)

Bit	Mode	Symbol	Description	Reset
15:12	-	-	Reserved	0x0
11	R	GEN_CALL	Set only when a General Call address is received and it is acknowledged. It stays set until it is cleared either by disabling controller or when the CPU reads bit 0 of the I2C_CLR_GEN_CALL register. I2C Ctrl stores the received data in the Rx buffer.	0x0
10	R	START_DET	Indicates whether a START or RESTART condition has occurred on the I2C interface regardless of whether controller is operating in slave or master mode.	0x0
9	R	STOP_DET	Indicates whether a STOP condition has occurred on the I2C interface regardless of whether controller is operating in slave or master mode.	0x0
8	R	ACTIVITY	This bit captures I2C Ctrl activity and stays set until it is cleared. There are four ways to clear it: => Disabling the I2C Ctrl => Reading the IC_CLR_ACTIVITY register => Reading the IC_CLR_INTR register => System reset Once this bit is set, it stays set unless one of the four methods is used to clear it. Even if the controller module is idle, this bit remains set until cleared, indicating that there was activity on the bus.	0x0
7	R	RX_DONE	When the controller is acting as a slave-transmitter, this bit is set to 1 if the master does not acknowledge a transmitted byte. This occurs on the last byte of the transmission, indicating that the transmission is done.	0x0
6	R	TX_ABRT	This bit indicates if the controller, as an I2C transmitter, is unable to complete the intended actions on the contents of the transmit FIFO. This situation can occur both as an I2C master or an I2C slave, and is referred to as a "transmit abort". When this bit is set to 1, the I2C_TX_ABRT_SOURCE register indicates the reason why the transmit abort takes places. NOTE: The controller flushes/resets/empties the TX FIFO whenever this bit is set. The TX FIFO remains in this flushed state until the register I2C_CLR_TX_ABRT is read. Once this read is performed, the TX FIFO is then ready to accept more data bytes from the APB interface.	0x0
5	R	RD_REQ	This bit is set to 1 when I2C Ctrl is acting as a slave and another I2C master is attempting to read data from the controller. The controller holds the I2C bus in a wait state (SCL=0) until this interrupt is serviced, which means that the slave has been addressed by a remote master that is asking for data to be transferred. The processor must respond to this interrupt and then write the requested data to the I2C_DATA_CMD register. This bit is set to 0 just after the processor reads the I2C_CLR_RD_REQ register	0x0
4	R	TX_EMPTY	This bit is set to 1 when the transmit buffer is at or below the threshold value set in the I2C_TX_TL register. It is automatically cleared by hardware when the buffer level goes above the threshold. When the IC_ENABLE bit 0 is 0, the TX FIFO is flushed and held in reset. There the TX FIFO looks like it has no data within it, so this bit is set to 1, provided there is activity in the master or slave state machines. When there is no longer activity, then with ic_en=0, this bit is set to 0.	0x0

Table 338: I2C_RAW_INTR_STAT_REG (0x50001434)

Bit	Mode	Symbol	Description	Reset
3	R	TX_OVER	Set during transmit if the transmit buffer is filled to 32 and the processor attempts to issue another I2C command by writing to the IC_DATA_CMD register. When the module is disabled, this bit keeps its level until the master or slave state machines go into idle, and when ic_en goes to 0, this interrupt is cleared	0x0
2	R	RX_FULL	Set when the receive buffer reaches or goes above the RX_TL threshold in the I2C_RX_TL register. It is automatically cleared by hardware when buffer level goes below the threshold. If the module is disabled (I2C_ENABLE[0]=0), the RX FIFO is flushed and held in reset; therefore the RX FIFO is not full. So this bit is cleared once the I2C_ENABLE bit 0 is programmed with a 0, regardless of the activity that continues.	0x0
1	R	RX_OVER	Set if the receive buffer is completely filled to 32 and an additional byte is received from an external I2C device. The controller acknowledges this, but any data bytes received after the FIFO is full are lost. If the module is disabled (I2C_ENABLE[0]=0), this bit keeps its level until the master or slave state machines go into idle, and when ic_en goes to 0, this interrupt is cleared.	0x0
0	R	RX_UNDER	Set if the processor attempts to read the receive buffer when it is empty by reading from the IC_DATA_CMD register. If the module is disabled (I2C_ENABLE[0]=0), this bit keeps its level until the master or slave state machines go into idle, and when ic_en goes to 0, this interrupt is cleared.	0x0

Table 339: I2C_RX_TL_REG (0x50001438)

Bit	Mode	Symbol	Description	Reset
15:5	-	-	Reserved	0x0
4:0	R/W	RX_TL	Receive FIFO Threshold Level Controls the level of entries (or above) that triggers the RX_FULL interrupt (bit 2 in I2C_RAW_INTR_STAT register). The valid range is 0-31, with the additional restriction that hardware does not allow this value to be set to a value larger than the depth of the buffer. If an attempt is made to do that, the actual value set will be the maximum depth of the buffer. A value of 0 sets the threshold for 1 entry, and a value of 31 sets the threshold for 32 entries.	0x0

Table 340: I2C_TX_TL_REG (0x5000143C)

Bit	Mode	Symbol	Description	Reset
15:5	-	-	Reserved	0x0
4:0	R/W	RX_TL	Transmit FIFO Threshold Level Controls the level of entries (or below) that trigger the TX_EMPTY interrupt (bit 4 in I2C_RAW_INTR_STAT register). The valid range is 0-31, with the additional restriction that it may not be set to value larger than the depth of the buffer. If an attempt is made to do that, the actual value set will be the maximum depth of the buffer. A value of 0 sets the threshold for 0 entries, and a value of 31 sets the threshold for 32 entries..	0x0

Table 341: I2C_CLR_INTR_REG (0x50001440)

Bit	Mode	Symbol	Description	Reset
15:1	-	-	Reserved	0x0
0	R	CLR_INTR	Read this register to clear the combined interrupt, all individual interrupts, and the I2C_TX_ABRT_SOURCE register. This bit does not clear hardware clearable interrupts but software clearable interrupts. Refer to Bit 9 of the I2C_TX_ABRT_SOURCE register for an exception to clearing I2C_TX_ABRT_SOURCE	0x0

Table 342: I2C_CLR_RX_UNDER_REG (0x50001444)

Bit	Mode	Symbol	Description	Reset
15:1	-	-	Reserved	0x0
0	R	CLR_RX_UNDER	Read this register to clear the RX_UNDER interrupt (bit 0) of the I2C_RAW_INTR_STAT register.	0x0

Table 343: I2C_CLR_RX_OVER_REG (0x50001448)

Bit	Mode	Symbol	Description	Reset
15:1	-	-	Reserved	0x0
0	R	CLR_RX_OVER	Read this register to clear the RX_OVER interrupt (bit 1) of the I2C_RAW_INTR_STAT register.	0x0

Table 344: I2C_CLR_TX_OVER_REG (0x5000144C)

Bit	Mode	Symbol	Description	Reset
15:1	-	-	Reserved	0x0
0	R	CLR_TX_OVER	Read this register to clear the TX_OVER interrupt (bit 3) of the I2C_RAW_INTR_STAT register.	0x0

Table 345: I2C_CLR_RD_REQ_REG (0x50001450)

Bit	Mode	Symbol	Description	Reset
15:1	-	-	Reserved	0x0
0	R	CLR_RD_REQ	Read this register to clear the RD_REQ interrupt (bit 5) of the I2C_RAW_INTR_STAT register.	0x0

Table 346: I2C_CLR_TX_ABRT_REG (0x50001454)

Bit	Mode	Symbol	Description	Reset
15:1	-	-	Reserved	0x0
0	R	CLR_TX_ABRT	Read this register to clear the TX_ABRT interrupt (bit 6) of the IC_RAW_INTR_STAT register, and the I2C_TX_ABRT_SOURCE register. This also releases the TX FIFO from the flushed/reset state, allowing more writes to the TX FIFO. Refer to Bit 9 of the I2C_TX_ABRT_SOURCE register for an exception to clearing IC_TX_ABRT_SOURCE.	0x0

Table 347: I2C_CLR_RX_DONE_REG (0x50001458)

Bit	Mode	Symbol	Description	Reset
15:1	-	-	Reserved	0x0
0	R	CLR_RX_DONE	Read this register to clear the RX_DONE interrupt (bit 7) of the I2C_RAW_INTR_STAT register.	0x0

Table 348: I2C_CLR_ACTIVITY_REG (0x5000145C)

Bit	Mode	Symbol	Description	Reset
15:1	-	-	Reserved	0x0
0	R	CLR_ACTIVITY	Reading this register clears the ACTIVITY interrupt if the I2C is not active anymore. If the I2C module is still active on the bus, the ACTIVITY interrupt bit continues to be set. It is automatically cleared by hardware if the module is disabled and if there is no further activity on the bus. The value read from this register to get status of the ACTIVITY interrupt (bit 8) of the IC_RAW_INTR_STAT register	0x0

Table 349: I2C_CLR_STOP_DET_REG (0x50001460)

Bit	Mode	Symbol	Description	Reset
15:1	-	-	Reserved	0x0
0	R	CLR_ACTIVITY	Reading this register clears the ACTIVITY interrupt if the I2C is not active anymore. If the I2C module is still active on the bus, the ACTIVITY interrupt bit continues to be set. It is automatically cleared by hardware if the module is disabled and if there is no further activity on the bus. The value read from this register to get status of the ACTIVITY interrupt (bit 8) of the IC_RAW_INTR_STAT register.	0x0

Table 350: I2C_CLR_START_DET_REG (0x50001464)

Bit	Mode	Symbol	Description	Reset
15:1	-	-	Reserved	0x0
0	R	CLR_START_DET	Read this register to clear the START_DET interrupt (bit 10) of the IC_RAW_INTR_STAT register.	0x0

Table 351: I2C_CLR_GEN_CALL_REG (0x50001468)

Bit	Mode	Symbol	Description	Reset
15:1	-	-	Reserved	0x0
0	R	CLR_GEN_CALL	Read this register to clear the GEN_CALL interrupt (bit 11) of I2C_RAW_INTR_STAT register.	0x0

Table 352: I2C_ENABLE_REG (0x5000146C)

Bit	Mode	Symbol	Description	Reset
15:1	-	-	Reserved	0x0

Table 352: I2C_ENABLE_REG (0x5000146C)

Bit	Mode	Symbol	Description	Reset
0	R/W	CTRL_ENABLE	<p>Controls whether the controller is enabled.</p> <p>0: Disables the controller (TX and RX FIFOs are held in an erased state)</p> <p>1: Enables the controller</p> <p>Software can disable the controller while it is active. However, it is important that care be taken to ensure that the controller is disabled properly. When the controller is disabled, the following occurs:</p> <ul style="list-style-type: none"> * The TX FIFO and RX FIFO get flushed. * Status bits in the IC_INTR_STAT register are still active until the controller goes into IDLE state. <p>If the module is transmitting, it stops as well as deletes the contents of the transmit buffer after the current transfer is complete. If the module is receiving, the controller stops the current transfer at the end of the current byte and does not acknowledge the transfer.</p> <p>There is a two ic_clk delay when enabling or disabling the controller</p>	0x0

Table 353: I2C_STATUS_REG (0x50001470)

Bit	Mode	Symbol	Description	Reset
15:7	-	-	Reserved	0x0
6	R	SLV_ACTIVITY	<p>Slave FSM Activity Status. When the Slave Finite State Machine (FSM) is not in the IDLE state, this bit is set.</p> <p>0: Slave FSM is in IDLE state so the Slave part of the controller is not Active</p> <p>1: Slave FSM is not in IDLE state so the Slave part of the controller is Active</p>	0x0
5	R	MST_ACTIVITY	<p>Master FSM Activity Status. When the Master Finite State Machine (FSM) is not in the IDLE state, this bit is set.</p> <p>0: Master FSM is in IDLE state so the Master part of the controller is not Active</p> <p>1: Master FSM is not in IDLE state so the Master part of the controller is Active</p>	0x0
4	R	RFF	<p>Receive FIFO Completely Full. When the receive FIFO is completely full, this bit is set. When the receive FIFO contains one or more empty location, this bit is cleared.</p> <p>0: Receive FIFO is not full</p> <p>1: Receive FIFO is full</p>	0x0
3	R	RFNE	<p>Receive FIFO Not Empty. This bit is set when the receive FIFO contains one or more entries; it is cleared when the receive FIFO is empty.</p> <p>0: Receive FIFO is empty</p> <p>1: Receive FIFO is not empty</p>	0x0
2	R	TFE	<p>Transmit FIFO Completely Empty. When the transmit FIFO is completely empty, this bit is set. When it contains one or more valid entries, this bit is cleared. This bit field does not request an interrupt.</p> <p>0: Transmit FIFO is not empty</p> <p>1: Transmit FIFO is empty</p>	0x1
1	R	TFNF	<p>Transmit FIFO Not Full. Set when the transmit FIFO contains one or more empty locations, and is cleared when the FIFO is full.</p> <p>0: Transmit FIFO is full</p> <p>1: Transmit FIFO is not full</p>	0x1

Table 353: I2C_STATUS_REG (0x50001470)

Bit	Mode	Symbol	Description	Reset
0	R	I2C_ACTIVITY	I2C Activity Status.	0x0

Table 354: I2C_TXFLR_REG (0x50001474)

Bit	Mode	Symbol	Description	Reset
15:6	-	-	Reserved	0x0
5:0	R	TXFLR	Transmit FIFO Level. Contains the number of valid data entries in the transmit FIFO. Size is constrained by the TXFLR value	0x0

Table 355: I2C_RXFLR_REG (0x50001478)

Bit	Mode	Symbol	Description	Reset
15:6	-	-	Reserved	0x0
5:0	R	RXFLR	Receive FIFO Level. Contains the number of valid data entries in the receive FIFO. Size is constrained by the RXFLR value	0x0

Table 356: I2C_SDA_HOLD_REG (0x5000147C)

Bit	Mode	Symbol	Description	Reset
15:0	R/W	IC_SDA_HOLD	SDA Hold time	0x1

Table 357: I2C_TX_ABRT_SOURCE_REG (0x50001480)

Bit	Mode	Symbol	Description	Reset
15	R	ABRT_SLVRD_INTX	1: When the processor side responds to a slave mode request for data to be transmitted to a remote master and user writes a 1 in CMD (bit 8) of I2C_DATA_CMD register	0x0
14	R	ABRT_SLV_ARBLOST	1: Slave lost the bus while transmitting data to a remote master. I2C_TX_ABRT_SOURCE[12] is set at the same time. Note: Even though the slave never "owns" the bus, something could go wrong on the bus. This is a fail safe check. For instance, during a data transmission at the low-to-high transition of SCL, if what is on the data bus is not what is supposed to be transmitted, then the controller no longer own the bus.	0x0
13	R	ABRT_SLVFLUSH_TXFIFO	1: Slave has received a read command and some data exists in the TX FIFO so the slave issues a TX_ABRT interrupt to flush old data in TX FIFO.	0x0
12	R	ARB_LOST	1: Master has lost arbitration, or if I2C_TX_ABRT_SOURCE[14] is also set, then the slave transmitter has lost arbitration. Note: I2C can be both master and slave at the same time.	0x0
11	R	ABRT_MASTER_DIS	1: User tries to initiate a Master operation with the Master mode disabled.	0x0
10	R	ABRT_10B_RD_NORSTR	1: The restart is disabled (IC_RESTART_EN bit (I2C_CON[5]) = 0) and the master sends a read command in 10-bit addressing mode.	0x0

Table 357: I2C_TX_ABRT_SOURCE_REG (0x50001480)

Bit	Mode	Symbol	Description	Reset
9	R	ABRT_SBYTE_NORSTRT	To clear Bit 9, the source of the ABRT_SBYTE_NORSTRT must be fixed first; restart must be enabled (I2C_CON[5]=1), the SPECIAL bit must be cleared (I2C_TAR[11]), or the GC_OR_START bit must be cleared (I2C_TAR[10]). Once the source of the ABRT_SBYTE_NORSTRT is fixed, then this bit can be cleared in the same manner as other bits in this register. If the source of the ABRT_SBYTE_NORSTRT is not fixed before attempting to clear this bit, bit 9 clears for one cycle and then gets re-asserted. 1: The restart is disabled (IC_RESTART_EN bit (I2C_CON[5]) = 0) and the user is trying to send a START Byte.	0x0
8	R	ABRT_HS_NORSTR T	1: The restart is disabled (IC_RESTART_EN bit (I2C_CON[5]) = 0) and the user is trying to use the master to transfer data in High Speed mode	0x0
7	R	ABRT_SBYTE_ACK DET	1: Master has sent a START Byte and the START Byte was acknowledged (wrong behavior).	0x0
6	R	ABRT_HS_ACKDET	1: Master is in High Speed mode and the High Speed Master code was acknowledged (wrong behavior).	0x0
5	R	ABRT_GCALL_REA D	1: the controller in master mode sent a General Call but the user programmed the byte following the General Call to be a read from the bus (IC_DATA_CMD[9] is set to 1).	0x0
4	R	ABRT_GCALL_NOA CK	1: the controller in master mode sent a General Call and no slave on the bus acknowledged the General Call.	0x0
3	R	ABRT_TXDATA_NO ACK	1: This is a master-mode only bit. Master has received an acknowledgement for the address, but when it sent data byte(s) following the address, it did not receive an acknowledge from the remote slave(s).	0x0
2	R	ABRT_10ADDR2_N OACK	1: Master is in 10-bit address mode and the second address byte of the 10-bit address was not acknowledged by any slave.	0x0
1	R	ABRT_10ADDR1_N OACK	1: Master is in 10-bit address mode and the first 10-bit address byte was not acknowledged by any slave.	0x0
0	R	ABRT_7B_ADDR_N OACK	1: Master is in 7-bit addressing mode and the address sent was not acknowledged by any slave.	0x0

Table 358: I2C_DMA_CR_REG (0x50001488)

Bit	Mode	Symbol	Description	Reset
1	R/W	TDMAE	Transmit DMA Enable. //This bit enables/disables the transmit FIFO DMA channel. 0 = Transmit DMA disabled 1 = Transmit DMA enabled	0x0
0	R/W	RDMAE	Receive DMA Enable. This bit enables/disables the receive FIFO DMA channel. 0 = Receive DMA disabled 1 = Receive DMA enabled	0x0

Table 359: I2C_DMA_TDLR_REG (0x5000148C)

Bit	Mode	Symbol	Description	Reset
4:0	R/W	DMATDL	Transmit Data Level. This bit field controls the level at which a DMA request is made by the transmit logic. It is equal to the watermark level; that is, the dma_tx_req signal is generated when the number of valid data entries in the transmit FIFO is equal to or below this field value, and TDMAE = 1.	0x0

Table 360: I2C_DMA_RDLR_REG (0x50001490)

Bit	Mode	Symbol	Description	Reset
4:0	R/W	DMARDL	Receive Data Level. This bit field controls the level at which a DMA request is made by the receive logic. The watermark level = DMARDL+1; that is, dma_rx_req is generated when the number of valid data entries in the receive FIFO is equal to or more than this field value + 1, and RDMAE =1. For instance, when DMARDL is 0, then dma_rx_req is asserted when 1 or more data entries are present in the receive FIFO.	0x0

Table 361: I2C_SDA_SETUP_REG (0x50001494)

Bit	Mode	Symbol	Description	Reset
15:8	-	-	Reserved	0x0
7:0	R/W	SDA_SETUP	SDA Setup. This register controls the amount of time delay (number of I2C clock periods) between the rising edge of SCL and SDA changing by holding SCL low when I2C block services a read request while operating as a slave-transmitter. The relevant I2C requirement is tSU:DAT (note 4) as detailed in the I2C Bus Specification. This register must be programmed with a value equal to or greater than 2. It is recommended that if the required delay is 1000ns, then for an I2C frequency of 10 MHz, IC_SDA_SETUP should be programmed to a value of 11. Writes to this register succeed only when IC_ENABLE[0] = 0.	0x64

Table 362: I2C_ACK_GENERAL_CALL_REG (0x50001498)

Bit	Mode	Symbol	Description	Reset
15:1	-	-	Reserved	0x0
0	R/W	ACK_GEN_CALL	ACK General Call. When set to 1, I2C Ctrl responds with a ACK (by asserting ic_data_oe) when it receives a General Call. When set to 0, the controller does not generate General Call interrupts.	0x0

Table 363: I2C_ENABLE_STATUS_REG (0x5000149C)

Bit	Mode	Symbol	Description	Reset
15:3	-	-	Reserved	0x0

Table 363: I2C_ENABLE_STATUS_REG (0x5000149C)

Bit	Mode	Symbol	Description	Reset
2	R	SLV_RX_DATA_LOST	Slave Received Data Lost. This bit indicates if a Slave-Receiver operation has been aborted with at least one data byte received from an I2C transfer due to the setting of IC_ENABLE from 1 to 0. When read as 1, the controller is deemed to have been actively engaged in an aborted I2C transfer (with matching address) and the data phase of the I2C transfer has been entered, even though a data byte has been responded with a NACK. NOTE: If the remote I2C master terminates the transfer with a STOP condition before the controller has a chance to NACK a transfer, and IC_ENABLE has been set to 0, then this bit is also set to 1. When read as 0, the controller is deemed to have been disabled without being actively involved in the data phase of a Slave-Receiver transfer. NOTE: The CPU can safely read this bit when IC_EN (bit 0) is read as 0.	0x0
1	R	SLV_DISABLED_WHILE_BUSY	Slave Disabled While Busy (Transmit, Receive). This bit indicates if a potential or active Slave operation has been aborted due to the setting of the IC_ENABLE register from 1 to 0. This bit is set when the CPU writes a 0 to the IC_ENABLE register while: (a) I2C Ctrl is receiving the address byte of the Slave-Transmitter operation from a remote master; OR, (b) address and data bytes of the Slave-Receiver operation from a remote master. When read as 1, the controller is deemed to have forced a NACK during any part of an I2C transfer, irrespective of whether the I2C address matches the slave address set in I2C Ctrl (IC_SAR register) OR if the transfer is completed before IC_ENABLE is set to 0 but has not taken effect. NOTE: If the remote I2C master terminates the transfer with a STOP condition before the the controller has a chance to NACK a transfer, and IC_ENABLE has been set to 0, then this bit will also be set to 1. When read as 0, the controller is deemed to have been disabled when there is master activity, or when the I2C bus is idle. NOTE: The CPU can safely read this bit when IC_EN (bit 0) is read as 0.	0x0
0	R	IC_EN	ic_en Status. This bit always reflects the value driven on the output port ic_en. When read as 1, the controller is deemed to be in an enabled state. When read as 0, the controller is deemed completely inactive. NOTE: The CPU can safely read this bit anytime. When this bit is read as 0, the CPU can safely read SLV_RX_DATA_LOST (bit 2) and SLV_DISABLED_WHILE_BUSY (bit 1).	0x0

Table 364: I2C_IC_FS_SPKLEN_REG (0x500014A0)

Bit	Mode	Symbol	Description	Reset
15:8	-	-	Reserved	0x0

Table 364: I2C_IC_FS_SPKLEN_REG (0x500014A0)

Bit	Mode	Symbol	Description	Reset
7:0	R/W	IC_FS_SPKLEN	This register must be set before any I2C bus transaction can take place to ensure stable operation. This register sets the duration, measured in ic_clk cycles, of the longest spike in the SCL or SDA lines that will be filtered out by the spike suppression logic. This register can be written only when the I2C interface is disabled which corresponds to the IC_ENABLE register being set to 0. Writes at other times have no effect. The minimum valid value is 2; hardware prevents values less than this being written, and if attempted results in 2 being set.	0x1

Table 365: I2C_COMP_PARAM1_REG (0x500014F4)

Bit	Mode	Symbol	Description	Reset
-	-	-	Undefined	-

Table 366: I2C_COMP_PARAM2_REG (0x500014F6)

Bit	Mode	Symbol	Description	Reset
-	-	-	Undefined	-

Table 367: I2C_COMP_VERSION_REG (0x500014F8)

Bit	Mode	Symbol	Description	Reset
-	-	-	Undefined	-

Table 368: I2C_COMP2_VERSION (0x500014FA)

Bit	Mode	Symbol	Description	Reset
-	-	-	Undefined	-

Table 369: I2C_COMP_TYPE_REG (0x500014FC)

Bit	Mode	Symbol	Description	Reset
-	-	-	Undefined	-

Table 370: I2C_COMP_TYPE2_REG (0x500014FE)

Bit	Mode	Symbol	Description	Reset
-	-	-	Undefined	-

Table 371: I2C2_CON_REG (0x50001500)

Bit	Mode	Symbol	Description	Reset
15:7	-	-	Reserved	0x0
6	R/W	I2C_SLAVE_DISABLE	Slave enabled or disabled after reset is applied, which means software does not have to configure the slave. 0=slave is enabled 1=slave is disabled Software should ensure that if this bit is written with '0', then bit 0 should also be written with a '0'.	0x1

Table 371: I2C2_CON_REG (0x50001500)

Bit	Mode	Symbol	Description	Reset
5	R/W	I2C_RESTART_EN	Determines whether RESTART conditions may be sent when acting as a master 0= disable 1=enable	0x1
4	R/W	I2C_10BITADDR_MASTER	Controls whether the controller starts its transfers in 7- or 10-bit addressing mode when acting as a master. 0= 7-bit addressing 1= 10-bit addressing	0x1
3	R/W	I2C_10BITADDR_SLAVE	When acting as a slave, this bit controls whether the controller responds to 7- or 10-bit addresses. 0= 7-bit addressing 1= 10-bit addressing	0x1
2:1	R/W	I2C_SPEED	These bits control at which speed the controller operates. 1= standard mode (100 kbit/s) 2= fast mode (400 kbit/s)	0x2
0	R/W	I2C_MASTER_MODE	This bit controls whether the controller master is enabled. 0= master disabled 1= master enabled Software should ensure that if this bit is written with '1' then bit 6 should also be written with a '1'.	0x1

Table 372: I2C2_TAR_REG (0x50001504)

Bit	Mode	Symbol	Description	Reset
15:12	-	-	Reserved	0x0
11	R/W	SPECIAL	This bit indicates whether software performs a General Call or START BYTE command. 0: ignore bit 10 GC_OR_START and use IC_TAR normally 1: perform special I2C command as specified in GC_OR_START bit	0x0
10	R/W	GC_OR_START	If bit 11 (SPECIAL) is set to 1, then this bit indicates whether a General Call or START byte command is to be performed by the controller. 0: General Call Address - after issuing a General Call, only writes may be performed. Attempting to issue a read command results in setting bit 6 (TX_ABRT) of the IC_RAW_INTR_STAT register. The controller remains in General Call mode until the SPECIAL bit value (bit 11) is cleared. 1: START BYTE	0x0
9:0	R/W	IC_TAR	This is the target address for any master transaction. When transmitting a General Call, these bits are ignored. To generate a START BYTE, the CPU needs to write only once into these bits. Note: If the IC_TAR and IC_SAR are the same, loopback exists but the FIFOs are shared between master and slave, so full loopback is not feasible. Only one direction loopback mode is supported (simplex), not duplex. A master cannot transmit to itself; it can transmit to only a slave Writes to this register succeed only when IC_ENABLE[0] is set to 0	0x55

Table 373: I2C2_SAR_REG (0x50001508)

Bit	Mode	Symbol	Description	Reset
15:10	-	-	Reserved	0x0
9:0	R/W	IC_SAR	The IC_SAR holds the slave address when the I2C is operating as a slave. For 7-bit addressing, only IC_SAR[6:0] is used. This register can be written only when the I2C interface is disabled, which corresponds to the IC_ENABLE register being set to 0. Writes at other times have no effect.	0x55

Table 374: I2C2_HS_MADDR_REG (0x5000150C)

Bit	Mode	Symbol	Description	Reset
2:0	R/W	IIC_HS_MAR	This bit field holds the value of the I2C HS mode master code.	0x1

Table 375: I2C2_DATA_CMD_REG (0x50001510)

Bit	Mode	Symbol	Description	Reset
15:9	-	-	Reserved	0x0
8	R/W	CMD	<p>This bit controls whether a read or a write is performed. This bit does not control the direction when the I2C Ctrl acts as a slave. It controls only the direction when it acts as a master.</p> <p>1 = Read 0 = Write</p> <p>When a command is entered in the TX FIFO, this bit distinguishes the write and read commands. In slave-receiver mode, this bit is a "don't care" because writes to this register are not required. In slave-transmitter mode, a "0" indicates that CPU data is to be transmitted and as DAT or IC_DATA_CMD[7:0]. When programming this bit, you should remember the following: attempting to perform a read operation after a General Call command has been sent results in a TX_ABRT interrupt (bit 6 of the I2C_RAW_INTR_STAT_REG), unless bit 11 (SPECIAL) in the I2C_TAR register has been cleared.</p> <p>If a "1" is written to this bit after receiving a RD_REQ interrupt, then a TX_ABRT interrupt occurs.</p> <p>NOTE: It is possible that while attempting a master I2C read transfer on the controller, a RD_REQ interrupt may have occurred simultaneously due to a remote I2C master addressing the controller. In this type of scenario, it ignores the I2C_DATA_CMD write, generates a TX_ABRT interrupt, and waits to service the RD_REQ interrupt</p>	0x0
7:0	R/W	DAT	This register contains the data to be transmitted or received on the I2C bus. If you are writing to this register and want to perform a read, bits 7:0 (DAT) are ignored by the controller. However, when you read this register, these bits return the value of data received on the controller's interface.	0x0

Table 376: I2C2_SS_SCL_HCNT_REG (0x50001514)

Bit	Mode	Symbol	Description	Reset
15:0	R/W	IC_SS_SCL_HCNT	<p>This register must be set before any I2C bus transaction can take place to ensure proper I/O timing. This register sets the SCL clock high-period count for standard speed. This register can be written only when the I2C interface is disabled which corresponds to the IC_ENABLE register being set to 0. Writes at other times have no effect.</p> <p>The minimum valid value is 6; hardware prevents values less than this being written, and if attempted results in 6 being set.</p> <p>NOTE: This register must not be programmed to a value higher than 65525, because the controller uses a 16-bit counter to flag an I2C bus idle condition when this counter reaches a value of IC_SS_SCL_HCNT + 10.</p>	0x48

Table 377: I2C2_SS_SCL_LCNT_REG (0x50001518)

Bit	Mode	Symbol	Description	Reset
15:0	R/W	IC_SS_SCL_LCNT	<p>This register must be set before any I2C bus transaction can take place to ensure proper I/O timing. This register sets the SCL clock low period count for standard speed.</p> <p>This register can be written only when the I2C interface is disabled which corresponds to the I2C_ENABLE register being set to 0. Writes at other times have no effect.</p> <p>The minimum valid value is 8; hardware prevents values less than this being written, and if attempted, results in 8 being set.</p>	0x4F

Table 378: I2C2_FS_SCL_HCNT_REG (0x5000151C)

Bit	Mode	Symbol	Description	Reset
15:0	R/W	IC_FS_SCL_HCNT	<p>This register must be set before any I2C bus transaction can take place to ensure proper I/O timing. This register sets the SCL clock high-period count for fast speed. It is used in high-speed mode to send the Master Code and START BYTE or General CALL. This register can be written only when the I2C interface is disabled, which corresponds to the I2C_ENABLE register being set to 0. Writes at other times have no effect.</p> <p>The minimum valid value is 6; hardware prevents values less than this being written, and if attempted results in 6 being set.</p>	0x8

Table 379: I2C2_FS_SCL_LCNT_REG (0x50001520)

Bit	Mode	Symbol	Description	Reset
15:0	R/W	IC_FS_SCL_LCNT	<p>This register must be set before any I2C bus transaction can take place to ensure proper I/O timing. This register sets the SCL clock low-period count for fast speed. It is used in high-speed mode to send the Master Code and START BYTE or General CALL. This register can be written only when the I2C interface is disabled, which corresponds to the I2C_ENABLE register being set to 0. Writes at other times have no effect.</p> <p>The minimum valid value is 8; hardware prevents values less than this being written, and if attempted results in 8 being set. For designs with APB_DATA_WIDTH = 8 the order of programming is important to ensure the correct operation of the controller. The lower byte must be programmed first. Then the upper byte is programmed.</p>	0x17

Table 380: I2C2_INTR_STAT_REG (0x5000152C)

Bit	Mode	Symbol	Description	Reset
15:12	-	-	Reserved	0x0
11	R	R_GEN_CALL	Set only when a General Call address is received and it is acknowledged. It stays set until it is cleared either by disabling controller or when the CPU reads bit 0 of the I2C_CLR_GEN_CALL register. The controller stores the received data in the Rx buffer.	0x0
10	R	R_START_DET	Indicates whether a START or RESTART condition has occurred on the I2C interface regardless of whether controller is operating in slave or master mode.	0x0
9	R	R_STOP_DET	Indicates whether a STOP condition has occurred on the I2C interface regardless of whether controller is operating in slave or master mode.	0x0
8	R	R_ACTIVITY	<p>This bit captures I2C Ctrl activity and stays set until it is cleared. There are four ways to clear it:</p> <ul style="list-style-type: none"> => Disabling the I2C Ctrl => Reading the IC_CLR_ACTIVITY register => Reading the IC_CLR_INTR register => System reset <p>Once this bit is set, it stays set unless one of the four methods is used to clear it. Even if the controller module is idle, this bit remains set until cleared, indicating that there was activity on the bus.</p>	0x0
7	R	R_RX_DONE	When the controller is acting as a slave-transmitter, this bit is set to 1 if the master does not acknowledge a transmitted byte. This occurs on the last byte of the transmission, indicating that the transmission is done.	0x0

Table 380: I2C2_INTR_STAT_REG (0x5000152C)

Bit	Mode	Symbol	Description	Reset
6	R	R_TX_ABRT	<p>This bit indicates if the controller, as an I2C transmitter, is unable to complete the intended actions on the contents of the transmit FIFO. This situation can occur both as an I2C master or an I2C slave, and is referred to as a "transmit abort".</p> <p>When this bit is set to 1, the I2C_TX_ABRT_SOURCE register indicates the reason why the transmit abort takes places. NOTE: The controller flushes/resets/empties the TX FIFO whenever this bit is set. The TX FIFO remains in this flushed state until the register I2C_CLR_TX_ABRT is read. Once this read is performed, the TX FIFO is then ready to accept more data bytes from the APB interface.</p>	0x0
5	R	R_RD_REQ	<p>This bit is set to 1 when the controller is acting as a slave and another I2C master is attempting to read data from the controller. The controller holds the I2C bus in a wait state (SCL=0) until this interrupt is serviced, which means that the slave has been addressed by a remote master that is asking for data to be transferred. The processor must respond to this interrupt and then write the requested data to the I2C_DATA_CMD register. This bit is set to 0 just after the processor reads the I2C_CLR_RD_REQ register</p>	0x0
4	R	R_TX_EMPTY	<p>This bit is set to 1 when the transmit buffer is at or below the threshold value set in the I2C_TX_TL register. It is automatically cleared by hardware when the buffer level goes above the threshold. When the IC_ENABLE bit 0 is 0, the TX FIFO is flushed and held in reset. There the TX FIFO looks like it has no data within it, so this bit is set to 1, provided there is activity in the master or slave state machines. When there is no longer activity, then with ic_en=0, this bit is set to 0.</p>	0x0
3	R	R_TX_OVER	<p>Set during transmit if the transmit buffer is filled to 32 and the processor attempts to issue another I2C command by writing to the IC_DATA_CMD register. When the module is disabled, this bit keeps its level until the master or slave state machines go into idle, and when ic_en goes to 0, this interrupt is cleared</p>	0x0
2	R	R_RX_FULL	<p>Set when the receive buffer reaches or goes above the RX_TL threshold in the I2C_RX_TL register. It is automatically cleared by hardware when buffer level goes below the threshold. If the module is disabled (I2C_ENABLE[0]=0), the RX FIFO is flushed and held in reset; therefore the RX FIFO is not full. So this bit is cleared once the I2C_ENABLE bit 0 is programmed with a 0, regardless of the activity that continues.</p>	0x0
1	R	R_RX_OVER	<p>Set if the receive buffer is completely filled to 32 and an additional byte is received from an external I2C device. The controller acknowledges this, but any data bytes received after the FIFO is full are lost. If the module is disabled (I2C_ENABLE[0]=0), this bit keeps its level until the master or slave state machines go into idle, and when ic_en goes to 0, this interrupt is cleared.</p>	0x0
0	R	R_RX_UNDER	<p>Set if the processor attempts to read the receive buffer when it is empty by reading from the IC_DATA_CMD register. If the module is disabled (I2C_ENABLE[0]=0), this bit keeps its level until the master or slave state machines go into idle, and when ic_en goes to 0, this interrupt is cleared.</p>	0x0

Table 381: I2C2_INTR_MASK_REG (0x50001530)

Bit	Mode	Symbol	Description	Reset
15:12	-	-	Reserved	0x0
11	R/W	M_GEN_CALL	These bits mask their corresponding interrupt status bits in the I2C_INTR_STAT register.	0x1
10	R/W	M_START_DET	These bits mask their corresponding interrupt status bits in the I2C_INTR_STAT register.	0x0
9	R/W	M_STOP_DET	These bits mask their corresponding interrupt status bits in the I2C_INTR_STAT register.	0x0
8	R/W	M_ACTIVITY	These bits mask their corresponding interrupt status bits in the I2C_INTR_STAT register.	0x0
7	R/W	M_RX_DONE	These bits mask their corresponding interrupt status bits in the I2C_INTR_STAT register.	0x1
6	R/W	M_TX_ABRT	These bits mask their corresponding interrupt status bits in the I2C_INTR_STAT register.	0x1
5	R/W	M_RD_REQ	These bits mask their corresponding interrupt status bits in the I2C_INTR_STAT register.	0x1
4	R/W	M_TX_EMPTY	These bits mask their corresponding interrupt status bits in the I2C_INTR_STAT register.	0x1
3	R/W	M_TX_OVER	These bits mask their corresponding interrupt status bits in the I2C_INTR_STAT register.	0x1
2	R/W	M_RX_FULL	These bits mask their corresponding interrupt status bits in the I2C_INTR_STAT register.	0x1
1	R/W	M_RX_OVER	These bits mask their corresponding interrupt status bits in the I2C_INTR_STAT register.	0x1
0	R/W	M_RX_UNDER	These bits mask their corresponding interrupt status bits in the I2C_INTR_STAT register.	0x1

Table 382: I2C2_RAW_INTR_STAT_REG (0x50001534)

Bit	Mode	Symbol	Description	Reset
15:12	-	-	Reserved	0x0
11	R	GEN_CALL	Set only when a General Call address is received and it is acknowledged. It stays set until it is cleared either by disabling controller or when the CPU reads bit 0 of the I2C_CLR_GEN_CALL register. I2C Ctrl stores the received data in the Rx buffer.	0x0
10	R	START_DET	Indicates whether a START or RESTART condition has occurred on the I2C interface regardless of whether controller is operating in slave or master mode.	0x0
9	R	STOP_DET	Indicates whether a STOP condition has occurred on the I2C interface regardless of whether controller is operating in slave or master mode.	0x0
8	R	ACTIVITY	This bit captures I2C Ctrl activity and stays set until it is cleared. There are four ways to clear it: => Disabling the I2C Ctrl => Reading the IC_CLR_ACTIVITY register => Reading the IC_CLR_INTR register => System reset Once this bit is set, it stays set unless one of the four methods is used to clear it. Even if the controller module is idle, this bit remains set until cleared, indicating that there was activity on the bus.	0x0

Table 382: I2C2_RAW_INTR_STAT_REG (0x50001534)

Bit	Mode	Symbol	Description	Reset
7	R	RX_DONE	When the controller is acting as a slave-transmitter, this bit is set to 1 if the master does not acknowledge a transmitted byte. This occurs on the last byte of the transmission, indicating that the transmission is done.	0x0
6	R	TX_ABORT	This bit indicates if the controller, as an I2C transmitter, is unable to complete the intended actions on the contents of the transmit FIFO. This situation can occur both as an I2C master or an I2C slave, and is referred to as a "transmit abort". When this bit is set to 1, the I2C_TX_ABORT_SOURCE register indicates the reason why the transmit abort takes places. NOTE: The controller flushes/resets/empties the TX FIFO whenever this bit is set. The TX FIFO remains in this flushed state until the register I2C_CLR_TX_ABORT is read. Once this read is performed, the TX FIFO is then ready to accept more data bytes from the APB interface.	0x0
5	R	RD_REQ	This bit is set to 1 when I2C Ctrl is acting as a slave and another I2C master is attempting to read data from the controller. The controller holds the I2C bus in a wait state (SCL=0) until this interrupt is serviced, which means that the slave has been addressed by a remote master that is asking for data to be transferred. The processor must respond to this interrupt and then write the requested data to the I2C_DATA_CMD register. This bit is set to 0 just after the processor reads the I2C_CLR_RD_REQ register	0x0
4	R	TX_EMPTY	This bit is set to 1 when the transmit buffer is at or below the threshold value set in the I2C_TX_TL register. It is automatically cleared by hardware when the buffer level goes above the threshold. When the IC_ENABLE bit 0 is 0, the TX FIFO is flushed and held in reset. There the TX FIFO looks like it has no data within it, so this bit is set to 1, provided there is activity in the master or slave state machines. When there is no longer activity, then with ic_en=0, this bit is set to 0.	0x0
3	R	TX_OVER	Set during transmit if the transmit buffer is filled to 32 and the processor attempts to issue another I2C command by writing to the IC_DATA_CMD register. When the module is disabled, this bit keeps its level until the master or slave state machines go into idle, and when ic_en goes to 0, this interrupt is cleared	0x0
2	R	RX_FULL	Set when the receive buffer reaches or goes above the RX_TL threshold in the I2C_RX_TL register. It is automatically cleared by hardware when buffer level goes below the threshold. If the module is disabled (I2C_ENABLE[0]=0), the RX FIFO is flushed and held in reset; therefore the RX FIFO is not full. So this bit is cleared once the I2C_ENABLE bit 0 is programmed with a 0, regardless of the activity that continues.	0x0
1	R	RX_OVER	Set if the receive buffer is completely filled to 32 and an additional byte is received from an external I2C device. The controller acknowledges this, but any data bytes received after the FIFO is full are lost. If the module is disabled (I2C_ENABLE[0]=0), this bit keeps its level until the master or slave state machines go into idle, and when ic_en goes to 0, this interrupt is cleared.	0x0

Table 382: I2C2_RAW_INTR_STAT_REG (0x50001534)

Bit	Mode	Symbol	Description	Reset
0	R	RX_UNDER	Set if the processor attempts to read the receive buffer when it is empty by reading from the IC_DATA_CMD register. If the module is disabled (I2C_ENABLE[0]=0), this bit keeps its level until the master or slave state machines go into idle, and when ic_en goes to 0, this interrupt is cleared.	0x0

Table 383: I2C2_RX_TL_REG (0x50001538)

Bit	Mode	Symbol	Description	Reset
15:5	-	-	Reserved	0x0
4:0	R/W	RX_TL	Receive FIFO Threshold Level Controls the level of entries (or above) that triggers the RX_FULL interrupt (bit 2 in I2C_RAW_INTR_STAT register). The valid range is 0-31, with the additional restriction that hardware does not allow this value to be set to a value larger than the depth of the buffer. If an attempt is made to do that, the actual value set will be the maximum depth of the buffer. A value of 0 sets the threshold for 1 entry, and a value of 31 sets the threshold for 32 entries.	0x0

Table 384: I2C2_TX_TL_REG (0x5000153C)

Bit	Mode	Symbol	Description	Reset
15:5	-	-	Reserved	0x0
4:0	R/W	RX_TL	Transmit FIFO Threshold Level Controls the level of entries (or below) that trigger the TX_EMPTY interrupt (bit 4 in I2C_RAW_INTR_STAT register). The valid range is 0-31, with the additional restriction that it may not be set to value larger than the depth of the buffer. If an attempt is made to do that, the actual value set will be the maximum depth of the buffer. A value of 0 sets the threshold for 0 entries, and a value of 31 sets the threshold for 32 entries..	0x0

Table 385: I2C2_CLR_INTR_REG (0x50001540)

Bit	Mode	Symbol	Description	Reset
15:1	-	-	Reserved	0x0
0	R	CLR_INTR	Read this register to clear the combined interrupt, all individual interrupts, and the I2C_TX_ABRT_SOURCE register. This bit does not clear hardware clearable interrupts but software clearable interrupts. Refer to Bit 9 of the I2C_TX_ABRT_SOURCE register for an exception to clearing I2C_TX_ABRT_SOURCE	0x0

Table 386: I2C2_CLR_RX_UNDER_REG (0x50001544)

Bit	Mode	Symbol	Description	Reset
15:1	-	-	Reserved	0x0
0	R	CLR_RX_UNDER	Read this register to clear the RX_UNDER interrupt (bit 0) of the I2C_RAW_INTR_STAT register.	0x0

Table 387: I2C2_CLR_RX_OVER_REG (0x50001548)

Bit	Mode	Symbol	Description	Reset
15:1	-	-	Reserved	0x0
0	R	CLR_RX_OVER	Read this register to clear the RX_OVER interrupt (bit 1) of the I2C_RAW_INTR_STAT register.	0x0

Table 388: I2C2_CLR_TX_OVER_REG (0x5000154C)

Bit	Mode	Symbol	Description	Reset
15:1	-	-	Reserved	0x0
0	R	CLR_TX_OVER	Read this register to clear the TX_OVER interrupt (bit 3) of the I2C_RAW_INTR_STAT register.	0x0

Table 389: I2C2_CLR_RD_REQ_REG (0x50001550)

Bit	Mode	Symbol	Description	Reset
15:1	-	-	Reserved	0x0
0	R	CLR_RD_REQ	Read this register to clear the RD_REQ interrupt (bit 5) of the I2C_RAW_INTR_STAT register.	0x0

Table 390: I2C2_CLR_TX_ABRT_REG (0x50001554)

Bit	Mode	Symbol	Description	Reset
15:1	-	-	Reserved	0x0
0	R	CLR_TX_ABRT	Read this register to clear the TX_ABRT interrupt (bit 6) of the IC_RAW_INTR_STAT register, and the I2C_TX_ABRT_SOURCE register. This also releases the TX FIFO from the flushed/reset state, allowing more writes to the TX FIFO. Refer to Bit 9 of the I2C_TX_ABRT_SOURCE register for an exception to clearing IC_TX_ABRT_SOURCE.	0x0

Table 391: I2C2_CLR_RX_DONE_REG (0x50001558)

Bit	Mode	Symbol	Description	Reset
15:1	-	-	Reserved	0x0
0	R	CLR_RX_DONE	Read this register to clear the RX_DONE interrupt (bit 7) of the I2C_RAW_INTR_STAT register.	0x0

Table 392: I2C2_CLR_ACTIVITY_REG (0x5000155C)

Bit	Mode	Symbol	Description	Reset
15:1	-	-	Reserved	0x0
0	R	CLR_ACTIVITY	Reading this register clears the ACTIVITY interrupt if the I2C is not active anymore. If the I2C module is still active on the bus, the ACTIVITY interrupt bit continues to be set. It is automatically cleared by hardware if the module is disabled and if there is no further activity on the bus. The value read from this register to get status of the ACTIVITY interrupt (bit 8) of the IC_RAW_INTR_STAT register	0x0

Table 393: I2C2_CLR_STOP_DET_REG (0x50001560)

Bit	Mode	Symbol	Description	Reset
15:1	-	-	Reserved	0x0
0	R	CLR_ACTIVITY	Reading this register clears the ACTIVITY interrupt if the I2C is not active anymore. If the I2C module is still active on the bus, the ACTIVITY interrupt bit continues to be set. It is automatically cleared by hardware if the module is disabled and if there is no further activity on the bus. The value read from this register to get status of the ACTIVITY interrupt (bit 8) of the IC_RAW_INTR_STAT register.	0x0

Table 394: I2C2_CLR_START_DET_REG (0x50001564)

Bit	Mode	Symbol	Description	Reset
15:1	-	-	Reserved	0x0
0	R	CLR_START_DET	Read this register to clear the START_DET interrupt (bit 10) of the IC_RAW_INTR_STAT register.	0x0

Table 395: I2C2_CLR_GEN_CALL_REG (0x50001568)

Bit	Mode	Symbol	Description	Reset
15:1	-	-	Reserved	0x0
0	R	CLR_GEN_CALL	Read this register to clear the GEN_CALL interrupt (bit 11) of I2C_RAW_INTR_STAT register.	0x0

Table 396: I2C2_ENABLE_REG (0x5000156C)

Bit	Mode	Symbol	Description	Reset
15:1	-	-	Reserved	0x0
0	R/W	CTRL_ENABLE	<p>Controls whether the controller is enabled.</p> <p>0: Disables the controller (TX and RX FIFOs are held in an erased state)</p> <p>1: Enables the controller</p> <p>Software can disable the controller while it is active. However, it is important that care be taken to ensure that the controller is disabled properly. When the controller is disabled, the following occurs:</p> <ul style="list-style-type: none"> * The TX FIFO and RX FIFO get flushed. * Status bits in the IC_INTR_STAT register are still active until the controller goes into IDLE state. <p>If the module is transmitting, it stops as well as deletes the contents of the transmit buffer after the current transfer is complete. If the module is receiving, the controller stops the current transfer at the end of the current byte and does not acknowledge the transfer.</p> <p>There is a two ic_clk delay when enabling or disabling the controller</p>	0x0

Table 397: I2C2_STATUS_REG (0x50001570)

Bit	Mode	Symbol	Description	Reset
15:7	-	-	Reserved	0x0

Table 397: I2C2_STATUS_REG (0x50001570)

Bit	Mode	Symbol	Description	Reset
6	R	SLV_ACTIVITY	Slave FSM Activity Status. When the Slave Finite State Machine (FSM) is not in the IDLE state, this bit is set. 0: Slave FSM is in IDLE state so the Slave part of the controller is not Active 1: Slave FSM is not in IDLE state so the Slave part of the controller is Active	0x0
5	R	MST_ACTIVITY	Master FSM Activity Status. When the Master Finite State Machine (FSM) is not in the IDLE state, this bit is set. 0: Master FSM is in IDLE state so the Master part of the controller is not Active 1: Master FSM is not in IDLE state so the Master part of the controller is Active	0x0
4	R	RFF	Receive FIFO Completely Full. When the receive FIFO is completely full, this bit is set. When the receive FIFO contains one or more empty location, this bit is cleared. 0: Receive FIFO is not full 1: Receive FIFO is full	0x0
3	R	RFNE	Receive FIFO Not Empty. This bit is set when the receive FIFO contains one or more entries; it is cleared when the receive FIFO is empty. 0: Receive FIFO is empty 1: Receive FIFO is not empty	0x0
2	R	TFE	Transmit FIFO Completely Empty. When the transmit FIFO is completely empty, this bit is set. When it contains one or more valid entries, this bit is cleared. This bit field does not request an interrupt. 0: Transmit FIFO is not empty 1: Transmit FIFO is empty	0x1
1	R	TFNF	Transmit FIFO Not Full. Set when the transmit FIFO contains one or more empty locations, and is cleared when the FIFO is full. 0: Transmit FIFO is full 1: Transmit FIFO is not full	0x1
0	R	I2C_ACTIVITY	I2C Activity Status.	0x0

Table 398: I2C2_TXFLR_REG (0x50001574)

Bit	Mode	Symbol	Description	Reset
15:6	-	-	Reserved	0x0
5:0	R	TXFLR	Transmit FIFO Level. Contains the number of valid data entries in the transmit FIFO. Size is constrained by the TXFLR value	0x0

Table 399: I2C2_RXFLR_REG (0x50001578)

Bit	Mode	Symbol	Description	Reset
15:6	-	-	Reserved	0x0
5:0	R	RXFLR	Receive FIFO Level. Contains the number of valid data entries in the receive FIFO. Size is constrained by the RXFLR value	0x0

Table 400: I2C2_SDA_HOLD_REG (0x5000157C)

Bit	Mode	Symbol	Description	Reset
15:0	R/W	IC_SDA_HOLD	SDA Hold time	0x1

Table 401: I2C2_TX_ABRT_SOURCE_REG (0x50001580)

Bit	Mode	Symbol	Description	Reset
15	R	ABRT_SLVRD_INTX	1: When the processor side responds to a slave mode request for data to be transmitted to a remote master and user writes a 1 in CMD (bit 8) of I2C2_DATA_CMD register	0x0
14	R	ABRT_SLV_ARBLOST	1: Slave lost the bus while transmitting data to a remote master. I2C2_TX_ABRT_SOURCE[12] is set at the same time. Note: Even though the slave never "owns" the bus, something could go wrong on the bus. This is a fail safe check. For instance, during a data transmission at the low-to-high transition of SCL, if what is on the data bus is not what is supposed to be transmitted, then the controller no longer own the bus.	0x0
13	R	ABRT_SLVFLUSH_TXFIFO	1: Slave has received a read command and some data exists in the TX FIFO so the slave issues a TX_ABRT interrupt to flush old data in TX FIFO.	0x0
12	R	ARB_LOST	1: Master has lost arbitration, or if I2C2_TX_ABRT_SOURCE[14] is also set, then the slave transmitter has lost arbitration. Note: I2C can be both master and slave at the same time.	0x0
11	R	ABRT_MASTER_DIS	1: User tries to initiate a Master operation with the Master mode disabled.	0x0
10	R	ABRT_10B_RD_NORSTR	1: The restart is disabled (IC_RESTART_EN bit (I2C2_CON[5]) = 0) and the master sends a read command in 10-bit addressing mode.	0x0
9	R	ABRT_SBYTE_NORSTR	To clear Bit 9, the source of the ABRT_SBYTE_NORSTR must be fixed first; restart must be enabled (I2C2_CON[5]=1), the SPECIAL bit must be cleared (I2C2_TAR[11]), or the GC_OR_START bit must be cleared (I2C2_TAR[10]). Once the source of the ABRT_SBYTE_NORSTR is fixed, then this bit can be cleared in the same manner as other bits in this register. If the source of the ABRT_SBYTE_NORSTR is not fixed before attempting to clear this bit, bit 9 clears for one cycle and then gets re-asserted. 1: The restart is disabled (IC_RESTART_EN bit (I2C2_CON[5]) = 0) and the user is trying to send a START Byte.	0x0
8	R	ABRT_HS_NORSTR	1: The restart is disabled (IC_RESTART_EN bit (I2C2_CON[5]) = 0) and the user is trying to use the master to transfer data in High Speed mode	0x0
7	R	ABRT_SBYTE_ACKDET	1: Master has sent a START Byte and the START Byte was acknowledged (wrong behavior).	0x0
6	R	ABRT_HS_ACKDET	1: Master is in High Speed mode and the High Speed Master code was acknowledged (wrong behavior).	0x0
5	R	ABRT_GCALL_READ	1: the controller in master mode sent a General Call but the user programmed the byte following the General Call to be a read from the bus (IC_DATA_CMD[9] is set to 1).	0x0
4	R	ABRT_GCALL_NOACK	1: the controller in master mode sent a General Call and no slave on the bus acknowledged the General Call.	0x0

Table 401: I2C2_TX_ABORT_SOURCE_REG (0x50001580)

Bit	Mode	Symbol	Description	Reset
3	R	ABRT_TXDATA_NOACK	1: This is a master-mode only bit. Master has received an acknowledgement for the address, but when it sent data byte(s) following the address, it did not receive an acknowledgement from the remote slave(s).	0x0
2	R	ABRT_10ADDR2_NOACK	1: Master is in 10-bit address mode and the second address byte of the 10-bit address was not acknowledged by any slave.	0x0
1	R	ABRT_10ADDR1_NOACK	1: Master is in 10-bit address mode and the first 10-bit address byte was not acknowledged by any slave.	0x0
0	R	ABRT_7B_ADDR_NOACK	1: Master is in 7-bit addressing mode and the address sent was not acknowledged by any slave.	0x0

Table 402: I2C2_DMA_CR_REG (0x50001588)

Bit	Mode	Symbol	Description	Reset
1	R/W	TDMAE	Transmit DMA Enable. //This bit enables/disables the transmit FIFO DMA channel. 0 = Transmit DMA disabled 1 = Transmit DMA enabled	0x0
0	R/W	RDMAE	Receive DMA Enable. This bit enables/disables the receive FIFO DMA channel. 0 = Receive DMA disabled 1 = Receive DMA enabled	0x0

Table 403: I2C2_DMA_TDLR_REG (0x5000158C)

Bit	Mode	Symbol	Description	Reset
4:0	R/W	DMATDL	Transmit Data Level. This bit field controls the level at which a DMA request is made by the transmit logic. It is equal to the watermark level; that is, the dma_tx_req signal is generated when the number of valid data entries in the transmit FIFO is equal to or below this field value, and TDMAE = 1.	0x0

Table 404: I2C2_DMA_RDLR_REG (0x50001590)

Bit	Mode	Symbol	Description	Reset
4:0	R/W	DMARDL	Receive Data Level. This bit field controls the level at which a DMA request is made by the receive logic. The watermark level = DMARDL+1; that is, dma_rx_req is generated when the number of valid data entries in the receive FIFO is equal to or more than this field value + 1, and RDMAE = 1. For instance, when DMARDL is 0, then dma_rx_req is asserted when 1 or more data entries are present in the receive FIFO.	0x0

Table 405: I2C2_SDA_SETUP_REG (0x50001594)

Bit	Mode	Symbol	Description	Reset
15:8	-	-	Reserved	0x0

Table 405: I2C2_SDA_SETUP_REG (0x50001594)

Bit	Mode	Symbol	Description	Reset
7:0	R/W	SDA_SETUP	<p>SDA Setup.</p> <p>This register controls the amount of time delay (number of I2C clock periods) between the rising edge of SCL and SDA changing by holding SCL low when I2C block services a read request while operating as a slave-transmitter. The relevant I2C requirement is tSU:DAT (note 4) as detailed in the I2C Bus Specification. This register must be programmed with a value equal to or greater than 2.</p> <p>It is recommended that if the required delay is 1000ns, then for an I2C frequency of 10 MHz, IC_SDA_SETUP should be programmed to a value of 11. Writes to this register succeed only when IC_ENABLE[0] = 0.</p>	0x64

Table 406: I2C2_ACK_GENERAL_CALL_REG (0x50001598)

Bit	Mode	Symbol	Description	Reset
15:1	-	-	Reserved	0x0
0	R/W	ACK_GEN_CALL	ACK General Call. When set to 1, I2C Ctrl responds with a ACK (by asserting ic_data_oe) when it receives a General Call. When set to 0, the controller does not generate General Call interrupts.	0x0

Table 407: I2C2_ENABLE_STATUS_REG (0x5000159C)

Bit	Mode	Symbol	Description	Reset
15:3	-	-	Reserved	0x0
2	R	SLV_RX_DATA_LOST	<p>Slave Received Data Lost. This bit indicates if a Slave-Receiver operation has been aborted with at least one data byte received from an I2C transfer due to the setting of IC_ENABLE from 1 to 0. When read as 1, the controller is deemed to have been actively engaged in an aborted I2C transfer (with matching address) and the data phase of the I2C transfer has been entered, even though a data byte has been responded with a NACK. NOTE: If the remote I2C master terminates the transfer with a STOP condition before the controller has a chance to NACK a transfer, and IC_ENABLE has been set to 0, then this bit is also set to 1.</p> <p>When read as 0, the controller is deemed to have been disabled without being actively involved in the data phase of a Slave-Receiver transfer.</p> <p>NOTE: The CPU can safely read this bit when IC_EN (bit 0) is read as 0.</p>	0x0

Table 407: I2C2_ENABLE_STATUS_REG (0x5000159C)

Bit	Mode	Symbol	Description	Reset
1	R	SLV_DISABLED_WHILE_BUSY	<p>Slave Disabled While Busy (Transmit, Receive). This bit indicates if a potential or active Slave operation has been aborted due to the setting of the IC_ENABLE register from 1 to 0. This bit is set when the CPU writes a 0 to the IC_ENABLE register while:</p> <p>(a) I2C Ctrl is receiving the address byte of the Slave-Transmitter operation from a remote master; OR,</p> <p>(b) address and data bytes of the Slave-Receiver operation from a remote master. When read as 1, the controller is deemed to have forced a NACK during any part of an I2C transfer, irrespective of whether the I2C address matches the slave address set in I2C Ctrl (IC_SAR register) OR if the transfer is completed before IC_ENABLE is set to 0 but has not taken effect.</p> <p>NOTE: If the remote I2C master terminates the transfer with a STOP condition before the the controller has a chance to NACK a transfer, and IC_ENABLE has been set to 0, then this bit will also be set to 1.</p> <p>When read as 0, the controller is deemed to have been disabled when there is master activity, or when the I2C bus is idle.</p> <p>NOTE: The CPU can safely read this bit when IC_EN (bit 0) is read as 0.</p>	0x0
0	R	IC_EN	<p>ic_en Status. This bit always reflects the value driven on the output port ic_en. When read as 1, the controller is deemed to be in an enabled state.</p> <p>When read as 0, the controller is deemed completely inactive.</p> <p>NOTE: The CPU can safely read this bit anytime. When this bit is read as 0, the CPU can safely read SLV_RX_DATA_LOST (bit 2) and SLV_DISABLED_WHILE_BUSY (bit 1).</p>	0x0

Table 408: I2C2_IC_FS_SPKLEN_REG (0x500015A0)

Bit	Mode	Symbol	Description	Reset
15:8	-	-	Reserved	0x0
7:0	R/W	IC_FS_SPKLEN	<p>This register must be set before any I2C bus transaction can take place to ensure stable operation. This register sets the duration, measured in ic_clk cycles, of the longest spike in the SCL or SDA lines that will be filtered out by the spike suppression logic. This register can be written only when the I2C interface is disabled which corresponds to the IC_ENABLE register being set to 0. Writes at other times have no effect. The minimum valid value is 2; hardware prevents values less than this being written, and if attempted results in 2 being set.</p>	0x1

Table 409: I2C2_COMP_PARAM1_REG (0x500015F4)

Bit	Mode	Symbol	Description	Reset
-	-	-	Undefined	-

Table 410: I2C2_COMP_PARAM2_REG (0x500015F6)

Bit	Mode	Symbol	Description	Reset
-	-	-	Undefined	-

Table 411: I2C2_COMP_VERSION_REG (0x500015F8)

Bit	Mode	Symbol	Description	Reset
-	-	-	Undefined	-

Table 412: I2C2_COMP2_VERSION (0x500015FA)

Bit	Mode	Symbol	Description	Reset
-	-	-	Undefined	-

Table 413: I2C2_COMP_TYPE_REG (0x500015FC)

Bit	Mode	Symbol	Description	Reset
-	-	-	Undefined	-

Table 414: I2C2_COMP_TYPE2_REG (0x500015FE)

Bit	Mode	Symbol	Description	Reset
-	-	-	Undefined	-

37.13 KEYBOARD SCAN REGISTER FILE

Table 415: Register map KEYBOARD SCAN

Address	Port	Description
0x50001600	KBSCN_CTRL_REG	Keyboard scanner control register
0x50001602	KBSCN_CTRL2_REG	Keyboard scanner control 2 register
0x50001604	KBSCN_MATRIX_SIZE_REG	Defines the number of rows and columns of the matrix
0x50001606	KBSCN_DEBOUNCE_REG	Defines the debounce time for key press and release
0x50001608	KBSCN_STATUS_REG	keyboard scanner Interrupt status register
0x5000160A	KBSCN_MESSAGE_KEY_REG	Returns a key message from the message queue
0x5000160C	KBSCN_P00_MODE_REG	Defines the keyboard mode for P00
0x5000160E	KBSCN_P01_MODE_REG	Defines the keyboard mode for P01
0x50001610	KBSCN_P02_MODE_REG	Defines the keyboard mode for P02
0x50001612	KBSCN_P03_MODE_REG	Defines the keyboard mode for P03
0x50001614	KBSCN_P04_MODE_REG	Defines the keyboard mode for P04
0x50001616	KBSCN_P05_MODE_REG	Defines the keyboard mode for P05
0x50001618	KBSCN_P06_MODE_REG	Defines the keyboard mode for P06
0x5000161A	KBSCN_P07_MODE_REG	Defines the keyboard mode for P07
0x5000161C	KBSCN_P10_MODE_REG	Defines the keyboard mode for P10
0x5000161E	KBSCN_P11_MODE_REG	Defines the keyboard mode for P11
0x50001620	KBSCN_P12_MODE_REG	Defines the keyboard mode for P12
0x50001622	KBSCN_P13_MODE_REG	Defines the keyboard mode for P13
0x50001624	KBSCN_P14_MODE_REG	Defines the keyboard mode for P14
0x50001626	KBSCN_P15_MODE_REG	Defines the keyboard mode for P15
0x50001628	KBSCN_P16_MODE_REG	Defines the keyboard mode for P16
0x5000162A	KBSCN_P17_MODE_REG	Defines the keyboard mode for P17
0x5000162C	KBSCN_P20_MODE_REG	Defines the keyboard mode for P20
0x5000162E	KBSCN_P21_MODE_REG	Defines the keyboard mode for P21
0x50001630	KBSCN_P22_MODE_REG	Defines the keyboard mode for P22
0x50001632	KBSCN_P23_MODE_REG	Defines the keyboard mode for P23
0x50001634	KBSCN_P24_MODE_REG	Defines the keyboard mode for P24
0x5000163C	KBSCN_P30_MODE_REG	Defines the keyboard mode for P30
0x5000163E	KBSCN_P31_MODE_REG	Defines the keyboard mode for P31
0x50001640	KBSCN_P32_MODE_REG	Defines the keyboard mode for P32
0x50001642	KBSCN_P33_MODE_REG	Defines the keyboard mode for P33
0x50001644	KBSCN_P34_MODE_REG	Defines the keyboard mode for P34
0x50001646	KBSCN_P35_MODE_REG	Defines the keyboard mode for P35
0x50001648	KBSCN_P36_MODE_REG	Defines the keyboard mode for P36
0x5000164A	KBSCN_P37_MODE_REG	Defines the keyboard mode for P37
0x5000164C	KBSCN_P40_MODE_REG	Defines the keyboard mode for P40
0x5000164E	KBSCN_P41_MODE_REG	Defines the keyboard mode for P41
0x50001650	KBSCN_P42_MODE_REG	Defines the keyboard mode for P42
0x50001652	KBSCN_P43_MODE_REG	Defines the keyboard mode for P43
0x50001654	KBSCN_P44_MODE_REG	Defines the keyboard mode for P44
0x50001656	KBSCN_P45_MODE_REG	Defines the keyboard mode for P45
0x50001658	KBSCN_P46_MODE_REG	Defines the keyboard mode for P46
0x5000165A	KBSCN_P47_MODE_REG	Defines the keyboard mode for P47

Table 416: KBSCN_CTRL_REG (0x50001600)

Bit	Mode	Symbol	Description	Reset
14	R0/W	KBSCN_RESET_FIFO	'1' reset fifo, read always '0'	0x0
13:12	R/W	KBSCN_CLKDIV	Defines keyboard clk. "00" div/1, "01" div/4, "10" div/16, "11" div/64	0x0
11	R/W	KBSCN_INACTIVE_EN	'1' After inactive time the keyboard scanner stops the key matrix scan	0x0
10:4	R/W	KBSCN_INACTIVE_TIME	Defines the inactive time in scan cycles. Value 0 is not allowed	0x0
3	R/W	KBSCN_IRQ_FIFO_MASK	'1' Enable IRQ for fifo over and under flow	0x0
2	R/W	KBSCN_IRQ_INACTIVE_MASK	'1' : Enable IRQ for inactive	0x0
1	R/W	KBSCN_IRQ_MESSAGE_MASK	'1' : Enable IRQ for message	0x0
0	R/W	KBSCN_EN	'1' : Enable keyboard scanner, Auto clear when inactive enable and inactive case	0x0

Table 417: KBSCN_CTRL2_REG (0x50001602)

Bit	Mode	Symbol	Description	Reset
15:0	R/W	KBSCN_ROW_ACTIVE_TIME	Define the row active time in keyboard clock cycles	0x0

Table 418: KBSCN_MATRIX_SIZE_REG (0x50001604)

Bit	Mode	Symbol	Description	Reset
8:4	R/W	KBSCN_MATRIX_COLUMNS	Defines the number of the columns of the keyboard matrix minus 1. Zero means number of columns 1	0x0
3:0	R/W	KBSCN_MATRIX_ROWS	Defines the number of the rows of the keyboard matrix minus 1. Zero means number of rows 1	0x0

Table 419: KBSCN_DEBOUNCE_REG (0x50001606)

Bit	Mode	Symbol	Description	Reset
11:6	R/W	KBSCN_DEBOUNCE_PRESS_TIME	Defines the press debounce time in cycles of full matrix scan. One means no debounce, zero is reserved	0x2
5:0	R/W	KBSCN_DEBOUNCE_RELEASE_TIME	Defines the press debounce time in cycles of full matrix scan. One means no debounce, zero is reserved	0x2

Table 420: KBSCN_STATUS_REG (0x50001608)

Bit	Mode	Symbol	Description	Reset
8	R	KBSCN_FIFO_UNDERFLOW	'1' Fifo Underflow occurred	0x0
7	R	KBSCN_FIFO_OVERFLOW	'1' Fifo Overflow occurred	0x0
6:2	R	KBSCN_NUM_MESSAGES	Defines how many messages there are in the fifo.	0x0
1	R	KBSCN_INACTIVE_IRQ_STATUS	There is no keyboard activity for a predefined time	0x0

Table 420: KBSCN_STATUS_REG (0x50001608)

Bit	Mode	Symbol	Description	Reset
0	R	KBSCN_MES_IRQ_STATUS	There is at least one last message in the fifo.	0x0

Table 421: KBSCN_MESSAGE_KEY_REG (0x5000160A)

Bit	Mode	Symbol	Description	Reset
10	R	KBSCN_LAST_ENTRY	'1' : this message is the last of the group message, else '0'. When '1' bits 9:0 are all '1'	0x0
9	R	KBSCN_KEY_STATE	'0' : New key state is release '1' : New key state is press	0x0
8:4	R	KBSCN_KEYID_COLUMN	Defines the column id of key	0x0
3:0	R	KBSCN_KEYID_ROW	Defines the row id of key	0x0

Table 422: KBSCN_P00_MODE_REG (0x5000160C)

Bit	Mode	Symbol	Description	Reset
6	R/W	KBSCN_GPIO_EN	'1' GPIO is enable for row or column	0x0
5	R/W	KBSCN_ROW	'1' GPIO is row, '0' GPIO is column	0x0
4:0	R/W	KBSCN_MODE	Defines the row/column index that has to be connected	0x0

Table 423: KBSCN_P01_MODE_REG (0x5000160E)

Bit	Mode	Symbol	Description	Reset
6	R/W	KBSCN_GPIO_EN	'1' GPIO is enable for row or column	0x0
5	R/W	KBSCN_ROW	'1' GPIO is row, '0' GPIO is column	0x0
4:0	R/W	KBSCN_MODE	Defines the row/column index that has to be connected	0x0

Table 424: KBSCN_P02_MODE_REG (0x50001610)

Bit	Mode	Symbol	Description	Reset
6	R/W	KBSCN_GPIO_EN	'1' GPIO is enable for row or column	0x0
5	R/W	KBSCN_ROW	'1' GPIO is row, '0' GPIO is column	0x0
4:0	R/W	KBSCN_MODE	Defines the row/column index that has to be connected	0x0

Table 425: KBSCN_P03_MODE_REG (0x50001612)

Bit	Mode	Symbol	Description	Reset
6	R/W	KBSCN_GPIO_EN	'1' GPIO is enable for row or column	0x0
5	R/W	KBSCN_ROW	'1' GPIO is row, '0' GPIO is column	0x0
4:0	R/W	KBSCN_MODE	Defines the row/column index that has to be connected	0x0

Table 426: KBSCN_P04_MODE_REG (0x50001614)

Bit	Mode	Symbol	Description	Reset
6	R/W	KBSCN_GPIO_EN	'1' GPIO is enable for row or column	0x0
5	R/W	KBSCN_ROW	'1' GPIO is row, '0' GPIO is column	0x0

Table 426: KBSCN_P04_MODE_REG (0x50001614)

Bit	Mode	Symbol	Description	Reset
4:0	R/W	KBSCN_MODE	Defines the row/column index that has to be connected	0x0

Table 427: KBSCN_P05_MODE_REG (0x50001616)

Bit	Mode	Symbol	Description	Reset
6	R/W	KBSCN_GPIO_EN	'1' GPIO is enable for row or column	0x0
5	R/W	KBSCN_ROW	'1' GPIO is row, '0' GPIO is column	0x0
4:0	R/W	KBSCN_MODE	Defines the row/column index that has to be connected	0x0

Table 428: KBSCN_P06_MODE_REG (0x50001618)

Bit	Mode	Symbol	Description	Reset
6	R/W	KBSCN_GPIO_EN	'1' GPIO is enable for row or column	0x0
5	R/W	KBSCN_ROW	'1' GPIO is row, '0' GPIO is column	0x0
4:0	R/W	KBSCN_MODE	Defines the row/column index that has to be connected	0x0

Table 429: KBSCN_P07_MODE_REG (0x5000161A)

Bit	Mode	Symbol	Description	Reset
6	R/W	KBSCN_GPIO_EN	'1' GPIO is enable for row or column	0x0
5	R/W	KBSCN_ROW	'1' GPIO is row, '0' GPIO is column	0x0
4:0	R/W	KBSCN_MODE	Defines the row/column index that has to be connected	0x0

Table 430: KBSCN_P10_MODE_REG (0x5000161C)

Bit	Mode	Symbol	Description	Reset
6	R/W	KBSCN_GPIO_EN	'1' GPIO is enable for row or column	0x0
5	R/W	KBSCN_ROW	'1' GPIO is row, '0' GPIO is column	0x0
4:0	R/W	KBSCN_MODE	Defines the row/column index that has to be connected	0x0

Table 431: KBSCN_P11_MODE_REG (0x5000161E)

Bit	Mode	Symbol	Description	Reset
6	R/W	KBSCN_GPIO_EN	'1' GPIO is enable for row or column	0x0
5	R/W	KBSCN_ROW	'1' GPIO is row, '0' GPIO is column	0x0
4:0	R/W	KBSCN_MODE	Defines the row/column index that has to be connected	0x0

Table 432: KBSCN_P12_MODE_REG (0x50001620)

Bit	Mode	Symbol	Description	Reset
6	R/W	KBSCN_GPIO_EN	'1' GPIO is enable for row or column	0x0
5	R/W	KBSCN_ROW	'1' GPIO is row, '0' GPIO is column	0x0
4:0	R/W	KBSCN_MODE	Defines the row/column index that has to be connected	0x0

Table 433: KBSCN_P13_MODE_REG (0x50001622)

Bit	Mode	Symbol	Description	Reset
6	R/W	KBSCN_GPIO_EN	'1' GPIO is enable for row or column	0x0
5	R/W	KBSCN_ROW	'1' GPIO is row, '0' GPIO is column	0x0
4:0	R/W	KBSCN_MODE	Defines the row/column index that has to be connected	0x0

Table 434: KBSCN_P14_MODE_REG (0x50001624)

Bit	Mode	Symbol	Description	Reset
6	R/W	KBSCN_GPIO_EN	'1' GPIO is enable for row or column	0x0
5	R/W	KBSCN_ROW	'1' GPIO is row, '0' GPIO is column	0x0
4:0	R/W	KBSCN_MODE	Defines the row/column index that has to be connected	0x0

Table 435: KBSCN_P15_MODE_REG (0x50001626)

Bit	Mode	Symbol	Description	Reset
6	R/W	KBSCN_GPIO_EN	'1' GPIO is enable for row or column	0x0
5	R/W	KBSCN_ROW	'1' GPIO is row, '0' GPIO is column	0x0
4:0	R/W	KBSCN_MODE	Defines the row/column index that has to be connected	0x0

Table 436: KBSCN_P16_MODE_REG (0x50001628)

Bit	Mode	Symbol	Description	Reset
6	R/W	KBSCN_GPIO_EN	'1' GPIO is enable for row or column	0x0
5	R/W	KBSCN_ROW	'1' GPIO is row, '0' GPIO is column	0x0
4:0	R/W	KBSCN_MODE	Defines the row/column index that has to be connected	0x0

Table 437: KBSCN_P17_MODE_REG (0x5000162A)

Bit	Mode	Symbol	Description	Reset
6	R/W	KBSCN_GPIO_EN	'1' GPIO is enable for row or column	0x0
5	R/W	KBSCN_ROW	'1' GPIO is row, '0' GPIO is column	0x0
4:0	R/W	KBSCN_MODE	Defines the row/column index that has to be connected	0x0

Table 438: KBSCN_P20_MODE_REG (0x5000162C)

Bit	Mode	Symbol	Description	Reset
6	R/W	KBSCN_GPIO_EN	'1' GPIO is enable for row or column	0x0
5	R/W	KBSCN_ROW	'1' GPIO is row, '0' GPIO is column	0x0
4:0	R/W	KBSCN_MODE	Defines the row/column index that has to be connected	0x0

Table 439: KBSCN_P21_MODE_REG (0x5000162E)

Bit	Mode	Symbol	Description	Reset
6	R/W	KBSCN_GPIO_EN	'1' GPIO is enable for row or column	0x0
5	R/W	KBSCN_ROW	'1' GPIO is row, '0' GPIO is column	0x0
4:0	R/W	KBSCN_MODE	Defines the row/column index that has to be connected	0x0

Table 440: KBSCN_P22_MODE_REG (0x50001630)

Bit	Mode	Symbol	Description	Reset
6	R/W	KBSCN_GPIO_EN	'1' GPIO is enable for row or column	0x0
5	R/W	KBSCN_ROW	'1' GPIO is row, '0' GPIO is column	0x0
4:0	R/W	KBSCN_MODE	Defines the row/column index that has to be connected	0x0

Table 441: KBSCN_P23_MODE_REG (0x50001632)

Bit	Mode	Symbol	Description	Reset
6	R/W	KBSCN_GPIO_EN	'1' GPIO is enable for row or column	0x0
5	R/W	KBSCN_ROW	'1' GPIO is row, '0' GPIO is column	0x0
4:0	R/W	KBSCN_MODE	Defines the row/column index that has to be connected	0x0

Table 442: KBSCN_P24_MODE_REG (0x50001634)

Bit	Mode	Symbol	Description	Reset
6	R/W	KBSCN_GPIO_EN	'1' GPIO is enable for row or column	0x0
5	R/W	KBSCN_ROW	'1' GPIO is row, '0' GPIO is column	0x0
4:0	R/W	KBSCN_MODE	Defines the row/column index that has to be connected	0x0

Table 443: KBSCN_P30_MODE_REG (0x5000163C)

Bit	Mode	Symbol	Description	Reset
6	R/W	KBSCN_GPIO_EN	'1' GPIO is enable for row or column	0x0
5	R/W	KBSCN_ROW	'1' GPIO is row, '0' GPIO is column	0x0
4:0	R/W	KBSCN_MODE	Defines the row/column index that has to be connected	0x0

Table 444: KBSCN_P31_MODE_REG (0x5000163E)

Bit	Mode	Symbol	Description	Reset
6	R/W	KBSCN_GPIO_EN	'1' GPIO is enable for row or column	0x0
5	R/W	KBSCN_ROW	'1' GPIO is row, '0' GPIO is column	0x0
4:0	R/W	KBSCN_MODE	Defines the row/column index that has to be connected	0x0

Table 445: KBSCN_P32_MODE_REG (0x50001640)

Bit	Mode	Symbol	Description	Reset
6	R/W	KBSCN_GPIO_EN	'1' GPIO is enable for row or column	0x0
5	R/W	KBSCN_ROW	'1' GPIO is row, '0' GPIO is column	0x0
4:0	R/W	KBSCN_MODE	Defines the row/column index that has to be connected	0x0

Table 446: KBSCN_P33_MODE_REG (0x50001642)

Bit	Mode	Symbol	Description	Reset
6	R/W	KBSCN_GPIO_EN	'1' GPIO is enable for row or column	0x0
5	R/W	KBSCN_ROW	'1' GPIO is row, '0' GPIO is column	0x0
4:0	R/W	KBSCN_MODE	Defines the row/column index that has to be connected	0x0

Table 447: KBSCN_P34_MODE_REG (0x50001644)

Bit	Mode	Symbol	Description	Reset
6	R/W	KBSCN_GPIO_EN	'1' GPIO is enable for row or column	0x0
5	R/W	KBSCN_ROW	'1' GPIO is row, '0' GPIO is column	0x0
4:0	R/W	KBSCN_MODE	Defines the row/column index that has to be connected	0x0

Table 448: KBSCN_P35_MODE_REG (0x50001646)

Bit	Mode	Symbol	Description	Reset
6	R/W	KBSCN_GPIO_EN	'1' GPIO is enable for row or column	0x0
5	R/W	KBSCN_ROW	'1' GPIO is row, '0' GPIO is column	0x0
4:0	R/W	KBSCN_MODE	Defines the row/column index that has to be connected	0x0

Table 449: KBSCN_P36_MODE_REG (0x50001648)

Bit	Mode	Symbol	Description	Reset
6	R/W	KBSCN_GPIO_EN	'1' GPIO is enable for row or column	0x0
5	R/W	KBSCN_ROW	'1' GPIO is row, '0' GPIO is column	0x0
4:0	R/W	KBSCN_MODE	Defines the row/column index that has to be connected	0x0

Table 450: KBSCN_P37_MODE_REG (0x5000164A)

Bit	Mode	Symbol	Description	Reset
6	R/W	KBSCN_GPIO_EN	'1' GPIO is enable for row or column	0x0
5	R/W	KBSCN_ROW	'1' GPIO is row, '0' GPIO is column	0x0
4:0	R/W	KBSCN_MODE	Defines the row/column index that has to be connected	0x0

Table 451: KBSCN_P40_MODE_REG (0x5000164C)

Bit	Mode	Symbol	Description	Reset
6	R/W	KBSCN_GPIO_EN	'1' GPIO is enable for row or column	0x0
5	R/W	KBSCN_ROW	'1' GPIO is row, '0' GPIO is column	0x0
4:0	R/W	KBSCN_MODE	Defines the row/column index that has to be connected	0x0

Table 452: KBSCN_P41_MODE_REG (0x5000164E)

Bit	Mode	Symbol	Description	Reset
6	R/W	KBSCN_GPIO_EN	'1' GPIO is enable for row or column	0x0
5	R/W	KBSCN_ROW	'1' GPIO is row, '0' GPIO is column	0x0
4:0	R/W	KBSCN_MODE	Defines the row/column index that has to be connected	0x0

Table 453: KBSCN_P42_MODE_REG (0x50001650)

Bit	Mode	Symbol	Description	Reset
6	R/W	KBSCN_GPIO_EN	'1' GPIO is enable for row or column	0x0
5	R/W	KBSCN_ROW	'1' GPIO is row, '0' GPIO is column	0x0
4:0	R/W	KBSCN_MODE	Defines the row/column index that has to be connected	0x0

Table 454: KBSCN_P43_MODE_REG (0x50001652)

Bit	Mode	Symbol	Description	Reset
6	R/W	KBSCN_GPIO_EN	'1' GPIO is enable for row or column	0x0
5	R/W	KBSCN_ROW	'1' GPIO is row, '0' GPIO is column	0x0
4:0	R/W	KBSCN_MODE	Defines the row/column index that has to be connected	0x0

Table 455: KBSCN_P44_MODE_REG (0x50001654)

Bit	Mode	Symbol	Description	Reset
6	R/W	KBSCN_GPIO_EN	'1' GPIO is enable for row or column	0x0
5	R/W	KBSCN_ROW	'1' GPIO is row, '0' GPIO is column	0x0
4:0	R/W	KBSCN_MODE	Defines the row/column index that has to be connected	0x0

Table 456: KBSCN_P45_MODE_REG (0x50001656)

Bit	Mode	Symbol	Description	Reset
6	R/W	KBSCN_GPIO_EN	'1' GPIO is enable for row or column	0x0
5	R/W	KBSCN_ROW	'1' GPIO is row, '0' GPIO is column	0x0
4:0	R/W	KBSCN_MODE	Defines the row/column index that has to be connected	0x0

Table 457: KBSCN_P46_MODE_REG (0x50001658)

Bit	Mode	Symbol	Description	Reset
6	R/W	KBSCN_GPIO_EN	'1' GPIO is enable for row or column	0x0
5	R/W	KBSCN_ROW	'1' GPIO is row, '0' GPIO is column	0x0
4:0	R/W	KBSCN_MODE	Defines the row/column index that has to be connected	0x0

Table 458: KBSCN_P47_MODE_REG (0x5000165A)

Bit	Mode	Symbol	Description	Reset
6	R/W	KBSCN_GPIO_EN	'1' GPIO is enable for row or column	0x0
5	R/W	KBSCN_ROW	'1' GPIO is row, '0' GPIO is column	0x0
4:0	R/W	KBSCN_MODE	Defines the row/column index that has to be connected	0x0

37.14 IR REGISTER FILE

Table 459: Register map IR

Address	Port	Description
0x50001700	IR_FREQ_CARRIER_ON_REG	Defines the carrier signal high duration
0x50001702	IR_FREQ_CARRIER_OFF_REG	Defines the carrier signal low duration
0x50001704	IR_LOGIC_ONE_TIME_REG	Defines the logic one waveform
0x50001706	IR_LOGIC_ZERO_TIME_REG	Defines the logic zero waveform
0x50001708	IR_CTRL_REG	IR control register
0x5000170A	IR_STATUS_REG	IR status register
0x5000170C	IR_REPEAT_TIME_REG	Defines the repeat time
0x5000170E	IR_MAIN_FIFO_REG	Main fifo write register
0x50001710	IR_REPEAT_FIFO_REG	Repeat fifo write register
0x50001712	IR_IRQ_STATUS_REG	IR interrupt status register

Table 460: IR_FREQ_CARRIER_ON_REG (0x50001700)

Bit	Mode	Symbol	Description	Reset
9:0	R/W	IR_FREQ_CARRIER_ON	Defines the carrier signal high duration in IR_clk cycles. 0x0 is not allowed as a value.	0x1

Table 461: IR_FREQ_CARRIER_OFF_REG (0x50001702)

Bit	Mode	Symbol	Description	Reset
9:0	R/W	IR_FREQ_CARRIER_OFF	Defines the carrier signal low duration in IR_clk cycles	0x1

Table 462: IR_LOGIC_ONE_TIME_REG (0x50001704)

Bit	Mode	Symbol	Description	Reset
15:8	R/W	IR_LOGIC_ONE_MARK	Defines the mark duration in carrier clock cycles. Must be >0	0x1
7:0	R/W	IR_LOGIC_ONE_SPACE	Defines the space duration in carrier clock cycles. Must be >0	0x1

Table 463: IR_LOGIC_ZERO_TIME_REG (0x50001706)

Bit	Mode	Symbol	Description	Reset
15:8	R/W	IR_LOGIC_ZERO_MARK	Defines the mark duration in carrier clock cycles. Must be >0	0x1
7:0	R/W	IR_LOGIC_ZERO_SPACE	Defines the space duration in carrier clock cycles. Must be >0	0x1

Table 464: IR_CTRL_REG (0x50001708)

Bit	Mode	Symbol	Description	Reset
8	R/W	IR_IRQ_EN	1 = Enables the interrupt generation upon TX completion 0 = masks out the interrupt generation upon TX completion	0x0
7	R/W	IR_LOGIC_ONE_FORMAT	1 = Logic one starts with a Space followed by a Mark 0 = Logic one starts with a Mark followed by a Space	0x0

Table 464: IR_CTRL_REG (0x50001708)

Bit	Mode	Symbol	Description	Reset
6	R/W	IR_LOGIC_ZERO_FORMAT	1 = Logic zero starts with a Space followed by a Mark 0 = Logic zero starts with a Mark followed by a Space	0x0
5	R/W	IR_INVERT_OUTPUT	1 = IR output is inverted 0 = IR output is not inverted	0x0
4	R/W	IR_REPEAT_TYPE	1 = repeat command is defined at Repeat FIFO 0 = repeat command is defined at Code FIFO	0x0
3	R/W	IR_TX_START	1 = IR transmits a command 0 = IR is stopped While this bit is 1 and SW programs it to 0, the code FIFO will be flushed automatically.	0x0
2	R/W	IR_ENABLE	1 = IR block is enabled 0 = IR block is disabled and at reset state. This also resets the pointers at the FIFOs	0x0
1	R0/W	IR_REP_FIFO_RESET	1 = Flush Repeat FIFO (auto clear)	0x0
0	R0/W	IR_CODE_FIFO_RESET	1 = Flush Code FIFO (auto clear)	0x0

Table 465: IR_STATUS_REG (0x5000170A)

Bit	Mode	Symbol	Description	Reset
10	R	IR_BUSY	1 = IR generator is busy sending a message 0 = IR generator is idle	0x0
9:6	R	IR_REP_FIFO_WORDS	Contains the amount of words in Repeat FIFO (updated only on write)	0x0
5:0	R	IR_CODE_FIFO_WORDS	Contains the amount of words in Code FIFO (updated only on write)	0x0

Table 466: IR_REPEAT_TIME_REG (0x5000170C)

Bit	Mode	Symbol	Description	Reset
15:0	R/W	IR_REPEAT_TIME	Defines the repeat time in carrier clock cycles. The repeat timer will start counting from the start of the command and will trigger the output of the same command residing in the Code FIFO or the special command residing in the Repeat FIFO as soon as it expires.	0x0

Table 467: IR_MAIN_FIFO_REG (0x5000170E)

Bit	Mode	Symbol	Description	Reset
15:0	R0/W	IR_CODE_FIFO_DATA	Code FIFO data write port	0x0

Table 468: IR_REPEAT_FIFO_REG (0x50001710)

Bit	Mode	Symbol	Description	Reset
15:0	R0/W	IR_REPEAT_FIFO_D ATA	Repeat FIFO data write port	0x0

Table 469: IR_IRQ_STATUS_REG (0x50001712)

Bit	Mode	Symbol	Description	Reset
0	R	IR_IRQ_ACK	When read Interrupt line is cleared	0x0

37.15 USB REGISTER FILE

Table 470: Register map USB

Address	Port	Description
0x50001800	USB_MCTRL_REG	Main Control Register)
0x50001802	USB_XCVDIAG_REG	Transceiver diagnostic Register (for test purpose only)
0x50001804	USB_TCR_REG	Transceiver configuration Register
0x50001806	USB_UTR_REG	USB test Register (for test purpose only)
0x50001808	USB_FAR_REG	Function Address Register
0x5000180A	USB_NFSR_REG	Node Functional State Register
0x5000180C	USB_MAEV_REG	Main Event Register
0x5000180E	USB_MAMSK_REG	Main Mask Register
0x50001810	USB_ALTEV_REG	Alternate Event Register
0x50001812	USB_ALTMSK_REG	Alternate Mask Register
0x50001814	USB_TXEV_REG	Transmit Event Register
0x50001816	USB_TXMSK_REG	Transmit Mask Register
0x50001818	USB_RXEV_REG	Receive Event Register
0x5000181A	USB_RXMSK_REG	Receive Mask Register
0x5000181C	USB_NAKEV_REG	NAK Event Register
0x5000181E	USB_NAKMSK_REG	NAK Mask Register
0x50001820	USB_FWEV_REG	FIFO Warning Event Register
0x50001822	USB_FWMSK_REG	FIFO Warning Mask Register
0x50001824	USB_FNH_REG	Frame Number High Byte Register
0x50001826	USB_FNL_REG	Frame Number Low Byte Register
0x5000183E	USB_UX20CDR_REG	Transceiver 2.0 Configuration and Diagnostics Register(for test purpose only)
0x50001840	USB_EPC0_REG	Endpoint Control 0 Register
0x50001842	USB_TXD0_REG	Transmit Data 0 Register
0x50001844	USB_TXS0_REG	Transmit Status 0 Register
0x50001846	USB_TXC0_REG	Transmit command 0 Register
0x50001848	USB_EP0_NAK_REG	EP0 INNAK and OUTNAK Register
0x5000184A	USB_RXD0_REG	Receive Data 0 Register
0x5000184C	USB_RXS0_REG	Receive Status 0 Register
0x5000184E	USB_RXC0_REG	Receive Command 0 Register
0x50001850	USB_EPC1_REG	Endpoint Control Register 1
0x50001852	USB_TXD1_REG	Transmit Data Register 1
0x50001854	USB_TXS1_REG	Transmit Status Register 1
0x50001856	USB_TXC1_REG	Transmit Command Register 1
0x50001858	USB_EPC2_REG	Endpoint Control Register 2
0x5000185A	USB_RXD1_REG	Receive Data Register,1
0x5000185C	USB_RXS1_REG	Receive Status Register 1
0x5000185E	USB_RXC1_REG	Receive Command Register 1
0x50001860	USB_EPC3_REG	Endpoint Control Register 3
0x50001862	USB_TXD2_REG	Transmit Data Register 2
0x50001864	USB_TXS2_REG	Transmit Status Register 2
0x50001866	USB_TXC2_REG	Transmit Command Register 2
0x50001868	USB_EPC4_REG	Endpoint Control Register 4
0x5000186A	USB_RXD2_REG	Receive Data Register 2

Table 470: Register map USB

Address	Port	Description
0x5000186C	USB_RXS2_REG	Receive Status Register 2
0x5000186E	USB_RXC2_REG	Receive Command Register 2
0x50001870	USB_EPC5_REG	Endpoint Control Register 5
0x50001872	USB_TXD3_REG	Transmit Data Register 3
0x50001874	USB_TXS3_REG	Transmit Status Register 3
0x50001876	USB_TXC3_REG	Transmit Command Register 3
0x50001878	USB_EPC6_REG	Endpoint Control Register 6
0x5000187A	USB_RXD3_REG	Receive Data Register 3
0x5000187C	USB_RXS3_REG	Receive Status Register 3
0x5000187E	USB_RXC3_REG	Receive Command Register 3
0x500018D0	USB_DMA_CTRL_REG	USB DMA control register
0x500018D4	USB_CHARGER_CTRL_REG	USB Charger Control Register
0x500018D6	USB_CHARGER_STAT_REG	USB Charger Status Register

Table 471: USB_MCTRL_REG (0x50001800)

Bit	Mode	Symbol	Description	Reset
15:5	-	-	Reserved	0x0
4	R/W	LSMODE	Low Speed Mode This bit enables USB 1.5 Mbit/s low speed and swaps D+ and D- pull-up resistors. Changing speed may only be done if USBEN is set to 0. Also D+ and D- rise and fall times are adjusted according to the USB specification.	0x0
3	R/W	USB_NAT	Node Attached This bit indicates that this node is ready to be detected as attached to USB. When cleared to 0 the transceiver forces SE0 on the USB port to prevent the hub (to which this node is connected to) from detecting an attach event. After reset or when the USB node is disabled, this bit is cleared to 0 to give the device time before it must respond to commands. After this bit has been set to 1, the device no longer drives the USB and should be ready to receive Reset signalling from the hub. Note: This bit can only be set is USBEN is '1'	0x0
2	-	-	Reserved	0x0
1	R/W	USB_DBG	Debug Mode. When this bit is set, the following registers are writable: Main Event (MAEV), Alternate Event (ALTEV), NAK Event (NAKEV), Transmit Status and Receive Status. Setting the DBG bit forces the node into a locked state. The node states can be read out of the transceiver diagnostic register (XCV-DIAG) at location 0xFF6802 by setting the DIAG bit in the Test Control register (UTR). Note: The operation of CoR bits is not effected by entering Debug mode) Note: This bit can only be set is USBEN is '1'	0x0

Table 471: USB_MCTRL_REG (0x50001800)

Bit	Mode	Symbol	Description	Reset
0	R/W	USBEN	<p>USB EnableSetting this bit to 1 enables the Full/Low Speed USB node. If the USBEN bit is cleared to 0, the USB is disabled and the 48 MHz clock within the USB node is stopped. In addition, all USB registers are set to their reset state, except for the mentioned registers in Note 45</p> <p>Note that the transceiver forces SE0 on the bus to prevent the hub to detected the USB node, when it is disabled (not attached). The USBEN bit is cleared to 0 after reset</p>	0x0

Table 472: USB_XCVDIAG_REG (0x50001802)

Bit	Mode	Symbol	Description	Reset
15:8	-	-	Reserved	0x0
7	R	USB_VPIN	With Bit0 = 1 this bit shows the level of the USB_Dp receive data from transceiver; i.e. D+ <= VSE.	0x0
6	R	USB_VMIN	With Bit0 = 1 this bit shows the level USB_Dm receive data from transceiver; i.e. D- <= VSE.	0x0
5	R	USB_RCV	With Bit0 = 1 this bit shows the differential level of the receive comparator.	0x0
4	-	-	Reserved	0x0
3	R/W	USB_XCV_TXEN	With Bit0 = 1, this bit enables test Bits 2,1. Must be kept to '0' for normal operation	0x0
2	R/W	USB_XCV_TXN	With Bit3,0 = 1, this bit sets USB_Dm to a high level, independent of LSMODE selection	0x0
1	R/W	USB_XCV_TXP	With Bit3,0 = 1, this bit sets USB_Dp to a high level, independent of LSMODE selection	0x0
0	R/W	USB_XCV_TEST	<p>Enable USB_XCVDIAG_REG</p> <p>0: Normal operation, test bits disabled</p> <p>1: Enable test bits 7,6,5,3,2,1 (Note 48)</p>	0x0

Table 473: USB_TCR_REG (0x50001804)

Bit	Mode	Symbol	Description	Reset
15:8	-	-	Reserved	0x0
7:5	R/W	USB_VADJ	<p>Reference Voltage/ Threshold voltage AdjustControls the single-ended receiver threshold.</p> <p>Shall not be modified unless instructed by Dialog Semiconductor</p> <p>Only enabled if USB_UTR_REG[7] = 1</p>	0x4
4:0	R/W	USB_CADJ	<p>Transmitter Current Adjust</p> <p>Controls the driver edge rate control current.</p> <p>Shall not be modified unless instructed by Dialog Semiconductor</p> <p>Only enabled if USB_UTR_REG[7] = 1</p>	0x10

Table 474: USB_UTR_REG (0x50001806)

Bit	Mode	Symbol	Description	Reset
15:8	-	-	Reserved	0x0
7	R/W	USB_DIAG	Diagnostic enable '0': Normal operational. '1': Access to the USB_XCVDIAG_REG and USB_TCR_REG enabled. For diagnostic purposes only	0x0
6	R/W	USB_NCRC	No CRC16 When this bit is set to 1, all packets transmitted by the Full/Low Speed USB node are sent without a trailing CRC16. Receive operations are unaffected. This mode is used to check that CRC errors can be detected by other nodes. For diagnostic purposes only	0x0
5	R/W	USB_SF	Short Frame Enables the Frame timer to lock and track, short, non-compliant USB frame sizes. The Short Frame bit should not be set during normal operation. For test purposes only	0x0
4:0	R/W	USB_UTR_RES	Reserved. Must be kept to '0'	0x0

Table 475: USB_FAR_REG (0x50001808)

Bit	Mode	Symbol	Description	Reset
15:8	-	-	Reserved	0x0
7	R/W	USB_AD_EN	Address Enable When set to 1, USB address field bits 6-0 are used in address comparison (see Address detection on page 218 for a description). When cleared to 0, the device does not respond to any token on the USB bus. Note: If the DEF bit in the Endpoint Control 0 register is set, Endpoint 0 responds to the default address.	0x0
6:0	R/W	USB_AD	Address This field holds the 7-bit function address used to transmit and receive all tokens addressed to this device.	0x0

Table 476: USB_NFSR_REG (0x5000180A)

Bit	Mode	Symbol	Description	Reset
15:2	-	-	Reserved	0x0

Table 476: USB_NFSR_REG (0x5000180A)

Bit	Mode	Symbol	Description	Reset
1:0	R/W	USB_NFS	<p>The Node Functional State Register reports and controls the current functional state of the USB node.</p> <p>00: NodeReset This is the USB Reset state. This is entered upon a module reset or by software upon detection of a USB Reset. Upon entry, all endpoint pipes are disabled. DEF in the Endpoint Control 0 (EPC0) register and AD_EN in the Function Address (FAR) register should be cleared by software on entry to this state. On exit, DEF should be reset so the device responds to the default address.</p> <p>01: NodeResume In this state, resume K signalling is generated. This state should be entered by firmware to initiate a remote wake-up sequence by the device. The node must remain in this state for at least 1 ms and no more than 15 ms.</p> <p>10: NodeOperational This is the normal operational state. In this state the node is configured for operation on the USB bus.</p> <p>11: NodeSuspend Suspend state should be entered by firmware on detection of a Suspend event while in Operational state. While in Suspend state, the transceivers operate in their low-power suspend mode. All endpoint controllers and the bits TX_EN, LAST and RX_EN are reset, while all other internal states are frozen. On detection of bus activity, the RESUME bit in the ALTEV register is set. In response, software can cause entry to NodeOperational state.</p>	0x0

Table 477: USB_MAEV_REG (0x5000180C)

Bit	Mode	Symbol	Description	Reset
15:12	-	-	Reserved	0x0
11	R/W	USB_CH_EV	<p>USB Charger event This bit is set if one of the bits in USB_CHARGER_STAT_REG[2-0] change. This bit is cleared to 0 when if USB_CHARGER_STAT_REG is read.</p>	0x0
10	R/W	USB_EP0_NAK	<p>Endpoint 0 NAK Event This bit is an OR of EP0_NAK_REG[EP0_OUTNAK] and EP0_NAK_REG[EP0_INNAK] bits. USB_EP0_NAK is cleared to 0 when EP0_NAK_REG is read.</p>	0x0
9	R/W	USB_EP0_RX	<p>Endpoint 0 Receive Event This bit is a copy of the RXS0[RX_LAST] and is cleared to 0 when this RXS0 register is read. Note: Since Endpoint 0 implements a store and forward principle, an overrun condition for FIFO0 cannot occur</p>	0x0
8	R/W	USB_EP0_TX	<p>Endpoint 0 Transmit Event This bit is a copy of the TXS0[TX_DONE] bit and is cleared to 0 when the TXS0 register is read. Note: Since Endpoint 0 implements a store and forward principle, an underrun condition for FIFO0 cannot occur.</p>	0x0
7	R/W	USB_INTR	<p>Master Interrupt Enable This bit is hardwired to 0 in the Main Event (MAEV) register; bit 7 in the Main Mask (MAMSK) register is the Master Interrupt Enable.</p>	0x0

Table 477: USB_MAEV_REG (0x5000180C)

Bit	Mode	Symbol	Description	Reset
6	R/W	USB_RX_EV	Receive Event This bit is set to 1 if any of the unmasked bits in the Receive Event (RXEV) register is set to 1. It indicates that a SETUP or OUT transaction has been completed. This bit is cleared to 0 when all of the RX_LAST bits in each Receive Status (RXSn) register and all RXOVRN bits in the RXEV register are cleared to 0.	0x0
5	R/W	USB_ULD	Unlocked/Locked Detected This bit is set to 1, when the frame timer has either entered unlocked condition from a locked condition, or has re-entered a locked condition from an unlocked condition as determined by the UL bit in the Frame Number (FNH or FNL) register. This bit is cleared to 0 when the register is read.	0x0
4	R/W	USB_NAK	Negative Acknowledge Event This bit indicates that one of the unmasked NAK Event (NAKEV) register bits has been set to 1. This bit is cleared to 0 when the NAKEV register is read.	0x0
3	R/W	USB_FRAME	Frame Event This bit is set to 1, if the frame counter is updated with a new value. This can be due to the receipt of a valid SOF packet on the USB or to an artificial update if the frame counter was unlocked or a frame was missed. This bit is cleared to 0 when the register is read.	0x0
2	R/W	USB_TX_EV	Transmit Event This bit is set to 1, if any of the unmasked bits in the Transmit Event (TXEV) register (TXFIFOn or TXUNDRNn) is set to 1. Therefore, it indicates that an IN transaction has been completed. This bit is cleared to 0 when all the TX_DONE bits and the TXUNDRN bits in each Transmit Status (TXSn) register are cleared to 0.	0x0
1	R/W	USB_ALT	Alternate Event This bit indicates that one of the unmasked ALTEV register bits has been set to 1. This bit is cleared to 0 by reading the ALTEV register.	0x0
0	R/W	USB_WARN	Warning Event This bit indicates that one of the unmasked bits in the FIFO Warning Event (FWEV) register has been set to 1. This bit is cleared to 0 by reading the FWEV register.	0x0

Table 478: USB_MAMSK_REG (0x5000180E)

Bit	Mode	Symbol	Description	Reset
15:12	-	-	Reserved	0x0
11	R/W	USB_M_CH_EV	The Main Mask Register masks out events reported in the MAEV registers. A bit set to 1, enables the interrupts for the respective event in the MAEV register. If the corresponding bit is cleared to 0, interrupt generation for this event is disabled. Same Bit Definition as MAEV Register	0x0
10	R/W	USB_M_EP0_NAK	Same Bit Definition as MAEV Register	0x0
9	R/W	USB_M_EP0_RX	Same Bit Definition as MAEV Register	0x0
8	R/W	USB_M_EP0_TX	Same Bit Definition as MAEV Register	0x0
7	R/W	USB_M_INTR	Same Bit Definition as MAEV Register	0x0
6	R/W	USB_M_RX_EV	Same Bit Definition as MAEV Register	0x0
5	R/W	USB_M_ULD	Same Bit Definition as MAEV Register	0x0

Table 478: USB_MAMSK_REG (0x5000180E)

Bit	Mode	Symbol	Description	Reset
4	R/W	USB_M_NAK	Same Bit Definition as MAEV Register	0x0
3	R/W	USB_M_FRAME	Same Bit Definition as MAEV Register	0x0
2	R/W	USB_M_TX_EV	Same Bit Definition as MAEV Register	0x0
1	R/W	USB_M_ALT	Same Bit Definition as MAEV Register	0x0
0	R/W	USB_M_WARN	Same Bit Definition as MAEV Register	0x0

Table 479: USB_ALTEV_REG (0x50001810)

Bit	Mode	Symbol	Description	Reset
15:8	-	-	Reserved	0x0
7	R/W	USB_RESUME	Resume Resume signalling is detected on the USB when the device is in Suspend state (NFS in the NFSR register is set to SUSPEND), and a non IDLE signal is present on the USB, indicating that this device should begin it's wake-up sequence and enter Operational state. This bit is cleared when the register is read.	0x0
6	R/W	USB_RESET	Reset This bit is set to 1, when 2.5 μ s of SEO have been detected on the upstream port. In response, the functional state should be reset (NFS in the NFSR register is set to RESET), where it must remain for at least 100 μ s. The functional state can then return to Operational state. This bit is cleared when the register is read	0x0
5	R/W	USB_SD5	Suspend Detect 5 ms This bit is set to 1 after 5 ms of IDLE have been detected on the upstream port, indicating that this device is permitted to perform a remote wake-up operation. The resume may be initiated under firmware control by writing the resume value to the NFSR register. This bit is cleared when the register is read.	0x0
4	R/W	USB_SD3	Suspend Detect 3 ms This bit is set to 1 after 3 ms of IDLE have been detected on the upstream port, indicating that the device should be suspended. The suspend occurs under firmware control by writing the suspend value to the Node Functional State (NFSR) register. This bit is cleared when the register is read.	0x0
3	R/W	USB_EOP	End of Packet A valid EOP sequence was been detected on the USB. It is used when this device has initiated a Remote wake-up sequence to indicate that the Resume sequence has been acknowledged and completed by the host. This bit is cleared when the register is read.	0x0
2	-	-	Reserved	0x0
1:0	-	-	Reserved	0x0

Table 480: USB_ALTMSK_REG (0x50001812)

Bit	Mode	Symbol	Description	Reset
15:8	-	-	Reserved	0x0

Table 480: USB_ALTMSK_REG (0x50001812)

Bit	Mode	Symbol	Description	Reset
7	R/W	USB_M_RESUME	A bit set to 1 in this register enables automatic setting of the ALT bit in the MAEV register when the respective event in the ALTEV register occurs. Otherwise, setting MAEV.ALT bit is disabled. Same Bit Definition as ALTEV Register	0x0
6	R/W	USB_M_RESET	Same Bit Definition as ALTEV Register	0x0
5	R/W	USB_M_SD5	Same Bit Definition as ALTEV Register	0x0
4	R/W	USB_M_SD3	Same Bit Definition as ALTEV Register	0x0
3	R/W	USB_M_EOP	Same Bit Definition as ALTEV Register	0x0
2	-	-	Reserved	0x0
1:0	-	-	Reserved	0x0

Table 481: USB_TXEV_REG (0x50001814)

Bit	Mode	Symbol	Description	Reset
15:7	-	-	Reserved	0x0
6:4	R	USB_TXUDRRN31	Transmit Underrun n: 3:1 The bit n is a copy of the respective TX_URUN bit from the corresponding Transmit Status register (TXSn). Whenever any of the Transmit FIFOs underflows, the respective TXUDRRN bit is set to 1. These bits are cleared to 0 when the corresponding Transmit Status register is read	0x0
3	-	-	Reserved	0x0
2:0	R	USB_TXFIFO31	Transmit FIFO n: 3:1 The bit n is a copy of the TX_DONE bit from the corresponding Transmit Status register (TXSn). A bit is set to 1 when the IN transaction for the corresponding transmit endpoint n has been completed. These bits are cleared to 0 when the corresponding TXSn register is read.	0x0

Table 482: USB_TXMSK_REG (0x50001816)

Bit	Mode	Symbol	Description	Reset
15:7	-	-	Reserved	0x0
6:4	R/W	USB_M_TXUDRRN31	The Transmit Mask Register is used to select the bits of the TXEV registers, which causes the TX_EV bit in the MAEV register to be set to 1. When a bit is set to 1 and the corresponding bit in the TXEV register is set to 1, the TX_EV bit in the MAEV register is set to 1. When cleared to 0, the corresponding bit in the TXEV register does not cause TX_EV to be set to 1. Same Bit Definition as TXEV Register	0x0
3	-	-	Reserved	0x0
2:0	R/W	USB_M_TXFIFO31	Same Bit Definition as TXEV Register	0x0

Table 483: USB_RXEV_REG (0x50001818)

Bit	Mode	Symbol	Description	Reset
15:7	-	-	Reserved	0x0

Table 483: USB_RXEV_REG (0x50001818)

Bit	Mode	Symbol	Description	Reset
6:4	R	USB_RXOVRN31	Receive Overrun n: 3:1 The bit n is set to 1 in the event of an overrun condition in the corresponding receive FIFO n. They are cleared to 0 when the register is read. The firmware must check the respective RX_ERR bits that packets received for the other receive endpoints (EP2, EP4 and EP6,) are not corrupted by errors, as these endpoints support data streaming (packets which are longer than the actual FIFO depth).	0x0
3	-	-	Reserved	0x0
2:0	R	USB_RXFIFO31	Receive FIFO n: 3:1 The bit n is set to 1 whenever either RX_ERR or RX_LAST in the respective Receive Status register (RXSn) is set to 1. Reading the corresponding RXSn register automatically clears these bits. The CoR function is disabled, when the Freeze signal is asserted. The USB node discards all packets for Endpoint 0 received with errors. This is necessary in case of retransmission due to media errors, ensuring that a good copy of a SETUP packet is captured. Otherwise, the FIFO may potentially be tied up, holding corrupted data and unable to receive a retransmission of the same packet. If data streaming is used for the receive endpoints (EP2, EP4 and EP6, EP8) the firmware must check the respective RX_ERR bits to ensure the packets received are not corrupted by errors.	0x0

Table 484: USB_RXMSK_REG (0x5000181A)

Bit	Mode	Symbol	Description	Reset
15:7	-	-	Reserved	0x0
6:4	R/W	USB_M_RXOVRN31	The Receive Mask Register is used to select the bits of the RXEV registers, which causes the RX_EV bit in the MAEV register to be set to 1. When set to 1 and the corresponding bit in the RXEV register is set to 1, RX_EV bit in the MAEV register is set to 1. When cleared to 0, the corresponding bit in the RXEV register does not cause RX_EV to be set to 1. Same Bit Definition as RXEV Register	0x0
3	-	-	Reserved	0x0
2:0	R/W	USB_M_RXFIFO31	Same Bit Definition as RXEV Register	0x0

Table 485: USB_NAKEV_REG (0x5000181C)

Bit	Mode	Symbol	Description	Reset
15:7	-	-	Reserved	0x0
6:4	R	USB_OUT31	OUT n: 3:1 The bit n is set to 1 when a NAK handshake is generated for an enabled address/endpoint combination (AD_EN in the FAR register is set to 1 and EP_EN in the EPCx register is set to 1) in response to an OUT token. This bit is not set if NAK is generated as result of an overrun condition. It is cleared when the register is read.	0x0
3	-	-	Reserved	0x0

Table 485: USB_NAKEV_REG (0x5000181C)

Bit	Mode	Symbol	Description	Reset
2:0	R	USB_IN31	IN n: 3:1 The bit n is set to 1 when a NAK handshake is generated for an enabled address/endpoint combination (AD_EN in the Function Address, FAR, register is set to 1 and EP_EN in the Endpoint Control, EPCx, register is set to 1) in response to an IN token. This bit is cleared when the register is read.	0x0

Table 486: USB_NAKMSK_REG (0x5000181E)

Bit	Mode	Symbol	Description	Reset
15:7	-	-	Reserved	0x0
6:4	R/W	USB_M_OUT31	When set and the corresponding bit in the NAKEV register is set, the NAK bit in the MAEV register is set. When cleared, the corresponding bit in the NAKEV register does not cause NAK to be set. Same Bit Definition as NAKEV Register	0x0
3	-	-	Reserved	0x0
2:0	R/W	USB_M_IN31	Same Bit Definition as NAKEV Register	0x0

Table 487: USB_FWEV_REG (0x50001820)

Bit	Mode	Symbol	Description	Reset
15:7	-	-	Reserved	0x0
6:4	R	USB_RXWARN31	Receive Warning n: 3:1 The bit n is set to 1 when the respective receive endpoint FIFO reaches the warning limit, as specified by the RFWL bits of the respective EPCx register. This bit is cleared when the warning condition is cleared by either reading data from the FIFO or when the FIFO is flushed.	0x0
3	-	-	Reserved	0x0
2:0	R	USB_TXWARN31	Transmit Warning n: 3:1 The bit n is set to 1 when the respective transmit endpoint FIFO reaches the warning limit, as specified by the TFWL bits of the respective TXCn register, and transmission from the respective endpoint is enabled. This bit is cleared when the warning condition is cleared by either writing new data to the FIFO when the FIFO is flushed, or when transmission is done, as indicated by the TX_DONE bit in the TXSn register.	0x0

Table 488: USB_FWMSK_REG (0x50001822)

Bit	Mode	Symbol	Description	Reset
15:7	-	-	Reserved	0x0
6:4	R/W	USB_M_RXWARN31	The FIFO Warning Mask Register selects, which FWEV bits are reported in the MAEV register. A bit set to 1 and the corresponding bit in the FWEV register is set 1, causes the WARN bit in the MAEV register to be set to 1. When cleared to 0, the corresponding bit in the FWEV register does not cause WARN to be set to 1. Same Bit Definition as FWEV Register	0x0
3	-	-	Reserved	0x0

Table 488: USB_FWMSK_REG (0x50001822)

Bit	Mode	Symbol	Description	Reset
2:0	R/W	USB_M_TXWARN31	The FIFO Warning Mask Register selects, which FWEV bits are reported in the MAEV register. A bit set to 1 and the corresponding bit in the FWEV register is set 1, causes the WARN bit in the MAEV register to be set to 1. When cleared to 0, the corresponding bit in the FWEV register does not cause WARN to be set to 1. Same Bit Definition as FWEV Register	0x0

Table 489: USB_FNH_REG (0x50001824)

Bit	Mode	Symbol	Description	Reset
15:8	-	-	Reserved	0x0
7	R	USB_MF	Missed SOF Flag This flag is set to 1, when the frame number in a valid received SOF does not match the expected next value, or when an SOF is not received within 12060 bit times. This bit is set by the hardware and is cleared by reading the FNH register.	0x1
6	R	USB_UL	Unlock Flag This bit indicates that at least two frames were received without an expected frame number, or that no valid SOF was received within 12060 bit times. If this bit is set, the frame number from the next valid SOF packet is loaded in FN. This bit is set by the hardware and is cleared by reading the FNH register.	0x1
5	R	USB_RFC	Reset Frame Count Writing a 1 to this bit resets the frame number to 00016, after which this bit clears itself to 0 again. This bit always reads 0.	0x0
4:3	-	-	Reserved	0x0
2:0	R	USB_FN_10_8	Frame Number This 3-bit field contains the three most significant bits (MSB) of the current frame number, received in the last SOF packet. If a valid frame number is not received within 12060 bit times (Frame Length Maximum, FLMAX, with tolerance) of the previous change, the frame number is incremented artificially. If two successive frames are missed or are incorrect, the current FN is frozen and loaded with the next frame number from a valid SOF packet. If the frame number low byte was read by firmware before reading the FNH register, the user actually reads the contents of a buffer register which holds the value of the three frame number bits of this register when the low byte was read. Therefore, the correct sequence to read the frame number is: FNL, FNH. Read operations to the FNH register, without first reading the Frame Number Low Byte (FNL) register directly, read the actual value of the three MSBs of the frame number.	0x0

Table 490: USB_FNL_REG (0x50001826)

Bit	Mode	Symbol	Description	Reset
15:8	-	-	Reserved	0x0

Table 490: USB_FNL_REG (0x50001826)

Bit	Mode	Symbol	Description	Reset
7:0	R	USB_FN	The Frame Number Low Byte Register holds the low byte of the frame number. To ensure consistency, reading this low byte causes the three frame number bits in the FNH register to be locked until this register is read. The correct sequence to read the frame number is: FNL, FNH.	0x0

Table 491: USB_UX20CDR_REG (0x5000183E)

Bit	Mode	Symbol	Description	Reset
15:8	-	-	Reserved	0x0
7	R	RPU_TEST7	Test bit	0x0
6	R/W	RPU_TEST_SW2	0: Closes SW2 switch to reduced pull-up resistor connected to the USB_Dp and USB_Dm. 1: Opens SW2 switch resistor connected to the USB_Dp and USB_Dm (independent of the VBus state). (Note 47)	0x0
5	R/W	RPU_TEST_SW1	0: Enable the pull-up resistor on USB_Dp (SW1 closed) 1: Disable the pull-up resistor on USB_Dp (SW1 open) (Independent of the VBus state). (Note 47)	0x0
4	R/W	RPU_TEST_EN	Pull-Up Resistor Test Enable 0: Normal operation 1: Enables the test features controlled by RPU_TEST_SW1, RPU_TEST_SW1DM and RPU_TEST_SW2 (Note 47)	0x0
3	-	-	Reserved	0x0
2	R/W	RPU_TEST_SW1DM	0: Enable the pull-up resistor on USB_Dm (SW1DM closed) 1: Disable the pull-up resistor on USB_Dm (SW1DM open) (Independent of the VBus state). (Note 47)	0x0
1	R/W	RPU_RCDELAY	Test bit, must be kept 0	0x0
0	R/W	RPU_SSPROTEN	Test bit, must be kept 0	0x0

Table 492: USB_EPC0_REG (0x50001840)

Bit	Mode	Symbol	Description	Reset
15:8	-	-	Reserved	0x0
7	R/W	USB_STALL	Stall Setting this bit to 1 causes the chip to generate STALL handshakes under the following conditions: - The transmit FIFO is enabled and an IN token is received. - The receive FIFO is enabled and an OUT token is received. Note: A SETUP token does not cause a STALL handshake to be generated when this bit is set. Upon transmitting the STALL handshake, the RX_LAST and the TX_DONE bits in the respective Receive/Transmit Status registers are set to 1.	0x0

Table 492: USB_EPC0_REG (0x50001840)

Bit	Mode	Symbol	Description	Reset
6	R/W	USB_DEF	<p>Default Address</p> <p>When set to 1, the device responds to the default address regardless of the contents of FAR6-0/EP03-0 fields. When an IN packet is transmitted for the endpoint, the DEF bit is automatically cleared to 0.</p> <p>This bit aids in the transition from default address to assigned address. The transition from the default address 00000000000b to an address assigned during bus enumeration may not occur in the middle of the SET_ADDRESS control sequence. This is necessary to complete the control sequence. However, the address must change immediately after this sequence finishes in order to avoid errors when another control sequence immediately follows the SET_ADDRESS command.</p> <p>On USB reset, the firmware has 10 ms for set-up, and should write 8016 to the FAR register and 0016 to the EPC0 register. On receipt of a SET_ADDRESS command, the firmware must write 4016 to the EPC0 register and (8016 or <assigned_function_address>) to the FAR register. It must then queue a zero length IN packet to complete the status phase of the SET_ADDRESS control sequence.</p>	0x0
5:4	-	-	Reserved	0x0
3:0	R	USB_EP	<p>Endpoint Address</p> <p>This field holds the 4-bit Endpoint address. For Endpoint 0, these bits are hardwired to 0000b. Writing a 1 to any of the EP bits is ignored.</p>	0x0

Table 493: USB_TXD0_REG (0x50001842)

Bit	Mode	Symbol	Description	Reset
15:8	-	-	Reserved	0x0
7:0	W	USB_TXFD	<p>Transmit FIFO Data Byte</p> <p>See Bidirectional Control Endpoint FIFO0 on page 220 for a description of data handling.</p> <p>The firmware is expected to write only the packet payload data. The PID and CRC16 are created automatically.</p>	0x0

Table 494: USB_TXS0_REG (0x50001844)

Bit	Mode	Symbol	Description	Reset
15:7	-	-	Reserved	0x0
6	R	USB_ACK_STAT	<p>Acknowledge Status</p> <p>This bit indicates the status, as received from the host, of the ACK for the packet previously sent. This bit is to be interpreted when TX_DONE is set to 1. It is set to 1, when an ACK is received; otherwise, it remains cleared. This bit is also cleared to 0, when this register is read.</p>	0x0
5	R	USB_TX_DONE	<p>Transmission Done</p> <p>When set to 1, this bit indicates that a packet has completed transmission. It is cleared to 0, when this register is read.</p>	0x0
4:0	R	USB_TCOUNT	<p>Transmission Count</p> <p>This 5-bit field indicates the number of empty bytes available in the FIFO. This field is never larger than 8 for Endpoint 0.</p>	0x8

Table 495: USB_TXC0_REG (0x50001846)

Bit	Mode	Symbol	Description	Reset
15:5	-	-	Reserved	0x0
4	R/W	USB_IGN_IN	Ignore IN Tokens When this bit is set to 1, the endpoint will ignore any IN tokens directed to its configured address.	0x0
3	R/W	USB_FLUSH	Flush FIFO Writing a 1 to this bit flushes all data from the control endpoint FIFOs, resets the endpoint to Idle state, clears the FIFO read and write pointer, and then clears itself. If the endpoint is currently using the FIFO0 to transfer data on USB, flushing is delayed until after the transfer is done. It is equivalent to the FLUSH bit in the RXC0 register.	0x0
2	R/W	USB_TOGGLE_TX0	Toggle This bit specifies the PID used when transmitting the packet. A value of 0 causes a DATA0 PID to be generated, while a value of 1 causes a DATA1 PID to be generated. This bit is not altered by the hardware.	0x0
1	-	-	Reserved	0x0
0	R/W	USB_TX_EN	Transmission Enable This bit enables data transmission from the FIFO. It is cleared to 0 by hardware after transmitting a single packet, or a STALL handshake, in response to an IN token. It must be set to 1 by firmware to start packet transmission. The RX_EN bit in the Receive Command 0 (RXC0) register takes precedence over this bit; i.e. if RX_EN is set, TX_EN bit is ignored until RX_EN is reset. Zero length packets are indicated by setting this bit without writing any data to the FIFO.	0x0

Table 496: USB_EP0_NAK_REG (0x50001848)

Bit	Mode	Symbol	Description	Reset
15:2	-	-	Reserved	0x0
1	R	USB_EP0_OUTNAK	End point 0 OUT NAK This bit is set to 1 when a NAK handshake is generated for an enabled address/endpoint combination (AD_EN in the FAR register is set to 1) in response to an OUT token. This bit is not set if NAK is generated as result of an overrun condition. It is cleared when the register is read.	0x0
0	R	USB_EP0_INNAK	End point 0 IN NAK This bit is set to 1 when a NAK handshake is generated for an enabled address/endpoint combination (AD_EN in the FAR register is set to 1) in response to an IN token. This bit is cleared when the register is read.	0x0

Table 497: USB_RXD0_REG (0x5000184A)

Bit	Mode	Symbol	Description	Reset
15:8	-	-	Reserved	0x0

Table 497: USB_RXD0_REG (0x5000184A)

Bit	Mode	Symbol	Description	Reset
7:0	R	USB_RXFD	Receive FIFO Data Byte See Bidirectional Control Endpoint FIFO0 on page 220 for a description of data handling. The firmware should expect to read only the packet payload data. The PID and CRC16 are removed from the incoming data stream automatically. In TEST mode this register allow read/write access.	0x0

Table 498: USB_RXS0_REG (0x5000184C)

Bit	Mode	Symbol	Description	Reset
15:8	-	-	Reserved	0x0
7	-	-	Reserved	0x0
6	R	USB_SETUP	Setup This bit indicates that the setup packet has been received. This bit is unchanged for zero length packets. It is cleared to 0 when this register is read.	0x0
5	R	USB_TOGGLE_RX0	Toggle This bit specified the PID used when receiving the packet. A value of 0 indicates that the last successfully received packet had a DATA0 PID, while a value of 1 indicates that this packet had a DATA1 PID. This bit is unchanged for zero length packets. It is cleared to 0 when this register is read.	0x0
4	R	USB_RX_LAST	Receive Last Bytes This bit indicates that an ACK was sent upon completion of a successful receive operation. This bit is unchanged for zero length packets. It is cleared to 0 when this register is read.	0x0
3:0	R	USB_RCOUNT	Receive Count This 4-bit field contains the number of bytes presently in the RX FIFO. This number is never larger than 8 for Endpoint 0.	0x0

Table 499: USB_RXC0_REG (0x5000184E)

Bit	Mode	Symbol	Description	Reset
15:6	-	-	Reserved	0x0
5	-	-	Reserved	0x0
4	-	-	Reserved	0x0
3	R/W	USB_FLUSH	Flush Writing a 1 to this bit flushes all data from the control endpoint FIFOs, resets the endpoint to Idle state, clears the FIFO read and write pointer, and then clears itself. If the endpoint is currently using FIFO0 to transfer data on USB, flushing is delayed until after the transfer is done. This bit is cleared to 0 on reset. This bit is equivalent to FLUSH in the TXC0 register.	0x0
2	R/W	USB_IGN_SETUP	Ignore SETUP Tokens When this bit is set to 1, the endpoint ignores any SETUP tokens directed to its configured address.	0x0
1	R/W	USB_IGN_OUT	Ignore OUT Tokens When this bit is set to 1, the endpoint ignores any OUT tokens directed to its configured address.	0x0

Table 499: USB_RXC0_REG (0x5000184E)

Bit	Mode	Symbol	Description	Reset
0	R/W	USB_RX_EN	Receive Enable OUT packet reception is disabled after every data packet is received, or when a STALL handshake is returned in response to an OUT token. A 1 must be written to this bit to re-enable data reception. Reception of SETUP packets is always enabled. In the case of back-to-back SETUP packets (for a given endpoint) where a valid SETUP packet is received with no other intervening non-SETUP tokens, the Endpoint Controller discards the new SETUP packet and returns an ACK handshake. If any other reasons prevent the Endpoint Controller from accepting the SETUP packet, it must not generate a handshake. This allows recovery from a condition where the ACK of the first SETUP token was lost by the host.	0x0

Table 500: USB_EPC1_REG (0x50001850)

Bit	Mode	Symbol	Description	Reset
15:8	-	-	Reserved	0x0
7	R/W	USB_STALL	Stall Setting this bit to 1 causes the chip to generate STALL handshakes under the following conditions: The transmit FIFO is enabled and an IN token is received. The receive FIFO is enabled and an OUT token is received. Setting this bit to 1 does not generate a STALL handshake in response to a SETUP token	0x0
6	-	-	Reserved	0x0
5	R/W	USB_ISO	Isochronous When this bit is set to 1, the endpoint is isochronous. This implies that no NAK is sent if the endpoint is not ready but enabled; i.e. If an IN token is received and no data is available in the FIFO to transmit, or if an OUT token is received and the FIFO is full since there is no USB handshake for isochronous transfers.	0x0
4	R/W	USB_EP_EN	Endpoint Enable When this bit is set to 1, the EP[3:0] field is used in address comparison, together with the AD[6:0] field in the FAR register. See Section 36.8 for a description. When cleared to 0, the endpoint does not respond to any token on the USB bus.	0x0
3:0	R/W	USB_EP	Endpoint Address This 4-bit field holds the endpoint address.	0x0

Table 501: USB_TXD1_REG (0x50001852)

Bit	Mode	Symbol	Description	Reset
15:8	-	-	Reserved	0x0

Table 501: USB_TXD1_REG (0x50001852)

Bit	Mode	Symbol	Description	Reset
7:0	W	USB_TXFD	Transmit FIFO Data Byte See Transmit Endpoint FIFOs on page 222 for a description of endpoint FIFO data handling. The firm- ware is expected to write only the packet payload data. PID and CRC16 are inserted automatically in the transmit data stream. In TEST mode this register allow read/write access via the core bus.	0x0

Table 502: USB_TXS1_REG (0x50001854)

Bit	Mode	Symbol	Description	Reset
15:8	-	-	Reserved	0x0
7	R	USB_TX_URUN	Transmit FIFO Underrun This bit is set to 1, if the transmit FIFO becomes empty dur- ing a transmission, and no new data is written to the FIFO. If so, the Media Access Controller (MAC) forces a bit stuff error followed by an EOP. This bit is cleared to 0, when this regis- ter is read.	0x0
6	R	USB_ACK_STAT	Acknowledge Status This bit is interpreted when TX_DONE is set. It's function dif- fers depending on whether ISO (ISO in the EPCx register is set) or non-ISO operation (ISO is reset) is used. For non-ISO operation, this bit indicates the acknowledge status (from the host) about the ACK for the previously sent packet. This bit itself is set to 1, when an ACK is received; otherwise, it is cleared to 0. For ISO operation, this bit is set if a frame number LSB match (see IGN_ISOMSK bit in the USB_TXCx_REG) occurs, and data was sent in response to an IN token. Other- wise, this bit is cleared to 0, the FIFO is flushed and TX_DONE is set. This bit is also cleared to 0, when this register is read.	0x0
5	R	USB_TX_DONE	Transmission Done When set to 1, this bit indicates that the endpoint responded to a USB packet. Three conditions can cause this bit to be set: A data packet completed transmission in response to an IN token with non-ISO operation. The endpoint sent a STALL handshake in response to an IN token A scheduled ISO frame was transmitted or discarded. This bit is cleared to 0 when this register is read.	0x0
4:0	R	USB_TCOUNT	Transmission Count This 5-bit field holds the number of empty bytes available in the FIFO. If this number is greater than 31, a value of 31 is actually reported.	0x1F

Table 503: USB_TXC1_REG (0x50001856)

Bit	Mode	Symbol	Description	Reset
15:8	-	-	Reserved	0x0

Table 503: USB_TXC1_REG (0x50001856)

Bit	Mode	Symbol	Description	Reset
7	R/W	USB_IGN_ISOMSK	Ignore ISO Mask This bit has an effect only if the endpoint is set to be isochronous. If set to 1, this bit disables locking of specific frame numbers with the alternate function of the TOGGLE bit. Thus data is transmitted upon reception of the next IN token. If cleared to 0, data is only transmitted when FNL0 matches TOGGLE. This bit is cleared to 0 after reset.	0x0
6:5	R/W	USB_TFWL	Transmit FIFO Warning Limit These bits specify how many more bytes can be transmitted from the respective FIFO before an underrun condition occurs. If the number of bytes remaining in the FIFO is equal to or less than the selected warning limit, the TXWARN bit in the FWEV register is set. To avoid interrupts caused by setting this bit while the FIFO is being filled before a transmission begins, TXWARN is only set when transmission from the endpoint is enabled (TX_ENn in the TXCn register is set). TFWL[1:0] : 00: TFWL disabled 01: Less than 5 bytes remaining in FIFO 10: Less than 9 bytes remaining in FIFO 11: Less than 17 bytes remaining in FIFO	0x0
4	R/W	USB_RFF	Refill FIFO Setting the LAST bit to 1 automatically saves the Transmit Read Pointer (TXRP) to a buffer. When the RFF bit is set to 1, the buffered TXRP is reloaded into the TXRP. This allows the user to repeat the last transaction if no ACK was received from the host. If the MAC is currently using the FIFO to transmit, TXRP is reloaded only after the transmission is complete. After reload, this bit is cleared to 0 by hardware.	0x0
3	R/W	USB_FLUSH	Flush FIFO Writing a 1 to this bit flushes all data from the corresponding transmit FIFO, resets the endpoint to Idle state, and clears both the FIFO read and write pointers. If the MAC is currently using the FIFO to transmit, data is flushed after the transmission is complete. After data flushing, this bit is cleared to 0 by hardware.	0x0
2	R/W	USB_TOGGLE_TX	Toggle The function of this bit differs depending on whether ISO (ISO bit in the EPCn register is set to 1) or non-ISO operation (ISO bit is cleared to 0) is used. For non-ISO operation, it specifies the PID used when transmitting the packet. A value of 0 causes a DATA0 PID to be generated, while a value of 1 causes a DATA1 PID to be generated. For ISO operation, this bit and the LSB of the frame counter (FNL0) act as a mask for the TX_EN bit to allow pre-queuing of packets to specific frame numbers; i.e. transmission is enabled only if bit 0 in the FNL register is set to TOGGLE. If an IN token is not received while this condition is true, the contents of the FIFO are flushed with the next SOF. If the endpoint is set to ISO, data is always transferred with a DATA0 PID.	0x0

Table 503: USB_TXC1_REG (0x50001856)

Bit	Mode	Symbol	Description	Reset
1	R/W	USB_LAST	<p>Last Byte</p> <p>Setting this bit to 1 indicates that the entire packet has been written into the FIFO. This is used especially for streaming data to the FIFO while the actual transmission occurs. If the LAST bit is not set to 1 and the transmit FIFO becomes empty during a transmission, a stuff error followed by an EOP is forced on the bus. Zero length packets are indicated by setting this bit without writing any data to the FIFO. The transmit state machine transmits the payload data, CRC16 and the EOP signal before clearing this bit.</p>	0x0
0	R/W	USB_TX_EN	<p>Transmission Enable</p> <p>This bit enables data transmission from the FIFO. It is cleared to 0 by hardware after transmitting a single packet or after a STALL handshake in response to an IN token. It must be set to 1 by firmware to start packet transmission.</p>	0x0

Table 504: USB_EPC2_REG (0x50001858)

Bit	Mode	Symbol	Description	Reset
15:8	-	-	Reserved	0x0
7	R/W	USB_STALL	<p>Stall</p> <p>Setting this bit to 1 causes the chip to generate STALL handshakes under the following conditions:</p> <ul style="list-style-type: none"> The transmit FIFO is enabled and an IN token is received. The receive FIFO is enabled and an OUT token is received. <p>Setting this bit to 1 does not generate a STALL handshake in response to a SETUP token</p>	0x0
6	-	-	Reserved	0x0
5	R/W	USB_ISO	<p>Isochronous</p> <p>When this bit is set to 1, the endpoint is isochronous. This implies that no NAK is sent if the endpoint is not ready but enabled; i.e. If an IN token is received and no data is available in the FIFO to transmit, or if an OUT token is received and the FIFO is full since there is no USB handshake for isochronous transfers.</p>	0x0
4	R/W	USB_EP_EN	<p>Endpoint Enable</p> <p>When this bit is set to 1, the EP[3:0] field is used in address comparison, together with the AD[6:0] field in the FAR register. See Section 36.8 for a description. When cleared to 0, the endpoint does not respond to any token on the USB bus.</p>	0x0
3:0	R/W	USB_EP	<p>Endpoint Address</p> <p>This 4-bit field holds the endpoint address.</p>	0x0

Table 505: USB_RXD1_REG (0x5000185A)

Bit	Mode	Symbol	Description	Reset
15:8	-	-	Reserved	0x0

Table 505: USB_RXD1_REG (0x5000185A)

Bit	Mode	Symbol	Description	Reset
7:0	R	USB_RXFD	Receive FIFO Data Byte See Receive Endpoint FIFO on page 223 for a description of Endpoint FIFO data handling. The firm- ware should expect to read only the packet payload data. The PID and CRC16 are terminated by the receive state machine. In TEST mode this register allow read/write access via the core bus.	0x0

Table 506: USB_RXS1_REG (0x5000185C)

Bit	Mode	Symbol	Description	Reset
15:8	-	-	Reserved	0x0
7	R	USB_RX_ERR	Receive Error When set to 1, this bit indicates a media error, such as bit- stuffing or CRC. If this bit is set to 1, the firmware must flush the respective FIFO.	0x0
6	R	USB_SETUP	Setup This bit indicates that the setup packet has been received. It is cleared when this register is read.	0x0
5	R	USB_TOGGLE_RX	Toggle The function of this bit differs depending on whether ISO (ISO in the EPCn register is set) or non-ISO operation (ISO is reset) is used. For non-ISO operation, a value of 0 indicates that the last successfully received packet had a DATA0 PID, while a value of 1 indicates that this packet had a DATA1 PID. For ISO operation, this bit reflects the LSB of the frame num- ber (FNL0) after a packet was successfully received for this endpoint. This bit is reset to 0 by reading the RXSn register.	0x0
4	R	USB_RX_LAST	Receive Last This bit indicates that an ACK was sent upon completion of a successful receive operation. This bit is cleared to 0 when this register is read.	0x0
3:0	R	USB_RCOUNT	Receive Counter This 4-bit field contains the number of bytes presently in the endpoint receive FIFO. If this number is greater than 15, a value of 15 is actually reported.	0x0

Table 507: USB_RXC1_REG (0x5000185E)

Bit	Mode	Symbol	Description	Reset
15:7	-	-	Reserved	0x0
6:5	R/W	USB_RFWL	Receive FIFO Warning Limit These bits specify how many more bytes can be received to the respective FIFO before an overrun condition occurs. If the number of empty bytes remaining in the FIFO is equal to or less than the selected warning limit, the RXWARN bit in the FWEV register is set to 1. RFWL[1:0] : 00: RFWL disabled 01: Less than 5 bytes remaining in FIFO 10: Less than 9 bytes remaining in FIFO 11: Less than 17 bytes remaining in FIFO	0x0

Table 507: USB_RXC1_REG (0x5000185E)

Bit	Mode	Symbol	Description	Reset
4	-	-	Reserved	0x0
3	R/W	USB_FLUSH	Flush FIFO Writing a 1 to this bit flushes all data from the corresponding receive FIFO, resets the endpoint to Idle state, and resets both the FIFO read and write pointers. If the MAC is currently using the FIFO to receive data, flushing is delayed until after receiving is completed.	0x0
2	R/W	USB_IGN_SETUP	Ignore SETUP Tokens When this bit is set to 1, the endpoint ignores any SETUP tokens directed to its configured address.	0x0
1	-	-	Reserved	0x0
0	R/W	USB_RX_EN	Receive Enable OUT packet cannot be received after every data packet is received, or when a STALL handshake is returned in response to an OUT token. This bit must be written with a 1 to re-enable data reception. SETUP packets can always be received. In the case of back-to-back SETUP packets (for a given endpoint) where a valid SETUP packet has been received with no other intervening non-SETUP tokens, the receive state machine discards the new SETUP packet and returns an ACK handshake. If, for any other reason, the receive state machine cannot accept the SETUP packet, no HANDSHAKE should be generated.	0x0

Table 508: USB_EPC3_REG (0x50001860)

Bit	Mode	Symbol	Description	Reset
15:8	-	-	Reserved	0x0
7	R/W	USB_STALL	Stall Setting this bit to 1 causes the chip to generate STALL handshakes under the following conditions: The transmit FIFO is enabled and an IN token is received. The receive FIFO is enabled and an OUT token is received. Setting this bit to 1 does not generate a STALL handshake in response to a SETUP token	0x0
6	-	-	Reserved	0x0
5	R/W	USB_ISO	Isochronous When this bit is set to 1, the endpoint is isochronous. This implies that no NAK is sent if the endpoint is not ready but enabled; i.e. If an IN token is received and no data is available in the FIFO to transmit, or if an OUT token is received and the FIFO is full since there is no USB handshake for isochronous transfers.	0x0
4	R/W	USB_EP_EN	Endpoint Enable When this bit is set to 1, the EP[3:0] field is used in address comparison, together with the AD[6:0] field in the FAR register. See Section 36.8 for a description. When cleared to 0, the endpoint does not respond to any token on the USB bus.	0x0
3:0	R/W	USB_EP	Endpoint Address This 4-bit field holds the endpoint address.	0x0

Table 509: USB_TXD2_REG (0x50001862)

Bit	Mode	Symbol	Description	Reset
15:8	-	-	Reserved	0x0
7:0	W	USB_TXFD	Transmit FIFO Data Byte See Transmit Endpoint FIFOs on page 222 for a description of endpoint FIFO data handling. The firm- ware is expected to write only the packet payload data. PID and CRC16 are inserted automatically in the transmit data stream. In TEST mode this register allow read/write access via the core bus.	0x0

Table 510: USB_TXS2_REG (0x50001864)

Bit	Mode	Symbol	Description	Reset
15:8	-	-	Reserved	0x0
7	R	USB_TX_URUN	Transmit FIFO Underrun This bit is set to 1, if the transmit FIFO becomes empty dur- ing a transmission, and no new data is written to the FIFO. If so, the Media Access Controller (MAC) forces a bit stuff error followed by an EOP. This bit is cleared to 0, when this regis- ter is read.	0x0
6	R	USB_ACK_STAT	Acknowledge Status This bit is interpreted when TX_DONE is set. It's function dif- fers depending on whether ISO (ISO in the EPCx register is set) or non-ISO operation (ISO is reset) is used. For non-ISO operation, this bit indicates the acknowledge status (from the host) about the ACK for the previously sent packet. This bit itself is set to 1, when an ACK is received; otherwise, it is cleared to 0. For ISO operation, this bit is set if a frame number LSB match (see IGN_ISOMSK bit in the USB_TXCx_REG) occurs, and data was sent in response to an IN token. Other- wise, this bit is cleared to 0, the FIFO is flushed and TX_DONE is set. This bit is also cleared to 0, when this register is read.	0x0
5	R	USB_TX_DONE	Transmission Done When set to 1, this bit indicates that the endpoint responded to a USB packet. Three conditions can cause this bit to be set: A data packet completed transmission in response to an IN token with non-ISO operation. The endpoint sent a STALL handshake in response to an IN token A scheduled ISO frame was transmitted or discarded. This bit is cleared to 0 when this register is read.	0x0
4:0	R	USB_TCOUNT	Transmission Count This 5-bit field holds the number of empty bytes available in the FIFO. If this number is greater than 31, a value of 31 is actually reported.	0x1F

Table 511: USB_TXC2_REG (0x50001866)

Bit	Mode	Symbol	Description	Reset
15:8	-	-	Reserved	0x0

Table 511: USB_TXC2_REG (0x50001866)

Bit	Mode	Symbol	Description	Reset
7	R/W	USB_IGN_ISOMSK	Ignore ISO Mask This bit has an effect only if the endpoint is set to be isochronous. If set to 1, this bit disables locking of specific frame numbers with the alternate function of the TOGGLE bit. Thus data is transmitted upon reception of the next IN token. If cleared to 0, data is only transmitted when FNL0 matches TOGGLE. This bit is cleared to 0 after reset.	0x0
6:5	R/W	USB_TFWL	Transmit FIFO Warning Limit These bits specify how many more bytes can be transmitted from the respective FIFO before an underrun condition occurs. If the number of bytes remaining in the FIFO is equal to or less than the selected warning limit, the TXWARN bit in the FWEV register is set. To avoid interrupts caused by setting this bit while the FIFO is being filled before a transmission begins, TXWARN is only set when transmission from the endpoint is enabled (TX_ENn in the TXCn register is set). TFWL[1:0] : 00: TFWL disabled 01: Less than 5 bytes remaining in FIFO 10: Less than 9 bytes remaining in FIFO 11: Less than 17 bytes remaining in FIFO	0x0
4	R/W	USB_RFF	Refill FIFO Setting the LAST bit to 1 automatically saves the Transmit Read Pointer (TXRP) to a buffer. When the RFF bit is set to 1, the buffered TXRP is reloaded into the TXRP. This allows the user to repeat the last transaction if no ACK was received from the host. If the MAC is currently using the FIFO to transmit, TXRP is reloaded only after the transmission is complete. After reload, this bit is cleared to 0 by hardware.	0x0
3	R/W	USB_FLUSH	Flush FIFO Writing a 1 to this bit flushes all data from the corresponding transmit FIFO, resets the endpoint to Idle state, and clears both the FIFO read and write pointers. If the MAC is currently using the FIFO to transmit, data is flushed after the transmission is complete. After data flushing, this bit is cleared to 0 by hardware.	0x0
2	R/W	USB_TOGGLE_TX	Toggle The function of this bit differs depending on whether ISO (ISO bit in the EPCn register is set to 1) or non-ISO operation (ISO bit is cleared to 0) is used. For non-ISO operation, it specifies the PID used when transmitting the packet. A value of 0 causes a DATA0 PID to be generated, while a value of 1 causes a DATA1 PID to be generated. For ISO operation, this bit and the LSB of the frame counter (FNL0) act as a mask for the TX_EN bit to allow pre-queuing of packets to specific frame numbers; i.e. transmission is enabled only if bit 0 in the FNL register is set to TOGGLE. If an IN token is not received while this condition is true, the contents of the FIFO are flushed with the next SOF. If the endpoint is set to ISO, data is always transferred with a DATA0 PID.	0x0

Table 511: USB_TXC2_REG (0x50001866)

Bit	Mode	Symbol	Description	Reset
1	R/W	USB_LAST	<p>Last Byte</p> <p>Setting this bit to 1 indicates that the entire packet has been written into the FIFO. This is used especially for streaming data to the FIFO while the actual transmission occurs. If the LAST bit is not set to 1 and the transmit FIFO becomes empty during a transmission, a stuff error followed by an EOP is forced on the bus. Zero length packets are indicated by setting this bit without writing any data to the FIFO. The transmit state machine transmits the payload data, CRC16 and the EOP signal before clearing this bit.</p>	0x0
0	R/W	USB_TX_EN	<p>Transmission Enable</p> <p>This bit enables data transmission from the FIFO. It is cleared to 0 by hardware after transmitting a single packet or after a STALL handshake in response to an IN token. It must be set to 1 by firmware to start packet transmission.</p>	0x0

Table 512: USB_EPC4_REG (0x50001868)

Bit	Mode	Symbol	Description	Reset
15:8	-	-	Reserved	0x0
7	R/W	USB_STALL	<p>Stall</p> <p>Setting this bit to 1 causes the chip to generate STALL handshakes under the following conditions:</p> <ul style="list-style-type: none"> The transmit FIFO is enabled and an IN token is received. The receive FIFO is enabled and an OUT token is received. <p>Setting this bit to 1 does not generate a STALL handshake in response to a SETUP token</p>	0x0
6	-	-	Reserved	0x0
5	R/W	USB_ISO	<p>Isochronous</p> <p>When this bit is set to 1, the endpoint is isochronous. This implies that no NAK is sent if the endpoint is not ready but enabled; i.e. If an IN token is received and no data is available in the FIFO to transmit, or if an OUT token is received and the FIFO is full since there is no USB handshake for isochronous transfers.</p>	0x0
4	R/W	USB_EP_EN	<p>Endpoint Enable</p> <p>When this bit is set to 1, the EP[3:0] field is used in address comparison, together with the AD[6:0] field in the FAR register. See Section 36.8 for a description. When cleared to 0, the endpoint does not respond to any token on the USB bus.</p>	0x0
3:0	R/W	USB_EP	<p>Endpoint Address</p> <p>This 4-bit field holds the endpoint address.</p>	0x0

Table 513: USB_RXD2_REG (0x5000186A)

Bit	Mode	Symbol	Description	Reset
15:8	-	-	Reserved	0x0

Table 513: USB_RXD2_REG (0x5000186A)

Bit	Mode	Symbol	Description	Reset
7:0	R	USB_RXFD	Receive FIFO Data Byte See Receive Endpoint FIFO on page 223 for a description of Endpoint FIFO data handling. The firm- ware should expect to read only the packet payload data. The PID and CRC16 are terminated by the receive state machine. In TEST mode this register allow read/write access via the core bus.	0x0

Table 514: USB_RXS2_REG (0x5000186C)

Bit	Mode	Symbol	Description	Reset
15:8	-	-	Reserved	0x0
7	R	USB_RX_ERR	Receive Error When set to 1, this bit indicates a media error, such as bit- stuffing or CRC. If this bit is set to 1, the firmware must flush the respective FIFO.	0x0
6	R	USB_SETUP	Setup This bit indicates that the setup packet has been received. It is cleared when this register is read.	0x0
5	R	USB_TOGGLE_RX	Toggle The function of this bit differs depending on whether ISO (ISO in the EPCn register is set) or non-ISO operation (ISO is reset) is used. For non-ISO operation, a value of 0 indicates that the last successfully received packet had a DATA0 PID, while a value of 1 indicates that this packet had a DATA1 PID. For ISO operation, this bit reflects the LSB of the frame num- ber (FNL0) after a packet was successfully received for this endpoint. This bit is reset to 0 by reading the RXSn register.	0x0
4	R	USB_RX_LAST	Receive Last This bit indicates that an ACK was sent upon completion of a successful receive operation. This bit is cleared to 0 when this register is read.	0x0
3:0	R	USB_RCOUNT	Receive Counter This 4-bit field contains the number of bytes presently in the endpoint receive FIFO. If this number is greater than 15, a value of 15 is actually reported.	0x0

Table 515: USB_RXC2_REG (0x5000186E)

Bit	Mode	Symbol	Description	Reset
15:7	-	-	Reserved	0x0
6:5	R/W	USB_RFWL	Receive FIFO Warning Limit These bits specify how many more bytes can be received to the respective FIFO before an overrun condition occurs. If the number of empty bytes remaining in the FIFO is equal to or less than the selected warning limit, the RXWARN bit in the FWEV register is set to 1. RFWL[1:0] : 00: RFWL disabled 01: Less than 5 bytes remaining in FIFO 10: Less than 9 bytes remaining in FIFO 11: Less than 17 bytes remaining in FIFO	0x0

Table 515: USB_RXC2_REG (0x5000186E)

Bit	Mode	Symbol	Description	Reset
4	-	-	Reserved	0x0
3	R/W	USB_FLUSH	Flush FIFO Writing a 1 to this bit flushes all data from the corresponding receive FIFO, resets the endpoint to Idle state, and resets both the FIFO read and write pointers. If the MAC is currently using the FIFO to receive data, flushing is delayed until after receiving is completed.	0x0
2	R/W	USB_IGN_SETUP	Ignore SETUP Tokens When this bit is set to 1, the endpoint ignores any SETUP tokens directed to its configured address.	0x0
1	-	-	Reserved	0x0
0	R/W	USB_RX_EN	Receive Enable OUT packet cannot be received after every data packet is received, or when a STALL handshake is returned in response to an OUT token. This bit must be written with a 1 to re-enable data reception. SETUP packets can always be received. In the case of back-to-back SETUP packets (for a given endpoint) where a valid SETUP packet has been received with no other intervening non-SETUP tokens, the receive state machine discards the new SETUP packet and returns an ACK handshake. If, for any other reason, the receive state machine cannot accept the SETUP packet, no HANDSHAKE should be generated.	0x0

Table 516: USB_EPC5_REG (0x50001870)

Bit	Mode	Symbol	Description	Reset
15:8	-	-	Reserved	0x0
7	R/W	USB_STALL	Stall Setting this bit to 1 causes the chip to generate STALL handshakes under the following conditions: The transmit FIFO is enabled and an IN token is received. The receive FIFO is enabled and an OUT token is received. Setting this bit to 1 does not generate a STALL handshake in response to a SETUP token	0x0
6	-	-	Reserved	0x0
5	R/W	USB_ISO	Isochronous When this bit is set to 1, the endpoint is isochronous. This implies that no NAK is sent if the endpoint is not ready but enabled; i.e. If an IN token is received and no data is available in the FIFO to transmit, or if an OUT token is received and the FIFO is full since there is no USB handshake for isochronous transfers.	0x0
4	R/W	USB_EP_EN	Endpoint Enable When this bit is set to 1, the EP[3:0] field is used in address comparison, together with the AD[6:0] field in the FAR register. See Section 36.8 for a description. When cleared to 0, the endpoint does not respond to any token on the USB bus.	0x0
3:0	R/W	USB_EP	Endpoint Address This 4-bit field holds the endpoint address.	0x0

Table 517: USB_TXD3_REG (0x50001872)

Bit	Mode	Symbol	Description	Reset
15:8	-	-	Reserved	0x0
7:0	W	USB_TXFD	Transmit FIFO Data Byte See Transmit Endpoint FIFOs on page 222 for a description of endpoint FIFO data handling. The firm- ware is expected to write only the packet payload data. PID and CRC16 are inserted automatically in the transmit data stream. In TEST mode this register allow read/write access via the core bus.	0x0

Table 518: USB_TXS3_REG (0x50001874)

Bit	Mode	Symbol	Description	Reset
15:8	-	-	Reserved	0x0
7	R	USB_TX_URUN	Transmit FIFO Underrun This bit is set to 1, if the transmit FIFO becomes empty dur- ing a transmission, and no new data is written to the FIFO. If so, the Media Access Controller (MAC) forces a bit stuff error followed by an EOP. This bit is cleared to 0, when this regis- ter is read.	0x0
6	R	USB_ACK_STAT	Acknowledge Status This bit is interpreted when TX_DONE is set. It's function dif- fers depending on whether ISO (ISO in the EPCx register is set) or non-ISO operation (ISO is reset) is used. For non-ISO operation, this bit indicates the acknowledge status (from the host) about the ACK for the previously sent packet. This bit itself is set to 1, when an ACK is received; otherwise, it is cleared to 0. For ISO operation, this bit is set if a frame number LSB match (see IGN_ISOMSK bit in the USB_TXCx_REG) occurs, and data was sent in response to an IN token. Other- wise, this bit is cleared to 0, the FIFO is flushed and TX_DONE is set. This bit is also cleared to 0, when this register is read.	0x0
5	R	USB_TX_DONE	Transmission Done When set to 1, this bit indicates that the endpoint responded to a USB packet. Three conditions can cause this bit to be set: A data packet completed transmission in response to an IN token with non-ISO operation. The endpoint sent a STALL handshake in response to an IN token A scheduled ISO frame was transmitted or discarded. This bit is cleared to 0 when this register is read.	0x0
4:0	R	USB_TCOUNT	Transmission Count This 5-bit field holds the number of empty bytes available in the FIFO. If this number is greater than 31, a value of 31 is actually reported.	0x1F

Table 519: USB_TXC3_REG (0x50001876)

Bit	Mode	Symbol	Description	Reset
15:8	-	-	Reserved	0x0

Table 519: USB_TXC3_REG (0x50001876)

Bit	Mode	Symbol	Description	Reset
7	R/W	USB_IGN_ISOMSK	Ignore ISO Mask This bit has an effect only if the endpoint is set to be isochronous. If set to 1, this bit disables locking of specific frame numbers with the alternate function of the TOGGLE bit. Thus data is transmitted upon reception of the next IN token. If cleared to 0, data is only transmitted when FNL0 matches TOGGLE. This bit is cleared to 0 after reset.	0x0
6:5	R/W	USB_TFWL	Transmit FIFO Warning Limit These bits specify how many more bytes can be transmitted from the respective FIFO before an underrun condition occurs. If the number of bytes remaining in the FIFO is equal to or less than the selected warning limit, the TXWARN bit in the FWEV register is set. To avoid interrupts caused by setting this bit while the FIFO is being filled before a transmission begins, TXWARN is only set when transmission from the endpoint is enabled (TX_ENn in the TXCn register is set). TFWL[1:0] : 00: TFWL disabled 01: Less than 5 bytes remaining in FIFO 10: Less than 9 bytes remaining in FIFO 11: Less than 17 bytes remaining in FIFO	0x0
4	R/W	USB_RFF	Refill FIFO Setting the LAST bit to 1 automatically saves the Transmit Read Pointer (TXRP) to a buffer. When the RFF bit is set to 1, the buffered TXRP is reloaded into the TXRP. This allows the user to repeat the last transaction if no ACK was received from the host. If the MAC is currently using the FIFO to transmit, TXRP is reloaded only after the transmission is complete. After reload, this bit is cleared to 0 by hardware.	0x0
3	R/W	USB_FLUSH	Flush FIFO Writing a 1 to this bit flushes all data from the corresponding transmit FIFO, resets the endpoint to Idle state, and clears both the FIFO read and write pointers. If the MAC is currently using the FIFO to transmit, data is flushed after the transmission is complete. After data flushing, this bit is cleared to 0 by hardware.	0x0
2	R/W	USB_TOGGLE_TX	Toggle The function of this bit differs depending on whether ISO (ISO bit in the EPCn register is set to 1) or non-ISO operation (ISO bit is cleared to 0) is used. For non-ISO operation, it specifies the PID used when transmitting the packet. A value of 0 causes a DATA0 PID to be generated, while a value of 1 causes a DATA1 PID to be generated. For ISO operation, this bit and the LSB of the frame counter (FNL0) act as a mask for the TX_EN bit to allow pre-queuing of packets to specific frame numbers; i.e. transmission is enabled only if bit 0 in the FNL register is set to TOGGLE. If an IN token is not received while this condition is true, the contents of the FIFO are flushed with the next SOF. If the endpoint is set to ISO, data is always transferred with a DATA0 PID.	0x0

Table 519: USB_TXC3_REG (0x50001876)

Bit	Mode	Symbol	Description	Reset
1	R/W	USB_LAST	<p>Last Byte</p> <p>Setting this bit to 1 indicates that the entire packet has been written into the FIFO. This is used especially for streaming data to the FIFO while the actual transmission occurs. If the LAST bit is not set to 1 and the transmit FIFO becomes empty during a transmission, a stuff error followed by an EOP is forced on the bus. Zero length packets are indicated by setting this bit without writing any data to the FIFO. The transmit state machine transmits the payload data, CRC16 and the EOP signal before clearing this bit.</p>	0x0
0	R/W	USB_TX_EN	<p>Transmission Enable</p> <p>This bit enables data transmission from the FIFO. It is cleared to 0 by hardware after transmitting a single packet or after a STALL handshake in response to an IN token. It must be set to 1 by firmware to start packet transmission.</p>	0x0

Table 520: USB_EPC6_REG (0x50001878)

Bit	Mode	Symbol	Description	Reset
15:8	-	-	Reserved	0x0
7	R/W	USB_STALL	<p>Stall</p> <p>Setting this bit to 1 causes the chip to generate STALL handshakes under the following conditions:</p> <ul style="list-style-type: none"> The transmit FIFO is enabled and an IN token is received. The receive FIFO is enabled and an OUT token is received. <p>Setting this bit to 1 does not generate a STALL handshake in response to a SETUP token</p>	0x0
6	-	-	Reserved	0x0
5	R/W	USB_ISO	<p>Isochronous</p> <p>When this bit is set to 1, the endpoint is isochronous. This implies that no NAK is sent if the endpoint is not ready but enabled; i.e. If an IN token is received and no data is available in the FIFO to transmit, or if an OUT token is received and the FIFO is full since there is no USB handshake for isochronous transfers.</p>	0x0
4	R/W	USB_EP_EN	<p>Endpoint Enable</p> <p>When this bit is set to 1, the EP[3:0] field is used in address comparison, together with the AD[6:0] field in the FAR register. See Section 36.8 for a description. When cleared to 0, the endpoint does not respond to any token on the USB bus.</p>	0x0
3:0	R/W	USB_EP	<p>Endpoint Address</p> <p>This 4-bit field holds the endpoint address.</p>	0x0

Table 521: USB_RXD3_REG (0x5000187A)

Bit	Mode	Symbol	Description	Reset
15:8	-	-	Reserved	0x0

Table 521: USB_RXD3_REG (0x5000187A)

Bit	Mode	Symbol	Description	Reset
7:0	R	USB_RXFD	Receive FIFO Data Byte See Receive Endpoint FIFO on page 223 for a description of Endpoint FIFO data handling. The firmware should expect to read only the packet payload data. The PID and CRC16 are terminated by the receive state machine. In TEST mode this register allow read/write access via the core bus.	0x0

Table 522: USB_RXS3_REG (0x5000187C)

Bit	Mode	Symbol	Description	Reset
15:8	-	-	Reserved	0x0
7	R	USB_RX_ERR	Receive Error When set to 1, this bit indicates a media error, such as bit-stuffing or CRC. If this bit is set to 1, the firmware must flush the respective FIFO.	0x0
6	R	USB_SETUP	Setup This bit indicates that the setup packet has been received. It is cleared when this register is read.	0x0
5	R	USB_TOGGLE_RX	Toggle The function of this bit differs depending on whether ISO (ISO in the EPCn register is set) or non-ISO operation (ISO is reset) is used. For non-ISO operation, a value of 0 indicates that the last successfully received packet had a DATA0 PID, while a value of 1 indicates that this packet had a DATA1 PID. For ISO operation, this bit reflects the LSB of the frame number (FNL0) after a packet was successfully received for this endpoint. This bit is reset to 0 by reading the RXSn register.	0x0
4	R	USB_RX_LAST	Receive Last This bit indicates that an ACK was sent upon completion of a successful receive operation. This bit is cleared to 0 when this register is read.	0x0
3:0	R	USB_RCOUNT	Receive Counter This 4-bit field contains the number of bytes presently in the endpoint receive FIFO. If this number is greater than 15, a value of 15 is actually reported.	0x0

Table 523: USB_RXC3_REG (0x5000187E)

Bit	Mode	Symbol	Description	Reset
15:7	-	-	Reserved	0x0
6:5	R/W	USB_RFWL	Receive FIFO Warning Limit These bits specify how many more bytes can be received to the respective FIFO before an overrun condition occurs. If the number of empty bytes remaining in the FIFO is equal to or less than the selected warning limit, the RXWARN bit in the FWEV register is set to 1. RFWL[1:0] : 00: RFWL disabled 01: Less than 5 bytes remaining in FIFO 10: Less than 9 bytes remaining in FIFO 11: Less than 17 bytes remaining in FIFO	0x0

Table 523: USB_RXC3_REG (0x5000187E)

Bit	Mode	Symbol	Description	Reset
4	-	-	Reserved	0x0
3	R/W	USB_FLUSH	Flush FIFO Writing a 1 to this bit flushes all data from the corresponding receive FIFO, resets the endpoint to Idle state, and resets both the FIFO read and write pointers. If the MAC is currently using the FIFO to receive data, flushing is delayed until after receiving is completed.	0x0
2	R/W	USB_IGN_SETUP	Ignore SETUP Tokens When this bit is set to 1, the endpoint ignores any SETUP tokens directed to its configured address.	0x0
1	-	-	Reserved	0x0
0	R/W	USB_RX_EN	Receive Enable OUT packet cannot be received after every data packet is received, or when a STALL handshake is returned in response to an OUT token. This bit must be written with a 1 to re-enable data reception. SETUP packets can always be received. In the case of back-to-back SETUP packets (for a given endpoint) where a valid SETUP packet has been received with no other intervening non-SETUP tokens, the receive state machine discards the new SETUP packet and returns an ACK handshake. If, for any other reason, the receive state machine cannot accept the SETUP packet, no HANDSHAKE should be generated.	0x0

Table 524: USB_DMA_CTRL_REG (0x500018D0)

Bit	Mode	Symbol	Description	Reset
6	R/W	USB_DMA_EN	0 = USB DMA control off. (Normal operation) 1 = USB_DMA on. DMA channels 0 and 1 are connected by USB Endpoint according bits USB_DMA_TX and USB_DMA_RX	0x0
5:3	R/W	USB_DMA_TX	000 = DMA channels 1 is connected Tx USB Endpoint 1 001 = DMA channels 1 is connected Tx USB Endpoint 3 010 = DMA channels 1 is connected Tx USB Endpoint 5 100, 1xx = Reserved	0x0
2:0	R/W	USB_DMA_RX	000 = DMA channels 0 is connected Rx USB Endpoint 2 001 = DMA channels 0 is connected Rx USB Endpoint 4 010 = DMA channels 0 is connected Rx USB Endpoint 6 100, 1xx = Reserved	0x0

Table 525: USB_CHARGER_CTRL_REG (0x500018D4)

Bit	Mode	Symbol	Description	Reset
15:6	-	-	Reserved	0x0
5	R/W	IDM_SINK_ON	0 = Disable 1 = Enable the Idm_sink to USBm	0x0
4	R/W	IDP_SINK_ON	0 = Disable 1 = Enable the Idp_sink to USBp	0x0
3	R/W	VDM_SRC_ON	0 = Disable 1 = Enable Vdm_src to USBm and USB_DCP_DET status bit.	0x0
2	R/W	VDP_SRC_ON	0 = Disable 1 = Enable the Vdp_src to USB_CHG_DET status bit.	0x0

Table 525: USB_CHARGER_CTRL_REG (0x500018D4)

Bit	Mode	Symbol	Description	Reset
1	R/W	IDP_SRC_ON	0 = Disable 1 = Enable the Idp_src and Rdm_dwn.	0x0
0	R/W	USB_CHARGE_ON	0 = Disable USB charger detect circuit. 1 = Enable USB charger detect circuit.	0x0

Table 526: USB_CHARGER_STAT_REG (0x500018D6)

Bit	Mode	Symbol	Description	Reset
15:6	-	-	Reserved	0x0
5	R	USB_DM_VAL2	0 = USBm < 2.3V 1 = USBm > 2.5V	0x0
4	R	USB_DP_VAL2	0: USBp < 2.3V 1: USBp > 2.5V	0x0
3	R	USB_DM_VAL	0 = USBm < 0.8V 1 = USBm > 1.5V (PS2 or Proprietary Charger)	0x0
2	R	USB_DP_VAL	0 = USBp < 0.8V 1 = USBp > 1.5V	0x0
1	R	USB_CHG_DET	0 = Standard downstream or nothing connected. 1 = Charging Downstream Port (CDP) or Dedicated Charging.	0x0
0	R	USB_DCP_DET	0 = Charging downstream port is detected. 1 = Dedicated charger is detected. Control bit VDM_SRC_ON must be set to validate this status bit. Note: This register shows the actual status.	0x0

37.16 GPADC REGISTER FILE

Table 527: Register map GPADC

Address	Port	Description
0x50001900	GP_ADC_CTRL_REG	General Purpose ADC Control Register
0x50001902	GP_ADC_CTRL2_REG	General Purpose ADC Second Control Register
0x50001904	GP_ADC_CTRL3_REG	General Purpose ADC Third Control Register
0x50001906	GP_ADC_OFFP_REG	General Purpose ADC Positive Offset Register
0x50001908	GP_ADC_OFFN_REG	General Purpose ADC Negative Offset Register
0x5000190A	GP_ADC_CLEAR_INT_REG	General Purpose ADC Clear Interrupt Register
0x5000190C	GP_ADC_RESULT_REG	General Purpose ADC Result Register

Table 528: GP_ADC_CTRL_REG (0x50001900)

Bit	Mode	Symbol	Description	Reset
15	R/W	GP_ADC_LDO_ZERO	1: Samples and disconnects VREF, should be refreshed frequently. Note that the LDO consumes power when bit is set.	0x0
14	R/W	GP_ADC_CHOP	0: Chopper mode off 1: Chopper mode enabled. Takes two samples with opposite GP_ADC_SIGN to cancel the internal offset voltage of the ADC; Highly recommended for DC-measurements.	0x0
13	R/W	GP_ADC_SIGN	0: Default 1: Conversion with opposite sign at input and output to cancel out the internal offset of the ADC and low-frequency	0x0
12:8	R/W	GP_ADC_SEL	ADC input selection. If GP_ADC_SE = 1 (single ended mode): 0: P1[2] 1: P1[4] 2: P1[3] 3: P0[7] 4: AVS 5: Internal VDD_REF (used for offset calibration) 6: VDCDC (see DCDC_TEST_0_REG.DCDC_OUTPUT_MONITOR for more information; GP_ADC_ATT3X scaler automatically selected) 7: V33 (GP_ADC_ATT3X scaler automatically selected) 8: V33 (GP_ADC_ATT3X scaler automatically selected) 9: VBAT (5V to 1.2V scaler selected) 16: P0[6] 17: P1[0] 18: P1[5] 19: P2[4] All other combinations are reserved. If GP_ADC_SE = 0 (differential mode): 0: P1[2] vs P1[4] All other combinations are P1[3] vs P0[7].	0x0
7	R/W	GP_ADC_MUTE	0: Normal operation 1: Mute ADC input. Takes sample at mid-scale (to determine the internal offset and/or noise of the ADC with regards to VDD_REF which is also sampled by the ADC).	0x0
6	R/W	GP_ADC_SE	0: Differential mode 1: Single ended mode	0x0
5	R/W	GP_ADC_MINT	0: Disable (mask) GP_ADC_INT. 1: Enable GP_ADC_INT to ICU.	0x0

Table 528: GP_ADC_CTRL_REG (0x50001900)

Bit	Mode	Symbol	Description	Reset
4	R	GP_ADC_INT	1: AD conversion ready and has generated an interrupt. Must be cleared by writing any value to GP_ADC_CLEAR_INT_REG.	0x0
3	R/W	GP_ADC_CLK_SEL	0: Internal high-speed ADC clock used (recommended). 1: Digital clock used (ADC_CLK).	0x0
2	R/W	GP_ADC_CONT	0: Manual ADC mode, a single result will be generated after setting the GP_ADC_START bit. 1: Continuous ADC mode, new ADC results will be constantly stored in GP_ADC_RESULT_REG. Still GP_ADC_START has to be set to start the execution. The time between conversions is configurable with GP_ADC_INTERVAL.	0x0
1	R/W	GP_ADC_START	0: ADC conversion ready. 1: If a 1 is written, the ADC starts a conversion. After the conversion this bit will be set to 0 and the GP_ADC_INT bit will be set. It is not allowed to write this bit while it is not (yet) zero.	0x0
0	R/W	GP_ADC_EN	0: LDO is off and ADC is disabled.. 1: LDO is turned on and afterwards the ADC is enabled.	0x0

Table 529: GP_ADC_CTRL2_REG (0x50001902)

Bit	Mode	Symbol	Description	Reset
15:12	R/W	GP_ADC_STORE_DEL	0: Data is stored after handshake synchronisation 1: Data is stored two ADC_CLK cycles after internal start trigger 15: Data is stored sixteen ADC_CLK cycles after internal start trigger	0x0
11:8	R/W	GP_ADC_SMPL_TIME	0: The sample time (switch is closed) is one ADC_CLK cycle 1: The sample time is 1*32 ADC_CLK cycles 2: The sample time is 2*32 ADC_CLK cycles 15: The sample time is 15*32 ADC_CLK cycles	0x0
7:5	R/W	GP_ADC_CONV_NS	0: 1 sample is taken or 2 in case ADC_CHOP is active. 1: 2 samples are taken. 2: 4 samples are taken. 7: 128 samples are taken.	0x0
4	-	-	Reserved	0x0
3	R/W	GP_ADC_DMA_EN	0: DMA functionality disabled 1: DMA functionality enabled	0x0
2	R/W	GP_ADC_I20U	1: Adds 20uA constant load current at the ADC LDO to minimize ripple on the reference voltage of the ADC.	0x0
1	R/W	GP_ADC_IDYN	1: Enables dynamic load current at the ADC LDO to minimize ripple on the reference voltage of the ADC.	0x0
0	R/W	GP_ADC_ATT3X	0: Input voltages up to 1.2V allowed. 1: Input voltages up to 3.6V allowed by enabling 3x attenuator. (if ADC_SEL=7 or 8, this bit is automatically set to 1) Enabling the attenuator requires a longer sampling time.	0x0

Table 530: GP_ADC_CTRL3_REG (0x50001904)

Bit	Mode	Symbol	Description	Reset
15:8	R/W	GP_ADC_INTERVAL	Defines the interval between two ADC conversions in case GP_ADC_CONT is set. 0: No extra delay between two conversions. 1: 1.024ms interval between two conversions. 2: 2.048ms interval between two conversions. 255: 261.12ms interval between two conversions.	0x0
7:0	R/W	GP_ADC_EN_DEL	Defines the delay for enabling the ADC after enabling the LDO. 0: Not allowed 1: 32x ADC_CLK period. n: n*32x ADC_CLK period.	0x40

Table 531: GP_ADC_OFFP_REG (0x50001906)

Bit	Mode	Symbol	Description	Reset
15:10	-	-	Reserved	0x0
9:0	R/W	GP_ADC_OFFP	Offset adjust of 'positive' array of ADC-network (effective if "GP_ADC_SE=0", or "GP_ADC_SE=1 AND GP_ADC_SIGN=0")	0x200

Table 532: GP_ADC_OFFN_REG (0x50001908)

Bit	Mode	Symbol	Description	Reset
15:10	-	-	Reserved	0x0
9:0	R/W	GP_ADC_OFFN	Offset adjust of 'negative' array of ADC-network (effective if "GP_ADC_SE=0", or "GP_ADC_SE=1 AND GP_ADC_SIGN=1")	0x200

Table 533: GP_ADC_CLEAR_INT_REG (0x5000190A)

Bit	Mode	Symbol	Description	Reset
15:0	R0/W	GP_ADC_CLR_INT	Writing any value to this register will clear the ADC_INT interrupt. Reading returns 0.	0x0

Table 534: GP_ADC_RESULT_REG (0x5000190C)

Bit	Mode	Symbol	Description	Reset
15:0	R	GP_ADC_VAL	Returns the 10 up to 16 bits linear value of the last AD conversion. The upper 10 bits are always valid, the lower 6 bits are only valid in case oversampling has been applied. Two samples results in one extra bit and 64 samples results in six extra bits.	0x0

37.17 QUADRATURE DECODER REGISTER FILE

Table 535: Register map Quadrature Decoder

Address	Port	Description
0x50001A00	QDEC_CTRL_REG	Quad decoder control register
0x50001A02	QDEC_XCNT_REG	Counter value of the X Axis
0x50001A04	QDEC_YCNT_REG	Counter value of the Y Axis
0x50001A06	QDEC_ZCNT_REG	Counter value of the Z Axis
0x50001A08	QDEC_CLOCKDIV_REG	Quad decoder clock divider register

Table 536: QDEC_CTRL_REG (0x50001A00)

Bit	Mode	Symbol	Description	Reset
15:13	-	-	Reserved	0x0
12	R/W	CHZ_PORT_EN	'1': Enable channel	0x0
11	R/W	CHY_PORT_EN	'1': Enable channel	0x0
10	R/W	CHX_PORT_EN	'1': Enable channel	0x0
9:3	R/W	QD_IRQ_THRES	The number of events on either counter (X or Y or Z) that need to be reached before an interrupt is generated. If 0 is written, then threshold is considered to be 1.	0x2
2	R	QD_IRQ_STATUS	Interrupt Status. If 1 an interrupt has occurred.	0x0
1	R/W	QD_IRQ_CLR	Writing 1 to this bit clears the interrupt. This bit is auto-cleared	0x0
0	R/W	QD_IRQ_MASK	0: interrupt is masked 1: interrupt is enabled	0x0

Table 537: QDEC_XCNT_REG (0x50001A02)

Bit	Mode	Symbol	Description	Reset
15:0	R	X_COUNTER	Contains a signed value of the events. Zero when channel is disabled	0x0

Table 538: QDEC_YCNT_REG (0x50001A04)

Bit	Mode	Symbol	Description	Reset
15:0	R	Y_COUNTER	Contains a signed value of the events. Zero when channel is disabled	0x0

Table 539: QDEC_ZCNT_REG (0x50001A06)

Bit	Mode	Symbol	Description	Reset
15:0	R	Z_COUNTER	Contains a signed value of the events. Zero when channel is disabled	0

Table 540: QDEC_CLOCKDIV_REG (0x50001A08)

Bit	Mode	Symbol	Description	Reset
9:0	R/W	CLOCK_DIVIDER	Contains the number of the input clock cycles minus one, that are required to generate one logic clock cycle.	0x0

37.18 ANAMISC REGISTER FILE

Table 541: Register map ANAMISC

Address	Port	Description
0x50001B08	CHARGER_CTRL1_REG	Charger control register 1
0x50001B0A	CHARGER_CTRL2_REG	Charger control register 2
0x50001B0C	CHARGER_STATUS_REG	Charger status and trimming register
0x50001B40	SOC_CTRL1_REG	Fuel Gauge Control register 1
0x50001B42	SOC_CTRL2_REG	Fuel Gauge Control register 2
0x50001B44	SOC_CTRL3_REG	Fuel Gauge Control register 3
0x50001B46	SOC_ADD2CH_REG	Fuel Gauge manually add extra charge to SOC_CHARGE_CNTRx_REG
0x50001B48	SOC_CHARGE_CNTR1_REG	Fuel Gauge Charge counter bits 15-0
0x50001B4A	SOC_CHARGE_CNTR2_REG	Fuel Gauge Charge counter bits 31-16
0x50001B4C	SOC_CHARGE_CNTR3_REG	Fuel Gauge Charge counter bits 39-32
0x50001B50	SOC_CHARGE_AVG_REG	Fuel Gauge Average charge counter
0x50001B52	SOC_STATUS_REG	Fuel Gauge Status register
0x50001B54	SOC_EXT_IN_REG	Fuel Gauge input test register
0x50001B56	SOC_EXT_OUT_REG	Fuel Gauge output test register
0x50001B60	CLK_REF_SEL_REG	Select clock for oscillator calibration
0x50001B62	CLK_REF_CNT_REG	Count value for oscillator calibration
0x50001B64	CLK_REF_VAL_L_REG	DIVN reference cycles, lower 16 bits
0x50001B66	CLK_REF_VAL_H_REG	DIVN reference cycles, upper 16 bits

Table 542: CHARGER_CTRL1_REG (0x50001B08)

Bit	Mode	Symbol	Description	Reset
15	-	-	Reserved	0x0
14	R/W	DIE_TEMP_DISABLE	0: Die temperature protection enabled: charger will be disabled when die temp exceeds value set in DIE_TEMP_SET 1: Die temperature protection disabled: testmode, use only in agreement with Dialog	0x0
13:12	R/W	DIE_TEMP_SET	Die temperature protection level. Charging will be automatically disabled if set level is exceeded and resumed when temperature has dropped few degrees below set level. 00: 0°C (do not use, for test only) 01: 50°C (do not use, for test only) 10: 80°C (default) 11: 100°C	0x2

Table 542: CHARGER_CTRL1_REG (0x50001B08)

Bit	Mode	Symbol	Description	Reset
11:8	R/W	CHARGE_CUR	Constant Current levels (typical values) 0000: 5 mA 0001: 10 mA 0010: 30 mA 0011: 45 mA 0100: 60 mA 0101: 90 mA 0110: 120 mA 0111: 150 mA 1000: 180 mA 1001: 210 mA 1010: 270 mA 1011: 300 mA 1100: 350 mA 1101: 400 mA	0x0
7	R/W	NTC_LOW_DISABLE	0: Normal operation: voltage level higher than 7/8 VDD_USB will disable the charger 1: NTC low temp limit disabled: use if trickle charging below the minimum temperature is required	0x0
6	R/W	NTC_DISABLE	0: Charger NTC protection enabled 1: Charger NTC protection disable	0x0
5	R/W	CHARGE_ON	0: Charger in powerdown 1: Charger enabled	0x0
4:0	R/W	CHARGE_LEVEL	Constant Voltage Levels 00000: 3.00V (reset) 00001: 3.40V (e.g. 2xNiMH) 00010: 3.50V 00011: 3.60V (e.g. Li-phosphate) 00100: 3.74V 00101: 3.86V 00110: 4.00V 00111: 4.05V 01000: 4.10V 01001: 4.15V 01010: 4.20V (e.g. Li-Co, Li-Mn, NMC) 01011: 4.25V 01100: 4.30V 01101: 4.35V 01110: 4.40V 01111: 4.50V 10000: 4.60V 10001: 4.90V e.g. 3xNiMH 10010: 5.00V	0x0

Table 543: CHARGER_CTRL2_REG (0x50001B0A)

Bit	Mode	Symbol	Description	Reset
15:13	R/W	CHARGER_TEST	Signals are mapped on SPDIF pin. Also set ANA_TEST_REG[ANA_TESTBUS_TO_ADCPIN] = 1 000: normal mode (no test selected) 001: Vpstat (temperature sensor) [1.4V max] 010: Vbat_sense after divider [1.2V] 011: Current loop output [0 to vsupply] 100: Voltage loop output [0 to vsupply] 101: I meas or Iref/10 110: Icharge reduced by 26.6 111: reserved	0x0
12:8	R/W	CURRENT_OFFSET_TRIM	do not change, for test purpose only	0xF
7:4	R/W	CHARGER_VFLOAT_ADJ	Independent adjustment for the charge level. Adjust range is +/- 1.8%. The 4 bits adjustment is in two's complement.	0x0
3:0	R/W	CURRENT_GAIN_TRIM	do not change, for test purpose only	0x7

Table 544: CHARGER_STATUS_REG (0x50001B0C)

Bit	Mode	Symbol	Description	Reset
15:8	-	-	Reserved	0x0
6	R	CHARGER_TMODE_PROT	0: Diatemp below DIE_TEMP_SET level. Normal operation 1: Diatemp above DIE_TEMP_SET level. Charging is disabled	0x0
5	R	CHARGER_BATTEMP_HIGH	0: Battery pack temperature 'ok' or 'too low' (voltage level on NTC pin above 1/2 VDD_USB) 1: Battery pack temperature 'too high' (voltage level on NTC pin below 1/2 VDD_USB)	0x0
4	R	CHARGER_BATTEMP_OK	0: Battery pack temperature 'too low' or 'too high' (voltage level on NTC pin below 1/2 or above 7/8 VDD_USB) 1: Battery pack temperature 'ok' (voltage level on NTC pin between 1/2 and 7/8 VDD_USB)	0x0
3	R	CHARGER_BATTEMP_LOW	0: Battery pack temperature 'ok' or 'too high' (voltage level on NTC pin below 7/8 VDD_USB) 1: Battery pack temperature 'too low' (voltage level on NTC pin above than 7/8 VDD_USB)	0x0
2	R	END_OF_CHARGE	0: Actual charge current is between 10...100% of set CHARGE_CUR (or CHARGE_ON=0) 1: Actual charge current <10% of set CHARGE_CUR	0x0
1	R	CHARGER_CV_MODE	0: voltage loop not in regulation (or charger is off) 1: constant voltage mode active, voltage loop in regulation.	0x0
0	R	CHARGER_CC_MODE	0: current loop not in regulation (or charger is off) 1: constant current mode active, current loop in regulation.	0x0

Table 545: SOC_CTRL1_REG (0x50001B40)

Bit	Mode	Symbol	Description	Reset
15:14	R/W	SOC_CINT	Integrator capacitor scaler 0: Cint = 1 pF 1: Cint = 2 pF 2: Cint = 4 pF 3: Cint = 8 pF (=default)	0x3

Table 545: SOC_CTRL1_REG (0x50001B40)

Bit	Mode	Symbol	Description	Reset
13:12	R/W	SOC_BIAS	Current DAC scaler 0: I _{bias} = 2 uA 1: I _{bias} = 1 uA (=default) 2: I _{bias} = 0.5 uA 3: I _{bias} = 0.25 uA	0x1
11:9	R/W	SOC_CLK	SOC Sample frequency 0: automatic mode 1: fs = 18 kHz 2: fs = 36 kHz 3: fs = 72 kHz 4: fs = 144 kHz (=default) 5: fs = 288 kHz 6: fs = 576 kHz 7: fs = 1152 kHz	0x4
8	R/W	SOC_LPF	0: low-pass filter at integrator inputs disabled 1: Enables a low-pass filter at the integrator inputs	0x0
7:6	R/W	SOC_IDAC	Scales the current DAC (I _{bias} : default=1uA) 0: I _{dac} =0.25*I _{bias} 1: I _{dac} =0.5*I _{bias} 2: I _{dac} =I _{bias} (=default) 3: I _{dac} =2*I _{bias}	0x2
5	R/W	SOC_SIGN	Defines the sign of the charge converter input and output to perform a chopper function to eliminate offset voltage (see also SOC_CHOP and 'sign' on output pin) 0: non-inverted inputs and outputs 1: inverted inputs and outputs	0x0
4	R/W	SOC_GPIO	Reserved (not yet implemented): switches the SOC-inputs to the GPIO pins	0x0
3	R/W	SOC_MUTE	0: Normal operation 1: Connect the input voltage to 0V	0x0
2	R/W	SOC_RESET_AVG	1: Reset the SOC_CHARGE_AVG_REG to the last value of SOC_CHARGE_CNTRx_REG	0x0
1	R/W	SOC_RESET_CHARGE	1: Reset CHARGE_CNTR_REG	0x0
0	R/W	SOC_ENABLE	0: SOC analog circuits off. CHARGE_CNTRx_REG can still be written for a manual update. See SOC_ADD2CH_REG 1: SOC analog circuits enabled	0x0

Table 546: SOC_CTRL2_REG (0x50001B42)

Bit	Mode	Symbol	Description	Reset
15	R/W	SOC_DYNAVG	if HIGH then 'weight' of Moving Average is forced to 1 if the converter detects significant input change (if dcharge > 4*delta_c, or high_limit, or low_limit)	0x0
14:12	R/W	SOC_MAW	Moving Average Weight factor charge_avg(n) = (weight*charge_avg(n-1) + charge(n)) / (weight+1) where: weight = 2^(soc_maw)	0x7
11	R/W	SOC_CMIREG_ENABLE	SOC_CMIREG enable	0x0

Table 546: SOC_CTRL2_REG (0x50001B42)

Bit	Mode	Symbol	Description	Reset
10:8	R/W	SOC_CHOP	Chopping control 0: 'external' chopping control with 'soc_sign'-input 1: chop each 2^1 *scycle fs-periods 2: chop each 2^2 *scycle fs-periods .. 7: chop each 2^7 *scycle fs-periods.	0x7
7:6	R/W	SOC_ICM	adds a common-mode current to Idac to increase the common-mode input-level of the integrator. The common-mode input level is equal to $(Idac+Icm)*Rvi$; 0: $Icm=0$; 1: $Icm=1*Ibias$ (=default); 2: $Icm=2*Ibias$; 3: $Icm=4*Ibias$	0x1
5	R/W	SOC_DCYCLE	Cycle the current divider segments of Idac 0: no cycling 1: cycle each scycle fs-periods	0x1
4:2	R/W	SOC_SCYCLE	Cycle current segments (8 segments) of Idac 0: no cycling 1: cycle each fs-period 2: cycle each 2 fs-periods .. 7: cycle each 7 fs-periods	0x2
1:0	R/W	SOC_RVI	Voltage-to-current resistor scaler 0: $Rvi = 25\text{ k}$ 1: $Rvi = 50\text{ k}$ 2: $Rvi = 100\text{ k}$ (= default) 3: $Rvi = 200\text{ k}$	0x2

Table 547: SOC_CTRL3_REG (0x50001B44)

Bit	Mode	Symbol	Description	Reset
15:6	-	-	Reserved	0x0
5:4	R/W	SOC_VCFMI	Common Input Voltage target of regulator (see SOC_CMIREG_ENABLE) 0: 50 mV 1: 100 mV 2: 150 mV 3: 200 mV	0x1
3	R/W	SOC_DYNHYS	Reserved. (To be implemented) Hysteresis of the comparator which detects if the integrator voltage is rising or falling	0x0
2	R/W	SOC_DYNTARG	Reserved. (To be implemented) 0: $Vint_target = 0V$ 1: $Vint_target$ tracks the 2 MSB's of the charge register)	0x0
1:0	R/W	SOC_VSAT	Trigger level of the high-limit and low-limit comparators. 0: $low_limit = -50mV$; $high_limit = +50mV$ 1: $low_limit = -100mV$; $high_limit = +100mV$ (=default) 2: $low_limit = -200mV$; $high_limit = +200mV$ 3: $low_limit = -400mV$; $high_limit = +400mV$	0x1

Table 548: SOC_ADD2CH_REG (0x50001B46)

Bit	Mode	Symbol	Description	Reset
15:0	R/W	SOC_ADD2CH	Extra charge to be added to the SOC_CHARGE_CNTRx_REG per sample period (9-bit + sign + 6 fractional bits)	0x0

Table 549: SOC_CHARGE_CNTR1_REG (0x50001B48)

Bit	Mode	Symbol	Description	Reset
15:0	R	CHARGE_CNT1	Sum of the charge-values per sampling period; (bits15:0) The absolute full-scale charge value is 6-bits, At full scale charge current it takes 2 ²⁶ sampling periods until overflow of the charge_cnt register after a reset_charge event. At fs=144kHz (=default) this will happen after 33 hours At fs=1.152MHz After 10 hours	0x0

Table 550: SOC_CHARGE_CNTR2_REG (0x50001B4A)

Bit	Mode	Symbol	Description	Reset
15:0	R	CHARGE_CNT2	Sum of the charge-values per sampling period; (bits23:16)	0x0

Table 551: SOC_CHARGE_CNTR3_REG (0x50001B4C)

Bit	Mode	Symbol	Description	Reset
15:8	-	-	Reserved	0x0
7:0	R	CHARGE_CNT3	Sum of the charge-values per sampling period; (bits39:24)	0x0

Table 552: SOC_CHARGE_AVG_REG (0x50001B50)

Bit	Mode	Symbol	Description	Reset
15:0	R	CHARGE_AVG	Average of 'charge' current (9-bit + sign and 6 fractional bits)	0x0

Table 553: SOC_STATUS_REG (0x50001B52)

Bit	Mode	Symbol	Description	Reset
15:2	-	-	Reserved	0x0
1	R	SOC_INT_LOCKED	0: Normal Operation 1: Integrator is pushed over high or low limit. Returns to '0' if the converter runs for more than 2 sequential sampling periods in a 'safe' region (dcharge < 2*delta_c)	0x0
0	R	SOC_INT_OVERLOAD	0: Normal Operation 1: Integrator exceeds high or low limit with full-scale IDAC (charge) for more than 3 sequential sampling periods	0x0

Table 554: SOC_EXT_IN_REG (0x50001B54)

Bit	Mode	Symbol	Description	Reset
15	R/W	SOC_EXT_IDAC_EN	1: Enable 'external' control of Idac	0x0
14	R/W	SOC_EXT_SCYCLE_EN	1: Enable 'external' control of scycle	0x0
13:11	R/W	SOC_NR_SCYCLE	Number of the scycle	0x0

Table 554: SOC_EXT_IN_REG (0x50001B54)

Bit	Mode	Symbol	Description	Reset
10	R/W	SOC_RDAC_DIS	0: Disables the resistor divider DAC. The Idac has 6-bits (plus sign) 1: Enables the resistor divider DAC. The Idac has 9-bits (plus sign)	0x0
9	R/W	SOC_IDAC_SIGN	0: SOC_IDAC_VAL is positive 1: SOC_IDAC_VAL is negative	0x0
8:0	R/W	SOC_IDAC_VAL	Controls the current for the DAC. 0: $0/512 * SOC_IDAC$ N: $N/512 * SOC_IDAC$	0x0

Table 555: SOC_EXT_OUT_REG (0x50001B56)

Bit	Mode	Symbol	Description	Reset
15:9	-	-	Reserved	0x0
8	R	SOC_CTRL_EVENT	Controller event	0x0
7:4	R	SOC_STATE	Controller state	0x0
3	R	SOC_RISING_COMP	Rising comparator output	0x0
2	R	SOC_POS_COMP	Positive comparator output	0x0
1	R	SOC_LOWLIM_COMP	Low_limit comparator output	0x0
0	R	SOC_HIGH_LIM	High_limit comparator output	0x0

Table 556: CLK_REF_SEL_REG (0x50001B60)

Bit	Mode	Symbol	Description	Reset
15:3	-	-	Reserved	0x0
2	R/W	REF_CAL_START	Writing a '1' starts a calibration. This bit is cleared when calibration is finished, and CLK_REF_VAL is ready.	0x0
1:0	R/W	REF_CLK_SEL	Select clock input for calibration: 0x0 : 32KHz RC oscillator clock 0x1 : 16MHz RC oscillator clock 0x2 : 32KHz XTAL clock 0x3 : 11.7KHz RCX oscillator clock	0x0

Table 557: CLK_REF_CNT_REG (0x50001B62)

Bit	Mode	Symbol	Description	Reset
15:0	R/W	REF_CNT_VAL	Indicates the calibration time, with a decrement counter to 1.	0x0

Table 558: CLK_REF_VAL_L_REG (0x50001B64)

Bit	Mode	Symbol	Description	Reset
15:0	R	XTAL_CNT_VAL	Returns the lower 16 bits of DIVN clock cycles counted during the calibration time, defined with REF_CNT_VAL	0x0

Table 559: CLK_REF_VAL_H_REG (0x50001B66)

Bit	Mode	Symbol	Description	Reset
15:0	R	XTAL_CNT_VAL	Returns the upper 16 bits of DIVN clock cycles counted during the calibration time, defined with REF_CNT_VAL	0x0

37.19 CRG REGISTER FILE

Table 560: Register map CRG

Address	Port	Description
0x50001C04	CLK_PER_REG	Peripheral divider register
0x50001C40	PCM_DIV_REG	PCM divider and enables
0x50001C42	PCM_FDIV_REG	PCM fractional division register
0x50001C44	PDM_DIV_REG	PDM divider and enables
0x50001C46	SRC_DIV_REG	SRC divider and enables
0x50001C4A	USBPAD_REG	USB pads control register

Table 561: CLK_PER_REG (0x50001C04)

Bit	Mode	Symbol	Description	Reset
11	R/W	ADC_CLK_SEL	Selects the clock source 1 = DIV1 clock 0 = DIVN clock	0x0
10	R/W	KBSCAN_CLK_SEL	Selects the clock source 1 = DIV1 clock 0 = DIVN clock	0x0
9	R/W	I2C_CLK_SEL	Selects the clock source 1 = DIV1 clock 0 = DIVN clock	0x0
8	R/W	SPI_CLK_SEL	Selects the clock source 1 = DIV1 clock 0 = DIVN clock	0x0
7:6	-	-	Reserved	0x0
5	R/W	KBSCAN_ENABLE	Enables the clock	0x0
4	R/W	IR_CLK_ENABLE	Enables the clock	0x0
3	R/W	QUAD_ENABLE	Enables the clock	0x0
2	R/W	I2C_ENABLE	Enables the clock	0x0
1	R/W	SPI_ENABLE	Enables the clock	0x0
0	R/W	UART_ENABLE	Enables the clock	0x0

Table 562: PCM_DIV_REG (0x50001C40)

Bit	Mode	Symbol	Description	Reset
13	R/W	PCM_SRC_SEL	Selects the clock source 1 = DIV1 clock 0 = DIVN clock	0x0
12	R/W	CLK_PCM_EN	Enable for the internally generated PCM clock The PCM_DIV must be set before or together with CLK_PCM_EN.	0x0
11:0	R/W	PCM_DIV	PCM clock divider	0x0

Table 563: PCM_FDIV_REG (0x50001C42)

Bit	Mode	Symbol	Description	Reset
15:0	R/W	PCM_FDIV	These bits define the fractional division part of the PCM clock. The left most '1' defines the denominator, the number of '1' bits define the numerator. E.g. 0x0110 means 2/9, with a distribution of 1.0001.0000 0xf000 means 13/16, with a distribution of 1111.1110.1110.1110	0x0

Table 564: PDM_DIV_REG (0x50001C44)

Bit	Mode	Symbol	Description	Reset
9	R/W	PDM_MASTER_MODE	Master mode selection 0: slave mode 1: master mode	0x0
8	R/W	CLK_PDM_EN	Enable for the internally generated PDM clock The PDM_DIV must be set before or together with CLK_PDM_EN.	0x0
7:0	R/W	PDM_DIV	PDM clock divider	0x0

Table 565: SRC_DIV_REG (0x50001C46)

Bit	Mode	Symbol	Description	Reset
8	R/W	CLK_SRC_EN	Enable for the internally generated SRC clock The SRC_DIV must be set before or together with CLK_SRC_EN.	0x0
7:0	R/W	SRC_DIV	SRC clock divider	0x0

Table 566: USBPAD_REG (0x50001C4A)

Bit	Mode	Symbol	Description	Reset
2	R/W	USBPHY_FORCE_SW2_ON	0: Pull up resistor SW2 is controlled by the USB controller. It is off when the USB is not enabled. 1: Force the pull up resistor on USBP to be 2.3Kohm	0x0
1	R/W	USBPHY_FORCE_SW1_OFF	0: Pull up resistor SW1 is controlled by the USB controller. It is off when the USB is not enabled. 1: Force the pull up resistor on USBP to be switched off.	0x0
0	R/W	USBPAD_EN	0: The power for the USB PHY and USB pads is switched on when the USB is enabled. 1: The power for the USB PHY and USB pads is forced on.	0x0

37.20 COEX REGISTER FILE

Table 567: Register map COEX

Address	Port	Description
0x50002F00	COEX_CTRL_REG	COEX Control Register
0x50002F02	COEX_STAT_REG	COEX Status Register
0x50002F04	COEX_INT_MASK_REG	COEX Interrupt Mask Register
0x50002F06	COEX_INT_STAT_REG	COEX Interrupt Status Register
0x50002F08	COEX_BLE_PTI_REG	COEX BLE PTI Control Register
0x50002F0C	COEX_DIAG_REG	COEX Diagnostic Monitor Register
0x50002F12	COEX_PRI1_REG	COEX Priority Register
0x50002F14	COEX_PRI2_REG	COEX Priority Register
0x50002F16	COEX_PRI3_REG	COEX Priority Register
0x50002F18	COEX_PRI4_REG	COEX Priority Register
0x50002F1A	COEX_PRI5_REG	COEX Priority Register
0x50002F1C	COEX_PRI6_REG	COEX Priority Register
0x50002F1E	COEX_PRI7_REG	COEX Priority Register
0x50002F20	COEX_PRI8_REG	COEX Priority Register
0x50002F22	COEX_PRI9_REG	COEX Priority Register
0x50002F24	COEX_PRI10_REG	COEX Priority Register
0x50002F26	COEX_PRI11_REG	COEX Priority Register
0x50002F28	COEX_PRI12_REG	COEX Priority Register
0x50002F2A	COEX_PRI13_REG	COEX Priority Register
0x50002F2C	COEX_PRI14_REG	COEX Priority Register
0x50002F2E	COEX_PRI15_REG	COEX Priority Register
0x50002F30	COEX_PRI16_REG	COEX Priority Register
0x50002F32	COEX_PRI17_REG	COEX Priority Register

Table 568: COEX_CTRL_REG (0x50002F00)

Bit	Mode	Symbol	Description	Reset
15	R/W	IGNORE_BLE	If set to "1" then all BLE requests are ignored by masking the internal "ble_active" signal. Refer also to IGNORE_BLE_STAT.	0x0
14	-	-	Reserved	0x0
13	R/W	IGNORE_EXT	If set to "1" then all EXT requests are ignored by masking the internal "ext_act" signal ("ext_act" is the logical OR of "ext_act0" and "ext_act1"). Refer also to IGNORE_EXT_STAT.	0x0
12:11	R/W	SEL_BLE_RADIO_B USY	Select the logic driving the BLE core input "ble.radio_busy": 0: (decision==BLE) AND rfcu.radio_busy. 1: Hold to "0". 2: (decision==EXT) OR rfcu.radio_busy. 3: (decision==EXT). Selection "0" is the default, while selection "2" is the recommended value if the BLE SW supports it.	0x0
10	R/W	SEL_BLE_WLAN_TX _RX	If set to "1" then the COEX block will drive the WLAN_TX and WLAN_RX inputs of the BLE core. Otherwise both BLE inputs will be forced to "0".	0x0
9	-	-	Reserved	0x0
8	-	-	Reserved	0x0
7	-	-	Reserved	0x0

Table 568: COEX_CTRL_REG (0x50002F00)

Bit	Mode	Symbol	Description	Reset
6:5	R/W	SEL_COEX_DIAG	The COEX block can provide internal diagnostic signals by overwriting the BLE diagnostic bus, which is forwarded to GPIO multiplexing. There is no need to program the BLE registers, but only this field and the GPIO PID fields. The encoding of this bitfield is: 0: Don't overwrite any BLE diagnostic signal. 1: Overwrite the BLE Diagnostic bits 2 down to 0: P2[2]: "closing" sub-state P2[1:0]: "decision" state 2: Overwrite the BLE Diagnostic bits 5 down to 3: P1[2]: "closing" sub-state P1[1:0]: "decision" state 3: Reserved..	0x0
4	R/W	SMART_ACT_IMPL	Controls the behavior of the SMART_ACT (and SMART_PRI as a consequence). If SMART_ACT_IMPL="0" then if any BLE MAC request is active then SMART_ACT will be asserted. SMART_ACT will actually be the "ble_active" signal. SMART_ACT will be asserted regardless the decision of the Arbiter to allow or disallow the access to the on-chip radio from the active MAC(s). if SMART_ACT_IMPL="1" then if the Arbiter's decision is to allow EXTERNAL MAC, then keep SMART_ACT to "0", otherwise follow the implementation of SMART_ACT_IMPL="0".	0x0
3	-	-	Reserved	0x0
2:1	-	-	Reserved	0x0
0	R/W	PRGING_ARBITER	If set to "1" then the current BLE transaction will complete normally and after that no further decision will be taken by the arbiter. The SW must keep this bit to "1" as long as it performs write operations on the COEX_PRI*_REG registers. As soon as the update on the priority registers will be completed, the SW should clear this bit. Note: This bit is updated with the COEX_CLK, so depending on the relationship between the PCLK and COEX_CLK periods a write operation to this bit may be effective in more than one PCLK clock cycles, e.g. when the COEX_CLK rate is slower than the PCLK.	0x0

Table 569: COEX_STAT_REG (0x50002F02)

Bit	Mode	Symbol	Description	Reset
15	R	IGNORE_BLE_STAT	If set to "1" then all BLE requests are ignored by masking immediately the request signal from the BLE. In more detail, the internal signal "ble_active" is the logical AND of this bitfield and the "ble.event_in_process".	0x0
14	-	-	Reserved	0x0
13	R	IGNORE_EXT_STAT	If set to "1" then all EXT requests are ignored by masking immediately the request signal from the external MAC. In more detail, the internal signal "ext_active" is the logical AND of this bitfield and the "ext_act".	0x0
12	R	COEX_RADIO_BUSY	Current state of RADIO_BUSY signal generated from RFCU, which is the logical OR among all Radio DCFs. Note that the arbiter will process this value with one COEX clock cycle delay.	0x0
11	R	EXT_ACT1	Current state of the pin.	0x0

Table 569: COEX_STAT_REG (0x50002F02)

Bit	Mode	Symbol	Description	Reset
10	R	EXT_ACT0	Current state of the pin.	0x0
9	R	SMART_PRI	Current state of the pin.	0x0
8	R	SMART_ACT	Current state of the pin.	0x0
7	R	COEX_DECISION_CLOSING	Provides the value of the "CLOSING" substate.	0x0
6:5	R	COEX_DECISION	Decision values: 0: Decision is NONE. 1: Decision is BLE. 2: Reserved 3: Decision is EXT. Note: If "0" (i.e. decision is NONE) then no MAC will have access to the on-chip radio. As a consequence, the SMART_PRI signal will stay low, since no on-chip (SMART) MAC will have priority. Note: The decision NONE will be held as long as there is no "*_active" internal signal from BLE or EXT. Also, if in programming state and the last transaction has been finished, then the decision will also be NONE. Note: While in programming mode, the COEX_PRIx_REGS are considered as invalid, which means that no new decision can be taken.	0x0
4:0	R	COEX_DECISION_PTR	Provides the number "x" of the COEX_PRIx_REG that win the last arbitration cycle. If "0" then it is a null pointer, pointing to no COEX_PRIx_REG.	0x0

Table 570: COEX_INT_MASK_REG (0x50002F04)

Bit	Mode	Symbol	Description	Reset
15	R/W	COEX_IRQ_ON_DECISION_SW	If "1" then a "1" on COEX_INT_STAT_REG[COEX_IRQ_ON_DECISION_SW] will cause COEX_IRQ_STAT to be set also to "1".	0x0
14	R/W	COEX_IRQ_ON_START_MID	If "1" then a "1" on COEX_INT_STAT_REG[COEX_IRQ_ON_START_MID] will cause COEX_IRQ_STAT to be set also to "1".	0x0
13	R/W	COEX_IRQ_ON_CLOSING_BRK	If "1" then a "1" on COEX_INT_STAT_REG[COEX_IRQ_ON_CLOSING_BRK] will cause COEX_IRQ_STAT to be set also to "1".	0x0
12	R/W	COEX_IRQ_ON_RADIO_BUSY_F	If "1" then a "1" on COEX_INT_STAT_REG[COEX_IRQ_ON_RADIO_BUSY_F] will cause COEX_IRQ_STAT to be set also to "1".	0x0
11	R/W	COEX_IRQ_ON_RADIO_BUSY_R	If "1" then a "1" on COEX_INT_STAT_REG[COEX_IRQ_ON_RADIO_BUSY_R] will cause COEX_IRQ_STAT to be set also to "1".	0x0
10	R/W	COEX_IRQ_ON_BLE_ACTIVE_F	If "1" then a "1" on COEX_INT_STAT_REG[COEX_IRQ_ON_BLE_ACTIVE_F] will cause COEX_IRQ_STAT to be set also to "1".	0x0
9	R/W	COEX_IRQ_ON_BLE_ACTIVE_R	If "1" then a "1" on COEX_INT_STAT_REG[COEX_IRQ_ON_BLE_ACTIVE_R] will cause COEX_IRQ_STAT to be set also to "1".	0x0
8	-	-	Reserved	0x0
7	-	-	Reserved	0x0

Table 570: COEX_INT_MASK_REG (0x50002F04)

Bit	Mode	Symbol	Description	Reset
6	R/W	COEX_IRQ_ON_EXT_ACT_F	If "1" then a "1" on COEX_INT_STAT_REG[COEX_IRQ_ON_EXT_ACT_F] will cause COEX_IRQ_STAT to be set also to "1".	0x0
5	R/W	COEX_IRQ_ON_EXT_ACT_R	If "1" then a "1" on COEX_INT_STAT_REG[COEX_IRQ_ON_EXT_ACT_R] will cause COEX_IRQ_STAT to be set also to "1".	0x0
4	R/W	COEX_IRQ_ON_SMART_PRI_F	If "1" then a "1" on COEX_INT_STAT_REG[COEX_IRQ_ON_SMART_PRI_F] will cause COEX_IRQ_STAT to be set also to "1".	0x0
3	R/W	COEX_IRQ_ON_SMART_PRI_R	If "1" then a "1" on COEX_INT_STAT_REG[COEX_IRQ_ON_SMART_PRI_R] will cause COEX_IRQ_STAT to be set also to "1".	0x0
2	R/W	COEX_IRQ_ON_SMART_ACT_F	If "1" then a "1" on COEX_INT_STAT_REG[COEX_IRQ_ON_SMART_ACT_F] will cause COEX_IRQ_STAT to be set also to "1".	0x0
1	R/W	COEX_IRQ_ON_SMART_ACT_R	If "1" then a "1" on COEX_INT_STAT_REG[COEX_IRQ_ON_SMART_ACT_R] will cause COEX_IRQ_STAT to be set also to "1".	0x0
0	R/W	COEX_IRQ_MASK	If set to "1" then sent an COEX_IRQ event to CPU as long as COEX_INT_STAT_REG[COEX_IRQ_STAT] is "1". If cleared then don't sent any IRQ event to CPU.	0x0

Table 571: COEX_INT_STAT_REG (0x50002F06)

Bit	Mode	Symbol	Description	Reset
15	RC	COEX_IRQ_ON_DECISION_SW	IRQ event when the decision switches to a new MAC. It ignores the intermediate transitions to DECISION==NONE. Note that after a Radio domain reset, the first transition of the decision to any MAC will also trigger this event.	0x0
14	RC	COEX_IRQ_ON_START_MID	IRQ event when the decision switches to a MAC, while the TX_EN or RX_EN of this MAC are high. This event signals a potential break of a transmission or reception.	0x0
13	RC	COEX_IRQ_ON_CLOSING_BRK	IRQ if while entering into "closing" sub-state, the TX_EN or RX_EN are active. This event signals a potential break of a transmission or reception.	0x0
12	RC	COEX_IRQ_ON_RADIO_BUSY_F	IRQ event on falling edge of RADIO_BUSY.	0x0
11	RC	COEX_IRQ_ON_RADIO_BUSY_R	IRQ event on rising edge of RADIO_BUSY.	0x0
10	RC	COEX_IRQ_ON_BLE_ACTIVE_F	IRQ event on falling edge of BLE_ACTIVE internal signal.	0x0
9	RC	COEX_IRQ_ON_BLE_ACTIVE_R	IRQ event on rising edge of BLE_ACTIVE internal signal.	0x0
8	-	-	Reserved	0x0
7	-	-	Reserved	0x0
6	RC	COEX_IRQ_ON_EXT_ACT_F	RQ event on falling edge of EXT_ACT.	0x0
5	RC	COEX_IRQ_ON_EXT_ACT_R	IRQ event on rising edge of EXT_ACT.	0x0
4	RC	COEX_IRQ_ON_SMART_PRI_F	IRQ event on falling edge of SMART_PRI.	0x0

Table 571: COEX_INT_STAT_REG (0x50002F06)

Bit	Mode	Symbol	Description	Reset
3	RC	COEX_IRQ_ON_SMART_PRI_R	IRQ event on rising edge of SMART_PRI.	0x0
2	RC	COEX_IRQ_ON_SMART_ACT_F	IRQ event on falling edge of SMART_ACT.	0x0
1	RC	COEX_IRQ_ON_SMART_ACT_R	IRQ event on rising edge of SMART_ACT.	0x0
0	RC	COEX_IRQ_STAT	For each COEX_IRQ_ON_* bitfield of COEX_INT_STAT_REG the corresponding mask is applied and afterwards all the intermediate results are combined with a logical OR in order to produce the COEX_IRQ_STAT bitfield. If furthermore the COEX_INT_MASK_REG[COEX_IRQ_MASK] is set to "1", then a COEX_IRQ signal will be forwarded to the CPU. Note: Each COEX_IRQ_ON_* bitfield of COEX_INT_STAT_REG will be set to "1" on the detection of the corresponding event and will be cleared to "0" on the read of COEX_INT_STAT_REG. The automated clear may delay a couple of PCLK cycles, depending on the relationship between PCLK and COEX_CLK.	0x0

Table 572: COEX_BLE_PTI_REG (0x50002F08)

Bit	Mode	Symbol	Description	Reset
15:3	-	-	Reserved	0x0
2:0	R/W	COEX_BLE_PTI	This value specifies the PTI value that characterizes the next BLE transaction that will be initiated on the following "ble_active" positive edge. The value should remain constant during the high period of the "ble_active" signal.	0x0

Table 573: COEX_DIAG_REG (0x50002F0C)

Bit	Mode	Symbol	Description	Reset
15:0	RC	COEX_DIAG_MON	provides the current value of the diagnostic bus forwarded to the GPIO multiplexing (named PPA). Refer to the Pxy_MODE_REG[PID] value BLE_DIAG.	0x0

Table 574: COEX_PRI1_REG (0x50002F12)

Bit	Mode	Symbol	Description	Reset
15:5	-	-	Reserved	0x0
4:3	R/W	COEX_PRI_MAC	Specifies the MAC that has been assigned with the specific priority level. The MAC encoding follows the COEX_DECISION bitfield encoding.	0x3
2:0	R/W	COEX_PRI_PTI	The priority level specified by this register will be applied to the packets coming from the MAC specified by the COEX_PRI_MAC bitfield and characterized with the PTI value specified by the COEX_PRI_PTI bitfield.	0x0

Table 575: COEX_PRI2_REG (0x50002F14)

Bit	Mode	Symbol	Description	Reset
15:5	-	-	Reserved	0x0

Table 575: COEX_PRI2_REG (0x50002F14)

Bit	Mode	Symbol	Description	Reset
4:3	R/W	COEX_PRI_MAC	Refer to COEX_PRI1_REG.	0x1
2:0	R/W	COEX_PRI_PT1	Refer to COEX_PRI1_REG.	0x0

Table 576: COEX_PRI3_REG (0x50002F16)

Bit	Mode	Symbol	Description	Reset
15:5	-	-	Reserved	0x0
4:3	R/W	COEX_PRI_MAC	Refer to COEX_PRI1_REG.	0x2
2:0	R/W	COEX_PRI_PT1	Refer to COEX_PRI1_REG.	0x0

Table 577: COEX_PRI4_REG (0x50002F18)

Bit	Mode	Symbol	Description	Reset
15:5	-	-	Reserved	0x0
4:3	R/W	COEX_PRI_MAC	Refer to COEX_PRI1_REG.	0x0
2:0	R/W	COEX_PRI_PT1	Refer to COEX_PRI1_REG.	0x0

Table 578: COEX_PRI5_REG (0x50002F1A)

Bit	Mode	Symbol	Description	Reset
15:5	-	-	Reserved	0x0
4:3	R/W	COEX_PRI_MAC	Refer to COEX_PRI1_REG.	0x0
2:0	R/W	COEX_PRI_PT1	Refer to COEX_PRI1_REG.	0x0

Table 579: COEX_PRI6_REG (0x50002F1C)

Bit	Mode	Symbol	Description	Reset
15:5	-	-	Reserved	0x0
4:3	R/W	COEX_PRI_MAC	Refer to COEX_PRI1_REG.	0x0
2:0	R/W	COEX_PRI_PT1	Refer to COEX_PRI1_REG.	0x0

Table 580: COEX_PRI7_REG (0x50002F1E)

Bit	Mode	Symbol	Description	Reset
15:5	-	-	Reserved	0x0
4:3	R/W	COEX_PRI_MAC	Refer to COEX_PRI1_REG.	0x0
2:0	R/W	COEX_PRI_PT1	Refer to COEX_PRI1_REG.	0x0

Table 581: COEX_PRI8_REG (0x50002F20)

Bit	Mode	Symbol	Description	Reset
15:5	-	-	Reserved	0x0
4:3	R/W	COEX_PRI_MAC	Refer to COEX_PRI1_REG.	0x0
2:0	R/W	COEX_PRI_PT1	Refer to COEX_PRI1_REG.	0x0

Table 582: COEX_PRI9_REG (0x50002F22)

Bit	Mode	Symbol	Description	Reset
15:5	-	-	Reserved	0x0
4:3	R/W	COEX_PRI_MAC	Refer to COEX_PRI1_REG.	0x0
2:0	R/W	COEX_PRI_PTI	Refer to COEX_PRI1_REG.	0x0

Table 583: COEX_PRI10_REG (0x50002F24)

Bit	Mode	Symbol	Description	Reset
15:5	-	-	Reserved	0x0
4:3	R/W	COEX_PRI_MAC	Refer to COEX_PRI1_REG.	0x0
2:0	R/W	COEX_PRI_PTI	Refer to COEX_PRI1_REG.	0x0

Table 584: COEX_PRI11_REG (0x50002F26)

Bit	Mode	Symbol	Description	Reset
15:5	-	-	Reserved	0x0
4:3	R/W	COEX_PRI_MAC	Refer to COEX_PRI1_REG.	0x0
2:0	R/W	COEX_PRI_PTI	Refer to COEX_PRI1_REG.	0x0

Table 585: COEX_PRI12_REG (0x50002F28)

Bit	Mode	Symbol	Description	Reset
15:5	-	-	Reserved	0x0
4:3	R/W	COEX_PRI_MAC	Refer to COEX_PRI1_REG.	0x0
2:0	R/W	COEX_PRI_PTI	Refer to COEX_PRI1_REG.	0x0

Table 586: COEX_PRI13_REG (0x50002F2A)

Bit	Mode	Symbol	Description	Reset
15:5	-	-	Reserved	0x0
4:3	R/W	COEX_PRI_MAC	Refer to COEX_PRI1_REG.	0x0
2:0	R/W	COEX_PRI_PTI	Refer to COEX_PRI1_REG.	0x0

Table 587: COEX_PRI14_REG (0x50002F2C)

Bit	Mode	Symbol	Description	Reset
15:5	-	-	Reserved	0x0
4:3	R/W	COEX_PRI_MAC	Refer to COEX_PRI1_REG.	0x0
2:0	R/W	COEX_PRI_PTI	Refer to COEX_PRI1_REG.	0x0

Table 588: COEX_PRI15_REG (0x50002F2E)

Bit	Mode	Symbol	Description	Reset
15:5	-	-	Reserved	0x0
4:3	R/W	COEX_PRI_MAC	Refer to COEX_PRI1_REG.	0x0
2:0	R/W	COEX_PRI_PTI	Refer to COEX_PRI1_REG.	0x0

Table 589: COEX_PRI16_REG (0x50002F30)

Bit	Mode	Symbol	Description	Reset
15:5	-	-	Reserved	0x0
4:3	R/W	COEX_PRI_MAC	Refer to COEX_PRI1_REG.	0x0
2:0	R/W	COEX_PRI_PTI	Refer to COEX_PRI1_REG.	0x0

Table 590: COEX_PRI17_REG (0x50002F32)

Bit	Mode	Symbol	Description	Reset
15:5	-	-	Reserved	0x0
4:3	R/W	COEX_PRI_MAC	Refer to COEX_PRI1_REG.	0x0
2:0	R/W	COEX_PRI_PTI	Refer to COEX_PRI1_REG.	0x0

37.21 GPIO REGISTER FILE

Table 591: Register map GPIO

Address	Port	Description
0x50003000	P0_DATA_REG	P0 Data input / output Register
0x50003002	P1_DATA_REG	P1 Data input / output Register
0x50003004	P2_DATA_REG	P2 Data input / output Register
0x50003006	P3_DATA_REG	P3 Data input / output Register
0x50003008	P4_DATA_REG	P4 Data input / output Register
0x5000300A	P0_SET_DATA_REG	P0 Set port pins Register
0x5000300C	P1_SET_DATA_REG	P1 Set port pins Register
0x5000300E	P2_SET_DATA_REG	P2 Set port pins Register
0x50003010	P3_SET_DATA_REG	P3 Set port pins Register
0x50003012	P4_SET_DATA_REG	P4 Set port pins Register
0x50003014	P0_RESET_DATA_REG	P0 Reset port pins Register
0x50003016	P1_RESET_DATA_REG	P1 Reset port pins Register
0x50003018	P2_RESET_DATA_REG	P2 Reset port pins Register
0x5000301A	P3_RESET_DATA_REG	P3 Reset port pins Register
0x5000301C	P4_RESET_DATA_REG	P4 Reset port pins Register
0x5000301E	P00_MODE_REG	P00 Mode Register
0x50003020	P01_MODE_REG	P01 Mode Register
0x50003022	P02_MODE_REG	P02 Mode Register
0x50003024	P03_MODE_REG	P03 Mode Register
0x50003026	P04_MODE_REG	P04 Mode Register
0x50003028	P05_MODE_REG	P05 Mode Register
0x5000302A	P06_MODE_REG	P06 Mode Register
0x5000302C	P07_MODE_REG	P07 Mode Register
0x5000302E	P10_MODE_REG	P10 Mode Register
0x50003030	P11_MODE_REG	P11 Mode Register
0x50003032	P12_MODE_REG	P12 Mode Register
0x50003034	P13_MODE_REG	P13 Mode Register
0x50003036	P14_MODE_REG	P14 Mode Register
0x50003038	P15_MODE_REG	P15 Mode Register
0x5000303A	P16_MODE_REG	P24 Mode Register
0x5000303C	P17_MODE_REG	P25 Mode Register
0x5000303E	P20_MODE_REG	P20 Mode Register
0x50003040	P21_MODE_REG	P21 Mode Register
0x50003042	P22_MODE_REG	P22 Mode Register
0x50003044	P23_MODE_REG	P23 Mode Register
0x50003046	P24_MODE_REG	P24 Mode Register
0x5000304E	P30_MODE_REG	P30 Mode Register
0x50003050	P31_MODE_REG	P31 Mode Register
0x50003052	P32_MODE_REG	P32 Mode Register
0x50003054	P33_MODE_REG	P33 Mode Register
0x50003056	P34_MODE_REG	P34 Mode Register
0x50003058	P35_MODE_REG	P35 Mode Register
0x5000305A	P36_MODE_REG	P36 Mode Register

Table 591: Register map GPIO

Address	Port	Description
0x5000305C	P37_MODE_REG	P37 Mode Register
0x5000305E	P40_MODE_REG	P40 Mode Register
0x50003060	P41_MODE_REG	P41 Mode Register
0x50003062	P42_MODE_REG	P42 Mode Register
0x50003064	P43_MODE_REG	P43 Mode Register
0x50003066	P44_MODE_REG	P44 Mode Register
0x50003068	P45_MODE_REG	P45 Mode Register
0x5000306A	P46_MODE_REG	P46 Mode Register
0x5000306C	P47_MODE_REG	P47 Mode Register
0x500030C0	P0_PADPWR_CTRL_REG	P0 Output Power Control Register
0x500030C2	P1_PADPWR_CTRL_REG	P1 Output Power Control Register
0x500030C4	P2_PADPWR_CTRL_REG	P2 Output Power Control Register
0x500030C6	P3_PADPWR_CTRL_REG	P3 Output Power Control Register
0x500030C8	P4_PADPWR_CTRL_REG	P4 Output Power Control Register
0x500030D0	GPIO_CLK_SEL	Select which clock to map on port in PPA

Table 592: P0_DATA_REG (0x50003000)

Bit	Mode	Symbol	Description	Reset
15:8	-	-	Reserved	0x0
7:0	R/W	P0_DATA	Set P0 output register when written; Returns the value of P0 port when read	0x0

Table 593: P1_DATA_REG (0x50003002)

Bit	Mode	Symbol	Description	Reset
15:8	-	-	Reserved	0x0
7:0	R/W	P1_DATA	Set P1 output register when written; Returns the value of P1 port when read	0x0

Table 594: P2_DATA_REG (0x50003004)

Bit	Mode	Symbol	Description	Reset
15:5	-	-	Reserved	0x0
4:0	R/W	P2_DATA	Set P2 output register when written; Returns the value of P2 port when read	0x0

Table 595: P3_DATA_REG (0x50003006)

Bit	Mode	Symbol	Description	Reset
15:8	-	-	Reserved	0x0
7:0	R/W	P3_DATA	Set P3 output register when written; Returns the value of P3 port when read	0x0

Table 596: P4_DATA_REG (0x50003008)

Bit	Mode	Symbol	Description	Reset
15:8	-	-	Reserved	0x0

Table 596: P4_DATA_REG (0x50003008)

Bit	Mode	Symbol	Description	Reset
7:0	R/W	P4_DATA	Set P4 output register when written; Returns the value of P4 port when read	0x0

Table 597: P0_SET_DATA_REG (0x5000300A)

Bit	Mode	Symbol	Description	Reset
15:8	-	-	Reserved	0x0
7:0	R/W	P0_SET	Writing a 1 to P0[y] sets P0[y] to 1. Writing 0 is discarded; Reading returns 0	0x0

Table 598: P1_SET_DATA_REG (0x5000300C)

Bit	Mode	Symbol	Description	Reset
15:8	-	-	Reserved	0x0
7:0	R/W	P1_SET	Writing a 1 to P1[y] sets P1[y] to 1. Writing 0 is discarded; Reading returns 0	0x0

Table 599: P2_SET_DATA_REG (0x5000300E)

Bit	Mode	Symbol	Description	Reset
15:5	-	-	Reserved	0x0
4:0	R/W	P2_SET	Writing a 1 to P2[y] sets P2[y] to 1. Writing 0 is discarded; Reading returns 0	0x0

Table 600: P3_SET_DATA_REG (0x50003010)

Bit	Mode	Symbol	Description	Reset
15:8	-	-	Reserved	0x0
7:0	R0/W	P3_SET	Writing a 1 to P3[y] sets P3[y] to 1. Writing 0 is discarded; Reading returns 0	0x0

Table 601: P4_SET_DATA_REG (0x50003012)

Bit	Mode	Symbol	Description	Reset
15:8	-	-	Reserved	0x0
7:0	R0/W	P4_SET	Writing a 1 to P4[y] sets P4[y] to 1. Writing 0 is discarded; Reading returns 0	0x0

Table 602: P0_RESET_DATA_REG (0x50003014)

Bit	Mode	Symbol	Description	Reset
15:8	-	-	Reserved	0x0
7:0	R/W	P0_RESET	Writing a 1 to P0[y] sets P0[y] to 0. Writing 0 is discarded; Reading returns 0	0x0

Table 603: P1_RESET_DATA_REG (0x50003016)

Bit	Mode	Symbol	Description	Reset
15:8	-	-	Reserved	0x0

Table 603: P1_RESET_DATA_REG (0x50003016)

Bit	Mode	Symbol	Description	Reset
7:0	R/W	P1_RESET	Writing a 1 to P1[y] sets P1[y] to 0. Writing 0 is discarded; Reading returns 0	0x0

Table 604: P2_RESET_DATA_REG (0x50003018)

Bit	Mode	Symbol	Description	Reset
15:5	-	-	Reserved	0x0
4:0	R/W	P2_RESET	Writing a 1 to P2[y] sets P2[y] to 0. Writing 0 is discarded; Reading returns 0	0x0

Table 605: P3_RESET_DATA_REG (0x5000301A)

Bit	Mode	Symbol	Description	Reset
15:8	-	-	Reserved	0x0
7:0	R0/W	P3_RESET	Writing a 1 to P3[y] sets P3[y] to 0. Writing 0 is discarded; Reading returns 0	0x0

Table 606: P4_RESET_DATA_REG (0x5000301C)

Bit	Mode	Symbol	Description	Reset
15:8	-	-	Reserved	0x0
7:0	R0/W	P4_RESET	Writing a 1 to P4[y] sets P4[y] to 0. Writing 0 is discarded; Reading returns 0	0x0

Table 607: P00_MODE_REG (0x5000301E)

Bit	Mode	Symbol	Description	Reset
15:11	-	-	Reserved	0x0
10	R/W	PPOD	0: Push pull 1: Open drain	0x0
9:8	R/W	PUPD	00 = Input, no resistors selected 01 = Input, pull-up selected 10 = Input, pull-down selected 11 = Output, no resistors selected In ADC mode, these bits are don't care	0x2
7:6	-	-	Reserved	0x0

Table 607: P00_MODE_REG (0x5000301E)

Bit	Mode	Symbol	Description	Reset
5:0	R/W	PID	Function of port: 0: GPIO, PUPD (see above) 1: UART_RX 2: UART_TX 3: UART_IRDA_RX 4: UART_IRDA_TX 5: UART2_RX 6: UART2_TX 7: UART2_IRDA_RX 8: UART2_IRDA_TX 9: UART2_CTSN 10: UART2_RTSN 11: SPI_DI 12: SPI_DO 13: SPI_CLK 14: SPI_EN 15: SPI2_DI 16: SPI2_DO 17: SPI2_CLK 18: SPI2_EN 19: I2C_SCL 20: I2C_SDA 21: I2C2_SCL 22: I2C2_SDA 23: PWM0 24: PWM1 25: PWM2 26: PWM3 27: PWM4 28: BLE_DIAG (ble_diag_0: P2_0, ble_diag_1: P2_1, ble_diag_2: P2_2, ble_diag_3: P1_0, ble_diag_4: P1_1, ble_diag_5: P1_2, ble_diag_6: P1_3, ble_diag_7: P2_3) 29: Reserved 30: PCM_DI 31: PCM_DO 32: PCM_FSC 33: PCM_CLK 34: PDM_DI 35: PDM_DO 36: PDM_CLK 37: USB_SOF 38: ADC (only for P0[7:6], P1[5:2,0] and P2[4]) 38: USB (only for P2[2] and P1[1]) 38: XTAL32 (only for P2[1:0]) 39: QD_CHA_X 40: QD_CHB_X 41: QD_CHA_Y 42: QD_CHB_Y 43: QD_CHA_Z 44: QD_CHB_Z 45: IR_OUT 46: BREATH 47: KB_ROW 48: COEX_EXT_ACT0 49: COEX_EXT_ACT1 50: COEX_SMART_ACT (continued on next page)	0x0

Table 607: P00_MODE_REG (0x5000301E)

Bit	Mode	Symbol	Description	Reset
5:0	R/W	PID (continued)	51: COEX_SMART_PRI 52: CLOCK 53: ONESHOT 54: PWM5 55: PORT0_DCF 56: PORT1_DCF 57: PORT2_DCF 58: PORT3_DCF 59: PORT4_DCF 60: RF_ANT_TRIM[0] 61: RF_ANT_TRIM[1] 62: RF_ANT_TRIM[2] (Note 20)	0x0

Note 20: Note: when a certain input function (like SPI_DI) is selected on more than 1 port pin, the port with the lowest index has the highest priority and P0 has higher priority than P1.

Table 608: P01_MODE_REG (0x50003020)

Bit	Mode	Symbol	Description	Reset
15:11	-	-	Reserved	0x0
10	R/W	PPOD	0: Push pull 1: Open drain	0x0
9:8	R/W	PUPD	00 = Input, no resistors selected 01 = Input, pull-up selected 10 = Input, pull-down selected 11 = Output, no resistors selected In ADC mode, these bits are don't care	0x2
7:6	-	-	Reserved	0x0
5:0	R/W	PID	See P00_MODE_REG[PID]	0x0

Table 609: P02_MODE_REG (0x50003022)

Bit	Mode	Symbol	Description	Reset
15:11	-	-	Reserved	0x0
10	R/W	PPOD	0: Push pull 1: Open drain	0x0
9:8	R/W	PUPD	00 = Input, no resistors selected 01 = Input, pull-up selected 10 = Input, pull-down selected 11 = Output, no resistors selected In ADC mode, these bits are don't care	0x2
7:6	-	-	Reserved	0x0
5:0	R/W	PID	See P00_MODE_REG[PID]	0x0

Table 610: P03_MODE_REG (0x50003024)

Bit	Mode	Symbol	Description	Reset
15:11	-	-	Reserved	0x0
10	R/W	PPOD	0: Push pull 1: Open drain	0x0

Table 610: P03_MODE_REG (0x50003024)

Bit	Mode	Symbol	Description	Reset
9:8	R/W	PUPD	00 = Input, no resistors selected 01 = Input, pull-up selected 10 = Input, pull-down selected 11 = Output, no resistors selected In ADC mode, these bits are don't care	0x2
7:6	-	-	Reserved	0x0
5:0	R/W	PID	See P00_MODE_REG[PID]	0x0

Table 611: P04_MODE_REG (0x50003026)

Bit	Mode	Symbol	Description	Reset
15:11	-	-	Reserved	0x0
10	R/W	PPOD	0: Push pull 1: Open drain	0x0
9:8	R/W	PUPD	00 = Input, no resistors selected 01 = Input, pull-up selected 10 = Input, pull-down selected 11 = Output, no resistors selected In ADC mode, these bits are don't care	0x2
7:6	-	-	Reserved	0x0
5:0	R/W	PID	See P00_MODE_REG[PID]	0x0

Table 612: P05_MODE_REG (0x50003028)

Bit	Mode	Symbol	Description	Reset
15:11	-	-	Reserved	0x0
10	R/W	PPOD	0: Push pull 1: Open drain	0x0
9:8	R/W	PUPD	00 = Input, no resistors selected 01 = Input, pull-up selected 10 = Input, pull-down selected 11 = Output, no resistors selected In ADC mode, these bits are don't care	0x1
7:6	-	-	Reserved	0x0
5:0	R/W	PID	See P00_MODE_REG[PID]	0x0

Table 613: P06_MODE_REG (0x5000302A)

Bit	Mode	Symbol	Description	Reset
15:11	-	-	Reserved	0x0
10	R/W	PPOD	0: Push pull 1: Open drain	0x0
9:8	R/W	PUPD	00 = Input, no resistors selected 01 = Input, pull-up selected 10 = Input, pull-down selected 11 = Output, no resistors selected In ADC mode, these bits are don't care	0x2
7:6	-	-	Reserved	0x0
5:0	R/W	PID	See P00_MODE_REG[PID]	0x0

Table 614: P07_MODE_REG (0x5000302C)

Bit	Mode	Symbol	Description	Reset
15:11	-	-	Reserved	0x0
10	R/W	PPOD	0: Push pull 1: Open drain	0x0
9:8	R/W	PUPD	00 = Input, no resistors selected 01 = Input, pull-up selected 10 = Input, pull-down selected 11 = Output, no resistors selected In ADC mode, these bits are don't care	0x2
7:6	-	-	Reserved	0x0
5:0	R/W	PID	See P00_MODE_REG[PID]	0x0

Table 615: P10_MODE_REG (0x5000302E)

Bit	Mode	Symbol	Description	Reset
15:11	-	-	Reserved	0x0
10	R/W	PPOD	0: Push pull 1: Open drain	0x0
9:8	R/W	PUPD	00 = Input, no resistors selected 01 = Input, pull-up selected 10 = Input, pull-down selected 11 = Output, no resistors selected In ADC mode, these bits are don't care	0x2
7:6	-	-	Reserved	0x0
5:0	R/W	PID	See P00_MODE_REG[PID]	0x0

Table 616: P11_MODE_REG (0x50003030)

Bit	Mode	Symbol	Description	Reset
15:11	-	-	Reserved	0x0
10	R/W	PPOD	0: Push pull 1: Open drain	0x0
9:8	R/W	PUPD	00 = Input, no resistors selected 01 = Input, pull-up selected 10 = Input, pull-down selected 11 = Output, no resistors selected In ADC mode, these bits are don't care	0x2
7:6	-	-	Reserved	0x0
5:0	R/W	PID	See P00_MODE_REG[PID]	0x0

Table 617: P12_MODE_REG (0x50003032)

Bit	Mode	Symbol	Description	Reset
15:11	-	-	Reserved	0x0
10	R/W	PPOD	0: Push pull 1: Open drain	0x0
9:8	R/W	PUPD	00 = Input, no resistors selected 01 = Input, pull-up selected 10 = Input, pull-down selected 11 = Output, no resistors selected In ADC mode, these bits are don't care	0x2

Table 617: P12_MODE_REG (0x50003032)

Bit	Mode	Symbol	Description	Reset
7:6	-	-	Reserved	0x0
5:0	R/W	PID	See P00_MODE_REG[PID]	0x0

Table 618: P13_MODE_REG (0x50003034)

Bit	Mode	Symbol	Description	Reset
15:11	-	-	Reserved	0x0
10	R/W	PPOD	0: Push pull 1: Open drain	0x0
9:8	R/W	PUPD	00 = Input, no resistors selected 01 = Input, pull-up selected 10 = Input, pull-down selected 11 = Output, no resistors selected In ADC mode, these bits are don't care	0x2
7:6	-	-	Reserved	0x0
5:0	R/W	PID	See P00_MODE_REG[PID]	0x0

Table 619: P14_MODE_REG (0x50003036)

Bit	Mode	Symbol	Description	Reset
15:11	-	-	Reserved	0x0
10	R/W	PPOD	0: Push pull 1: Open drain	0x0
9:8	R/W	PUPD	00 = Input, no resistors selected 01 = Input, pull-up selected 10 = Input, pull-down selected 11 = Output, no resistors selected In ADC mode, these bits are don't care	0x2
7:6	-	-	Reserved	0x0
5:0	R/W	PID	See P00_MODE_REG[PID]	0x0

Table 620: P15_MODE_REG (0x50003038)

Bit	Mode	Symbol	Description	Reset
15:11	-	-	Reserved	0x0
10	R/W	PPOD	0: Push pull 1: Open drain	0x0
9:8	R/W	PUPD	00 = Input, no resistors selected 01 = Input, pull-up selected 10 = Input, pull-down selected 11 = Output, no resistors selected In ADC mode, these bits are don't care	0x1
7:6	-	-	Reserved	0x0
5:0	R/W	PID	See P00_MODE_REG[PID]	0x0

Table 621: P16_MODE_REG (0x5000303A)

Bit	Mode	Symbol	Description	Reset
15:11	-	-	Reserved	0x0

Table 621: P16_MODE_REG (0x5000303A)

Bit	Mode	Symbol	Description	Reset
10	R/W	PPOD	0: Push pull 1: Open drain	0x0
9:8	R/W	PUPD	00 = Input, no resistors selected 01 = Input, pull-up selected 10 = Input, pull-down selected 11 = Output, no resistors selected In ADC mode, these bits are don't care	0x1
7:6	-	-	Reserved	0x0
5:0	R/W	PID	See P00_MODE_REG[PID]	0x0

Table 622: P17_MODE_REG (0x5000303C)

Bit	Mode	Symbol	Description	Reset
15:11	-	-	Reserved	0x0
10	R/W	PPOD	0: Push pull 1: Open drain	0x0
9:8	R/W	PUPD	00 = Input, no resistors selected 01 = Input, pull-up selected 10 = Input, pull-down selected 11 = Output, no resistors selected In ADC mode, these bits are don't care	0x2
7:6	-	-	Reserved	0x0
5:0	R/W	PID	See P00_MODE_REG[PID]	0x0

Table 623: P20_MODE_REG (0x5000303E)

Bit	Mode	Symbol	Description	Reset
15:11	-	-	Reserved	0x0
10	R/W	PPOD	0: Push pull 1: Open drain	0x0
9:8	R/W	PUPD	00 = Input, no resistors selected 01 = Input, pull-up selected 10 = Input, pull-down selected 11 = Output, no resistors selected In ADC mode, these bits are don't care	0x2
7:6	-	-	Reserved	0x0
5:0	R/W	PID	See P00_MODE_REG[PID]	0x0

Table 624: P21_MODE_REG (0x50003040)

Bit	Mode	Symbol	Description	Reset
15:11	-	-	Reserved	0x0
10	R/W	PPOD	0: Push pull 1: Open drain	0x0
9:8	R/W	PUPD	00 = Input, no resistors selected 01 = Input, pull-up selected 10 = Input, pull-down selected 11 = Output, no resistors selected In ADC mode, these bits are don't care	0x2
7:6	-	-	Reserved	0x0
5:0	R/W	PID	See P00_MODE_REG[PID]	0x0

Table 625: P22_MODE_REG (0x50003042)

Bit	Mode	Symbol	Description	Reset
15:11	-	-	Reserved	0x0
10	R/W	PPOD	0: Push pull 1: Open drain	0x0
9:8	R/W	PUPD	00 = Input, no resistors selected 01 = Input, pull-up selected 10 = Input, pull-down selected 11 = Output, no resistors selected In ADC mode, these bits are don't care	0x2
7:6	-	-	Reserved	0x0
5:0	R/W	PID	See P00_MODE_REG[PID]	0x0

Table 626: P23_MODE_REG (0x50003044)

Bit	Mode	Symbol	Description	Reset
15:11	-	-	Reserved	0x0
10	R/W	PPOD	0: Push pull 1: Open drain	0x0
9:8	R/W	PUPD	00 = Input, no resistors selected 01 = Input, pull-up selected 10 = Input, pull-down selected 11 = Output, no resistors selected In ADC mode, these bits are don't care	0x2
7:6	-	-	Reserved	0x0
5:0	R/W	PID	See P00_MODE_REG[PID]	0x0

Table 627: P24_MODE_REG (0x50003046)

Bit	Mode	Symbol	Description	Reset
15:11	-	-	Reserved	0x0
10	R/W	PPOD	0: Push pull 1: Open drain	0x0
9:8	R/W	PUPD	00 = Input, no resistors selected 01 = Input, pull-up selected 10 = Input, pull-down selected 11 = Output, no resistors selected In ADC mode, these bits are don't care	0x2
7:6	-	-	Reserved	0x0
5:0	R/W	PID	See P00_MODE_REG[PID]	0x0

Table 628: P30_MODE_REG (0x5000304E)

Bit	Mode	Symbol	Description	Reset
15:11	-	-	Reserved	0x0
10	R/W	PPOD	0: Push pull 1: Open drain	0x0
9:8	R/W	PUPD	00 = Input, no resistors selected 01 = Input, pull-up selected 10 = Input, pull-down selected 11 = Output, no resistors selected In ADC mode, these bits are don't care	0x2

Table 628: P30_MODE_REG (0x5000304E)

Bit	Mode	Symbol	Description	Reset
7:6	-	-	Reserved	0x0
5:0	R/W	PID	See P00_MODE_REG[PID]	0x0

Table 629: P31_MODE_REG (0x50003050)

Bit	Mode	Symbol	Description	Reset
15:11	-	-	Reserved	0x0
10	R/W	PPOD	0: Push pull 1: Open drain	0x0
9:8	R/W	PUPD	00 = Input, no resistors selected 01 = Input, pull-up selected 10 = Input, pull-down selected 11 = Output, no resistors selected In ADC mode, these bits are don't care	0x2
7:6	-	-	Reserved	0x0
5:0	R/W	PID	See P00_MODE_REG[PID]	0x0

Table 630: P32_MODE_REG (0x50003052)

Bit	Mode	Symbol	Description	Reset
15:11	-	-	Reserved	0x0
10	R/W	PPOD	0: Push pull 1: Open drain	0x0
9:8	R/W	PUPD	00 = Input, no resistors selected 01 = Input, pull-up selected 10 = Input, pull-down selected 11 = Output, no resistors selected In ADC mode, these bits are don't care	0x2
7:6	-	-	Reserved	0x0
5:0	R/W	PID	See P00_MODE_REG[PID]	0x0

Table 631: P33_MODE_REG (0x50003054)

Bit	Mode	Symbol	Description	Reset
15:11	-	-	Reserved	0x0
10	R/W	PPOD	0: Push pull 1: Open drain	0x0
9:8	R/W	PUPD	00 = Input, no resistors selected 01 = Input, pull-up selected 10 = Input, pull-down selected 11 = Output, no resistors selected In ADC mode, these bits are don't care	0x2
7:6	-	-	Reserved	0x0
5:0	R/W	PID	See P00_MODE_REG[PID]	0x0

Table 632: P34_MODE_REG (0x50003056)

Bit	Mode	Symbol	Description	Reset
15:11	-	-	Reserved	0x0

Table 632: P34_MODE_REG (0x50003056)

Bit	Mode	Symbol	Description	Reset
10	R/W	PPOD	0: Push pull 1: Open drain	0x0
9:8	R/W	PUPD	00 = Input, no resistors selected 01 = Input, pull-up selected 10 = Input, pull-down selected 11 = Output, no resistors selected In ADC mode, these bits are don't care	0x2
7:6	-	-	Reserved	0x0
5:0	R/W	PID	See P00_MODE_REG[PID]	0x0

Table 633: P35_MODE_REG (0x50003058)

Bit	Mode	Symbol	Description	Reset
15:11	-	-	Reserved	0x0
10	R/W	PPOD	0: Push pull 1: Open drain	0x0
9:8	R/W	PUPD	00 = Input, no resistors selected 01 = Input, pull-up selected 10 = Input, pull-down selected 11 = Output, no resistors selected In ADC mode, these bits are don't care	0x2
7:6	-	-	Reserved	0x0
5:0	R/W	PID	See P00_MODE_REG[PID]	0x0

Table 634: P36_MODE_REG (0x5000305A)

Bit	Mode	Symbol	Description	Reset
15:11	-	-	Reserved	0x0
10	R/W	PPOD	0: Push pull 1: Open drain	0x0
9:8	R/W	PUPD	00 = Input, no resistors selected 01 = Input, pull-up selected 10 = Input, pull-down selected 11 = Output, no resistors selected In ADC mode, these bits are don't care	0x2
7:6	-	-	Reserved	0x0
5:0	R/W	PID	See P00_MODE_REG[PID]	0x0

Table 635: P37_MODE_REG (0x5000305C)

Bit	Mode	Symbol	Description	Reset
15:11	-	-	Reserved	0x0
10	R/W	PPOD	0: Push pull 1: Open drain	0x0
9:8	R/W	PUPD	00 = Input, no resistors selected 01 = Input, pull-up selected 10 = Input, pull-down selected 11 = Output, no resistors selected In ADC mode, these bits are don't care	0x2
7:6	-	-	Reserved	0x0
5:0	R/W	PID	See P00_MODE_REG[PID]	0x0

Table 636: P40_MODE_REG (0x5000305E)

Bit	Mode	Symbol	Description	Reset
15:11	-	-	Reserved	0x0
10	R/W	PPOD	0: Push pull 1: Open drain	0x0
9:8	R/W	PUPD	00 = Input, no resistors selected 01 = Input, pull-up selected 10 = Input, pull-down selected 11 = Output, no resistors selected In ADC mode, these bits are don't care	0x2
7:6	-	-	Reserved	0x0
5:0	R/W	PID	See P00_MODE_REG[PID]	0x0

Table 637: P41_MODE_REG (0x50003060)

Bit	Mode	Symbol	Description	Reset
15:11	-	-	Reserved	0x0
10	R/W	PPOD	0: Push pull 1: Open drain	0x0
9:8	R/W	PUPD	00 = Input, no resistors selected 01 = Input, pull-up selected 10 = Input, pull-down selected 11 = Output, no resistors selected In ADC mode, these bits are don't care	0x2
7:6	-	-	Reserved	0x0
5:0	R/W	PID	See P00_MODE_REG[PID]	0x0

Table 638: P42_MODE_REG (0x50003062)

Bit	Mode	Symbol	Description	Reset
15:11	-	-	Reserved	0x0
10	R/W	PPOD	0: Push pull 1: Open drain	0x0
9:8	R/W	PUPD	00 = Input, no resistors selected 01 = Input, pull-up selected 10 = Input, pull-down selected 11 = Output, no resistors selected In ADC mode, these bits are don't care	0x2
7:6	-	-	Reserved	0x0
5:0	R/W	PID	See P00_MODE_REG[PID]	0x0

Table 639: P43_MODE_REG (0x50003064)

Bit	Mode	Symbol	Description	Reset
15:11	-	-	Reserved	0x0
10	R/W	PPOD	0: Push pull 1: Open drain	0x0
9:8	R/W	PUPD	00 = Input, no resistors selected 01 = Input, pull-up selected 10 = Input, pull-down selected 11 = Output, no resistors selected In ADC mode, these bits are don't care	0x2

Table 639: P43_MODE_REG (0x50003064)

Bit	Mode	Symbol	Description	Reset
7:6	-	-	Reserved	0x0
5:0	R/W	PID	See P00_MODE_REG[PID]	0x0

Table 640: P44_MODE_REG (0x50003066)

Bit	Mode	Symbol	Description	Reset
15:11	-	-	Reserved	0x0
10	R/W	PPOD	0: Push pull 1: Open drain	0x0
9:8	R/W	PUPD	00 = Input, no resistors selected 01 = Input, pull-up selected 10 = Input, pull-down selected 11 = Output, no resistors selected In ADC mode, these bits are don't care	0x2
7:6	-	-	Reserved	0x0
5:0	R/W	PID	See P00_MODE_REG[PID]	0x0

Table 641: P45_MODE_REG (0x50003068)

Bit	Mode	Symbol	Description	Reset
15:11	-	-	Reserved	0x0
10	R/W	PPOD	0: Push pull 1: Open drain	0x0
9:8	R/W	PUPD	00 = Input, no resistors selected 01 = Input, pull-up selected 10 = Input, pull-down selected 11 = Output, no resistors selected In ADC mode, these bits are don't care	0x2
7:6	-	-	Reserved	0x0
5:0	R/W	PID	See P00_MODE_REG[PID]	0x0

Table 642: P46_MODE_REG (0x5000306A)

Bit	Mode	Symbol	Description	Reset
15:11	-	-	Reserved	0x0
10	R/W	PPOD	0: Push pull 1: Open drain	0x0
9:8	R/W	PUPD	00 = Input, no resistors selected 01 = Input, pull-up selected 10 = Input, pull-down selected 11 = Output, no resistors selected In ADC mode, these bits are don't care	0x2
7:6	-	-	Reserved	0x0
5:0	R/W	PID	See P00_MODE_REG[PID]	0x0

Table 643: P47_MODE_REG (0x5000306C)

Bit	Mode	Symbol	Description	Reset
15:11	-	-	Reserved	0x0

Table 643: P47_MODE_REG (0x5000306C)

Bit	Mode	Symbol	Description	Reset
10	R/W	PPOD	0: Push pull 1: Open drain	0x0
9:8	R/W	PUPD	00 = Input, no resistors selected 01 = Input, pull-up selected 10 = Input, pull-down selected 11 = Output, no resistors selected In ADC mode, these bits are don't care	0x2
7:6	-	-	Reserved	0x0
5:0	R/W	PID	See P00_MODE_REG[PID]	0x0

Table 644: P0_PADPWR_CTRL_REG (0x500030C0)

Bit	Mode	Symbol	Description	Reset
15:8	-	-	Reserved	0x0
7:6	R/W	P0_OUT_CTRL	1 = P0_x port output is powered by VDD1V8P rail 0 = P0_x port output is powered by V33 rail bit 6 controls the power supply of P0[6], bit 7 controls the power supply of P0[7]	0x0
5:0	-	-	Reserved	0x0

Table 645: P1_PADPWR_CTRL_REG (0x500030C2)

Bit	Mode	Symbol	Description	Reset
15:8	-	-	Reserved	0x0
7:0	R/W	P1_OUT_CTRL	1 = P1_x port output is powered by VDD1V8P rail 0 = P1_x port output is powered by V33 rail bit x controls the power supply of P1[x]	0x0

Table 646: P2_PADPWR_CTRL_REG (0x500030C4)

Bit	Mode	Symbol	Description	Reset
15:5	-	-	Reserved	0x0
4:0	R/W	P2_OUT_CTRL	1 = P2_x port output is powered by VDD1V8P rail 0 = P2_x port output is powered by V33 rail bit x controls the power supply of P2[x]	0x0

Table 647: P3_PADPWR_CTRL_REG (0x500030C6)

Bit	Mode	Symbol	Description	Reset
15:8	-	-	Reserved	0x0
7:0	R/W	P3_OUT_CTRL	1 = P3_x port output is powered by VDD1V8P rail 0 = P3_x port output is powered by V33 rail bit x controls the power supply of P3[x]	0x0

Table 648: P4_PADPWR_CTRL_REG (0x500030C8)

Bit	Mode	Symbol	Description	Reset
15:8	-	-	Reserved	0x0
7:0	R/W	P4_OUT_CTRL	1 = P4_x port output is powered by VDD1V8P rail 0 = P4_x port output is powered by V33 rail bit x controls the power supply of P4[x]	0x0

Table 649: GPIO_CLK_SEL (0x500030D0)

Bit	Mode	Symbol	Description	Reset
15:3	-	-	Reserved	0x0
2:0	R/W	FUNC_CLOCK_SEL	Select which clock to map when PID = FUNC_CLOCK. 0x0: XTAL32K 0x1: RC32K 0x2: RCX32K 0x3: XTAL16M 0x4: RC16M 0x5: DIVN 0x6: Reserved 0x7: Reserved	0x0

37.22 WDOG REGISTER FILE

Table 650: Register map WDOG

Address	Port	Description
0x50003100	WATCHDOG_REG	Watchdog timer register.
0x50003102	WATCHDOG_CTRL_REG	Watchdog control register.

Table 651: WATCHDOG_REG (0x50003100)

Bit	Mode	Symbol	Description	Reset
15:9	R0/W	WDOG_WEN	0000.000 = Write enable for Watchdog timer else Write disable. This filter prevents unintentional presetting the watchdog with a SW run-away.	0x0
8	R/W	WDOG_VAL_NEG	0 = Watchdog timer value is positive. 1 = Watchdog timer value is negative.	0x0
7:0	R/W	WDOG_VAL	Write: Watchdog timer reload value. Note that all bits 15-9 must be 0 to reload this register. Read: Actual Watchdog timer value. Decrement by 1 every 10.24 msec. Bit 8 indicates a negative counter value. 2, 1, 0, 1FF ₁₆ , 1FE ₁₆ etc. An NMI or WDOG (SYS) reset is generated under the following conditions: If WATCHDOG_CTRL_REG[NMI_RST] = 0 then if WDOG_VAL = 0 -> NMI (Non Maskable Interrupt) if WDOG_VAL = 1F0 ₁₆ -> WDOG reset -> reload FF ₁₆ If WATCHDOG_CTRL_REG[NMI_RST] = 1 then if WDOG_VAL <= 0 -> WDOG reset -> reload FF ₁₆	0xFF

Table 652: WATCHDOG_CTRL_REG (0x50003102)

Bit	Mode	Symbol	Description	Reset
15:2	-	-	Reserved	0x0
1	-	-	Reserved	0x0
0	R/W	NMI_RST	0 = Watchdog timer generates NMI at value 0, and WDOG (SYS) reset at <=-16. Timer can be frozen /resumed using SET_FREEZE_REG[FRZ_WDOG]/ RESET_FREEZE_REG[FRZ_WDOG]. 1 = Watchdog timer generates a WDOG (SYS) reset at value 0 and can not be frozen by Software. Note that this bit can only be set to 1 by SW and only be reset with a WDOG (SYS) reset or SW reset. The watchdog is always frozen when the Cortex-M0 is halted in DEBUG State.	0x0

37.23 VERSION REGISTER FILE

Table 653: Register map Version

Address	Port	Description
0x50003200	CHIP_ID1_REG	Chip identification register 1.
0x50003201	CHIP_ID2_REG	Chip identification register 2.
0x50003202	CHIP_ID3_REG	Chip identification register 3.
0x50003203	CHIP_SWC_REG	Software compatibility register.
0x50003204	CHIP_REVISION_REG	Chip revision register.

Table 654: CHIP_ID1_REG (0x50003200)

Bit	Mode	Symbol	Description	Reset
7:0	R	CHIP_ID1	First character of device type "680" in ASCII.	0x36

Table 655: CHIP_ID2_REG (0x50003201)

Bit	Mode	Symbol	Description	Reset
7:0	R	CHIP_ID2	Second character of device type "680" in ASCII.	0x38

Table 656: CHIP_ID3_REG (0x50003202)

Bit	Mode	Symbol	Description	Reset
7:0	R	CHIP_ID3	Third character of device type "680" in ASCII.	0x30

Table 657: CHIP_SWC_REG (0x50003203)

Bit	Mode	Symbol	Description	Reset
7:4	-	-	Reserved	0x0
3:0	R	CHIP_SWC	SoftWare Compatibility code. Integer (default = 0) which is incremented if a silicon change has impact on the CPU Firmware. Can be used by software developers to write silicon revision dependent code.	0x0

Table 658: CHIP_REVISION_REG (0x50003204)

Bit	Mode	Symbol	Description	Reset
7:0	R	REVISION_ID	Chip version, corresponds with type number in ASCII. 0x41 = 'A', 0x42 = 'B'	0x41

37.24 GPREG REGISTER FILE

Table 659: Register map GPREG

Address	Port	Description
0x50003300	SET_FREEZE_REG	Controls freezing of various timers/counters (incl. DMA and USB).
0x50003302	RESET_FREEZE_REG	Controls unfreezing of various timers/counters (incl. DMA and USB).
0x50003304	DEBUG_REG	Various debug information register.
0x50003306	GP_STATUS_REG	General purpose system status register.
0x50003308	GP_CONTROL_REG	General purpose system control register.
0x5000330A	ECC_BASE_ADDR_REG	Base address of the ECC Crypto memory register.
0x5000330C	LED_CONTROL_REG	Controls muxing and enabling of the LEDs.
0x50003310	PLL_SYS_CTRL1_REG	System PLL control register 1.
0x50003312	PLL_SYS_CTRL2_REG	System PLL control register 2.
0x50003314	PLL_SYS_CTRL3_REG	System PLL control register 3.
0x50003316	PLL_SYS_STATUS_REG	System PLL status register.

Table 660: SET_FREEZE_REG (0x50003300)

Bit	Mode	Symbol	Description	Reset
15:8	-	-	Reserved	0x0
7	R/W	FRZ_SWTIM2	If '1', the SW Timer (TIMER2) is frozen, '0' is discarded.	0x0
6	R/W	FRZ_SWTIM1	If '1', the SW Timer (TIMER1) is frozen, '0' is discarded.	0x0
5	R/W	FRZ_DMA	If '1', the DMA is frozen, '0' is discarded.	0x0
4	R/W	FRZ_USB	If '1', the USB is frozen, '0' is discarded.	0x0
3	R/W	FRZ_WDOG	If '1', the watchdog timer is frozen, '0' is discarded. WATCHDOG_CTRL_REG[NMI_RST] must be '0' to allow the freeze function.	0x0
2	R/W	FRZ_BLETIM	If '1', the BLE master clock is frozen, '0' is discarded.	0x0
1	R/W	FRZ_SWTIM0	If '1', the SW Timer (TIMER0) is frozen, '0' is discarded.	0x0
0	R/W	FRZ_WKUPTIM	If '1', the Wake Up Timer is frozen, '0' is discarded.	0x0

Table 661: RESET_FREEZE_REG (0x50003302)

Bit	Mode	Symbol	Description	Reset
15:8	-	-	Reserved	0x0
7	R/W	FRZ_SWTIM2	If '1', the SW Timer (TIMER2) continues, '0' is discarded.	0x0
6	R/W	FRZ_SWTIM1	If '1', the SW Timer (TIMER1) continues, '0' is discarded.	0x0
5	R/W	FRZ_DMA	If '1', the DMA continues, '0' is discarded.	0x0
4	R/W	FRZ_USB	If '1', the USB continues, '0' is discarded.	0x0
3	R/W	FRZ_WDOG	If '1', the watchdog timer continues, '0' is discarded.	0x0
2	R/W	FRZ_BLETIM	If '1', the BLE master clock continues, '0' is discarded.	0x0
1	R/W	FRZ_SWTIM0	If '1', the SW Timer (TIMER0) continues, '0' is discarded.	0x0
0	R/W	FRZ_WKUPTIM	If '1', the Wake Up Timer continues, '0' is discarded.	0x0

Table 662: DEBUG_REG (0x50003304)

Bit	Mode	Symbol	Description	Reset
15:1	-	-	Reserved	0x0

Table 662: DEBUG_REG (0x50003304)

Bit	Mode	Symbol	Description	Reset
0	R/W	DEBUGS_FREEZE_EN	Default '1', freezing of the on-chip timers is enabled when the Cortex-M0 is halted in DEBUG State. If '0', freezing of the on-chip timers is depending on FREEZE_REG when the Cortex-M0 is halted in DEBUG State <u>except</u> the watchdog timer. The watchdog timer is always frozen when the Cortex-M0 is halted in DEBUG State. Note: This bit is retained.	0x1

Table 663: GP_STATUS_REG (0x50003306)

Bit	Mode	Symbol	Description	Reset
15:1	-	-	Reserved	0x0
0	R/W	CAL_PHASE	If '1', it designates that the chip is in Calibration Phase i.e. the OTP has been initially programmed but no Calibration has occurred.	0x0

Table 664: GP_CONTROL_REG (0x50003308)

Bit	Mode	Symbol	Description	Reset
15:8	R	BLE_DEEPSLDUR_MONITOR	The 8 LSBs of the current value of the BLE Timer DEEPSLDUR. The value has been sampled by using the CPU clock.	0x0
7:3	-	-	Reserved	0x0
2	R	BLE_WAKEUP_LP_IRQ	The current value of the BLE_WAKEUP_LP_IRQ interrupt request.	0x0
1	R/W	BLE_H2H_BRIDGE_BYPASS	If '1', the AHB-to-AHB bridge is bypassed, needed to access the BLE Register file, only when the system clock source is the XTAL and both hclk and ble_hclk are running at 16MHz, i.e. at the XTAL clock rate.	0x0
0	R/W	BLE_WAKEUP_REQ	If '1', the BLE wakes up. Must be kept high at least for 1 low power clock period. If the BLE is in deep sleep state, then by setting this bit it will cause the wakeup LP IRQ to be asserted with a delay of 3 to 4 low power cycles.	0x0

Table 665: ECC_BASE_ADDR_REG (0x5000330A)

Bit	Mode	Symbol	Description	Reset
15:8	-	-	Reserved	0x0
7	-	-	Reserved	0x0
6:0	R/W	ECC_BASE_ADDR	Contains the base address of the ECC Crypto memory. Memory allocation is in pages of 1KB and up to 127KB. Since the ECC has an address range of 2KB and the total addressable memory range is 128KB, the maximum value of 0x7F (127KB offset) will result in 1KB at the top of the memory range and the other 1KB at the bottom of the memory range.	0x0

Table 666: LED_CONTROL_REG (0x5000330C)

Bit	Mode	Symbol	Description	Reset
15:6	-	-	Reserved	0x0
5	R/W	LED3_EN	0: LED3 disabled, 1: LED3 enabled.	0x0
4	R/W	LED2_EN	0: LED2 disabled, 1: LED2 enabled.	0x0
3	R/W	LED1_EN	0: LED1 disabled, 1: LED1 enabled.	0x0
2	R/W	LED3_SRC_SEL	0: LED3 = PWM4, 1: LED3 = Breathing Timer.	0x0
1	R/W	LED2_SRC_SEL	0: LED2 = PWM3, 1: LED2 = Breathing Timer.	0x0
0	R/W	LED1_SRC_SEL	0: LED1 = PWM2, 1: LED1 = Breathing Timer. Note: The PWM2/3/4 can also be routed to GPIOs using PID 25/26/27 respectively.	0x0

Table 667: PLL_SYS_CTRL1_REG (0x50003310)

Bit	Mode	Symbol	Description	Reset
15	-	-	Reserved	0x0
14:8	R/W	PLL_R_DIV	PLL Output divider R (x means divide by x, 0 means divide by 1)	0x1
7:3	-	-	Reserved	0x0
2	R/W	LDO_PLL_VREF_HO LD	0: indicates that the reference input is tracked, 1: indicates that the reference input is sampled.	0x0
1	R/W	LDO_PLL_ENABLE	0: LDO PLL off, 1: LDO PLL on.	0x0
0	R/W	PLL_EN	0: Power down 1: PLL on	0x0

Table 668: PLL_SYS_CTRL2_REG (0x50003312)

Bit	Mode	Symbol	Description	Reset
15	-	-	Reserved	0x0
14	R/W	PLL_SEL_MIN_CUR _INT	0: VCO current read from min_current <5:0>, 1: VCO current is internally determined with a calibration algorithm.	0x0
13:12	R/W	PLL_DEL_SEL	PLL manual delay value for Phase Frequency Detector. 0: 0.493 1: 0.814 2: 1.13 ns <- default 3: 1.44 ns	0x2
11:8	-	-	Reserved	0x0
7	-	-	Reserved	0x0
6:0	R/W	PLL_N_DIV	PLL Loop divider N (x means divide by x, 0 means divide by 1)	0x6

Table 669: PLL_SYS_CTRL3_REG (0x50003314)

Bit	Mode	Symbol	Description	Reset
15	R/W	PLL_RECALIB	Recalibrate	0x0
14:10	R/W	PLL_START_DEL	Programmable delay time for the loop filter voltage preset value. After PLL_EN is set, the loopfilter precharge resistors are disabled after this delay time. One LSB is 48 ns	0xF
9:5	-	-	Reserved	0x0
4:0	R/W	PLL_ICP_SEL	PLL charge pump current select One LSB is 5uA.	0x9

Table 670: PLL_SYS_STATUS_REG (0x50003316)

Bit	Mode	Symbol	Description	Reset
15:12	-	-	Reserved	0x0
11	R	PLL_CALIBR_END	Indicates that calibration has finished.	0x0
10:5	R	PLL_PLL_BEST_MIN_CUR	Calibrated VCO frequency band.	0x0
4:2	-	-	Reserved	0x0
1	R	LDO_PLL_OK	1: Indicates that LDO PLL is in regulation.	0x0
0	R	PLL_LOCK_FINE	1: PLL locked	0x0

37.25 TIMER0/2 AND BREATH REGISTER FILE

Table 671: Register map Timer0/2 and Breath

Address	Port	Description
0x50003400	TIMER0_CTRL_REG	Timer0 control register
0x50003402	TIMER0_ON_REG	Timer0 on control register
0x50003404	TIMER0_RELOAD_M_REG	16 bits reload value for Timer0
0x50003406	TIMER0_RELOAD_N_REG	16 bits reload value for Timer0
0x50003408	PWM2_START_CYCLE	Defines start Cycle for PWM2
0x5000340A	PWM3_START_CYCLE	Defines start Cycle for PWM3
0x5000340C	PWM4_START_CYCLE	Defines start Cycle for PWM4
0x5000340E	PWM2_END_CYCLE	Defines end Cycle for PWM2
0x50003410	PWM3_END_CYCLE	Defines end Cycle for PWM3
0x50003412	PWM4_END_CYCLE	Defines end Cycle for PWM4
0x50003414	TRIPLE_PWM_FREQUENCY	Defines the PMW2,3,4 frequency
0x50003416	TRIPLE_PWM_CTRL_REG	PWM 2 3 4 Control register
0x50003418	BREATH_CFG_REG	Breath configuration register
0x5000341A	BREATH_DUTY_MAX_REG	Breath max duty cycle register
0x5000341C	BREATH_DUTY_MIN_REG	Breath min duty cycle register
0x5000341E	BREATH_CTRL_REG	Breath control register

Table 672: TIMER0_CTRL_REG (0x50003400)

Bit	Mode	Symbol	Description	Reset
15:4	-	-	Reserved	0x0
3	R/W	PWM_MODE	0 = PWM signals are '1' during high time. 1 = PWM signals send out the (fast) clock divided by 2 during high time.	0x0
2	R/W	TIM0_CLK_DIV	1 = Timer0 uses selected clock frequency as is. 0 = Timer0 uses selected clock frequency divided by 10. Note that this applies only to the ON-counter.	0x0
1	R/W	TIM0_CLK_SEL	1 = Timer0 uses fast clock frequency. 0 = Timer0 uses 32 kHz (slow) clock frequency.	0x0
0	R/W	TIM0_CTRL	0 = Timer0 is off and in reset state. 1 = Timer0 is running.	0x0

Table 673: TIMER0_ON_REG (0x50003402)

Bit	Mode	Symbol	Description	Reset
15:0	R0/W	TIM0_ON	Timer0 On reload value: If read the actual counter value ON_CNTER is returned	0x0

Table 674: TIMER0_RELOAD_M_REG (0x50003404)

Bit	Mode	Symbol	Description	Reset
15:0	R0/W	TIM0_M	Timer0 'high' reload value If read the actual counter value T0_CNTER is returned	0x0

Table 675: TIMER0_RELOAD_N_REG (0x50003406)

Bit	Mode	Symbol	Description	Reset
15:0	R0/W	TIM0_N	Timer0 'low' reload value: If read the actual counter value T0_CNTER is returned	0x0

Table 676: PWM2_START_CYCLE (0x50003408)

Bit	Mode	Symbol	Description	Reset
13:0	R/W	START_CYCLE	Define the cycle in which the PWM becomes high. if start_cycle larger than freq or end and start are equal, pwm out is always 0	0x0

Table 677: PWM3_START_CYCLE (0x5000340A)

Bit	Mode	Symbol	Description	Reset
13:0	R/W	START_CYCLE	Define the cycle in which the PWM becomes high. if start_cycle larger than freq or end and start are equal, pwm out is always 0	0x0

Table 678: PWM4_START_CYCLE (0x5000340C)

Bit	Mode	Symbol	Description	Reset
13:0	R/W	START_CYCLE	Define the cycle in which the PWM becomes high. if start_cycle larger than freq or end and start are equal, pwm out is always 0	0x0

Table 679: PWM2_END_CYCLE (0x5000340E)

Bit	Mode	Symbol	Description	Reset
13:0	R/W	END_CYCLE	Define the cycle in which the PWM becomes low. If end cycle larger then freq pwm and start cycle not larger then freq pwm, output is always 1	0x0

Table 680: PWM3_END_CYCLE (0x50003410)

Bit	Mode	Symbol	Description	Reset
13:0	R/W	END_CYCLE	Define the cycle in which the PWM becomes low. If end cycle larger then freq pwm and start cycle not larger then freq pwm, output is always 1	0x0

Table 681: PWM4_END_CYCLE (0x50003412)

Bit	Mode	Symbol	Description	Reset
13:0	R/W	END_CYCLE	Define the cycle in which the PWM becomes low. If end cycle larger then freq pwm and start cycle not larger then freq pwm, output is always 1	0x0

Table 682: TRIPLE_PWM_FREQUENCY (0x50003414)

Bit	Mode	Symbol	Description	Reset
13:0	R/W	FREQ	Freq for PWM 2 3 4, period = timer_clk * (FREQ+1)	0x0

Table 683: TRIPLE_PWM_CTRL_REG (0x50003416)

Bit	Mode	Symbol	Description	Reset
2	R/W	HW_PAUSE_EN	'1' = HW can pause PWM 2,3,4	0x1
1	R/W	SW_PAUSE_EN	'1' = PWM 2 3 4 is paused	0x0
0	R/W	TRIPLE_PWM_ENA BLE	'1' = PWM 2 3 4 is enabled	0x0

Table 684: BREATH_CFG_REG (0x50003418)

Bit	Mode	Symbol	Description	Reset
15:8	R/W	BRTH_STEP	Defines the number of PWM periods minus 1, duty cycle will be changed	0x1
7:0	R/W	BRTH_DIV	Defines the division factor of the system clock to get to the PWM frequency.(= Sys Clock / (value+1)	0xFF

Table 685: BREATH_DUTY_MAX_REG (0x5000341A)

Bit	Mode	Symbol	Description	Reset
7:0	R/W	BRTH_DUTY_MAX	Defines the maximum duty cycle of the PWM breath function. Duty cycle = value / (brth_div+1)	0xA

Table 686: BREATH_DUTY_MIN_REG (0x5000341C)

Bit	Mode	Symbol	Description	Reset
7:0	R/W	BRTH_DUTY_MIN	Defines the minimum duty cycle of the PWM breath function. Duty cycle = value / (brth_div+1)	0x1

Table 687: BREATH_CTRL_REG (0x5000341E)

Bit	Mode	Symbol	Description	Reset
1	R/W	BRTH_PWM_POL	Define the output polarity.	0x0
0	R/W	BRTH_EN	'1' enable the Breath operation	0x0

37.26 DMA REGISTER FILE

Table 688: Register map DMA

Address	Port	Description
0x50003500	DMA0_A_STARTL_REG	Start address Low A of DMA channel 0
0x50003502	DMA0_A_STARTH_REG	Start address High A of DMA channel 0
0x50003504	DMA0_B_STARTL_REG	Start address Low B of DMA channel 0
0x50003506	DMA0_B_STARTH_REG	Start address High B of DMA channel 0
0x50003508	DMA0_INT_REG	DMA receive interrupt register channel 0
0x5000350A	DMA0_LEN_REG	DMA receive length register channel 0
0x5000350C	DMA0_CTRL_REG	Control register for the DMA channel 0
0x5000350E	DMA0_IDX_REG	Index value of DMA channel 0
0x50003510	DMA1_A_STARTL_REG	Start address Low A of DMA channel 1
0x50003512	DMA1_A_STARTH_REG	Start address High A of DMA channel 1
0x50003514	DMA1_B_STARTL_REG	Start address Low B of DMA channel 1
0x50003516	DMA1_B_STARTH_REG	Start address High B of DMA channel 1
0x50003518	DMA1_INT_REG	DMA receive interrupt register channel 1
0x5000351A	DMA1_LEN_REG	DMA receive length register channel 1
0x5000351C	DMA1_CTRL_REG	Control register for the DMA channel 1
0x5000351E	DMA1_IDX_REG	Index value of DMA channel 1
0x50003520	DMA2_A_STARTL_REG	Start address Low A of DMA channel 2
0x50003522	DMA2_A_STARTH_REG	Start address High A of DMA channel 2
0x50003524	DMA2_B_STARTL_REG	Start address Low B of DMA channel 2
0x50003526	DMA2_B_STARTH_REG	Start address High B of DMA channel 2
0x50003528	DMA2_INT_REG	DMA receive interrupt register channel 2
0x5000352A	DMA2_LEN_REG	DMA receive length register channel 2
0x5000352C	DMA2_CTRL_REG	Control register for the DMA channel 2
0x5000352E	DMA2_IDX_REG	Index value of DMA channel 2
0x50003530	DMA3_A_STARTL_REG	Start address Low A of DMA channel 3
0x50003532	DMA3_A_STARTH_REG	Start address High A of DMA channel 3
0x50003534	DMA3_B_STARTL_REG	Start address Low B of DMA channel 3
0x50003536	DMA3_B_STARTH_REG	Start address High B of DMA channel 3
0x50003538	DMA3_INT_REG	DMA receive interrupt register channel 3
0x5000353A	DMA3_LEN_REG	DMA receive length register channel 3
0x5000353C	DMA3_CTRL_REG	Control register for the DMA channel 3
0x5000353E	DMA3_IDX_REG	Index value of DMA channel 3
0x50003540	DMA4_A_STARTL_REG	Start address Low A of DMA channel 4
0x50003542	DMA4_A_STARTH_REG	Start address High A of DMA channel 4
0x50003544	DMA4_B_STARTL_REG	Start address Low B of DMA channel 4
0x50003546	DMA4_B_STARTH_REG	Start address High B of DMA channel 4
0x50003548	DMA4_INT_REG	DMA receive interrupt register channel 4
0x5000354A	DMA4_LEN_REG	DMA receive length register channel 4
0x5000354C	DMA4_CTRL_REG	Control register for the DMA channel 4
0x5000354E	DMA4_IDX_REG	Index value of DMA channel 4
0x50003550	DMA5_A_STARTL_REG	Start address Low A of DMA channel 5
0x50003552	DMA5_A_STARTH_REG	Start address High A of DMA channel 5
0x50003554	DMA5_B_STARTL_REG	Start address Low B of DMA channel 5

Table 688: Register map DMA

Address	Port	Description
0x50003556	DMA5_B_STARTH_REG	Start address High B of DMA channel 5
0x50003558	DMA5_INT_REG	DMA receive interrupt register channel 5
0x5000355A	DMA5_LEN_REG	DMA receive length register channel 5
0x5000355C	DMA5_CTRL_REG	Control register for the DMA channel 5
0x5000355E	DMA5_IDX_REG	Index value of DMA channel 5
0x50003560	DMA6_A_STARTL_REG	Start address Low A of DMA channel 6
0x50003562	DMA6_A_STARTH_REG	Start address High A of DMA channel 6
0x50003564	DMA6_B_STARTL_REG	Start address Low B of DMA channel 6
0x50003566	DMA6_B_STARTH_REG	Start address High B of DMA channel 6
0x50003568	DMA6_INT_REG	DMA receive interrupt register channel 6
0x5000356A	DMA6_LEN_REG	DMA receive length register channel 6
0x5000356C	DMA6_CTRL_REG	Control register for the DMA channel 6
0x5000356E	DMA6_IDX_REG	Index value of DMA channel 6
0x50003570	DMA7_A_STARTL_REG	Start address Low A of DMA channel 7
0x50003572	DMA7_A_STARTH_REG	Start address High A of DMA channel 7
0x50003574	DMA7_B_STARTL_REG	Start address Low B of DMA channel 7
0x50003576	DMA7_B_STARTH_REG	Start address High B of DMA channel 7
0x50003578	DMA7_INT_REG	DMA receive interrupt register channel 7
0x5000357A	DMA7_LEN_REG	DMA receive length register channel 7
0x5000357C	DMA7_CTRL_REG	Control register for the DMA channel 7
0x5000357E	DMA7_IDX_REG	Index value of DMA channel 7
0x50003580	DMA_REQ_MUX_REG	DMA channel assignments
0x50003582	DMA_INT_STATUS_REG	DMA interrupt status register
0x50003584	DMA_CLEAR_INT_REG	DMA clear interrupt register

Table 689: DMA0_A_STARTL_REG (0x50003500)

Bit	Mode	Symbol	Description	Reset
15:0	R/W	DMA0_A_STARTL	Source start address, lower 16 bits	0x0

Table 690: DMA0_A_STARTH_REG (0x50003502)

Bit	Mode	Symbol	Description	Reset
15:0	R/W	DMA0_A_STARTH	Source start address, upper 16 bits	0x0

Table 691: DMA0_B_STARTL_REG (0x50003504)

Bit	Mode	Symbol	Description	Reset
15:0	R/W	DMA0_B_STARTL	Destination start address, lower 16 bits	0x0

Table 692: DMA0_B_STARTH_REG (0x50003506)

Bit	Mode	Symbol	Description	Reset
15:0	R/W	DMA0_B_STARTH	Destination start address, upper 16 bits	0x0

Table 693: DMA0_INT_REG (0x50003508)

Bit	Mode	Symbol	Description	Reset
15:0	R/W	DMA0_INT	Number of transfers until an interrupt is generated. The interrupt is generated after a transfer, if DMAx_INT_REG is equal to DMAx_IDX_REG and before DMAx_IDX_REG is incremented. The bit-field IRQ_ENABLE of DMAx_CTRL_REG must be set to '1' to let the controller generate the interrupt.	0x0

Table 694: DMA0_LEN_REG (0x5000350A)

Bit	Mode	Symbol	Description	Reset
15:0	R/W	DMA0_LEN	DMA channel's transfer length. DMAx_LEN of value 0, 1, 2, ... results into an actual transfer length of 1, 2, 3, ...	0x0

Table 695: DMA0_CTRL_REG (0x5000350C)

Bit	Mode	Symbol	Description	Reset
15:13	-	-	Reserved	0x0
12	R/W	DMA_INIT	0 = DMA performs copy A1 to B1, A2 to B2, etc ... 1 = DMA performs copy of A1 to B1, B2, etc ... This feature is useful for memory initialization to any value. Thus, BINC must be set to '1', while AINC is don't care, as only one fetch from A is done. This process cannot be interrupted by other DMA channels. It is also noted that DMA_INIT should not be used when DREQ_MODE='1'.	0x0
11	R/W	DMA_IDLE	0 = Blocking mode, the DMA performs a fast back-to-back copy, disabling bus access for any bus master with lower priority. 1 = Interrupting mode, the DMA inserts a wait cycle after each store allowing the CPU to steal cycles or cache to perform a burst read. If DREQ_MODE='1', DMA_IDLE is don't care.	0x0
10:8	R/W	DMA_PRIO	The priority level determines which DMA channel will be granted access for transferring data, in case more than one channels are active and request the bus at the same time. The greater the value, the higher the priority. In specific: 000 = lowest priority 111 = highest priority If different channels with equal priority level values request the bus at the same time, an inherent priority mechanism is applied. According to this mechanism, if, for example, both the DMA0 and DMA1 channels have the same priority level, then DMA0 will first be granted access to the bus.	0x0
7	R/W	CIRCULAR	0 = Normal mode. The DMA channel stops after having completed the transfer of length determined by DMAx_LEN_REG. DMA_ON automatically deasserts when the transfer is completed. 1 = Circular mode (applicable only if DREQ_MODE = '1'). In this mode, DMA_ON never deasserts, as the DMA channel automatically resets DMAx_IDX_REG and starts a new transfer.	0x0
6	R/W	AINC	Enable increment of source address. 0 = do not increment (source address stays the same during the transfer) 1 = increment according to the value of BW bit-field (by 1, when BW="00"; by 2, when BW="01"; by 4, when BW="10")	0x0

Table 695: DMA0_CTRL_REG (0x5000350C)

Bit	Mode	Symbol	Description	Reset
5	R/W	BINC	Enable increment of destination address. 0 = do not increment (destination address stays the same during the transfer) 1 = increment according to the value of BW bit-field (by 1, when BW="00" ; by 2, when BW="01" ; by 4, when BW="10")	0x0
4	R/W	DREQ_MODE	0 = DMA channel starts immediately 1 = DMA channel must be triggered by peripheral DMA request (see also the description of DMA_REQ_MUX_REG)	0x0
3	R/W	IRQ_ENABLE	0 = disables interrupts on this channel 1 = enables interrupts on this channel	0x0
2:1	R/W	BW	Bus transfer width: 00 = 1 Byte (suggested for peripherals like UART and 8-bit SPI) 01 = 2 Bytes (suggested for peripherals like I2C and 16-bit SPI) 10 = 4 Bytes (suggested for Memory-to-Memory transfers) 11 = Reserved	0x0
0	R/W	DMA_ON	0 = DMA channel is off, clocks are disabled 1 = DMA channel is enabled. This bit will be automatically cleared after the completion of a transfer, if circular mode is not enabled. In circular mode, this bit stays set.	0x0

Table 696: DMA0_IDX_REG (0x5000350E)

Bit	Mode	Symbol	Description	Reset
15:0	R	DMA0_IDX	This (read-only) register determines the data items currently fetched by the DMA channel, during an on-going transfer. When the transfer is completed, the register is automatically reset to 0. The DMA channel uses this register to form the source/destination address of the next DMA cycle, considering also AINC/BINC and BW.	0x0

Table 697: DMA1_A_STARTL_REG (0x50003510)

Bit	Mode	Symbol	Description	Reset
15:0	R/W	DMA1_A_STARTL	Source start address, lower 16 bits	0x0

Table 698: DMA1_A_STARTH_REG (0x50003512)

Bit	Mode	Symbol	Description	Reset
15:0	R/W	DMA1_A_STARTH	Source start address, upper 16 bits	0x0

Table 699: DMA1_B_STARTL_REG (0x50003514)

Bit	Mode	Symbol	Description	Reset
15:0	R/W	DMA1_B_STARTL	Destination start address, lower 16 bits	0x0

Table 700: DMA1_B_STARTH_REG (0x50003516)

Bit	Mode	Symbol	Description	Reset
15:0	R/W	DMA1_B_STARTH	Destination start address, upper 16 bits	0x0

Table 701: DMA1_INT_REG (0x50003518)

Bit	Mode	Symbol	Description	Reset
15:0	R/W	DMA1_INT	Number of transfers until an interrupt is generated. The interrupt is generated after a transfer, if DMAx_INT_REG is equal to DMAx_IDX_REG and before DMAx_IDX_REG is incremented. The bit-field IRQ_ENABLE of DMAx_CTRL_REG must be set to '1' to let the controller generate the interrupt.	0x0

Table 702: DMA1_LEN_REG (0x5000351A)

Bit	Mode	Symbol	Description	Reset
15:0	R/W	DMA1_LEN	DMA channel's transfer length. DMAx_LEN of value 0, 1, 2, ... results into an actual transfer length of 1, 2, 3, ...	0x0

Table 703: DMA1_CTRL_REG (0x5000351C)

Bit	Mode	Symbol	Description	Reset
15:13	-	-	Reserved	0x0
12	R/W	DMA_INIT	0 = DMA performs copy A1 to B1, A2 to B2, etc ... 1 = DMA performs copy of A1 to B1, B2, etc ... This feature is useful for memory initialization to any value. Thus, BINC must be set to '1', while AINC is don't care, as only one fetch from A is done. This process cannot be interrupted by other DMA channels. It is also noted that DMA_INIT should not be used when DREQ_MODE='1'.	0x0
11	R/W	DMA_IDLE	0 = Blocking mode, the DMA performs a fast back-to-back copy, disabling bus access for any bus master with lower priority. 1 = Interrupting mode, the DMA inserts a wait cycle after each store allowing the CPU to steal cycles or cache to perform a burst read. If DREQ_MODE='1', DMA_IDLE is don't care.	0x0
10:8	R/W	DMA_PRIO	The priority level determines which DMA channel will be granted access for transferring data, in case more than one channels are active and request the bus at the same time. The greater the value, the higher the priority. In specific: 000 = lowest priority 111 = highest priority If different channels with equal priority level values request the bus at the same time, an inherent priority mechanism is applied. According to this mechanism, if, for example, both the DMA0 and DMA1 channels have the same priority level, then DMA0 will first be granted access to the bus.	0x0
7	R/W	CIRCULAR	0 = Normal mode. The DMA channel stops after having completed the transfer of length determined by DMAx_LEN_REG. DMA_ON automatically deasserts when the transfer is completed. 1 = Circular mode (applicable only if DREQ_MODE = '1'). In this mode, DMA_ON never deasserts, as the DMA channel automatically resets DMAx_IDX_REG and starts a new transfer.	0x0
6	R/W	AINC	Enable increment of source address. 0 = do not increment (source address stays the same during the transfer) 1 = increment according to the value of BW bit-field (by 1, when BW="00"; by 2, when BW="01"; by 4, when BW="10")	0x0

Table 703: DMA1_CTRL_REG (0x5000351C)

Bit	Mode	Symbol	Description	Reset
5	R/W	BINC	Enable increment of destination address. 0 = do not increment (destination address stays the same during the transfer) 1 = increment according to the value of BW bit-field (by 1, when BW="00" ; by 2, when BW="01" ; by 4, when BW="10")	0x0
4	R/W	DREQ_MODE	0 = DMA channel starts immediately 1 = DMA channel must be triggered by peripheral DMA request (see also the description of DMA_REQ_MUX_REG)	0x0
3	R/W	IRQ_ENABLE	0 = disables interrupts on this channel 1 = enables interrupts on this channel	0x0
2:1	R/W	BW	Bus transfer width: 00 = 1 Byte (suggested for peripherals like UART and 8-bit SPI) 01 = 2 Bytes (suggested for peripherals like I2C and 16-bit SPI) 10 = 4 Bytes (suggested for Memory-to-Memory transfers) 11 = Reserved	0x0
0	R/W	DMA_ON	0 = DMA channel is off, clocks are disabled 1 = DMA channel is enabled. This bit will be automatically cleared after the completion of a transfer, if circular mode is not enabled. In circular mode, this bit stays set.	0x0

Table 704: DMA1_IDX_REG (0x5000351E)

Bit	Mode	Symbol	Description	Reset
15:0	R	DMA1_IDX	This (read-only) register determines the data items currently fetched by the DMA channel, during an on-going transfer. When the transfer is completed, the register is automatically reset to 0. The DMA channel uses this register to form the source/destination address of the next DMA cycle, considering also AINC/BINC and BW.	0x0

Table 705: DMA2_A_STARTL_REG (0x50003520)

Bit	Mode	Symbol	Description	Reset
15:0	R/W	DMA2_A_STARTL	Source start address, lower 16 bits	0x0

Table 706: DMA2_A_STARTH_REG (0x50003522)

Bit	Mode	Symbol	Description	Reset
15:0	R/W	DMA2_A_STARTH	Source start address, upper 16 bits	0x0

Table 707: DMA2_B_STARTL_REG (0x50003524)

Bit	Mode	Symbol	Description	Reset
15:0	R/W	DMA2_B_STARTL	Destination start address, lower 16 bits	0x0

Table 708: DMA2_B_STARTH_REG (0x50003526)

Bit	Mode	Symbol	Description	Reset
15:0	R/W	DMA2_B_STARTH	Destination start address, upper 16 bits	0x0

Table 709: DMA2_INT_REG (0x50003528)

Bit	Mode	Symbol	Description	Reset
15:0	R/W	DMA2_INT	Number of transfers until an interrupt is generated. The interrupt is generated after a transfer, if DMA2_INT_REG is equal to DMAx_IDX_REG and before DMAx_IDX_REG is incremented. The bit-field IRQ_ENABLE of DMAx_CTRL_REG must be set to '1' to let the controller generate the interrupt.	0x0

Table 710: DMA2_LEN_REG (0x5000352A)

Bit	Mode	Symbol	Description	Reset
15:0	R/W	DMA2_LEN	DMA channel's transfer length. DMAx_LEN of value 0, 1, 2, ... results into an actual transfer length of 1, 2, 3, ...	0x0

Table 711: DMA2_CTRL_REG (0x5000352C)

Bit	Mode	Symbol	Description	Reset
15:13	-	-	Reserved	0x0
12	R/W	DMA_INIT	0 = DMA performs copy A1 to B1, A2 to B2, etc ... 1 = DMA performs copy of A1 to B1, B2, etc ... This feature is useful for memory initialization to any value. Thus, BINC must be set to '1', while AINC is don't care, as only one fetch from A is done. This process cannot be interrupted by other DMA channels. It is also noted that DMA_INIT should not be used when DREQ_MODE='1'.	0x0
11	R/W	DMA_IDLE	0 = Blocking mode, the DMA performs a fast back-to-back copy, disabling bus access for any bus master with lower priority. 1 = Interrupting mode, the DMA inserts a wait cycle after each store allowing the CPU to steal cycles or cache to perform a burst read. If DREQ_MODE='1', DMA_IDLE is don't care.	0x0
10:8	R/W	DMA_PRIO	The priority level determines which DMA channel will be granted access for transferring data, in case more than one channels are active and request the bus at the same time. The greater the value, the higher the priority. In specific: 000 = lowest priority 111 = highest priority If different channels with equal priority level values request the bus at the same time, an inherent priority mechanism is applied. According to this mechanism, if, for example, both the DMA0 and DMA1 channels have the same priority level, then DMA0 will first be granted access to the bus.	0x0
7	R/W	CIRCULAR	0 = Normal mode. The DMA channel stops after having completed the transfer of length determined by DMAx_LEN_REG. DMA_ON automatically deasserts when the transfer is completed. 1 = Circular mode (applicable only if DREQ_MODE = '1'). In this mode, DMA_ON never deasserts, as the DMA channel automatically resets DMAx_IDX_REG and starts a new transfer.	0x0
6	R/W	AINC	Enable increment of source address. 0 = do not increment (source address stays the same during the transfer) 1 = increment according to the value of BW bit-field (by 1, when BW="00" ; by 2, when BW="01" ; by 4, when BW="10")	0x0

Table 711: DMA2_CTRL_REG (0x5000352C)

Bit	Mode	Symbol	Description	Reset
5	R/W	BINC	Enable increment of destination address. 0 = do not increment (destination address stays the same during the transfer) 1 = increment according to the value of BW bit-field (by 1, when BW="00" ; by 2, when BW="01" ; by 4, when BW="10")	0x0
4	R/W	DREQ_MODE	0 = DMA channel starts immediately 1 = DMA channel must be triggered by peripheral DMA request (see also the description of DMA_REQ_MUX_REG)	0x0
3	R/W	IRQ_ENABLE	0 = disables interrupts on this channel 1 = enables interrupts on this channel	0x0
2:1	R/W	BW	Bus transfer width: 00 = 1 Byte (suggested for peripherals like UART and 8-bit SPI) 01 = 2 Bytes (suggested for peripherals like I2C and 16-bit SPI) 10 = 4 Bytes (suggested for Memory-to-Memory transfers) 11 = Reserved	0x0
0	R/W	DMA_ON	0 = DMA channel is off, clocks are disabled 1 = DMA channel is enabled. This bit will be automatically cleared after the completion of a transfer, if circular mode is not enabled. In circular mode, this bit stays set.	0x0

Table 712: DMA2_IDX_REG (0x5000352E)

Bit	Mode	Symbol	Description	Reset
15:0	R	DMA2_IDX	This (read-only) register determines the data items currently fetched by the DMA channel, during an on-going transfer. When the transfer is completed, the register is automatically reset to 0. The DMA channel uses this register to form the source/destination address of the next DMA cycle, considering also AINC/BINC and BW.	0x0

Table 713: DMA3_A_STARTL_REG (0x50003530)

Bit	Mode	Symbol	Description	Reset
15:0	R/W	DMA3_A_STARTL	Source start address, lower 16 bits	0x0

Table 714: DMA3_A_STARTH_REG (0x50003532)

Bit	Mode	Symbol	Description	Reset
15:0	R/W	DMA3_A_STARTH	Source start address, upper 16 bits	0x0

Table 715: DMA3_B_STARTL_REG (0x50003534)

Bit	Mode	Symbol	Description	Reset
15:0	R/W	DMA3_B_STARTL	Destination start address, lower 16 bits	0x0

Table 716: DMA3_B_STARTH_REG (0x50003536)

Bit	Mode	Symbol	Description	Reset
15:0	R/W	DMA3_B_STARTH	Destination start address, upper 16 bits	0x0

Table 717: DMA3_INT_REG (0x50003538)

Bit	Mode	Symbol	Description	Reset
15:0	R/W	DMA3_INT	Number of transfers until an interrupt is generated. The interrupt is generated after a transfer, if DMA3_INT_REG is equal to DMAx_IDX_REG and before DMAx_IDX_REG is incremented. The bit-field IRQ_ENABLE of DMAx_CTRL_REG must be set to '1' to let the controller generate the interrupt.	0x0

Table 718: DMA3_LEN_REG (0x5000353A)

Bit	Mode	Symbol	Description	Reset
15:0	R/W	DMA3_LEN	DMA channel's transfer length. DMAx_LEN of value 0, 1, 2, ... results into an actual transfer length of 1, 2, 3, ...	0x0

Table 719: DMA3_CTRL_REG (0x5000353C)

Bit	Mode	Symbol	Description	Reset
15:13	-	-	Reserved	0x0
12	R/W	DMA_INIT	0 = DMA performs copy A1 to B1, A2 to B2, etc ... 1 = DMA performs copy of A1 to B1, B2, etc ... This feature is useful for memory initialization to any value. Thus, BINC must be set to '1', while AINC is don't care, as only one fetch from A is done. This process cannot be interrupted by other DMA channels. It is also noted that DMA_INIT should not be used when DREQ_MODE='1'.	0x0
11	R/W	DMA_IDLE	0 = Blocking mode, the DMA performs a fast back-to-back copy, disabling bus access for any bus master with lower priority. 1 = Interrupting mode, the DMA inserts a wait cycle after each store allowing the CPU to steal cycles or cache to perform a burst read. If DREQ_MODE='1', DMA_IDLE is don't care.	0x0
10:8	R/W	DMA_PRIO	The priority level determines which DMA channel will be granted access for transferring data, in case more than one channels are active and request the bus at the same time. The greater the value, the higher the priority. In specific: 000 = lowest priority 111 = highest priority If different channels with equal priority level values request the bus at the same time, an inherent priority mechanism is applied. According to this mechanism, if, for example, both the DMA0 and DMA1 channels have the same priority level, then DMA0 will first be granted access to the bus.	0x0
7	R/W	CIRCULAR	0 = Normal mode. The DMA channel stops after having completed the transfer of length determined by DMAx_LEN_REG. DMA_ON automatically deasserts when the transfer is completed. 1 = Circular mode (applicable only if DREQ_MODE = '1'). In this mode, DMA_ON never deasserts, as the DMA channel automatically resets DMAx_IDX_REG and starts a new transfer.	0x0
6	R/W	AINC	Enable increment of source address. 0 = do not increment (source address stays the same during the transfer) 1 = increment according to the value of BW bit-field (by 1, when BW="00"; by 2, when BW="01"; by 4, when BW="10")	0x0

Table 719: DMA3_CTRL_REG (0x5000353C)

Bit	Mode	Symbol	Description	Reset
5	R/W	BINC	Enable increment of destination address. 0 = do not increment (destination address stays the same during the transfer) 1 = increment according to the value of BW bit-field (by 1, when BW="00" ; by 2, when BW="01" ; by 4, when BW="10")	0x0
4	R/W	DREQ_MODE	0 = DMA channel starts immediately 1 = DMA channel must be triggered by peripheral DMA request (see also the description of DMA_REQ_MUX_REG)	0x0
3	R/W	IRQ_ENABLE	0 = disables interrupts on this channel 1 = enables interrupts on this channel	0x0
2:1	R/W	BW	Bus transfer width: 00 = 1 Byte (suggested for peripherals like UART and 8-bit SPI) 01 = 2 Bytes (suggested for peripherals like I2C and 16-bit SPI) 10 = 4 Bytes (suggested for Memory-to-Memory transfers) 11 = Reserved	0x0
0	R/W	DMA_ON	0 = DMA channel is off, clocks are disabled 1 = DMA channel is enabled. This bit will be automatically cleared after the completion of a transfer, if circular mode is not enabled. In circular mode, this bit stays set.	0x0

Table 720: DMA3_IDX_REG (0x5000353E)

Bit	Mode	Symbol	Description	Reset
15:0	R	DMA3_IDX	This (read-only) register determines the data items currently fetched by the DMA channel, during an on-going transfer. When the transfer is completed, the register is automatically reset to 0. The DMA channel uses this register to form the source/destination address of the next DMA cycle, considering also AINC/BINC and BW.	0x0

Table 721: DMA4_A_STARTL_REG (0x50003540)

Bit	Mode	Symbol	Description	Reset
15:0	R/W	DMA4_A_STARTL	Source start address, lower 16 bits	0x0

Table 722: DMA4_A_STARTH_REG (0x50003542)

Bit	Mode	Symbol	Description	Reset
15:0	R/W	DMA4_A_STARTH	Source start address, upper 16 bits	0x0

Table 723: DMA4_B_STARTL_REG (0x50003544)

Bit	Mode	Symbol	Description	Reset
15:0	R/W	DMA4_B_STARTL	Destination start address, lower 16 bits	0x0

Table 724: DMA4_B_STARTH_REG (0x50003546)

Bit	Mode	Symbol	Description	Reset
15:0	R/W	DMA4_B_STARTH	Destination start address, upper 16 bits	0x0

Table 725: DMA4_INT_REG (0x50003548)

Bit	Mode	Symbol	Description	Reset
15:0	R/W	DMA4_INT	Number of transfers until an interrupt is generated. The interrupt is generated after a transfer, if DMA4_INT_REG is equal to DMAx_IDX_REG and before DMAx_IDX_REG is incremented. The bit-field IRQ_ENABLE of DMAx_CTRL_REG must be set to '1' to let the controller generate the interrupt.	0x0

Table 726: DMA4_LEN_REG (0x5000354A)

Bit	Mode	Symbol	Description	Reset
15:0	R/W	DMA4_LEN	DMA channel's transfer length. DMAx_LEN of value 0, 1, 2, ... results into an actual transfer length of 1, 2, 3, ...	0x0

Table 727: DMA4_CTRL_REG (0x5000354C)

Bit	Mode	Symbol	Description	Reset
15:13	-	-	Reserved	0x0
12	R/W	DMA_INIT	0 = DMA performs copy A1 to B1, A2 to B2, etc ... 1 = DMA performs copy of A1 to B1, B2, etc ... This feature is useful for memory initialization to any value. Thus, BINC must be set to '1', while AINC is don't care, as only one fetch from A is done. This process cannot be interrupted by other DMA channels. It is also noted that DMA_INIT should not be used when DREQ_MODE='1'.	0x0
11	R/W	DMA_IDLE	0 = Blocking mode, the DMA performs a fast back-to-back copy, disabling bus access for any bus master with lower priority. 1 = Interrupting mode, the DMA inserts a wait cycle after each store allowing the CPU to steal cycles or cache to perform a burst read. If DREQ_MODE='1', DMA_IDLE is don't care.	0x0
10:8	R/W	DMA_Prio	The priority level determines which DMA channel will be granted access for transferring data, in case more than one channels are active and request the bus at the same time. The greater the value, the higher the priority. In specific: 000 = lowest priority 111 = highest priority If different channels with equal priority level values request the bus at the same time, an inherent priority mechanism is applied. According to this mechanism, if, for example, both the DMA0 and DMA1 channels have the same priority level, then DMA0 will first be granted access to the bus.	0x0
7	R/W	CIRCULAR	0 = Normal mode. The DMA channel stops after having completed the transfer of length determined by DMAx_LEN_REG. DMA_ON automatically deasserts when the transfer is completed. 1 = Circular mode (applicable only if DREQ_MODE = '1'). In this mode, DMA_ON never deasserts, as the DMA channel automatically resets DMAx_IDX_REG and starts a new transfer.	0x0
6	R/W	AINC	Enable increment of source address. 0 = do not increment (source address stays the same during the transfer) 1 = increment according to the value of BW bit-field (by 1, when BW="00" ; by 2, when BW="01" ; by 4, when BW="10")	0x0

Table 727: DMA4_CTRL_REG (0x5000354C)

Bit	Mode	Symbol	Description	Reset
5	R/W	BINC	Enable increment of destination address. 0 = do not increment (destination address stays the same during the transfer) 1 = increment according to the value of BW bit-field (by 1, when BW="00" ; by 2, when BW="01" ; by 4, when BW="10")	0x0
4	R/W	DREQ_MODE	0 = DMA channel starts immediately 1 = DMA channel must be triggered by peripheral DMA request (see also the description of DMA_REQ_MUX_REG)	0x0
3	R/W	IRQ_ENABLE	0 = disables interrupts on this channel 1 = enables interrupts on this channel	0x0
2:1	R/W	BW	Bus transfer width: 00 = 1 Byte (suggested for peripherals like UART and 8-bit SPI) 01 = 2 Bytes (suggested for peripherals like I2C and 16-bit SPI) 10 = 4 Bytes (suggested for Memory-to-Memory transfers) 11 = Reserved	0x0
0	R/W	DMA_ON	0 = DMA channel is off, clocks are disabled 1 = DMA channel is enabled. This bit will be automatically cleared after the completion of a transfer, if circular mode is not enabled. In circular mode, this bit stays set.	0x0

Table 728: DMA4_IDX_REG (0x5000354E)

Bit	Mode	Symbol	Description	Reset
15:0	R	DMA4_IDX	This (read-only) register determines the data items currently fetched by the DMA channel, during an on-going transfer. When the transfer is completed, the register is automatically reset to 0. The DMA channel uses this register to form the source/destination address of the next DMA cycle, considering also AINC/BINC and BW.	0x0

Table 729: DMA5_A_STARTL_REG (0x50003550)

Bit	Mode	Symbol	Description	Reset
15:0	R/W	DMA5_A_STARTL	Source start address, lower 16 bits	0x0

Table 730: DMA5_A_STARTH_REG (0x50003552)

Bit	Mode	Symbol	Description	Reset
15:0	R/W	DMA5_A_STARTH	Source start address, upper 16 bits	0x0

Table 731: DMA5_B_STARTL_REG (0x50003554)

Bit	Mode	Symbol	Description	Reset
15:0	R/W	DMA5_B_STARTL	Destination start address, lower 16 bits	0x0

Table 732: DMA5_B_STARTH_REG (0x50003556)

Bit	Mode	Symbol	Description	Reset
15:0	R/W	DMA5_B_STARTH	Destination start address, upper 16 bits	0x0

Table 733: DMA5_INT_REG (0x50003558)

Bit	Mode	Symbol	Description	Reset
15:0	R/W	DMA5_INT	Number of transfers until an interrupt is generated. The interrupt is generated after a transfer, if DMA5_INT_REG is equal to DMAx_IDX_REG and before DMAx_IDX_REG is incremented. The bit-field IRQ_ENABLE of DMAx_CTRL_REG must be set to '1' to let the controller generate the interrupt.	0x0

Table 734: DMA5_LEN_REG (0x5000355A)

Bit	Mode	Symbol	Description	Reset
15:0	R/W	DMA5_LEN	DMA channel's transfer length. DMAx_LEN of value 0, 1, 2, ... results into an actual transfer length of 1, 2, 3, ...	0x0

Table 735: DMA5_CTRL_REG (0x5000355C)

Bit	Mode	Symbol	Description	Reset
15:13	-	-	Reserved	0x0
12	R/W	DMA_INIT	0 = DMA performs copy A1 to B1, A2 to B2, etc ... 1 = DMA performs copy of A1 to B1, B2, etc ... This feature is useful for memory initialization to any value. Thus, BINC must be set to '1', while AINC is don't care, as only one fetch from A is done. This process cannot be interrupted by other DMA channels. It is also noted that DMA_INIT should not be used when DREQ_MODE='1'.	0x0
11	R/W	DMA_IDLE	0 = Blocking mode, the DMA performs a fast back-to-back copy, disabling bus access for any bus master with lower priority. 1 = Interrupting mode, the DMA inserts a wait cycle after each store allowing the CPU to steal cycles or cache to perform a burst read. If DREQ_MODE='1', DMA_IDLE is don't care.	0x0
10:8	R/W	DMA_PRIO	The priority level determines which DMA channel will be granted access for transferring data, in case more than one channels are active and request the bus at the same time. The greater the value, the higher the priority. In specific: 000 = lowest priority 111 = highest priority If different channels with equal priority level values request the bus at the same time, an inherent priority mechanism is applied. According to this mechanism, if, for example, both the DMA0 and DMA1 channels have the same priority level, then DMA0 will first be granted access to the bus.	0x0
7	R/W	CIRCULAR	0 = Normal mode. The DMA channel stops after having completed the transfer of length determined by DMAx_LEN_REG. DMA_ON automatically deasserts when the transfer is completed. 1 = Circular mode (applicable only if DREQ_MODE = '1'). In this mode, DMA_ON never deasserts, as the DMA channel automatically resets DMAx_IDX_REG and starts a new transfer.	0x0
6	R/W	AINC	Enable increment of source address. 0 = do not increment (source address stays the same during the transfer) 1 = increment according to the value of BW bit-field (by 1, when BW="00"; by 2, when BW="01"; by 4, when BW="10")	0x0

Table 735: DMA5_CTRL_REG (0x5000355C)

Bit	Mode	Symbol	Description	Reset
5	R/W	BINC	Enable increment of destination address. 0 = do not increment (destination address stays the same during the transfer) 1 = increment according to the value of BW bit-field (by 1, when BW="00" ; by 2, when BW="01" ; by 4, when BW="10")	0x0
4	R/W	DREQ_MODE	0 = DMA channel starts immediately 1 = DMA channel must be triggered by peripheral DMA request (see also the description of DMA_REQ_MUX_REG)	0x0
3	R/W	IRQ_ENABLE	0 = disables interrupts on this channel 1 = enables interrupts on this channel	0x0
2:1	R/W	BW	Bus transfer width: 00 = 1 Byte (suggested for peripherals like UART and 8-bit SPI) 01 = 2 Bytes (suggested for peripherals like I2C and 16-bit SPI) 10 = 4 Bytes (suggested for Memory-to-Memory transfers) 11 = Reserved	0x0
0	R/W	DMA_ON	0 = DMA channel is off, clocks are disabled 1 = DMA channel is enabled. This bit will be automatically cleared after the completion of a transfer, if circular mode is not enabled. In circular mode, this bit stays set.	0x0

Table 736: DMA5_IDX_REG (0x5000355E)

Bit	Mode	Symbol	Description	Reset
15:0	R	DMA5_IDX	This (read-only) register determines the data items currently fetched by the DMA channel, during an on-going transfer. When the transfer is completed, the register is automatically reset to 0. The DMA channel uses this register to form the source/destination address of the next DMA cycle, considering also AINC/BINC and BW.	0x0

Table 737: DMA6_A_STARTL_REG (0x50003560)

Bit	Mode	Symbol	Description	Reset
15:0	R/W	DMA6_A_STARTL	Source start address, lower 16 bits	0x0

Table 738: DMA6_A_STARTH_REG (0x50003562)

Bit	Mode	Symbol	Description	Reset
15:0	R/W	DMA6_A_STARTH	Source start address, upper 16 bits	0x0

Table 739: DMA6_B_STARTL_REG (0x50003564)

Bit	Mode	Symbol	Description	Reset
15:0	R/W	DMA6_B_STARTL	Destination start address, lower 16 bits	0x0

Table 740: DMA6_B_STARTH_REG (0x50003566)

Bit	Mode	Symbol	Description	Reset
15:0	R/W	DMA6_B_STARTH	Destination start address, upper 16 bits	0x0

Table 741: DMA6_INT_REG (0x50003568)

Bit	Mode	Symbol	Description	Reset
15:0	R/W	DMA6_INT	Number of transfers until an interrupt is generated. The interrupt is generated after a transfer, if DMA6_INT_REG is equal to DMA6_IDX_REG and before DMA6_IDX_REG is incremented. The bit-field IRQ_ENABLE of DMA6_CTRL_REG must be set to '1' to let the controller generate the interrupt.	0x0

Table 742: DMA6_LEN_REG (0x5000356A)

Bit	Mode	Symbol	Description	Reset
15:0	R/W	DMA6_LEN	DMA channel's transfer length. DMA6_LEN of value 0, 1, 2, ... results into an actual transfer length of 1, 2, 3, ...	0x0

Table 743: DMA6_CTRL_REG (0x5000356C)

Bit	Mode	Symbol	Description	Reset
15:13	-	-	Reserved	0x0
12	R/W	DMA_INIT	0 = DMA performs copy A1 to B1, A2 to B2, etc ... 1 = DMA performs copy of A1 to B1, B2, etc ... This feature is useful for memory initialization to any value. Thus, BINC must be set to '1', while AINC is don't care, as only one fetch from A is done. This process cannot be interrupted by other DMA channels. It is also noted that DMA_INIT should not be used when DREQ_MODE='1'.	0x0
11	R/W	DMA_IDLE	0 = Blocking mode, the DMA performs a fast back-to-back copy, disabling bus access for any bus master with lower priority. 1 = Interrupting mode, the DMA inserts a wait cycle after each store allowing the CPU to steal cycles or cache to perform a burst read. If DREQ_MODE='1', DMA_IDLE is don't care.	0x0
10:8	R/W	DMA_Prio	The priority level determines which DMA channel will be granted access for transferring data, in case more than one channels are active and request the bus at the same time. The greater the value, the higher the priority. In specific: 000 = lowest priority 111 = highest priority If different channels with equal priority level values request the bus at the same time, an inherent priority mechanism is applied. According to this mechanism, if, for example, both the DMA0 and DMA1 channels have the same priority level, then DMA0 will first be granted access to the bus.	0x0
7	R/W	CIRCULAR	0 = Normal mode. The DMA channel stops after having completed the transfer of length determined by DMA6_LEN_REG. DMA_ON automatically deasserts when the transfer is completed. 1 = Circular mode (applicable only if DREQ_MODE = '1'). In this mode, DMA_ON never deasserts, as the DMA channel automatically resets DMA6_IDX_REG and starts a new transfer.	0x0
6	R/W	AINC	Enable increment of source address. 0 = do not increment (source address stays the same during the transfer) 1 = increment according to the value of BW bit-field (by 1, when BW="00"; by 2, when BW="01"; by 4, when BW="10")	0x0

Table 743: DMA6_CTRL_REG (0x5000356C)

Bit	Mode	Symbol	Description	Reset
5	R/W	BINC	Enable increment of destination address. 0 = do not increment (destination address stays the same during the transfer) 1 = increment according to the value of BW bit-field (by 1, when BW="00" ; by 2, when BW="01" ; by 4, when BW="10")	0x0
4	R/W	DREQ_MODE	0 = DMA channel starts immediately 1 = DMA channel must be triggered by peripheral DMA request (see also the description of DMA_REQ_MUX_REG)	0x0
3	R/W	IRQ_ENABLE	0 = disables interrupts on this channel 1 = enables interrupts on this channel	0x0
2:1	R/W	BW	Bus transfer width: 00 = 1 Byte (suggested for peripherals like UART and 8-bit SPI) 01 = 2 Bytes (suggested for peripherals like I2C and 16-bit SPI) 10 = 4 Bytes (suggested for Memory-to-Memory transfers) 11 = Reserved	0x0
0	R/W	DMA_ON	0 = DMA channel is off, clocks are disabled 1 = DMA channel is enabled. This bit will be automatically cleared after the completion of a transfer, if circular mode is not enabled. In circular mode, this bit stays set.	0x0

Table 744: DMA6_IDX_REG (0x5000356E)

Bit	Mode	Symbol	Description	Reset
15:0	R	DMA6_IDX	This (read-only) register determines the data items currently fetched by the DMA channel, during an on-going transfer. When the transfer is completed, the register is automatically reset to 0. The DMA channel uses this register to form the source/destination address of the next DMA cycle, considering also AINC/BINC and BW.	0x0

Table 745: DMA7_A_STARTL_REG (0x50003570)

Bit	Mode	Symbol	Description	Reset
15:0	R/W	DMA7_A_STARTL	Source start address, lower 16 bits	0x0

Table 746: DMA7_A_STARTH_REG (0x50003572)

Bit	Mode	Symbol	Description	Reset
15:0	R/W	DMA7_A_STARTH	Source start address, upper 16 bits	0x0

Table 747: DMA7_B_STARTL_REG (0x50003574)

Bit	Mode	Symbol	Description	Reset
15:0	R/W	DMA7_B_STARTL	Destination start address, lower 16 bits	0x0

Table 748: DMA7_B_STARTH_REG (0x50003576)

Bit	Mode	Symbol	Description	Reset
15:0	R/W	DMA7_B_STARTH	Destination start address, upper 16 bits	0x0

Table 749: DMA7_INT_REG (0x50003578)

Bit	Mode	Symbol	Description	Reset
15:0	R/W	DMA7_INT	Number of transfers until an interrupt is generated. The interrupt is generated after a transfer, if DMA7_INT_REG is equal to DMAx_IDX_REG and before DMAx_IDX_REG is incremented. The bit-field IRQ_ENABLE of DMAx_CTRL_REG must be set to '1' to let the controller generate the interrupt.	0x0

Table 750: DMA7_LEN_REG (0x5000357A)

Bit	Mode	Symbol	Description	Reset
15:0	R/W	DMA7_LEN	DMA channel's transfer length. DMAx_LEN of value 0, 1, 2, ... results into an actual transfer length of 1, 2, 3, ...	0x0

Table 751: DMA7_CTRL_REG (0x5000357C)

Bit	Mode	Symbol	Description	Reset
15:13	-	-	Reserved	0x0
12	R/W	DMA_INIT	0 = DMA performs copy A1 to B1, A2 to B2, etc ... 1 = DMA performs copy of A1 to B1, B2, etc ... This feature is useful for memory initialization to any value. Thus, BINC must be set to '1', while AINC is don't care, as only one fetch from A is done. This process cannot be interrupted by other DMA channels. It is also noted that DMA_INIT should not be used when DREQ_MODE='1'.	0x0
11	R/W	DMA_IDLE	0 = Blocking mode, the DMA performs a fast back-to-back copy, disabling bus access for any bus master with lower priority. 1 = Interrupting mode, the DMA inserts a wait cycle after each store allowing the CPU to steal cycles or cache to perform a burst read. If DREQ_MODE='1', DMA_IDLE is don't care.	0x0
10:8	R/W	DMA_PRIO	The priority level determines which DMA channel will be granted access for transferring data, in case more than one channels are active and request the bus at the same time. The greater the value, the higher the priority. In specific: 000 = lowest priority 111 = highest priority If different channels with equal priority level values request the bus at the same time, an inherent priority mechanism is applied. According to this mechanism, if, for example, both the DMA0 and DMA1 channels have the same priority level, then DMA0 will first be granted access to the bus.	0x0
7	R/W	CIRCULAR	0 = Normal mode. The DMA channel stops after having completed the transfer of length determined by DMAx_LEN_REG. DMA_ON automatically deasserts when the transfer is completed. 1 = Circular mode (applicable only if DREQ_MODE = '1'). In this mode, DMA_ON never deasserts, as the DMA channel automatically resets DMAx_IDX_REG and starts a new transfer.	0x0
6	R/W	AINC	Enable increment of source address. 0 = do not increment (source address stays the same during the transfer) 1 = increment according to the value of BW bit-field (by 1, when BW="00"; by 2, when BW="01"; by 4, when BW="10")	0x0

Table 751: DMA7_CTRL_REG (0x5000357C)

Bit	Mode	Symbol	Description	Reset
5	R/W	BINC	Enable increment of destination address. 0 = do not increment (destination address stays the same during the transfer) 1 = increment according to the value of BW bit-field (by 1, when BW="00" ; by 2, when BW="01" ; by 4, when BW="10")	0x0
4	R/W	DREQ_MODE	0 = DMA channel starts immediately 1 = DMA channel must be triggered by peripheral DMA request (see also the description of DMA_REQ_MUX_REG)	0x0
3	R/W	IRQ_ENABLE	0 = disables interrupts on this channel 1 = enables interrupts on this channel	0x0
2:1	R/W	BW	Bus transfer width: 00 = 1 Byte (suggested for peripherals like UART and 8-bit SPI) 01 = 2 Bytes (suggested for peripherals like I2C and 16-bit SPI) 10 = 4 Bytes (suggested for Memory-to-Memory transfers) 11 = Reserved	0x0
0	R/W	DMA_ON	0 = DMA channel is off, clocks are disabled 1 = DMA channel is enabled. This bit will be automatically cleared after the completion of a transfer, if circular mode is not enabled. In circular mode, this bit stays set.	0x0

Table 752: DMA7_IDX_REG (0x5000357E)

Bit	Mode	Symbol	Description	Reset
15:0	R	DMA7_IDX	This (read-only) register determines the data items currently fetched by the DMA channel, during an on-going transfer. When the transfer is completed, the register is automatically reset to 0. The DMA channel uses this register to form the source/destination address of the next DMA cycle, considering also AINC/BINC and BW.	0x0

Table 753: DMA_REQ_MUX_REG (0x50003580)

Bit	Mode	Symbol	Description	Reset
15:12	R/W	DMA67_SEL	Select which combination of peripherals are mapped on the DMA channels. The peripherals are mapped as pairs on two channels. Here, the first DMA request is mapped on channel 6 and the second on channel 7. See DMA01_SEL for the peripherals' mapping.	0x0
11:8	R/W	DMA45_SEL	Select which combination of peripherals are mapped on the DMA channels. The peripherals are mapped as pairs on two channels. Here, the first DMA request is mapped on channel 4 and the second on channel 5. See DMA01_SEL for the peripherals' mapping.	0x0
7:4	R/W	DMA23_SEL	Select which combination of peripherals are mapped on the DMA channels. The peripherals are mapped as pairs on two channels. Here, the first DMA request is mapped on channel 2 and the second on channel 3. See DMA01_SEL for the peripherals' mapping.	0x0

Table 753: DMA_REQ_MUX_REG (0x50003580)

Bit	Mode	Symbol	Description	Reset
3:0	R/W	DMA01_SEL	<p>Select which combination of peripherals are mapped on the DMA channels. The peripherals are mapped as pairs on two channels.</p> <p>Here, the first DMA request is mapped on channel 0 and the second on channel 1.</p> <p>0x0: SPI_rx / SPI_tx 0x1: SPI2_rx / SPI2_tx 0x2: UART_rx / UART_tx 0x3: UART2_rx / UART2_tx 0x4: I2C_rx / I2C_tx 0x5: I2C2_rx / I2C2_tx 0x6: USB_rx / USB_tx 0x7: Reserved 0x8: PCM_rx / PCM_tx 0x9: SRC_rx / SRC_tx (for all the supported conversions) 0xA: Reserved 0xB: Reserved 0xC: ADC / - 0xD: Reserved 0xE: Reserved 0xF: Reserved</p> <p>Note: If any of the four available peripheral selector fields (DMA01_SEL, DMA23_SEL, DMA45_SEL, DMA67_SEL) have the same value, the lesser significant selector has higher priority and will control the dma acknowledge. Hence, if DMA01_SEL = DMA23_SEL, the channels 0 and 1 will generate the DMA acknowledge signals for the selected peripheral. Consequently, it is suggested to assign the intended peripheral value to a unique selector field.</p>	0x0

Table 754: DMA_INT_STATUS_REG (0x50003582)

Bit	Mode	Symbol	Description	Reset
15:8	-	-	Reserved	0x0
7	R	DMA_IRQ_CH7	0 = IRQ on channel 7 is not set 1 = IRQ on channel 7 is set	0x0
6	R	DMA_IRQ_CH6	0 = IRQ on channel 6 is not set 1 = IRQ on channel 6 is set	0x0
5	R	DMA_IRQ_CH5	0 = IRQ on channel 5 is not set 1 = IRQ on channel 5 is set	0x0
4	R	DMA_IRQ_CH4	0 = IRQ on channel 4 is not set 1 = IRQ on channel 4 is set	0x0
3	R	DMA_IRQ_CH3	0 = IRQ on channel 3 is not set 1 = IRQ on channel 3 is set	0x0
2	R	DMA_IRQ_CH2	0 = IRQ on channel 2 is not set 1 = IRQ on channel 2 is set	0x0
1	R	DMA_IRQ_CH1	0 = IRQ on channel 1 is not set 1 = IRQ on channel 1 is set	0x0
0	R	DMA_IRQ_CH0	0 = IRQ on channel 0 is not set 1 = IRQ on channel 0 is set	0x0

Table 755: DMA_CLEAR_INT_REG (0x50003584)

Bit	Mode	Symbol	Description	Reset
15:8	-	-	Reserved	0x0
7	R0/W	DMA_RST_IRQ_CH7	Writing a 1 will reset the IRQ of channel 7 ; writing a 0 will have no effect.	0x0
6	R0/W	DMA_RST_IRQ_CH6	Writing a 1 will reset the IRQ of channel 6 ; writing a 0 will have no effect.	0x0
5	R0/W	DMA_RST_IRQ_CH5	Writing a 1 will reset the IRQ of channel 5 ; writing a 0 will have no effect.	0x0
4	R0/W	DMA_RST_IRQ_CH4	Writing a 1 will reset the IRQ of channel 4 ; writing a 0 will have no effect.	0x0
3	R0/W	DMA_RST_IRQ_CH3	Writing a 1 will reset the IRQ of channel 3 ; writing a 0 will have no effect.	0x0
2	R0/W	DMA_RST_IRQ_CH2	Writing a 1 will reset the IRQ of channel 2 ; writing a 0 will have no effect.	0x0
1	R0/W	DMA_RST_IRQ_CH1	Writing a 1 will reset the IRQ of channel 1 ; writing a 0 will have no effect.	0x0
0	R0/W	DMA_RST_IRQ_CH0	Writing a 1 will reset the IRQ of channel 0 ; writing a 0 will have no effect.	0x0

37.27 APU REGISTER FILE

Table 756: Register map APU

Address	Port	Description
0x50004000	SRC1_CTRL_REG	SRC1 control register
0x50004004	SRC1_IN_FS_REG	SRC1 Sample input rate
0x50004008	SRC1_OUT_FS_REG	SRC1 Sample output rate
0x5000400C	SRC1_IN1_REG	SRC1 data in 1
0x50004010	SRC1_IN2_REG	SRC1 data in 2
0x50004014	SRC1_OUT1_REG	SRC1 data out 1
0x50004018	SRC1_OUT2_REG	SRC1 data out 2
0x5000401C	APU_MUX_REG	APU mux register
0x50004020	COEF10_SET1_REG	SRC coefficient 1,0 set 1
0x50004024	COEF32_SET1_REG	SRC coefficient 3,2 set 1
0x50004028	COEF54_SET1_REG	SRC coefficient 5,4 set 1
0x5000402C	COEF76_SET1_REG	SRC coefficient 7,6 set 1
0x50004030	COEF98_SET1_REG	SRC coefficient 9,8 set 1
0x50004034	COEF0A_SET1_REG	SRC coefficient 10 set 1
0x50004100	PCM1_CTRL_REG	PCM1 Control register
0x50004104	PCM1_IN1_REG	PCM1 data in 1
0x50004108	PCM1_IN2_REG	PCM1 data in 2
0x5000410C	PCM1_OUT1_REG	PCM1 data out 1
0x50004110	PCM1_OUT2_REG	PCM1 data out 2

Table 757: SRC1_CTRL_REG (0x50004000)

Bit	Mode	Symbol	Description	Reset
31:30	-	-	Reserved	0
29:28	R/W	SRC_PDM_MODE	PDM Output mode selection on PDM_DO1 00: No output 01: Right channel (falling edge of PDM_CLK) 10: Left channel (rising edge of PDM_CLK) 11: Left and Right channel	0
27:26	-	-	Reserved	0
25	W	SRC_OUT_FLOWCLR	Writing a 1 clears the SRC1_OUT Overflow/underflow bits 23-22. No more over/underflow indications while bit is 1. Keep 1 until the over/under flow bit is cleared	0
24	W	SRC_IN_FLOWCLR	Writing a 1 clears the SRC1_IN Overflow/underflow bits 21-20. No more over/underflow indications while bit is 1. Keep 1 until the over/under flow bit is cleared	0
23	R	SRC_OUT_UNFLOW	1 = SRC1_OUT Underflow occurred	0
22	R	SRC_OUT_OVFLOW	1 = SRC1_OUT Overflow occurred	0
21	R	SRC_IN_UNFLOW	1 = SRC1_IN Underflow occurred	0
20	R	SRC_IN_OVFLOW	1 = SRC1_IN Overflow occurred	0
19	-	-	Reserved	0
18	R	SRC_OUT_OK	SRC1_OUT Status 0: acquisition in progress 1: acquisition ready (In manual mode this bit is always 1)	0

Table 757: SRC1_CTRL_REG (0x50004000)

Bit	Mode	Symbol	Description	Reset
17:16	R/W	SRC_OUT_US	SRC1_OUT UpSampling IIR filters setting 00: for sample rates up-to 48kHz 01: for sample rates of 96kHz 10: reserved 11: for sample rates of 192kHz	0
15	-	-	Reserved	0
14	R/W	SRC_OUT_CAL_BY PASS	SRC1_OUT1 upsampling filter bypass 0:Do not bypass 1:Bypass filter	0
13	R/W	SRC_OUT_AMODE	SRC1_OUT1 Automatic Conversion mode 0:Manual mode 1:Automatic mode	0
12:10	-	-	Reserved	0
9:8	-	-	Reserved	0
7	R/W	SRC_DITHER_DISA BLE	Dithering feature 0: Enable 1: Disable	0
6	R	SRC_IN_OK	SRC1_IN status 0: Acquisition in progress 1: Acquisition ready	0
5:4	R/W	SRC_IN_DS	SRC1_IN UpSampling IIR filters setting 00: for sample rates up-to 48kHz 01: for sample rates of 96kHz 10: reserved 11: for sample rates of 192kHz	0
3	-	-	Reserved	0
2	R/W	SRC_IN_CAL_BYPA SS	SRC1_IN upsampling filter bypass 0: Do not bypass 1: Bypass filter	0
1	R/W	SRC_IN_AMODE	SRC1_IN Automatic conversion mode 0: Manual mode 1: Automatic mode	0
0	R/W	SRC_EN	SRC1_IN and SRC1_OUT enable 0: disabled 1: enabled	0

Table 758: SRC1_IN_FS_REG (0x50004004)

Bit	Mode	Symbol	Description	Reset
31:24	-	-	Reserved	0

Table 758: SRC1_IN_FS_REG (0x50004004)

Bit	Mode	Symbol	Description	Reset																																								
23:0	R/W	SRC_IN_FS	<p>SRC_IN Sample rate $SRC_IN_FS = 8192 * Sample_rate / 100$ Sample_rate upper limit is 192 kHz. For 96 kHz and 192 kHz SRC_CTRLx_REG[SRC_IN_DS] must be set as shown below:</p> <table border="1"> <thead> <tr> <th>Sample_rate</th> <th>SRC_IN_FS</th> <th>SRC_IN_DS</th> <th>Audio BW</th> </tr> </thead> <tbody> <tr> <td>8000 Hz</td> <td>0xA0000</td> <td>0</td> <td>4000 Hz</td> </tr> <tr> <td>11025 Hz</td> <td>0x0DC800</td> <td>0</td> <td>5512 Hz</td> </tr> <tr> <td>16000 Hz</td> <td>0x140000</td> <td>0</td> <td>8000 Hz</td> </tr> <tr> <td>22050 Hz</td> <td>0x1B9000</td> <td>0</td> <td>11025 Hz</td> </tr> <tr> <td>32000 Hz</td> <td>0x280000</td> <td>0</td> <td>16000 Hz</td> </tr> <tr> <td>44100 Hz</td> <td>0x372000</td> <td>0</td> <td>22050 Hz</td> </tr> <tr> <td>48000 Hz</td> <td>0x3C0000</td> <td>0</td> <td>24000 Hz</td> </tr> <tr> <td>96000 Hz</td> <td>0x3C0000</td> <td>1</td> <td>24000 Hz</td> </tr> <tr> <td>192000 Hz</td> <td>0x3C0000</td> <td>3</td> <td>24000 Hz</td> </tr> </tbody> </table> <p>In manual SRC mode, SRC_IN_FS can be set and adjusted to the desired sample rate at any time. In automatic mode the SRC returns the final sample rate as soon as SRC_IN_OK. Note that SRC_DS is not calculated in automatic mode and must be set manually automatic mode with Sample_rate of 96 kHz and 192 kHz.</p>	Sample_rate	SRC_IN_FS	SRC_IN_DS	Audio BW	8000 Hz	0xA0000	0	4000 Hz	11025 Hz	0x0DC800	0	5512 Hz	16000 Hz	0x140000	0	8000 Hz	22050 Hz	0x1B9000	0	11025 Hz	32000 Hz	0x280000	0	16000 Hz	44100 Hz	0x372000	0	22050 Hz	48000 Hz	0x3C0000	0	24000 Hz	96000 Hz	0x3C0000	1	24000 Hz	192000 Hz	0x3C0000	3	24000 Hz	0
Sample_rate	SRC_IN_FS	SRC_IN_DS	Audio BW																																									
8000 Hz	0xA0000	0	4000 Hz																																									
11025 Hz	0x0DC800	0	5512 Hz																																									
16000 Hz	0x140000	0	8000 Hz																																									
22050 Hz	0x1B9000	0	11025 Hz																																									
32000 Hz	0x280000	0	16000 Hz																																									
44100 Hz	0x372000	0	22050 Hz																																									
48000 Hz	0x3C0000	0	24000 Hz																																									
96000 Hz	0x3C0000	1	24000 Hz																																									
192000 Hz	0x3C0000	3	24000 Hz																																									

Table 759: SRC1_OUT_FS_REG (0x50004008)

Bit	Mode	Symbol	Description	Reset																																								
31:24	-	-	Reserved	0																																								
23:0	R/W	SRC_OUT_FS	<p>SRC_OUT Sample rate $SRC_OUT_FS = 8192 * Sample_rate / 100$ Sample_rate upper limit is 192 kHz. For 96 kHz and 192 kHz SRC_CTRLx_REG[SRC_DS] must be set as shown below:</p> <table border="1"> <thead> <tr> <th>Sample_rate</th> <th>SRC_OUT_FS</th> <th>SRC_OUT_DS</th> <th>Audio BW</th> </tr> </thead> <tbody> <tr> <td>8000 Hz</td> <td>0xA0000</td> <td>0</td> <td>4000 Hz</td> </tr> <tr> <td>11025 Hz</td> <td>0x0DC800</td> <td>0</td> <td>5512 Hz</td> </tr> <tr> <td>16000 Hz</td> <td>0x140000</td> <td>0</td> <td>8000 Hz</td> </tr> <tr> <td>22050 Hz</td> <td>0x1B9000</td> <td>0</td> <td>11025 Hz</td> </tr> <tr> <td>32000 Hz</td> <td>0x280000</td> <td>0</td> <td>16000 Hz</td> </tr> <tr> <td>44100 Hz</td> <td>0x372000</td> <td>0</td> <td>22050 Hz</td> </tr> <tr> <td>48000 Hz</td> <td>0x3C0000</td> <td>0</td> <td>24000 Hz</td> </tr> <tr> <td>96000 Hz</td> <td>0x3C0000</td> <td>1</td> <td>24000 Hz</td> </tr> <tr> <td>192000 Hz</td> <td>0x3C0000</td> <td>3</td> <td>24000 Hz</td> </tr> </tbody> </table> <p>In manual SRC mode, SRC_OUT_FS can be set and adjusted to the desired sample rate at any time. In automatic mode the SRC returns the final sample rate as soon as SRC_OUT_OK. Note that SRC_DS is not calculated in automatic mode and must be set manually automatic mode with Sample_rate of 96 kHz and 192 kHz.</p>	Sample_rate	SRC_OUT_FS	SRC_OUT_DS	Audio BW	8000 Hz	0xA0000	0	4000 Hz	11025 Hz	0x0DC800	0	5512 Hz	16000 Hz	0x140000	0	8000 Hz	22050 Hz	0x1B9000	0	11025 Hz	32000 Hz	0x280000	0	16000 Hz	44100 Hz	0x372000	0	22050 Hz	48000 Hz	0x3C0000	0	24000 Hz	96000 Hz	0x3C0000	1	24000 Hz	192000 Hz	0x3C0000	3	24000 Hz	0
Sample_rate	SRC_OUT_FS	SRC_OUT_DS	Audio BW																																									
8000 Hz	0xA0000	0	4000 Hz																																									
11025 Hz	0x0DC800	0	5512 Hz																																									
16000 Hz	0x140000	0	8000 Hz																																									
22050 Hz	0x1B9000	0	11025 Hz																																									
32000 Hz	0x280000	0	16000 Hz																																									
44100 Hz	0x372000	0	22050 Hz																																									
48000 Hz	0x3C0000	0	24000 Hz																																									
96000 Hz	0x3C0000	1	24000 Hz																																									
192000 Hz	0x3C0000	3	24000 Hz																																									

Table 760: SRC1_IN1_REG (0x5000400C)

Bit	Mode	Symbol	Description	Reset
31:8	R/W	SRC_IN	SRC1_IN1	0

Table 761: SRC1_IN2_REG (0x50004010)

Bit	Mode	Symbol	Description	Reset
31:8	R/W	SRC_IN	SRC1_IN2	0

Table 762: SRC1_OUT1_REG (0x50004014)

Bit	Mode	Symbol	Description	Reset
31:8	R	SRC_OUT	SRC1_OUT1	0

Table 763: SRC1_OUT2_REG (0x50004018)

Bit	Mode	Symbol	Description	Reset
31:8	R	SRC_OUT	SRC1_OUT2	0

Table 764: APU_MUX_REG (0x5000401C)

Bit	Mode	Symbol	Description	Reset
6	R/W	PDM1_MUX_IN	PDM1 input mux 0 = SRC1_MUX_IN 1 = PDM input	0x0
5:3	R/W	PCM1_MUX_IN	PCM1 input mux 0 = off 1 = SRC1 output 2 = PCM output registers	0x0
2:0	R/W	SRC1_MUX_IN	SRC1 input mux 0 = off 1 = PCM output 2 = SRC1 input registers	0x0

Table 765: COEF10_SET1_REG (0x50004020)

Bit	Mode	Symbol	Description	Reset
31:16	R/W	SRC_COEF1	coefficient 1	0x79A9
15:0	R/W	SRC_COEF0	coefficient 0	0x9278

Table 766: COEF32_SET1_REG (0x50004024)

Bit	Mode	Symbol	Description	Reset
31:16	R/W	SRC_COEF3	coefficient 3	0x6D56
15:0	R/W	SRC_COEF2	coefficient 2	0x8B41

Table 767: COEF54_SET1_REG (0x50004028)

Bit	Mode	Symbol	Description	Reset
31:16	R/W	SRC_COEF5	coefficient 5	0x9BC5
15:0	R/W	SRC_COEF4	coefficient 4	0xBE15

Table 768: COEF76_SET1_REG (0x5000402C)

Bit	Mode	Symbol	Description	Reset
31:16	R/W	SRC_COEF7	coefficient 7	0x8C28
15:0	R/W	SRC_COEF6	coefficient 6	0x7E1A

Table 769: COEF98_SET1_REG (0x50004030)

Bit	Mode	Symbol	Description	Reset
31:16	R/W	SRC_COEF9	coefficient 9	0x92D7
15:0	R/W	SRC_COEF8	coefficient 8	0x75E6

Table 770: COEF0A_SET1_REG (0x50004034)

Bit	Mode	Symbol	Description	Reset
15:0	R/W	SRC_COEF10	coefficient 10	0x41F2

Table 771: PCM1_CTRL_REG (0x50004100)

Bit	Mode	Symbol	Description	Reset
31:20	R/W	PCM_FSC_DIV	PCM Framesync divider, Values 7-0xFFFF. To divide by N, write N-1. (Minimum value N-1=7 for 8 bits PCM_FSC) Note if PCM_CLK_BIT=1, N must always be even	0x0
19:17	-	-	Reserved	0x0
16	R/W	PCM_FSC_EDGE	0: shift channels 1, 2, 3, 4, 5, 6, 7, 8 after PCM_FSC edge 1: shift channels 1, 2, 3, 4 after PCM_FSC edge shift channels 5, 6, 7, 8 after opposite PCM_FSC edge	0x0
15:11	R/W	PCM_CH_DEL	Channel delay in multiples of 8 bits	0x0
10	R/W	PCM_CLK_BIT	0:One clock cycle per data bit 1:Two cloc cycles per data bit	0x0
9	R/W	PCM_FSCINV	0: PCM FSC 1: PCM FSC inverted	0x0
8	R/W	PCM_CLKINV	0:PCM CLK 1:PCM CLK inverted	0x0
7	R/W	PCM_PPOD	0:PCM DO push pull 1:PCM DO open drain	0x0
6	R/W	PCM_FSCDEL	0:PCM FSC starts one cycle before MSB bit 1:PCM FSC starts at the same time as MSB bit	0x0
5:2	R/W	PCM_FSCLLEN	0:PCM FSC length equal to 1 data bit N:PCM FSC length equal to N*8	0x0
1	R/W	PCM_MASTER	0:PCM interface in slave mode 1:PCM interface in master mode	0x0
0	R/W	PCM_EN	0:PCM interface disabled 1:PCM interface enabled	0x0

Table 772: PCM1_IN1_REG (0x50004104)

Bit	Mode	Symbol	Description	Reset
31:0	R	PCM_IN	PCM1_IN1 bits 31-0	0xFFFFFFFF FFF

Table 773: PCM1_IN2_REG (0x50004108)

Bit	Mode	Symbol	Description	Reset
31:0	R	PCM_IN	PCM1_IN2 bits 31-0	0xFFFFFFFF FFF

Table 774: PCM1_OUT1_REG (0x5000410C)

Bit	Mode	Symbol	Description	Reset
31:0	R/W	PCM_OUT	PCM1_OUT1 bits 31-0	0xFFFFFFFF FFF

Table 775: PCM1_OUT2_REG (0x50004110)

Bit	Mode	Symbol	Description	Reset
31:0	R/W	PCM_OUT	PCM1_OUT2 bits 31-0	0xFFFFFFFF FFF

37.28 TRNG REGISTER FILE

Table 776: Register map TRNG

Address	Port	Description
0x50005000	TRNG_CTRL_REG	TRNG control register
0x50005004	TRNG_FIFOLVL_REG	TRNG FIFO level register
0x50005008	TRNG_VER_REG	TRNG Version register

Table 777: TRNG_CTRL_REG (0x50005000)

Bit	Mode	Symbol	Description	Reset
31:2	-	-	Reserved	0x0
1	R/W	TRNG_MODE	0: select the TRNG with asynchronous free running oscillators (default) 1: select the pseudo-random generator with synchronous oscillators (for simulation purpose only)	0x0
0	R/W	TRNG_ENABLE	0: Disable the TRNG 1: Enable the TRNG this signal is ignored when the FIFO is full	0x0

Table 778: TRNG_FIFOLVL_REG (0x50005004)

Bit	Mode	Symbol	Description	Reset
31:6	-	-	Reserved	0x0
5	R	TRNG_FIFOFULL	1:FIFO full indication. This bit is cleared if the FIFO is read.	0x0
4:0	R	TRNG_FIFOLVL	Number of 32 bit words of random data in the FIFO (max 31) until the FIFO is full. When it is 0 and TRNG_FIFOFULL is 1, it means the FIFO is full.	0x0

Table 779: TRNG_VER_REG (0x50005008)

Bit	Mode	Symbol	Description	Reset
31:24	R	TRNG_MAJ	Major version number	0x0
23:16	R	TRNG_MIN	Minor version number	0x0
15:0	R	TRNG_SVN	SVN revision number	0x103

37.29 ELLIPTIC CURVE CONTROLLER REGISTER FILE

Table 780: Register map Elliptic Curve Controller

Address	Port	Description
0x50006000	ECC_CONFIG_REG	Configuration register
0x50006004	ECC_COMMAND_REG	Command register
0x50006008	ECC_CONTROL_REG	Control register
0x5000600C	ECC_STATUS_REG	Status register
0x50006010	ECC_VERSION_REG	Version register

Table 781: ECC_CONFIG_REG (0x50006000)

Bit	Mode	Symbol	Description	Reset
20:16	R/W	ECC_OPPTRC	When executing primitive arithmetic operations, this pointer defines the location where the result will be stored in Memory.	0x0
15:13	-	-	Reserved	0x0
12:8	R/W	ECC_OPPTRB	When executing primitive arithmetic operations, this Pointer defines where operand B is located in memory.	0x0
7:5	-	-	Reserved	0x0
4:0	R/W	ECC_OPPTRA	When executing primitive arithmetic operations, this Pointer defines where operand A is located in memory.	0x0

Table 782: ECC_COMMAND_REG (0x50006004)

Bit	Mode	Symbol	Description	Reset
31	R/W	ECC_CALC_R2	This bit indicates if the IP has to calculate $R \bmod N$ for the next operation. This bit must be set to 1 when a new prime number has been programmed. This bit is automatically cleared when $R \bmod N$ has been calculated. '0': no effect '1': forces the IP to re-calculate $R \bmod N$	0x0
30	R/W	ECC_SIGNB	Sign of parameter B in equation $y^2=x^3+Ax+B$ '0': B is positive '1': B is negative	0x0
29	R/W	ECC_SIGNA	Sign of parameter A in equation $y^2=x^3+Ax+B$ '0': A is positive '1': A is negative	0x0
28:16	-	-	Reserved	0x0
15:8	R/W	ECC_SIZEOFOPERANDS	This field defines the size (= number of 64-bit double words) of the operands for the current operation. Possible values are limited by the generic parameter <code>g_Log2MaxDataSize</code> that defines the max space allocated or reserved to each operand. Arbitrary Data/Key size from 128 up to 2566 are supported: 0x02 (02d) -> 128-bit Data/Key size 0x03 (02d) -> 256-bit Data/Key size ECC-ECDSA - Prime Field F(p) 0x03 -> 192-bit (Curve P-192) 0x04 -> 256-bit (Curves P-224 & P-256) ECC-ECDSA - Binary Field F(2m) 0x03 -> 192-bit (Curve K-163) 0x04 -> 256-bit (Curve K-233) - 4 Xers: 0x01, 0x02, 0x4, 0x6 -> 64, 128 & multiples of 128 bits	0x0

Table 782: ECC_COMMAND_REG (0x50006004)

Bit	Mode	Symbol	Description	Reset
7	R/W	ECC_FIELD	'0': Field is F(p) '1': Field is F(2m)	0x0
6:0	R/W	ECC_TYPEOPERATION	<p>Primitive Arithmetic Operations F(p) & F(2m)</p> <p>[6:4] = 0x0 [3:0] = 0x0 -> Reserved 0x1 -> Modular Addition 0x2 -> Modular Subtraction 0x3 -> Modular Multiplication (Odd N) 0x4 -> Modular Reduction (Odd N) 0x5 -> Modular Division (Odd N) 0x6 -> Modular Inversion (Odd N) 0x7 -> Reserved 0x8 -> Multiplication 0x9 -> Modular Inversion (Even N) 0xA -> Modular Reduction (Even N) others -> Reserved C = A + B mod N C = A - B mod N C = A * B mod N C = B mod N C = A/B mod N C = 1/B mod N C = A * B C = 1/B mod N C = B mod N High-level RSA, CRT & DSA Operations - F(p) only ([7] forced to 0) [6:4] = 0x1 [3:0] = 0x0 -> MulModN 0x1 -> MulAddN 0x2 -> ECMQV (part1) others -> Reserved</p> <p>Primitive ECC & Check Point Operations F(p) & F(2m)</p> <p>[6:4] = 0x2 [3:0] = 0x0 -> Point Doubling (Projective Coord.) 0x1 -> ptAdd3 0x2 -> GenSessionKey 0x3 -> Check_AB (ECDSA) 0x4 -> Check_n (ECDSA) 0x5 -> Check single value less than N 0x6 -> Check_Point_On_Curve 0x7 -> Reserved 0x8 -> Curve25519 point multiplication 0x9 -> Ed25519 Check point on curve 0xA -> Ed25519 ScalarMult 0xB -> Ed25519 CheckValid others -> Reserved (continued on next page)</p>	0x0

Table 782: ECC_COMMAND_REG (0x50006004)

Bit	Mode	Symbol	Description	Reset
6:0	R/W	ECC_TYPEOPERATION (continued)	High-level ECC ECDSA Operations F(p) & F(2m) [6:4] = 0x3 [3:0] = 0x0 -> ECMQV (part 2) 0x1 -> Verify ZKP 0x2 -> ECDSA Domain Parameters Validation others -> Reserved [6:4]=0x4, 0x5, 0x6, 0x7 -> Reserved	0x0

Table 783: ECC_CONTROL_REG (0x50006008)

Bit	Mode	Symbol	Description	Reset
0	R/W	ECC_START	The Start signal is activated when all data and key inputs have been loaded in the external crypto memory and are available for processing. This signal is active high and is sampled on the rising edge of Clk. When this signal goes high, the PK Command present in the PK_CommandReg[] is initiated and executed. The PK_Start signal is ignored when the core is already processing data and is automatically cleared when the operation is finished	0x0

Table 784: ECC_STATUS_REG (0x5000600C)

Bit	Mode	Symbol	Description	Reset
16	R	ECC_BUSY	This Status Signal indicates that the core is processing data. This signal is active high and goes low when the selected algorithm is finished.	0x0
15:13	-	-	Reserved	0x0
12	R	ECC_PRIMALITYTESTRESULT	After the Miller-Rabin Primality test, this flag is: - set to 0 when the random number under test is probably prime - cleared to 1 when the random number under test is composite	0x0
11	R	ECC_NOTINVERTIBLE	This flag is set to 1 when executing a modular inversion (PK_CommandReg[3:0] = 0x6 or 0x9) if the operand is not invertible.	0x0
10	R	ECC_PARAM_AB_NOTVALID	Status signal set to 1 when parameters A and B are not valid, i.e. $4A + 27B = 0$. This flag is updated after execution of the command Check_AB.	0x0
9	R	ECC_SIGNATURE_NOTVALID	This flag indicates if the signature can be accepted or must be rejected. This flag is set to 1 when the signature is not valid and is updated after execution of the command ECDSA_Generation, ECDSA_Verification, DSA_Generation, DSA_Verification.	0x0
8	-	-	Reserved	0x0
7	R	ECC_PARAM_n_NOTVALID	Status signal set to 1 when Parameter n is not valid. This flag is updated after execution of the command Check_n.	0x0
6	R	ECC_COUPLE_NOTVALID	Status signal set to 1 when couple x, y is not valid (i.e. not smaller than the prime). This flag is updated after execution of the command Check_Couple_Less_Prime.	0x0

Table 784: ECC_STATUS_REG (0x5000600C)

Bit	Mode	Symbol	Description	Reset
5	R	ECC_POINT_PX_AT_INFINITY	Status signal set to 1 when Point Px is at the infinity. This flag is updated after execution of an ECC operation.	0x0
4	R	ECC_POINT_PX_NOT_ON_CURVE	Status signal set to 1 when Point Px is not on the defined EC. This flag is updated after execution of the command Check_Point_OnCurve.	0x0
3:0	R	ECC_FAIL_ADDRESS	Address of the last Point detected as Not On Curve, Not Valid or at the infinity.	0x0

Table 785: ECC_VERSION_REG (0x50006010)

Bit	Mode	Symbol	Description	Reset
15:8	R	ECC_HVN	Version of IP to be read via CPU interface.	0x4
7:0	R	ECC_SVN	Version of Crypto code to be read via CPU interface. Note that this should be read before ECC is used since it corrupts its contents.	0x0

38 Specifications

All MIN/MAX specification limits are guaranteed by design, production testing and/or statistical characterization, and are valid over the full operating temperature range and power supply range, unless otherwise noted. Typical values are based on characterization results at default measurement conditions and are informative only.

Default measurement conditions (unless otherwise specified): $V_{BAT1} = V_{BAT2} = 3.0\text{ V}$, $T_A = 25\text{ }^{\circ}\text{C}$. All radio measurements are performed with standard RF measurement equipment providing a source/load impedance of $50\ \Omega$.

Table 786: Absolute maximum ratings

Parameter	Description	Conditions	Min	Typ	Max	Unit
V _{PIN_LIM_DEF}	limiting voltage on a pin	default, unless otherwise specified	-0.1		3.6	V
V _{BAT_LIM}	limiting battery supply voltage	pin VBAT	0		6	V
V _{BUS_LIM}	limiting bus supply voltage	pin VBUS	0		6.5	V
t _{R_SUP}	power supply rise time				30	ms
V _{PIN_LIM_3V3}	limiting voltage on a pin	3.3 V I/O pins	0		3.45	V
V _{PIN_LIM_1V8}	limiting voltage on a pin	1.8 V I/O pins	0		1.98	V
V _{ESD_HBM_QFN60}	electrostatic discharge voltage (Human Body Model)	QFN60 package			2000	V
V _{ESD_CDM_QFN60}	electrostatic discharge voltage (Charged Device Model)	QFN60 package			500	V
T _{STG}	storage temperature		-50		150	°C

Table 787: Recommended operating conditions

Parameter	Description	Conditions	Min	Typ	Max	Unit
V _{BAT}	battery supply voltage	pin VBAT1 and VBAT2	1.7		4.75	V
V _{BAT_OTP}	V33 rail supply voltage	Voltage range for OTP programming. Required temperature for programming is between -20°C and 85°C	2.25		3.6	V
V _{BUS}	bus supply voltage	pin VBUS	4.2		5.75	V
V _{PIN_3V3}	voltage on a pin	3.3 V I/O pins	0		3.3	V
V _{PIN_1V8}	voltage on a pin	1.8 V I/O pins	0		1.8	V
T _A	ambient temperature		-40		85	°C

Table 788: DC characteristics

Parameter	Description	Conditions	Min	Typ	Max	Unit
I _{BAT_IDLE}	battery supply current	CPU is idle (Wait for Interrupt - WFI); sys_clk = 16 MHz; pclk = 2 MHz; DC-DC on; FLASH off; peripherals on; V _{BAT} = 3 V.		0.6		mA
I _{BAT_RUN_16MHz}	battery supply current	CPU is executing code from 32 kB RAM; sys_clk = 16 MHz; pclk=2 MHz; DC-DC on; FLASH off; peripherals on; V _{BAT} = 3 V.		1.4		mA

Table 788: DC characteristics

Parameter	Description	Conditions	Min	Typ	Max	Unit
I _{BAT_RUN_48MHz}	battery supply current	CPU is executing code from 32 kB RAM; sys_clk = 48 MHz; pclk = 2 MHz; DC-DC on; FLASH off; PLL on; peripherals on; V _{BAT} = 3 V.		3.9		mA
I _{BAT_RUN_96MHz}	battery supply current	CPU is executing code from 32 kB RAM; sys_clk = 96 MHz; pclk = 2 MHz; DC-DC on; FLASH off; PLL on; peripherals on; V _{BAT} = 3 V.		6.2		mA
I _{BAT_HIBERN}	battery supply current	Hibernation mode; no RAM retained; RCX clock on; VBAT_RET on; DC-DC off; V _{DD_RET} = 0.9 V; FLASH off; V _{BAT} = 3 V.		1.3		μA
I _{BAT_DP_SLP_8K}	battery supply current	Deep Sleep mode; 8 kB RAM retained; RCX clock on; VBAT_RET on; DC-DC off; V _{DD_RET} = 0.9 V; FLASH off; V _{BAT} = 3 V.		1.5		μA
I _{BAT_DP_SLP_24K}	battery supply current	Deep Sleep mode; 24 kB RAM retained; aRCX clock on; VBAT_RET on; DC-DC off; V _{DD_RET} = 0.9 V; FLASH off; V _{BAT} = 3 V.		1.9		μA
I _{BAT_EX_SLP_16K_32K_FP}	battery supply current	Extended Sleep mode; 16 kB (code) and 32 kB (data) RAM retained; XTAL32K on; DC-DC off; V _{DD_RET} = 0.9 V; FLASH in Power Down mode; V _{BAT} = 3 V.		2.6		μA
I _{BAT_EX_SLP_16K_128K_FP}	battery supply current	Extended Sleep mode; 16 kB cache and 128 kB (data) RAM retained; XTAL32K on; DC-DC off; V _{DD_RET} = 0.9 V; FLASH in Power Down mode; V _{BAT} = 3 V.		4.6		μA
I _{BAT_BLE_RX_16M_FS}	battery supply current	BLE receive mode; f _{CLK} = 16 MHz; DC-DC on; FLASH in Standby mode; V _{BAT} = 3 V.		5.8		mA
I _{BAT_BLE_TX_16M_FS}	battery supply current	BLE transmit mode; f _{CLK} = 16 MHz; DC-DC on; FLASH in Standby mode; V _{BAT} = 3 V.		5.9		mA

Table 788: DC characteristics

Parameter	Description	Conditions	Min	Typ	Max	Unit
I _{BAT_BLE_RX_96} M_FS	battery supply current	BLE receive mode; f _{CLK} = 96 MHz; DC-DC on; FLASH in Standby mode; V _{BAT} = 3 V.		8.5		mA
I _{BAT_BLE_TX_96} M_FS	battery supply current	BLE transmit mode; f _{CLK} = 96 MHz; DC-DC on; FLASH in Standby mode; V _{BAT} = 3 V.		8.1		mA

Table 789: Timing characteristics

Parameter	Description	Conditions	Min	Typ	Max	Unit
t _{STA_SUP}	supply startup time	time from power-on reset or wake-up to BootROM/ application execution start			2000	μs
t _{STA_BOOT}	booter startup time	BootROM code execution time			20	ms
t _{CLF_OTP}	cache line fetch time	from OTP; line size = 8 B			6	clock
t _{CLF_FL}	cache line fetch time	from FLASH; line size = 8 B			40	clock

Table 790: Thermal characteristics

Parameter	Description	Conditions	Min	Typ	Max	Unit
R _{TH_J-A_sPCB}	Device thermal resistance junction to ambient	aQFN60 package; Non-standard PCB; Zero number of thermal vias (worst case);			56.9	°C/W
R _{TH_J-A_jPCB}	Device thermal resistance junction to ambient	aQFN60 package; JEDEC standard PCB; Zero number of thermal vias (worst case);			40	°C/W

Table 791: 16 MHz Crystal Oscillator: Recommended operating conditions

Parameter	Description	Conditions	Min	Typ	Max	Unit
f _{X TAL(16M)}	crystal oscillator frequency			16		MHz
ESR(16M)	equivalent series resistance				100	Ω
C _{L(16M)}	load capacitance	No external capacitors are required.	6	10	12	pF
C _{0(16M)}	shunt capacitance	No external capacitors are required.			5	pF
Δf _{X TAL(16M)}	crystal frequency tolerance	After optional trimming; including aging and temperature drift (Note 21)	-20		20	ppm

Table 791: 16 MHz Crystal Oscillator: Recommended operating conditions

Parameter	Description	Conditions	Min	Typ	Max	Unit
$\Delta f_{X_TAL(16M)UNT}$	crystal frequency tolerance	Untrimmed; including aging and temperature drift (Note 22)	-40		40	ppm
$P_{DRV(MAX)(16M)}$	maximum drive power	(Note 23)	100			μW
$V_{CLK(EXT)(16M)}$	external clock voltage	In case of external clock source on XTAL16Mp (XTAL16Mm floating or connected to mid-level 0.6 V)	1	1.2	1.26	V
$\varphi_N(EXTERNAL)16M$	phase noise	$f_C = 50$ kHz; in case of external clock source			-130	dBc/Hz

Note 21: Using the internal varicaps a wide range of crystals can be trimmed to the required tolerance.

Note 22: Maximum allowed frequency tolerance for compensation by the internal varicap trimming mechanism.

Note 23: Select a crystal which can handle a drive level of at least this specification.

Table 792: 16 MHz Crystal Oscillator: Timing characteristics

Parameter	Description	Conditions	Min	Typ	Max	Unit
$t_{STA(XTAL)(16M)}$	crystal oscillator startup time	ESR=25 Ohm; $C_0=3$ pF;	0.5	2	3	ms

Table 793: 32 kHz Crystal Oscillator: Recommended operating conditions

Parameter	Description	Conditions	Min	Typ	Max	Unit
$f_{CLK_EXT_32K}$	external clock frequency	at pin XTAL32KP/P2_0 in GPIO mode	31		33	kHz
$V_{CLK_EXT_32K}$	external clock voltage	at pin XTAL32KP/P2_0 in GPIO mode	1	1.2	1.26	V
f_{XTAL_32K}	crystal oscillator frequency			32.768		kHz
ESR_{32K}	equivalent series resistance				100	k Ω
C_{L_32K}	load capacitance	No external capacitors are required for a 6 pF or 7 pF crystal.	6	7	9	pF
C_{0_32K}	shunt capacitance			1	2	pF
Δf_{XTAL_32K}	crystal frequency tolerance (including aging)	Timing accuracy is dominated by crystal accuracy. A much smaller value is preferred.	-250		250	ppm
$P_{DRV_MAX_32K}$	maximum drive power	(Note 24)	0.1			μW

Note 24: Select a crystal that can handle a drive level of at least this specification.

Table 794: 32 kHz Crystal Oscillator: Timing characteristics

Parameter	Description	Conditions	Min	Typ	Max	Unit
$t_{STA_XTAL_32K}$	crystal oscillator startup time	Typical application, time until 1000 clocks are detected.		400		ms

Table 795: 16 MHz RC Oscillator: AC characteristics

Parameter	Description	Conditions	Min	Typ	Max	Unit
f_{CLK}	clock frequency		6		19	MHz
f_{TOL}	frequency tolerance	after calibration	-93750		93750	ppm

Table 796: 16 MHz RC Oscillator: Timing characteristics

Parameter	Description	Conditions	Min	Typ	Max	Unit
t_{STA}	startup time			5		μs

Table 797: Stable low frequency RCX Oscillator: Timing characteristics

Parameter	Description	Conditions	Min	Typ	Max	Unit
$\Delta f_{\text{RC}}/\Delta T_{\text{RCX}}$	RCX oscillator frequency variation versus temperature	preferred settings applied	-100		100	ppm/deg
$f_{\text{RC_RCX}}$	RCX oscillator frequency	preferred settings applied	8	11.7	15	kHz

Table 798: Low Power PLL: AC characteristics

Parameter	Description	Conditions	Min	Typ	Max	Unit
$f_{\text{O_LPPLL}}$	output frequency			96		MHz

Table 799: Low Power PLL: Timing characteristics

Parameter	Description	Conditions	Min	Typ	Max	Unit
$t_{\text{LOCK_LPPLL_1}}$	frequency settling time	1 % accuracy after VCO calibration			20	μs
$t_{\text{LOCK_LPPLL_2}}$	frequency settling time	200 ppm accuracy		33	100	μs

Table 800: LDO_VBAT: Recommended operating conditions

Parameter	Description	Conditions	Min	Typ	Max	Unit
$I_{\text{L_LDO_VBAT}}$	load current				100	mA
$C_{\text{L_LDO_VBAT}}$	load capacitance		1		100	μF
$\text{ESR}_{\text{CL_LDO_VBAT}}$	equivalent series resistance		0		100	$\text{m}\Omega$

Table 801: LDO_VBAT: DC characteristics

Parameter	Description	Conditions	Min	Typ	Max	Unit
$I_{\text{LK_LDO_VBAT}}$	clamping load current	output short-circuited		160		mA
$V_{\text{LDO_VBAT_START}}$	LDO output voltage	during startup			3.3	V
$V_{\text{LDO_VBAT_0}}$	LDO output voltage	LDO_3V3_LEVEL = 0x0 no load	2.28	2.4	2.52	V
$V_{\text{LDO_VBAT_1}}$	LDO output voltage	LDO_3V3_LEVEL = 0x1 no load	3.13	3.3	3.46	V

Table 801: LDO_VBAT: DC characteristics

Parameter	Description	Conditions	Min	Typ	Max	Unit
V _{LDO_VBAT_2}	LDO output voltage	LDO_3V3_LEVEL = 0x2 no load	3.27	3.45	3.62	V
V _{LDO_VBAT_3}	LDO output voltage	LDO_3V3_LEVEL = 0x3 no load	3.42	3.6	3.78	V
$\frac{\Delta V_O}{\Delta V_{I_LDO_VBAT}}$	line regulation	$V_i \geq (V_o + 200 \text{ mV})$		0.06	0.2	%/V
$\frac{\Delta V_O}{\Delta I_{L_LDO_VBAT}}$	load regulation	10 mA < I _{load} < 100 mA			0.022	%/mA
V _{DROP_VBAT}	dropout voltage	I _L = 1 mA			100	mV
V _{DROP_VBAT_MAX}	maximum dropout voltage	I _L = 110 mA			200	mV

Table 802: LDO_IO: Recommended operating conditions

Parameter	Description	Conditions	Min	Typ	Max	Unit
I _{L_LDO_IO}	load current				75	mA
C _{L_LDO_IO}	load capacitance		1	10	100	μF
ESR _{CL_LDO_IO}	equivalent series resistance		0		100	mΩ

Table 803: LDO_IO: DC characteristics

Parameter	Description	Conditions	Min	Typ	Max	Unit
V _{LDO_IO}	LDO output voltage		1.745	1.8	1.86	V
$\frac{\Delta V_O}{\Delta I_{L_LDO_IO}}$	load regulation	7.5 mA ≤ I _L ≤ 75 mA			0.03	%/mA
$\frac{\Delta V_O}{\Delta V_{I_LDO_IO}}$	line regulation	V _i > (V _o + 0.2V)			0.5	%/V
V _{DROP_IO}	dropout voltage	I _L = 1 mA			100	mV
V _{DROP_IO_MAX}	maximum dropout voltage	I _L = 75 mA			200	mV

Table 804: LDO_VBAT_RET: Recommended operating conditions

Parameter	Description	Conditions	Min	Typ	Max	Unit
I _{L_LDO_VBAT_RET}	load current				3	mA

Table 805: LDO_VBAT_RET: DC characteristics

Parameter	Description	Conditions	Min	Typ	Max	Unit
V _{LDO_VBAT_RET_0}	LDO output voltage	LDO_3V3_LEVEL = 0x0	2.28	2.4	2.52	V
V _{LDO_VBAT_RET_1}	LDO output voltage	LDO_3V3_LEVEL = 0x1	3.13	3.3	3.46	V
V _{LDO_VBAT_RET_2}	LDO output voltage	LDO_3V3_LEVEL = 0x2	3.27	3.45	3.62	V

Table 805: LDO_VBAT_RET: DC characteristics

Parameter	Description	Conditions	Min	Typ	Max	Unit
V _{LDO_VBAT_RET_3}	LDO output voltage	LDO_3V3_LEVEL = 0x3	3.42	3.6	3.78	V
$\Delta V_O / \Delta I_{L_LDO_VBAT_RET}$	load regulation	0.3 mA < I _{load} < 3 mA			0.5	%/mA

Table 806: LDO_IO_RET: Recommended operating conditions

Parameter	Description	Conditions	Min	Typ	Max	Unit
I _{L_LDO_IO_RET}	load current				3	mA

Table 807: LDO_IO_RET: DC characteristics

Parameter	Description	Conditions	Min	Typ	Max	Unit
V _{LDO_VBAT_IO_RET_0}	LDO output voltage	LDO_3V3_LEVEL = 0x0	1.71	1.8	1.89	V
$\Delta V_O / \Delta I_{L_LDO_IO}$	load regulation	0.3 mA < I _{load} < 3 mA			1	%/mA

Table 808: LDO_IO_RET2: DC characteristics

Parameter	Description	Conditions	Min	Typ	Max	Unit
V _{LDO_VBAT_IO_RET_0}	LDO output voltage		1.71	1.8	1.89	V
$\Delta V_O / \Delta I_{L_LDO_IO}$	load regulation	0.3 mA < I _{load} < 3 mA			1	%/mA

Table 809: LDO_USB: Recommended operating conditions

Parameter	Description	Conditions	Min	Typ	Max	Unit
I _{L_LDO_USB}	load current				100	mA
C _{L_LDO_USB}	load capacitance		1		100	μF
ESR _{CL_LDO_USB}	equivalent series resistance		0		100	mΩ

Table 810: LDO_USB: DC characteristics

Parameter	Description	Conditions	Min	Typ	Max	Unit
I _{LK_LDO_USB}	clamping load current	output short-circuited		160		mA
V _{LDO_USB_0}	LDO output voltage	LDO_USB_LEVEL = 0x0	2.28	2.4	2.52	V
V _{LDO_USB_1}	LDO output voltage	LDO_USB_LEVEL = 0x1	3.13	3.3	3.46	V
V _{LDO_USB_2}	LDO output voltage	LDO_USB_LEVEL = 0x2	3.27	3.45	3.62	V
V _{LDO_USB_3}	LDO output voltage	LDO_USB_LEVEL = 0x3	3.42	3.6	3.78	V
$\Delta V_O / \Delta I_{L_LDO_USB}$	load regulation	10 mA ≤ I _L ≤ 100 mA			0.022	%/mA
$\Delta V_O / \Delta V_{I_LDO_USB}$	line regulation	V _i ≥ V _o + 400mV			0.2	%/V

Table 811: SIMO DC-DC converter: Recommended operating conditions

Parameter	Description	Conditions	Min	Typ	Max	Unit
I _{L_1V8}	load current				75	mA
I _{L_1V8P}	load current				75	mA

Table 812: SIMO DC-DC converter: DC characteristics

Parameter	Description	Conditions	Min	Typ	Max	Unit
V _{O_1V8}	output voltage	pin VDD1V8	1.7	1.8	1.9	V
V _{RPL_1V8}	ripple voltage	peak-to-peak value. Using 10 uF, 16 V, X5R capacitors		60	110	mV
V _{ACC_V18}	voltage accuracy	maximum error on average level			6	%
V _{O_1V8P}	output voltage	pin VDD1V8P	1.7	1.8	1.9	V
V _{RPL_1V8P}	ripple voltage	peak-to-peak value. Using 10 uF, 16 V, X5R capacitors		60	110	mV
V _{ACC_1V8P}	voltage accuracy	maximum error on average level			6	%

Table 813: Brownout Detection: DC characteristics

Parameter	Description	Conditions	Min	Typ	Max	Unit
V _{RST_1V2_1}	reset voltage	pin V12; BOD_VDD_LVL = 0x1	0.65	0.7	0.75	V
V _{RST_1V2_3}	reset voltage	pin V12; BOD_VDD_LVL = 0x3	0.75	0.8	0.85	V
V _{RST_1V2_7}	reset voltage	pin V12; BOD_VDD_LVL = 0x7	1.005	1.05	1.095	V
V _{RST_1V8}	reset voltage	pins VDD1V8, VDD1V8P	1.585	1.65	1.715	V
V _{RST_3V3}	reset voltage	pin V33	2.6	2.7	2.8	V
V _{TH_LDO}	threshold voltage below which DC-DC converter is stopped and LDO is active	pin VBAT1	2.35	2.45	2.55	V

Table 814: Charger: DC characteristics

Parameter	Description	Conditions	Min	Typ	Max	Unit
I _{CHARGE_0}	charge current	CHARGER_CTRL1_RE G[CHARGE_CUR] = 0x0 (Note 25)		5	5.75	mA
I _{CHARGE_1}	charge current	CHARGER_CTRL1_RE G[CHARGE_CUR] = 0x1 (Note 25)		10	11.5	mA
I _{CHARGE_2}	charge current	CHARGER_CTRL1_RE G[CHARGE_CUR] = 0x2 (Note 25)	27	30	34.5	mA
I _{CHARGE_3}	charge current	CHARGER_CTRL1_RE G[CHARGE_CUR] = 0x3 (Note 25)	40.5	45	51.75	mA

Table 814: Charger: DC characteristics

Parameter	Description	Conditions	Min	Typ	Max	Unit
I _{CHARGE_4}	charge current	CHARGER_CTRL1_RE G[CHARGE_CUR] = 0x4 (Note 25)	54	60	69	mA
I _{CHARGE_5}	charge current	CHARGER_CTRL1_RE G[CHARGE_CUR] = 0x5 (Note 25)	81	90	103.5	mA
I _{CHARGE_6}	charge current	CHARGER_CTRL1_RE G[CHARGE_CUR] = 0x6 (Note 25)	108	120	138	mA
I _{CHARGE_7}	charge current	CHARGER_CTRL1_RE G[CHARGE_CUR] = 0x7 (Note 25)	135	150	172.5	mA
I _{CHARGE_8}	charge current	CHARGER_CTRL1_RE G[CHARGE_CUR] = 0x8 (Note 25)	162	180	207	mA
I _{CHARGE_9}	charge current	CHARGER_CTRL1_RE G[CHARGE_CUR] = 0x9 (Note 25)	189	210	241.5	mA
I _{CHARGE_10}	charge current	CHARGER_CTRL1_RE G[CHARGE_CUR] = 0xA (Note 25)	243	270	310.5	mA
I _{CHARGE_11}	charge current	CHARGER_CTRL1_RE G[CHARGE_CUR] = 0xB (Note 25)	270	300	345	mA
I _{CHARGE_12}	charge current	CHARGER_CTRL1_RE G[CHARGE_CUR] = 0xC (Note 25)	315	350	402.5	mA
I _{CHARGE_13}	charge current	CHARGER_CTRL1_RE G[CHARGE_CUR] = 0xD (Note 25)	360	400	460	mA
NTCR _{TH_COLD}	NTC to VDD_USB volt- age ratio threshold		83	87.5	92	%
NTCR _{TH_HOT}	NTC to VDD_USB volt- age ratio threshold		45	50	55	%
V _{CHARGE_0}	charge voltage 00000b	CHARGER_CTRL1_RE G[CHARGE_LEVEL] = 0x00	2.91	3	3.09	V
V _{CHARGE_1}	charge voltage 00001b	CHARGER_CTRL1_RE G[CHARGE_LEVEL] = 0x01	3.298	3.4	3.502	V
V _{CHARGE_2}	charge voltage 00010b	CHARGER_CTRL1_RE G[CHARGE_LEVEL] = 0x02	3.395	3.5	3.605	V
V _{CHARGE_3}	charge voltage 00011b	CHARGER_CTRL1_RE G[CHARGE_LEVEL] = 0x03	3.492	3.6	3.708	V
V _{CHARGE_4}	charge voltage 00100b	CHARGER_CTRL1_RE G[CHARGE_LEVEL] = 0x04	3.628	3.74	3.852	V

Table 814: Charger: DC characteristics

Parameter	Description	Conditions	Min	Typ	Max	Unit
V _{CHARGE_5}	charge voltage 00101b	CHARGER_CTRL1_REG[CHARGE_LEVEL] = 0x05	3.744	3.86	3.976	V
V _{CHARGE_6}	charge voltage 00110b	CHARGER_CTRL1_REG[CHARGE_LEVEL] = 0x06	3.88	4	4.12	V
V _{CHARGE_7}	charge voltage 00111b	CHARGER_CTRL1_REG[CHARGE_LEVEL] = 0x07	3.929	4.05	4.172	V
V _{CHARGE_8}	charge voltage 01000b	CHARGER_CTRL1_REG[CHARGE_LEVEL] = 0x08	3.977	4.1	4.223	V
V _{CHARGE_9}	charge voltage 01001b	CHARGER_CTRL1_REG[CHARGE_LEVEL] = 0x09	4.026	4.15	4.275	V
V _{CHARGE_10}	charge voltage 01010b	CHARGER_CTRL1_REG[CHARGE_LEVEL] = 0x0A	4.074	4.2	4.326	V
V _{CHARGE_11}	charge voltage 01011b	CHARGER_CTRL1_REG[CHARGE_LEVEL] = 0x0B	4.123	4.25	4.378	V
V _{CHARGE_12}	charge voltage 01100b	CHARGER_CTRL1_REG[CHARGE_LEVEL] = 0x0C	4.171	4.3	4.429	V
V _{CHARGE_13}	charge voltage 01101b	CHARGER_CTRL1_REG[CHARGE_LEVEL] = 0x0D	4.22	4.35	4.481	V
V _{CHARGE_14}	charge voltage 01110b	CHARGER_CTRL1_REG[CHARGE_LEVEL] = 0x0E	4.268	4.4	4.532	V
V _{CHARGE_15}	charge voltage 01111b	CHARGER_CTRL1_REG[CHARGE_LEVEL] = 0x0F	4.365	4.5	4.635	V
V _{CHARGE_16}	charge voltage 10000b	CHARGER_CTRL1_REG[CHARGE_LEVEL] = 0x10	4.462	4.6	4.738	V
V _{CHARGE_17}	charge voltage 10001b	CHARGER_CTRL1_REG[CHARGE_LEVEL] = 0x11	4.753	4.9	5.047	V
V _{CHARGE_18}	charge voltage 10010b	CHARGER_CTRL1_REG[CHARGE_LEVEL] = 0x12	4.85	5	5.15	V

Note 25: minimum allowed charging temperature is -5 °C.

Table 815: Temperature Sensor: DC characteristics

Parameter	Description	Conditions	Min	Typ	Max	Unit
T _{SENSE}	sense temperature	Measured with on chip ADC	-20		110	°C
T _{SENSE_ACC}	sense temperature accuracy	Single point calibration at 25°C			8.8	°C

Table 816: Fuel Gauge (SOC): DC characteristics

Parameter	Description	Conditions	Min	Typ	Max	Unit
V_{I_FS}	full-scale input voltage				75	mV
SOC_{INL}	state of charge integral non-linearity	$R_{SENSE} = 0.1 \Omega$; $1 \text{ mA} \leq I_{SENSE} \leq 1000 \text{ mA}$		0.05		%

Table 817: General Purpose ADC: Recommended operating conditions

Parameter	Description	Conditions	Min	Typ	Max	Unit
ENOB(AVG16)	Effective Number of Bits	Averaging 16 times; GP_ADC_CTRL_REG=0x4C01; GP_ADC_CTRL2_REG=0x0008; GP_ADC_OFFP_REG=0x0200; GP_ADC_OFFN_REG=0x0200; GP_ADC_DELAY2_REG=0xC000;		10.5		bits
ENOB(AVG32)	Effective Number of Bits	Averaging 32 times; GP_ADC_CTRL_REG=0x4C01; GP_ADC_CTRL2_REG=0x0008; GP_ADC_OFFP_REG=0x0200; GP_ADC_OFFN_REG=0x0200; GP_ADC_DELAY2_REG=0xC000;		10.8		bits
ENOB(AVG64)	Effective Number of Bits	Averaging 64 times; GP_ADC_CTRL_REG=0x4C01; GP_ADC_CTRL2_REG=0x0008; GP_ADC_OFFP_REG=0x0200; GP_ADC_OFFN_REG=0x0200; GP_ADC_DELAY2_REG=0xC000;		11.1		bits

Table 818: General Purpose ADC: DC characteristics

Parameter	Description	Conditions	Min	Typ	Max	Unit
$V_{I(ZS)}$	zero-scale input voltage	single-ended, calibrated at zero input offset calibrated and trimmed bandgap	-6		6	mV
$V_{I(FS)}$	full-scale input voltage	single-ended, calibrated at zero input offset calibrated and trimmed bandgap	1150	1180	1250	mV
$V_{I(FSN)}$	negative full-scale input voltage	differential, calibrated at zero input		-1180		mV

Table 818: General Purpose ADC: DC characteristics

Parameter	Description	Conditions	Min	Typ	Max	Unit
$V_{I(FSP)}$	positive full-scale input voltage	differential, calibrated at zero input		1180		mV
INL	integral non-linearity	GP_ADC_CTRL_REG=0x4C01; GP_ADC_CTRL2_REG=0x0008; GP_ADC_OFFP_REG=0x0200; GP_ADC_OFFN_REG=0x0200; GP_ADC_DELAY2_REG=0xC000;	-2		2	LSB
DNL	differential non-linearity		-2		2	LSB
E_{OFS}	offset error	differential, uncalibrated. GP_ADC_IDYN=1 and GP_ADC_I20U=1	-4		4	LSB
E_G	gain error	GP_ADC_IDYN=1 and GP_ADC_I20U=1	-32		32	LSB

Table 819: General Purpose ADC: Timing characteristics

Parameter	Description	Conditions	Min	Typ	Max	Unit
$t_{CONV(ADC)}$	conversion time	Excluding initial settling time of the LDO and the 3x-attenuation (if used): LDO settling time is 20 μ s (max), 3x-attenuation settling time = 1 μ s (max) Using internal ADC-clock (~200 MHz)		0.25	0.4	μ s

Table 820: LED Driver: DC characteristics

Parameter	Description	Conditions	Min	Typ	Max	Unit
I_{MATCH_LED}	current matching	relative to average LED output current		0.2	2	%
$I_{O_MAX_LED0}$	maximum output current	200 mV saturation voltage and 100% duty cycle	14	19	24	mA
$I_{O_MAX_LED1}$	maximum output current	200 mV saturation voltage and 100% duty cycle	14	19	24	mA
$I_{O_MAX_LED2}$	maximum output current	200 mV saturation voltage and 100% duty cycle	14	19	24	mA
I_{ACC_LED0}	current accuracy	PWM accuracy at 10% duty cycle and above relative to I_{O_MAX} (100% duty cycle)	-2		2	%
I_{ACC_LED1}	current accuracy	PWM accuracy at 10% duty cycle and above relative to I_{O_MAX} (100% duty cycle)	-2		2	%

Table 820: LED Driver: DC characteristics

Parameter	Description	Conditions	Min	Typ	Max	Unit
I _{ACC_LED2}	current accuracy	PWM accuracy at 10% duty cycle and above relative to I _{o_max} (100% duty cycle)	-2		2	%
I _{OFF_LED0}	off-state current	driver disabled			0.2	μA
I _{OFF_LED1}	off-state current	driver disabled			0.2	μA
I _{OFF_LED2}	off-state current	driver disabled			0.2	μA

Table 821: LED Driver: AC characteristics

Parameter	Description	Conditions	Min	Typ	Max	Unit
f _{PWM_LED}	PWM frequency		256		512	Hz

Table 822: USB charger detect: DC characteristics

Parameter	Description	Conditions	Min	Typ	Max	Unit
V _{IH_CHG_DET}	HIGH level input voltage	USB_CHARGER_CTRL_REG[VDP_SRC_ON]=1	0.4			V
V _{IL_CHG_DET}	LOW level input voltage	USB_CHARGER_CTRL_REG[VDP_SRC_ON]=1			0.25	V
V _{IH_DCP_DET}	HIGH level input voltage	USB_CHARGER_CTRL_REG[VDM_SRC_ON]=1	0.8			V
V _{IL_DCP_DET}	LOW level input voltage	USB_CHARGER_CTRL_REG[VDM_SRC_ON]=1			0.25	V
V _{IH_DM_VAL}	HIGH level input voltage		1.5			V
V _{IL_DM_VAL}	LOW level input voltage				0.8	V
V _{IH_DP_VAL}	HIGH level input voltage		1.5			V
V _{IL_DP_VAL}	LOW level input voltage				0.8	V
V _{IH_DM_VAL2}	HIGH level input voltage		2.5			V
V _{IL_DM_VAL2}	LOW level input voltage				2.3	V
V _{IH_DP_VAL2}	HIGH level input voltage		2.5			V
V _{IL_DP_VAL2}	LOW level input voltage				2.3	V
V _{O_DM_SRC}	output voltage		0.5		0.7	V
V _{O_DP_SRC}	output voltage		0.5		0.7	V
I _{DM_SINK}	D- sink current		25		175	μA
I _{DP_SINK}	D+ sink current		25		175	μA
I _{DP_SRC}	D+ source current		5		13	μA
R _{DM_DWN}	D- resistance to ground	USB_CHARGER_CTRL_REG[IDP_SRC_ON] = 1	14.25		24.8	kΩ

Table 823: Digital I/O Pad: DC characteristics

Parameter	Description	Conditions	Min	Typ	Max	Unit
V _{IH}	HIGH level input voltage		0.84			V
V _{IL}	LOW level input voltage				0.36	V
V _{OH_1V8}	HIGH level output voltage	I _O = -4.8 mA, VDD1V8 = 1.80 V	1.44			V
V _{OL_1V8}	LOW level output voltage	I _O = 4.8 mA, VDD1V8 = 1.80 V			0.36	V
V _{OH_3V3}	HIGH level output voltage	I _O = -4.8 mA, V33 = 2.35 V	1.88			V
V _{OL_3V3}	LOW level output voltage	I _O = 4.8 mA, V33 = 2.35 V			0.47	V
I _{IH}	HIGH level input current	V _I = V33 = 3.3 V, excluding USB pads (P11, P22) and P21	-10	5	10	μA
I _{IL}	LOW level input current	V _I = VSS = 0 V, excluding USB pads (P11, P22) and P21	-10	4	10	μA
I _{IH_PD_3V3}	HIGH level input current	V _I = V33 = 3.3 V	65		200	μA
I _{IL_PU_1V8}	LOW level input current	V _I = VSS = 0 V, VDD1V8 = 1.8 V	-110		-35	μA
I _{IL_PU_3V3}	LOW level input current	V _I = VSS = 0 V, V33 = 3.3 V	-200		-65	μA
SR _R	rising slew rate	C _L = 15 pF; I _L = 4.8 mA;	0.4		3.2	V/ns
SR _F	falling slew rate	C _L = 15 pF; I _L = 4.8 mA;	0.4		3.3	V/ns
C _{IN}	input capacitance			0.75		pF

Table 824: Quad SPI Digital I/O Pad: DC characteristics

Parameter	Description	Conditions	Min	Typ	Max	Unit
V _{IH}	HIGH level input voltage	VDDIO = 3.45 V	2.42			V
V _{IL}	LOW level input voltage	VDDIO = 3.45 V			1.04	V
V _{IH_IO_1V8}	HIGH level input voltage	VDDIO = 1.6 V	1.12			V
V _{IL_IO_1V8}	LOW level input voltage	VDDIO = 1.6 V			0.48	V
V _{OH_4mA}	HIGH level output voltage	I _O = 4 mA, VDDIO = 2.8 V	2.24			V
V _{OH_8mA}	HIGH level output voltage	I _O = 8 mA, VDDIO = 2.8 V	2.24			V
V _{OH_12mA}	HIGH level output voltage	I _O = 12 mA, VDDIO = 2.8 V	2.24			V
V _{OH_16mA}	HIGH level output voltage	I _O = 16 mA, VDDIO = 2.8 V	2.24			V
V _{OH_1V6_4mA}	HIGH level output voltage	I _O = 3 mA, VDDIO = 1.65 V	1.32			V
V _{OH_1V6_8mA}	HIGH level output voltage	I _O = 6 mA, VDDIO = 1.65 V	1.32			V
V _{OH_1V6_12mA}	HIGH level output voltage	I _O = 9 mA, VDDIO = 1.65 V	1.32			V

Table 824: Quad SPI Digital I/O Pad: DC characteristics

Parameter	Description	Conditions	Min	Typ	Max	Unit
V _{OH_1V6_16mA}	HIGH level output voltage	I _O = 12 mA, VDDIO = 1.65 V	1.32			V
V _{OH_3V3_100uA}	HIGH level output voltage	I _O = 100 μA, VDDIO = 3.45 V	3.35			V
V _{OL_4mA}	LOW level output voltage	I _O = 4 mA, VDDIO = 2.8 V			0.56	V
V _{OL_8mA}	LOW level output voltage	I _O = 8 mA, VDDIO = 2.8 V			0.56	V
V _{OL_12mA}	LOW level output voltage	I _O = 12 mA, VDDIO = 2.8 V			0.56	V
V _{OL_16mA}	LOW level output voltage	I _O = 16 mA, VDDIO = 2.8 V			0.56	V
V _{OL_1V6_4mA}	LOW level output voltage	I _O = 3 mA, VDDIO = 1.65 V			0.33	V
V _{OL_1V6_8mA}	LOW level output voltage	I _O = 6 mA, VDDIO = 1.65 V			0.33	V
V _{OL_1V6_12mA}	LOW level output voltage	I _O = 9 mA, VDDIO = 1.65 V			0.33	V
V _{OL_1V6_16mA}	LOW level output voltage	I _O = 12 mA, VDDIO = 1.65 V			0.33	V
V _{OL_3V3_100uA}	LOW level output voltage	I _O = 100 μA, VDDIO = 3.45 V			0.1	V
I _{IH}	HIGH level input current	V _I = VDDIO, VDDIO = 3.45 V	-10		10	μA
I _{IH_PD}	HIGH level input current with pull-down	V _I = 1.8 V	25	45	75	μA
I _{IL}	LOW level input current	V _I = VSS, VDDIO = 3.45 V	-10		10	μA
I _{IL_PU}	LOW level input current with pull-up	V _I = VSS, VDDIO = 1.8 V	-75	-45	-25	μA

Table 825: Reset Pad: DC characteristics

Parameter	Description	Conditions	Min	Typ	Max	Unit
V _{IH_RST}	HIGH level input voltage	pin RST	0.84			V
V _{IL_RST}	LOW level input voltage	pin RST			0.36	V
I _{IH_RST}	HIGH level input current	pin RST, V _I = 1.2 V	25		75	μA

Table 826: Radio - BLE mode: Recommended operating conditions

Parameter	Description	Conditions	Min	Typ	Max	Unit
f _{OPER}	operating frequency		2400		2483.5	MHz
N _{CH}	number of channels			40		1
f _{CH}	channel frequency	K = 0 to 39		2402+K*2		MHz

Table 827: Radio - BLE mode: DC characteristics

Parameter	Description	Conditions	Min	Typ	Max	Unit
I _{BAT_RF_RX}	battery supply current	radio receiver and synthesizer active; ideal DC-DC converter; T _A = 25 °C (Note 26)		3.1		mA
I _{BAT_RF_TX}	battery supply current	radio transmitter and synthesizer active; ideal DC-DC converter; T _A = 25 °C (Note 26)		3.4		mA

Note 26: The DC-DC converter efficiency is assumed to be 100 % to enable benchmarking of the radio currents at battery supply domain.

Table 828: Radio - BLE mode: AC characteristics

Parameter	Description	Conditions	Min	Typ	Max	Unit
P _{SENS_CLEAN}	sensitivity level	Dirty Transmitter disabled; DC-DC converter disabled; PER = 30.8 %; (Note 27)		-94		dBm
P _{SENS}	sensitivity level	Normal Operating Conditions; DC-DC converter disabled; PER = 30.8 %; (Note 27)		-93.5		dBm
P _{INT_IMD}	intermodulation distortion interferer power level	worst-case interferer level @ f ₁ , f ₂ with 2*f ₁ - f ₂ = f ₀ , f ₁ - f ₂ = n MHz and n = 3, 4, 5; P _{WANTED} = -64 dBm @ f ₀ ; PER = 30.8 %; (Note 28)	-35	-31		dBm
CIR ₀	carrier to interferer ratio	n = 0; interferer @ f ₁ = f ₀ + n*1 MHz; (Note 29)		7	13	dB
CIR ₁	carrier to interferer ratio	n = ±1; interferer @ f ₁ = f ₀ + n*1 MHz; (Note 29)		-3	2	dB
CIR _{P2}	carrier to interferer ratio	n = +2 (image frequency); interferer @ f ₁ = f ₀ + n*1 MHz; (Note 29)		-20	-12	dB
CIR _{M2}	carrier to interferer ratio	n = -2; interferer @ f ₁ = f ₀ + n*1 MHz; (Note 29)		-30	-26	dB
CIR _{P3}	carrier to interferer ratio	n = +3 (image frequency + 1 MHz); interferer @ f ₁ = f ₀ + n*1 MHz; (Note 29)		-30	-19	dB
CIR _{M3}	carrier to interferer ratio	n = -3; interferer @ f ₁ = f ₀ + n*1 MHz; (Note 29)		-35	-33	dB

Table 828: Radio - BLE mode: AC characteristics

Parameter	Description	Conditions	Min	Typ	Max	Unit
CIR ₄	carrier to interferer ratio	$ n \geq 4$ (any other BLE channel); interferer @ $f_1 = f_0 + n \cdot 1$ MHz; (Note 29)		-37	-33	dB
P _{BL_I}	blocker power level	$30 \text{ MHz} \leq f_{BL} \leq 2000$ MHz; P _{WANTED} = -67 dBm; (Note 30)	-5			dBm
P _{BL_II}	blocker power level (Note 31)	$2003 \text{ MHz} \leq f_{BL} \leq 2399$ MHz; P _{WANTED} = -67 dBm; (Note 30)	-5			dBm
P _{BL_III}	blocker power level	$2484 \text{ MHz} \leq f_{BL} \leq 2997$ MHz; P _{WANTED} = -67 dBm; (Note 30)	-5			dBm
P _{BL_IV}	blocker power level	$3000 \text{ MHz} \leq f_{BL} \leq 12.75$ GHz; P _{WANTED} = -67 dBm; (Note 30)	-5			dBm
P _{RSSI_MIN}	RSSI power level	absolute power level for RXRSSI[7:0] = 0;	-116	-114	-112	dBm
P _{RSSI_MAX}	RSSI power level	upper limit of monotonous range;	-24	-22	-20	dBm
L _{ACC_RSSI}	level accuracy	tolerance at 5 % to 95 % confidence interval of P _{RF} : when RXRSSI[7:0] = X, $50 < X < 175$; burst mode, 1500 packets;		0	2	dB
L _{RES_RSSI}	level resolution	gradient of monotonous range for RXRSSI[7:0] = X, $50 < X < 175$; burst mode, 1500 packets;	0.47	0.48	0.49	dB/LSB
ACP _{2M}	adjacent channel power level	$f_{OFS} \geq 2$ MHz; (Note 32)		-53		dBm
ACP _{3M}	adjacent channel power level	$f_{OFS} \geq 3$ MHz; (Note 32)		-57		dBm
P _O	output power level	maximum gain;	-1	0	1	dBm
P _{O_H2}	output power level (second harmonic)	maximum gain;			-41	dBm
P _{O_H3}	output power level (third harmonic)	maximum gain;			-41	dBm
P _{O_H4}	output power level (fourth harmonic)	maximum gain;			-41	dBm
P _{O_H5}	output power level (fifth harmonic)	maximum gain;			-41	dBm
P _{O_NFM}	output power level (Near Field Mode)	maximum gain; (Note 33)	-25	-20	-15	dBm

Note 27: Measured according to Bluetooth® Low Energy Test Specification RF-PHY.TS/4.0.1, section 6.4.1.

Note 28: Measured according to Bluetooth® Core Technical Specification document, version 4.0, volume 6, section 4.4. Published value is for n = IXIT = 4. IXIT = 5 gives the same results, IXIT = 3 gives results that are 5 dB lower.

Note 29: Measured according to Bluetooth® Core Technical Specification document, version 4.0, volume 6, section 4.2.

Note 30: Measured according to Bluetooth® Core Technical Specification document, version 4.0, volume 6, section 4.3. Due to limitations of the measurement equipment, levels of -5 dBm should be interpreted as > -5 dBm.

Note 31: Frequencies close to the ISM band can show slightly worse performance

Note 32: Measured according to Bluetooth® Low Energy Test Specification RF-PHY.TS/4.0.1, section 6.2.3.

Note 33: To activate the "Near Field Mode", program address 0x50002230, bits 9:5 with the value 0x0. To stop NFC restore previous bitfield value.

39 Package information

39.1 MOISTURE SENSITIVITY LEVEL (MSL)

The MSL is an indicator for the maximum allowable time period (floor life time) in which a moisture sensitive plastic device, once removed from the dry bag, can be exposed to an environment with a maximum temperature of 30 °C and a maximum relative humidity of 60 % RH. before the solder reflow process.

WLCSP packages are qualified for MSL 1.

AQFN packages are qualified for MSL 3.

MSL Level	Floor Life Time
MSL 4	72 hours
MSL 3	168 hours
MSL 2A	4 weeks
MSL 2	1 year
MSL 1	Unlimited at 30 °C / 85 % RH

39.2 WLCSP HANDLING

Manual handling of WLCSP packages should be reduced to the absolute minimum. In cases where it is still necessary, a vacuum pick-up tool should be used. In extreme cases plastic tweezers could be used, but metal tweezers are not acceptable, since contact may easily damage the silicon chip.

Removal will cause damage to the solder balls and therefore a removed sample cannot be reused.

WLCSP is sensitive to visible and infrared light. Precautions should be taken to shield the chip properly in the final product.

39.3 SOLDERING INFORMATION

Refer to the JEDEC standard J-STD-020 for relevant soldering information.

This document can be downloaded from <http://www.jedec.org>.

39.4 PACKAGE OUTLINES

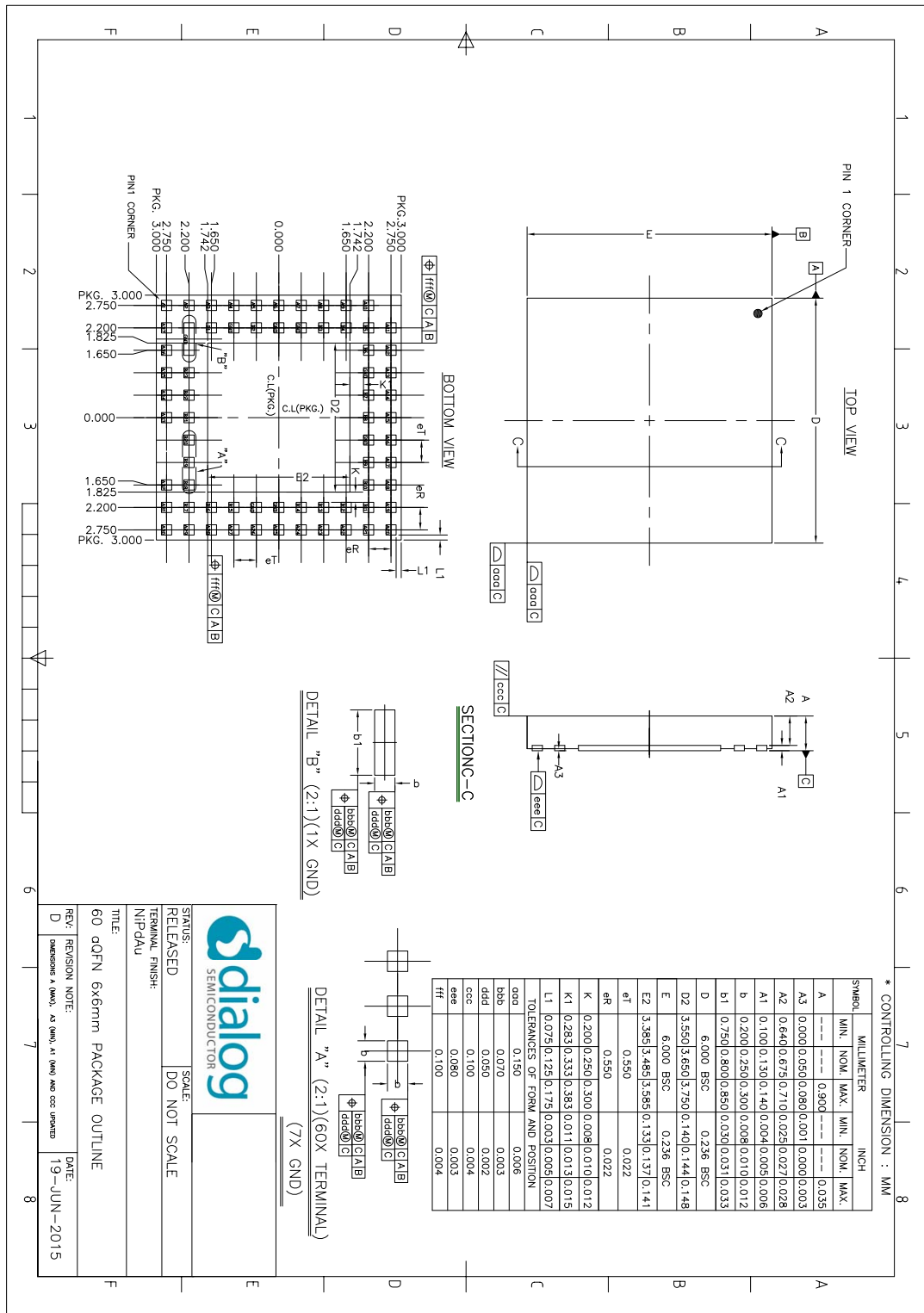

Figure 128: AQFN60 Package Outline Drawing

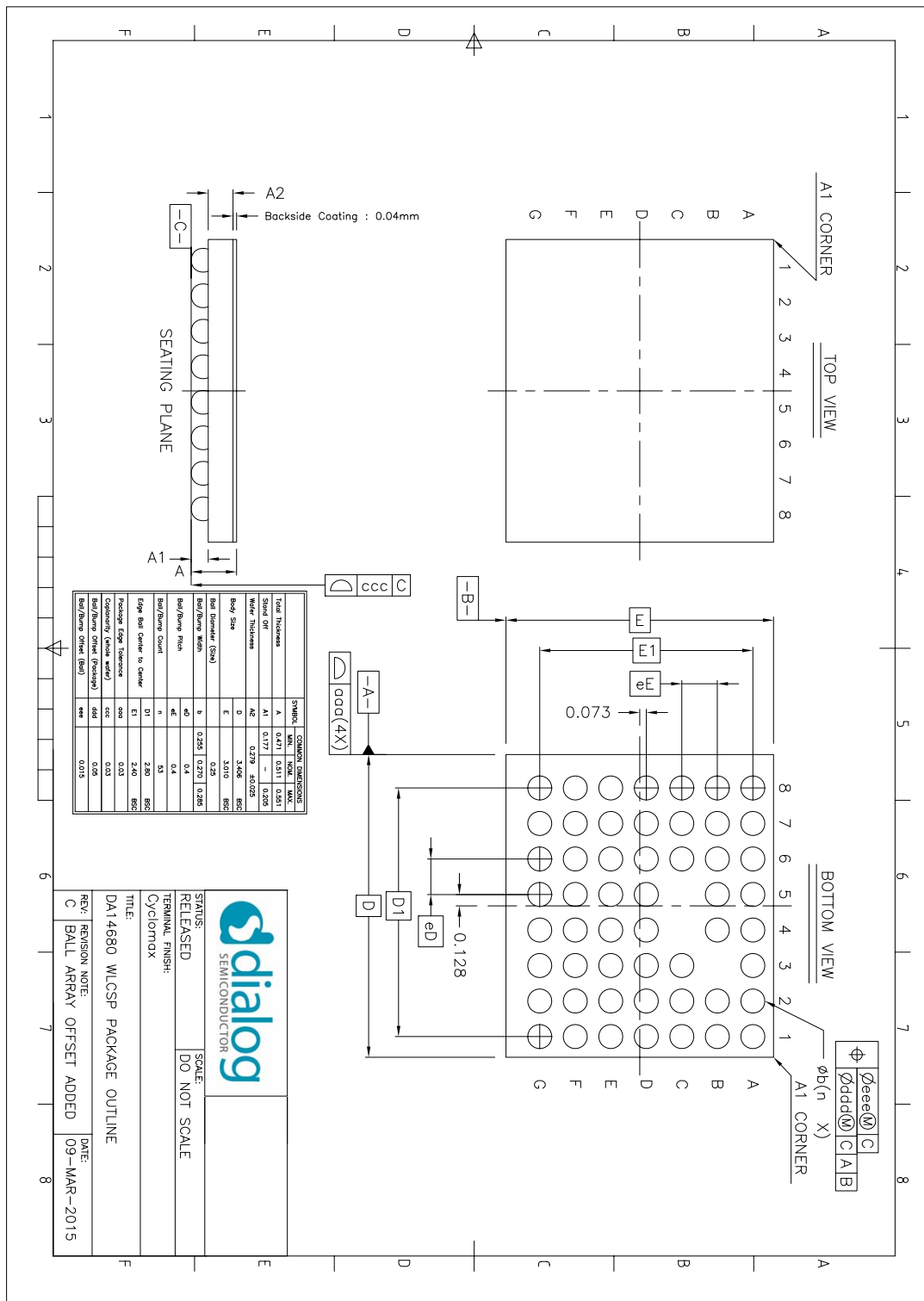

Figure 129: WLCSP53 package outline drawing

Status definitions

Version	Datasheet status	Product status	Definition
1.<n>	Target	Development	This datasheet contains the design specifications for product development. Specifications may change in any manner without notice.
2.<n>	Preliminary	Qualification	This datasheet contains the specifications and preliminary characterisation data for products in pre-production. Specifications may be changed at any time without notice in order to improve the design.
3.<n>	Final	Production	This datasheet contains the final specifications for products in volume production. The specifications may be changed at any time in order to improve the design, manufacturing and supply. Relevant changes will be communicated via Customer Product Notifications.
4.<n>	Obsolete	Archived	This datasheet contains the specifications for discontinued products. The information is provided for reference only.

Disclaimer

Information in this document is believed to be accurate and reliable. However, Dialog Semiconductor does not give any representations or warranties, expressed or implied, as to the accuracy or completeness of such information. Dialog Semiconductor furthermore takes no responsibility whatsoever for the content in this document if provided by any information source outside of Dialog Semiconductor.

Dialog Semiconductor reserves the right to change without notice the information published in this document, including without limitation the specification and design of the related semiconductor products, software and applications.

Applications, software, and semiconductor products described in this document are for illustrative purposes only. Dialog Semiconductor makes no representation or warranty that such applications, software and semiconductor products will be suitable for the specified use without further testing or modification. Unless otherwise agreed in writing, such testing or modification is the sole responsibility of the customer and Dialog Semiconductor excludes all liability in this respect.

Customer notes that nothing in this document may be construed as a license for customer to use the Dialog Semiconductor products, software and applications referred to in this document. Such license must be separately sought by customer with Dialog Semiconductor.

All use of Dialog Semiconductor products, software and applications referred to in this document are subject to Dialog Semiconductor's [Standard Terms and Conditions of Sale](#), unless otherwise stated.

© Dialog Semiconductor. All rights reserved.

RoHS compliance

Dialog Semiconductor complies to European Directive 2001/95/EC and from 2 January 2013 onwards to European Directive 2011/65/EU concerning Restriction of Hazardous Substances (RoHS/RoHS2). Dialog Semiconductor's statement on RoHS can be found on the customer portal <https://support.diasemi.com/>. RoHS certificates from our suppliers are available on request.

Contacting Dialog Semiconductor

United Kingdom (Headquarters)

Dialog Semiconductor (UK) LTD
Phone: +44 1793 757700

Germany

Dialog Semiconductor GmbH
Phone: +49 7021 805-0

The Netherlands

Dialog Semiconductor B.V.
Phone: +31 73 640 8822

Email:

enquiry@diasemi.com

North America

Dialog Semiconductor Inc.
Phone: +1 408 845 8500

Japan

Dialog Semiconductor K. K.
Phone: +81 3 5425 4567

Taiwan

Dialog Semiconductor Taiwan
Phone: +886 281 786 222

Web site:

www.dialog-semiconductor.com

Singapore

Dialog Semiconductor Singapore
Phone: +65 64 8499 29

Hong Kong

Dialog Semiconductor Hong Kong
Phone: +852 3769 5200

Korea

Dialog Semiconductor Korea
Phone: +82 2 3469 8200

China (Shenzhen)

Dialog Semiconductor China
Phone: +86 755 2981 3669

China (Shanghai)

Dialog Semiconductor China
Phone: +86 21 5424 9058

X-ON Electronics

Largest Supplier of Electrical and Electronic Components

Click to view similar products for [RF System on a Chip - SoC category:](#)

Click to view products by [Dialog Semiconductor manufacturer:](#)

Other Similar products are found below :

[BCM20737A1KML2G](#) [BCM43236BKMLG](#) [EM06ELA-512-SGAS](#) [CYBL10463-56LQXI](#) [CYBL10562-56LQXI](#) [CYBL10563-68FLXIT](#)
[ATBTLC1000A-UU-T](#) [EC25AUFA-MINIPCIE](#) [BCM43242KFFBG](#) [BCM20707UA1KFFB1G](#) [ATWILC1000B-UU-T](#) [BCM4322KFBGH](#)
[ETRX3DVK357](#) [88W8801-B0-NMDC/AZ](#) [EC25VFA-MINIPCIE](#) [EC25JFA-MINIPCIE](#) [EC25MXGA-MINIPCIE](#) [EC25AFXGA-MINIPCIE](#)
[EC25AUXGA-MINIPCIE](#) [EC25AUTFA-MINIPCIE](#) [EC25AFFA-MINIPCIE](#) [EP06ALA-512-SGAD](#) [EM06ALA-512-SGAD](#) [EM12GPA-512-](#)
[SGAD](#) [EC25EUGA-MINIPCIE](#) [ESP32-S2FN4R2](#) [TLSR8367EP16](#) [EC25AFA-MINIPCIE](#) [CYBL10463-56LQXIT](#) [CC2511F32RSPR](#) [AX-](#)
[SFEU-API-1-01-TB05](#) [NRF51422-CFAC-R](#) [NRF51822-CDAB-R](#) [XR1015-QH-0G00](#) [NCH-RSL10-101Q48-ABG](#) [AX8052F143-3-TX30](#)
[BLUENRG-232](#) [DA14585-00000AT2](#) [AWR1642ABIGABLQ1](#) [ESP32-D0WD](#) [ESP8266EX](#) [CYBL10561-56LQXI](#) [ATWINC1500B-MU-Y](#)
[ESP32-C3FN4](#) [ESP32-C3](#) [ESP32-D0WDQ6](#) [ESP32-D0WDQ6-V3](#) [ESP32-D0WD-V3](#) [ESP32-PICO-V3](#) [ESP32-PICO-V3-02](#)