

High Power Pump Express™ Plus-Compatible Digital PWM AC/DC Controller

1.0 Features

- Compatible with MediaTek Pump Express™ Plus fast charge protocol
- Universal input off-line controller for applications up to 36W output power
- Low no-load power consumption with optimized system cost (< 30mW at 230V_{AC} for typical 5V2A setting using non synchronous rectifier variants and active start-up device; < 50mW at 230V_{AC} for typical 5V2A setting using non synchronous rectifier variants and resistive start-up; < 75mW at 230V_{AC} for typical 5V2A setting using synchronous rectifier variants and active start-up device)
- **PrimAccurate™** primary-side feedback eliminates opto-isolators and simplifies design
- Adaptive multi-mode PWM/PFM control improves efficiency
- Proprietary optimized 79kHz maximum PWM switching frequency with quasi-resonant operation achieves best size, efficiency and common mode noise
- Active start-up scheme enables fastest possible start-up
- Tight constant-voltage regulation across line and load range
- User-configurable 5-level cable drop compensation provides design flexibility
- **EZ-EMI®** design enhances manufacturability
- No external loop compensation components required
- Built-in single-point fault protections against output short-circuit, output over-voltage, output over-current, auxiliary winding open, and current-sense-resistor-short fault
- Dedicated pin for external over-temperature protection
- Tight constant current control enables output current limit and over-load protection
- Built-in over-temperature protection
- **SmartDefender™** smart hiccup technology helps address issues of soft shorts in cables and connectors by effectively reducing the average output power at fault conditions without latch
- No audible noise over entire operating range



2.0 Description

The iW1788 is a high performance AC/DC power supply controller which uses digital control technology to build peak current mode PWM flyback power supplies and is compatible with MediaTek's Pump Express™ Plus fast charge protocol. With **PrimAccurate** digital primary-side control technology integrated, the iW1788 enables simple, low component count power supplies for universal input off-line applications requiring low BOM cost, high performance solutions. The iW1788 removes the need for secondary feedback circuitry and loop compensation components while achieving excellent stability and line and load regulation.



The Pump Express Plus fast charge protocol enables communication between a smartphone and a wall adapter designed with the iW1788. The high power protocol allows the smartphone to send commands back to the controller to re-configure the output voltage of the adapter from the default 5V output to optimize charge time. The built-in multi-level output IV characteristics allow the designer to minimize the size of the external transformer without sacrificing performance. See section 9.14 for more information on this function.

The iW1788 works with an external power MOSFET to allow for an output power of up to 36W. The device operates in quasi-resonant mode to provide high efficiency and integrates a number of key built-in protection features, such as **EZ-EMI** technology, pulse-by-pulse waveform analysis for faster dynamic load response and a full range of protection features from over-temperature, over-voltage and short-circuit.

Dialog's innovative proprietary technology enables that power supplies designed with the iW1788 can provide configured output voltage 3.6V–4.8V(0.2V/step), 5V, 7V, 9V, 12V with comprehensive built-in output current limit combinations. Furthermore, the chipset can achieve <30mW no-load power consumption at 5V2A output setting and fast dynamic load response in typical or Pump Express+ compliance AC/DC adapter designs.

3.0 Applications

- Compact AC/DC adapterchargers for cell phones, PDAs, digital still cameras
- Fast charge enabled adapters for smartphones
- Universal input AC/DC adapters (5W - 36W)

High Power Pump Express™ Plus-Compatible Digital PWM AC/DC Controller

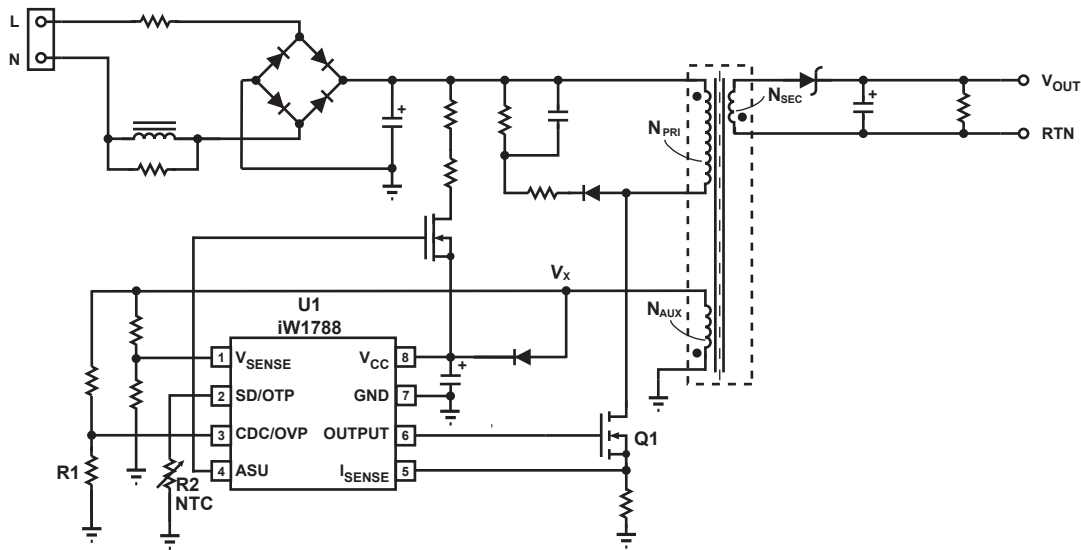

Figure 3.1 : iW1788 Typical Application Circuit for Multi-Level Output Voltage and Current (Using Non SR Variants. Achieving < 30mW No-Load Power Consumption With Active Start-up Device)

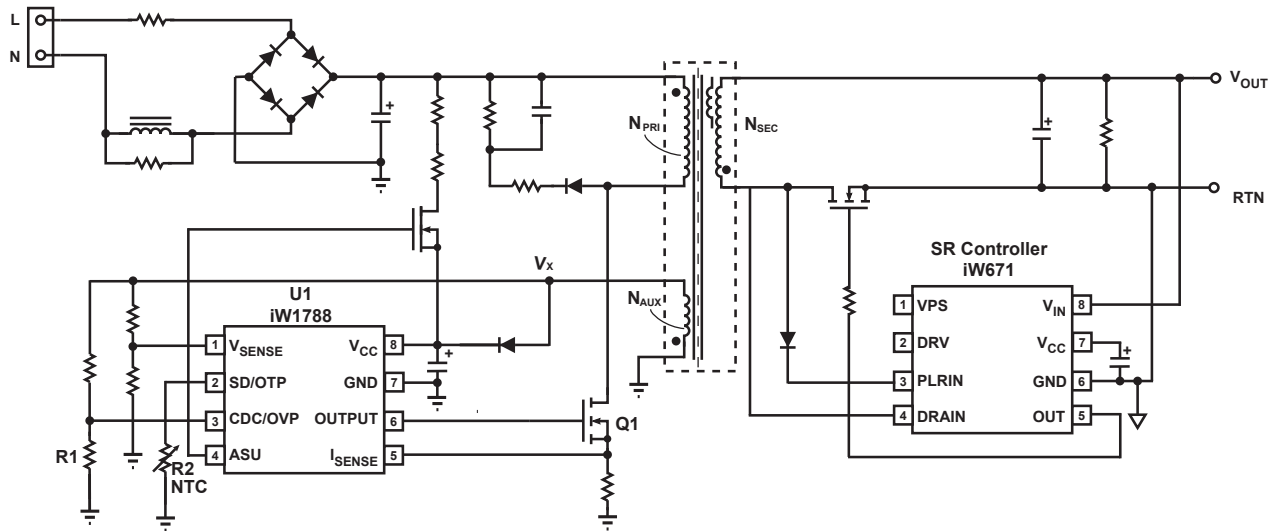

Figure 3.2 : iW1788 Typical Application Circuit for Multi-Level Output Voltage and Current (Using iW671 as Synchronous Rectifier Controller and SR Variants. Achieving < 75mW No-Load Power Consumption With Active Start-up Device)

High Power Pump Express™ Plus-Compatible Digital PWM AC/DC Controller

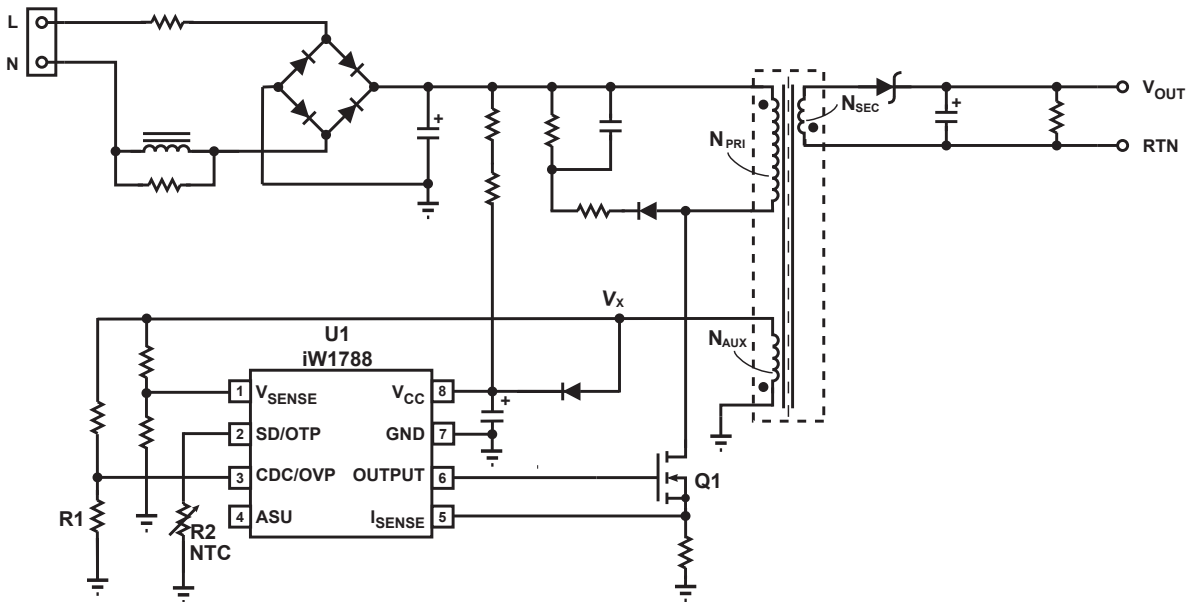

Figure 3.3 : iW1788 Typical Application Circuit for Multi-Level Output Voltage and Current (Using Non SR Variants. Achieving < 50mW No-Load Power Consumption With Resistive Start-up)

High Power Pump Express™ Plus-Compatible Digital PWM AC/DC Controller

4.0 Pinout Description

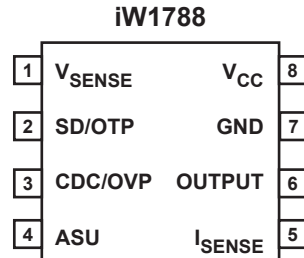

Figure 4.1 : 8-Lead SOIC-8 Package

Pin #	Name	Type	Pin Description
1	V _{SENSE}	Analog Input	Auxiliary voltage sense (used for primary regulation).
2	SD/OTP	Analog Input	External shutdown control. Used for external over-temperature protection (OTP) by connecting an NTC resistor from this pin to Ground.
3	CDC/OVP	Analog Input	Used for external cable drop compensation (CDC) configuration and supplemental over-voltage protection (OVP).
4	ASU	Output	Control signal for active start-up device (BJT or depletion mode NFET).
5	I _{SENSE}	Analog Input	Primary current sense. Used for cycle-by-cycle peak current control and limit.
6	OUTPUT	Output	Gate drive for external MOSFET switch.
7	GND	Ground	Ground.
8	V _{CC}	Power Input	Power supply for control logic.

High Power Pump Express™ Plus-Compatible Digital PWM AC/DC Controller

5.0 Absolute Maximum Ratings

Absolute maximum ratings are the parameter values or ranges which can cause permanent damage if exceeded.

Parameter	Symbol	Value	Units
DC supply voltage range (pin 8, $I_{CC} = 20\text{mA max}$)	V_{CC}	-0.3 to 25.0	V
Continuous DC supply current at V_{CC} pin ($V_{CC} = 15\text{V}$)	I_{CC}	20	mA
ASU output (pin 4)		-0.3 to 19.0	V
OUTPUT (pin 6)		-0.3 to 20.0	V
V_{SENSE} input (pin 1, $I_{Vsense} \leq 10\text{mA}$)		-0.7 to 4.0	V
I_{SENSE} input (pin 5)		-0.3 to 4.0	V
SD/OTP (pin 2)		-0.3 to 4.0	V
CDC/OVP (pin 3, $I_{CFG} \leq 20\text{mA}$)		-0.8 to 4.0	V
Maximum junction temperature	T_{JMAX}	150	°C
Operating junction temperature	T_{JOPT}	-40 to 150	°C
Storage temperature	T_{STG}	-65 to 150	°C
Thermal resistance junction-to-ambient	θ_{JA}	160	°C/W
ESD rating per JEDEC JESD22-A114		$\pm 2,000$	V
Latch-up test per JESD78A		± 100	mA

High Power Pump Express™ Plus-Compatible Digital PWM AC/DC Controller

6.0 Physical Dimensions

8-Lead Small Outline (SOIC) Package

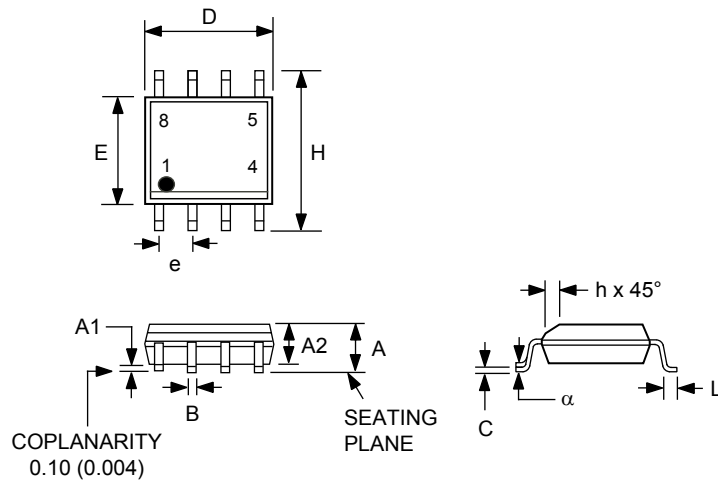

Symbol	Inches		Millimeters	
	MIN	MAX	MIN	MAX
A	0.053	0.069	1.35	1.75
A1	0.0040	0.010	0.10	0.25
A2	0.049	0.059	1.25	1.50
B	0.014	0.019	0.35	0.49
C	0.007	0.010	0.19	0.25
D	0.189	0.197	4.80	5.00
E	0.150	0.157	3.80	4.00
e	0.050 BSC		1.27 BSC	
H	0.228	0.244	5.80	6.20
h	0.10	0.020	0.25	0.50
L	0.016	0.049	0.4	1.25
α	0°	8°		

Compliant to JEDEC Standard MS12F

Controlling dimensions are in inches; millimeter dimensions are for reference only

This product is RoHS compliant and Halide free.

Soldering Temperature Resistance:

[a] Package is IPC/JEDEC Std 020D moisture sensitivity level 1

[b] Package exceeds JEDEC Std No. 22-A111 for solder immersion resistance; package can withstand 10 s immersion < 260°C

Dimension D does not include mold flash, protrusions or gate burrs. Mold flash, protrusions or gate burrs shall not exceed 0.15 mm per end. Dimension E1 does not include interlead flash or protrusion. Interlead flash or protrusion shall not exceed 0.25 mm per side.

The package top may be smaller than the package bottom. Dimensions D and E1 are determined at the outermost extremes of the plastic body exclusive of mold flash, tie bar burrs, gate burrs and interlead flash, but including any mismatch between the top and bottom of the plastic body.

High Power Pump Express™ Plus-Compatible Digital PWM AC/DC Controller

7.0 Ordering Information

Part Number	Options		Package	Description
	Power Level (W)	Max Output Voltage (V)		
iW1788-17	15W	12V	SOIC-8	Tape & Reel ¹
iW1788-26-B1	15W	12V	SOIC-8	Tape & Reel ¹
iW1788-29	15W	9V	SOIC-8	Tape & Reel ¹
iW1788-46	24W	12V	SOIC-8	Tape & Reel ¹
iW1788-51	20W	12V	SOIC-8	Tape & Reel ¹
iW1788-78	14W	7V	SOIC-8	Tape & Reel ¹
iW1788-95	15W	12V	SOIC-8	Tape & Reel ¹
iW1788-96	33W	12V	SOIC-8	Tape & Reel ¹
iW1788-98	24W	12V	SOIC-8	Tape & Reel ¹

Note 1: Tape & Reel packing quantity is 2,500/reel. Minimum ordering quantity is 2,500.

High Power Pump Express™ Plus-Compatible Digital PWM AC/DC Controller

Disclaimer

Information in this document is believed to be accurate and reliable. However, Dialog Semiconductor does not give any representations or warranties, expressed or implied, as to the accuracy or completeness of such information. Dialog Semiconductor furthermore takes no responsibility whatsoever for the content in this document if provided by any information source outside of Dialog Semiconductor.

Dialog Semiconductor reserves the right to change without notice the information published in this document, including without limitation the specification and the design of the related semiconductor products, software and applications.

Applications, software, and semiconductor products described in this document are for illustrative purposes only. Dialog Semiconductor makes no representation or warranty that such applications, software and semiconductor products will be suitable for the specified use without further testing or modification. Unless otherwise agreed in writing, such testing or modification is the sole responsibility of the customer and Dialog Semiconductor excludes all liability in this respect.

Customer notes that nothing in this document may be construed as a license for customer to use the Dialog Semiconductor products, software and applications referred to in this document. Such license must be separately sought by customer with Dialog Semiconductor.

All use of Dialog Semiconductor products, software and applications referred to in this document are subject to Dialog Semiconductor's [Standard Terms and Conditions of Sale](#), unless otherwise stated.

Pump Express and Pump ExpressPlus are trademarks of MediaTek Inc.

© Dialog Semiconductor (UK) Ltd. All rights reserved.

RoHS compliance

Dialog Semiconductor complies to European Directive 2001/95/EC and from 2 January 2013 onwards to European Directive 2011/65/EU concerning Restriction of Hazardous Substances (RoHS/RoHS2).

Dialog Semiconductor's statement on RoHS can be found on the customer portal <https://support.diasemi.com/>. RoHS certificates from our suppliers are available on request.

Contacting Dialog Semiconductor

United Kingdom

Dialog Semiconductor (UK) Ltd
Phone: +44 1793 757700

Germany

Dialog Semiconductor GmbH
Phone: +49 7021 805-0

The Netherlands

Dialog Semiconductor B.V.
Phone: +31 73 640 88 22

Email

info_pcbg@diasemi.com

North America

Dialog Semiconductor Inc.
Phone: +1 408 845 8500

Japan

Dialog Semiconductor K. K.
Phone: +81 3 5425 4567

Taiwan

Dialog Semiconductor Taiwan
Phone: +886 281 786 222

Web site:

www.dialog-semiconductor.com

Singapore

Dialog Semiconductor Singapore
Phone: +65 648 499 29

Hong Kong

Dialog Semiconductor Hong Kong
Phone: +852 2607 4271

Korea

Dialog Semiconductor Korea
Phone: +82 2 3469 8200

China

*Dialog Semiconductor
(Shenzhen)*
Phone: +86 755 2981 3669

*Dialog Semiconductor
(Shanghai)*
Phone: +86 21 5424 9058

X-ON Electronics

Largest Supplier of Electrical and Electronic Components

Click to view similar products for [Switching Controllers](#) category:

Click to view products by [Dialog Semiconductor](#) manufacturer:

Other Similar products are found below :

[LV5065VB-TLM-H](#) [LV5066V-TLM-H](#) [LV5725JAZ-AH](#) [633888R](#) [MP2908AGF](#) [AZ7500EP-E1](#) [NCP1012AP133G](#) [NCP1217P133G](#)
[NCP1218AD65R2G](#) [NCP1234AD100R2G](#) [NCP1244BD065R2G](#) [NCP1336ADR2G](#) [NCP1587GDR2G](#) [NCP6153MNTWG](#)
[NCP81005MNTWG](#) [NCP81101BMNTXG](#) [NCP81205MNTXG](#) [HV9123NG-G-M934](#) [IR35207MTRPBF](#) [ISL6367HIRZ](#) [CAT874-80ULGT3](#)
[SJ6522AG](#) [SJE6600](#) [TLE63893GV50XUMA1](#) [IR35215MTRPBF](#) [SG3845DM](#) [NCP1216P133G](#) [NCP1236DD65R2G](#) [NCP1247BD100R2G](#)
[NCP1250BP65G](#) [NCP4202MNR2G](#) [NCP4204MNTXG](#) [NCP6132AMNR2G](#) [NCP81141MNTXG](#) [NCP81142MNTXG](#) [NCP81172MNTXG](#)
[NCP81203MNTXG](#) [NCP81206MNTXG](#) [NX2155HCUPTR](#) [UC3845ADM](#) [UBA2051C](#) [IR35201MTRPBF](#) [MAX8778ETJ+](#)
[MAX17500AAUB+T](#) [MAX17411GTM+T](#) [MAX16933ATIR/V+](#) [NCP1010AP130G](#) [NCP1063AD100R2G](#) [NCP1216AP133G](#)
[NCP1217AP100G](#)