

Single-Stage LED Driver with PFC Supports Wide Range of Dimming Interfaces

1 Description

The iW3636 is a high-performance, single-stage AC/DC power controller for PWM dimmable LED driver with power factor (PF) correction. It supports most commonly used isolated and non-isolated flyback and buck-boost topologies. The device operates in constant on-time mode to achieve high power factor (> 0.9) across a wide load range. It uses Dialog's **PrimAccurate™** advanced primary-side sensing technology to achieve excellent output current regulation over line and load variation without the need for secondary feedback components. It also eliminates the need for external loop compensation while maintaining stability over all operating conditions.

The iW3636 offers a 1% to 100% dimming range and provides a dedicated PWM dimming input pin that supports a wide variety of dimming application interfaces such as wireless modules, MCUs or 0-10V interfaces. When working with Dialog's secondary-side SSL PWM signal generator IC, the iW339, the iW3636 adopts a proprietary technique to support accurate dimming by eliminating the impact from the non-ideal characteristics of optocouplers. In addition, the iW3636 accepts a secondary PWM or analog input to allow maximum output current configuration control.

Dialog's innovative proprietary technology maximizes the iW3636 performance in an SOIC-8 package. It provides two multi-function pins to configure IC functions such as the dimming curve and minimum dimming level. The iW3636 also enables the active start-up scheme to achieve the shortest possible start-up time without sacrificing active efficiency. By adaptively controlling the maximum operating frequency at different dimming levels, it helps eliminate audible noise and achieve low standby power consumption.

2 Features

- Universal AC input ($90V_{AC}$ - $305V_{AC}$) or DC input voltage
- Enhanced MOSFET driver supports up to 90W output power in an SOIC-8 package
- Primary-side control achieves very tight line and load regulation ($\pm 3\%$)
- $PF > 0.9$ and $THD < 20\%$ across wide output power range
- Dual dimming interfaces
- Supports fully isolated 0-10V dimming with Dialog's iW339 interface controller
- Low standby power
- Wide dimming range 1% - 100%
- Configurable 72kHz or 90kHz PWM switching frequency with quasi-resonant operation
- Configurable minimum dimming setting: dim-to-off, 1%, 5% or 10%
- Wide V_{CC} operating range from 7.5V to 30V
- Built-in over-temperature protection or by external NTC
- Configurable dimming curve: linear or logarithmic
- Built-in soft-start achieves fast and smooth start-up for all different operating conditions
- Active start-up scheme enables fastest possible start-up
- Built-in single-point fault protection features: output open, output over-voltage, output short and input voltage under-voltage protections
- Light-off mode with soft-off feature and configurable voltage regulation value

3 Applications

- Intelligent and wireless LED lighting
- Dimming LED ballast

Single-Stage LED Driver with PFC
Supports Wide Range of Dimming Interfaces

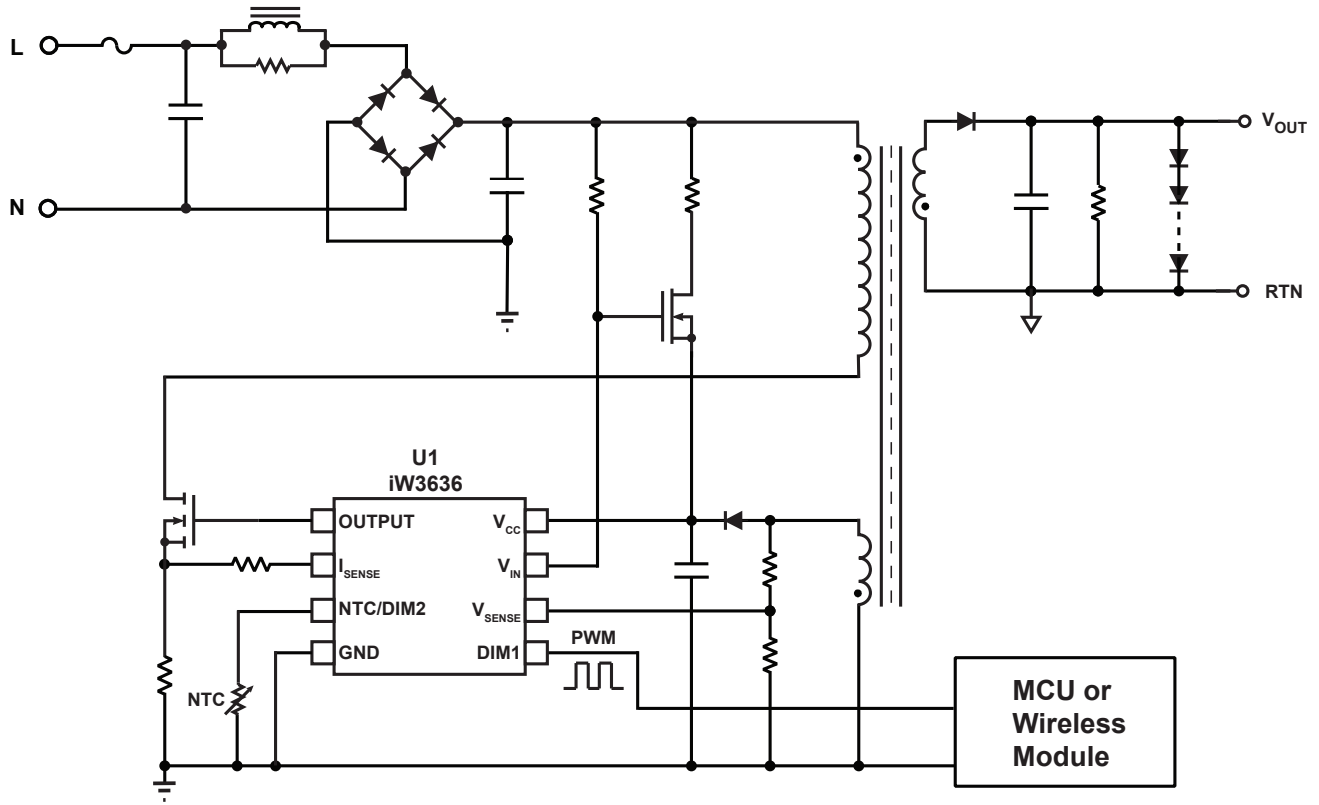

Figure 3.1 : iW3636 Typical Application Circuit (Wireless Dimming with NTC Derating Using Depletion-mode FET as Active Start-up Device).

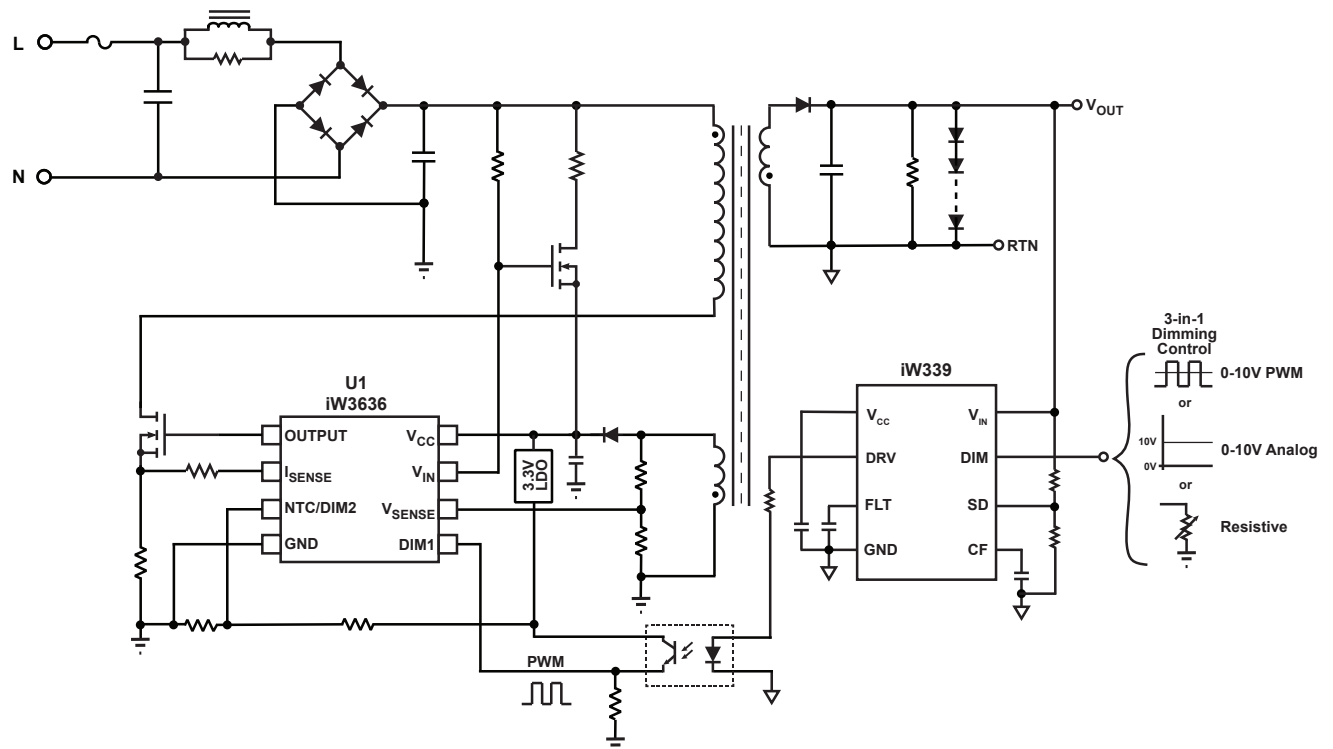

Figure 3.2 : iW3636 Typical Application Circuit (3-in-1 Dimming with Maximum Current Modulated by the Voltage at NTC/ DIM2 Pin and Using Enhancement-mode FET as Active Start-up Device).

Single-Stage LED Driver with PFC Supports Wide Range of Dimming Interfaces

4 Pinout Description

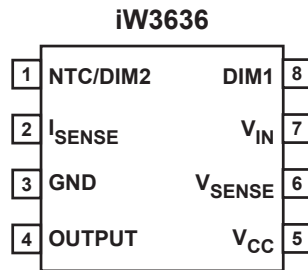

Figure 4.1 : 8-Lead SOIC-8 Package

Pin Number	Pin Name	Type	Pin Description
1	NTC/DIM2	Digital Input / Analog In/Out	Used for external temperature sensing via an NTC resistor, or to provide a 2nd dimming interface via PWM signal or analog signal (0 – 1.8V).
2	I _{SENSE}	Analog Input	Provides primary current sense for cycle-by-cycle peak current control and limit during normal operation, and serves as a configuration pin during startup.
3	GND	Ground	Ground.
4	OUTPUT	Output	Gate drive for external MOSFET switch.
5	V _{CC}	Power	IC power supply.
6	V _{SENSE}	Analog Input	Provides output voltage sense for primary regulation during normal operation, and serves as a configuration pin during startup.
7	V _{IN}	Analog Input	Dual function. Used to control active start-up devices and sense line voltage.
8	DIM1	Digital Input	PWM dimming input detection.

Single-Stage LED Driver with PFC Supports Wide Range of Dimming Interfaces

5 Absolute Maximum Ratings

Absolute maximum ratings are the parameter values or ranges which can cause permanent damage if exceeded.

Parameter	Symbol	Value	Units
DC supply voltage range (pin 5, $I_{CC} = 10\text{mA max}$)	V_{CC}	-0.3 to 31	V
Continuous DC supply current at V_{CC} pin	I_{CC}	20	mA
V_{IN} (pin 7)		-0.3 to 31	V
Output (pin 4)		-0.3 to 31	V
V_{SENSE} input (pin 6, $I_{VSENSE} \leq 10\text{mA}$)		-0.3 to 7	V
I_{SENSE} input (pin 2)		-0.3 to 7	V
NTC/DIM2 (pin 1)		-0.3 to 7	V
DIM1 (pin 8)		-0.3 to 7	V
Maximum junction temperature	T_{JMAX}	150	°C
Operating junction temperature	T_{JOPT}	-40 to 150	°C
Storage temperature	T_{STG}	-65 to 150	°C
Thermal resistance junction-to-ambient	θ_{JA}	170	°C/W
ESD rating per JEDEC JS-001-2017		$\pm 2,000$	V
Latch-up test per JESD78E		± 100	mA

**Single-Stage LED Driver with PFC
Supports Wide Range of Dimming Interfaces**

6 Physical Dimensions

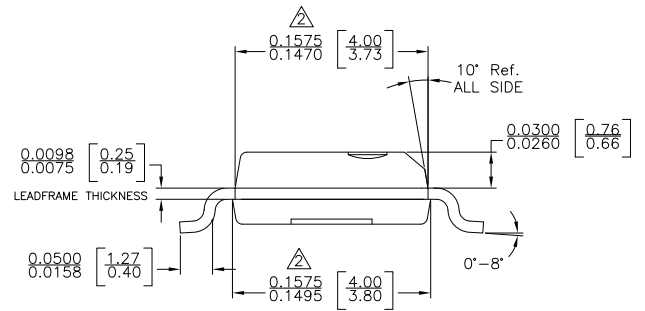
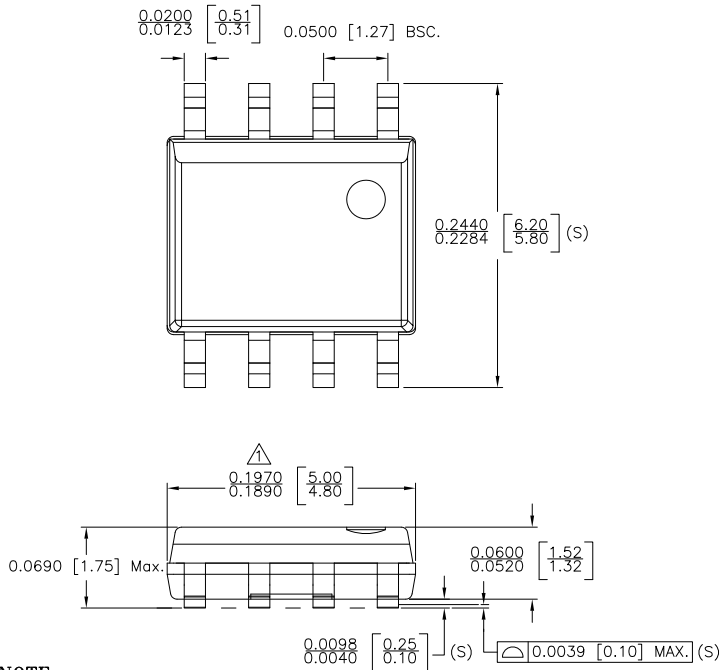

NOTE :

- 1. DOES NOT INCLUDE MOLD FLASH, PROTRUSIONS OR GATE BURRS. MOLD FLASH, PROTRUSIONS AND GATE BURRS SHALL NOT EXCEED .006 INCH PER SIDE.
- 2. DOES NOT INCLUDE INTER-LEAD FLASH OR PROTRUSIONS. INTER-LEAD FLASH AND PROTRUSIONS SHALL NOT EXCEED .010 INCH PER SIDE.
- 3. THIS PART IS COMPLIANT WITH JEDEC SPECIFICATION MS-012.
- 4. LEAD SPAN/STAND OFF HEIGHT/COPLANARITY ARE CONSIDERED AS SPECIAL CHARACTERISTIC(S)
- 5. CONTROLLING DIMENSIONS IN INCHES. [mm]

STATUS: RELEASED	SCALE: DO NOT SCALE
TERMINAL FINISH: 100% Sn or NiPdAu (PPF)	
TITLE: 8 SOIC PACKAGE OUTLINE	
REV: A	DATE: 02-MAR-2015

7 Ordering Information

Part no.	Options	Package	Description
iW3636-01	PWM DIM2 interface	SOIC-8	Tape & Reel ¹
iW3636-02	NTC DIM2 interface	SOIC-8	Tape & Reel ¹
iW3636-03	Analog DIM2 interface	SOIC-8	Tape & Reel ¹
iW3636-31	Analog DIM2 interface (Internal OTP Disabled)	SOIC-8	Tape & Reel ¹

Note 1: Tape and reel packing quantity is 2,500/reel. Minimum packing quantity is 2,500.

Single-Stage LED Driver with PFC Supports Wide Range of Dimming Interfaces

Disclaimer

Information in this document is believed to be accurate and reliable. However, Dialog Semiconductor does not give any representations or warranties, expressed or implied, as to the accuracy or completeness of such information. Dialog Semiconductor furthermore takes no responsibility whatsoever for the content in this document if provided by any information source outside of Dialog Semiconductor.

Dialog Semiconductor reserves the right to change without notice the information published in this document, including without limitation the specification and the design of the related semiconductor products, software and applications.

Applications, software, and semiconductor products described in this document are for illustrative purposes only. Dialog Semiconductor makes no representation or warranty that such applications, software and semiconductor products will be suitable for the specified use without further testing or modification. Unless otherwise agreed in writing, such testing or modification is the sole responsibility of the customer and Dialog Semiconductor excludes all liability in this respect.

Customer notes that nothing in this document may be construed as a license for customer to use the Dialog Semiconductor products, software and applications referred to in this document. Such license must be separately sought by customer with Dialog Semiconductor.

All use of Dialog Semiconductor products, software and applications referred to in this document are subject to [Dialog Semiconductor's Standard Terms and Conditions of Sale](#), available on the company website (www.dialog-semiconductor.com) unless otherwise stated.

Dialog and the Dialog logo are trademarks of Dialog Semiconductor plc or its subsidiaries. All other product or service names are the property of their respective owners.

© 2019 Dialog Semiconductor. All rights reserved.

RoHS Compliance

Dialog Semiconductor's suppliers certify that its products are in compliance with the requirements of Directive 2011/65/EU of the European Parliament on the restriction of the use of certain hazardous substances in electrical and electronic equipment. RoHS certificates from our suppliers are available on request.

Contacting Dialog Semiconductor

United Kingdom (Headquarters)
Dialog Semiconductor (UK) LTD
Phone: +44 1793 757700

Germany
Dialog Semiconductor GmbH
Phone: +49 7021 805-0

The Netherlands
Dialog Semiconductor B.V.
Phone: +31 73 640 8822

Email
info_pcbg@diasemi.com

North America
Dialog Semiconductor Inc.
Phone: +1 408 845 8500

Japan
Dialog Semiconductor K. K.
Phone: +81 3 5769 5100

Taiwan
Dialog Semiconductor Taiwan
Phone: +886 281 786 222

Web site:
www.dialog-semiconductor.com

Hong Kong
Dialog Semiconductor Hong Kong
Phone: +852 2607 4271

Korea
Dialog Semiconductor Korea
Phone: +82 2 3469 8200

China (Shenzhen)
Dialog Semiconductor China
Phone: +86 755 2981 3669

China (Shanghai)
Dialog Semiconductor China
Phone: +86 21 5424 9058

X-ON Electronics

Largest Supplier of Electrical and Electronic Components

Click to view similar products for [LED Display Drivers](#) category:

Click to view products by [Dialog Semiconductor](#) manufacturer:

Other Similar products are found below :

[MAP9000QNRH](#) [AP5726WUG-7](#) [AL8806QMP-13](#) [AP5726FDCG-7](#) [AS3693B-ZTQT](#) [AP5725WUG-7](#) [MAX139EQH+D](#) [STP16DP05PTR](#)
[STP16CPP05PTR](#) [STP16CPP05XTTR](#) [LV5236VZ-TLM-H](#) [BP9911CC](#) [ZXLD1366QEN8TC](#) [MT7725D](#) [TX6143](#) [SY6813PEC](#) [SD1002L4](#)
[AW3643CSR](#) [MP3370GN-Z](#) [LA2284L-G09-T](#) [SEDA](#) [SCT2027CSSG](#) [LYT3315D](#) [LYT3324D](#) [LYT4211E2](#) [LYT4214E2](#) [LYT4215E2](#)
[LYT4217E2](#) [LYT4218E2](#) [LYT4222E](#) [LYT4317E2](#) [LYT4321E](#) [LYT4323E](#) [LYT4324E3](#) [LYT4326E3](#) [TPS92020DR](#) [TPS92691PWPR](#)
[BCR420U](#) [HV9801ALG-G](#) [IS31FL3199-QFLS2-TR](#) [IS31FL3731-QFLS2-TR](#) [CAT4238TD](#) [SCT2001ASIG](#) [SCT2024CSTG](#) [SCT2167CSOG](#)
[SCT2167CSSG](#) [STP16CPPS05XTTR](#) [TLE4241GMFUMA1](#) [ICM7212MIQH+D](#) [ICM7212AIQH+D](#)